

SIEMENS

Ingenuity for life

SINAMICS G Safety Integrated for entry level personnel

Technical overview

[siemens.com/drives](https://www.siemens.com/drives)

1. Risks relating to plants, systems and machines

2. Drives with "Safety Integrated" in the application

3. "Safety Integrated" – an overview of the functions

4. Minimizing risks in plants, systems and machines

5. Additional information on "Safety Integrated"

Legal information

Warning information concept

This manual contains information that you must observe in order to ensure your own personal safety as well as to avoid material damage. Information referring to your personal safety is highlighted by a warning triangle; information that only relates to material damage has no warning triangle. Depending on the hazard level, warning notices are indicated in descending order as follows.

 HAZARD
indicates that death or severe personal injury will result if proper precautions are not taken.

 WARNING
indicates that death or severe personal injury can result if the appropriate precautions are not taken.

 CAUTION
indicates that minor injury can result if the appropriate precautions are not taken.

 NOTICE
indicates that property damage can result if proper precautions are not taken.

If more than one level of danger simultaneously applies, then the warning notice for the highest level is used. A warning note in a warning triangle indicating possible personal injury may also include a warning note relating to material damage.

Qualified Personnel

The product/system described in this documentation may be operated only by **personnel qualified** for the specific task in accordance with the relevant documentation, in particular its warning notices and safety instructions. Qualified personnel are those who, based on their training and experience, are capable of identifying risks and avoiding potential hazards when working with these products/systems.

Intended use of Siemens products

Note the following:

 WARNING
Siemens products may only be used for the applications listed in the catalog and the associated technical documentation. If third-party products and components are used, then they must be recommended or approved by Siemens. These products can only function correctly and safely if they are transported, stored, set up, mounted, installed, commissioned, operated and maintained correctly. The permissible environmental conditions must be complied with. Information and instructions in the associated documentation must be observed.

Trademarks

All names identified by the trademark symbol ® are registered trademarks of Siemens AG. Other designations used in this document may be trademarks whose use by third parties for their own purposes could violate the rights of the trademark owners.

Disclaimer of liability

We have checked that the contents of this document correspond to the hardware and software described. However, since deviations cannot be completely excluded, we do not accept any guarantee for full compliance. The information given in this publication is reviewed at regular intervals; any corrections that may be necessary are made in subsequent editions.

Table of contents

1	Risks relating to plants, systems and machines	4
2	Drives with “Safety Integrated” in the application	5
2.1	Preventing starting	5
2.2	Safely stopping	8
2.3	Safely limiting velocity or speed	13
2.3.1	Chuck protection on a lathe.....	13
2.3.2	Paper logistics in a printing machine.....	17
2.3.3	Commissioning the „Safely-Limited Speed (SLS)” function with Startdrive.....	19
2.4	Safely turning in a specific direction	21
2.4.1	Gate drive.....	21
2.4.2	Cleaning printing rolls.....	23
2.4.3	Commissioning the „Safe Direction (SDI)” function using Startdrive	24
3	An overview of the “Safety Integrated” functions	26
4	Minimizing risks in plants, systems and machines	28
5	Additional information on “Safety Integrated”	30

Risks relating to plants, systems and machines

1

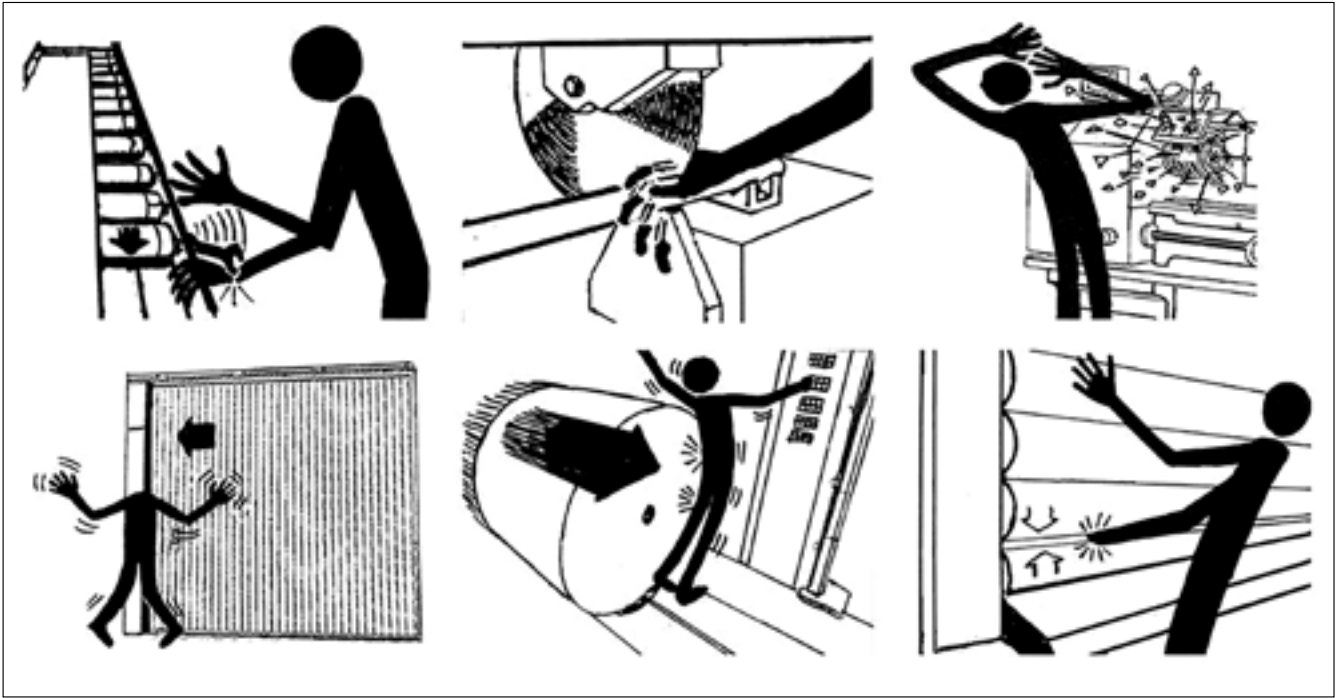

When one of your job functions involves building plants, systems and machines, you are perhaps aware of these or similar risks and dangers for personnel that operate and/or maintain machines.

What does „Safety Integrated“ have to do with these risks?

“Safety Integrated” means that the sensors, controls, switchgear and drives installed in or on the machine already have certain functions that are tailored to address typical hazards and risks in a machine.

Generally, moving machine parts and components represent the root cause of hazards, which is why special emphasis is given to electric drives in this description.

The risks in machines are just as varied and diverse as the machines themselves. This is the reason that this description demonstrates the use of drives with “Safety Integrated” based on examples:

- What does a typical application in a plant, system or machine look like?
- What is the hazard in this specific application?
- How can the machine be made safer?
- What does a classic solution with converter and external wiring look like?
- In a direct comparison, what does a solution with a drive and „Safety Integrated“ look like?
- How difficult is it to commission „Safety Integrated“?

The focus is on relatively basic machines or basic applications in more complicated machines – applications that can often be realized without a programmable control system (PLC).

Further, we restrict ourselves to applications with a standard induction motor and without an encoder to sense the speed.

After some application examples for “Safety Integrated”, we discuss general procedures to analyze risks in plants and systems or machines.

And finally, we will show how to access other brochures and more in-depth information on the topic of “Safety integrated”.

With this description, it is our intention to give you a better understanding of what drives with “Safety Integrated” can do and how they are used. Perhaps the examples will also inspire you as a machine builder to discover new applications for drives with “Safety Integrated”.

Drives with „Safety Integrated“ in the application

2

Hazards in production machines are subsequently described using examples. The measures to resolve these hazards are subdivided into four typical categories:

- Preventing starting (Page 5)
- Safely stopping (Page 8)
- Safely limiting velocity or speed (Page 13)
- Safely turning in a specific direction (Page 21)

The examples do not go into the finest technical detail. To keep the descriptions concise and understandable, the solutions only describe the most important signals for controlling the converter and the principle employed when commissioning. You always require the technical product documentation to completely select, dimension, install and commission a drive.

2.1 Preventing starting

Preventing a drive from starting means that the energy feed to the drive must be immediately and safely shut down.

Carrying out repair work on a roller conveyor

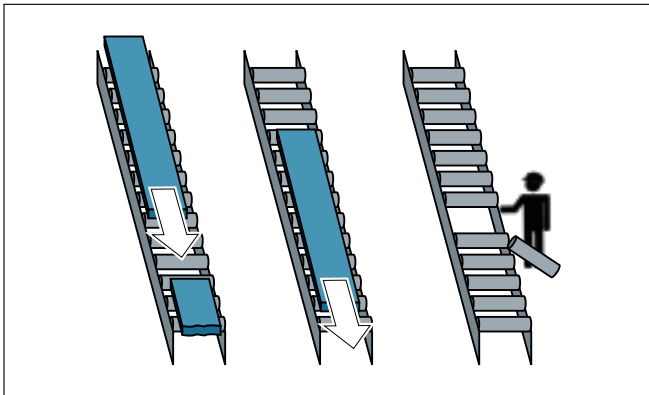

Within a plant or system, roller conveyors transport material from one processing station to another.

In the course of maintenance and/or repair work, mechanical components of a roller conveyor are replaced.

HAZARD

Risk of injury when a roller conveyor drive starts while repairs are being carried out.



Risk minimization:

While carrying out repairs, roller conveyors must not start.



Classic solution using an external circuit

A safety relay evaluates the signals of an Emergency Stop pushbutton and opens the two line contactors K1 and K2.

The drive is electrically disconnected from the line supply and can no longer start.

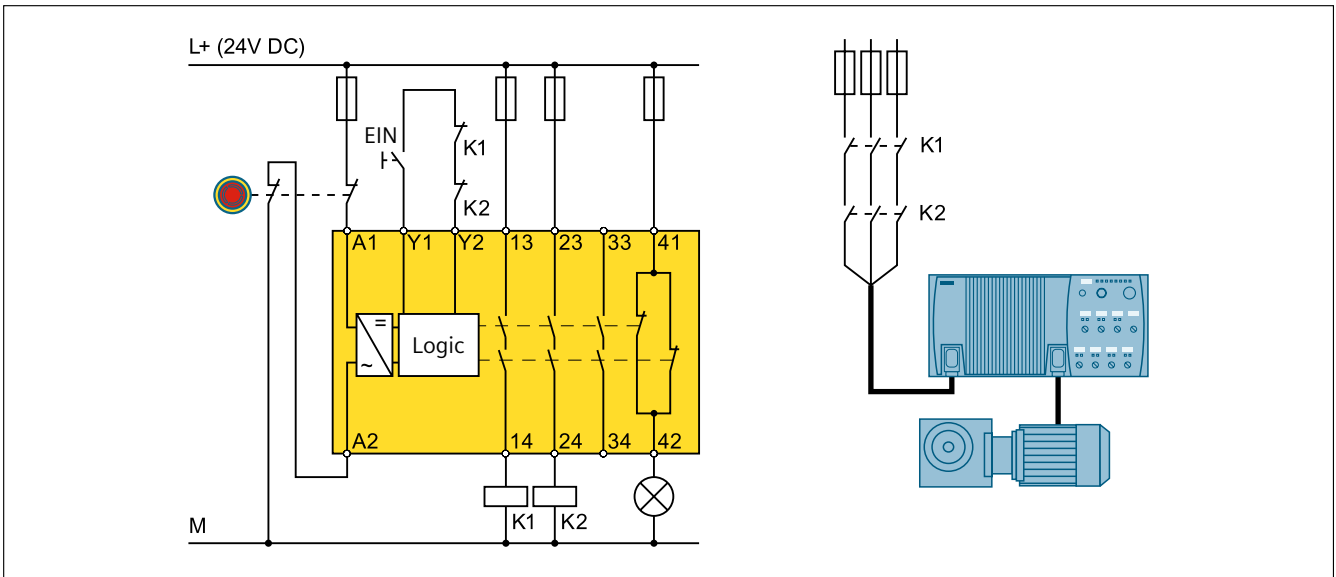

Figure 2-1 Preventing starting using an external circuit

Solution with "Safety Integrated"

For this application, the converter already has the „Safe Torque Off“ function – a certified „Safety Integrated“ function. The converter directly evaluates the signal from

the Emergency Stop button. When the Emergency Stop button is pressed, the „Safe Torque Off“ function prevents the conveyor from starting.

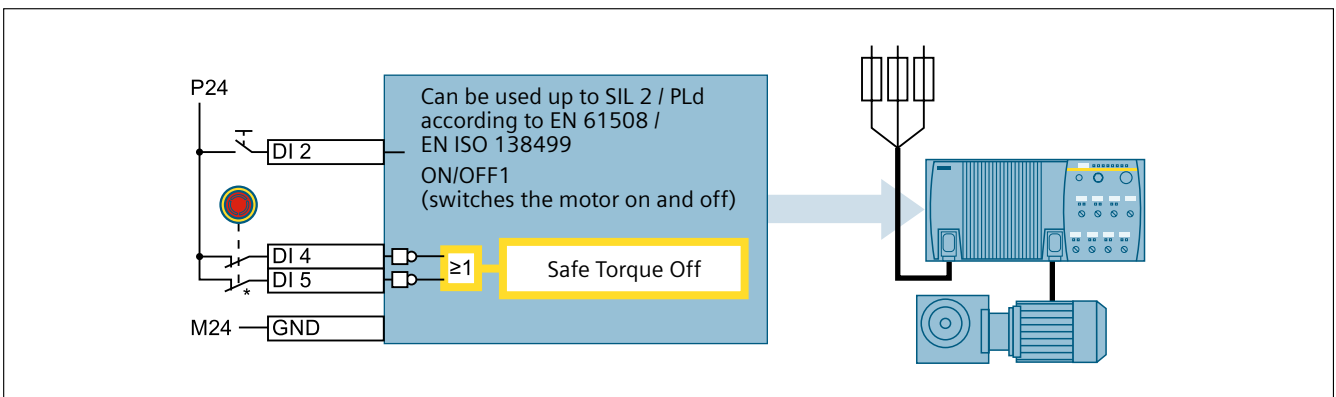

Figure 2-2 Preventing starting using "Safety Integrated"

*Short-circuit free routing according to EN ISO 13849-2 is required.

The „Safe Torque Off“ function prevents a motor from starting just as reliably and safely as classic electrical isolation. However, with the „Safety Integrated“ solution, the

converter remains connected to the line supply while in the Emergency Stop condition and is immediately ready for use after the Emergency Stop pushbutton has been released.

Commissioning the „Safe Torque Off (STO)“ function using Startdrive

The converter is commissioned using Startdrive – a commissioning tool embedded in the TIA Portal for SIEMENS drives. Using Startdrive, you adapt the converter functions to address your specific application using graphic screen forms.

The „Safe Torque Off“ function (STO) is commissioned with just a few mouse clicks.



Figure 2-3 Commissioning the „Safe Torque Off“ (STO) function using Startdrive

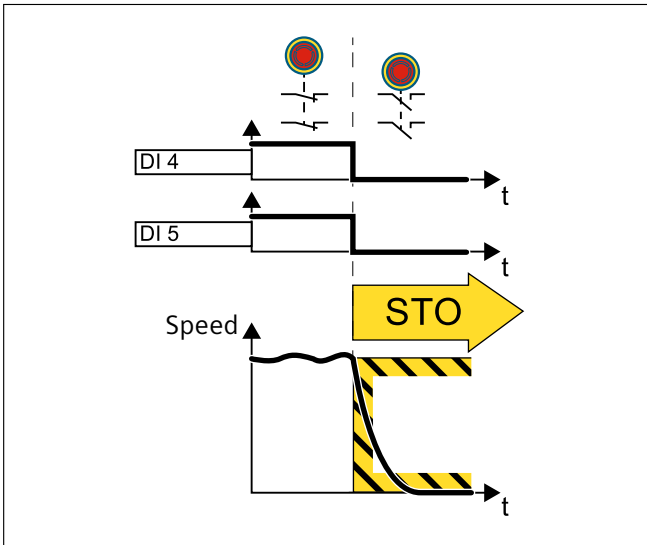

If you select „Basic functions via onboard terminals“ in Start-drive, you enable the STO function in the converter. The converter automatically assigns the two digital inputs DI 4 and DI 5 to the STO function.

A „Low“ signal state at both inputs activates the STO function.

2.2 Safely stopping

Safely stopping means that initially a motor brakes down to a standstill. What happens at standstill depends on the specific application. For reasons of simplicity, we only consider applications here that allow the energy feed to the motor to be switched off at standstill, i.e. to prevent the motor from restarting.

Troubleshooting a saw

In the following example, a saw cuts material to specified lengths. A guard fence secures the system. It may be necessary that somebody enters the system if the saw system develops a fault.

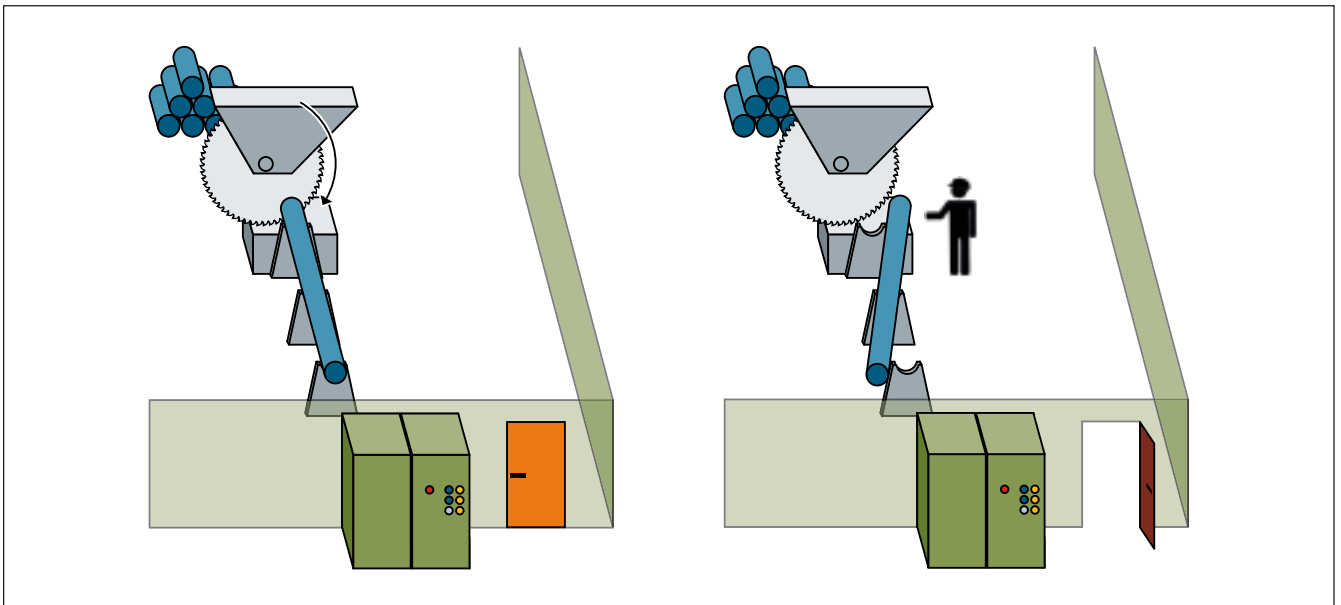

HAZARD

Risk of injury caused by the saw blade that coasts down after the motor has been switched off.

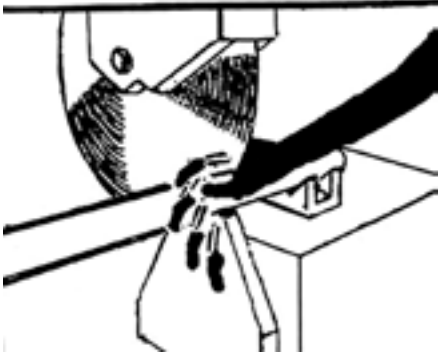

Risk minimization:

The saw must have come to a complete standstill before somebody enters the hazardous area.

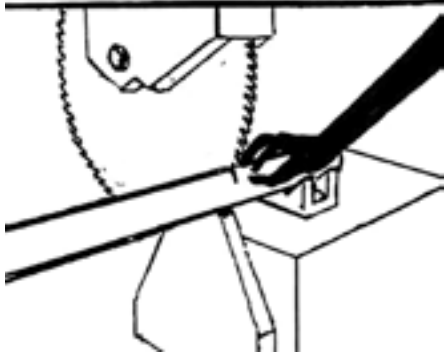

Classic solution using an external circuit

A safety relay evaluates the Emergency Stop command. After the Emergency Stop pushbutton has been actuated, the drive receives a command to stop the motor as quickly as possible (OFF3).

The safety relay disconnects the converter from the line supply with a certain delay.

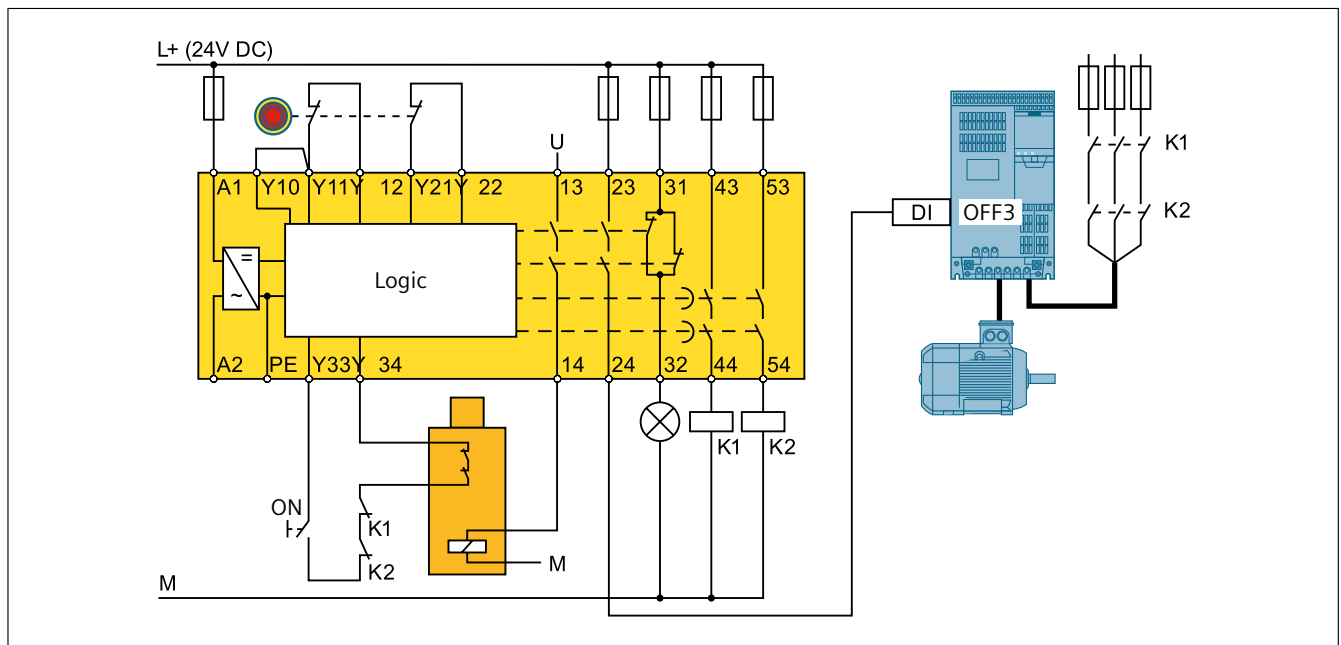
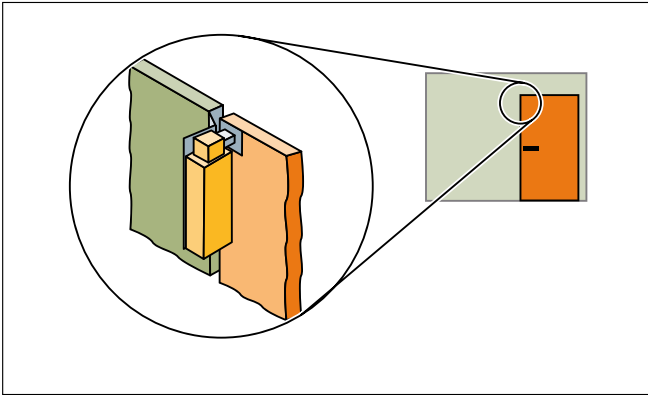

Figure 2-4 Safely stopping – classic solution using an external circuit



In normal operation, the protective door in the guard fence must remain interlocked. It is only permissible that the door is released if there is no longer any risk of injury in the saw system.

For safety-related protective doors such as these, position switches with electromagnetic tumbler (interlocking) mechanism have established themselves.

The safety relay not only switches the drive on and off, but must also evaluate the position switches of the protective door. The drive can only be switched on when the protective door is closed. The protective door is interlocked when the drive is switched on.

Solution with "Safety Integrated"

The same functionality, but with significantly less installation costs, can also be implemented using a converter and a certified „Safety Integrated“ function. The Emergency Stop pushbutton signal is directly wired to the converter terminals.

The Emergency Stop command initiates the „Safe Stop 1“ function in the converter. The converter brakes, the saw blade down to a non-hazardous speed and then releases the protective door via one of its outputs.

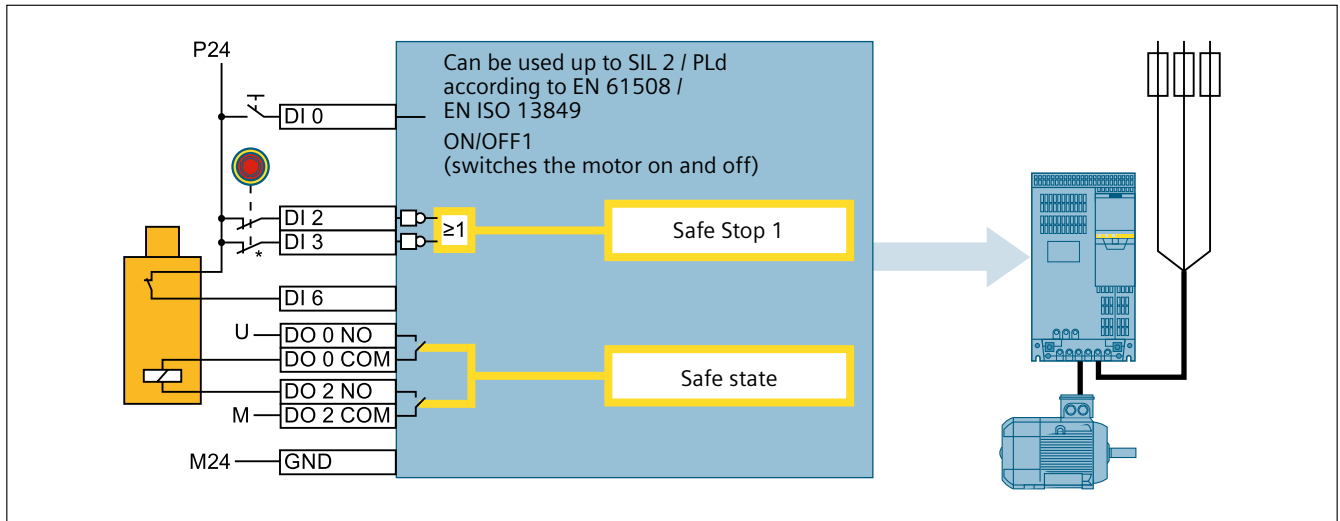

Figure 2-5 Stopping safely – solution with „Safety Integrated“

*Short-circuit free routing according to EN ISO 13849-2 is required.

When compared to a classic solution with external circuitry, the converter always remains connected to the line supply. This means that it is immediately ready for operation once the Emergency Stop pushbutton has been released. Further, the converter continually monitors the motor

speed – which also means while it is stopped. In the case of a fault, if the motor does not brake in the appropriate time, then the converter signals this and the protective door remains interlocked.

Commissioning the „Safe Stop 1 (SS1)“ function with Startdrive

Using Startdrive, you enable the „Safety Integrated“ function „Safe Stop 1“ and assign this function to a safety-related input that you select.

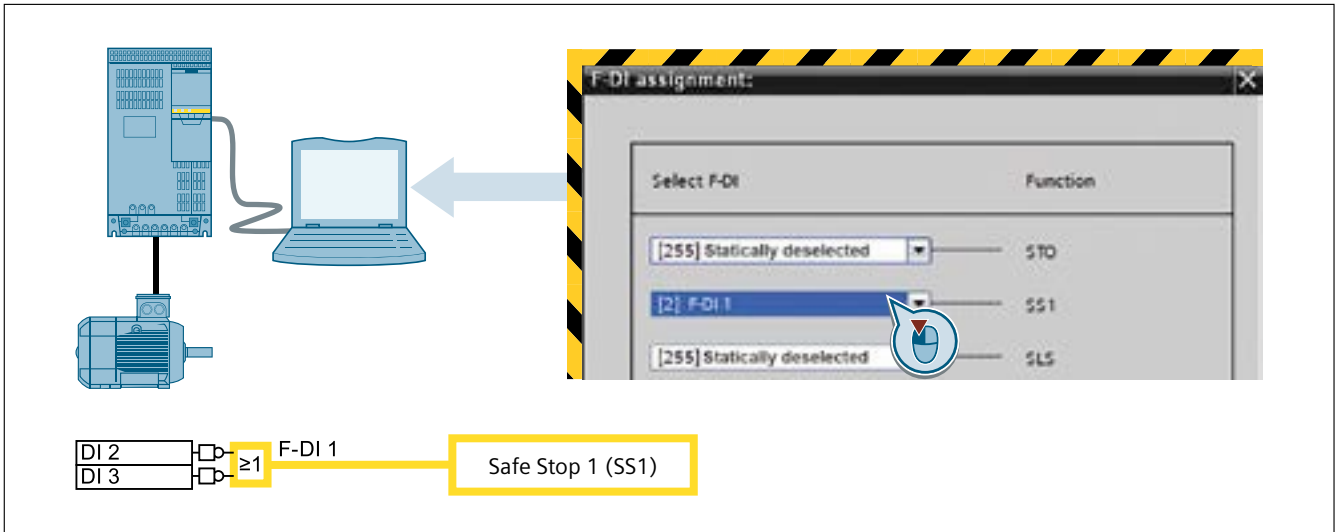

Figure 2-6 Assigning the safe input to the "Safe Stop 1" (SS1) function

The converter monitors the motor while it brakes. You must set this monitoring by adapting the „Safe Brake Ramp monitoring“ to the drive braking ramp.

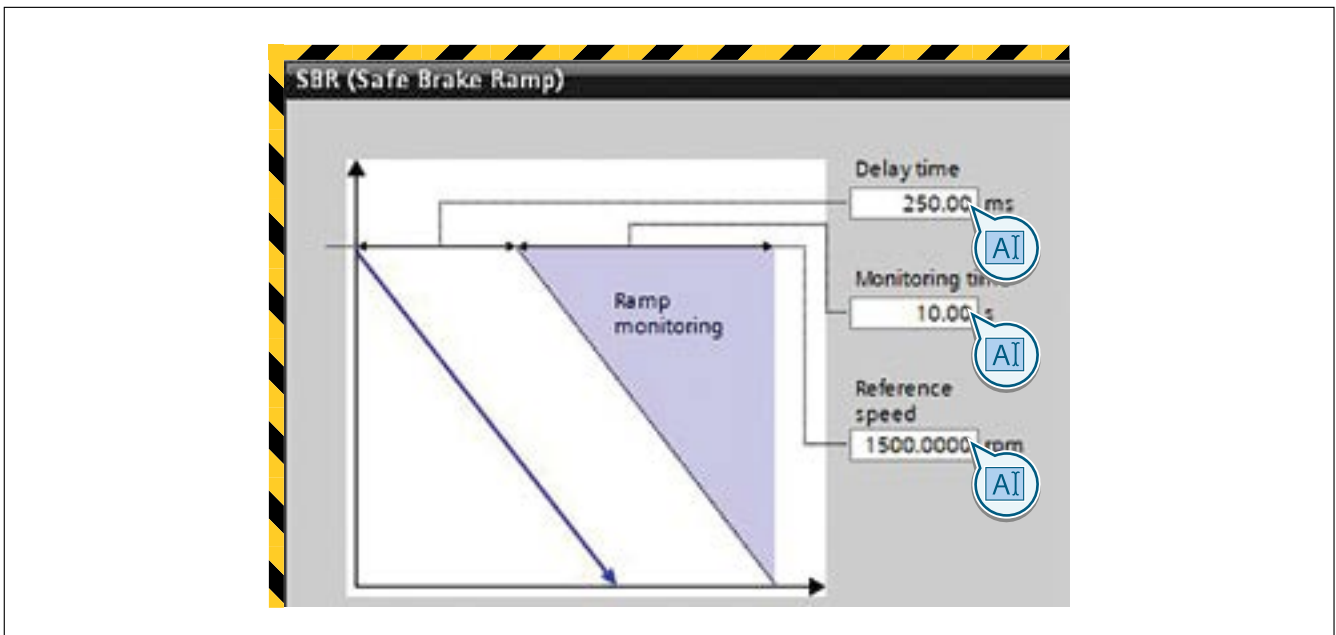
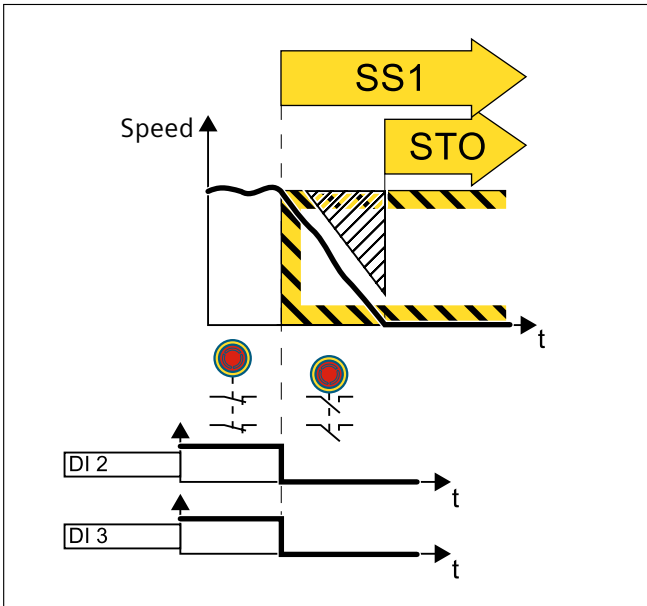

Figure 2-7 Adapting the monitoring of function SS1 to the braking ramp



A „Low“ signal state at both of the assigned terminals activates the SS1 function.

The converter brakes the motor and monitors to ensure that the speed decreases as expected.

As soon as the speed is low enough, the converter switches off the motor and using function „STO“, prevents the motor from restarting.

You still require a signal that releases the protective door.

A converter with a safety-related output supplies the signal directly to the position switch (with interlocking mechanism) at the protective door.

It is only permissible that the protective door opens once all of the conditions have been satisfied:

- Function SS1 is selected → „SS1 active“ = 1
- The motor has braked → „STO is active“ = 1
- When braking, the speed monitoring function in the converter had not identified any fault → „Internal event“ = 1

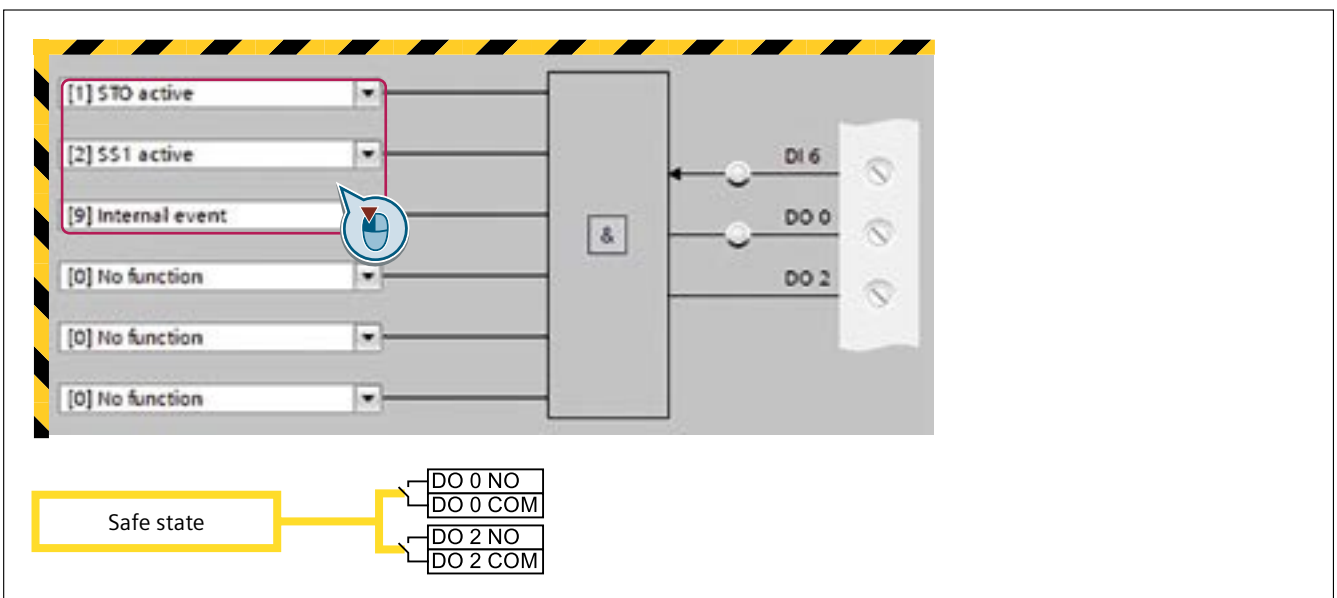

Figure 2-8 Generating a signal to release the protective door

If you are using a converter that is not equipped with a safety-related output, then you must generate the signal to release the protective door in the higher-level control system. In this case, you require a safety-related control system and a PROFIsafe connection to the converter.

2.3 Safely limiting velocity or speed

Whether it involves feeding material into a machine in the setting-up mode or servicing machine parts – it may be necessary for persons to intervene in an operational plant, system or machine. In situations such as these, frequently it is only possible to manage the risk of injury if the speed/velocity of the machine components involved is reduced.

2.3.1 Chuck protection on a lathe

Lathes used to machine metal using a converter as spindle drive with chuck allow maintenance-free variable-speed operation. Contrary to induction motors that are directly connected to the line supply, converters allow the speed range to be extended up to a multiple of the line frequency.

On the other hand, this means that an incorrect setting, e.g. as a result of converter manipulation, can result in high machine speeds.

The task of the machine builder is to utilize the additional functions that a converter drive offers without having to tolerate any increased risks.

HAZARD

Injury because centrifugal forces when operating at an excessively high speed actuate the chuck element, releasing the workpiece.



Risk minimization:

The machine independently monitors and limits the speed of the spindle on which the chuck is mounted.

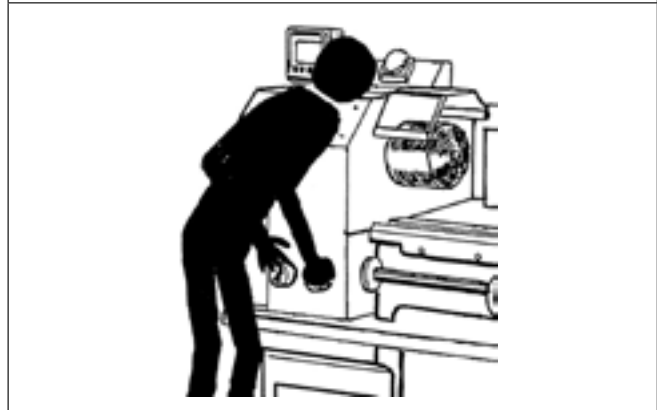

Classic solution using an external circuit

A safety-related speed monitor evaluates the signals from the encoder and shaft breakage detection of the motor. The output signals of the speed monitor are wired to a safety relay.

For an excessively high motor speed (and when the Emergency Stop pushbutton has been actuated), the converter receives the OFF3 command to stop the motor as quickly as possible. The safety relay disconnects the converter from the line supply with a certain delay.

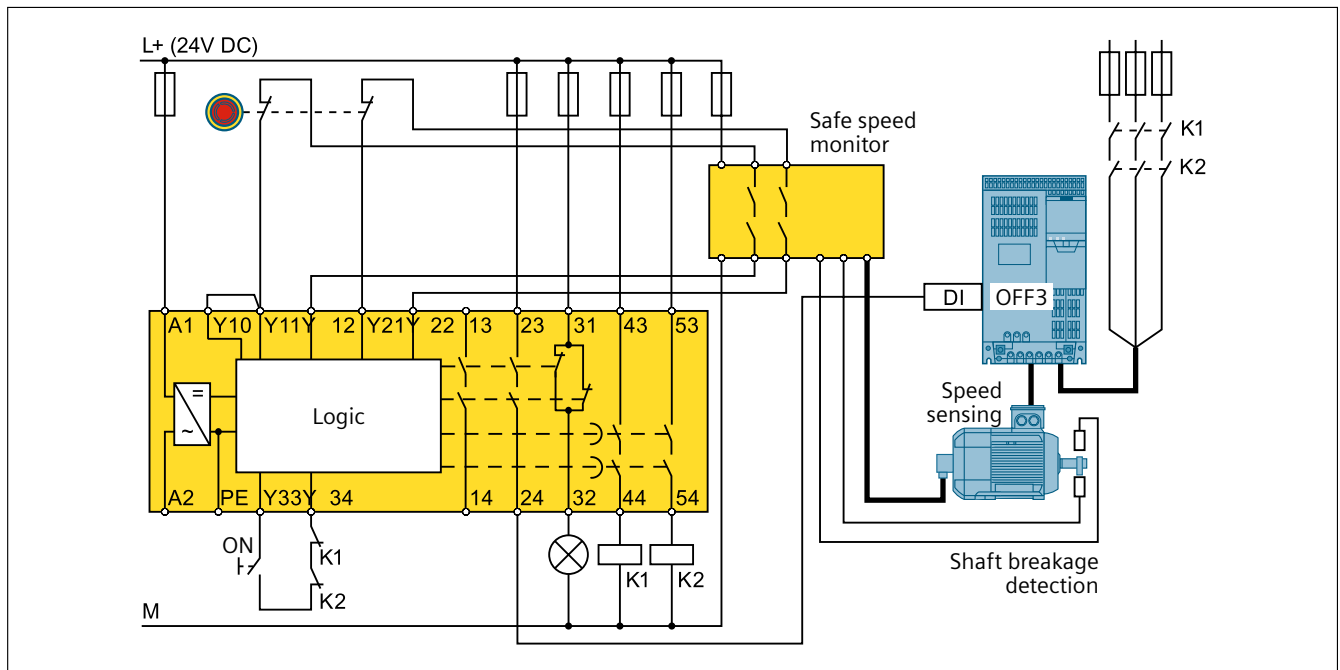

Figure 2-9 Safely monitoring the speed – classic solution using an external circuit

Solution with "Safety Integrated"

You can eliminate both encoders if you implement the same functionality using a converter and a certified "Safety Integrated" function.

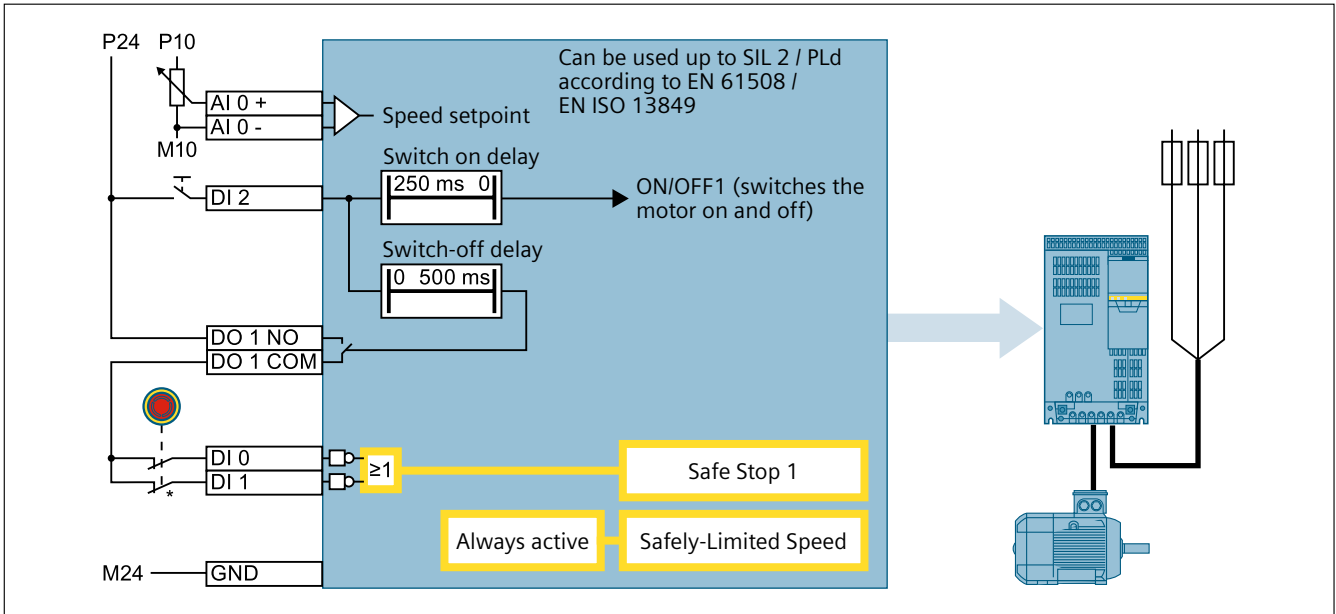
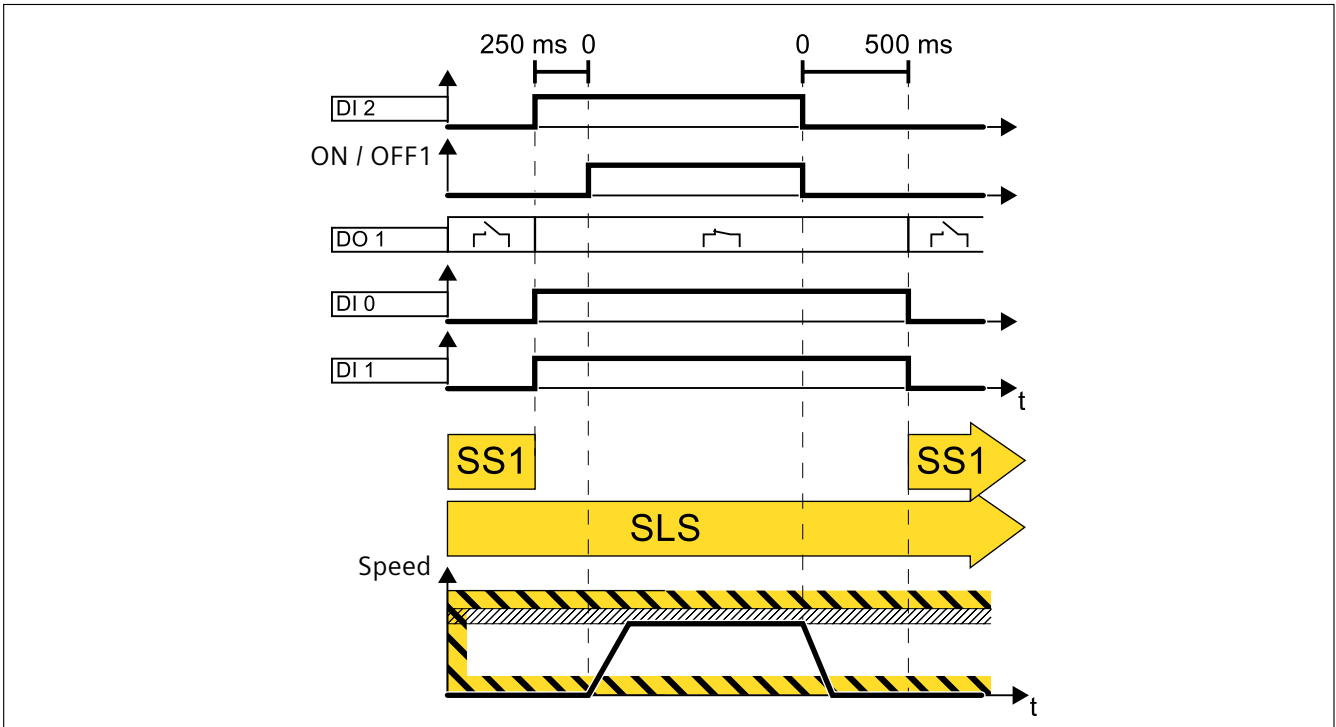

Figure 2-10 Safely monitoring the speed – solution with „Safety Integrated“

*Short-circuit free cable routing according to EN ISO 13849-2 is required.

The "Safely-Limited Speed" function is always active in the converter. The converter continually monitors the motor speed using this function. The converter stops the motor when an excessively high speed is reached.

As already mentioned above, the special converter architecture allows the speed of an induction motor to be monitored – even if it is not equipped with an encoder. The encoderless speed monitoring functions as long as the motor is switched on – which means as long as the converter senses the motor currents and voltages. The converter can no longer directly monitor the motor speed when the motor is switched off.



As a consequence, after the motor has been switched off, the drive goes into a "safe state": The converter automatically initiates the "Safe Torque Off" function to safely prevent the motor actively accelerating.

The converter only exits this safe state if it receives an external "Select STO" or "Select SS1" command.

If you route the command to switch on the motor through two internal delay blocks in the converter, as described above, the motor without encoder can be switched on and switched off with safety-related monitoring seamlessly active.

2.3.2 Paper logistics in a printing machine

The „Safely-Limited Speed“ function is suitable for the widest range of applications. Machine builders must also safely limit the speed or velocity in the following application involving feeding paper into a printing machine.

The printing machine itself is secured using a fence and a light barrier and this will not be discussed any further here. We would like to focus on the relative basic application that supplies a printing machine with paper.

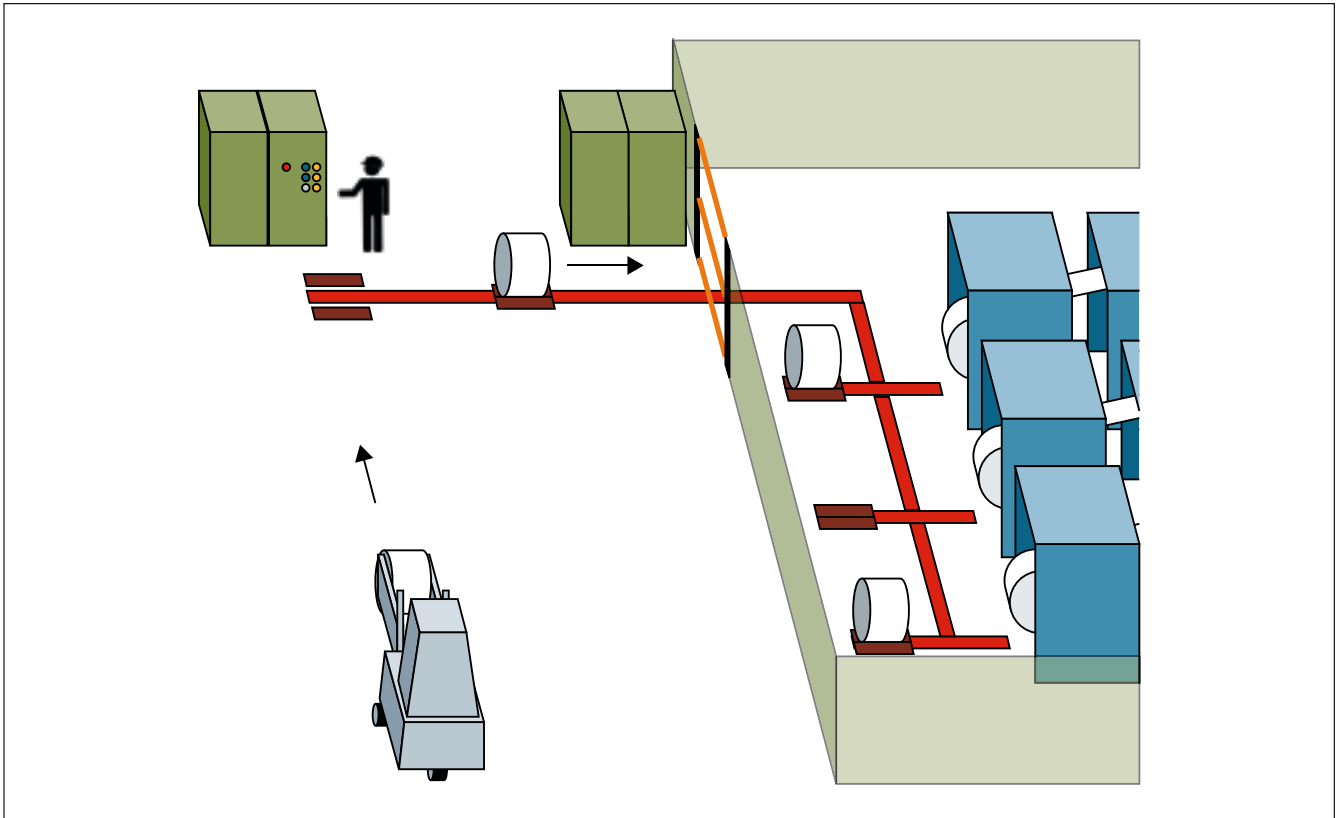
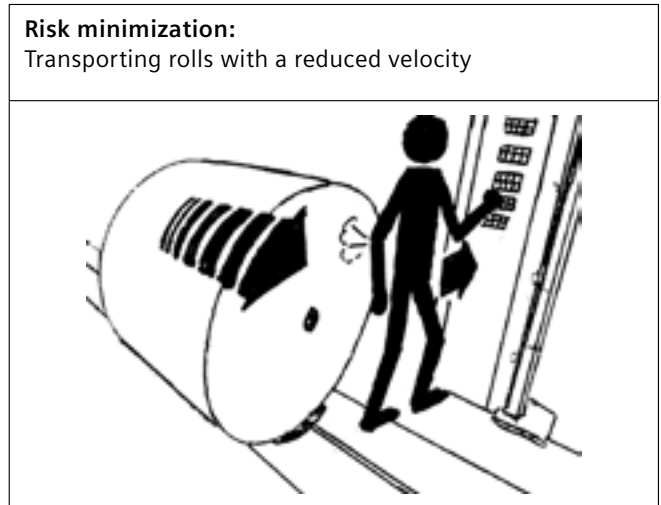
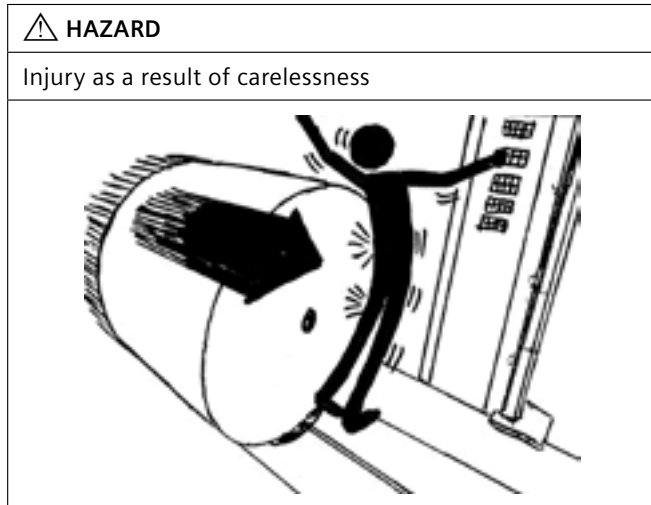

Figure 2-11 Paper logistics in a printing machine

Forklift trucks deliver rolls of paper from the warehouse at the interface to the automated printing machine. The machine operator removes the packing material, weighs and adjusts the paper rolls that have been transported there. A conveyor then automatically transports the paper rolls to the roll carrier unit in the printing machine.

This automated roll transport represents a hazard for machine operators.



Solution with "Safety Integrated"

Just the same as in the last example („lathe“), also here the „Safety integrated“ function „Safely-Limited Speed“ is always active in the converter. However, in this case,

the command to switch on and switch off the motor is now received from the higher-level control system via the PROFINET interface.

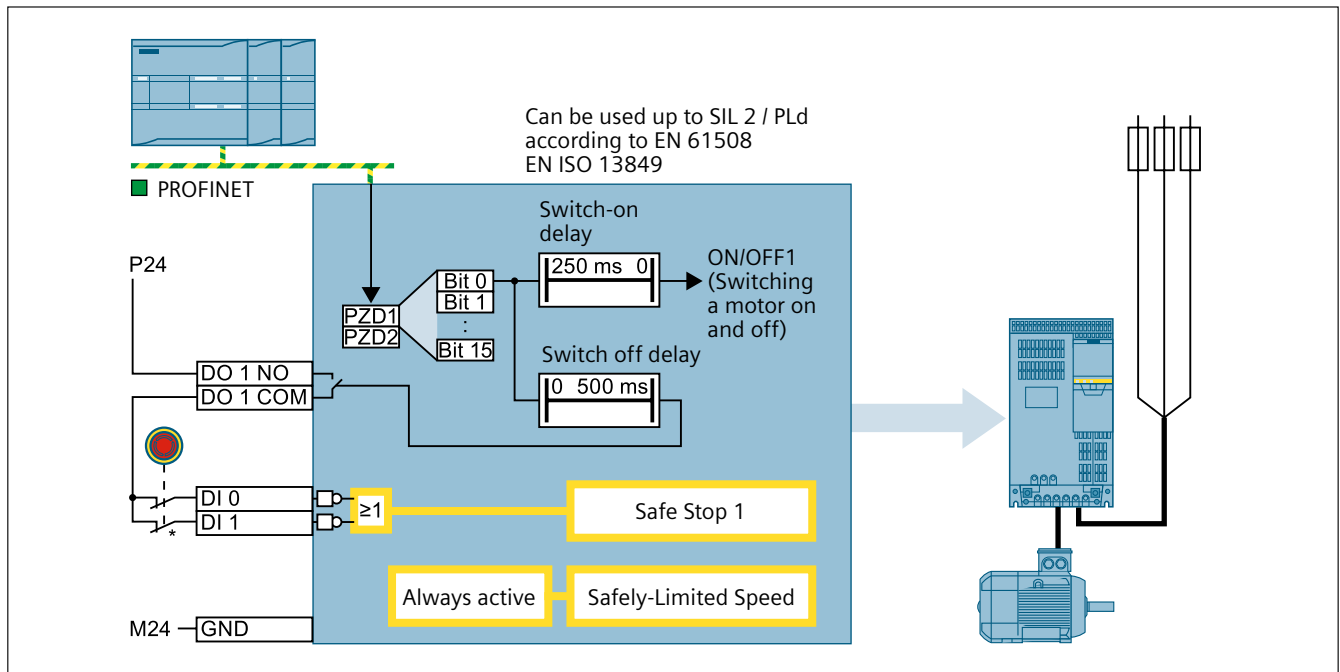

Figure 2-12 Safely monitoring the speed – solution with „Safety Integrated“

*Short-circuit free cable routing according to EN ISO 13849-2 is required.

2.3.3 Commissioning the „Safely-Limited Speed (SLS)“ function with Startdrive

You enable the „Safety Integrated“ function „Safely-Limited Speed“ using Startdrive. The drive allows safety functions to be assigned to a specific safety-related input, and also

allows these functions to be permanently activated. This reduces the number of input terminals required.

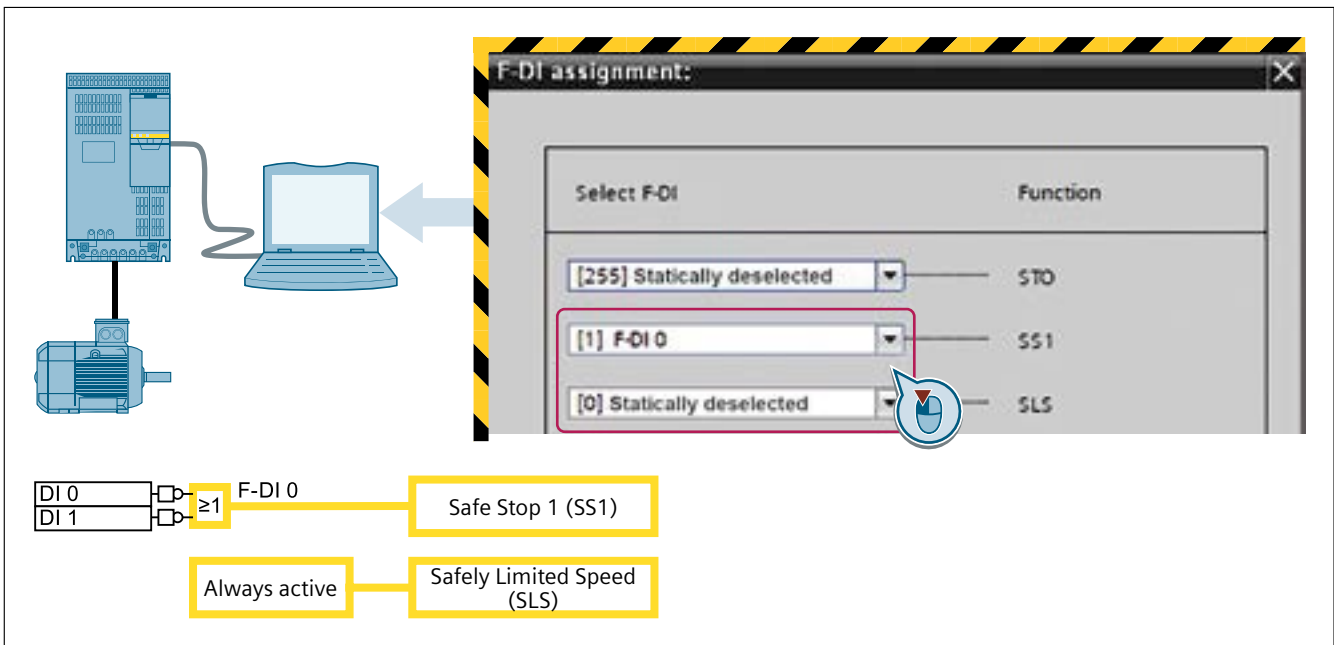

Figure 2-13 Assigning the safety-related input to function SS1 and to select that the SLS function is always active

You must set the following for the "Safely-Limited Speed" function:

- The speed that the drive monitors.
- The value to which the drive limits the speed
- The response of the drive if the motor is too fast:
 - STOP A: The motor coasts down to standstill.
 - STOP B: The converter brakes the motor down to standstill.

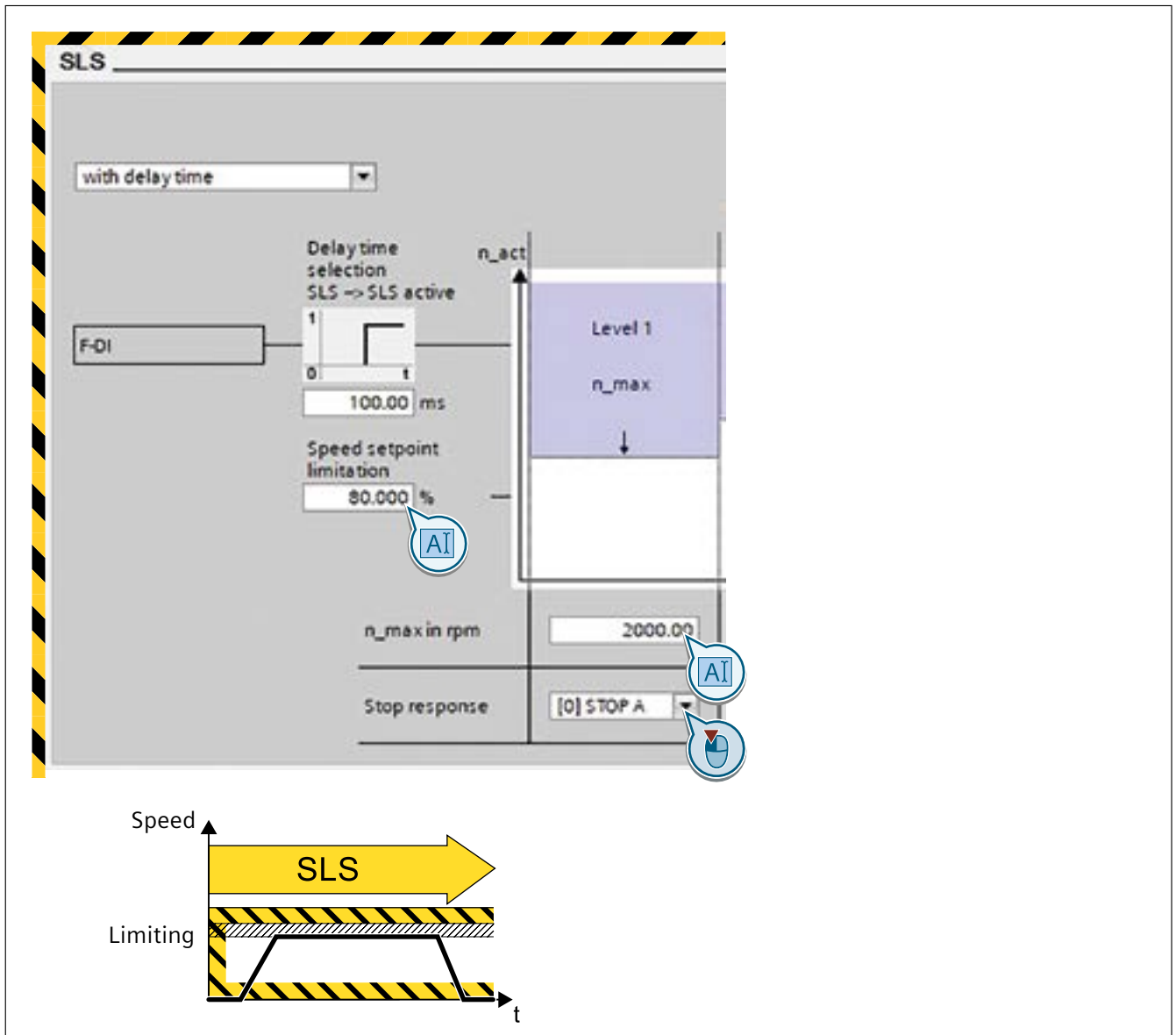

Figure 2-14 Monitoring, limiting and stop response of the SLS function

2.4 Safely turning in a specific direction

Just the same as in the last section, this also involves monitoring speeds. However, the hazard sometimes does not arise as a result of the absolute speed value, but instead, the direction of rotation.

2.4.1 Gate drive

In a plant, a gate opens when requested and automatically closes again after a certain time.

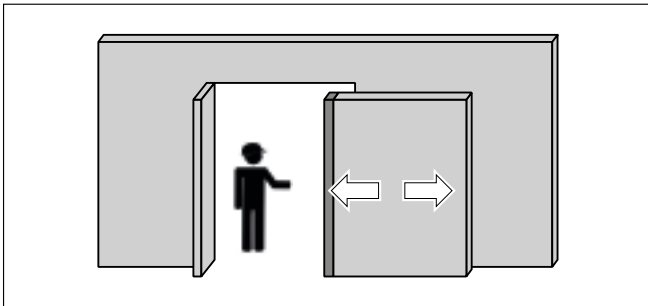

HAZARD

The gate closes and an inattentive person gets trapped and injured.

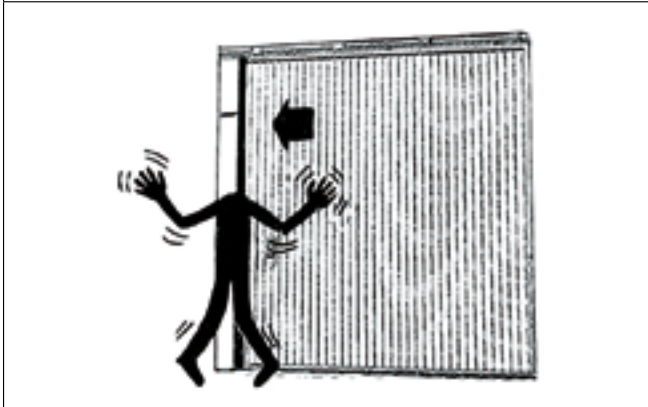

Risk minimization:
The drive stops on contact.

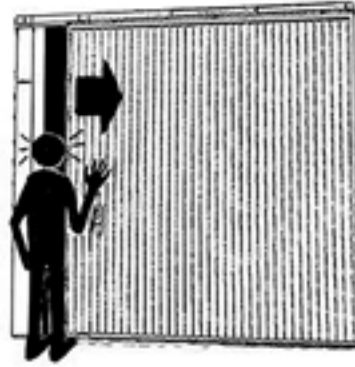

Stopping a gate drive can be implemented using relatively basic measures. However, it is possible that the person involved cannot free himself without external help. When an attempt is made to free a person that has become trapped, then the gate must safely open and not reclose under any circumstance.

Is there a classic solution using an external circuit?

There is no classic solution based on an external circuit for monitoring a direction of rotation.

You must engineer, program and commission a solution based on a standard drive without "Safety Integrated" using the following parts:

- A motor with encoder to sense the speed.
- A higher-level, failsafe control system.
- A converter with PROFIBUS interface.
- A PROFIsafe connection between the converter and control system.
- A safety program in the control system that evaluates the speed signal of the converter as well as the encoder, which it uses to monitor the direction.

Solution with „Safety Integrated“

The „Safe Direction“ function in the converter is a certified function, which independently monitors the direction of rotation of the connected motor – also in this case, without using an encoder.

The converter only requires the sensor signal that either inhibits or releases the hazardous direction of rotation and a connection to the higher-level control system.

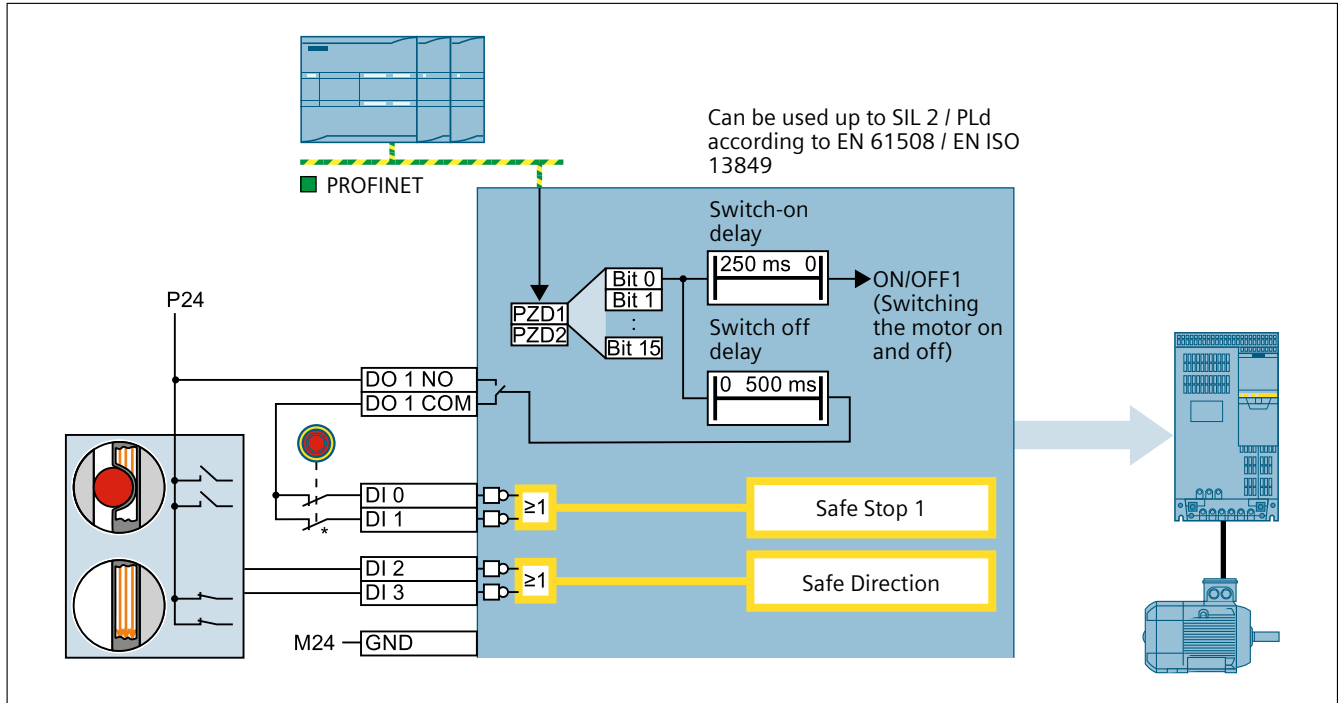

Figure 2-15 Rotating safely in a certain direction – solution with „Safety Integrated“

*Short-circuit free routing according to EN ISO 13849-2 is required.

An elastic sensor at the front side of the gate for example is suitable for sensing if a person has become trapped in the gate. A beam of light is transmitted through the sensor, which is interrupted when mechanical pressure is applied.

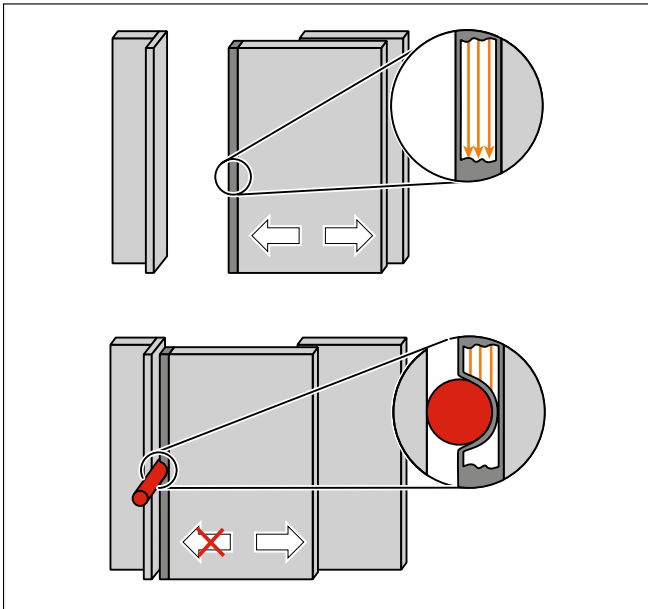





Figure 2-16 Sensor to protect against entrapment

If a hazard is detected, then the drive stops the gate and inhibits the closing direction of rotation. After switching on again, the drive can only open the gate.

2.4.2 Cleaning printing rolls

Maintenance personnel must enter the machine to clean the printing rolls. Personnel must turn the printing rolls to be able to completely clean them.

 HAZARD
Injury when body parts are drawn or pulled in.

Risk minimization: The print rolls may only rotate in one direction.

Solution with "Safety Integrated"

The converter with "Safety Integrated" evaluates a maintenance switch, which controls the "Safe Direction" function and inhibits the hazardous direction of rotation.

2.4.3 Commissioning the „Safe Direction (SDI)“ function using Startdrive

„Safety Integrated“ functions are assigned to a safety-related input using Startdrive. The „Safe Direction“ function can be selected separately for every direction of rotation.

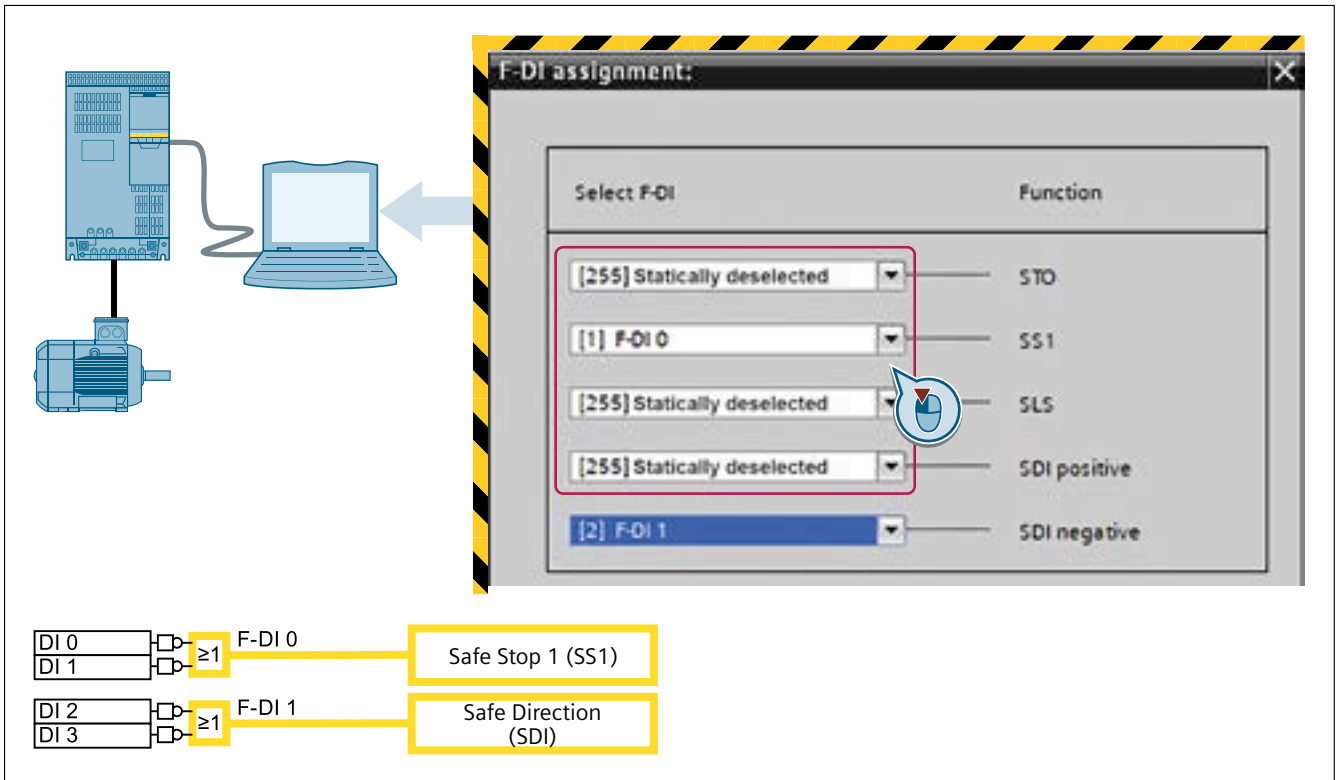

Figure 2-17 Assigning functions SS1 and SDI to safety-related inputs

After selecting the function, the converter waits for a specific time before it monitors the direction of rotation.

When setting the converter, you must adapt the delay time to the motor braking time.

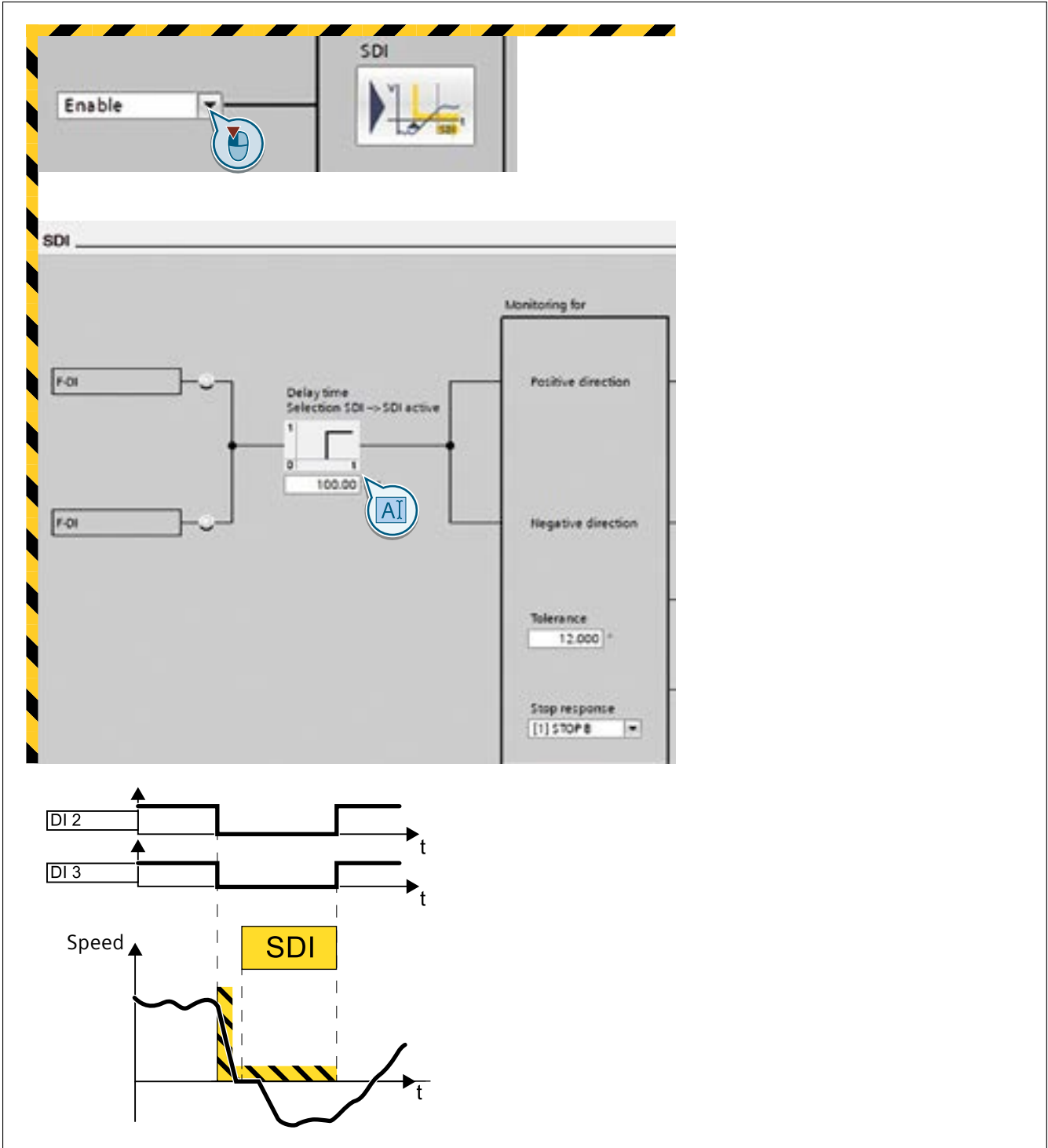

Figure 2-18 Enabling the SDI function and setting the monitoring delay time

"Safety Integrated" – an overview of the functions

Integrated safety functions

Failsafe drives set themselves apart as a result of integrated safety functions, which provide users with possible responses to safety-related events. Safety Integrated functions that are available in Siemens drives are subsequently described. Regarding functional safety, all of the functions comply with the requirements defined in the Part 5-2 of International Standard IEC 61800 for variable speed drive systems. Functions SBT and SP go beyond the scope defined in IEC 61800-5-2.

Functions to safe stopping

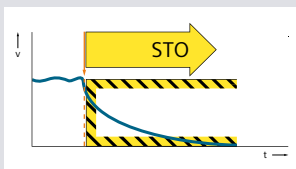

Safe Torque Off (STO)

STO safety sets the drive into a torque-free condition: an undesirable restart is safely prevented. A fast restart is possible after STO has been deselected as the DC link remains charged.

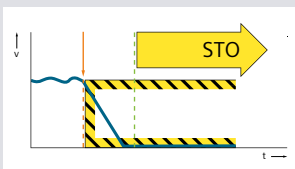

Safe Stop 1 (SS1)

The drive is quickly stopped and safely monitored, especially for high moments of inertia.

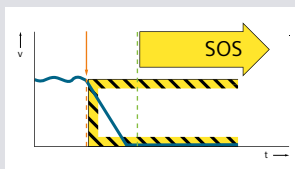

Safe Stop 2 (SS2)

The drive is quickly stopped and safely monitored and then SOS is activated.

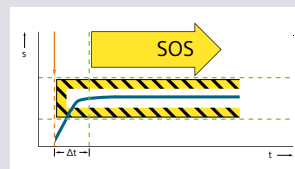

Safe Operating Stop (SOS)

The motor position is safely monitored and then SOS is monitored at standstill for each drive control.

Functions for safe brake management

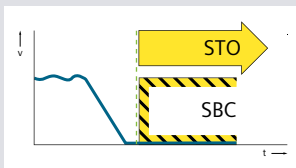

Safe Brake Control (SBC)

A holding brake is safely controlled and monitored, especially for vertical axes; is always activated in parallel with STO.

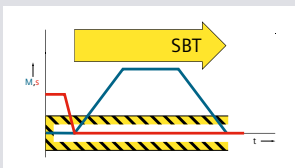

Safe Brake Test (SBT)

Using the SBT diagnostic function up to two brakes per axis can be cyclically tested.

Functions for safely monitoring drive motion

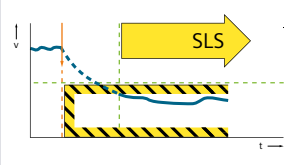

Safely-Limited Speed (SLS)

A specific speed/velocity limit value of a drive is safely monitored – and a configurable stop response is initiated when the limit value is exceeded.

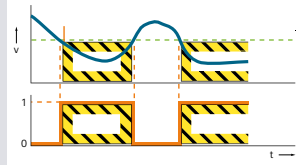

Safe Speed Monitor (SSM)

The safe speed/velocity monitor function supplies a safety-related signal as long as the drive operates below a specified speed/feed rate velocity.

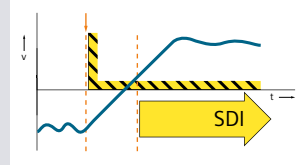

Safe Direction (SDI)

The direction of rotation is safely monitored so that the drive can only move in the permissible direction; if the drive moves in the incorrect direction, then a configured fault response is initiated.



Safely-Limited Acceleration (SLA)

Safely monitors that the drive does not exceed a preset acceleration limit value.

Functions for safely monitoring the position

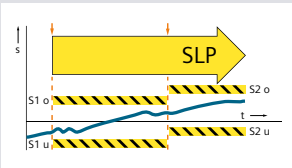

Safely-Limited Position (SLP)

Protective zones/areas are safely monitored using defined traversing ranges.

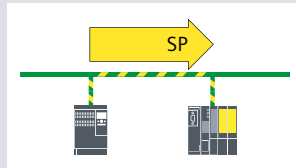

Safe Position (SP)

The SP function transfers safety-related position actual values of the drive to the F control for further processing via PROFIsafe.

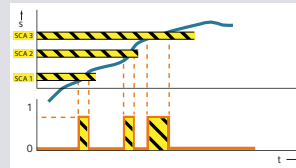

Safe Cam (SCA)

Safe cams supply a safety-related signal as long as the drive operates within a specified position range.

4

Minimizing risks in plants, systems and machines

„Safety Integrated“ functions play an essential role when it comes to functional safety of plants, systems and machines. Functional safety means that all parts of the machine function correctly and have suitable and sufficient equipment to minimize risks.

In addition to functional risks, plants, systems and machines have a series of other sources of potential hazard.

Based on risk analysis, risk assessment and measures to minimize risk, you can create a safe plant, system or machine. This can be achieved in several iterations.

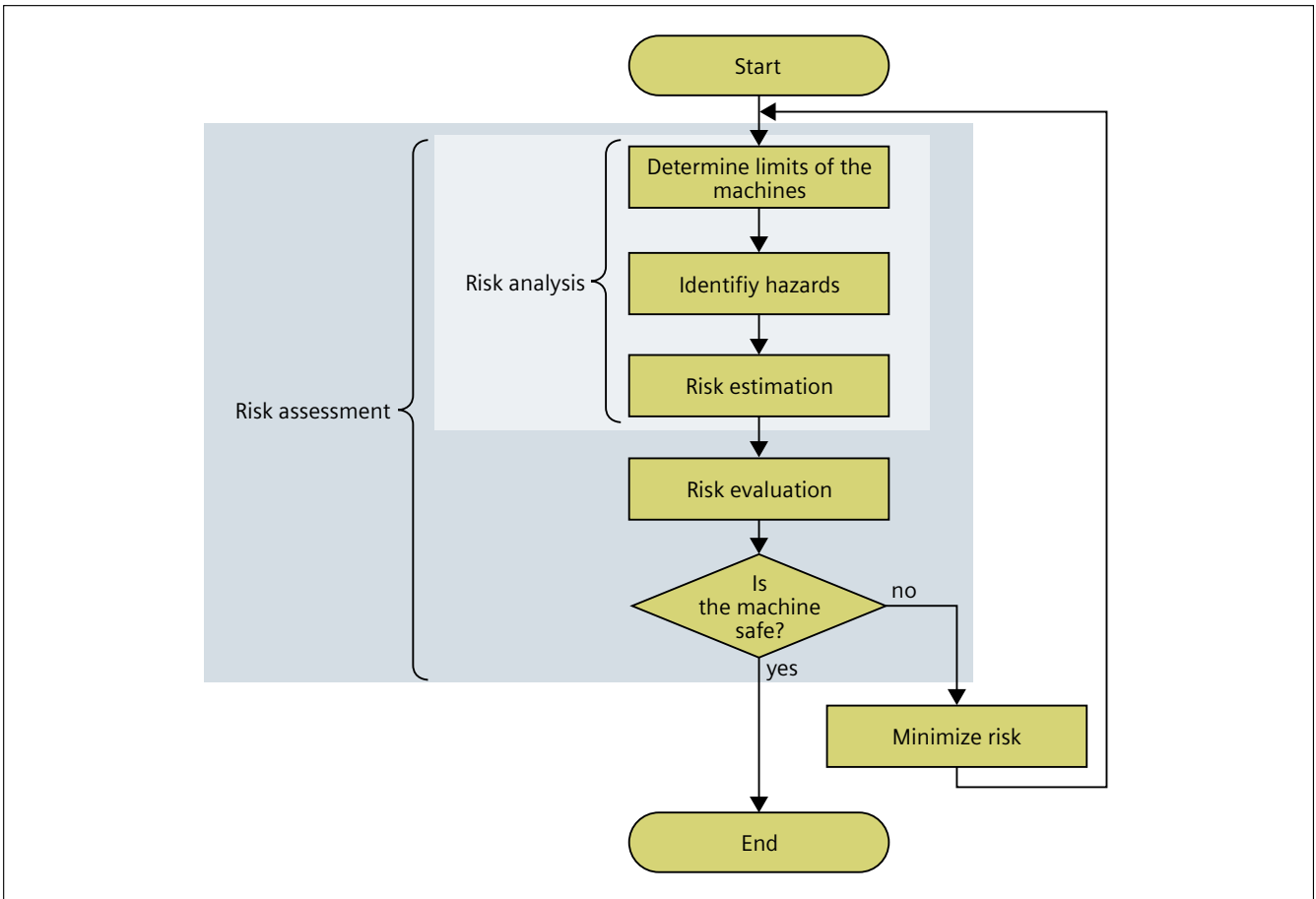

Figure 4-1 Risk analysis and risk assessment of a plant, system or machine

Define the machine limits	Determine the area in which the machine represents a hazard for persons or material assets.
Identify hazards	<p>Systematically identify hazards:</p> <ul style="list-style-type: none"> • Mechanical hazards • Electrical hazards • Thermal hazards • Hazards due to noise • Material/substance hazards, chemical hazards • Ergonomic hazards • Hazards in conjunction with the usage environment • Combination of hazards <p>Analyze these hazards for each phase of the service life of the machine:</p> <ul style="list-style-type: none"> • Transport, mounting, installation • Commissioning • Operation in all operating modes: Normal operation and operating with an active fault • Cleaning, maintenance and repair • Decommissioning, disassembly and disposal
Estimate and evaluate the risk	Based on the identified hazards, you must estimate the risks according to the extent of damage and the probability of occurrence and then assign priorities.

For the risk analysis and risk assessment, Siemens provides the Safety Evaluation Tool as free-of-charge support. The tool navigates you in considerable detail and in a structured fashion through the complete process and documents your analysis and assessment. See also: Additional information on „Safety Integrated“ (Page 30).

If the risk assessment indicates that measures are required to either remove risks or minimize them, then carry out measures to minimize risk in the following sequence:

1. Minimize risks by improving safety relating to the design and construction of the plant, system or machine.
2. You must implement additional technical protective measures for risks that cannot be resolved through design and construction measures of the machine. Technical protective measures also include the installation of electronic safety equipment. e.g. sensors and drives with „Safety Integrated“.
3. You must tell users about residual risks by providing them with the appropriate information, e.g. warning labels, documentation and/or training.

It goes without saying that as machine builder (OEM) you must fully comply with legal regulations relating to the marketing of machines. For example:

- You must verify that the machine is in full conformance with what is laid down in the Machinery Directive.
- When fabricating the machine, you must carefully check all measures that are applied to minimize risks.

Additional information on "Safety Integrated"



Additional information on Safety Integrated is available on the home page:
Safety Integrated (www.siemens.com/safety-integrated).

The Safety Evaluation function for the TIA Selection Tool is available at the following address
(<https://new.siemens.com/global/de/produkte/automatisierung/themenfelder/safety-integrated/fertigungsautomatisierung/support/tia-safety-evaluation-tool.html>).

The Safety Integrated Function Manuals provide a detailed description of the safety functions.

For drives with SINAMICS G120, G120C or G120D:
SINAMICS G Function Manual (<https://support.industry.siemens.com/cs/ww/en/view/109782490>).

For drives with SINAMICS S120:
SINAMICS S Function Manual (<https://support.industry.siemens.com/cs/ww/en/view/109781722>).

Additional information

SINAMICS converters:

www.siemens.com/sinamics

Safety Evaluation Tool:

www.siemens.com/safety-evaluation-tool

Published by

Siemens AG

Digital Industries

Motion Control

P.O. Box 31 80

91050 Erlangen, Germany

Subject to change without prior notice

Article No. DIMC-B10078-00-7600

Dispo 21500

Printed in Germany

WÜ/1000173743 PA 1121 PDF

© Siemens AG 2021

