

SIEMENS



Document No: 0072

SpecTRON 5 Connector Operations Manual

Protection, Storage, Shipment, Unpacking, Deployment
and Maintenance Instructions

www.siemens.com/energy/connector-operations-manual

SpecTRON 5 PROTECTION, STORAGE, SHIPMENT, UNPACKING, DEPLOYMENT & MAINTENANCE INSTRUCTIONS

General

Thank you for purchasing a Siemens Subsea SpecTRON 5 product. The information that follows is an overview of the protection, storage, shipment, unpacking, deployment and maintenance instructions for Siemens Subsea SpecTRON products.

Siemens Subsea recommends the termination of all equipment only be undertaken by suitably trained and qualified personnel.

Revision Details:

Rev 0	First Issue	06/10/09	N. Knight	W. Barrett
Rev 1	- AquaTRON 2" Bend Radius detail added (Page 4) - SpecTRON naming convention corrected throughout the procedure - Note added to 4.2 – "Project Specific Connector storage Temperature may vary".	24/11/11	P.Edmondson	S.Spencer
Rev 2	-Added section 2 – Specification -Added section 3 - Marking -Added section 4.1 – Lifting of Jumpers & Connectors -Added section 5.1 – Protective caps. -Section 7.1.4 - Replaced SpecTRON 10 cleaning figure with SpecTRON 5 connectors. -Made procedure generic to cover Penetrators as well as Connectors. -Section 7.1.6 - Added Snohvit type connectors to post mating check. -Section 7.1.4 - Jet washing in Receptacle shroud allowed provided no Multilam / Bal spring fitted. Added Section 9 - Installation	13/8/12	W. Barrett	C.Plant
Rev 3	1 – Clarified both Dummy Plugs and Receptacles are covered by this document. 2.2 – Handling Temperature added of -25°C to +70°C. 4.1 – Corrected typo to refer to	7/11/12	W. Barrett	C. Plant

	<p>figures 4 & 5. 7.1.1 – Added information regarding unmated plugs in seawater. 7.1.1 – Clarified 28 days exposure time to Receptacles only.</p>			
Rev 4	<p>Front cover updated 1.0 – add product safety to scope 2.0 - Incorporate HSE & Product safety Information 11.0 - Information & Notes Table</p>	07-03-14	M. Gretton	B. Leach
Rev 5	<p>New Front cover design & web link added</p>	1-05-14	K.Mutton	W.Barrett
Rev 6	<p>2.0 – Additional note to HSE section regarding unmated receptacles</p>	05-06-14	M.Gretton	B.Leach
Rev 7	<p>Section 10.2- more detailed added with images to the routing of hose. Section 10.2.1 formers added as recommended designs for formers. Sections 10.2.2 added to define routing of hoses in fix installations Section 10.2.3 added to define routing of hoses in dynamic installations</p>	17/12/15	J.Keith	M.Earnshaw

Contents

1.	SCOPE	4
2.	HEALTH & SAFETY	4
3.	SPECIFICATION	5
3.1	ELECTRICAL.....	5
3.2	ENVIRONMENTAL.....	5
3.3	HOSE & CABLE	5
4.	MARKING	6
5.	PROTECTION, HANDLING AND SHIPMENT	7
5.1	LIFTING OF JUMPERS & CONNECTORS.....	8
6.	UNPACKING	10
6.1	PROTECTIVE CAPS	10
7.	STORAGE	12
7.1	SHORT TERM STORAGE.....	12
7.2	LONG TERM STORAGE	12
8.	DEPLOYMENT & MAINTENANCE	13
8.1	SpecTRON 5	13
9.	MANUALLY MATING/ DE-MATING ROV CONNECTORS	20
9.1	MATING PROCEDURE	20
9.2	DE-MATING PROCEDURE	22
10.	INSTALLATION	23
10.1	CONNECTOR & PENETRATOR INSTALLATION	23
10.2	HOSE MANAGEMENT, ROUTING AND SUPPORT	23
11.	INFORMATION & NOTES / HEALTH & SAFETY FEEDBACK	29

1. SCOPE

This procedure includes information on the following connector types

- SpecTRON 5 ROV Plugs
- SpecTRON 5 ROV Receptacles
- SpecTRON 5 Penetrators
- SpecTRON 5 ROV Dummy Connectors (Plugs & Receptacles)
- SpecTRON 5 ROV Parking Receptacle

Any information, records or Health and Safety feedback that needs to be detailed, can be recorded in the punch list at the rear of the document

2. HEALTH & SAFETY

Manual Handling, Lifting and Carrying are known to be the largest contributors to occupational ill-health.

Ensure that mechanical handling aids are used whenever possible to avoid manual handling. Where manual handling is considered appropriate for the task safe lifting guidelines must be followed, e.g. adopt correct posture, consider team lifting, employ safe lifting technique, etc. Only competent persons are permitted to perform tasks without supervision, if in doubt ask. Good Housekeeping avoids Slips Trips and Falls, keep your area clean and tidy.

It is the operator's responsibility to comply with current Company & regional health and safety legislation.

Caution shall be exercised during assembly to ensure that fittings and hydraulic / pneumatic equipment are properly installed.

In the event of a safety incident or any safety improvement suggestions, please contact the Health & Safety Department at prodsafe.gb@siemens.com and/or complete and return the punch list in section 11.0.

Note – All receptacle's (male pins) must be mated to its correct mating half before it is energised (this includes the correct Test, Dummy and Wet Mate Pair).

3. SPECIFICATION

The following is a basic specification for SpecTRON 5 connectors. Actual product may vary. Please refer to product specific data sheet or Project specific Design Input Document for more detailed information.

3.1 ELECTRICAL

Rated Voltage: 2.9/5(5.8)kV or 3.6/6(7.2)kV
Rated Frequency: 1-100Hz
Rated Current: 150A

3.2 ENVIRONMENTAL

Storage Temperature: -40°C to + 70°C
Handling Temperature: -25°C to +70°C
Operating temperature: -4°C to + 20°C
Max Deployment Rate: 20bar / min
Max Water Depth: 1330 m

3.3 HOSE & CABLE

3.3.1 AquaTRON 200 (2" bore)

Outside Diameter: 66 mm
Minimum Bend Radius: 375 mm
Weight in Air (Inc cable and oil): 4.3 kg/m
Weight in Water (Inc cable and oil): 0.79 kg/m
Storage Temperature: -40°C to + 70°C

3.3.2 Gorilla (1.5" bore)

Outside Diameter: 51.8 mm
Minimum Bend Radius: 375 mm
Weight in Air (Inc cable and oil): 2.8 kg/m
Weight in Water (Inc cable and oil): 0.64 kg/m
Storage Temperature: -25°C to + 70°C

4. MARKING

Siemens Subsea Connectors and Penetrators are marked with the Siemens Subsea part number and unique serial number. Marking locations are typically on the Plug Nose and Receptacle Shroud for Wet Mate Connectors and on the Flange of Penetrators. Figure 1 shows the typical marking locations for a Plug and Receptacle. Marking is typically by laser etching.

Harnesses are also marked with the Siemens Subsea part number and unique serial number for the harness as shown in Figure 2. Client and project specific information is also usually added to these labels. Labels are typically black text on a yellow background underneath clear heatshrink. Typically, labels are located at each end of the harness and also centrally.

Marking of Siemens Subsea Part No and Serial No for individual

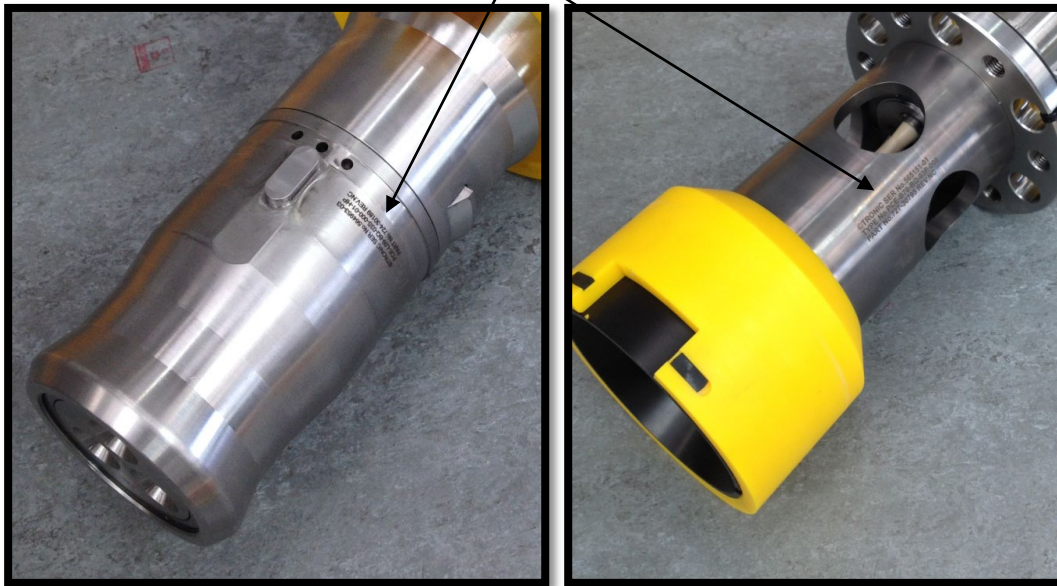

Figure 1 – Marking of Connectors

Marking of Siemens Subsea Part No, Serial No and client information on harnesses



Figure 2 – Marking of Hoses

5. PROTECTION, HANDLING AND SHIPMENT

Siemens Subsea electrical connectors are manufactured primarily from materials such as 316L stainless steel (UNS S31603), and Super Duplex stainless steel (UNS S32550). Stainless steel 316L (UNS S31603) connectors and penetrators must be connected to a CP (Cathodic Protection) system at all times in order to withstand harsh saliferous environments. Super Duplex stainless steel (UNS S32550) connectors and penetrators should be isolated from the CP system to reduce the possibility of hydrogen embrittlement and withstand harsh saliferous environments. However, the connector insert and exposed parts are susceptible to mechanical damage if not adequately protected. Dust caps are fitted to all Siemens Subsea connectors before transport, but can be fitted with protective caps if specified by the customer. Caps are recommended to remain in place until connectors are deployed subsea.

The connectors can be shipped singularly or in multiples. Care should be taken to protect the connector with bubble wrap or similar wrapping materials to avoid surface damage during transit. If large numbers are shipped in one consignment a suitably reinforced box will be necessary to withstand the weight. Protection caps must be fitted at all times during transport.

If storage is carried out in saline conditions, e.g. on a ship's deck or hold, then full dummy connectors should be used.

Bulkhead type connectors with exposed tailing wires should be packed and shipped in a suitably sized box to allow adequate space for the tailing wires without bending or kinking.

If the connectors are assembled onto hoses these must be suitably coiled and secured with tape to prevent uncoiling during transit. The following bend radii are recommended for storage/transport of hoses.

- Gorilla 1.5" NB – Minimum bend Radi – 250mm
- AquaTRON 2" NB (AquaTRON 200) - Minimum bend radii - 375mm

Connectors are designed to withstand vibration that occurs during transportation and to withstand being dropped from a height of 1m whilst in packaging.

Figure 3 shows how a SpecTRON 5 harness is packaged. The connectors on either end of the harness have a transportation cap fitted and are surrounded in bubble wrap. The base of the shipping crate is lined with protective packaging and the harness is positioned so that the hose can be coiled without kinking. Any loose items are placed in a box inside the crate. Protective packaging is then placed on top of the harness and secured in place with a wooden baton, before the lid of the crate is screwed down.



Figure 3 – Packaging

5.1 LIFTING OF JUMPERS & CONNECTORS

SpecTRON 5 harnesses typically weigh in excess of 30 kg and hence should not be manually handled. Refer to the specific harness drawing for weight and length details. The connectors can be safely slung around the locations shown in Figure 4 and Figure 5. The centre of gravity for the Connector or Penetrator is usually marked on the outline drawing (supplied in documentation pack) but must be verified at low level before commencing any lift.

For SPO or API flange penetrators, lifting eye mounting holes are provided on the flange at 12 and 6 o'clock positions.

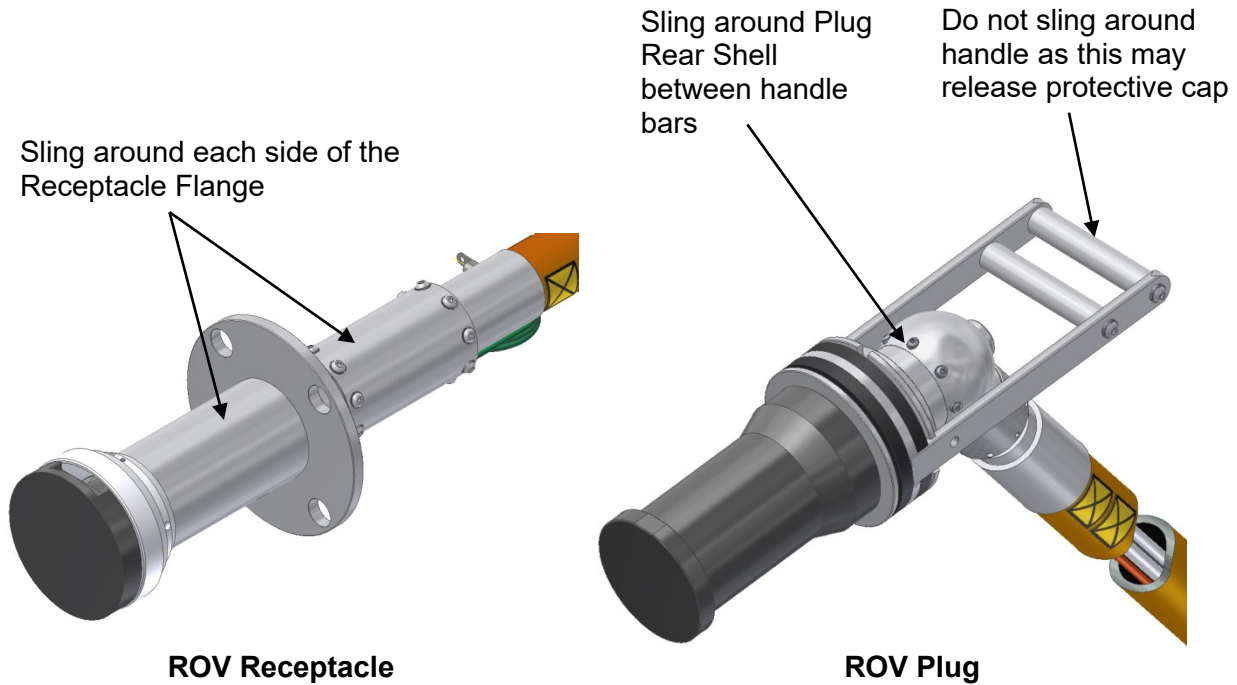

Figure 4 - Recommended lift positions – Plug & Receptacle

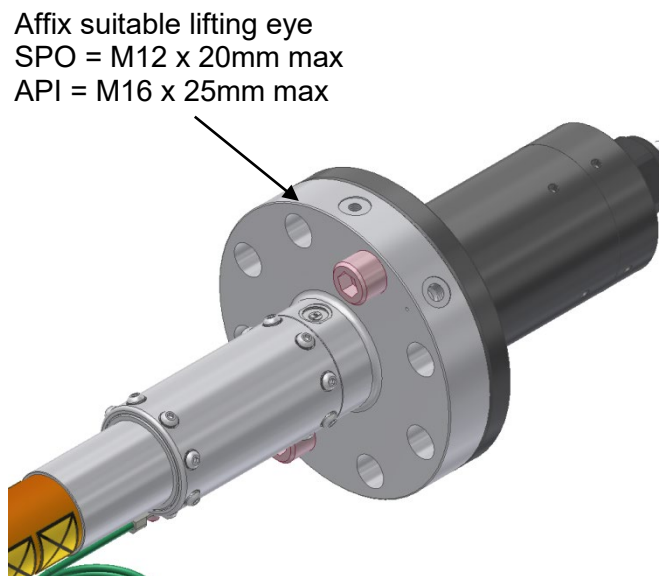

Figure 5 - Recommended lift positions - Penetrators

Dummy, or parking connectors weigh less than 15 kg and can be lifted by hand, however correct lifting practice should be observed at all times.

CONNECTORS/PENETRATORS SHOULD NEVER BE LIFTED BY THE HOSE OR CABLE, AS THIS PLACES UNNECESSARY STRAIN ON THE CONNECTOR INTERNALS AND MAY RESULT IN LOSS OF CONTINUITY.

On harnesses, the cable or hose should be supported during lifts to minimise strain on the Connector/Penetrator. The maximum recommended length of hose which can be unsupported during a lifting operation is **5 meters**.

Protective caps should remain on wherever possible during lifting operations to minimise the risk of damage to connector sealing or electrical components. This particularly applies to penetrators.

6. UNPACKING

Remove wrapping material taking care to inspect for any surface damage or items that may have become separated from the connector, such as 'O' seals. Do not use a knife to cut the wrapping material, as this may cause damage to any elastomeric parts of the connector. Do not remove protection caps until connectors are ready for installation. On removal do not allow the hoses to drag over the edges of the packing crate.

6.1 PROTECTIVE CAPS

All SpecTRON 5 Connectors/Penetrators come supplied with a protective cap. These can either be dust caps, protective caps or IP caps (Ingress Protection caps). Dust caps (typically yellow in colour) can be simply removed by twisting or pulling them off. Protective caps and IP caps (typically black in colour) can be removed as detailed below.

6.1.1 ROV Plug Cap

The ROV Plug cap is latched onto the Plug connector via the connector latching mechanism. In order to remove the cap, it is recommended that the operator stand the Plug vertically on the cap, stand on the flange of the cap and pull on the ROV handle of the Plug connector. This will disengage the latching mechanism of the Plug. Do not try to pull the cap directly off the plug as this may damage the latching mechanism of the Plug.

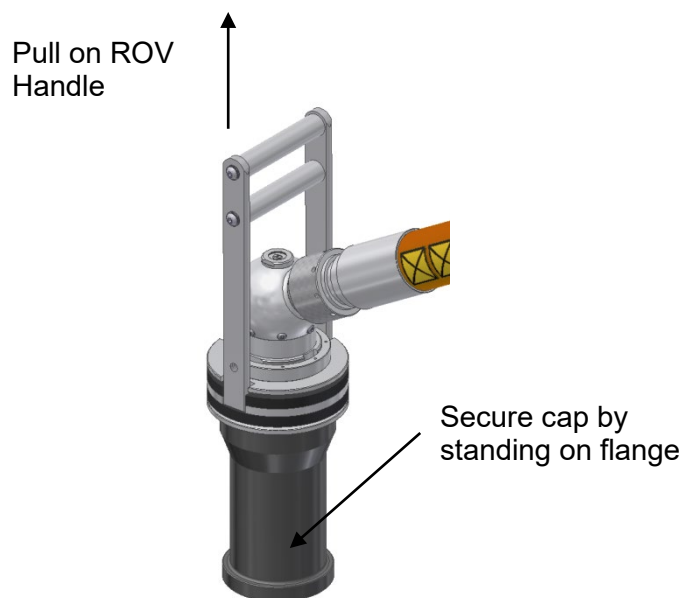

Figure 6 - ROV Plug Cap

Refitting the Plug cap can be done by simply pushing the cap back onto the nose of the plug until the latching mechanism of the plug engages.

6.1.2 ROV Receptacle Cap

The ROV Receptacle Cap can be removed by simply securing the Receptacle via suitable means (if not already mounted to the structure) and then pulling on the cap. Slots are provided on each side of the cap to allow finger access and easy removal.

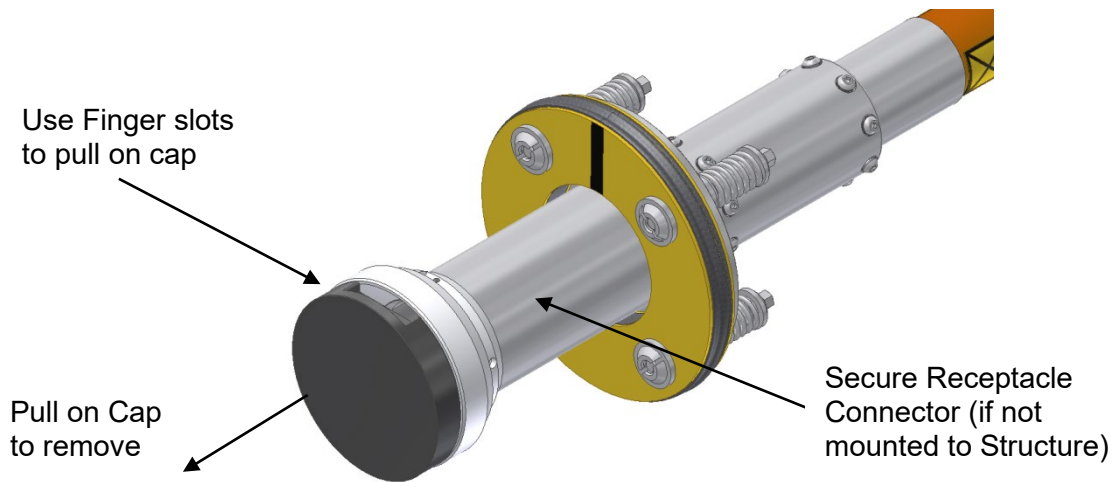

Figure 7 - ROV Receptacle Cap

Refitting the Receptacle cap can be done by simply pushing the cap back into the Receptacle shroud until the spring plungers engage, locking the cap into place.

6.1.3 Penetrator Cap

Penetrator caps would usually be removed by Siemens Subsea site engineers during the termination of the Penetrator to the module. It is recommended that only trained personnel remove Penetrator caps though details are provided here for information only. Penetrators may be supplied with pre-terminated tails which are sealed with a cable gland. This should be slacked off prior to removal of the cap. To remove the cap, unfasten the 2 cap head screws using a suitable allen key and then simply slide the cap off the internal termination of the Penetrator, over the tails.

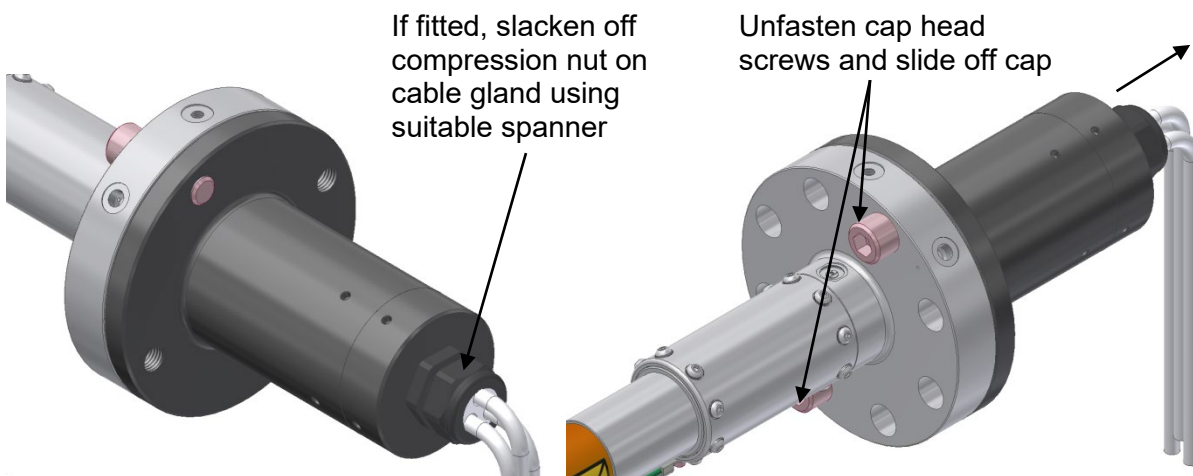

Figure 8 - Penetrator Cap

Refitting the Penetrator cap is a reversal of the removal procedure.

7. STORAGE

7.1 SHORT TERM STORAGE

Prior to installation the connectors are sensitive to environments where grit and dirt are present. To prevent ingress of the above, they should be stored in a clean dry area and be protected by bubble wrap or similar wrapping material. Protection caps must be fitted if supplied.

7.2 LONG TERM STORAGE

The connectors must be stored in a clean dry area and be protected by bubble wrap or similar. Suitable protection caps must be fitted (instrumentation connectors require sealed caps), and the storage temperature should be between -40°C and 70°C (Project Specific Connectors storage Temperature may vary). Humidity of the store room should be below 75%. Very moist or very dry conditions should be avoided. The Plug connector should be protected from strong sunlight and strong artificial light with a high ultra violet content. Moulded connectors should be placed within black bags to avoid direct sunlight. The connectors should not be allowed to come into contact with solvents, oil, greases or any other semi-solid materials. If glanded connectors are to be stored bolted into their interfaces ensure the cable entry point into the gland is covered to prevent water ingress.

8. DEPLOYMENT & MAINTENANCE

The following section details deployment and maintenance instructions for SpecTRON 5 connectors & hose.

All information contained within this section is generic. Where customer or project-specific information is required, please refer to the relevant project specification or scope of supply.

NOTE: IT IS IMPORTANT TO ISOLATE AND EARTH PRIOR TO DISCONNECT IN ORDER TO REMOVE ANY STRAY CHARGES IN THE SYSTEM. IF LEFT, THIS CAN INDUCE CORROSION ON THE EXPOSED PINS ONCE THE PLUG IS REMOVED.

8.1 SpecTRON 5



Figure 9 – SpecTRON 5 Power Connectors.

8.1.1 General SpecTRON

The SpecTRON 5 range of Power connectors has been developed for long term reliable high power control system applications associated with offshore installations. The underwater mateable capacity of these connectors is achieved using pressure compensated electrical inserts employing the CE principle.

Connectors are usually supplied with protective caps. The protective caps must be removed prior to mating the connectors. Refer to section 6.1 for instructions for removal of protective caps.

All mild steel sealing interfaces shall be inlaid with Inconel 625, or similar, where no additional protection (e.g. CP, Paint etc.) can be provided. This is to prevent localised pitting of the interface.

If the connectors are to be left unmated, in seawater, for any length of time dummy connectors must be used to protect the pin contacts in the receptacle connectors. Over exposure will increase the risk of corrosion damage or marine growth on the contact surfaces of the receptacle contact pins. This could lead to damage to the seals and insulation within the socket contacts.

Plug connectors may be left unmated, in seawater, for an indefinite period of time. However it is recommended that the Plug connectors are mated into a Parking Receptacle during this time in order to protect the socket contacts and latching mechanism.

It is good practice to always fit the protective cap when a connector is unmated topside prior to deployment to provide mechanical protection.

NOTE: 28 DAYS IS THE MAXIMUM CUMMULATIVE ALLOWABLE EXPOSURE OF UNPROTECTED CONTACT PINS (RECEPTACLE CONECTORS ONLY) TO SEAWATER OVER THE LIFE OF THE CONNECTOR. THIS ONLY APPLIES WITH POWER OFF.

The appropriate test connector must always be used to make electrical contact during testing. **UNDER NO CIRCUMSTANCES** should a foreign object (such as a screwdriver, test probe, or crocodile clip) be used as a test connection as this could damage the seals and insulation. Such actions will invalidate the warranty of the connector.

Guide pins must never be removed from test connectors as this can lead to damage and will invalidate the connector warranty.

NOTE: UNDER NO CIRCUMSTANCES MUST CONNECTORS BE DEMATED WHILST LIVE. NEITHER SHOULD CONNECTORS BE PARTIALLY MATED AND POWER APPLIED.

Refer to project specific data sheets and scope of supply drawings for performance specifications and detailed deployment instructions.

NOTE: NO PART OF THE CONNECTORS SHOULD BE DISMANTLED PRIOR TO OR DURING DEPLOYMENT, APART FROM THE REMOVAL OF PROTECTIVE CAPS, SINCE THERE ARE NO USER SERVICEABLE PARTS INSIDE.

8.1.2 Protection of Receptacle Contact Pins

Under no circumstances must the contact pins in the receptacle connector be exposed to seawater with power on. If this situation does occur the contact surfaces of the pins will very rapidly degrade by electrolytic action. If these damaged pins are subsequently mated into a socket insert there is a very high risk of damage to the insulation and seals within the plug connector.

8.1.3 Over current Capacity

Over current capacity varies for each product. Please refer to the product datasheet.

8.1.4 Removal of Marine Growth and Calcareous Deposits

To remove calcite growth from Siemens Subsea connectors, a solution of 50% Citric Acid is recommended. All Seawater exposed elastomeric materials in Siemens Subsea connectors have been fully tested against 50% Citric Acid and are compatible for a duration of 1 hour. In addition, the thermoplastic materials have good resistance to Citric Acid.

Other acid cleaners, such as 50% Acetic Acid, should not be used as they may cause deterioration of the elastomeric materials.

Chiselling and abrasive methods are not recommended. Wiping with a soft, clean cloth is acceptable providing care is taken inside the Receptacle shroud to avoid disturbing the earth continuity contact (i.e., Multilam or Bal spring type), or to impart a bending load on the power pin/s. Use of water jetting for the removal of sand/silt is acceptable given the following limitations:

- All forms of water jet cleaning of connectors in air must be avoided. The likelihood of damage to connectors is great, given the high localised impact velocities of the water jet.
- Submerged water jet cleaning of connectors is acceptable, providing the critical areas identified in Figure 10 are avoided. Particularly, the jet should not be directed at the Plug shuttle pins as this could result in a risk of water being forced through the primary seals and/or front seal. Remaining areas indicated below are suitable for submerged water jet cleaning.

*The water jet should not be directed into the mouth of the Receptacle shroud if the connector is fitted with an earth continuity contact (i.e. Multilam or Bal spring) as this could be displaced.

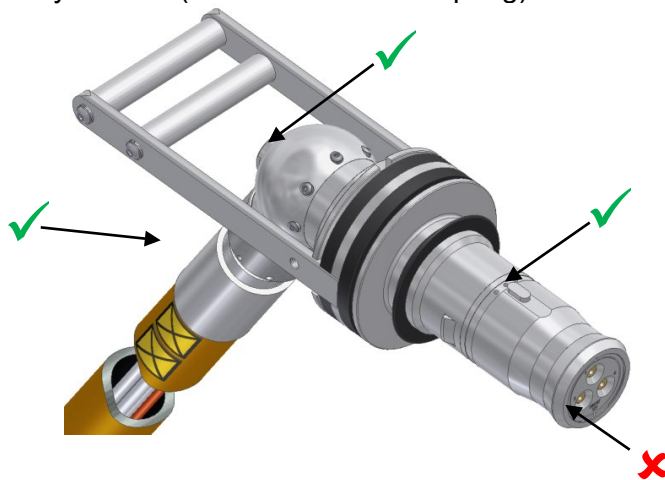

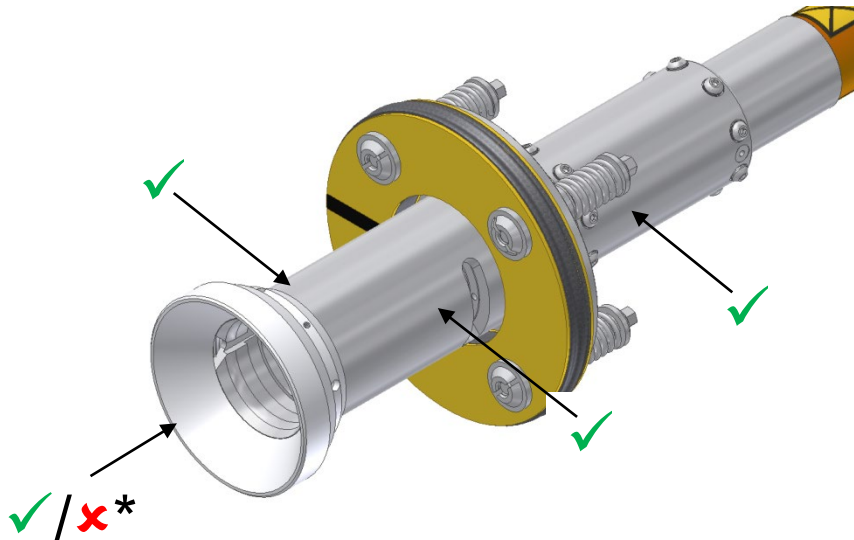

Figure 10 – Connector power washing precautions.

8.1.5 Stab Plate Connectors

- **Compliance**

One half of a stab mate connector pair must be allowed to float so that misalignment tolerances can be accommodated.

- **Mate/De-Mate Speed**

The connectors have been designed to operate across a wide range of mate / de-mate speeds with POWER OFF. There is no practical limit to the speed at which the connectors maybe mated or de-mated, however as a guide:

- a) Mating speed should not exceed 1 m/s.
- b) De-mating speed should not exceed 5 m/s

- **Pre-Mating Checks**

Before mating, the receptacle connector should be checked for debris. The connectors have been designed to accommodate sand and silt contamination, however large pieces of debris should be removed using a water jet.

- **Partial Disconnection**

Partial disconnection with the contact pin remaining between the primary and secondary diaphragms is not recommended. In this condition the level of insulation between the contact pin and socket contact is reduced and the connector is relying on the primary seals within the plug. There is also an increased risk of insulation break down at increased voltages.

- **Interrupted Connection**

Interrupted connection (i.e. Partial mate to full de-mate) can be carried out without any adverse affect to connectors, as long as the power is off.

- **Cathodic Protection:**

Stainless steel 316L (UNS S31603) connectors must be connected to the CP (Cathodic Protection) system at all times. Super Duplex stainless steel (UNS S32550) connectors should be isolated from the CP system to reduce the possibility of hydrogen embrittlement.

8.1.6 ROV Connectors

- **Alignment and Mating Technique**

These connectors have been designed to self align during mating. The connectors must be roughly aligned using the alignment marks on the connector body / alignment flange. The compliance within the connector handle, and the mating half, has sufficient compliance to accommodate fine adjustments during the final approach prior to connector engagement. The mating stroke should be as close as possible to one smooth movement, i.e. avoid 'pumping'.

- **Pre Mating Checks**

Before mating, the receptacle connector should be checked for debris. The connectors have been designed to accommodate sand and silt contamination, however large.

- **Mechanical Forces & Misalignment During Mating / De-Mating**

If mate / demate forces, maximum misalignment or overstroking forces have been defined, these will be specified in the product datasheet or design input document.

- **De-Mating**

De-mating is achieved by a straight pull on the ROV handle sufficient to release the latching mechanism. **Do not pull on the gland or hose.**

- **Cathodic Protection**

ROV connectors are designed to operate isolated from the CP [Cathodic Protection] system. ROV connectors will not suffer damage by being connected to the CP system, however there will be a tendency for increased calcareous deposits on metal surfaces, and the possibility of hydrogen embrittlement.

- **Mating / De-Mating of ROV connectors by Operator**

Refer to Section 9.1 for procedure for operator mating of the ROV connectors.

- **Post-Mating checks**

Determining a correct mating of the connectors must be done by visual inspection only. A pull-check on the handle should never be made as this will release the latching mechanism causing the connectors to separate.

There are two types of mating indicator employed on the SpecTRON 5 ROV connectors. Refer to connector datasheet or outline drawing in the documentation pack to determine which connector type you have. The connectors are fundamentally the same, employing the same CE principle. The main difference is that they have differing mating indicators as shown in the following figures.

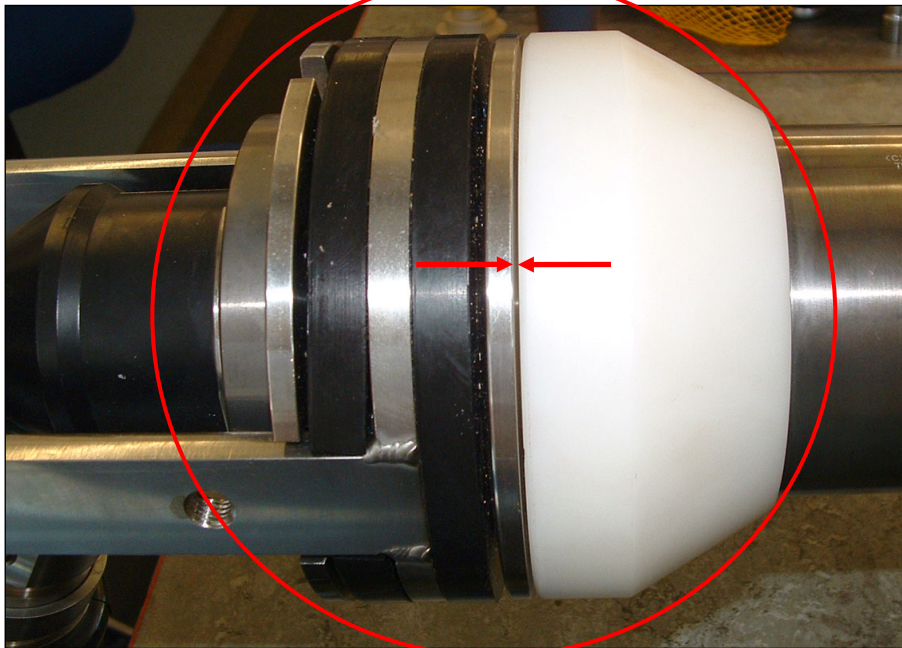
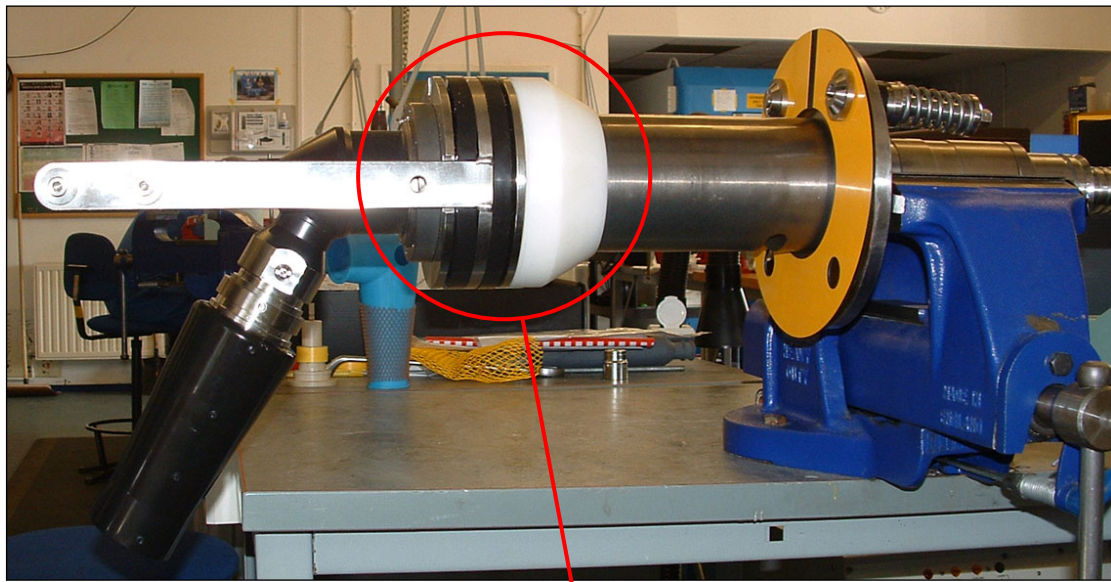

Figure 11 – Type 1 Mating check - Connectors fully mated. Note small gap between flanges.

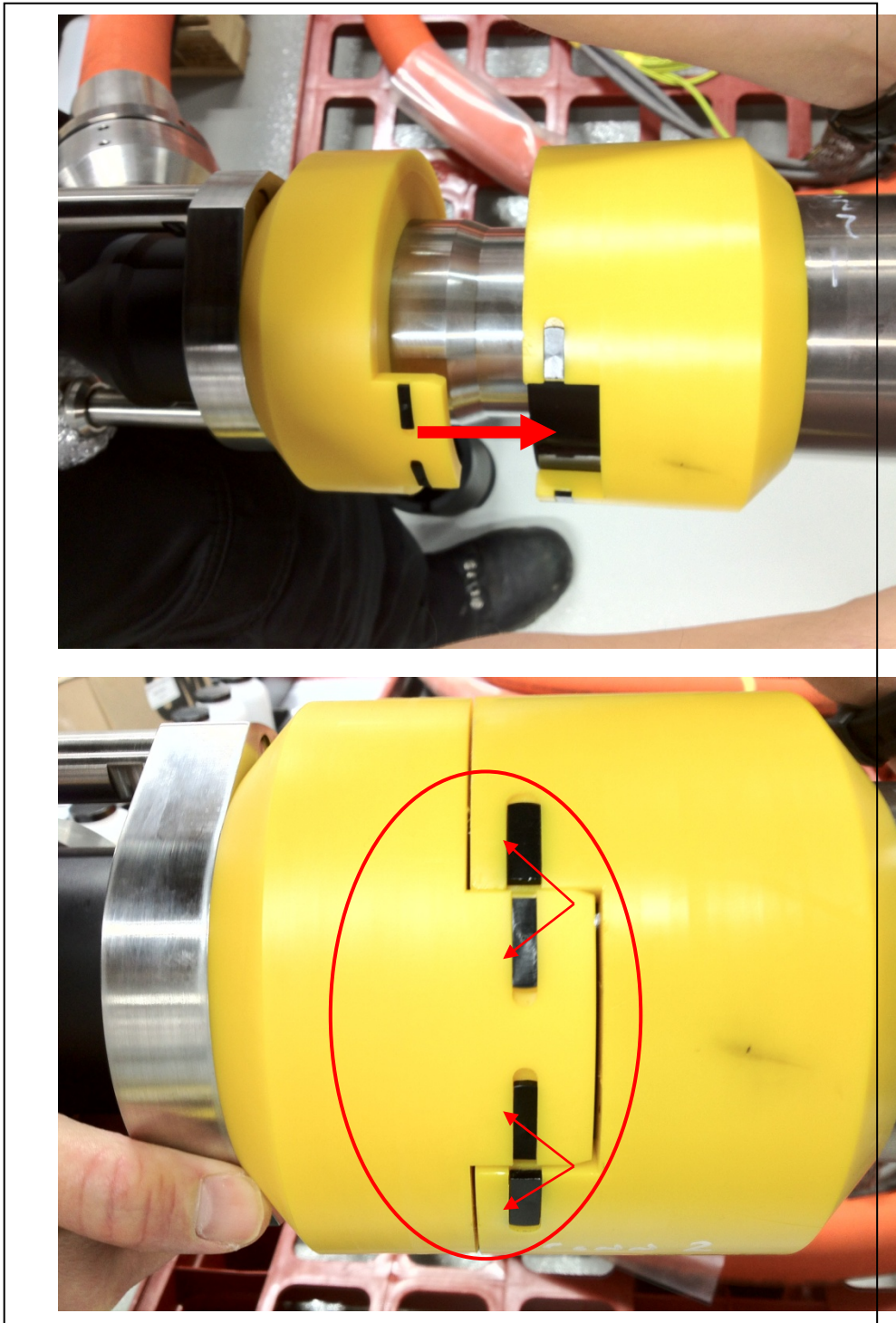

Figure 12 – Type 2 Mating check - Connectors fully mated. Note alignment of black markers on Plug & Receptacle. The thinner marker of the Plug should fall within the wider marker on the Receptacle Cone.

9. MANUALLY MATING/ DE-MATING ROV CONNECTORS

This section summarises the procedure that a diver would need to follow in order to mate/de-mate the ROV connectors manually (as opposed to mating/de-mating using an ROV).

9.1 MATING PROCEDURE

Prior to commencing the mating of the connector pair it is assumed that the Receptacle connector is mounted in its associated mounting plate, and that the Plug connector is in the near vicinity. Grab bars or other interfaces should be present on the Receptacle mounting structure, in order to provide the diver with purchase and allow him to address the connector square-on, with the connector at chest height.

1. Remove protective cap from Plug connector, or if Plug connector is mated to a Parking/Dummy Receptacle remove as detailed in De-Mating procedure below.
2. If a Dummy Plug connector is mated to the Receptacle, remove using the de-mating procedure detailed below.
3. Inspect Receptacle pins and shroud and ensure they are clean and free from debris, etc. If any debris is present remove using a water jet.
4. Show the Plug connector nose in to the shroud of Receptacle, and initially locate the key on the Plug nose into the slot of the Receptacle shroud, as shown below in Figure 13.

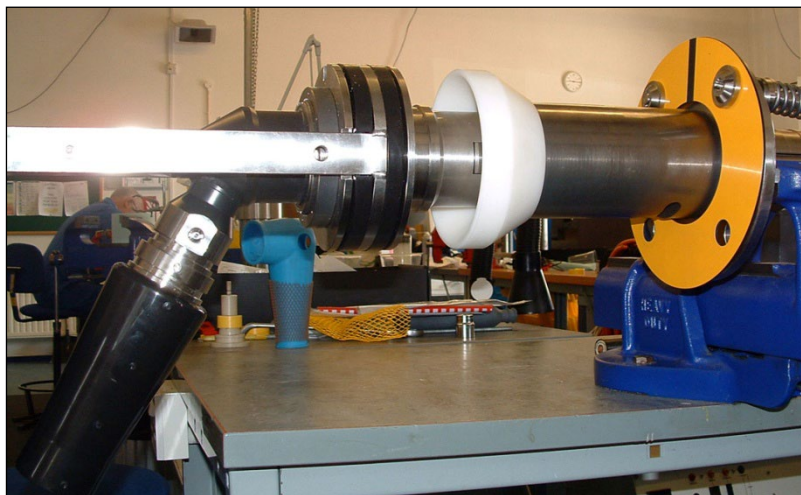

Figure 13 - Key on Plug locating in to slot in Receptacle.

- The operator should now get into a comfortable position, square on, ready to fully mate the connectors. In position, the connector should be at chest height, with grab bars or other provided interfaces on the mounting structure being within easy reach. Whilst using the grab bars or other mechanism to brace himself (i.e. tied to structure), the connector should be mated by holding the ROV handle on the back of the Plug connector (see Figure 14), and use *one smooth single stroke* to push the Plug connector along its axis until it butts up against the Receptacle. A force of 60kgf (588N) will be required to mate the connectors. Ensure the stroke is level, and the operator is able to complete the stroke in one smooth consistent movement. Also ensure that no bounce-back and failure to latch home has occurred. *When mated, under no circumstances should the Plug connector be pulled using the ROV handle to check it is correctly mated; this will de-mate the connector.* [When the plug connector end stops abut to the receptacle this activates a spring loaded latch, which stops the connectors de-mating. Pulling on the ROV Handle will de-activate this latch and hence will de-mate the connector.]

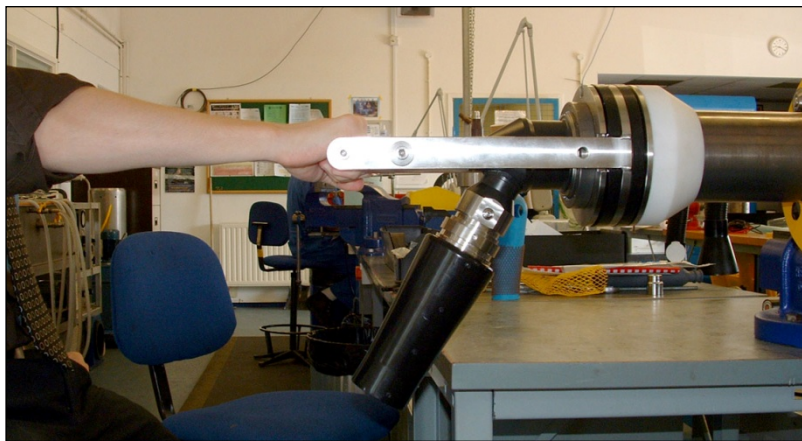

Figure 14 - Mate using ROV Handle
(DO NOT pull this handle to check if mated).

- To check if connectors are fully mated and Plug is correctly latched home, pull the Plug connector by holding the angled downward section of the plug body near to the hose termination (*DO NOT use the ROV handle*), as shown in Figure 15. If the connectors are correctly latched and mated no axial movement in the Plug connector should be present. As a visual inspection, the shoulder on the Plug should butt up against the shroud of the Receptacle. However, when relaxed there may be a *small* gap between the two (due to the springs in the Plug pushing against the Receptacle pins), as shown in Figure 16.

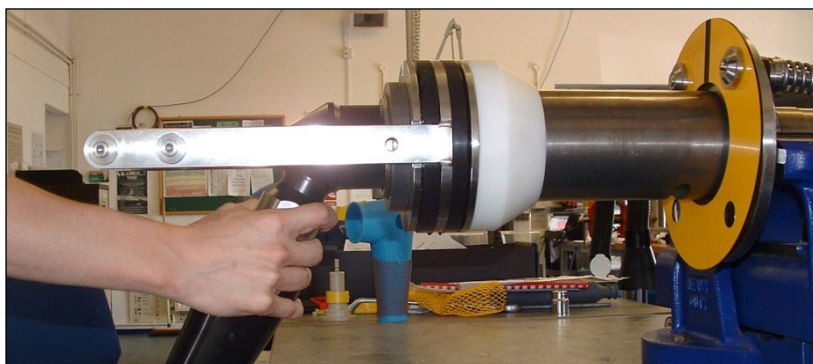

Figure 15 - Connectors mated. Pull angled downward section of body to check if Plug is correctly latched home.

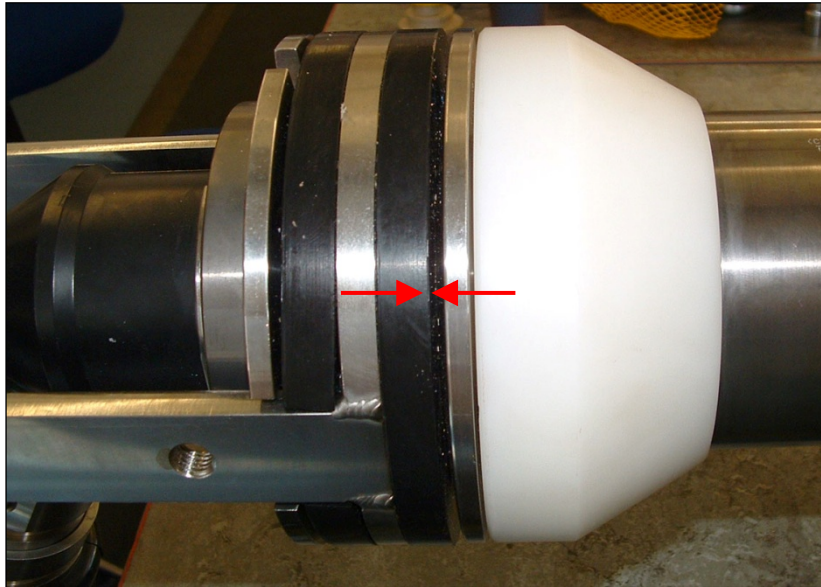

Figure 16 - Connectors fully mated.

Note small gap between flanges when fully mated.

9.2 DE-MATING PROCEDURE

Prior to commencing the de-mating of the connector pair it is assumed that the Receptacle connector is mounted in its associated structure, and a Plug connector is mated to it.

1. The operator should brace himself using the grab bars or other provided interfaces, and ensure the connector is at chest height.
2. By gripping the ROV handle (as shown in Figure 14), the connector should be de-mated from the Receptacle using one smooth pulling movement along the axes of the connectors. A force of 40kgf (392N) will be required to de-mate the connectors.
Note; the connector latch is automatically depressed by pulling the ROV handle.
3. When the Plug connector is fully separated from the receptacle connector, if appropriate it can then be mated to the parking Receptacle, using the steps mentioned in the mating procedure above. A dummy plug should also be mated to the remaining receptacle, again using the procedure above.

10. INSTALLATION

10.1 CONNECTOR & PENETRATOR INSTALLATION

It is recommended that the installation of all SpecTRON Penetrators and Mounted Connectors is undertaken by Siemens Subsea site engineers or trained personnel.

10.2 HOSE MANAGEMENT, ROUTING AND SUPPORT

Hose should be routed in a manner to avoid bending beyond the MBR or kinking of the hose (refer to section 3.3 for Minimum Bend Radius of Hose). The weight of hose in air will vary from that in water (refer to section 3.3 for weights in air and water). Although in water the hose is practically buoyant (<1kg/m), topside the weights can be significant and efforts should be made to avoid application of excessive weight to avoid exceeding the MBR or causing kinking.



Figure 17-MBR being maintained (AquaTRON 200 Hose)



Figure 18- MBR being maintained (Gorilla 1.5" Hose)

The hose will have some natural resistance to bending/ kinking however application of snag force due to unsuitable routing (ignoring hose MBR) or application of force due to unsupported hose weight may cause damage to the conductors or terminations and efforts should be made to avoid this during all applications topside or in water



Figure 19-Incorrect routing (hose deformed over “sharp” edge- AquaTRON 200 Hose)



Figure 20-Incorrect routing (hose deformed over “sharp” edge- Gorilla 1.5” Hose)

Particular efforts should be made to support the hose where it exits the rear of the connector, particularly if the hose is to be routed immediately in an orientation contradictory to the connector (e.g. immediate U shape routing – see Figures below)



Figure 21-Immediate U shape routing

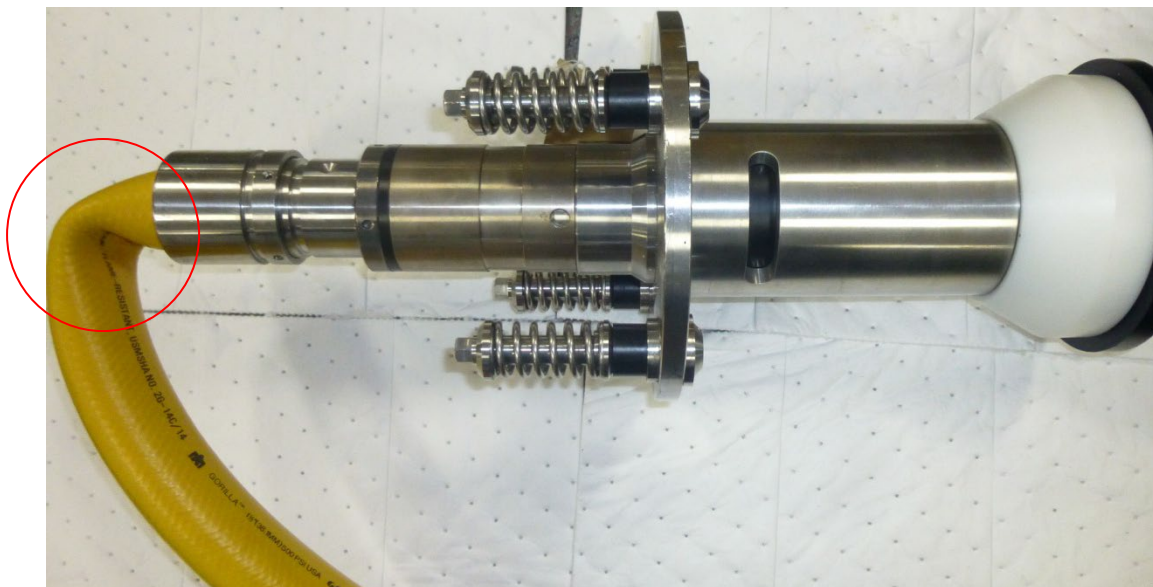

Figure 22-Hose kink due to acute angle and weight application

Siemens recommends the use of “formers” to avoid exceeding the MBR of the hose when exiting the connector or passing over acute angled surfaces (through or around structures).

10.2.1 FORMERS

Detailed below are some recommended shapes of former that may be utilised to aid routing of hose during SIT or structure routing (deployment).

Recommended Former Design

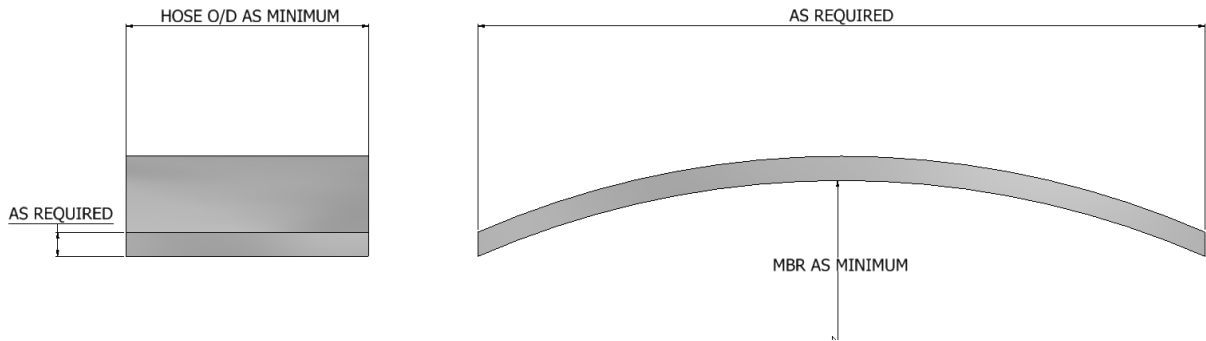

Figure 23- Plate Former

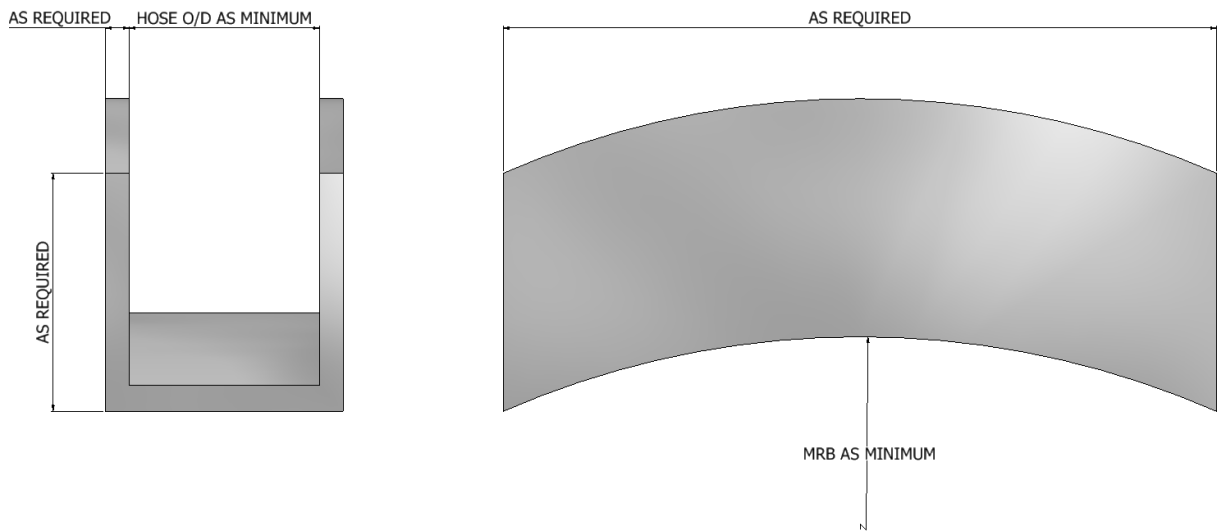

Figure 24- 'U' Former

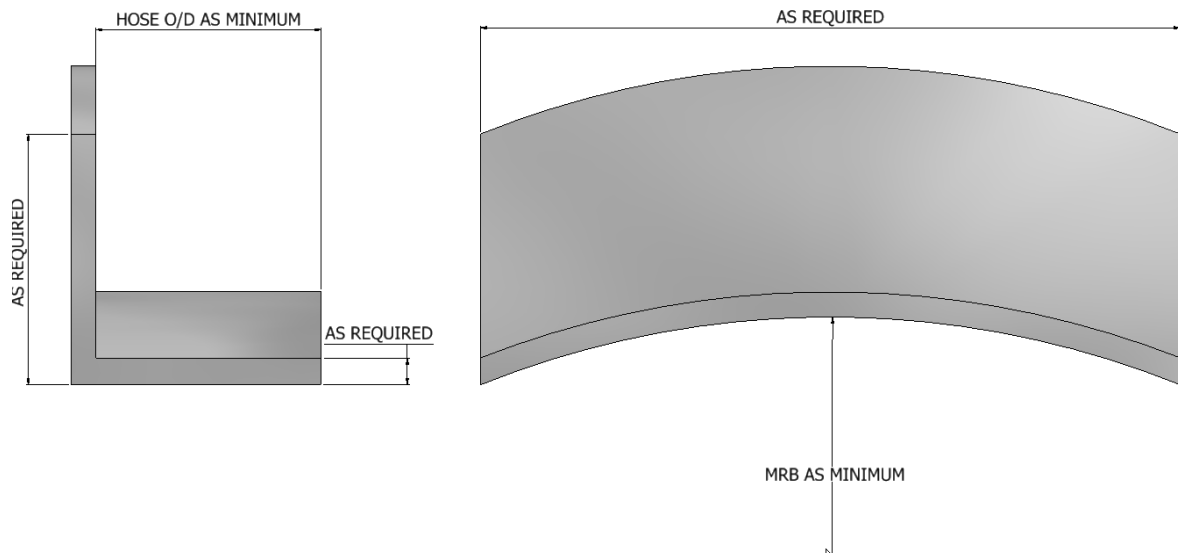

Figure 25- 'L' Former

10.2.2 FIXED INSTALLATIONS

Hose management should be considered in fixed installations, where more permanent solutions are acceptable.

Routing

To aid routing of hose within MBR and support free hanging hose greater than 5m, formers can be produced to Siemens recommended design (See section 10.2.1) or to client specific design, and permanently fixed to the client's structure via welding or bolt pattern.

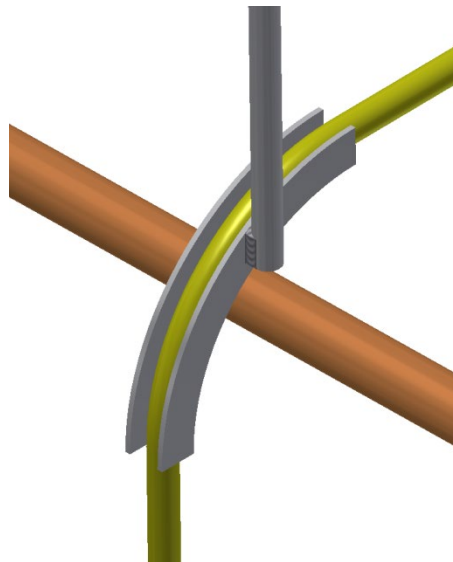

Figure 26-Permanent fixed 'U' former

Clamping

Siemens Subsea recommends that rubber inlaid plastic clamps are used to secure the hose (such as a Stauff pipe clamps with the correct inside diameter, refer to section 3.3 for hose diameters). Careful consideration should be given to the placement of the first clamp on a compliant mount connector so as not to restrict the compliancy of the connector or impart stresses into the hose and cable. Where clamping is required on compliantly mounted connectors, it is recommended that an 'S' type arrangement or similar as shown in Figure 27 is utilised to take up the potential movement of the connector.

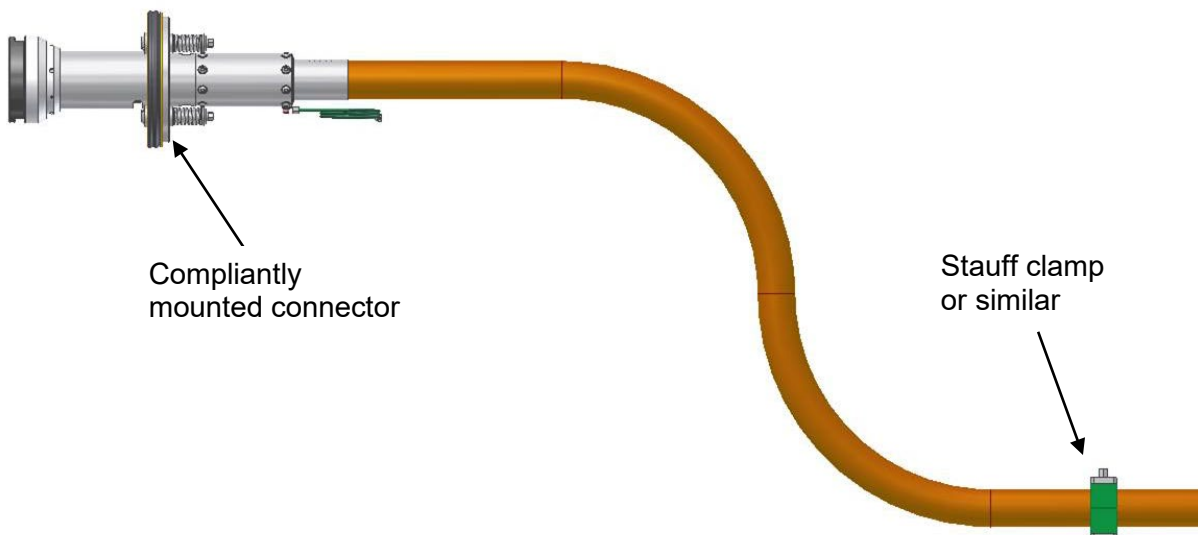

Figure 27 – Potential clamping of hose on compliant connector

10.2.3 Dynamic Installations (SIT layouts)

To aid the support of hose during SIT testing, formers can be produced to Siemens recommended design (See section 10.2.1) or to client specific design, and temporarily fixed to the client's structures via the use of tie wraps or clamps.

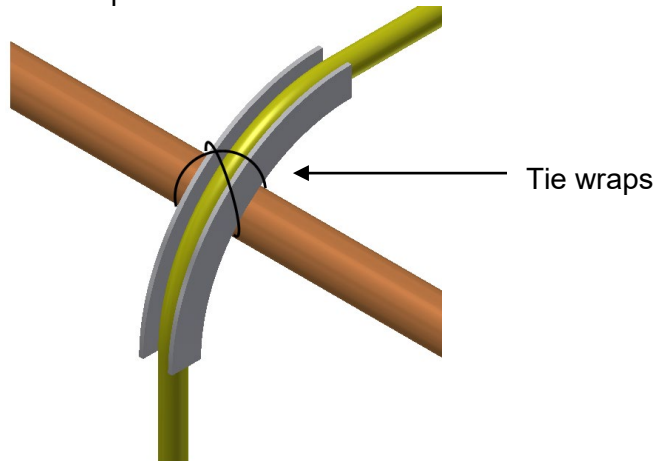

Figure 28

The maximum recommended length of hose which can be unsupported is 5 meters, however the MBR of the hose must still be observed at the hose exit of a connector before allowing 5m of hose to hang freely.

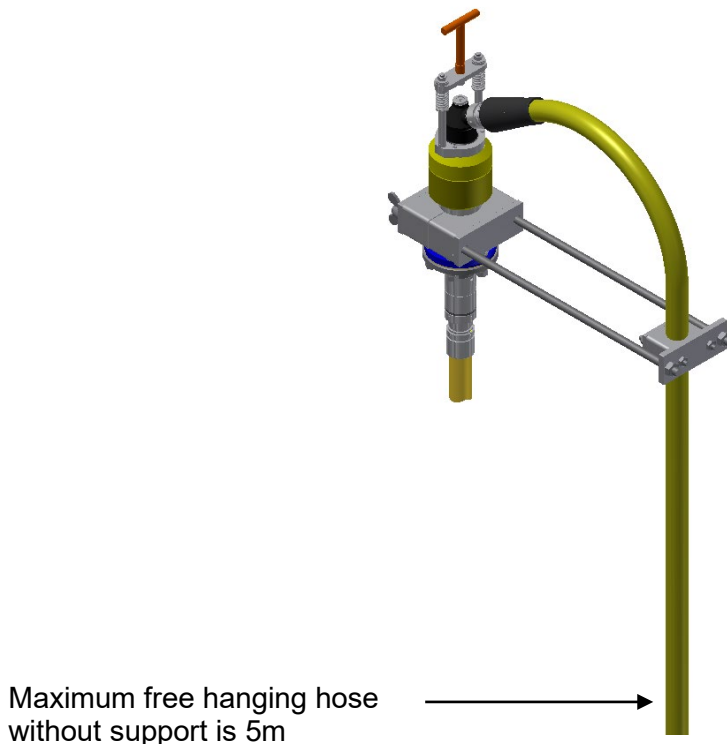

Figure 29

Figure 29 shows an example of a vertically mounted plug and receptacle with correct hose routing. The image shows how the hose may be self supported by the use of Stauff clamps mounted to the connector body. If a system similar to Figure 29 is to be employed then Siemens Technical must be consulted to assess the impact on the connectors and their terminations.

During SIT the hose termination has significant weight (refer to section 3.3 for hose weights) and efforts should be made to avoid hanging of this weight from the connector termination itself. This could also be combated by providing a temporary elevated floor for SIT via the use equipment such as scaffolding, scissor lifts and ladders etc or alternatively a fabricated stand with a former attached. See Figure 30.

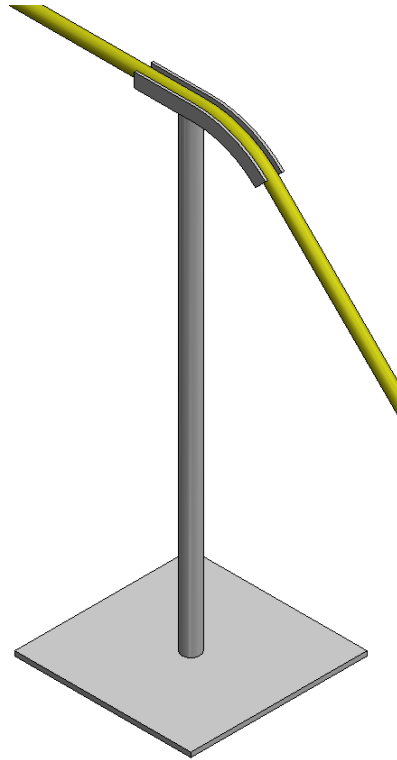

Figure 30- fabricated stand with former used for hose support

