

# SIEMENS

*Ingenuity for life*



## Breaker Pole Discrepancy Function

# SIPROTEC 5 Application

## Breaker Pole Discrepancy Function

---

# SIPROTEC 5 Application

## Breaker Pole Discrepancy Function

APN-031, Edition 2

### Content

1	Breaker Pole Discrepancy Function .....	3
1.1	Introduction.....	3
1.2	Overview .....	3
1.3	Circuit breaker switching state.....	3
1.4	Pole discrepancy signal.....	5
1.5	CFC Logic.....	6
1.6	Timer Setting.....	6
1.7	Logic with Phase Selective Close AND Open .....	7
1.8	Conclusion.....	8

# 1 Breaker Pole Discrepancy Function

## 1.1 Introduction

This application note describes a simple method to obtain a breaker pole discrepancy alarm using SIPROTEC 5.

Additionally, the SIPROTEC 5 device manuals as well the DIGSI 5 help function should be consulted for further details.

## 1.2 Overview

In most circuit breaker applications, the pole discrepancy function is part of the circuit breaker. Where breakers can be tripped single pole, the protection and auto re-close function ensure that a circuit breaker never ends in a single pole open state. Some applications however demand a circuit breaker pole discrepancy function in the protection relay. Such a pole discrepancy function is based purely on the status of the auxiliary contacts. This application note describes how this can be implemented with SIPROTEC 5 using standard functions included in the device.

## 1.3 Circuit breaker switching state

The breaker switching state is obtained via binary inputs. There are a number of alternatives for the application of the auxiliary contacts:











▼  Circuit break.	301.4261		*	*	*	*
▶  >Ready	301.4261.500	SPS				
▶  >Acquisition blocking	301.4261.501	SPS				
▶  >Reset switch statist.	301.4261.502	SPS				
▶  External health	301.4261.503	ENS				
▶  Health	301.4261.53	ENS				
▶  Position 3-pole	301.4261.58	DPC	OH			
▶  Position 1-pole phsA	301.4261.459	DPC		CH		
▶  Position 1-pole phsB	301.4261.460	DPC			CH	
▶  Position 1-pole phsC	301.4261.461	DPC				CH

Figure 1: Typical routing of binary inputs for circuit breaker auxiliary contacts

With the routing shown in Figure 1 above, the circuit breaker auxiliary contacts can, with good reliability, indicate both the open and closed state of the circuit breaker. For this example the external connection shown in Figure 2 below is required. For the application of the pole discrepancy function as described in this document, the 3 phase selective auxiliary contact signals, Position 1-pole phsX, must be applied in the closed high (CH) configuration because the logic will evaluate the phase selective CLOSED-Status. The 3-phase status, for example the Position 3-pole, which is routed as "OH" in Figure 1, is not required and may be left out.

Under Heading "1.7 Logic with Phase Selective Close AND Open" a further variant for the Pole Discrepancy Function is provided. This requires 6 binary inputs and replicates the classic discrete logic.

# SIPROTEC 5 Applikation

## Breaker Pole Discrepancy Function

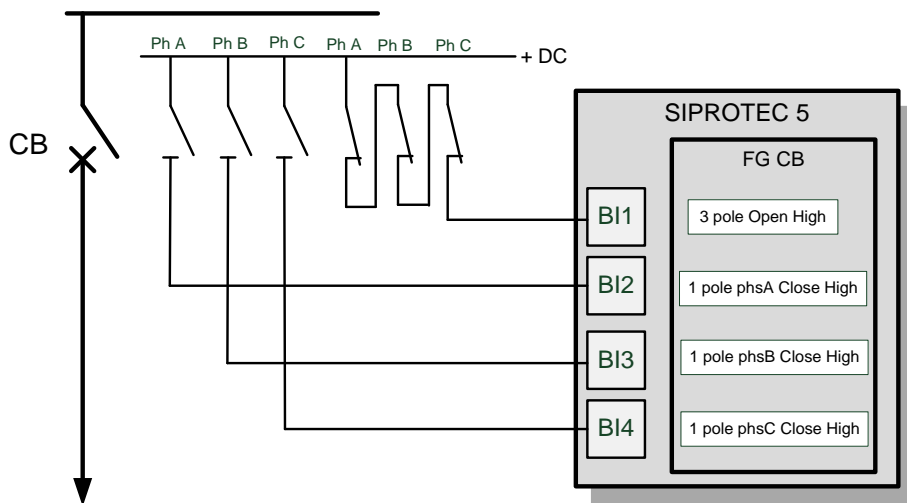

Figure 2: Connection of auxiliary contacts – with phase selective Close High status

The following state indications are available for the Circuit Breaker.

Signals	Number	Type	1
(All)	(All)	...	
▼ Circuit break.	301.4261		
◆ >Ready	301.4261.500	SPS	
◆ >Acquisition blocking	301.4261.501	SPS	
◆ >Reset switch statist.	301.4261.502	SPS	
▶ ◆ External health	301.4261.503	ENS	
▶ ◆ Health	301.4261.53	ENS	
▶ ◆ Position 3-pole	301.4261.58	DPC	
▼ ◆ Position 1-pole phsA	301.4261.459	DPC	
◆ open		SPS	
◆ closed		SPS	
◆ intermediate position		SPS	
◆ disturbed position		SPS	
▶ ◆ Position 1-pole phsB	301.4261.460	DPC	
▶ ◆ Position 1-pole phsC	301.4261.461	DPC	

Figure 3: Indication of circuit breaker state (the phase selective closed state is used in the logic)

The signals that will be used for the pole discrepancy function are the phase selective closed state. In Figure 3 above this is the highlighted "Position 1-pole phsA/closed" for phase A. These states are indicated as soon as the state of the auxiliary contact for the respective phase shows that the pole is closed or not open.

### 1.4 Pole discrepancy signal

A user defined signal and time delay must be introduced for this purpose. From the library first add the “Chart Setting Integer” and rename it to “Pole Disc, Timer ms”. In the next step drag and drop the SPS into the new function and rename it “PD alarm”.

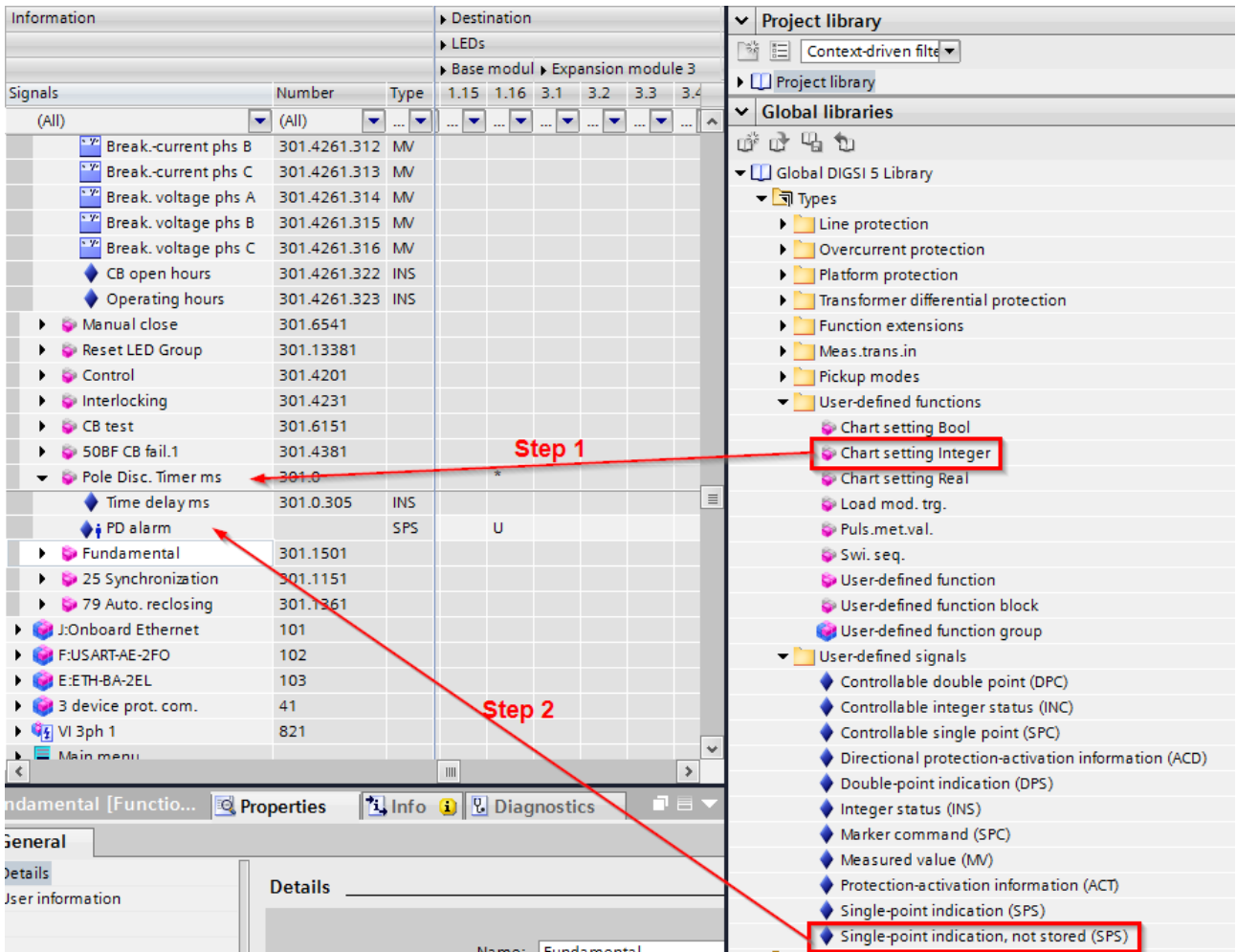

Figure 4: Add user defined objects

The new signal “PD alarm” is the pole discrepancy alarm. It may be routed to the required destinations now or later.

# SIPROTEC 5 Applikation

## Breaker Pole Discrepancy Function

### 1.5 CFC Logic

For the pole discrepancy alarm the following logic is applied via a CFC chart. The chart is applied as "Event Triggered CFC":

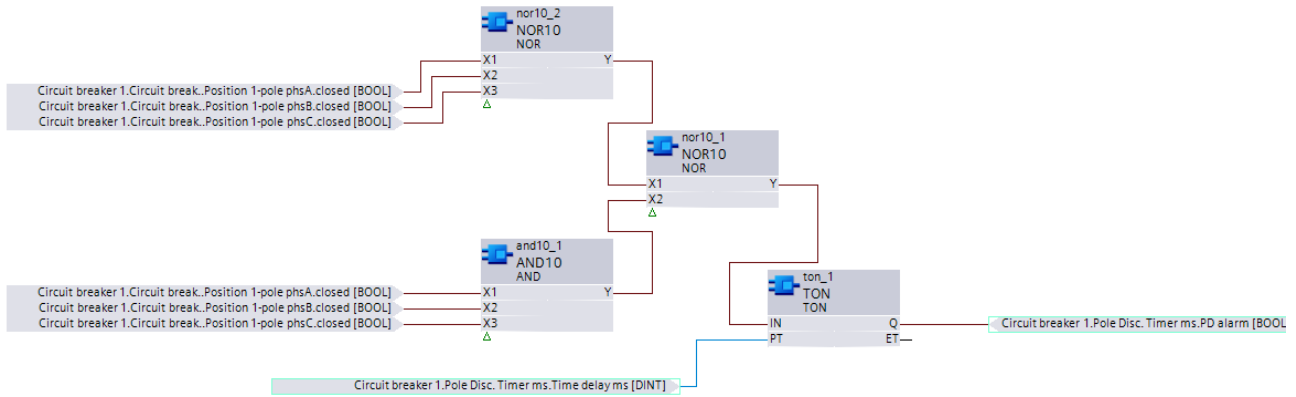

Figure 5: CFC chart with pole discrepancy logic (Phase Selective Closed Status)

The input to the timer will only be a high state when both the 3 input NOR gate and AND gate have a "zero" at their outputs. This happens when the Closed State is not the same in all three phases. Based on the three inputs used for the phase selective status as shown in Figure 2, this is the pole discrepancy state that will be alarmed when the set time expires.

### 1.6 Timer Setting

The pole discrepancy time is set in "ms" in the user defined chart setting timer applied under heading 1.4 above. A setting of 1200 ms is applied as shown in the screen shot below:

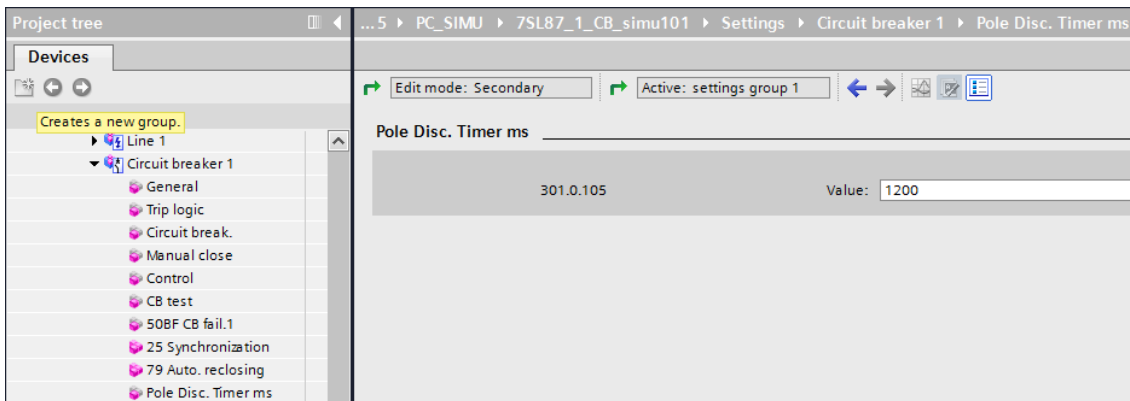

Figure 6: Setting of pole discrepancy timer

### 1.7 Logic with Phase Selective Close AND Open

The classic pole discrepancy function was implemented using 6 breaker auxiliary contacts in the configuration shown in Figure 7 below:

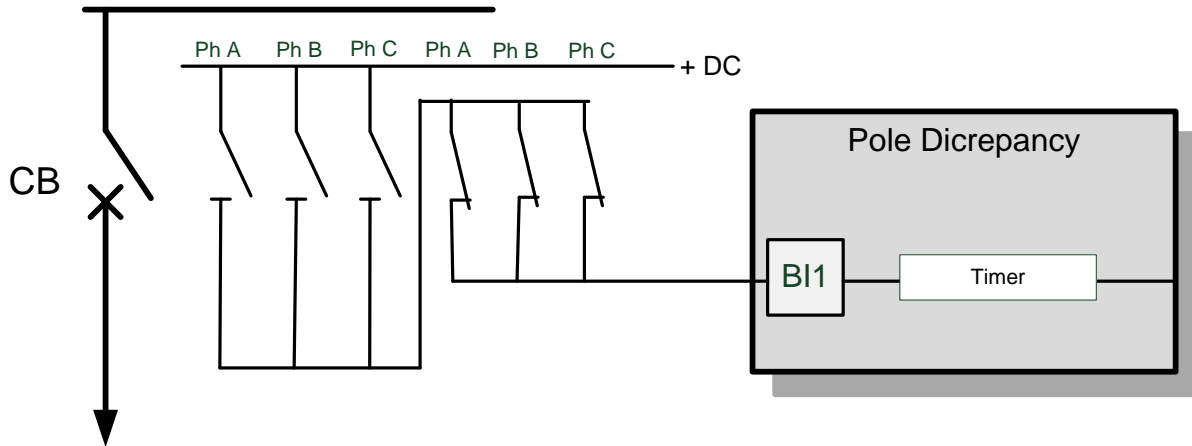

Figure 7: Typical connection of discrete Pole Discrepancy Logic

If the 6 auxiliary contacts shown in Figure 7 are connected to the SIPROTEC5 device a different logic should be implemented to achieve the same response as from the discrete logic shown in Figure 7 (Figure 9).

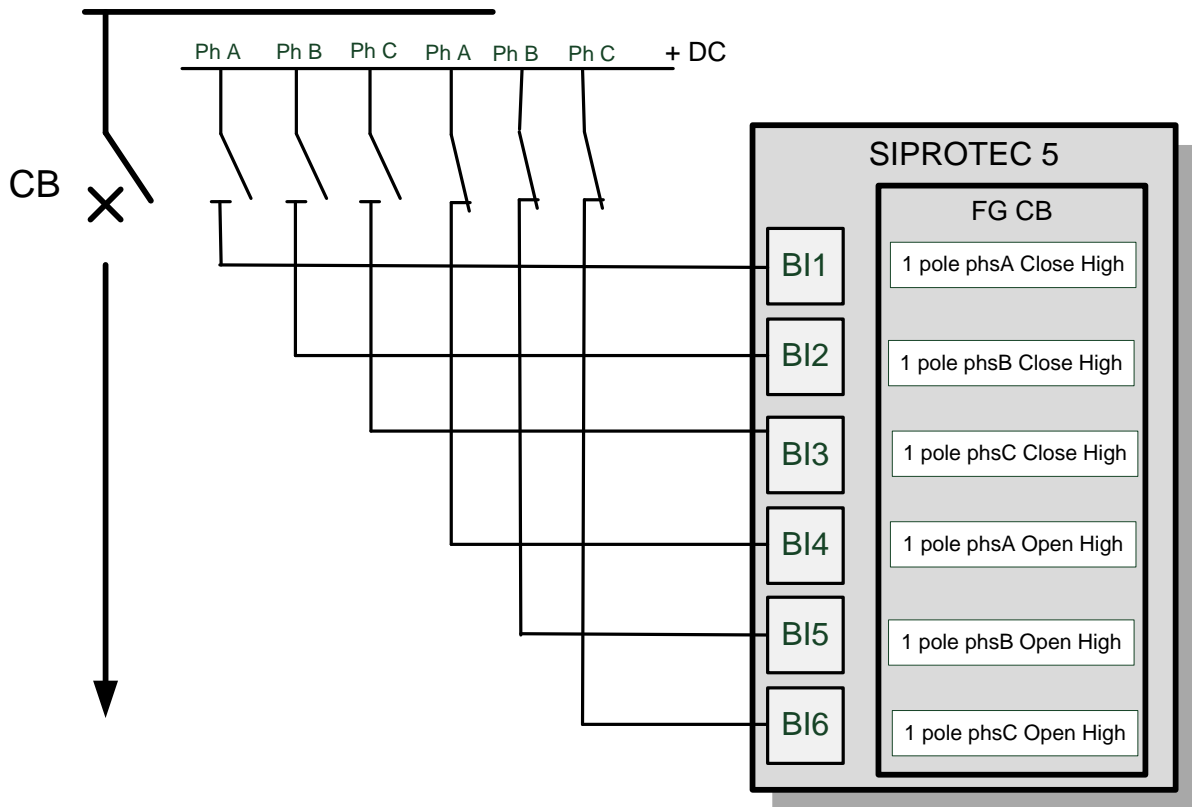

Figure 8: Connection of auxiliary contacts – with phase selective Close High AND Open High status

To replicate the pole discrepancy logic as shown in Figure 7 with the connection to SIPROTEC5 as shown in Figure 8 the following logic must be applied:

# SIPROTEC 5 Applikation

## Breaker Pole Discrepancy Function

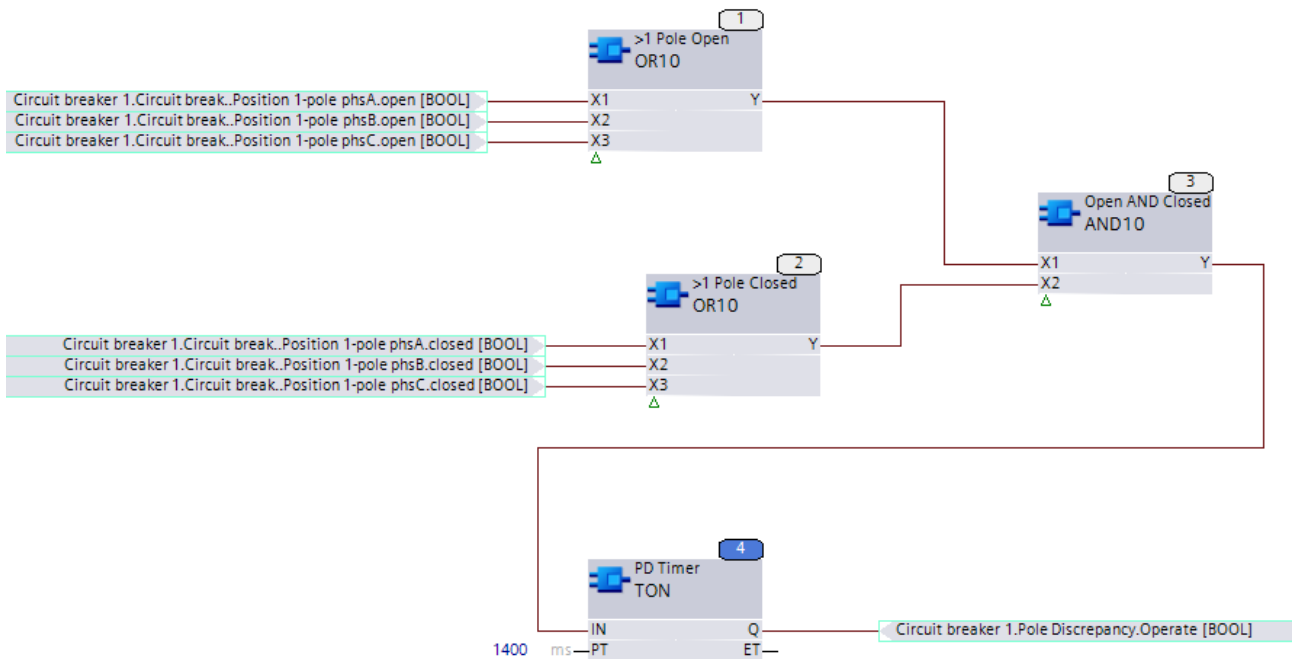

Figure 9: CFC chart with pole discrepancy logic (Phase Selective Closed AND Open Status)

With the CFC chart in Figure 9, the output of the two 3-input OR gates will both be high only when at least one of the normally open and one of the normally closed auxiliary contacts is closed (compare with Figure 7). The AND gate will then only trigger the timer when this pole discrepancy condition is present.

## 1.8 Conclusion

The application note shows how the standard functions in the device can be applied to derive additional functions such as a Pole Discrepancy Alarm.

Note that the logic must be selected according to the manner in which the Breaker Status is obtained.



# SIPROTEC 5 Application

## Breaker Pole Discrepancy Function

---

Published by  
Siemens AG 2016  
Energy Management Division  
Digital Grid  
Automation Products  
Humboldtstr. 59  
90459 Nuremberg, Germany

[www.siemens.com/siprotec](http://www.siemens.com/siprotec)

For more information,  
please contact our  
Customer Support Center.

Tel.: +49 180 524 70 00

Fax: +49 180 524 24 71

(Charges depending on provider)

Email: [support.energy@siemens.com](mailto:support.energy@siemens.com)

© 2016 Siemens. Subject to changes and errors.  
The information given in this document only contains  
general descriptions and/or performance features which  
may not always specifically reflect those described, or  
which may undergo modification in the course of further  
development of the products. The requested performance  
features are binding only when they are expressly agreed  
upon in the concluded contract.

For all products using security features of OpenSSL, the  
following shall apply:  
This product includes software developed by the OpenSSL  
Project for use in the OpenSSL Toolkit.  
(<http://www.openssl.org/> )  
This product includes cryptographic software written by  
Eric Young (eay@cryptsoft.com )  
This product includes software written by Tim Hudson  
(tjh@cryptsoft.com)  
This product includes software developed by Bodo Moeller.