



Reyrolle
Protection
Devices

7SR242 Duobias

Transformer Protection Relay

Energy Management

SIEMENS

7SR242 Duobias

Transformer Protection Relay



Description

Our new generation of integrated transformer protection relays are designated the 7SR24 series. The relays utilise years of numeric relay protection experience with the 'Duobias' family of products. Housed in 4U high, size E8, E10 or E12 cases, these relays provide protection, control, monitoring, instrumentation and metering with integrated input and output logic, data logging & fault reports. Communication access to relay functionality is via a front USB port for local PC connection or rear electrical RS485 port for remote connection. Additional rear port options are available.

Function Overview

Standard Functionality

50BF	Circuit Breaker Fail
64H	High Impedance REF
74TCS/CCS	Trip/Close Circuit Supervision
81HBL2	Inrush Detector
81HBL5	Overfluxing Detector
87BD	Biased Differential (2Windings)
87HS	Current Differential High-Set
8 Settings Groups	
Password Protection – 2 levels	
User Programmable Logic Equations, via HMI	
Graphical Programmable Logic, via pc application	
Self Monitoring	

Optional Functionality

24	Over-Fluxing
27/59	Under/Over Voltage
37/37G	Undercurrent
46BC	Open Circuit
46NPS	Negative Phase Sequence Overcurrent
49	Thermal Overload
50	Instantaneous Overcurrent
50G/N	Instantaneous Earth Fault
51	Time Delayed Overcurrent
51G/N	Time Delayed Measured Earth Fault /SEF
59N	Neutral Voltage Displacement
81	Under/Over Frequency

User Interface

- 20 character x 4 line backlit LCD
- Menu navigation keys
- 3 fixed LEDs
- 16, 24 or 32 Programmable Tri-colour LEDs (Option)

Monitoring Functions

- Primary current phases and earth
- Secondary current phases and earth
- Relay Operate and restraint currents
- Positive Phase Sequence (PPS) Current
- Negative Phase Sequence (NPS) Current
- Zero Phase Sequence (ZPS) Current
- Thermal status
- Primary Single phase voltage*
- Secondary single phase voltage*
- Data logging and Demand Metering
- Frequency & fluxing*
- Binary Input/binary output and virtual I/O status
- Trip circuit healthy/failure
- Time and date
- Fault records
- Event records
- Waveform records
- Circuit breaker trip counters
- I²t summation for contact wear
- * Optional voltage measurements from single phase VT input

Data Communications

Standard

Communication access to relay functionality is via a front USB port for local PC connection or rear electrical RS485 port for remote connection

Optional

- 2 Rear ST fibre optic ports (2 x Tx/Rx) + IRIG-B port
- 1 Rear RS485 + IRIG-B port
- 1 Rear RS232 + IRIG-B port
- 2 rear electrical Ethernet RJ45 connectors
- 2 rear optical Ethernet duplex LC connectors

Protocols

IEC60870-5-103, Modbus RTU, and DNP 3.0 protocols. User selectable with programmable data points. Optional IEC61850 ethernet with user selectable RSTP, HSR & PRP operation.

Description of Functionality

50BF Circuit Breaker Fail

The circuit breaker fail function may be triggered from an internal trip signal or from a binary input. Line and neutral currents are monitored following a trip signal and an output is issued if any current is still detected after a specified time interval. Alternatively, if the trip is from a mechanical protection the circuit breaker position can be used to determine a failure. A second time delay is available to enable another stage to be utilized if required. An input is also available to bypass the time delays when the circuit breaker is known to be faulty.

64H Restricted Earth Fault - scheme

The measured earth fault input may be used in a high impedance restricted earth fault scheme. Required external series stabilising resistor and non-linear voltage limiting shunt resistor can be supplied.

74TCS/CCS Trip/Close Circuit Supervision

The trip and close circuit(s) can be monitored via binary inputs. Circuit failure raises an HMI alarm and output(s).

81HBL2 Inrush Detector

Where second harmonic current is detected (i.e. during transformer energisation) user selectable elements can be blocked.

81HBL5 Overfluxing Detector

Fifth Harmonic Detectors can be user selected to block the Biased Differential Elements.

87BD Biased Differential

The differential characteristic incorporates two bias stages – the first stage for steady state errors i.e. tap position and CT ratios the second stage for transient errors i.e. CT saturation.

87HS High-Set Differential

High speed differential elements provide protection against high levels of internal fault current.

Programmable Logic

The user can map Binary Inputs and Protection operated outputs to Function Inhibits, Logic Inputs, LEDs and/or Binary Outputs.

The user can also enter up to 16 equations defining scheme logic using standard functions e.g. Timers, Latches, AND/OR gates, Inverters and Counters.

Each Protection element output can be used for Alarm & Indication and/or tripping.

In addition, the Reydisp Manager PC application provides graphical programming of user logic within the device.

Circuit Breaker Maintenance

For each winding two circuit breaker operations counters are provided. The Maintenance Counter records the overall number of operations and the Delta Counter the number of operations since the last reset.

I²t summation Counters provide a measure of the contact wear indicating the total energy interrupted by the circuit breaker contacts.

Each counter has a user set target operations count which, when reached, can be mapped to raise Alarms/ Binary Outputs.

These counters assist with maintenance scheduling.

Function LED's

16 or 24 user programmable tri-colour LED's are provided eliminating the need for expensive panel mounted pilot lights and associated wiring. Each LED can be user set to red, green or yellow allowing for clear indication of the associated function's state. A slip-in label pocket along-side enables the user to insert his own notation. A printer compatible template is available.



Fig. 1: Tri-colour LED's

Optional Functionality

24 Over-Fluxing

Two elements each provide a definite time lag (DTL) characteristic, the third element provides a user defined characteristic. Operates if Volts/Hertz ratio is above setting for duration of delay.

27/59 Under/Over Voltage

Each element has settings for pickup level, drop-off level and Definite Time Lag (DTL) delays. Operates if voltage 'exceeds' setting for duration of delay.

This function can be used within load shedding schemes.

37/37G Undercurrent

Each element has settings for pickup level and Definite Time Lag (DTL) delays. Operates if current falls below setting for duration of delay.

46NPS Negative Phase Sequence Overcurrent

Two DTL and two inverse/DTL elements are provided. NPS Current elements can be used to detect unbalances on the system or remote earth faults when a delta-star transformer is in circuit.

46BC Open Circuit

Each element has settings for pickup level and DTL delay. With the circuit breaker closed, if the NPS:PPS current ratio is above setting this could be due to an open circuit.

49 Thermal Overload

The thermal algorithm calculates the thermal states from the measured line currents. Outputs are available for thermal overload and thermal capacity.

50/51 Phase Fault

50 INST/DTL and 51 IDMTL/DTL elements provide overcurrent protection, each with independent settings for pickup current, time-multiplier (51) and time-delays. IEC, ANSI or user defined Time Current Characteristics can be selected. The IDMT stage has a user programmable DTL or shaped current/time reset characteristic, to improve grading with electromechanical protection.

50G/51G/50N/51N Earth Fault

Two earth fault measurement modes are available. One mode directly measures the earth current from an independent CT, or the residual connection of the 3 line CTs (50G/51G). The second mode derives the earth current internally from the 3 phase CTs (50N/51N).

50 INST/DTL and 51 IDMTL/DTL elements provide overcurrent protection, each with independent settings for pickup current, time-multiplier (51) and time-delays. IEC, ANSI or user defined Time Current Characteristics can be selected.. The IDMT stage has a user programmable reset characteristic either DTL or shaped current/time reset characteristic to improve grading with electromechanical protection.

59N Neutral Overvoltage

One element provides a definite time lag (DTL) characteristic; the second element provides an inverse/DTL characteristic. Operates if Neutral voltage exceeds setting for duration of delay.

Neutral overvoltage can be used to detect earth faults in high impedance earthed or isolated systems.

81 Under/Overfrequency

Each element has settings for pickup level, drop-off level and Definite Time Lag (DTL) delays. Each element operates if frequency exceeds setting for duration of delay. Typically applied in load shedding schemes.

Data Acquisition - Via Communication Interface

Sequence of event records

Up to 5000 events are stored and time tagged to 1ms resolution.

Fault Records

Measured quantities for the last 100 relay trip fault records are stored with time and date of trip.

The HMI can display the last 10 fault records with time and date of trip, measured quantities and LED status.

Waveform recorder

The waveform recorder stores data for all analogue input values along with the states of protection functions, binary inputs/outputs and LEDs.

Waveform record storage can be triggered from operation of a user selected protection function, binary input or via data communications.

The duration of record storage is user configurable. 100 records of 1, 2, 5 or 10 seconds are stored. The ratio of pre-fault to post fault storage can be set by the user.

Demand Monitoring

A record of demand is available. The demand minimum, maximum and average values for currents, frequency and if applicable, voltages over a user selectable period of time is displayed and available via data communications. Typically this is set as a rolling value for the last 24 hours.

Data Log

Provides a rolling record of current and voltage (where applicable), recorded at a user selectable interval and stored to provide data in the form of a Data Log which can be downloaded for further analysis. A typical application is to record 15 minute intervals over the last 7 days.

Real Time Clock

The time and date can be set and are maintained while the relay is de-energised by a back up storage capacitor. The time can be synchronized from a binary input pulse, via the data communication channel(s) or from the optional IRIG-B port.

Serial Communications

The relay offers a USB serial port as standard on the front of all units. All of the relays functions can be set on a PC using Reydisp Evolution via the relay USB port. The connection is made with a USB cable and operates with a 'plug and play' connection, so no pre-setting of the relay is required.

The front port can be switched off or set to use either the MODBUS-RTU, IEC60870-5-103, DNP3.0 (optional) or ASCII protocols for testing purposes.

A rear RS485 electrical connection is available on all units for system interface connections. An internal terminating resistor is provided, which can be connected into the circuit by adding a wire loop between the relevant terminals.

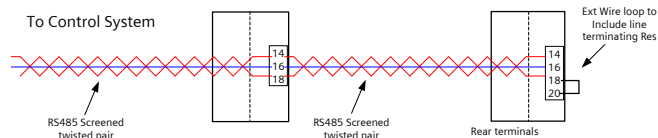

Fig. 2: Typical RS485 connection

The rear RS485 can be user selected to be OFF, IEC60870-5-103, MODBUS RTU or optional DNP3.0 protocol.

Reydisp Evolution

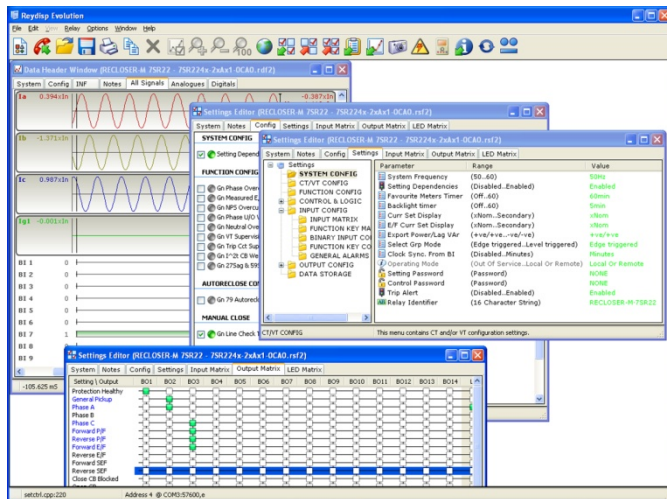

Fig. 3: Typical Reydisp Evolution screenshot

Reydisp Evolution is common to the entire range of Reyrolle numeric products. It provides the means for the user to apply settings interrogate settings and retrieve events and disturbance waveforms from the Duobias relay.

Reydisp Evolution installation includes the Communications Editor to allow configuration of the serial protocol data points and options, the Curve Editor to allow programming of user defined TCC characteristics and the Language Editor to allow relay display text to be edited. This can be used to provide non-English language support using the European character set.

Reydisp Manager

Reydisp Manager provides the functionality of Reydisp Evolution and also provides project management of multiple devices to allow engineering of IEC61850 projects. It also provides access to user logic within the devices via an easy to use graphical interface.

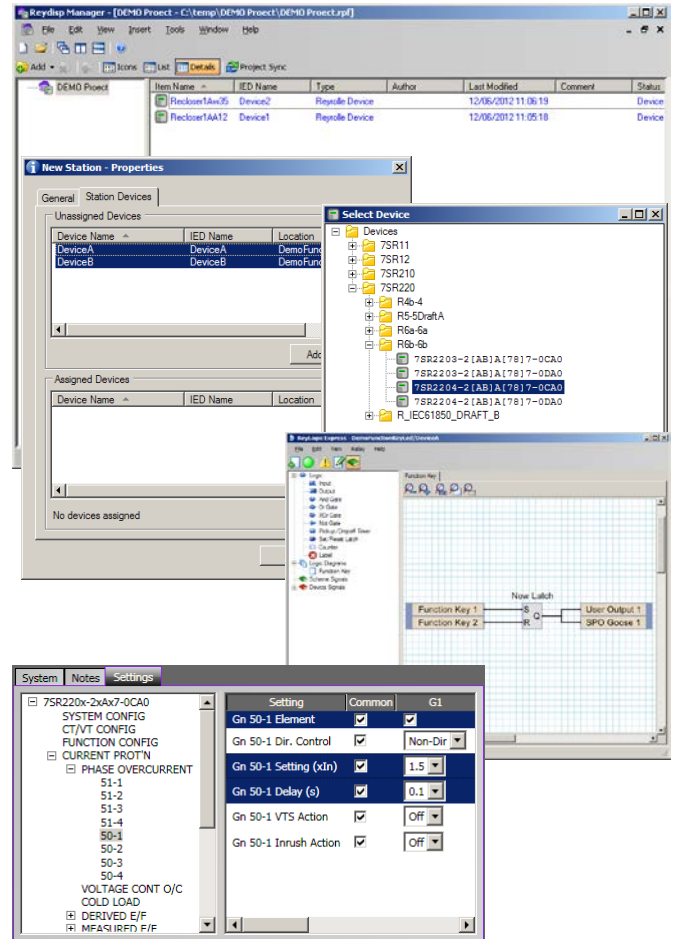

Fig. 4: Typical Reydisp Manager screenshot

Technical Data

For full technical data refer to the Performance Specification Chapter of the Technical Manual.

Allowable superimposed ac component	≤ 12% of dc voltage
Allowable breaks/dips in supply (collapse to zero from nominal voltage)	≤ 20 ms

Inputs and Outputs

Current Inputs

Quantity	6 x Phase & 2 x Earth
Rated Current IN	1/5A
Measuring Range	80 x In
Instrumentation ≥ 0.1xIn	±1% In
Frequency	50/60Hz
Thermal Withstand:	
Continuous	3.0 x In
10 Minutes	3.5 x In
5 Minutes	4.0 x In
3 Minutes	5.0 x In
2 Minutes	6.0 x In
3 Seconds	57.7A (1A) 202A (5A)
2 Seconds	70.7A (1A) 247A (5A)
1 Second	100A (1A) 350A (5A)
1 Cycle	700A (1A) 2500A (5A)
Burden @ In	≤ 0.1VA (1A phase and Earth element) ≤ 0.3VA (5A phase and earth element)

Voltage Inputs

Quantity	1 (optional)
Nominal Voltage	40 - 160V a.c.
Instrumentation ≥ 0.8xVn	±1% Vn
Thermal Withstand:	
Continuous	300V
1 Second	
Burden @ 110V	≤ 0.1 VA

Auxiliary supply

Nominal voltage	Operating Range
24 - 250V dc	19.2 - 275 V dc
100 - 230V ac	80 - 253 V ac

Nominal Voltage	Quiescent Burden (typical)	Quiescent Burden (back-light)
24V dc	6.0W	7.4W
48V dc	5.8W	7.1W
60V dc	5.8W	7.0W
110V dc	6.5W	7.5W
125V dc	5.4W	1.2W
220V dc	5.2W	6.4W
250V dc	5.2W	6.4W
100V ac	13.4VA	15.9VA
110V ac	13.7VA	16.2VA
115V ac	13.7VA	16.2VA
120V ac	14.0VA	16.6VA
200V ac	16.0VA	19.0VA
230V ac	17.0VA	20.2VA

Binary Inputs

Operating Voltage	19V dc: Range 17 to 290V dc 88V dc: Range 74 to 290V dc
Maximum dc current for operation	1.5mA

Binary Outputs

Operating Voltage	Voltage Free
Operating Mode	User selectable - Self or Hand Reset
Contact Operate / Release Time.	7ms / 3ms
Making Capacity: Carry continuously Make and carry (L/R ≤ 40 ms and V ≤ 300 V)	5A ac or dc 20A ac or dc for 0.5s 30A ac or dc for 0.2s
Breaking Capacity (≤ 5 A and ≤ 300 V): AC Resistive AC Inductive DC Resistive DC Inductive	1250 VA 250 VA at p.f. ≤ 0.4 75 W 30 W at L/R ≤ 40ms 50 W at L/R ≤ 10ms

Mechanical Tests

Vibration (Sinusoidal)

IEC 60255-21-1 Class I

Type	Level	Variation
Vibration response	0.5 gn	≤ 5 %
Vibration endurance	1.0 gn	≤ 5 %

Shock and Bump

IEC 60255-21-2 Class I

Type	Level	Variation
Shock response	5 gn, 11 ms	≤ 5 %
Shock withstand	15 gn, 11 ms	≤ 5 %
Bump test	10 gn, 16 ms	≤ 5 %

Seismic

IEC 60255-21-3 Class I

Type	Level	Variation
Seismic response	1 gn	≤ 5 %

Mechanical Classification

Durability	>10 ⁶ operations
------------	-----------------------------

Electrical Tests

Insulation

IEC 60255-5

Type	Level
Between any terminal and earth	2.0 kV AC RMS for 1 min
Between independent circuits	2.0 kV AC RMS for 1 min
Across normally open contacts	1.0 kV AC RMS for 1 min

Transient Overvoltage

IEC 60255-5

Between all terminals and earth or between any two independent circuits	5 kV 1.2/50 μs 0.5 J
---	----------------------------

High Frequency Disturbance

IEC 60255-22-1 Class III

Type	Level	Variation
Common (longitudinal) mode	2.5 kV	≤ 5 %
Series (transverse) mode	1.0 kV	≤ 5 %

Electrostatic Discharge

IEC 60255-22-2 Class IV

Type	Level	Variation
Contact discharge	8.0 kV	≤ 5 %

Fast Transients

IEC 60255-22-4 Class IV

Type	Level	Variation
5/50 ns 2.5 kHz repetitive	4kV	≤ 5 %

Surge Immunity

IEC 60255-22-5

Type	Level	Variation
Between all terminals and earth	4.0 kV	≤ 10 %
Between any two independent circuits	2.0kV	

Conducted Radio Frequency Interference

IEC 60255-22-6

Type	Level	Variation
0.15 to 80 MHz	10 V	≤ 5 %

Radiated Radio Frequency

IEC 60255-25

Type	Limits at 10 m, Quasi-peak
30 to 230 MHz	40 dB(μ V)
230 to 10000 MHz	47 dB(μ V)

Conducted Radio Frequency

Type	Limits	
	Quasi-peak	Average
0.15 to 0.5 MHz	79 dB(μ V)	66 dB(μ V)
0.5 to 30 MHz	73 dB(μ V)	60 dB(μ V)

Radiated Immunity

IEC 60255-22-3 Class III

Type	Level	Variation
80 MHz to 1000 MHz	10 V/m	$\leq 5\%$

Magnetic Field with Power Frequency

IEC 61000-4-8, Class V

100 A/m continuous	50Hz; 1.257mT
1000 A/m for 3s	

Climatic Tests

Temperature

IEC 60068-2-1/2

Operating Range	-10 °C to +55 °C
Storage range	-25 °C to +70 °C

Humidity

IEC 60068-2-3

Operational test	56 days at 40 °C and 93 % relative humidity
------------------	---

IP Ratings

Type	Level
Installed with cover	IP 51 from front of relay
Installed with cover removed	IP 20 from front of relay

Performance

27/59 Under/Over Voltage

Number of Elements	4 Under or Over
Setting Range Vs	5, 5.5...200V
Hysteresis Setting	0. 0.1...80%
Vs Operate Level	100% Vs, ±1% or ±0.25V
Reset Level: Undervoltage	(100% + hyst) x Vop, ±1% or 0.25V
Overvoltage	(100% - hyst) x Vop, ±1% or 0.25V
Delay Setting td	0.00, 0.01...20, 20.5...100, 101...1000, 1010...10000, 10100...14400s
Basic Operate Time : 0 to 1.1xVs 0 to 2.0xVs 1.1 to 0.5xVs	73ms ±10ms 63ms ±10ms 58ms ±10ms
Operate time following delay.	Tbasic + td , ±1% or ±10ms
Inhibited by	Binary or Virtual Input U/V Guard

37, 37G Undercurrent

Number of Elements	Phase (37) x 2 Earth (37G) x 2
Setting Range Is	0.05, 0.10...5.0 x In
Operate Level	100% Is, ±5% or ±1% x In
Delay Setting td	0.00, 0.01...20, 20.5...100, 101...1000, 1010...10000, 10100...14400s
Basic Operate Time: 1.1 to 0.5xIn	35ms ±10ms
Operate time following delay.	Tbasic + td , ±1% or ±10ms
Overshoot Time	< 40ms
Inhibited by	Binary or Virtual Input U/I Guard (37)

46 Negative Phase Sequence Overcurrent

Number of Elements	DT & IT
DT Setting Range Is	0.05, 0.06...4.0 x In
DT Operate Level	100% Is, ±5% or ±1% x In
DT Delay Setting td	0.00, 0.01...20, 20.5...100, 101...1000, 1010...10000, 10100...14400s
DT Basic Operate Time: 0 to 2 x Is	40ms ±10ms
DT Operate time following delay.	Tbasic + td , ±1% or ±10ms
IT Char Setting	IEC: NI,VI,EI,LT ANSI: MI,VI,EI DTL
IT Setting Range	0.05, 0.06...2.5
Tm Time Multiplier	0.025, 0.050...1.6
Char Operate Level	105% Is, ±4% or ±1% In
Overshoot Time	< 40ms
Inhibited by	Binary or Virtual Input

49 Thermal Overload

Operate levels	Operate and Alarm
Setting Range Is	0.10, 0.11...3.0 x In
Operate Level	100% Is, ±5% or ±1% x In
Time Constant Setting	1, 1.5...1000min
Operate time	$t = \tau \times In \left\{ \frac{I^2 - I_p^2}{I^2 - (k \times I_B)^2} \right\}$ ±5% absolute or ±100ms where Ip = prior current
Alarm Level	Disabled, 50, 51...100%
Inhibited by	Binary or Virtual Input

50 Instantaneous & DTL OC&EF

Elements	Phase (OC), Derived Earth (N) and Measured Earth (G)
Number of Elements	2 x OC 2 x Derived EF (N) 2 x Measured EF (G)
Setting Range Is	0.05, 0.06...50 x In (OC, N) 0.005...25 x In (G)
Time Delay	0.00...14400s
Operate Level	100% Is, ±5% or ±1% x In
Operate time: 50, 50G	0 to 2xIs – 35ms, ±10ms, 0 to 5xIs – 25ms, ±10ms
50N	0 to 2xIs – 40ms, ±10ms, 0 to 5xIs – 30ms, ±10ms
Operate time following delay	Tbasic + td , ±1% or ±10ms
Inhibited by	Binary or Virtual Input Inrush detector

51Time Delayed OC&EF)

Elements	Phase (OC), Derived Earth (N) and Measured Earth (G)
Number of Elements	2 x OC 2 x Derived EF (N) 4 x Measured EF (G)
Characteristic	IEC: NI,VI,EI,LTl ANSI: MI,VI,EI DTL
Setting Range Is	0.05, 0.1...2.5 x In (OC, N) 0.005, 0.01...1.0 x In (G)
Time Multiplier	0.025,0.05...1.6
Time Delay	0, 0.01... 20s
Operate Level	105% Is, ±4% or ±1%×In
Minimum Operate time IEC	$t_{op} = \frac{K}{\left[\frac{I}{I_N}\right]^r - 1} \times Tm$
ANSI	$t_{op} = \left[\frac{A}{\left[\frac{I}{I_N}\right]^p - 1} + B \right] \times Tm$ ± 5 % absolute or ± 30 ms
Follower Delay	0 - 20s
Reset	ANSI decaying, 0 – 60s
Inhibited by	Binary or Virtual Input Inrush detector

50BF Circuit Breaker Fail

Operation	Current check
Setting Range Is	0.05,0.055...2.0 x In (Phase) 0.005,0.010...2.0 x In (Earth)
2 Stage Time Delays	Timer 1 0,5...60000ms Timer 2 0,5...60000ms
Operate Level	100% Is, ±5% or ±1%×In
Basic Operate time	< 20ms
Operate time following delay	Tdelay ±1% or ±10ms
Triggered by	Any function mapped as trip contact.
Inhibited by	Binary or Virtual Input

59N Neutral Voltage Displacement

Number of Elements	DT & IT
DT Setting Range Is	1...100V
DT Operate Level	100% Vs, ±5% or ±1%×Vn
DT Delay Setting td	0 ...14400s
DT Basic Operate Time 0V to 1.5×Vs	76ms ±20ms
DT Operate time following delay.	Tbasic + td , ±1% or ±20ms
IT Setting Range	1...100V
Tm Time Multiplier(IDMT)	0.1...140
Delay (DTL)	0...20s
Reset	ANSI Decaying, 0 ... 60s
Char Operate Level	105% Vs, ±2% or ± 0.5V
Inhibited by	Binary or Virtual Input

64H Restricted Earth Fault

Setting Range	0.005...0.95×In
Operate Level	100% Is, ±5% or ±1%×In
Time Delay	0.00... 14400s
Basic Operate Time	0 to 2 x Is: 45ms ±10ms 0 to 5 x Is: 35ms ±10ms
Inhibited by	Binary or Virtual Input

74TCS Trip Circuit Supervision

Number of supervisable circuits	6
Number of BI's Required	1 or 2 per function

81 Under/Over Frequency

Number of Elements	6 Under or Over
Setting Range Vs	40 ... 69.99Hz
Hysteresis Setting	0. 0.1...80%
Vs Operate Level	100% Fs, ±10mHz
Reset Level:	
Over frequency	(100% - hyst) x Fop, ±10mHz
Under frequency	(100% + hyst) x Fop, ±10mHz
Delay Setting td	0.00, 0.01...20, 20.5...100, 101...1000, 1010...10000, 10100...14400s
Basic Operate Time : (for ROCOF between 0.1 and 5.0 Hz/sec)	Typically <110ms Maximum <150ms
Operate time following delay.	Tbasic + td , ±1% or ±10ms
Inhibited by	Binary or Virtual Input

87BD Biased Differential

Number of Elements	1
Setting Range	
Initial	0.1, 0.15 ... 2 x In
1 st Bias Slope	0.1, 0.15 ... 0.7x
1 st Bias Slope Limit	1, 2 ... 20 x In
2 nd Bias Slope	1, 1.5 ... 2x
2 nd Bias Slope Type	Line, curve
Operate Level:	
Initial setting	±5% of setting or ±0.01 In
Bias slope	±10% of setting or ±0.01 In
Reset Level:	
Over frequency	(100% - hyst) x Fop, ±10mHz
Under frequency	(100% + hyst) x Fop, ±10mHz
Delay Setting td	0.000, 0.005 ... 1s
Basic Operate Time : (inrush action Enabled)	
0 to 3 x IOP	35ms ±10ms
0 to 10 x IOP	30ms ±10ms
Operate time following delay.	Tbasic + td , ±1% or ±10ms
Inhibited by	Binary or Virtual Input

Case Dimensions

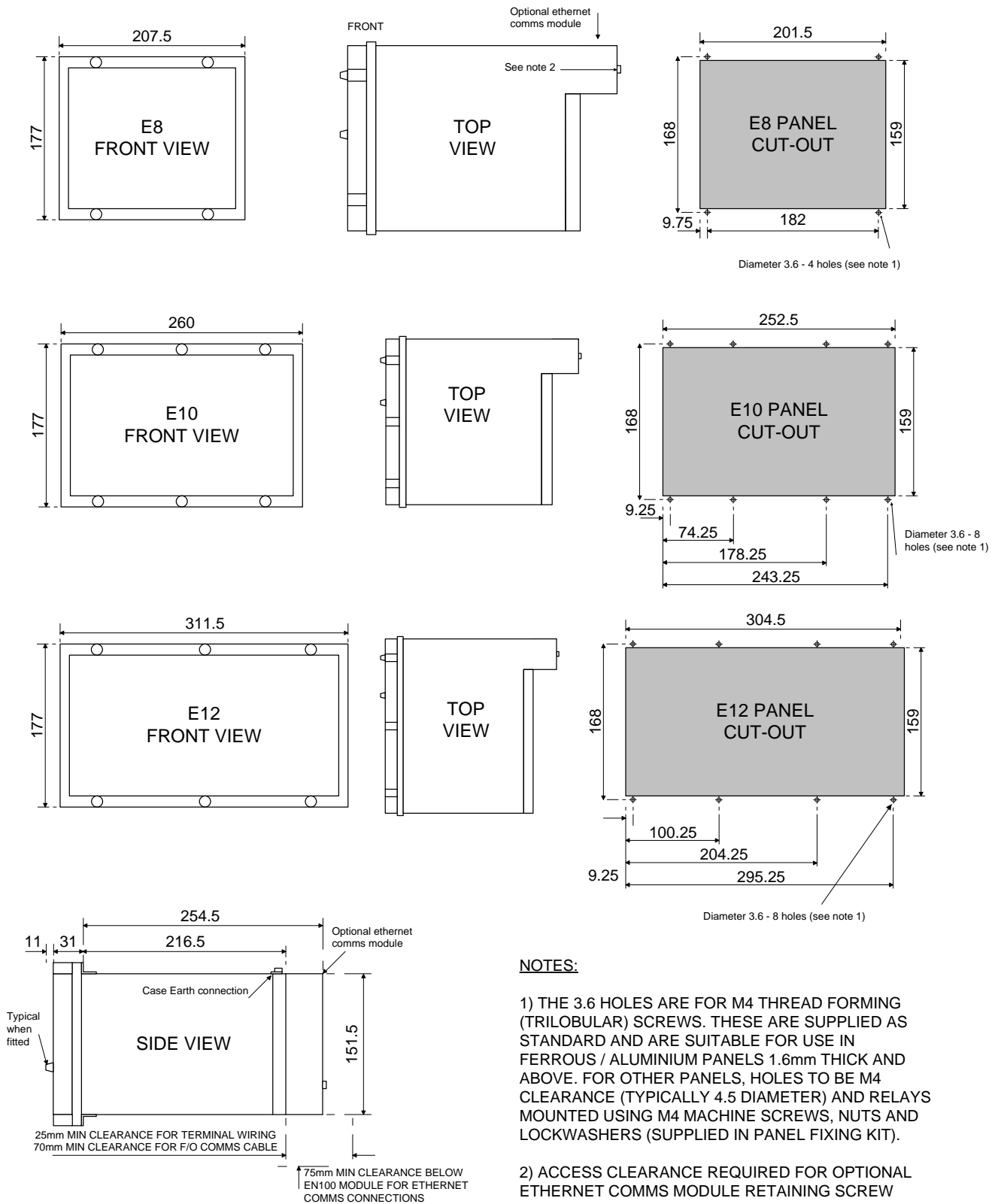
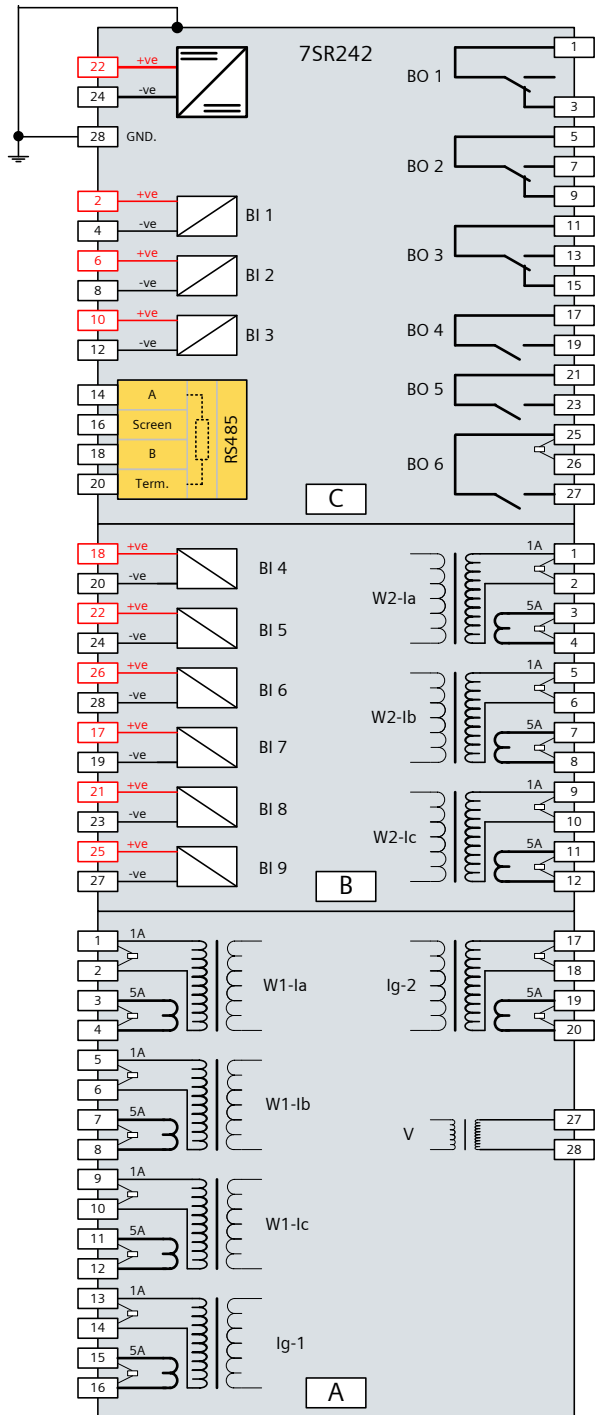
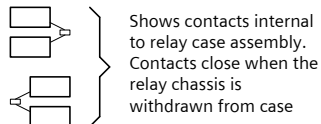

Fig. 5: 7SR242 Case Dimensions

7SR24 Connection Diagram



NOTES
 BI = Binary Input
 BO = Binary Output



Rear View: Arrangement of terminals and modules

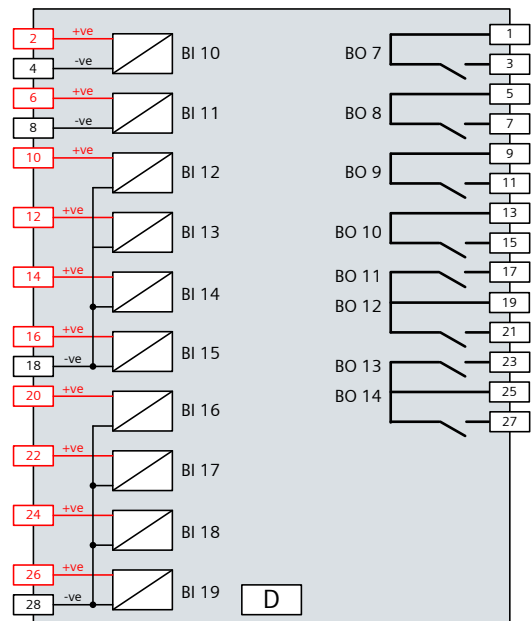
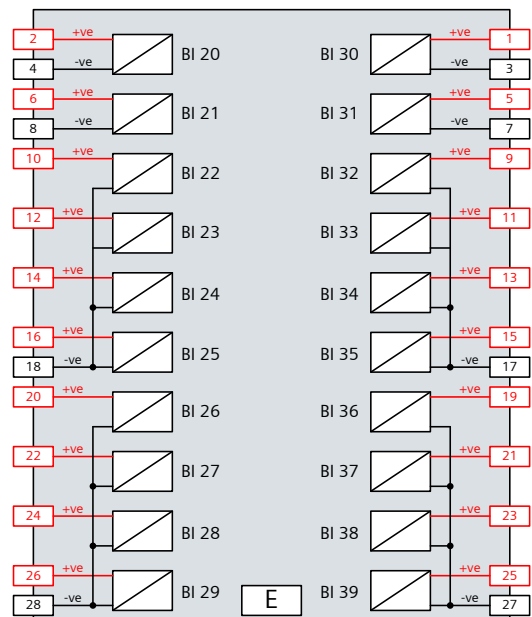
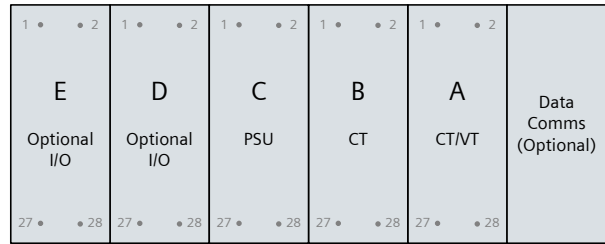

Fig. 6: 7SR24 Wiring Diagram

7SR24 Function diagram / example of external connections

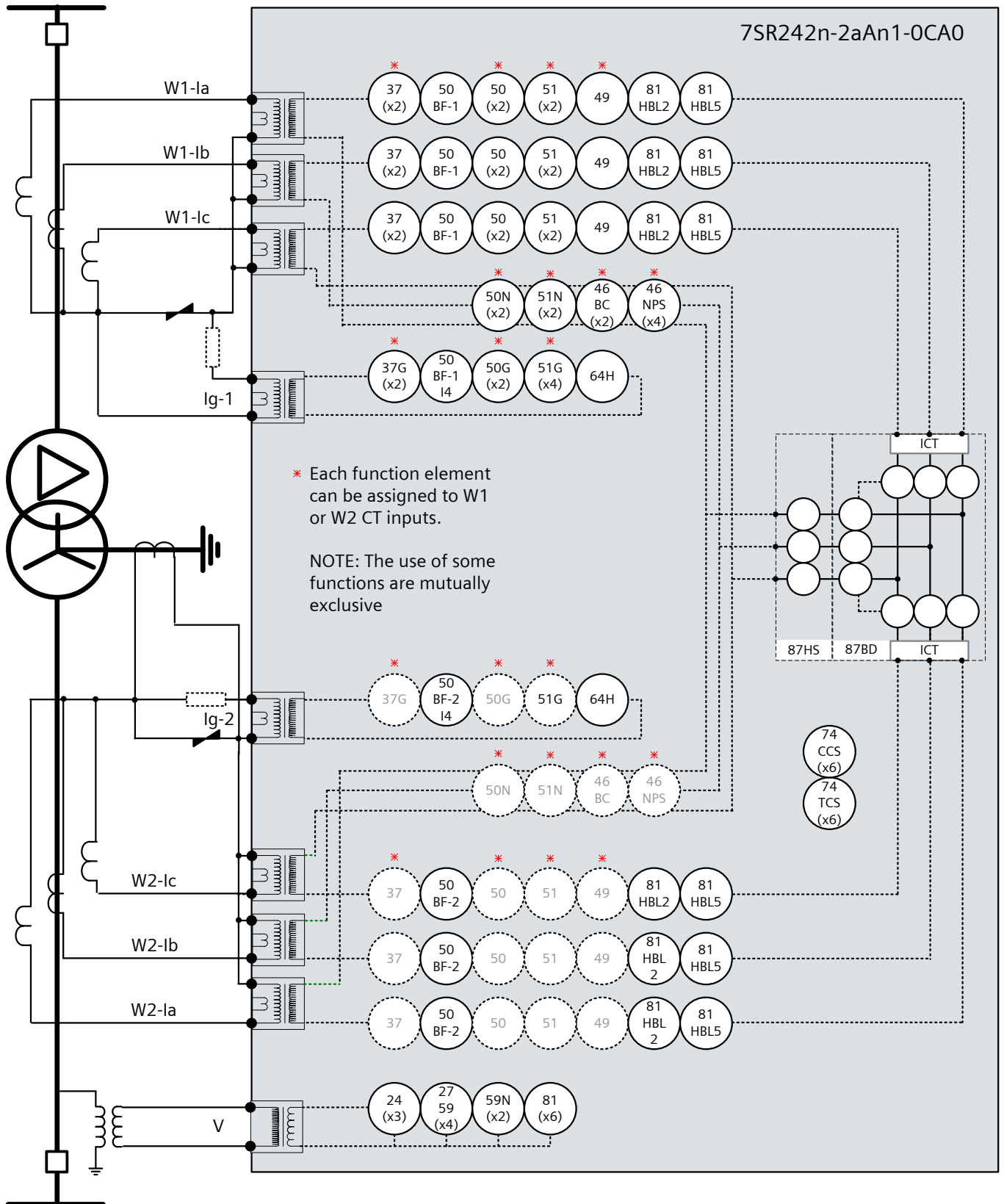

Fig. 7: Standard and Optional Functionality of 7SR24 Relay

Ordering Information – 7SR24 2 Winding Transformer Protection

Product description	Variants	Order No.
Duobias Multifunctional 2 winding transformer differential protection	<u>Protection Product</u> Transformer	7 S R 2 4 2 □ - 2 □ A □ □ - 0 □ A 0 ↑ ↑ ↑ ↑ ↑ ↑ ↑ ↑ ↑ ↑ ↑ ↑ ↑ 4 2 2 2 2 2 2 2 2 2 2 2 2
	<u>Relay Type</u> Differential (2 winding)	
	<u>Case I/O and Fascia</u> E8 case, 6 CT, 2 EF/REF CT, 1 VT, 9 Binary Inputs / 6 Binary Outputs, 16 LEDs E10 case, 6 CT, 2 EF/REF CT, 1 VT, 19 Binary Inputs / 14 Binary Outputs, 24 LEDs E12 case, 6 CT, 2 EF/REF CT, 1 VT, 39 Binary Inputs / 14 Binary Outputs, 32 LEDs	
	<u>Measuring Input</u> 1/5 A, 40/160V, 50/60Hz	
	<u>Auxiliary voltage</u> 24-250V DC / 100-230V AC. Binary input threshold 19V DC 24-250V DC / 100-230V AC. Binary input threshold 88V DC	
	<u>Communication Interface</u> Standard version – included in all models, USB front port, RS485 rear port Standard version – plus additional rear F/O ST connectors (x2) and IRIG-B Standard version – plus additional rear RS485 (x1) and IRIG-B Standard version – plus additional rear RS232 (x1) and IRIG-B Standard version – plus additional rear Electrical Ethernet RJ45 (x2) Standard version – plus additional rear Optical Ethernet Duplex (x2)	
	<u>Protocol</u> IEC 60870-5-103 and Modbus RTU (user selectable setting) IEC 60870-5-103 and Modbus RTU and DNP 3.0 (user selectable) IEC 60870-5-103 and Modbus RTU and DNP 3.0 (user selectable) and IEC61850	
	<u>Protection Function Packages</u> <u>Option A:</u> Standard version – Included in all models - 81HBL2 Inrush Detector - 81HBL5 Overfluxing detector - 87BD Biased current differential - 87HS Current differential highset Programmable logic For each winding/circuit breaker - 50BF Circuit breaker fail - 64H High impedance REF - 74TCS/CCS Trip/Close circuit supervision	
	<u>Option B:</u> Standard version – plus - 37/37G Undercurrent - 46BC Open circuit - 46NPS Negative phase sequence overcurrent - 49 Thermal overload - 50 Instantaneous phase fault overcurrent - 50G/50N Instantaneous earth fault - 51 Time delayed phase fault overcurrent - 51G/51N Time delayed earth fault (continued on following page)	

Ordering Information – 7SR24 2 Winding Transformer Protection

Product description	Variants	Order No.
---------------------	----------	-----------

Duobias

7 S R 2 4 2 □ - 2 □ A □ □ - 0 □ A 0

(continued from previous page)

<u>Option C:</u>	Standard version - plus
- 24	Overfluxing
- 27/59	Under/overvoltage
- 59N	Neutral voltage displacement
- 81	Under/overfrequency
- 37/37G	Undercurrent
- 46BC	Open circuit
- 46NPS	Negative phase sequence overcurrent
- 49	Thermal overload
- 50	Instantaneous phase fault overcurrent
- 50G/50N	Instantaneous earth fault
- 51	Time delayed phase fault overcurrent
- 51G/51N	Time delayed earth fault

C
|
A

Additional Functionality
No Additional Functionality

1) For ESI48-4 compliance of binary inputs external resistors are required – see Technical Manual.

Published by and copyright © 2017:

Siemens Protection Devices Limited

P.O. Box 8

North Farm Road

Hebburn

Tyne & Wear

NE31 1TZ

United Kingdom

Phone: +44 (0)191 401 7901

Fax: +44 (0)191 401 5575

E-mail: marketing.spdl.gb@siemens.com

EMEA-C10035-00-76GB

December 2017

For enquires please contact our Customer Support Center

Phone: +49 180/524 8437 (24hrs)

Fax: +49 180/524 24 71

E-mail: support.energy@siemens.com

www.siemens.com/protection

Subject to change without notice, Printed in the UK.

www.siemens.com/reynolle