

L.V. Switches

upto 63A, 500V, A.C. 50Hz

Application

Siemens offer L.V. Switches designed for different applications such as :

| Type of Switch | Basic Type | Maximum Continuous Rating Amps |
|------------------------|------------|--------------------------------|
| Heavy Duty Switches | 3LAO | 63 |
| Motor Control Switches | 3LAO | 63 |

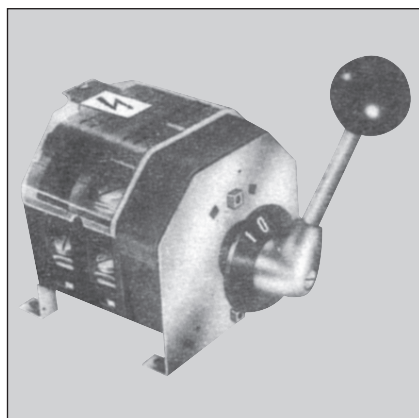

The switches can be supplied in open execution or in sheet steel enclosure.

The switches are known for their versatile design, high making and breaking capacity, long mechanical and contact life and the many safety features that are provided.

Construction

The 3LAO switches are available in size 2 for 25 Amps. and size 6 for 63 Amps. They are made up of uniform switching packets

assembled to form a stack. Each packet consists of 2 sets of contacts whose moving contacts are operated by moulded plastic cams when the operating shaft is turned. The stacking of similar packets renders it possible to build switches for practically all types of small drives, offering at the same time a uniform appearance. This and their compactness make them ideal for installation on machine tools.

The 3LAO switches are ordinarily supplied with either black moulded plastic ball handles or machine handles.

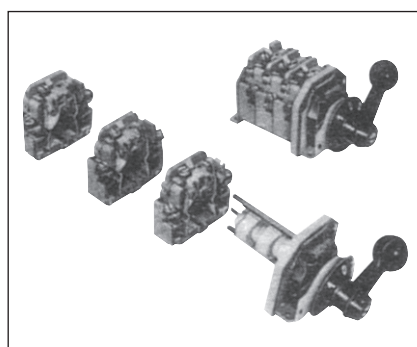

Switches with red ball handle or red machine handle can be supplied on request. The handle engages with the indicating dial by means of serrations. After the cap nut has been loosened, the handle can be fixed in any one of 16 different positions. In this way, the position of the handle can be adjusted to the mounting requirements in each individual case.

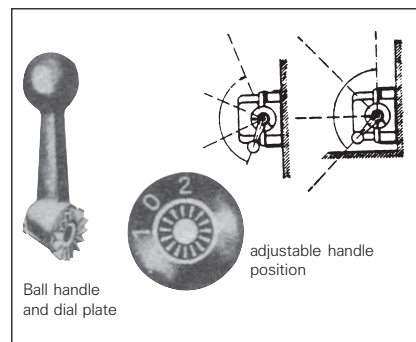

Switching Capacity

The Motor Control Switches and HP Rated Switches are suitable for reliable and safe starting and stopping of 3-phase A.C. motors even under heavy starting and, locked rotor conditions. They can be classified as motor-duty switches of AC 3 category, of duty according to IS : 4064 / 1978.

The 3LAO switches are suitable for frequency of operations upto 200 switching cycles per hour.

The maximum rating of the HRC fuses for short circuit protection is 25 Amps and 63 Amps for 3LAO switches size 2 and size 6 respectively.

Life

The mechanical life of 3LAO switches is about 5 million switching cycles. Due to high making and breaking capacity, the switches have a very long contact life, so much so that there is hardly any necessity of maintaining spare contacts.

Connection

The terminals of 3LAO switches are easily accessible, being arranged in tiers in the upper part of the switches and are designed for connecting straight wire ends by means of arched spring washers. There is no need to prepare the lead ends (e.g. eye bending) or to remove the terminal screws entirely for making the connections. The switch screws have only to be loosened and the bare wire ends put under the terminal washers

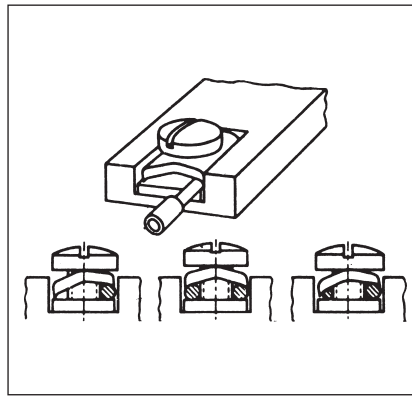

are clamped tight. The terminal washers are so designed that 2

conductors of equal or different cross-sections upto 4 sq. mm. for size 2 and 16 sq. mm. for size 6, can be connected on the terminal. Fine stranded conductors should preferably be connected by means of end sleeves (no soldering). For conductors of higher cross-section, special intermediate copper pieces (ICP) should be used.

Motor Control Switches

| Description | Max. permissible rated motor output at 415V 3-phase 50 Hz kW | Continuous current rating Amps. | No. of switching packets | Executions | |
|---|---|------------------------------------|--------------------------|----------------------------------|----------------------------------|
| | | | | Open Type | In Sheet steel housing Type |
| On-Off Switch | 7.5 30 | 25 63 | 2 2 | 3LAO 201 – 1YA 3LAO 601 – 1YB | 3LAO 221 – 1YA 3LAO 621 – 1YB |
| System Selector Switch | 5.5 30 | 25 63 | 3 3 | 3LAO 202 – 1YA 3LAO 602 – 1YB | 3LAO 222 – 1YA – |
| Reversing Switch | 5.5 30 | 25 63 | 3 3 | 3LAO 203 – 1YA 3LAO 603 – 1YB | 3LAO 223 – 1YA – |
| Star-Delta Switch | 12 30 | 25 63 | 4 4 | 3LAO 204 – 5YA 3LAO 604 – 1YB | – – |
| Two Speed Pole Changing Switch (Separate windings) | 5.5 | 25 | 3 | 3LAO 205 – 2YA | – |
| Two speed Pole Changing Switch (Dahlander windings) | 5.5 | 25 | 4 | 3LAO 205 – 1YA | – |
| Reversing Pole Changing Switch (Dahlander windings) | 5.5 | 25 | 6 | 3LAO 205 – 3YA | – |

Heavy Duty Switches

The Heavy Duty Switches find application in the distribution networks for general control of feeders. The heavy duty switches are described in IS:4064-1978, according to which they are capable of making and breaking 3 times the rated current at a rated voltage, and at a power factor of 0.35. Many industrial installations today run at a low power factor, and only heavy duty switches can make and break such circuits with absolute safety and with long contact life.

2 & 4 poles Switches

| No. of Poles | Rated Current Amps. | Open Type |
|--------------|---------------------|----------------|
| 2 | 25 | 3LAO 205 – 4YA |
| | 63 | 3LAO 605 – 1YB |
| 4 | 25 | 3LAO 205 – 5YA |
| | 63 | 3LAO 605 – 2YB |

Accessories



Wing Knobs

The 3LAO switches can also be used with a standard wing knob or a double wing knob. These knobs occupy very little space and can be used with advantage when 3LAO switches are mounted on switchboards, control boards, etc.

Door Interlocking

The 3LAO 'ON-OFF' switches with a side drive can be used with an interlocking hook at the end of the shaft, so that it is possible to interlock the hinged door of a housing. The door can then be opened only when the switch is in the 'OFF' position.

Front Drive

The 3LAO switches can be used with a detachable front drive. This facility is useful for installations where space saving front-of-board operation is advantageous.



The drive can be supplied with the facility of door interlock.

Protective Cover

The switches can be used with a transparent protective cover to prevent accidental contact with the live terminals.

Locking Discs

The switches can be used with two locking discs which enable the switch to be locked either in 'ON' or 'OFF' or both positions with the help of a padlock. As a matter of fact, upto 3 padlocks can be provided. This prevents operation of the switch without proper consent of the person concerned - an essential safety protection for maintenance work or for feeders involving remote control.



Dimensions (in mm)

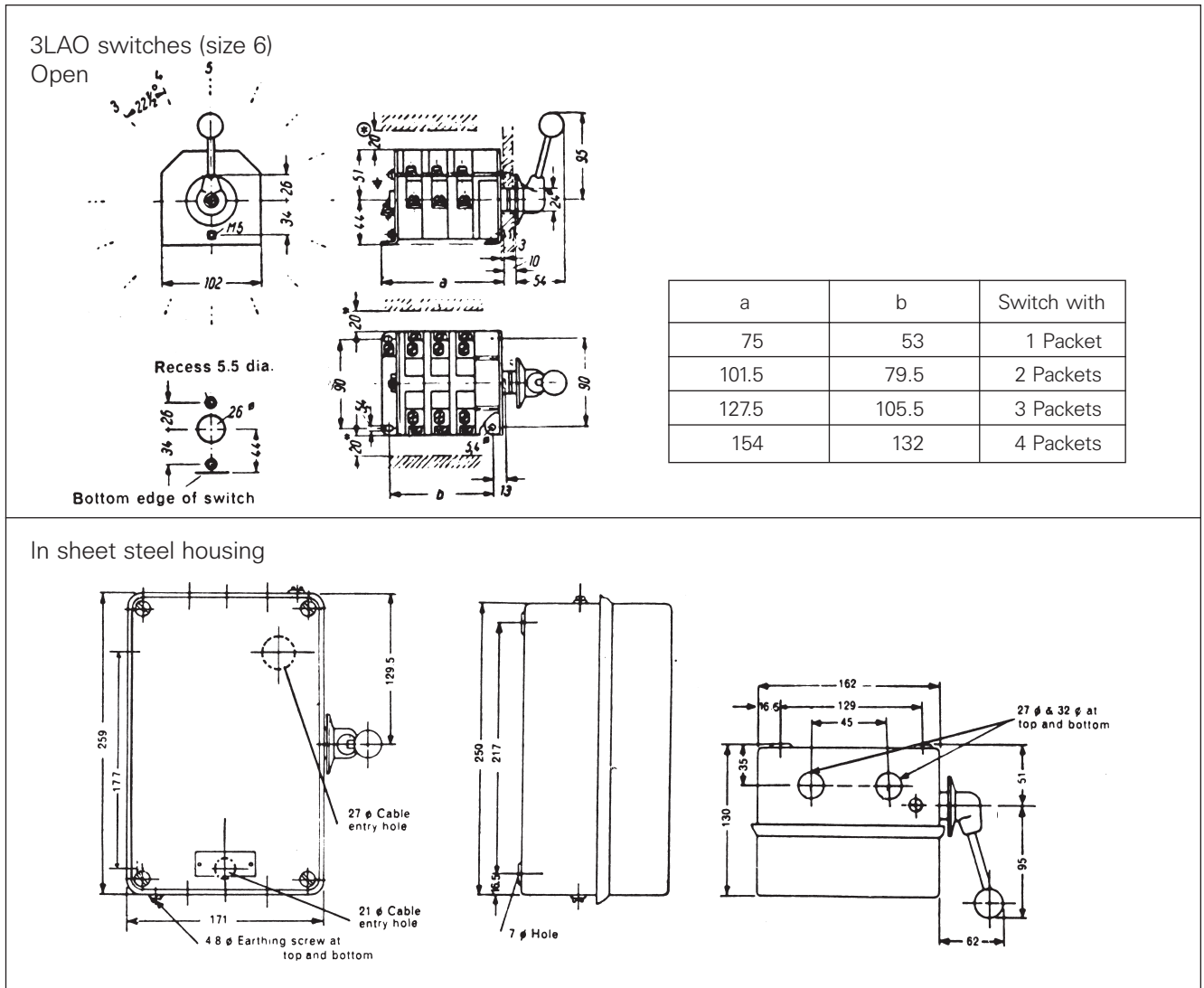

Dimensions (in mm)

3LAO switches (size 2)

Open

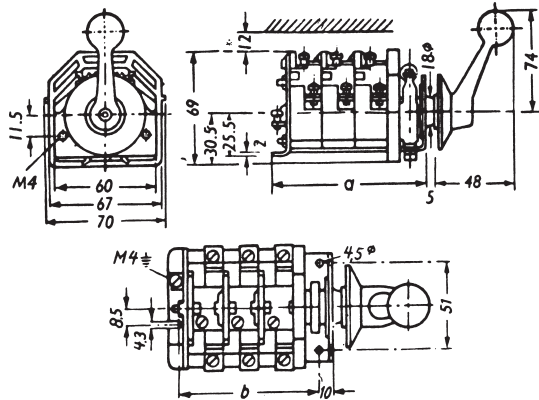

* Minimum clearance from metal parts (to be increased to 18 mm in case of 3LAO 204-5YA)

| a | b | Switch with |
|-------|-------|-------------|
| 57 | 41.5 | 1 packet |
| 77 | 61.5 | 2 packets |
| 97.5 | 82 | 3 packets |
| 118 | 102.5 | 4 packets |
| 138 | 122.5 | 5 packets |
| 158.5 | 143 | 6 packets |

In sheet steel housing

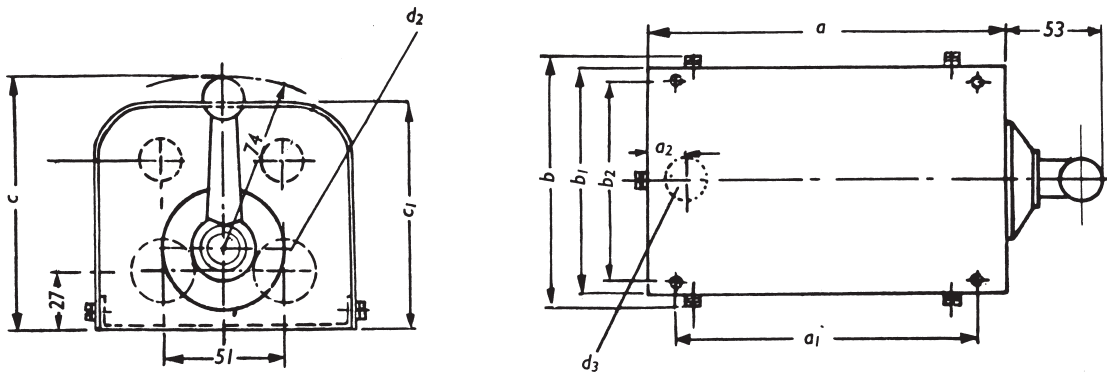

| Switch with | a | a ₁ | a ₂ | b | b ₁ | b ₂ | c | c ₁ | d ₂ | d ₃ |
|-----------------|-----|----------------|----------------|-----|----------------|----------------|-------|----------------|----------------|----------------|
| up to 3 Packets | 120 | 100 | 19.5 | 106 | 96 | 76 | 107.5 | 84 | 20 ø | 20 ø |

Standard Products Division,
 Low Voltage Controls & Distribution
 Thane Belapur Road,
 Post Box No. 85,
 Thane - 400 601
 Tel.: 91-22-760 0001
 Fax: 91-22-760 0076

Siemens Ltd.
 SGR-01-100-010
 This replaces SGR-01-100-008

"Product development is a continuous process. Consequently, the data indicated in this booklet is subject to change without prior notice. For the latest information please contact our Sales Office"