

Contents

Siemens Residential and Commercial Surge Protective Devices

Family SPDs	9-2
BoltShield™ Surge Protective Devices	9-4 – 9-6
TPS4 01 and TPS4 L1 (10 Mode)	9-7
TPS4 03	9-8
TPS4 05 and TPS4 L5 (10 Mode)	9-9
TPS4 06 and TPS4 L6 (10 Mode)	9-10
TPS4 09	9-11
TPS4 11	9-12
TPS4 12 and TPS4 L12 (10 mode)	9-13
TPS4 13	9-14
TPS4 15 and TPS4 L15 (10 mode)	9-15
Frequently Asked Questions	9-16

Surge Protection Devices (SPD)

Siemens Surge Protection Innovations

Introduction

In today's electronic world, home and business electrical systems just aren't complete unless they incorporate surge protection. **Stopping Surges Before They Get Into** these systems is best accomplished through the installation of appropriately sized hard-wired surge protective devices (SPDs) beginning at the incoming service followed by installations at other key surge entry points.

When Siemens first developed the Transient Protection System (TPS) family of surge protectors, we knew early on that hard-wired surge protectors needed fully coordinated safety controls. This led to the adoption of a number of SPD industry safety control firsts including the patented Ceramgard and TranSafe circuitry, coordinated fusing and thermal cutouts, dielectric isolation,

mechanical re-enforcing taping, etc... resulting in a design that ensures the highest possible electrical system surge protection and reliability.

Our next generation UL 1449 5th edition TPS SPDs carry on this same legacy. Every TPS is infused with Siemens engineering safety and performance "know-how." Siemens SPDs have the highest degree of safety while delivering the industry's best performance ratings – some of the lowest Voltage Protection Ratings (VPRs), Type 1 or 2 and 20 kA I-nominal ratings (for most models) with surge current ratings from 50 to 1000 kA.

The Siemens BoltShield family of residential and commercial products allows this to be done easily and at a reasonable cost.

Electrical disturbances will always occur, but they don't have to cause surge protectors to fail in an unsafe manner. Safer surge protection means uncompromised electrical system **protection, safety, and reliability.**

The following pages provide additional technical and ordering information concerning our entire offering of surge protection devices.

Internally Mounted SPDs



Features

- Per Phase Surge Current Capacity ranging from 100 kA to 500 kA
- Industry best VPRs
- $I_n = 20$ kA (most models)
- Across the board UL 96A compliance (most models)
- Ground Reference Monitoring (GRM) diagnostics

External or Wall Mounted SPDs



Features

- Per Phase Surge Current Capacity ranging from 50 kA to 1000 kA
- Industry best VPRs
- $I_n = 20$ kA (most models)
- Across the board UL 96A compliance (most models)
- Ground Reference Monitoring (GRM) diagnostics (excluding TPS4 03 & TPS4 09)

Residential SPDs











Features





- Per Phase Surge Current Capacity of 36, 40, 50, 60, 100 or 140 kA
- Ground Reference Monitoring (GRM) diagnostics

Surge Protection Devices (SPD)

Siemens Surge Protection Innovations

Surge Protector Per Phase Surge Current Capacities

Internal, External and Wall Mounted Standard Mode												
Per Phase Surge Current	50 kA	100 kA	130 kA	150 kA	200 kA	250 kA	300 kA	400 kA	500 kA	600 kA	800 kA	1000 kA
TPS4 01 		✓		✓	✓	✓	✓	✓	✓			
TPS4 03 	✓											
TPS4 05 		✓		✓	✓	✓	✓	✓	✓			
TPS4 06 		✓		✓	✓	✓	✓	✓	✓			
TPS4 09 			✓									
TPS4 11 		✓		✓	✓	✓						
TPS4 12 (coming soon) 		✓		✓	✓	✓	✓	✓	✓			
TPS4 13 		✓		✓	✓	✓	✓	✓				
TPS4 15 (coming soon) 										✓	✓	✓

10 Mode SPDs									
Per Phase Surge Current	100 kA	150 kA	300 kA	450 kA	500 kA	550 kA	600 kA	750 kA	900 kA
TSP4 L1 		✓	✓	✓		✓		✓	
TSP4 L5 		✓	✓	✓		✓		✓	
TSP4 L6 		✓	✓	✓		✓		✓	
TSP4 L12 (coming soon) 		✓	✓	✓		✓		✓	
TSP4 L15 (coming soon) 								✓	✓

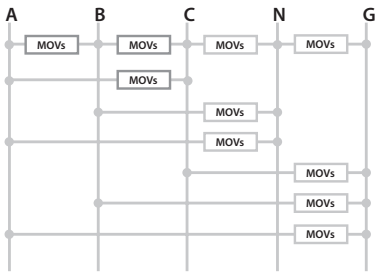
Discrete or True 10 Mode Style SPDs					
 <p>MOVs = Parallel MOVs</p>	<p>For mission critical or high profile applications, a growing number of end users prefer the assurance discrete or true 10-mode SPDs provide.</p> <p>When surges traverse the electrical system via phase to phase conductors, standard SPDs indirectly protect via the line to neutral or line to ground modes of protection. Siemens integral or wall mounted "Discrete" or "True" 10-mode SPDs address L-L surges by incorporating directly connected line to line surge protection elements. This style of SPD provides the "Just in Case" assurance mission critical or high profile projects require.</p>				

BoltShield™ Surge Protective Devices

BSPD – Commercial Surge Protection for Panel Boards

Catalogue Logic

BSPD series for panelboards

Ordering Information

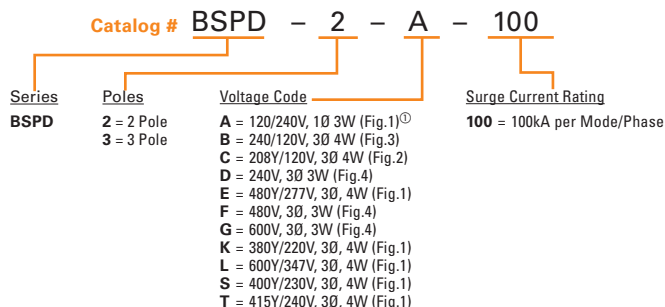

BSPD Series

Product specifications

General specifications	
Maximum surge current rating range	100 kA per phase
UL Type designation	SPD Type 1 ^②
UL 1449 I-nominal rating	20kA
UL 1449 short circuit current rating	200kA
Repetitive impulse	5,000 hits
Response time	<1 ns

Diagnostic monitoring specifications
Green/red visual mechanical flag failure indicators
Flashing dual color LED (green/red) status indicator
Audible alarm with silence switch/button
Form C dry contact, 240V AC, 1A max, 48V DC, 0.5A max

Design specifications
Monolithic distribution grade MOV
Integrated optimized thermal protection
Fits in footprint of BL/BQD, or xGB/3VA41 ^③
Modes of protection (L-N or L-G, L-L)

BSPD Catalog Numbers and UL 1449 performance data

Catalog numbers	System voltage	L-N (L-G)	L-L	I _n	SCCR	MCOV	Siemens breaker form factor
BSPD2A100 ^①	120/240V, 1Ø, 3W	600V	900	20kA	200kA	150V	2-P, BL/BQD or xGB/3VA41
BSPD3B100	240/120V, 3Ø, 4W	600V/800V	1200	20kA	200kA	150V	3-P, BL/BQD or xGB/3VA41
BSPD3C100	208Y/120V, 3Ø, 4W	600V	900	20kA	200kA	150V	3-P, BL/BQD or xGB/3VA41
BSPD3D100	240V, 3Ø, 3W	800V	1500	20kA	200kA	280V	3-P, BL/BQD or xGB/3VA41
BSPD3E100	480Y/277V, 3Ø, 4W	1000V	1800	20kA	200kA	320V	3-P, BL/BQD or xGB/3VA41
BSPD3F100	480V, 3Ø, 3W	1800V	3000	20kA	200kA	550V	3-P, BL/BQD or xGB/3VA41
BSPD3G100	600V, 3Ø, 3W	2000V	4000	20kA	200kA	700V	3-P, BL/BQD or xGB/3VA41
BSPD3K100	380Y/220V, 3Ø, 4W	900V	1800	20kA	200kA	320V	3-P, BL/BQD or xGB/3VA41
BSPD3L100	600Y/347V, 3Ø, 4W	1200V	2500	20kA	200kA	400V	3-P, BL/BQD or xGB/3VA41
BSPD3S100	400Y/230V, 3Ø, 4W	900V	1800	20kA	200kA	320V	3-P, BL/BQD or xGB/3VA41
BSPD3T100	415Y/240V, 3Ø, 4W	900V	1800	20kA	200kA	320V	3-P, BL/BQD or xGB/3V

Benefits of installing multiple BSPDs

Adding multiple BSPDs in a single panelboard can increase modes of protection and a surge capacity. See the BoltShield brochure for more details and review an example chart below:

Number of BSPDs	Connection	Modes of protection	Surge current capacity per mode	Surge current capacity per phase
1	Neutral	3	100kA	100kA
2	Neutral + Ground	6	100kA	200kA
2	Neutral(2)	3	200kA	200kA
3	Neutral(2) + Ground(1)	6	200kA(L-N) + 100kA (L-G)	300kA
3	Ground(3)	3	300kA	300kA
4	Neutral(2) + Ground(2)	6	200kA	400kA

^① Can also be used on 208Y/120V, 1Ø, 3W system.
^② Type 1 SPDs suitable for use in Type 2 applications.

^③ Each SPD comes with an adapter for xGB/3VA41 applications. Replacement adapter kit BSPDXGB1 is available, containing 2 and 3 pole adapters (1 each).

BoltShield™ Surge Protective Devices

QSPD – Residential Surge Protection for Load Centers

Catalogue Logic

QSPD series for load centers

Ordering Information

QSPD catalog number logic

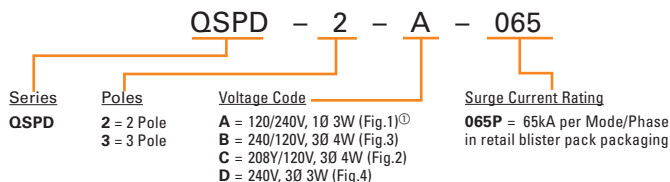

Product specifications

General specifications	QSPD
Maximum surge current rating range	65kA per phase
UL Type designation	SPD Type 1 ^①
UL 1449 I-nominal rating	20kA
UL 1449 short circuit current rating	200kA
Repetitive impulse	5,000 hits
Response time	<1 ns

Diagnostic monitoring specifications	QSPD
Green/red visual mechanical flag failure indicators	✓
Flashing dual color LED (green/red) status indicator	✓
Audible alarm with silence switch/button	✓
Design specifications	QSPD
Monolithic distribution grade MOV	✓
Integrated optimized thermal protection	✓
Fits in footprint of Siemens QP breaker	✓
Modes of protection (L-N or L-G, L-L)	✓

QSPD Catalog Numbers and UL 1449 performance data

Catalog numbers	System voltage	L-N (L-G)	L-L	I _n	SCCR	MCOV	Siemens breaker form factor
QSPD							
QSPD2A065P ^②	120/240V, 1Ø, 3W ^①	600V	1000	20kA	200kA	150V	2-P, QP
QSPD3B065	240/120V, 3Ø, 4W	600V/900V	1200	20kA	200kA	150V	3-P, QP
QSPD3C065	208Y/120V, 3Ø, 4W	600V	1000	20kA	200kA	150V	3-P, QP
QSPD3D065	240V, 3Ø, 3W	900V	1500	20kA	200kA	280V	3-P, QP

Benefits of installing multiple QSPDs

Adding multiple QSPDs in a single load center can increase the modes of protection and the surge capacity.

See the Boltshield brochure for more details and review the example chart below:

No. of QSPDs or QSPD-Bases	Connection	Modes of protection	Multiple QSPD	
			Surge current capacity per mode	Surge current capacity per phase
1	Neutral	3	65kA	65kA
2	Neutral + Ground	6	65kA	130kA
2	Neutral	3	130kA	130kA
3	Neutral(2) + Ground(1)	6	130kA(L-N) + 65kA (L-G)	195kA
3	Ground	3	195kA	195kA
4	Neutral(2) + Ground(2)	6	130kA	260kA

① Can also be used on 208Y/120V, 1Ø, 3W system.
② Type 1 SPDs suitable for use in Type 2 applications.

③ QSPD2A065P comes in retail style blister pack packaging.

BoltShield™ Surge Protective Devices

FSPD – Residential Externally Mounted SPDs NEW

Catalogue Logic

FSPD Series for External Applications

FSPD036

Features & Benefits

- UL 1449 Listed
- Type 1 rated SPD
- Surge Current Rating 36kA
- Nominal Rating 10kA
- Short Circuit Current Rating 200kA
- Voltage code A 120/240V, 1Ø, 3W
- Reduced mode of protection (L1-N, L2-N, L-L)
- LED Protection Status Monitoring (Single LED Standard)



FSPD060 | FSPD100 | FSPD140

Features & Benefits

- UL 1449 Listed
- Type 2 rated SPD
- Surge Current Rating:
 - FSPD060 60kA
 - FSPD100 100kA
 - FSPD140 140kA
- Nominal Rating 20kA
- Short Circuit Current Rating 200kA
- Voltage code A 120/240V, 1Ø, 3W
- All modes of protection (L-N, L-G, N-G)
- LED Protection Status Monitoring and audible alarm
- GRM (Ground Reference Monitoring), N-G>20V detected



9

SPD

FSPD Series Catalog Number and Performance data

Catalog numbers	System voltage	L-N	L-G	L-L	N-G	MCOV
FSPD036	120/240V, 1Ø, 3W	700	—	1200	—	180
FSPD060	120/240V, 1Ø, 3W	700	700	1200	700	180
FSPD100	120/240V, 1Ø, 3W	700	700	1200	700	180
FSPD140	120/240V, 1Ø, 3W	700	700	1200	700	180

SPD - Surge Protective Devices

TPS4 Integral or Internally Mounted SPDs

Selection

TPS4 01 and TPS4 L1 (True or Discrete 10-Mode)

Siemens TPS4 01 and L1 surge protective devices are designed for integration within our RP1, P2, and P3 power distribution panel boards, as well as TIASTAR motor control centers and busway systems. The TPS4 01 and L1 SPDs feature Ground Integrity Monitoring (GIM) diagnostics

TPS4 01 and TPS4 L1 Key Features

- UL 1449-5 Type 2 SPD and UL 1283 Listed
 - Optional UL 1449 5th edition Listed Type 1
- Type 1 / Type 2 SPD
- 100 - 500 kA Per Phase Surge Current
- 20 kA I_n
- 200 kA SCCR
- Voltage Protection Rating (VPRs)
 - 208/120 V, 3Ø, 4W: 500V
 - 480/277 V, 3Ø, 4W: 1000V
- UL 96A Lightning Protection Master Labeling compliant (@ 20 kA)
- New Large Block MOV Pill Stack Design
- Every MOV is monitored, including N-G
- Mounts internal to:
 - RP1, P2, and P3 panels
 - TIASTAR motor control centers – standard 6" bucket
 - STP series busplug on SX series busway
- Consult factory for field retrofit in P1 panels
- Modes of Protection: L-N, L-G, N-G, and L-L
- All UL required OCP & safety coordination included
 - Type 1 SPDs intended for line or load side of main disconnect
 - Type 2 SPDs intended for load side of main disconnect
- Standard Monitoring: LCD Event Counter with Time and Date Stamp, LED Indicators, Surge Counter, Dry Contacts, Audible Alarm w/ silence switch & test button
- Dimensions: 9.25" x 4.5" x 4.29"
(235 mm x 114.3 mm x 109 mm)
- Weight: 4.55 lb. (2.06 kg)
- Designed, manufactured & tested consistent with:
 - ANSI / IEEE C62.41.1-2002, C62.41.2-2002, C62.45-2002, C62.62-1010, C62.72-2007 and CSA C22.2 No. 269.1 and 269.2
 - 1992/2000 NEMA LS-1
 - NEC Article 285
 - IEC 61643, CE
- 10-year product warranty

Available Options:

- Direct bus connected or can be wired to a circuit breaker (include W option)



Ordering Information

Catalog # TPS4 01

Voltage Code	Surge Current (kA)	Options
A = 240/120 V, 1Ø, 3W ^①	10 = 100 kA per phase	X = Surge counter (Standard)
B = 240/120 V, 3Ø, 4W	15 = 150 kA per phase	0 = Std config (default)
C = 208/120 V, 3Ø, 4W	20 = 200 kA per phase	W = Terminal lug
W = 220/127 V, 3Ø, 4W	25 = 250 kA per phase	0 = Std config (default)
D = 240 V, 3Ø, 3W	30 = 300 kA per phase	B = Busway application
E = 480/277 V, 3Ø, 4W	40 = 400 kA per phase	M = MCC application
F = 480 V, 3Ø, 3W	50 = 500 kA per phase	
G = 600 V, 3Ø, 3W ^②		
K = 380/220 V, 3Ø, 4W		
L = 600/347 V, 3Ø, 4W		
S = 400/230 V, 3Ø, 4W		
T = 415/240 V, 3Ø, 4W		

Example: **TPS4C0120X000** = SPD for a 208/120V panelboard with a surge current capacity of 200 kA per phase and a surge counter option.
When an option is not selected, include a zero (0) in the field.

① Can also be used on 208Y/120V, 1Ø, 3W System
② Not available in 300, 400 or 500 kA versions

Please note: The TPS4 01 series is not suitable for use in the Original P1 Lighting Panels - Only Revised P1 Lighting Panels.



Ordering Information

Catalog # TPS4 L1

Voltage Code	Surge Current (kA)	Options
A = 240/120 V, 1Ø, 3W	15 = 150 kA per phase	X = Surge counter (Standard)
B = 240/120 V, 3Ø, 4W	30 = 300 kA per phase	0 = Std config (default)
C = 208/120 V, 3Ø, 4W	45 = 450 kA per phase	W = Terminal lug
W = 220/127 V, 3Ø, 4W	55 = 550 kA per phase	0 = Std config (default)
E = 480/277 V, 3Ø, 4W	75 = 750 kA per phase	B = Busway application
K = 380/220 V, 3Ø, 4W		M = MCC application
L = 600/347 V, 3Ø, 4W		
S = 400/230 V, 3Ø, 4W		
T = 415/240 V, 3Ø, 4W		

Example: **TPS4CL120X000** = SPD for a 208/120V panelboard with a surge current capacity of 200kA per phase and a surge counter option.
When an option is not selected, include a zero (0) in the field.

① Can also be used on 208Y/120V, 1Ø, 3W System
② Not available in 450, 550 or 750 kA versions

Please note: The TPS4 L1 series is not suitable for use in the Original P1 Lighting Panels - Only Revised P1 Lighting Panels.

SPD - Surge Protective Devices

TPS4 External or Wall Mounted SPDs

Selection

TPS4 03

TPS4 03 is a UL 1449 5th edition 50 kA Type 1 compact surge protective device that can be used as a replacement secondary surge or lightning arrestors. Having a Type 1 designation allows for flexible electrical system connection location (line or load side) as well as UL 96A compliance (@ 20 kA I_{n1}).

TPS4 03 Key Features

- UL 1449 5th edition Listed Type 1
- Type 1 Rated SPD
- 50 kA Per Phase Surge Current
- 20 kA I_{n1}
- 200 kA SCCR
- UL 96A Lightning Protection Master Labeling compliant (@ 20 kA)
- Every MOV is monitored
- Mounts external to electrical distribution equipment – Recommended for line side or load side application
- Standard compact NEMA 4X polycarbonate enclosure
- Modes of Protection: L-N or L-G and L-L
- Standard Monitoring: LED Indicator
- Dimensions: 4.25" x 2.41" x 2.75"
- Weight: .5 lb.
- 2-year product warranty

Available Options:

- Neutral to Ground Protection (option "N")



TPS4 03

Ordering Information

Catalog # TPS4 03

<p>Voltage Code</p> <p>A = 120/240 V, 1Ø, 3W B = 120/240 V, 3Ø, 4W C = 120/208 V, 3Ø, 4W W = 220/127 V, 3Ø, 4W D = 240 V, 3Ø, 3W E = 277/480 V, 3Ø, 4W F = 480 V, 3Ø, 3W G = 600 V, 3Ø, 3W K = 380/220 V, 3Ø, 4W L = 600/347 V, 3Ø, 4W S = 400/230 V, 3Ø, 4W T = 415/240 V, 3Ø, 4W</p>	<p>Surge Current (kA)</p> <p>05 = 50 kA per phase</p>	<p>Options</p> <p>0 = No Dry contact & No Audible alarm</p> <p>N = Adds N-G Protection</p>
--	--	---

SPD - Surge Protective Devices

TPS4 Integral or Internally Mounted SPDs

Selection

TPS4 05 and TPS4 L5 (True or Discrete 10-Mode)

Siemens TPS4 05 and L5 surge protective devices are designed for integration within our F2 and S5 panelboards as well as distribution switchboards. The TPS4 05 and L5 SPDs feature Ground Integrity Monitoring (GIM) diagnostics.

TPS4 05 and TPS4 L5 Key Features

- UL 1449 Type 2 SPD and UL 1283 Listed
 - Optional UL 1449 Listed Type 1
- Type 1 / Type 2 SPD
- 100 - 500 kA Per Phase Surge Current
- 20 kA I_n
- 200 kA SCCR
- Voltage Protection Rating (VPRs)
 - 208/120 V, 3Ø, 4W: 600V
 - 480/277 V, 3Ø, 4W: 1000V
- UL 96A Lightning Protection Master Labeling compliant (@ 20 kA)
- New Large Block MOV Pill Stack Design
- Every MOV is monitored, including N-G
- Mounts internal to:
 - F2 and S5 panelboards and distribution switchboards
- Modes of Protection: L-N, L-G, N-G, and L-L
- All UL required OCP & safety coordination included
 - Type 1 SPDs intended for line or load side of main disconnect
 - Type 2 SPDs intended for load side of main disconnect
- Standard Monitoring: LCD Event Counter with Time and Date Stamp, LED Indicators, Surge Counter, Dry Contacts, Audible Alarm w/ silence switch & test button
- Dimensions: 17" x 10" x 6"
(434 mm x 254 mm x 154 mm)
- Weight: 22 lbs. (10 kg)
- Designed, manufactured & tested consistent with:
 - ANSI / IEEE C62.41.1-2002, C62.41.2-2002, C62.45-2002, C62.62-1010, C62.72-2007 and CSA C22.2 No. 269.1 and 269.2
 - 1992/2000 NEMA LS-1
 - NEC Article 285
 - IEC 61643, CE
- 10-year product warranty

Panelboard Features:

- Copper or aluminum bus MB or MLO

Switchboard Features:

- Copper or aluminum bus
- 200% rated neutral bus for harmonic-rich applications
- CSA, UL 891, UL 67 and NEMA PB-2



TPS4 05

Ordering Information

Catalog # TPS4 05 X

Voltage Code	Surge Current (kA)	Options
A = 240/120V, 1Ø, 3W	10 = 100 kA per phase	X = Surge counter (Standard)
B = 240/120V, 3Ø, 4W	15 = 150 kA per phase	2 = Type 2 SPD (Default)
C = 208/120V, 3Ø, 4W	20 = 200 kA per phase	Includes UL 1283 EMI/RFI Filters
W = 220/127V, 3Ø, 4W	25 = 250 kA per phase	0 = Type 1 SPD
D = 240V, 3Ø, 3W	30 = 300 kA per phase	(Consult Factory Prior to Ordering)
E = 480/277V, 3Ø, 4W	40 = 400kA per phase	
F = 480V, 3Ø, 3W	50 = 500kA per phase	
G = 600V, 3Ø, 3W [Ⓢ]		
K = 380/220V, 3Ø, 4W		
L = 600/347V, 3Ø, 4W		
S = 400/230V, 3Ø, 4W		
T = 415/240V, 3Ø, 4W		

Example: **TPS4C0520X2** = SPD for a 208/120V panelboard with a surge current capacity of 200kA per phase and Type 2 SPD.

When an option is not selected, include a **zero (0)** in the field.

Ⓢ Not available in 300, 400 or 500kA versions



TPS4 L5

Ordering Information

Catalog # TPS4 L5 X

Voltage Code	Surge Current (kA)	Options
A = 240/120V, 1Ø, 3W	15 = 150 kA per phase	X = Surge counter (Standard)
B = 240/120V, 3Ø, 4W	30 = 300 kA per phase	2 = Type 2 SPD (Default)
C = 208/120V, 3Ø, 4W	45 = 450 kA per phase	Includes UL 1283 EMI/RFI Filters
W = 220/127V, 3Ø, 4W	55 = 550 kA per phase	0 = Type 1 SPD
E = 480/277V, 3Ø, 4W	75 = 750 kA per phase	
K = 380/220V, 3Ø, 4W		
L = 600/347V, 3Ø, 4W [Ⓢ]		
S = 400/230V, 3Ø, 4W		
T = 415/240V, 3Ø, 4W		

Example: **TPS4CL520X2** = SPD for a 208/120V panelboard with a surge current capacity of 200kA per phase and Type 2 SPD.

When an option is not selected, include a **zero (0)** in the field.

Ⓢ Not available in 450, 550 or 750kA versions

SPD - Surge Protective Devices

TPS4 Integral or Internally Mounted SPDs

Selection

TPS4 06 and TPS4 L6 (True or Discrete 10-Mode)

Siemens TPS4 06 and L6 surge protective devices are designed for integration within our FC, IPS, SB switchboards and low voltage switchgears. The TPS4 06 and L6 SPDs feature Ground Integrity Monitoring (GIM) diagnostics.

TPS4 06 and TPS4 L6 Key Features

- UL 1449 Type 2 SPD and UL 1283 Listed
 - Optional UL 1449 Listed Type 1
- Type 1 / Type 2 SPD
- 100 - 500 kA Per Phase Surge Current
- 20 kA I_n
- 200 kA SCCR
- Voltage Protection Rating (VPRs)
 - 208/120 V, 3Ø, 4W: 600V
 - 480/277 V, 3Ø, 4W: 1000V
- UL 96A Lightning Protection Master Labeling compliant (@ 20 kA)
- New Large Block MOV Pill Stack Design
- Every MOV is monitored, including N-G
- Mounts internal to:
 - FC, IPS, SB switchboards
 - Type WL low-voltage switchgear
- Modes of Protection: L-N, L-G, N-G, and L-L
- All UL required OCP & safety coordination included
 - Type 1 SPDs intended for line or load side of main disconnect
 - Type 2 SPDs intended for load side of main disconnect
- Standard Monitoring: LCD Event Counter with Time and Date Stamp, LED Indicators, Surge Counter, Dry Contacts, Audible Alarm w/ silence switch & test button
- Dimensions: 11" x 11" x 4.5"
(276 mm x 276 mm x 115 mm)
- Weight: 7.4 lbs (3.4 kg)
- Designed, manufactured & tested consistent with:
 - ANSI / IEEE C62.41.1-2002, C62.41.2-2002, C62.45-2002, C62.62-1010, C62.72-2007 & CSA C22.2 No. 269.1 and .2
 - 1992/2000 NEMA LS-1
 - NEC Article 285
 - IEC 61643, CE
- 10-year product warranty



TPS4 06

Ordering Information

Catalog # TPS4 06 X

Voltage Code

A = 240/120V, 1Ø, 3W
 B = 240/120V, 3Ø, 4W
 C = 208/120V, 3Ø, 4W
 W = 220/127V, 3Ø, 4W
 D = 240V, 3Ø, 3W
 E = 480/277V, 3Ø, 4W
 F = 480V, 3Ø, 3W
 G = 600V, 3Ø, 3W[Ⓛ]
 K = 380/220V, 3Ø, 4W
 L = 600/347V, 3Ø, 4W
 S = 400/230V, 3Ø, 4W
 T = 415/240V, 3Ø, 4W

Surge Current (kA)

10 = 100 kA per phase
 15 = 150 kA per phase
 20 = 200 kA per phase
 25 = 250 kA per phase
 30 = 300 kA per phase
 40 = 400 kA per phase
 50 = 500 kA per phase

Options

X = Surge counter (Standard)
 2 = Type 2 SPD (Default)
 Includes UL 1283 EMI/RFI Filters
 0 = Type 1 SPD

Example: **TPS4C0620X2** = SPD for a 208/120V panelboard with a surge current capacity of 200kA per phase and Type 2 SPD.

When an option is not selected, include a **zero (0)** in the field.

[Ⓛ] Not available in 300, 400 or 500kA versions

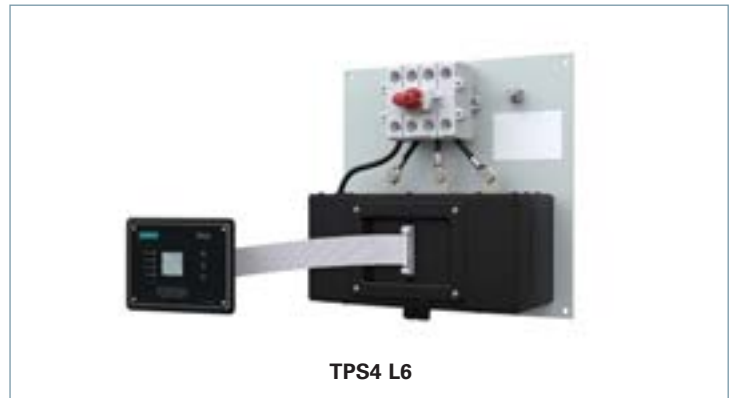

TPS4 L6

Ordering Information

Catalog # TPS4 L6 X

Voltage Code

A = 240/120V, 1Ø, 3W
 B = 240/120V, 3Ø, 4W
 C = 208/120V, 3Ø, 4W
 W = 220/127V, 3Ø, 4W
 E = 480/277V, 3Ø, 4W
 K = 380/220V, 3Ø, 4W
 L = 600/347V, 3Ø, 4W
 S = 400/230V, 3Ø, 4W
 T = 415/240V, 3Ø, 4W

Surge Current (kA)

15 = 150 kA per phase
 30 = 300 kA per phase
 45 = 450 kA per phase
 55 = 550 kA per phase
 75 = 750 kA per phase

Options

X = Surge counter (Standard)
 2 = Type 2 SPD (Default)
 Includes UL 1283 EMI/RFI Filters
 0 = Type 1 SPD

Example: **TPS4CL620X2** = SPD for a 208/120V panelboard with a surge current capacity of 200kA per phase and Type 2 SPD.

When an option is not selected, include a **zero (0)** in the field.

Not available in 450, 550 or 750kA versions

SPD - Surge Protective Devices

TPS4 External or Wall Mounted SPDs

Selection

TPS4 09

TPS4 09 is a UL 1449 5th edition 130 kA Type 1 compact multi-mode surge protective device that can be installed on either the line or load side of the electrical service. When installed at the electrical service entrance, it can be used for UL 96A compliance (@ 20 kA I_n).

TPS4 09 Key Features

- UL 1449 5th edition Listed Type 1
- Type 1 Rated SPD
- 130 kA Per Phase Surge Current
- 20 kA I_n (most models)
- 200 kA SCCR
- UL 96A Lightning Protection Master Labeling compliant (@ 20 kA)
- Every MOV is monitored, including N-G
- Mounts external to electrical distribution equipment – weatherproof hub included
- Standard compact NEMA 4X polycarbonate enclosure
- Modes of Protection: L-N, L-G, N-G, and L-L
- Standard Monitoring: LED Indicators
- Wire Size: Prewired with 3' (91.4 cm) of #10 AWG
- Dimensions: 5.02" x 2.93" x 3.25"
- Weight: 1 lb.
- 10-year product warranty

Available Options:

- Dry contacts & audible alarm (option "D")



TPS4 09

Ordering Information

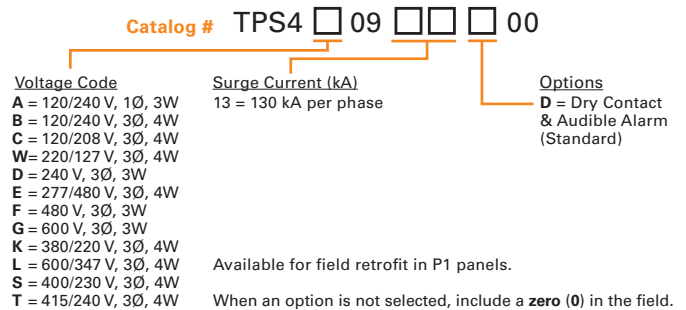

SPD - Surge Protective Devices

TPS4 External or Wall Mounted SPDs NEW

Selection

TPS4 11

TPS4 11 is a UL 1449 5th edition Listed multi-mode Type 1 surge protective device with a per phase surge current capacity that can be increased to 200 kA. In addition, this unit provides UL 1283 listed EMI/RFI or Sine Wave tracking filtering that will condition low energy L-N coupled noise. When installed at the electrical service entrance, it can be used for UL 96A compliance (@ 20 kA I_n).

Standard monitoring includes protection status indication LEDs. Complete protection is intact when the status indicators are illuminated. When protection is lost, the status indicator will extinguish and the red service light will illuminate. An audible alarm and dry contacts are available monitoring options.

A new diagnostic feature integrated within the TPS4 11 is Ground Integrity Monitoring or (GIM) diagnostic indication circuit. Ground Integrity Monitoring or (GIM) diagnostics monitors the health of the electrical system's neutral to ground bond. If voltage is seen across neutral and ground, the phase indicators will remain illuminated, while the red service light begins to flash alerting the end user that the electrical system grounding needs to be checked and serviced. This feature can be remotely monitored when the optional dry contacts are included. Siemens TPS4s are one of the first in the industry to offer this power quality safety and performance indication.

TPS4 11 Key Features

- UL 1449-5 Type 2 SPD and UL 1283 Listed
 - Optional UL 1449 5th edition Listed Type 1
- Type 1 / Type 2 SPD
- 100, 150, 200 and 250 kA Per Phase Surge Current
- 20 kA I_n
- 200 kA SCCR (most models)
- UL 96A Lightning Protection Master Labeling compliant (@ 20 kA)
- Every MOV is monitored, including N-G
- Mounts external to electrical distribution equipment
- Standard NEMA 4X polycarbonate enclosure (UL 746C (f1), UL 94-5VA)
- Modes of Protection: L-N, L-G, N-G, and L-L
- Standard Monitoring: LED Indicators and Ground Integrity Monitoring diagnostics
- Wire size: #8 AWG to #10 AWG
- Dimensions: 6.88" x 6.88" x 2.96"
- Weight: 3.5 lb.
- 10-year product warranty

Available Options:

- Dry contacts & audible alarm (option "D")



TPS4 11

Ordering Information

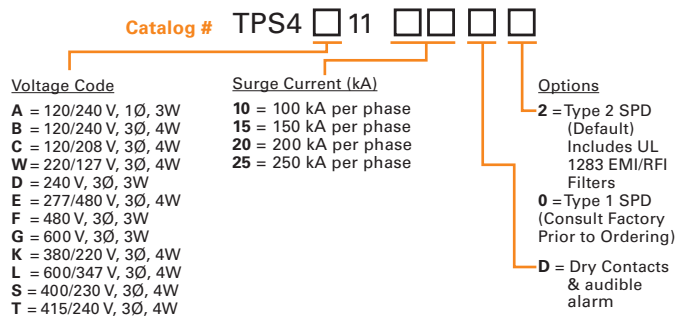

SPD - Surge Protective Devices

TPS4 External SPDs NEW

Selection

TPS4 12 and TPS4 L12 (True or Discrete 10-Mode)

TPS4 12 and TPS4 L12 are UL 1449-5 Type 2 and Optional UL 1449 5th edition surge protective device with a per phase surge current capacity that can be increased to 500 kA (TPS4 L12 up to 750 kA). For mission critical or high profile applications, the TPS4 L12 is our "True" or "Discrete" 10-mode style SPD providing the "Just in Case" assurance of directly connected L-L MOVs.

Both TPS4 12 and TPS4 L12 are UL 1283 Listed incorporating EMI/RFI or Sine Wave tracking filtering designed to condition low energy L-N coupled noise. When installed at the electrical service entrance, it can be used for UL 96A compliance (@ 20 kA In).

Standard monitoring includes protection status indication LEDs, audible alarm, and dry contacts. Complete protection is intact when the status indicators are illuminated. When protection is lost, the status indicator will extinguish, the red service light will illuminate, and the dry contacts will change state. An optional surge counter is available.

A new diagnostic feature integrated within the TPS4 12 and TPS4 L12 is Ground Integrity Monitoring or (GIM) diagnostic indication circuit. Ground Integrity Monitoring or (GIM) diagnostics monitors the health of the electrical system's neutral to ground bond. If voltage is seen across neutral and ground, the phase indicators will remain illuminated, while the red service light begins to flash alerting the end user that the electrical system grounding needs to be checked and serviced. This feature can be remotely monitored via the dry contact outputs. Siemens TPSs are one of the first in the industry to offer this power quality safety and performance indication.

TPS4 12 and TPS4 L12 Key Features

- UL 1449-5 Type 2 SPD and UL 1283 Listed
 - Optional UL 1449 5th edition Listed Type 1
- Type 1 /Type 2 SPD
- TPS4 12: 100 – 500 kA Per Phase Surge Current
- TPS4 L12: 150, 300, 450, 550, 750 kA Phase Surge Current
- 20 kA I_n (most models)
- 200 kA SCCR (most models)
- UL 96A Lightning Protection Master Labeling compliant (@ 20 kA)
- Every MOV is monitored, including N-G
- Mounts external to electrical distribution equipment
 - Recommended for line side or load side applications
- Standard NEMA 1/12/3R/04 ANSI 61 steel enclosure
- TPS4 12 Modes of Protection – L-N, L-G, N-G, and L-L
- TPS4 L12 Modes of Protection – L-N, L-G, N-G, and L-L (directly connected L-L elements)
- Standard Monitoring:
 - LED Indicators
 - Ground Integrity Monitoring diagnostics
 - Dry contacts
 - Event counter with time and date stamp
 - Audible alarm with silence switch and test button
- Wire size: #8 AWG to 1/0
- Dim: 12" x 12" x 8.5" (305 mm x 305 mm x 216 mm)[Ⓢ]
- Weight: 16.5 lbs (7484 g)[Ⓢ]
- 10-year product warranty

Available Options:

- Internal rotary disconnect
- Thru-door disconnect
- Flush kits available as accessory



Ordering Information

Catalog # **TPS4** 12 X

Voltage Code	Surge Current (kA)	Enclosure
A = 240/120 V, 1Ø, 3W	10 = 100 kA per phase	0 = Standard NEMA 4 metallic
B = 240/120 V, 3Ø, 4W	15 = 150 kA per phase	S = NEMA 4X stainless steel
C = 208/120 V, 3Ø, 4W	20 = 200 kA per phase	V = NEMA 4X non-metallic
W = 220/127 V, 3Ø, 4W	25 = 250 kA per phase	Options 1 alpha numeric character
D = 240 V, 3Ø, 3W	30 = 300 kA per phase	X = Surge counter (standard)
E = 480/277 V, 3Ø, 4W	40 = 400 kA per phase	
F = 480 V, 3Ø, 3W	50 = 500 kA per phase	
G = 600 V, 3Ø, 3W		D = Internal disconnect (default)
K = 380/220 V, 3Ø, 4W		T = Thru-door disconnect
L = 600/347 V, 3Ø, 4W		
S = 400/230 V, 3Ø, 4W		2 = Type 2 SPD (default) includes UL 1283 EMI/RFI Filters
T = 415/240 V, 3Ø, 4W		0 = NEMA 4X stainless steel

Example: **TPS4C12200XD2** = a Type 2 SPD for a 208/120V application with a surge current capacity of 200kA per phase, in a standard NEMA 4 enclosure with a surge counter and internal rotary disconnect option.

Not available in 300, 400 or 500kA
Can also be used on 208Y/120V 1Ø, 3W System

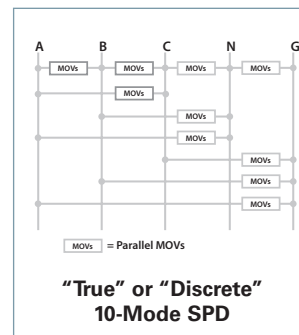

Ordering Information

Catalog # **TPS4** L12 X

Voltage Code	Surge Current (kA)	Enclosure
A = 240/120 V, 1Ø, 3W [Ⓢ]	10 = 100 kA per phase	0 = Standard NEMA 4 metallic
B = 240/120 V, 3Ø, 4W	30 = 300 kA per phase	S = NEMA 4X stainless steel
C = 208/120 V, 3Ø, 4W	45 = 450 kA per phase	V = NEMA 4X non-metallic
W = 220/127 V, 3Ø, 4W	55 = 550 kA per phase	Options 1 alpha numeric character
E = 480/277 V, 3Ø, 3W	75 = 750 kA per phase	X = Surge counter (standard)
K = 380/220 V, 3Ø, 4W		
L = 600/347 V, 3Ø, 4W [Ⓢ]		D = Internal disconnect (default)
S = 400/230 V, 3Ø, 4W		T = Thru-door disconnect
T = 415/240 V, 3Ø, 4W		

2 = Type 2 SPD (default) includes UL 1283 EMI/RFI Filters
0 = NEMA 4X stainless steel

Example: **TPS4CL12300XT2** = a Type 2 SPD for a 208/120V application with a surge current capacity of 300kA per phase, in a standard NEMA 4 enclosure with a surge counter and thru-door disconnect.

[Ⓢ] Not available in 450, 550 or 750kA
[Ⓣ] Can also be used on 208Y/120V 1Ø, 3W System
[Ⓤ] Internal disconnect options and other NEMA ratings may increase enclosure size and weight

SPD - Surge Protective Devices

TPS4 External or Wall Mounted SPDs NEW

Selection

TPS4 13

TPS4 13 is an UL 1449-5 Type 2 and Optional UL 1449 5th edition surge protective device with a per phase surge current capacity that can be increased to 400 kA.

TPS4 13 is UL 1283 Listed incorporating EMI/RFI or Sine Wave tracking filtering designed to condition low energy L-N coupled noise. When installed at the electrical service entrance, it can be used for UL 96A compliance (@ 20 kA In).

Standard monitoring includes protection status indication LEDs, audible alarm, and dry contacts. Complete protection is intact when the status indicators are illuminated. When protection is lost, the status indicator will extinguish, the red service light will illuminate, and the dry contacts will change state. A standard surge counter is included with time/date stamp.

TPS4 13 Key Features

- UL 1449-5 Type 2 SPD and UL 1283 Listed
 - Optional UL 1449 5th edition Listed Type 1
- Type 1 / Type 2 SPD
- TPS4 13: 100 – 400 kA Per Phase Surge Current
- 20 kA I_n
- 200 kA SCCR
- UL 96A Lightning Protection Master Labeling compliant (@ 20 kA)
- Every MOV is monitored, including N-G
- Mounts external to electrical distribution equipment
 - Recommended for line side or load side applications
- NEMA 4 Aluminum enclosure
- TPS4 13 Modes of Protection – L-N, L-G, N-G, and L-L
- Standard Monitoring:
 - LED Indicators
 - Ground Integrity Monitoring diagnostics
 - Dry contacts
 - Audible alarm with silence switch and test button
- Pre-wired with #10 AWG
- Dimensions: 9.35" x 8.14" x 3.25"
- Weight: 5.4 lb.
- 10-year product warranty



TPS4 13

Ordering Information

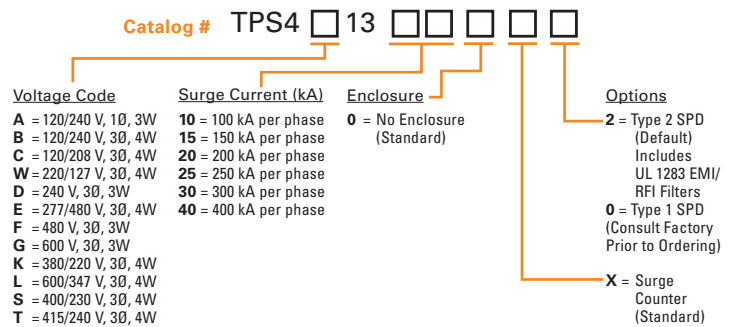

SPD - Surge Protective Devices

TPS4 External Mounted SPDs NEW

Selection

TPS4 15 and TPS4 L15 (True or Discrete 10-Mode)

TPS4 15 and TPS4 L15 are UL 1449-5 Type 2 and Optional UL 1449 5th edition surge protective device with a per phase surge current capacity that can be increased to 1000 kA (TPS4 L15 up to 900 kA). For mission critical or high profile applications, the TPS4 L15 is our "True" or "Discrete" 10-mode style SPD providing the "Just in Case" assurance of directly connected L-L MOVs.

Both TPS4 15 and TPS4 L15 are UL 1283 Listed incorporating EMI/RFI or Sine Wave tracking filtering designed to condition low energy L-N coupled noise. When installed at the electrical service entrance, it can be used for UL 96A compliance (@ 20 kA I_n).

Standard monitoring includes protection status indication LEDs, audible alarm, and dry contacts. Complete protection is intact when the status indicators are illuminated. When protection is lost, the status indicator will extinguish, the red service light will illuminate, and the dry contacts will change state. An optional surge counter is available.

A new diagnostic feature integrated within the TPS4 15 and TPS4 L15 is Ground Integrity Monitoring or (GIM) diagnostic indication circuit. Ground Integrity Monitoring or (GIM) diagnostics monitors the health of the electrical system's neutral to ground bond. If voltage is seen across neutral and ground, the phase indicators will remain illuminated, while the red service light begins to flash alerting the end user that the electrical system grounding needs to be checked and serviced. This feature can be remotely monitored via the dry contact outputs. Siemens TPSs are one of the first in the industry to offer this power quality safety and performance indication.

TPS4 15 and TPS4 L15 Key Features

- UL 1449-5 and UL 1283 Listed
 - Optional UL 1449 5th edition Listed Type 1
- Type 1 / Type 2 SPD
- TPS4 15: 400 – 1000 kA Per Phase Surge Current
- TPS4 L15: 600 and 900 kA Phase Surge Current
- 20 kA I_n (most models)
- 200 kA SCCR (most models)
- UL 96A Lightning Protection Master Labeling compliant (@ 20 kA)
- Every MOV is monitored, including N-G
- Mounts external to electrical distribution equipment
 - Recommended for line side or load side applications
- Standard NEMA 1/12/3R/04 ANSI 61 steel enclosure
- TPS4 15 Modes of Protection – L-N, L-G, N-G, and L-L
- TPS4 L15 Modes of Protection – L-N, L-G, N-G, and L-L (directly connected L-L elements)
- Internal rotary disconnect switch included
- Standard Monitoring:
 - LED Indicators
 - Ground Integrity Monitoring diagnostics
 - Dry Contacts
 - Audible alarm with silence switch and test button
 - Event counter with time and date stamp
- Wire size: #8 AWG to 1/0
- Dimensions: 12" x 12" x 8.5" (305 mm x 305 mm x 216 mm)
- Weight: 24.5 lb. (11,113 g)
- 10-year product warranty
- Thru-door disconnect (default)

Available Options:

- Flush kits available as accessory



Ordering Information

Catalog # TPS4 15 X

Voltage Code	Surge Current (kA)	Enclosure
A = 240/120 V, 1Ø, 3W ^①	60 = 300 kA per phase	0 = Standard NEMA 4 metallic
B = 240/120 V, 3Ø, 4W	80 = 400 kA per phase	S = NEMA 4X stainless steel
C = 208/120 V, 3Ø, 4W	1K = 1000 kA per phase	V = NEMA 4X non-metallic
W = 220/127 V, 3Ø, 4W		Options 1 alpha numeric character
D = 240 V, 3Ø, 3W		X = Surge counter (standard)
E = 480/277 V, 3Ø, 4W		T = Thru-door disconnect (default)
F = 480 V, 3Ø, 3W		2 = Type 2 SPD (default) includes UL 1283 EMI/RFI Filters
G = 600 V, 3Ø, 3W		0 = NEMA 4X stainless steel
K = 380/220 V, 3Ø, 4W		
L = 600/347 V, 3Ø, 4W		
S = 400/230 V, 3Ø, 4W		
T = 415/240 V, 3Ø, 4W		

Example: **TPS4C15800XT2** = a Type 2 SPD for a 208/120V application with a surge current capacity of 800kA per phase, in a standard NEMA 4 enclosure with a surge counter and thru-door disconnect.

^① Can also be used on 208Y/120V 1Ø, 3W System

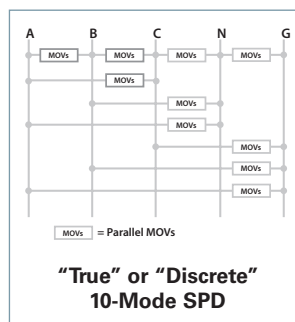

Ordering Information

Catalog # TPS4 L15 X

Voltage Code	Surge Current (kA)	Enclosure
A = 240/120 V, 1Ø, 3W ^①	60 = 600 kA per phase	0 = Standard NEMA 4 metallic
B = 240/120 V, 3Ø, 4W	90 = 900 kA per phase	S = NEMA 4X stainless steel
C = 208/120 V, 3Ø, 4W		V = NEMA 4X non-metallic
W = 220/127 V, 3Ø, 4W		Options 1 alpha numeric character
E = 480/277 V, 3Ø, 3W		X = Surge counter (standard)
K = 380/220 V, 3Ø, 4W		T = Thru-door disconnect (default)
L = 600/347 V, 3Ø, 4W		2 = Type 2 SPD (default) includes UL 1283 EMI/RFI Filters
S = 400/230 V, 3Ø, 4W		0 = NEMA 4X stainless steel
T = 415/240 V, 3Ø, 4W		

Example: **TPS4CL15900XT2** = a Type 2 SPD for a 208/120V application with a surge current capacity of 900kA per phase, in a standard NEMA 4 enclosure with a surge counter and thru-door disconnect.

^① Can also be used on 208Y/120V 1Ø, 3W System

^② Other NEMA ratings may increase enclosure size and weight.

SPD - Surge Protective Devices

Surge Protective Devices

FAQ

Frequently Asked Questions

What is a surge protective device or SPD?

A Surge Protective Device is a device that attenuates (reduces in magnitude) random, high energy, short duration overvoltages caused by lightning, utilities, switching, etc. Such anomalies occur in the form of voltage and current spikes with a duration of less than half an ac voltage cycle. These high energy power spikes can damage sensitive electronic equipment, such as computers, instrumentation, and process controllers.

How do SPDs work?

Surge suppressors divert high energy power away from a load by providing a lower impedance path to common point earth ground. This is similar in concept to pressure relief valves that protect water heaters from overpressure. Surge suppressors used most often for protection of AC power have metal oxide varistors (MOVs) connected in parallel.

Where are SPDs installed?

AC voltage surge suppressors are typically installed in these three areas: at a utility service entrance for protection of an entire facility, in distribution panelboards and switchboards for protection of sensitive downstream loads; connected to a wall outlet for individual protection of a specific piece of equipment, such as a computer or solid-state controller.

What is clamping voltage?

Clamping voltage, also referred to as peak let through or suppressed voltage rating, is the amount of voltage a surge suppressor permits to pass through it to the attached load during a transient event. Clamping voltage is a performance measurement of a surge suppressor's ability to attenuate a transient. For example, a surge suppressor might limit a 6,000V surge so that only 700V is 'visible' to the load. The Voltage Protection Rating is 700V, commonly called Clamping Voltage. This performance value is confirmed by Underwriters Laboratories during tests conducted while evaluating a surge suppressor for listing.

What is surge current capacity?

Surge current capacity is the maximum amount of surge current that a surge suppressor can pass for a single transient event. This level is used to indicate the protection capacity of a particular surge suppressor design, and when specifying surge suppressors. For example, in a high exposure application with very large transients present from lightning, a higher level surge current capacity might be desired. Be aware that surges have natural limitations and that larger surge current capacity tends to add redundancy rather than the implied ability to handle an extremely large surge. For example, an entire lightning strike cannot go through wire; it is much like trying to put the output from a fire hose through a soda straw. Consequently, suppressors do not need to be sized for entire lightning strikes. There are valid reasons for adding excess surge current capacity for redundancy reasons.

What types of components make up a SPD?

The device most commonly used in AC voltage surge suppressors are MOVs, a solid-state device made of zinc oxide materials. MOVs are voltage sensitive semiconductors, which change from high impedance to low impedance when sensing an overvoltage condition. MOVs are packaged for specific voltages and current handling capacities. Other devices (more typically found in DC applications) include single junction diodes and gas tubes that ionize at preset voltages.

What features should be considered when selecting SPDs?

Two important areas to consider during the selection of a surge suppressor are performance and safety, and include the following criteria: Performance: 1) surge current capacity; and 2) clamping voltage. Safety: 1) the individual suppression circuit should be fused to clear an inoperative MOV during an extreme transient event, and 2) provide overcurrent protection for the surge suppressor during a fault condition.

What surge current capacity is required?

Surge current capacity is dependent on the application and the amount of required protection. The selection of the proper surge suppressor is not an exact science and cannot be scientifically calculated from a standard algorithm.

Questions to consider when specifying the proper surge current capacity for a surge suppressor include:

- What is the geographic location of the facility and it's susceptibility to lightning? (For example, Ontario is a high-lightning area; Prince Edward Island is a low lightning area.)
- Is the facility in a rural or urban setting?
- Is the facility the tallest building around?
- Is the facility at the end of the utility grid?
- If it is an existing facility, what is its power quality history?

Based on the above information, and taking into account the cost of protection, the following is a good rule of thumb: a surge suppressor with a surge current capacity in the range of 100kA to 300kA would be used in conjunction with a service entrance panelboard or switchboard. A surge suppressor with a surge current capacity in the range of 100kA to 200kA would be used in conjunction with a downstream panelboard