

SIEMENS

Ingenuity for life

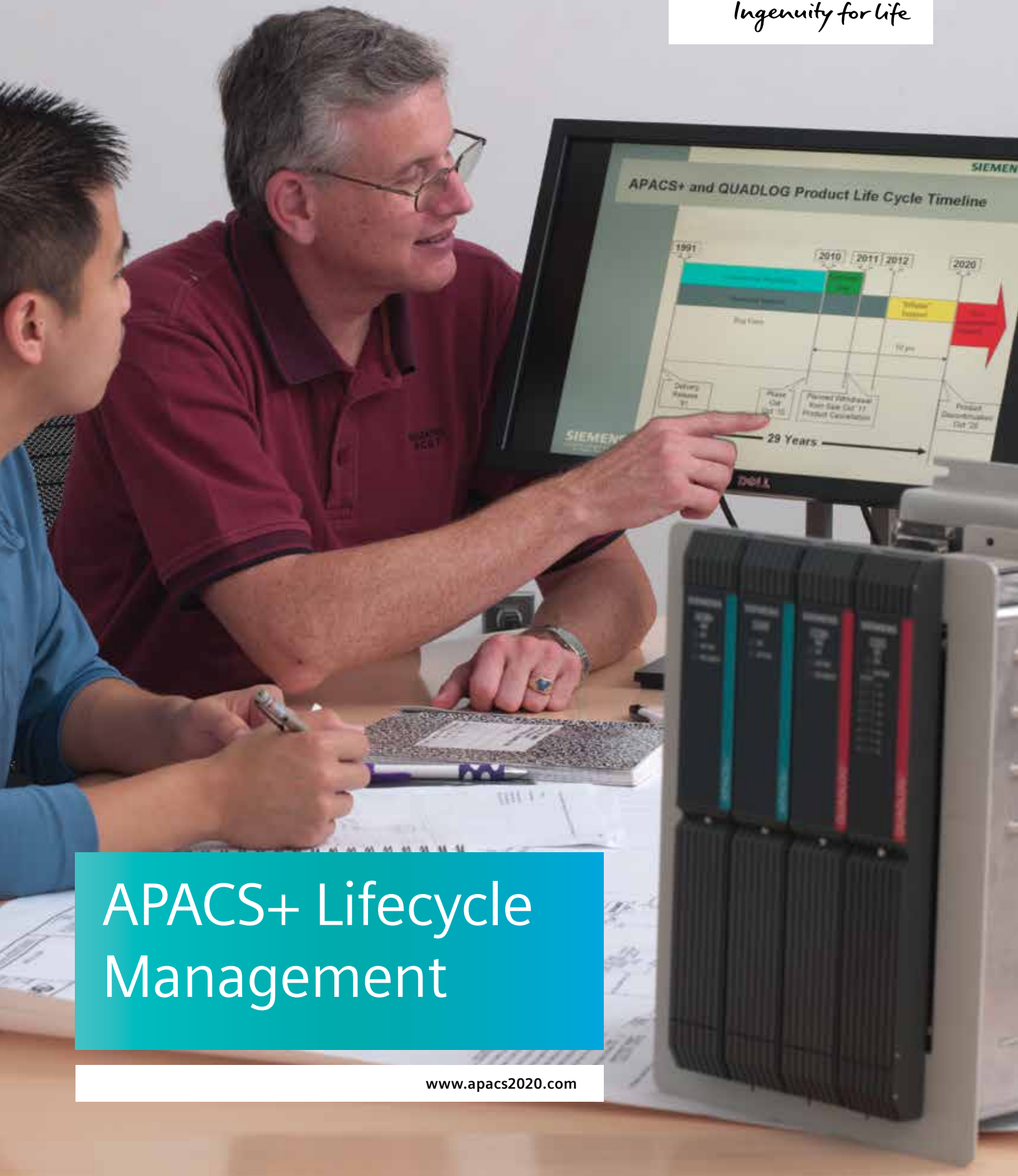

SIEMENS
APACS+ and QUADLOG Product Life Cycle Timeline

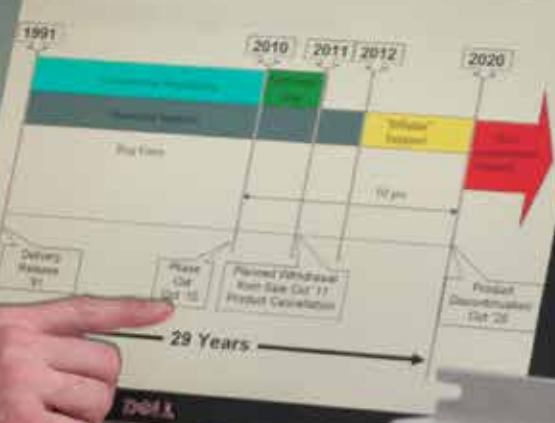

APACS+ Lifecycle Management

www.apacs2020.com

Continued support of your APACS+ while introducing personalized pathways to meet your future automation needs.

Since 1991 the Spring House, Pennsylvania team has supported the APACS+ DCS and we continue to design, manufacture, sell and support the system in-house. We continue to provide newly manufactured APACS+ spare parts from our factory and guaranteed hotline support until 2020.

The engineering staff of both the Siemens in-house and field service teams along with our certified solution partners bring decades of experience to help you support your systems. We consistently work with our process automation user community customers to get their input on our products. Their feedback on solutions influences our product development, and in the case of the SIMATIC PCS 7 their guidance was to not only capture the key elements of the APACS+ system, including the configuration library, but also to develop new and innovative solutions. These tools help you reduce the need for customization, while improving safety and security and enhancing the user experience, all while reducing the installed and lifecycle costs as compared to other systems.

Modernization Options

This document will explain the different migration options available for your APACS+ solution. Each path was developed by our expert process automation engineers that have a deep understanding for the APACS+ solution, because they created it! We developed tools to bulk migrate your graphics, run your new HMI simultaneously as your existing system online, convert your IO in seconds and effortlessly interpret your 4-mation configuration (*.mbr), document it to support the automated conversion of your 4-mation code. This enables you to preserve your intellectual property while minimizing your effort to modernize your control strategies.

Graphic Conversion Service

Our tool based solution, created by our Spring House, Pennsylvania team can convert your APACS+ legacy graphics (e.g. ProcessSuite/Wonderware, APS) and load them onto the new PCS 7 OS for you. This increases operator acceptance and lowers transition costs.

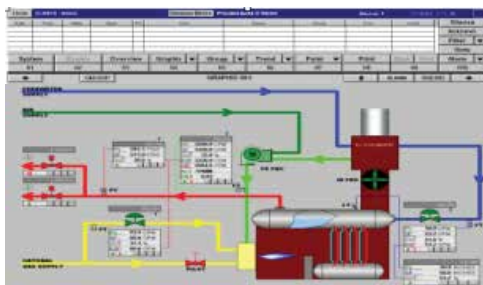

HMI-x Graphic

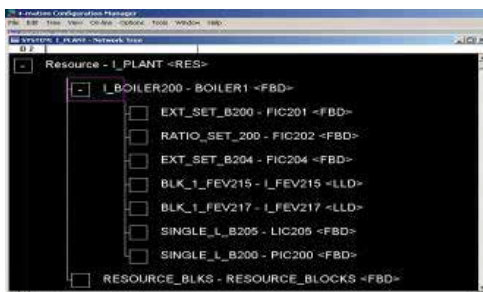

Controller-x Configuration

Conversion Service



Static Elements

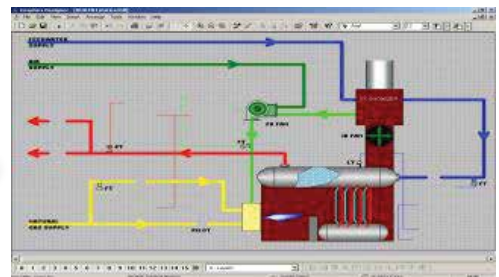

Database Automation



Merges the Dynamic & Static Elements

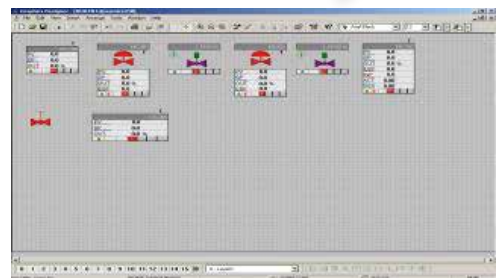

Dynamic Elements (Symbols)



As your trusted partner over the past three decades, we understand your process control needs and the support you've grown accustomed to.

Operator Station Migration

Modernize your Operator Stations (OS) online without an interruption to production and while still operating your existing legacy HMI system. This will provide your operators with the time to get acclimated to the new system. Since 2003, the PCS 7 APACS+ OS DCS HMI upgrade has helped users extend the life of their installed APACS+ system while improving their experience.

Enhancements with PCS 7 OS HMI

Once you create the basic overview graphics you can enhance your visualization with Advanced Process Graphics (APG). This will help you to identify and operate within your KPIs, increasing safety and profitability.

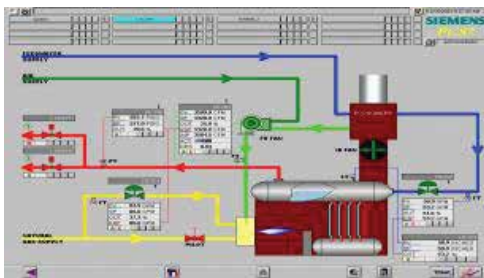

PCS 7 OS Graphic (.pdl)

Improvements with OS HMI:

- Faster & Personalized Navigation so operators can create, save for later and recall screen views showing; trends, multiple graphics, faceplates, and alarm views to support plant operations.
- Alarm Management tools to meet ISA S18.02 including alarm statistics to identify problems and deploy strategies (suppress, hide, shelve...) to reduce the number of alarms an operator needs to respond to.
- Industrial Cyber Security compliance
- Windows, Web Clients, Web UX or Virtualized Architectures
- OPC Connectivity included
- Integrated Process Historian and Reporting
- One vendor solution with optimized connectivity between 4-mation and the HMI where the symbols are automatically generated and linked to the appropriate controller object (motor, valve, loop), and placed onto the appropriate graphic.

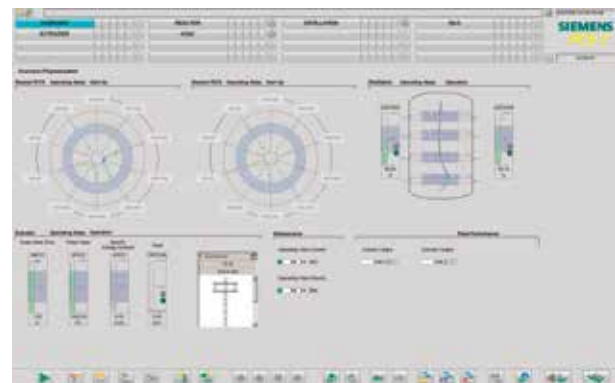

PCS 7 APG Spider Diagram



PCS 7 APG Distillation Column

Enhancements with PCS 7 System Architecture

You may have found with APACS+ that controller capacity, single scan rate and remote IO integration require extra planning. As your automation demands increase consider PCS 7. Below is a comparison of the two systems architectures:

- PCS 7 Controller provides for a larger capacity (48 MB vs 8 MB)
- More flexibility (multiple scan rates as fast as 10ms vs. a single scan rate) for your logic and IO
- Global standards based communications (Ethernet on-board with high speed fieldbus networks for electrical, instrument and IO vs slow proprietary networks).

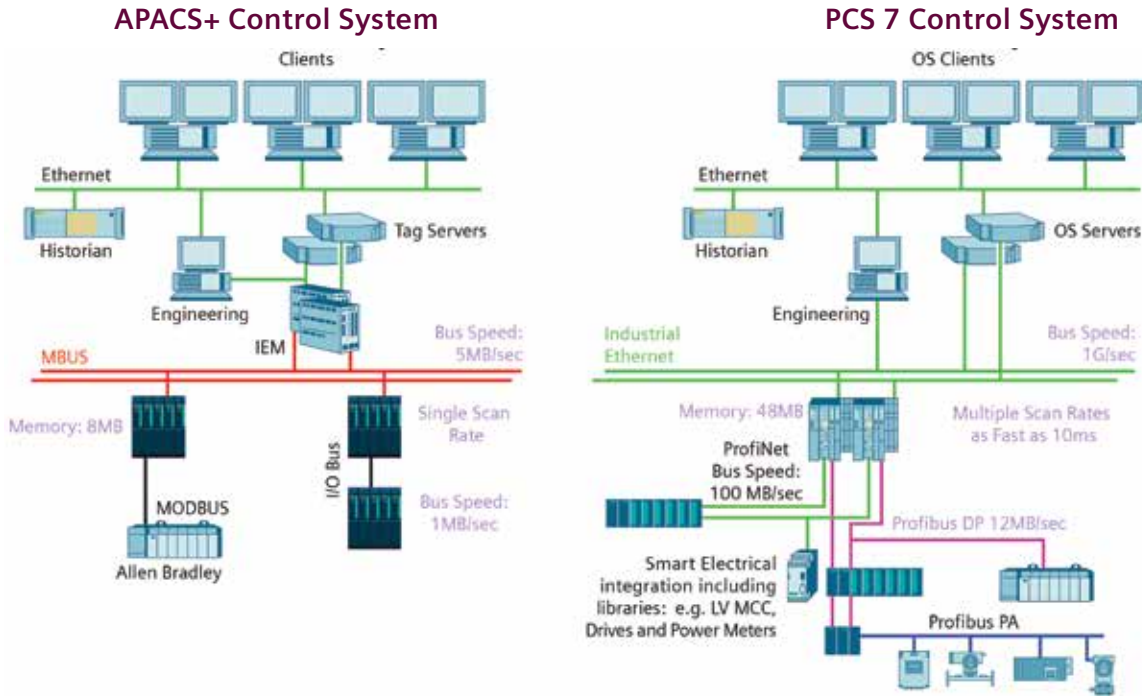

Stepwise Adoption of PCS 7

As your automation needs increase, consider investing in your future with a PCS 7 controller. You will have a common HMI for the APACS+ and PCS 7 systems helping with operator adoption. The PCS 7 and APACS+ ACM controller will talk peer-to-peer via Ethernet and you will already have the core PCS 7 configuration tools as they are included in your PCS 7 APACS+ OS HMI software bundle. Cost-effective, seamless adoption by operations and a building block towards the future is what this offers.

APACS+ / PCS 7 Integrated Architecture

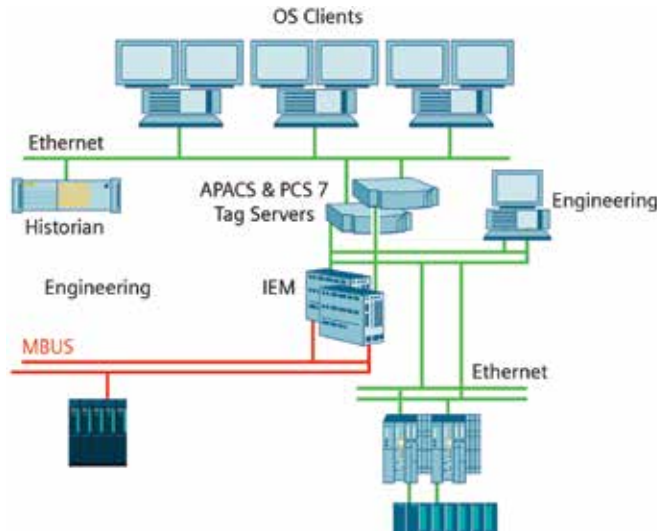

Controller Code Conversion Strategy

The AS Migration Studio captures and documents your 4-mation code, including soft list parameters, saving time and money while reducing risk as you modernize to PCS 7. The PCS 7 system Advanced Process Library provides you the best form, fit and function replacement for your APACS+ 4-mation code – example above for the PID Controller migration, while improving your future automation experience.

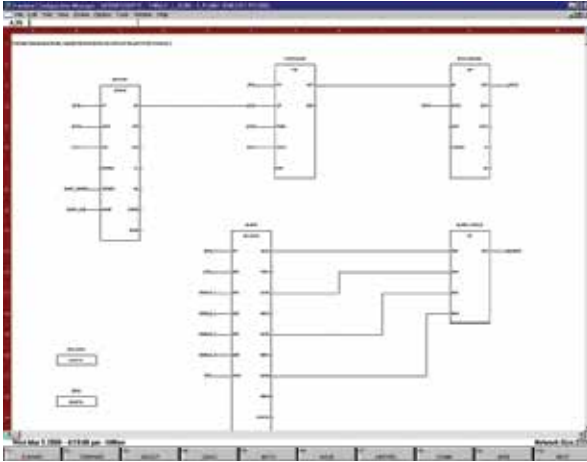

APACS+ PID Block

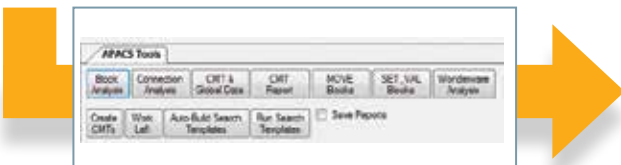
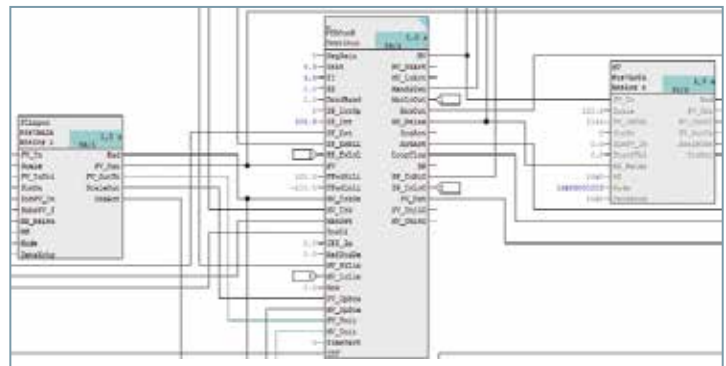

The AS Migration Studio performs the conversion analysis using pattern recognition producing modern control strategies that leverage the features of PCS 7.

PCS 7 PID Block which captures all the elements of the APACS+ block can also control performance monitoring and loop tuning tools. The PCS 7 library also includes an embedded model predictive controller (MPC).

PCS 7 Improvements over APACS+

Now that you are using the native PCS 7 libraries, you can efficiently visualize key process data including interlocks, first-out, sequences, control loop performance, asset management and model predictive control.



Auto configured asset management provides color coded status information.

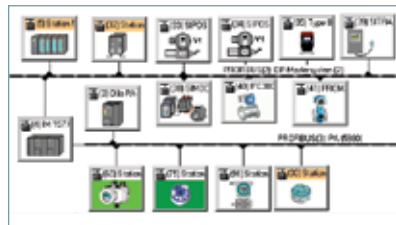

Graphical configuration for your IO, computer networks, electrical and instrumentation assets.

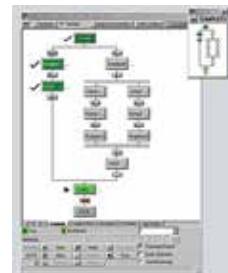

Automatic visualization of sequences in the HMI empower operators to reduce cycle times.



The Logic Matrix simplifies the engineering and operational visibility of interlocking logic based on the cause-effect principal including first-out and interlock navigation.

APACS+ MTA termination migration to PCS 7 IO.



APACS+ universal cabling solution:

A perfect molded fit to the existing MTA connectors and connecting to your new IO, keeps the existing field wiring in place and allows for cutover to the new IO in seconds:

- 3 Meter
- 8 Meter
- 15 Meter
- 30 Meter

No field IO wires lifted, a universal cable with perfect connection to the APACS+ MTA's, field cutover in seconds to new IO is what this solution offers.

The Siemens MTA cable is offered in 3, 8, 15 and 30 meter lengths with a perfectly matched connection to your MTA and the option for direct connection or via terminal strips (with fusing) to your new PCS 7 IO card. We can further simplify the connection between the PCS 7 IO card and the terminal strip with a pre-assembled, tested and labeled TOP connect wiring/termination offering. This can also include updated drawings.

The new IO and termination assemblies are designed and tested offsite to be an optimized fit for your installation. In this example we show a (32ch) 24V Standard Discrete Module (SDM) termination connected to a terminal strip and then a (16ch) DI and (16ch) DO PCS 7 ET200M IO cards on the left side of the rail. The bottom (32ch) Standard Analog Module (SAM) is wired directly to the two (8ch) AI and two (8ch) AO PCS 7 ET200M cards on the right side of the top rail. The SAM module did not support HART, whereas the PCS 7 ET200M IO modules can. This now gives you easy access to the extended data and diagnostics provided from HART.

To cutover your system, just install your new IO panels onsite and the APACS+ termination MTA cabling migration takes seconds – just remove the old MTA connector to the APACS+ module and install the pretested and new MTA cable to your existing APACS+ MTA – thus connecting to your new IO – no field wiring touched – 32 channels migrated in seconds.

Spare parts options

Siemens wants to keep your control systems stable. If you're undecided about when to upgrade your APACS+ process control system or QUADLOG safety system during the coming years, Siemens still offers in-house manufactured, new spare parts to keep your plant up and running.

When maintaining a system like APACS+ for years to come, you may want to consider the following areas in order to optimize and improve your plant's process:

- System performance
- System capacity
- Key system components

Siemens offers products that can help you during this critical time.

Increase your system performance:

- Improve the performance of your M-NET network by upgrading to Ethernet, using an Industrial Ethernet Module (IEM).
- Improve the performance of your APACS+ controller, especially if you've changed the configuration in the last 20 years, with an upgraded CPU allowing for a faster scan rate, using an ACMx Module (or CCMx for your QUADLOG safety system).

Increase your system capacity:

- If you've increased the size of your configuration in the last 20 years, you may want to think about more memory. Not only does the new ACMx module have more memory than previous versions, the overhead code needs less of it, thereby freeing up the extra memory for your configuration. The extra memory can be used to support your larger configuration or expanded I/O capacity.
- Before deciding on a migration path forward, you may need to expand your plant. New APACS+ or QUADLOG I/O modules are available for the new process area in your plant.
- When adding a new area to the plant, you may require more than just I/O modules. Whole integrated APACS+ controllers (Racks, ACMx, Power Supplies and I/O) are also available. These can help you automate the remaining process area for years to come before you decide to migrate.

Refresh your key system components:

- One of the key components of your APACS+ system is the 4-mation software, used for re-configuring the controller or to reset parameters and other values. If you're running on XP or older PCs, stay secure and move up to a Windows 7 version of the "Control CD." This CD comes with 4-mation for Windows 7 as well as other utilities to keep your system fresh for the next decade.
- Other components like power supplies, Modulrac fan assemblies, and batteries wear out over time. Start thinking about refreshing them in order to keep your system running reliably.

To the right is a list of the spare parts that are available. Speak to your Siemens Process Account Manager or Siemens Certified Solution Partner about a full list and pricing for the APACS+ or QUADLOG components available.

APACS+ Software	
UPH:PS032011V70	APACS+ Control Engineering/Development Station V7.0 SP1 (4-mation on Windows 7)
UPH:PS032303V70U	APACS+ V7.0 Control Update Kit (Update to 4-mation on Windows 7)

APACS+ Controllers	
UPH:39ACM24BEN	ACM+ Advanced Control Module Plus - 4MB - APACS+
UPH:39ACM34AAN	ACMx eXcelerated Advanced Control Module - 4MEG - APACS+
UPH:39ACM38AAN	ACMx eXcelerated Advanced Control Module - 8MEG - APACS+

APACS+ I/O Modules	
UPH:39EAMCBN	Enhanced Analog Module - APACS+
UPH:39IDM115ACCBN	Input Discrete Module - APACS+
UPH:39MBXNAN	Modulbus Expander Module - APACS+
UPH:39RTMCAN	Resistance Temperature Module - APACS+
UPH:39SAIAAN	Standard Analog Input Module - APACS+
UPH:39SAMCAN	Standard Analog Module - APACS+
UPH:39SDM024DCCBN	Standard Discrete Module -24V - APACS+
UPH:39SDM048DCCBN	Standard Discrete Module -48V - APACS+
UPH:39VIMCCN	Voltage Input Module - APACS+
UPH:39SCMNNAAN	Satellite Control Module - APACS+

QUADLOG Controllers	
UPH:QLCCM22AAN	CCM+ Critical Control Module Plus 2Meg - QUADLOG
UPH:QLCCM24AAN	CCM+ Critical Control Module Plus 4Meg - QUADLOG
UPH:QLCCM32AAN	CCMx eXcelerated Critical Control Module 2Meg - QUADLOG
UPH:QLCCM36AAN	CCMx eXcelerated Critical Control Module 6Meg - QUADLOG

QUADLOG I/O Modules	
UPH:QLCDM024DCBAN	Critical Discrete Module 24V - QUADLOG
UPH:QLCDM048DCBAN	Critical Discrete Module 48V - QUADLOG
UPH:QLCDODCAAN	Critical Discrete Output Module - QUADLOG
UPH:QLCAMAAN	Critical Analog Module - QUADLOG
UPH:QLEAMBBN	Enhanced Analog Module - QUADLOG
UPH:QLIDM115ACBBN	Discrete Input Module - QUADLOG
UPH:QLMBXNAN	Modulbus Expander Module - QUADLOG
UPH:QLRTMBAN	Resistance Temperature Module - QUADLOG
UPH:QLSAMBAN	Standard Analog Module - QUADLOG
UPH:QLSDM024DCCBN	Standard Discrete Module - QUADLOG
UPH:QLVIMBCN	Voltage Input Module - QUADLOG

Siemens Industry, Inc.
1201 Sumneytown Pike
Spring House, PA 19477

info.us@siemens.com
(800) 365-8766

Subject to changes without prior notice.
All rights reserved.
Order No: PABR-00095-0516
Printed in USA
© 2016 Siemens Industry, Inc.

Subject to changes and errors. The information given in this document only contains general descriptions and/or performance features which may not always specifically reflect those described, or which may undergo modification in the course of further development of the products. The requested performance features are binding only when they are expressly agreed upon in the concluded contract.

