

SIEMENS

Ingenuity for life



Breaker-and-a-half – Automatic reclosing and leader follower

www.siemens.com/siprotec

SIPROTEC 5 Application

Breaker-and-a-half – Automatic reclosing and leader follower

SIPROTEC 5 Application

Breaker-and-a-half – Automatic reclosing and leader follower

APN-018, Edition 1

Content

1	Breaker-and-a-half – Automatic reclosing and leader follower.....	3
1.1	Introduction.....	3
1.2	Overview	3
1.3	Automatic reclosing.....	5
1.4	Leader/Follower Logic.....	5
1.5	Conclusion.....	9

1 Breaker-and-a-half – Automatic reclosing and leader follower

1.1 Introduction

This application note provides describes a simple Leader/Follower logic for a breaker-and-a-half application using SIPROTEC 5.

Most of the logic described in this application note is preconfigured in the template “1 ½ Circuit Breaker”.

The applicable SIPROTEC 5 device Manual should be consulted for detailed information. The “Help” Function in DIGSI 5 as well as detailed application descriptions on various SIPROTEC 5 subjects can also be consulted.

1.2 Overview

The breaker-and-a-half configuration requires special attention with regard to the connection of the current transformers and the automatic reclosing scheme. With SIPROTEC 5 this is a simple matter as the application of multiple measuring points and circuit breakers is an integral part of the configuration of each device. This is best described with an example as provide in this application note.

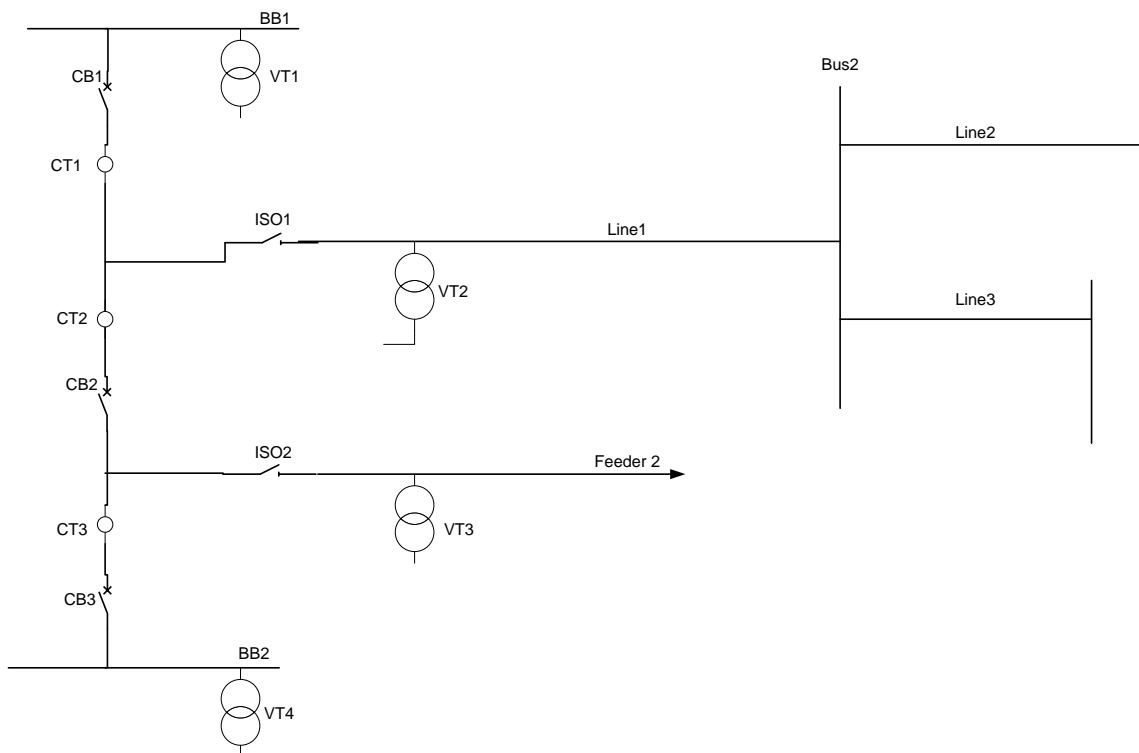

Figure 1: Single line diagram of protected feeder

SIPROTEC 5 Application

Breaker-and-a-half – Automatic reclosing and leader follower

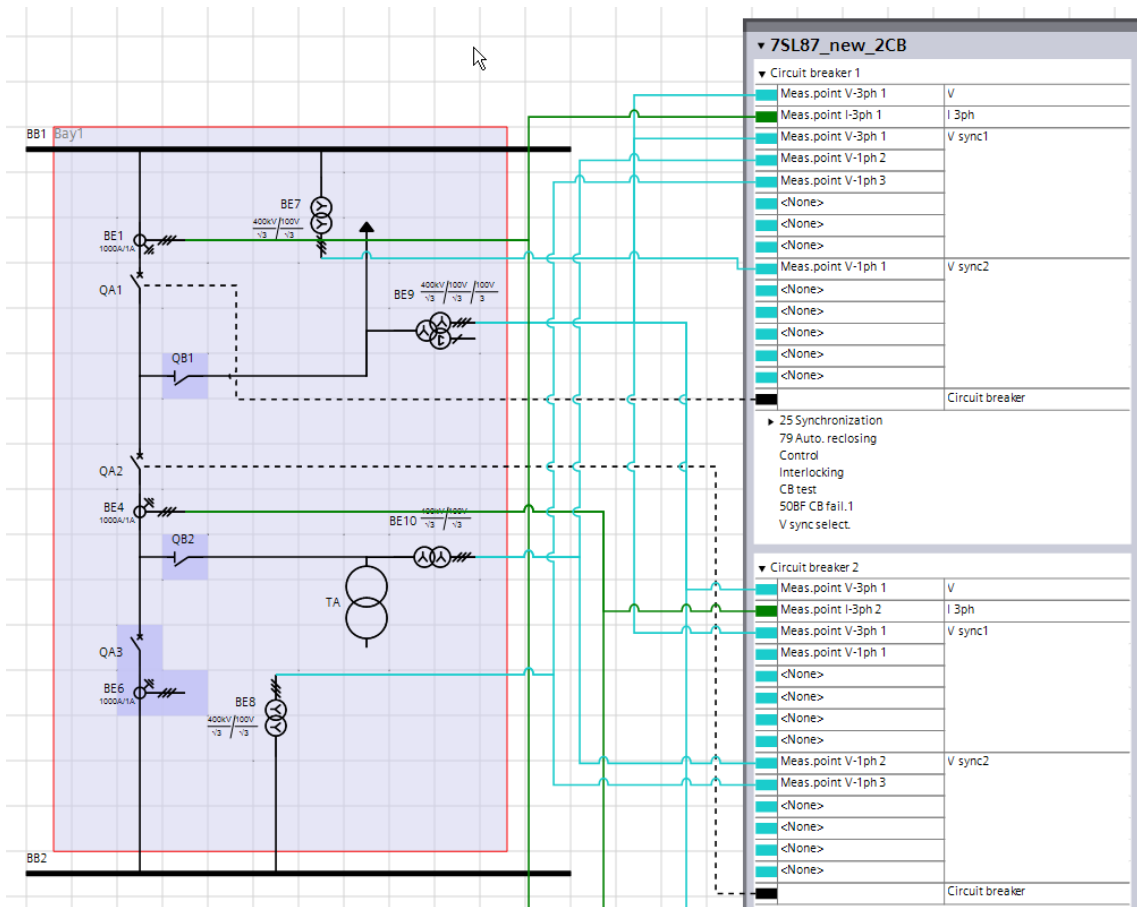

Figure 2: Allocation of CT's and VT's

The Single Line Editor shown in Figure 2 above is a useful tool for graphic assignment of measuring points and switch gear. The applied configuration should be confirmed in the Function Group connections shown below:

▼ Connect measuring points to function group

Measuring point	Line 1			Circuit breaker 1				Circuit breaker 2			
	V 3ph	I line 3ph	V	I 3ph	V sync1	V sync2	V	I 3ph	V sync1	V sync2	
(All...)	(All...)	(All...)	(...)	(All...)	(All...)	(All...)	(All...)	(All...)	(All...)	(All...)	
Meas.point V-3ph 1[ID 1]	X		X		X		X		X		
Meas.point V-1ph 1[ID 2]						X			X		
Meas.point V-1ph 2[ID 3]					X					X	
Meas.point I-3ph 1[ID 4]		X		X				X			
Meas.point I-3ph 2[ID 5]		X						X			
Meas.point V-1ph 3[ID 6]					X					X	

Figure 3: Allocation of measuring points to function groups

A Sync Check voltage is shown in the diagram above. This is only the case if the relevant FG Circuit Breaker contains a sync check function.

1.3 Automatic reclosing

The automatic reclosing function is located in the circuit breaker function groups. The initiation (start) and optional blocking of the automatic reclosing (AR) function is selected under “Circuit Breaker Interaction” as shown in Figure 4 below.

▼ Circuit-breaker interaction									
Protection group	Circuit breaker 1				Circuit breaker 2				
	Start auto.recl.	Blk. auto.recl.	Trip	Start CB failure	Start auto.recl.	Blk. auto.recl.	Trip	Start CB failure	
(All...)	(All...)	(All...)	(All...)	(All...)	(All...)	(All...)	(All...)	(All...)	(All...)
49 Th.overl. 1			X	X			X	X	
▶ 21 Distance prot. 1	X		X	X	X		X	X	
▶ 85-21 Perm. overr.	X		X	X	X		X	X	
▶ 85-67N Dir. comp.	X		X	X	X		X	X	
▶ Switch onto fault 1		X	X	X		X	X	X	
▶ 87 Line diff. prot.	X		X	X	X		X	X	
▶ Stub-fault prot. 1			X	X			X	X	
▶ 50/51 OC-3ph 1	X		X	X	X		X	X	
▶ 50N/51N OC-gnd 1	X		X	X	X		X	X	
▶ 50 OC high-speed 1			X	X			X	X	
▶ 67N GFP gnd.sys.1	X		X	X	X		X	X	
▶ 59 Overvolt.-3ph 1			X	X			X	X	
▶ 27 Undervolt.-3ph 1			X	X			X	X	
▶ 81 Overfreq.-A 1			X	X			X	X	
▶ 81 Underfreq.-A 1			X	X			X	X	
▶ External trip 1			X	X			X	X	

Figure 4: Circuit breaker interaction – selection of start and block of AR

In general all the selective protection functions will be configured to start the automatic reclosing function. In the example above the Switch onto fault function is selected to block the auto re-close function. This provides additional security against inadvertent re-closure following a switch onto fault condition.

Automatic reclosing is not required following a trip by voltage or frequency protection. A start by these functions is therefore not selected.

The selection for Circuit breaker 1 and 2 are identical.

1.4 Leader/Follower Logic

In the breaker-and-a-half application there is often a need to select a “Leader”. The Leader will perform the re-close with the AR function using the set dead time. The Follower will only perform a re-close when the Leader indicates that its reclosing was successful.

In this application a user defined Marker Command (CB1 is Leader) is provided to select which Circuit Breaker will assume the role of Leader. When the selection is “CB1 is Leader = ON”, the leader role will be taken on by Circuit Breaker 1. This can be reversed by executing a command via the Keypad, or other external source, to change to “CB1 is Leader = OFF”. Now the leader role will be taken on by Circuit Breaker 2.

SIPROTEC 5 Application

Breaker-and-a-half – Automatic reclosing and leader follower

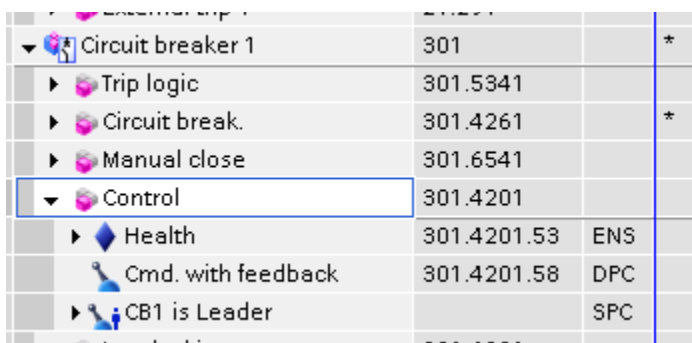

Figure 5: Marker Command “CB1 is Leader” for selection of Leader/Follower

After the initial start of the device the selection state of Marker Command CB1 is Leader is “ON”. The state may be changed at any time, e.g. by means of the “Control Menu” in the device display.

The required AR response is defined in the table below. The “Leader” circuit breaker is the CB1 when the Marker Command “CB1 is Leader” is “ON”. When it is “OFF” CB2 will be leader. The other breaker is designated as “Follower”:

Pre fault state		Description	AR response	
Leader	Follower		Leader	Follower
Close	Closed	Normal Operation with both CB closed prior to fault	Close with set dead time as Leader and then release Follower	Run normal dead time then wait for release by Leader before AR close
Close	Open	The Follower is open prior to fault	Close with set dead time as Leader and then release Follower	AR detects CB open and does not start = no AR close
Open	Closed	Leader is open prior to fault	AR detects CB open and does not start = no AR close	Close with set dead time as Leader does not block the Follower
Close	Closed	Normal Operation with both CB closed prior to fault – AR not successful – permanent fault	Close with set dead time - Trip – definite trip no further AR	Run normal dead time then wait – no release by Leader – no AR and definite trip

Table 1

A simple logic is applied in the Function charts to achieve the above response:

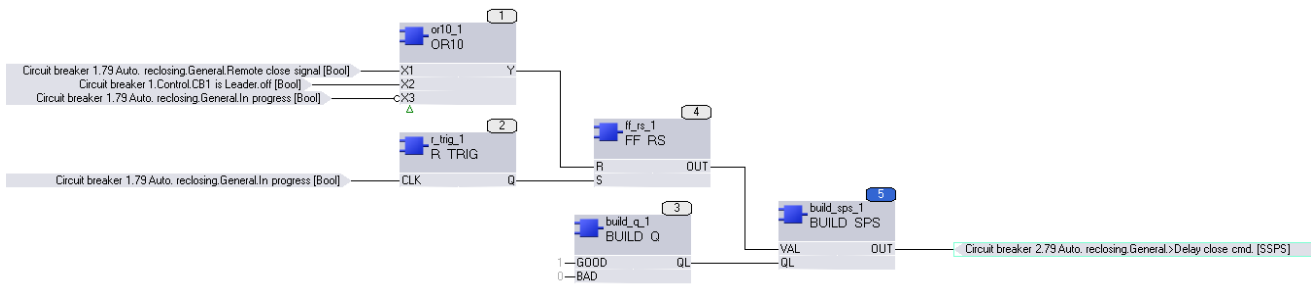

Figure 6: CFC Logic to delay Follower Re-Close command (CB1 is Leader)

The above logic is implemented in the Function Charts. Shown is only the Logic that applies when CB1 is leader. A further logic with the same structure exists in parallel; it applies when CB2 is leader.

In the above logic, the Flip-Flop can only be set when CB1 is Leader equals "ON". If this is not the case the input X2 of OR10 is "true" and therefore the Flip-Flop has a permanent reset via OR10.

The Flip-Flop is set as soon as the Leader (CB1) indicates that Auto re-close is in progress. The Flip-Flop output then activates the ">Delay close cmd." in the follower. This is maintained until the leader can indicate that it has successfully re-closed. This indication is obtained via the "Remote close signal" from the leader which is routed to X1 of OR10.

To allow the "Follower" to re-close with a normal dead time when the "Leader" is open or out of service the "AR in progress" signal is used. As the initiation of the AR function in both circuit breakers is at the same time from the same source (the protection functions in FG Line), the AR in progress of the leader is a clear indication that the leader is in service and taking the its role as leader. If the leader is open for maintenance or the AR function is selected Off, the AR in progress from the leader will not assert, thereby allowing the "Follower" to re-close with a normal dead time.

When the Flip-flop is set, the output sets (via the Build SPS block) the signal Delay Close Command in the Follower. The AR function in the follower will go through all the normal states until the AR Close command is due. If the signal "Delay Close Command" is active the AR close will not be issued until this signal resets. If the maximum dead time extension (Setting Parameter) has expired before the release is given, the AR will be terminated with a definite trip.

SIPROTEC 5 Application

Breaker-and-a-half – Automatic reclosing and leader follower

General	
General	
302.1361.6601.1	Mode: on
302.1361.6601.101	79 operating mode: with op., with act. time
302.1361.6601.102	CB ready check bef. start: no
302.1361.6601.103	Reclai. time aft. succ. cyc.: 3.00 s
302.1361.6601.104	Block. time aft. man. close: 1.00 s
302.1361.6601.105	Start signal superv. time: 0.25 s
302.1361.6601.106	CB ready superv. time: 3.00 s
302.1361.6601.107	3-pole operate by 79: yes
302.1361.6601.108	Evolving-fault detection: with trip
302.1361.6601.109	Response to evol. faults: blocks 79
302.1361.6601.110	Max. dead-time delay: 0.50 s
302.1361.6601.111	Max. dead-time extension: 1.20 s
302.1361.6601.112	Send delay f. remot. close: 0.05 s

Figure 7: AR Function General Settings

The General settings for the AR function in both circuit breakers can be the same. The Leader must have a set time for "Send delay for remote close" as this determines how long after the Leader close command the follower is released. As the Leader/Follower selection can be set via marker command in this application, the AR settings for both circuit breakers is identical.

The "Max. dead time extension" must be set longer than the release delay from the leader as set above. In this case the follower is released 50ms after the successful re-close of the leader (Send delay for remote close).

Single Pole Trip / Operate

As the two circuit breakers execute their AR cycles independently, they can be individually set to trip and AR: 1-pol, 3-pol or 1- and 3-pol. Although any combination is theoretically possible, it is not recommended to have single pole re-close by the follower when the leader is doing only 3-pol AR cycles.

1.5 Conclusion

The leader/follower operation of the auto re-close function in a breaker-and-a-half application with SIPROTEC5 can be achieved with the standard auto re-close functions. The full scope of single and three pole AR with multiple stages is therefore available.

By means of a simple logic (included in the template for breaker-and-a-half) the leader follower logic is implemented. There is no need to change settings or setting groups when changing the Leader/Follower configuration – this is done with a single marker command that can be changed by the operator at any time.

Published by
Siemens AG 2016
Energy Management Division
Digital Grid
Automation Products
Humboldtstr. 59
90459 Nuremberg, Germany

www.siemens.com/siprotec

For more information,
please contact our
Customer Support Center.

Tel.: +49 180 524 70 00

Fax: +49 180 524 24 71

(Charges depending on provider)

Email: support.energy@siemens.com

© 2016 Siemens. Subject to changes and errors.
The information given in this document only contains
general descriptions and/or performance features which
may not always specifically reflect those described, or
which may undergo modification in the course of further
development of the products. The requested performance
features are binding only when they are expressly agreed
upon in the concluded contract.

For all products using security features of OpenSSL, the
following shall apply:
This product includes software developed by the OpenSSL
Project for use in the OpenSSL Toolkit.
(<http://www.openssl.org/>)
This product includes cryptographic software written by
Eric Young (eay@cryptsoft.com)
This product includes software written by Tim Hudson
(tjh@cryptsoft.com)
This product includes software developed by Bodo Moeller.