

Siemens Industry, Inc.
Norcross, Ga 30092 U.S.A.

For questions call 1-800-241-4453 or our web site:
<http://www.usa.siemens.com/powerdistribution>

For use with:
200 Amp VBII Safety Switches

Page 1 of 2

Pc. No. 500212C01

Installation Instructions for Replacement Line Base Kit



⚠ DANGER

Hazardous voltage.
Will cause death or serious injury.

Turn off and lock out all power supplying this Safety Switch before installing kit.

Close line shield and cover before restoring power to switch.

⚠ SAFETY INSTRUCTIONS

Note: This instruction outlines recommended installation procedure.

Note: All replacement Line Base Assemblies are 3-Pole. For 2-Pole switches use outer poles.

1. Turn OFF and lock out all power supplying the Safety Switch.
2. Turn the Safety Switch OFF.
3. Verify moveable contacts are in the OFF position. **(See Figure 1)**
4. Verify that NO voltage is present at the wire grips.
5. Remove fuses if installed.
6. Open line shield.
7. Remove all conductors from the line base.
8. Remove neutral if installed, see **Figure 2** for mounting and bonding screw locations.
9. Remove line base mounting screws. **(See Figure 2)**
10. Slide line base to the left to disengage the rotor from the switch mechanism and remove line base.

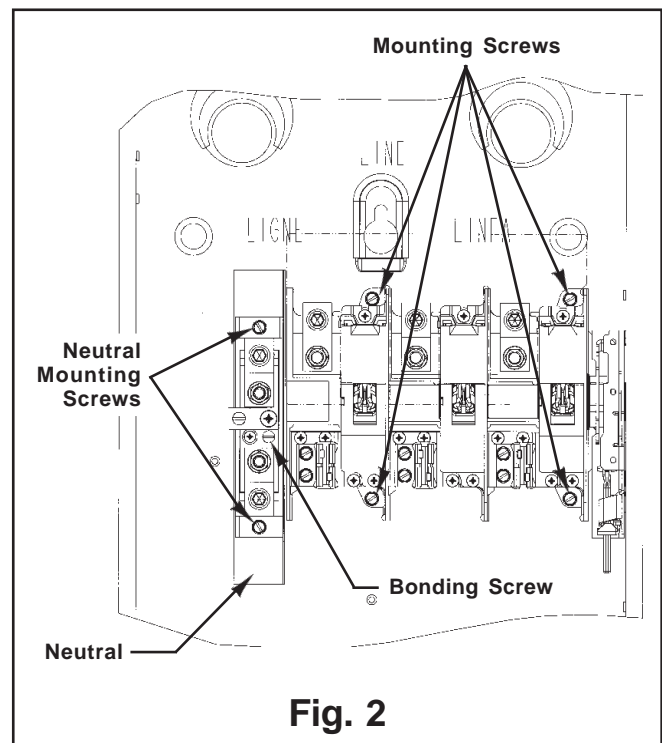
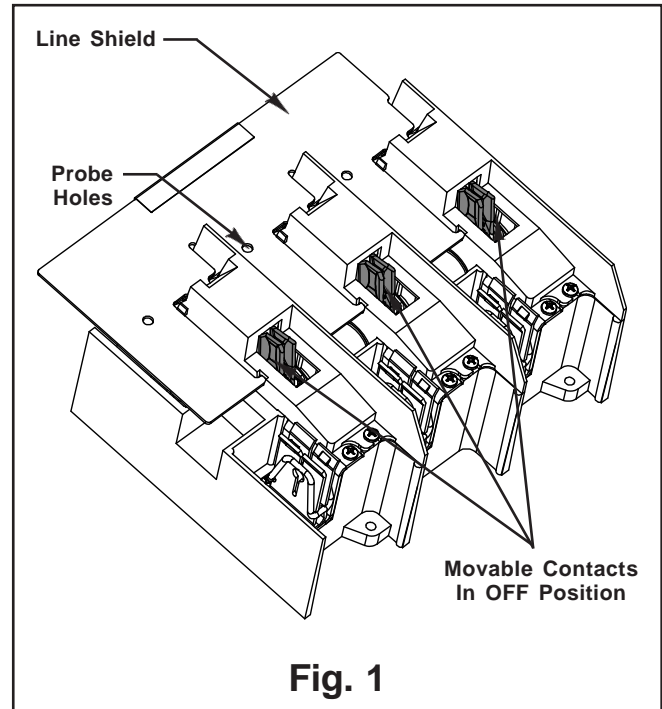



Installation Instructions for Replacement Line Base Kit

11. Install replacement line base. Making sure that the moveable contacts are visible (switch in OFF position), slide line base to the right, inserting line base rotor into mechanism cam. (See Figure 3). Install mounting screws and torque to 29 lb-ins. (See Figure 2)
12. Reinstall any accessory kits attached to the original line base assembly per the instructions included in this kit. These may include: Copper Wire Grip, Neutral, 200% Neutral, Compression Lug Neutral Barrier Kit and fuse puller accessories.
13. Reinstall line base conductors. Torque lugs to the wire tightening torque values listed in the Terminal & Wire Information Table on the interior label.
14. Install fuses if removed in step 5.
15. Close line shield.
16. **While power supplying switch is still OFF**, check switch operation. Cycle mechanism while checking for smooth switch operation and moveable contact movement. (Hold switch interlock lever below the front of the enclosure to operate switch with the door open on Heavy Duty Switches.) (See Figure 3) If switch does not operate in a smooth manner, or if there are any questions about replacement kit installation, contact Customer Service 1-800-241-4453.
17. Turn the Safety Switch OFF.
18. Close cover before supplying power to the safety switch.

