

# SIEMENS

## Outdoor Uni-PAK All-In-One Metering

Catalog Number

**WP5411, WP5411RJ, WP5411RJB**

Enclosure

**Type 3R**

Main Bus Rating: 500 Amps

120/240 V~, 1 Phase, 3 Wire

208Y/120 V~, 1 Phase, 3 Wire (5th jaw may be required)

Meter Socket Rating: 125A Continuous

Branch Rating: 125A Max.

For installation by Qualified Person in accordance with all local electrical codes and/or the National Electrical Code ®.

**Suitable Only For Use As Service Equipment.** Install no more than six main disconnecting means.

For overhead or underground service.

**Use 60/75°C Copper or Aluminum Conductors** for all panel terminals and on circuit breaker terminals when breakers are so marked.

Terminal	Wire Size	Torque
A, B, N1	(2) 600 kcmil-#2 AWG	375 LB-IN
G	300 kcmil - #4 AWG	275 LB-IN
N2/Equip GND	#2/0 - 4 AWG	110 LB-IN
Alt. Lug Kit WPLK2600	(3) 300 kcmil-#4 AWG	275 LB-IN

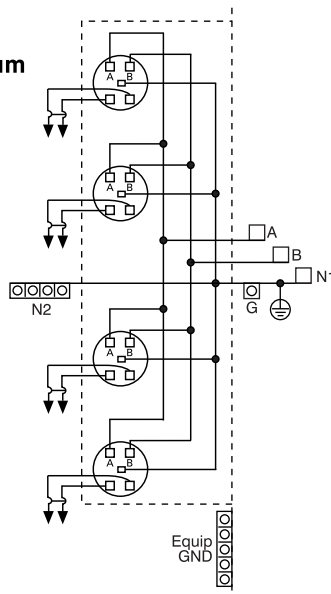

# SIEMENS

## Outdoor Uni-PAK All-In-One Metering

General Information:

Circuit breaker overload trip position is indicated by handle position midway between ON and OFF. To reset, move handle to OFF position, then turn ON.

### Short Circuit Current Rating

The maximum short circuit current rating of this device is 100,000 RMS symmetrical amperes, 120/240 V~. The actual rating is limited to the lowest interrupting rating of any circuit breaker installed. Use only Siemens type QP, QPH, HQP, HQPH, MP-T, MP-HT or MP-MT circuit breakers. Use of other circuit breakers in this device will void the warranty.

### Accessories

5th Jaw, 6 or 9 o'Clock Position. . . . . ECMF5  
Insulated 5th Jaw, 6 or 9 o'Clock Pos. . . . . ECMF5i  
Meter Socket Cover Plate (Ring Type) . . . . . ECPP  
Meter Socket Cover Plate (Ringless) . . . . . ECCP3  
Horn By-Pass (Ringless Only). . . . . ECMFH

### Use HD Type Hubs if required

Trade Size (in)	Catalog No.
2"	EC56854
2-1/2"	EC56855
3"	EC56856
3-1/2"	EC56857
4"	EC56858
Closure Plate	EC56933S

**Important:** Do not allow petroleum based (hydrocarbon) sprays, chemicals, solvents or any paint to contact interior components. Petroleum based chemicals can cause degradation of electrical insulating materials.