

Features and Ratings

- MAIN BUS RATING: 1200 AMPS, 240V AC MAX.
- MODULE RATING: 800 AMPS MAX, 240V AC MAX.
- 100,000 AIC RATING MAX.
- 3 PHASE
- TYPE 3R OUTDOOR ENCLOSURE
- FOR OVERHEAD OR UNDERGROUND SERVICE
- MOUNTING RAILS AND ADJUSTABLE BRACKETS FOR SECURE MOUNTING

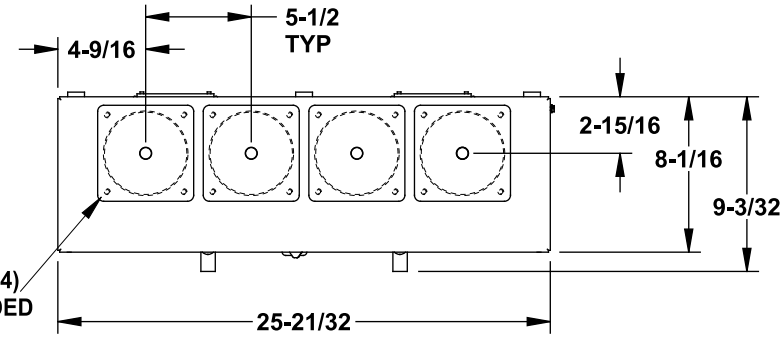

VIEW SHOWN WITHOUT COVERS

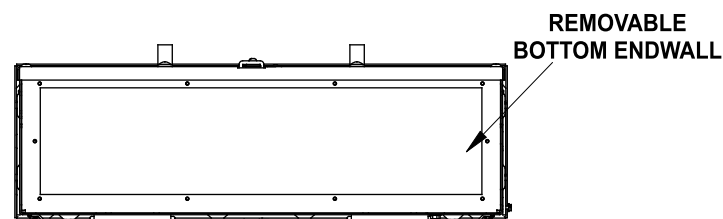
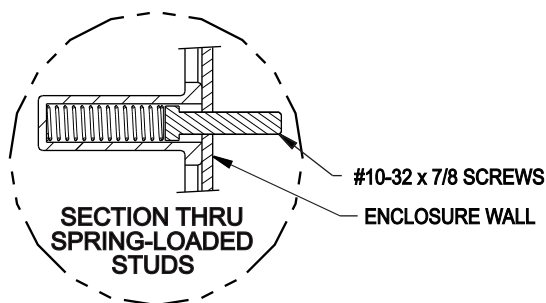
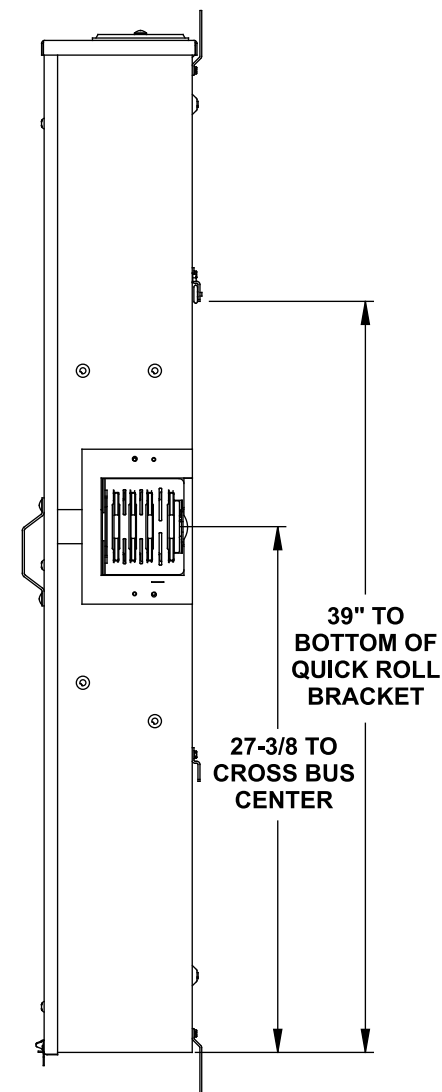
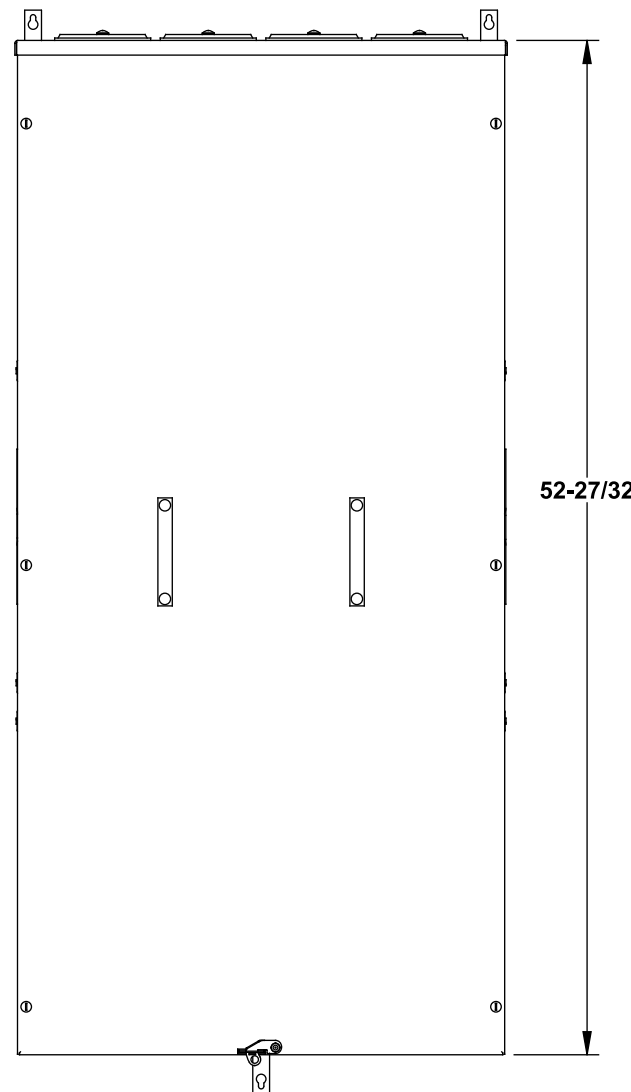
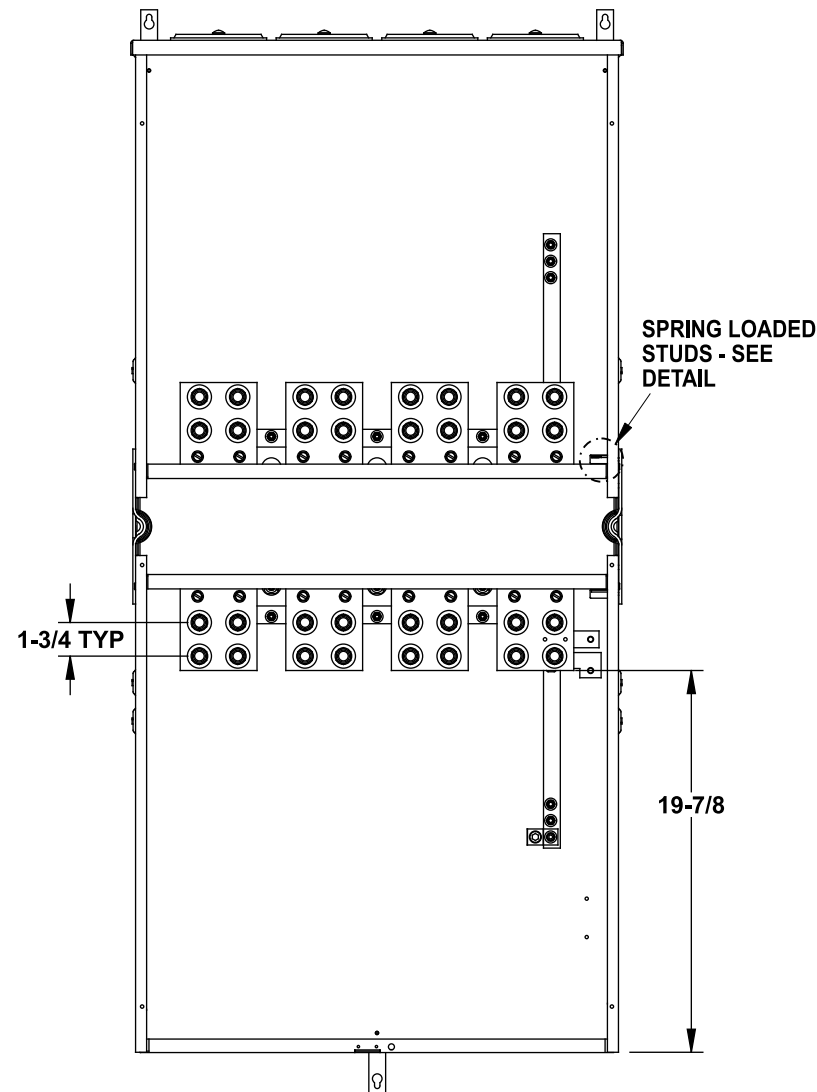

Lug Kits and Replacement Parts

Lugs for Phase and Neutral Connections (not supplied)					
Lug No.	MFG	Wire Range	Type	No. Wires per phase	Torque (lb.-in.)
LK32600N2	Siemens	#2-600 kcmil	Mechanical	2	375
LK32750N2	Siemens	300-750 kcmil	Mechanical	2	500
LK33500N2	Siemens	1/0-500 kcmil	Mechanical	1	375 ②
				2	500 ②
2ACL-500	ILSCO	500 kcmil	Compression	3	NA ③
2ACL-600	ILSCO	600 kcmil	Compression	2	NA ③
2ACL-750	ILSCO	750 kcmil	Compression	2	NA ③

- ① Order one mechanical lug kit for mains and neutral. Contact lug manufacturer for compression lug quantities supplied for each kit.
 ② Kit contains more than one lug type. Reference kit instruction sheet for the actual torque value for each lug type.
 ③ See lug manufacturer's instruction sheet supplied with the connector for tool, die, and number of crimps.

Additional Modules

FOR USE WITH: Module Description	Siemens Series#
Main Breakers	WB, WEB, WXB
Switches	WS, WES
Tap/Terminal Boxes	WTB, WET, WT, PU
Meter Module	(W)MM, (W)ML
Meter Combinations	WC, WCL
Extension Box	WSP, WSPD
Bussed Elbow	BE

Connect Modules Using:	Catalog Number / Torque
QuickConnect	QC4, Torque 400-440 lb-in (35-36 ft.-lb.)

Accessories

Description	Catalog No.
Ground Bar Kit	ECLX069M
Parts Kit	ECMFPK
Mounting Rail	MMRAIL
Mounting Clip	MMCLIP
Mounting Tabs (2)	ECMFTAB
Back Rail/Clip	ECMFWLCLIP
Wall Mounting Rail (60")	MMZR60

Siemens Accessories	Catalog Number
Hub Cover Plate	EC56933S
Type HD Hub 2"	EC56854
Type HD Hub 2-1/2"	EC56855
Type HD Hub 3"	EC56856
Type HD Hub 3-1/2"	EC56857
Type HD Hub 4"	EC56858

Schematic

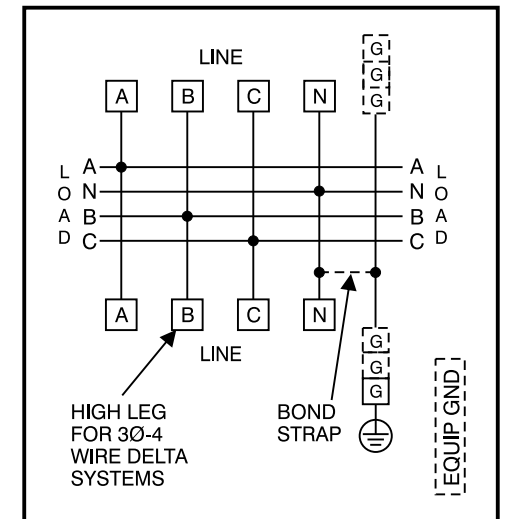

Catalog No. **WTBN3800CU**

© 2013 Copyright Siemens Industry, Inc.

SIEMENS
Siemens Industry, Inc.

PowerMod™ Tap Box

Catalog Numbers: **3 Phase, 800 Amp Service Entrance Tap Box (CE)**

Size B Dwg. No. **WTBN3800CU**