

SIEMENS

SIPROTEC

**Overcurrent Time Protection
7SJ80 CEI 0-16 Standard**

V4.7

Manual

Preface

Contents

Introduction

1

Functions

2

Mounting and Commissioning

3

Technical Data

4

Appendix

A

Literature

Glossary

Index

**Note**

For safety purposes, please note instructions and warnings in the Preface.

Disclaimer of Liability

We have checked the contents of this manual against the hardware and software described. However, deviations from the description cannot be completely ruled out, so that no liability can be accepted for any errors or omissions contained in the information given.

The information given in this document is reviewed regularly and any necessary corrections will be included in subsequent editions. We appreciate any suggested improvements.

We reserve the right to make technical improvements without notice.

Document version V 04.00.01

Release date 11.2013

Copyright

Copyright © Siemens AG 2012. All rights reserved.

Dissemination or reproduction of this document, or evaluation and communication of its contents, is not authorized except where expressly permitted. Violations are liable for damages. All rights reserved, particularly for the purposes of patent application or trademark registration.

Registered Trademarks

SIPROTEC, SINAUT, SICAM and DIGSI are registered trademarks of Siemens AG. Other designations in this manual might be trademarks whose use by third parties for their own purposes would infringe the rights of the owner.

Preface

Purpose of this Manual

This manual describes the functions, operation, installation, and commissioning of 7SJ80 devices. In particular, one will find:

- Information regarding the configuration of the scope of the device and a description of the device functions and settings → Chapter 2;
- Instructions for Installation and Commissioning → Chapter 3;
- Compilation of the Technical Data → Chapter 4;
- As well as a compilation of the most significant data for advanced users → Appendix A.

General information with regard to design, configuration, and operation of SIPROTEC 4 devices are set out in the SIPROTEC 4 System Description /1/.

Target Audience

Protection engineers, commissioning engineers, personnel concerned with adjustment, checking, and service of selective protective equipment, automatic and control facilities, and personnel of electrical facilities and power plants.

Applicability of this Manual

This manual is valid for: SIPROTEC 4 Multifunctional Protection Device 7SJ80; Firmware Version V4.7

Indication of Conformity

	<p>This product complies with the directive of the Council of the European Communities on the approximation of the laws of the Member States relating to electromagnetic compatibility (EMC Council Directive 2004/108/EC) and concerning electrical equipment for use within specified voltage limits (Low-voltage Directive 2006/95 EC).</p> <p>This conformity is proved by tests conducted by Siemens AG in accordance with the Council Directive in agreement with the generic standards EN 61000-6-2 and EN 61000-6-4 for EMC directive, and with the standard EN 60255-27 for the low-voltage directive.</p> <p>The device has been designed and produced for industrial use.</p> <p>The product conforms with the international standards of the series IEC 60255 and the German standard VDE 0435.</p>
---	---

Additional Standards IEEE C37.90 (see Chapter 4 "Technical Data")
This product is UL-certified according to the Technical Data.
file E194016



IND. CONT. EQ.
69CA

Additional Support

Should further information on the System SIPROTEC 4 be desired or should particular problems arise which are not covered sufficiently for the purchaser's purpose, the matter should be referred to the local Siemens representative.

Our Customer Support Center provides a 24-hour service.

Phone: +49 (180) 524-8437

Fax: +49 (180) 524-2471

e-mail: support.ic@siemens.com

Training Courses

Enquiries regarding individual training courses should be addressed to our Training Center:

Siemens AG

Siemens Power Academy

Humboldt Street 59

90459 Nuremberg

Telephone: +49 (911) 433-7415

Fax: +49 (911) 433-5482

Internet: www.siemens.com/energy/power-academy

e-mail: td.power-academy.energy@siemens.com

Safety Information

This manual does not constitute a complete index of all required safety measures for operation of the equipment (module, device), as special operational conditions may require additional measures. However, it comprises important information that should be noted for purposes of personal safety as well as avoiding material damage. Information that is highlighted by means of a warning triangle and according to the degree of danger, is illustrated as follows.



DANGER!

Danger indicates that death, severe personal injury or substantial material damage will result if proper precautions are not taken.

**WARNING!**

indicates that death, severe personal injury or substantial property damage may result if proper precautions are not taken.

**Caution!**

indicates that minor personal injury or property damage may result if proper precautions are not taken. This particularly applies to damage to or within the device itself and consequential damage thereof.

**Note**

indicates information on the device, handling of the device, or the respective part of the instruction manual which is important to be noted.

**WARNING!****Qualified Personnel**

Commissioning and operation of the equipment (module, device) as set out in this manual may only be carried out by qualified personnel. Qualified personnel in terms of the technical safety information as set out in this manual are persons who are authorized to commission, activate, to ground and to designate devices, systems and electrical circuits in accordance with the safety standards.

Use as prescribed

The operational equipment (device, module) may only be used for such applications as set out in the catalog and the technical description, and only in combination with third-party equipment recommended or approved by Siemens.

The successful and safe operation of the device is dependent on proper handling, storage, installation, operation, and maintenance.

When operating an electrical equipment, certain parts of the device are inevitably subject to dangerous voltage. Severe personal injury or property damage may result if the device is not handled properly.

Before any connections are made, the device must be grounded to the ground terminal.

All circuit components connected to the voltage supply may be subject to dangerous voltage.

Dangerous voltage may be present in the device even after the power supply voltage has been removed (capacitors can still be charged).

Operational equipment with exposed current transformer circuits may not be operated.

The limit values as specified in this manual or in the operating instructions may not be exceeded. This aspect must also be observed during testing and commissioning.

Typographic and Symbol Conventions

The following text formats are used when literal information from the device or to the device appear in the text flow:

Parameter Names

Designators of configuration or function parameters which may appear word-for-word in the display of the device or on the screen of a personal computer (with operation software DIGSI), are marked in bold letters in monospace type style. The same goes for the titles of menus.

1234A

Parameter addresses have the same character style as parameter names. Parameter addresses contain the suffix **A** in the overview tables if the parameter can only be set in DIGSI via the option **Display additional settings**.

Parameter Options







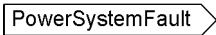

Possible settings of text parameters, which may appear word-for-word in the display of the device or on the screen of a personal computer (with operation software DIGSI), are additionally written in italics. This also applies to header bars for selection menus.

„Messages“

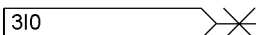
Designators for information, which may be output by the relay or required from other devices or from the switch gear, are marked in a monospace type style in quotation marks.

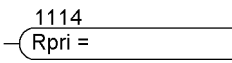
Deviations may be permitted in drawings and tables when the type of designator can be obviously derived from the illustration.

The following symbols are used in drawings:

	Device-internal logical input signal
	Device-internal logical output signal
	Internal input signal of an analog quantity
	External binary input signal with number (binary input, input indication)
	External binary input signal with number (example of a value indication)
	External binary output signal with number (device indication) used as input signal
 	Example of a parameter switch designated FUNCTION with address 1234 and the possible settings ON and OFF

Besides these, graphical symbols are used according to IEC 60617-12 and IEC 60617-13 or symbols derived from these standards. Some of the most frequently used are listed below:

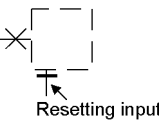
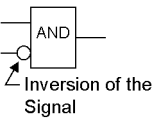
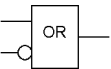
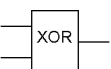
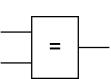
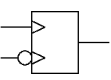
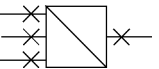
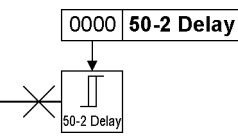
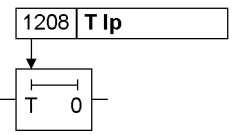
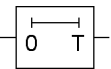
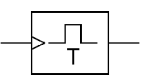
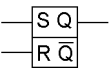
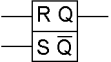
	<p>Analog input variable</p>
	<p>AND operation of input variables</p>
	<p>OR operation of input variables</p>
	<p>Exclusive OR (antivalence): output is active if only one of the inputs is active</p>
	<p>Coincidence: output is active if both inputs are active or inactive at the same time</p>
	<p>Dynamic input signals (edge-triggered) above with positive, below with negative edge</p>
	<p>Formation of one analog output signal from a number of analog input signals</p>
	<p>Threshold element with setting address and parameter names</p>
	<p>Timer (pickup delay T adjustable) with setting address and parameter names</p>
	<p>Timer (dropout delay T not adjustable)</p>
	<p>Edge-triggered time element with action time T</p>
	<p>Static memory (SR flipflop) with setting input (S), resetting input (R), output (Q) and inverted output (\bar{Q}), setting input dominant</p>
	<p>Static memory (RS-flipflop) with resetting input (R) setting input (S), output (Q) and inverted output (\bar{Q}), resetting input dominant</p>



Contents

- 1 Introduction.....19**
 - 1.1 Overall Operation.....20
 - 1.2 Application Scope.....23
 - 1.3 Characteristics.....25

- 2 Functions.....31**
 - 2.1 General.....32
 - 2.1.1 Functional Scope.....32
 - 2.1.1.1 Description.....32
 - 2.1.1.2 Setting Notes.....32
 - 2.1.1.3 Settings.....34
 - 2.1.2 Device, General Settings.....36
 - 2.1.2.1 Description.....36
 - 2.1.2.2 Setting Notes.....37
 - 2.1.2.3 Settings.....38
 - 2.1.2.4 Information List.....39
 - 2.1.3 Power System Data 1.....40
 - 2.1.3.1 Description.....40
 - 2.1.3.2 Setting Notes.....41
 - 2.1.3.3 Settings.....52
 - 2.1.3.4 Information List.....55
 - 2.1.4 Oscillographic Fault Records.....55
 - 2.1.4.1 Description.....56
 - 2.1.4.2 Setting Notes.....57
 - 2.1.4.3 Settings.....57
 - 2.1.4.4 Information List.....58
 - 2.1.5 Settings Groups.....58
 - 2.1.5.1 Description.....58
 - 2.1.5.2 Setting Notes.....58
 - 2.1.5.3 Settings.....58
 - 2.1.5.4 Information List.....59
 - 2.1.6 Power System Data 2.....60
 - 2.1.6.1 Description.....60
 - 2.1.6.2 Setting Notes.....60
 - 2.1.6.2 Setting Notes.....60
 - 2.1.6.3 Special Feature In CEI 0-16 Standard.....65
 - 2.1.6.5 Information List.....66
 - 2.1.7 EN100-Module.....67
 - 2.1.7.1 Description.....67
 - 2.1.7.2 Setting Notes.....67
 - 2.1.7.3 Information List.....67

2.2	Overcurrent Protection 50, 51, 50N, 51N	68
2.2.1	General	68
2.2.2	Definite Time High-set Elements 50-3, 50-2, 50N-3, 50N-2	69
2.2.3	Definite Time Overcurrent Elements 50-1, 50N-1	72
2.2.4	Inverse Time Overcurrent Elements 51, 51N	75
2.2.5	Inverse Time Overcurrent Protection 51V (Voltage-controlled / Voltage-restraint)	78
2.2.6	Dynamic Cold Load Pickup Function	80
2.2.7	Inrush Restraint	81
2.2.8	Pickup Logic and Tripping Logic	83
2.2.9	Two-phase Time Overcurrent Protection (only non-directional)	84
2.2.10	Fast Busbar Protection Using Reverse Interlocking	84
2.2.11	Setting Notes	85
2.2.12	Settings	91
2.2.13	Information List	93
2.3	Directional Overcurrent Protection 67, 67N	96
2.3.1	General	96
2.3.2	Definite Time, Directional High-set Elements 67-2, 67N-2	98
2.3.3	Directional Definite Time Overcurrent Elements 67-1, 67N-1	100
2.3.4	Inverse Time, Directional Overcurrent Elements 67-TOC, 67N-TOC	102
2.3.5	Interaction with the Fuse Failure Monitor (FFM)	104
2.3.6	Dynamic Cold Load Pickup	104
2.3.7	Inrush Restraint	104
2.3.8	Determination of Direction	104
2.3.9	Reverse Interlocking for Double End Fed Lines	109
2.3.10	Setting Notes	110
2.3.11	Settings	117
2.3.12	Information List	120
2.4	Dynamic Cold Load Pickup	122
2.4.1	Description	122
2.4.2	Setting Notes	124
2.4.3	Settings	126
2.4.4	Information List	127
2.5	Single-Phase Overcurrent Protection	128
2.5.1	Functional Description	128
2.5.2	High-impedance Ground Fault Unit Protection	129
2.5.3	Tank Leakage Protection	131
2.5.4	Setting Notes	132
2.5.5	Settings	137
2.5.6	Information List	137

2.6	Voltage Protection 27, 59	138
2.6.1	Voltage protection (Global standard)	138
2.6.1.1	Measurement Principle	138
2.6.1.2	Overvoltage Protection 59	140
2.6.1.3	Undervoltage Protection 27	141
2.6.1.4	Setting Notes	143
2.6.1.5	Settings	146
2.6.1.6	Information List	147
2.6.2	Voltage protection (CEI 0-16standard)	148
2.6.2.1	Measurement Principle	148
2.6.2.2	Overvoltage Protection 59	151
2.6.2.3	Undervoltage Protection 27	152
2.6.2.4	Setting Notes	156
2.6.2.5	Settings	158
2.6.2.6	Information List	158
2.7	Negative Sequence Protection 46	160
2.7.1	Definite Time Characteristic	160
2.7.2	Inverse Time Characteristic 46-TOC	161
2.7.3	Setting Notes	163
2.7.4	Settings	165
2.7.5	Information List	166
2.8	Frequency Protection 81 O/U	167
2.8.1	Frequency Protection 81 O/U (Global Standard)	167
2.8.1.1	Description	167
2.8.1.2	Setting Notes	169
2.8.1.3	Settings	170
2.8.1.4	Information List	171
2.8.2	Frequency Protection 81 O/U (CEI 0-16 Standard)	172
2.8.2.1	Description	172
2.8.2.2	Setting Notes	176
2.8.2.3	Settings	178
2.8.2.4	Information List	179
2.9	Undervoltage-controlled reactive power protection (27/Q)	180
2.9.1	Description	180
2.9.2	Setting Notes	182
2.9.3	Settings	184
2.9.4	Information List	184
2.10	Thermal Overload Protection 49	185
2.10.1	Description	185
2.10.2	Setting Notes	188
2.10.3	Settings	190
2.10.4	Information List	190

2.11	Monitoring Functions	191
2.11.1	Measurement Supervision	191
2.11.1.1	General	191
2.11.1.2	Hardware Monitoring	191
2.11.1.3	Software Monitoring	193
2.11.1.4	Monitoring of the Transformer Circuits	194
2.11.1.5	Measuring Voltage Failure Detection	196
2.11.1.6	Broken Wire Monitoring of Voltage Transformer Circuits	199
2.11.1.7	Setting Notes	201
2.11.1.8	Settings	202
2.11.1.9	Information List	203
2.11.2	Trip Circuit Supervision 74TC	204
2.11.2.1	Description	204
2.11.2.2	Setting Notes	207
2.11.2.3	Settings	208
2.11.2.4	Information List	208
2.11.3	Malfunction Responses of the Monitoring Functions	208
2.11.3.1	Description	208
2.12	Ground Fault Protection 64, 67N(s), 50N(s), 51N(s)	211
2.12.1	Ground Fault Detection for $\cos\varphi$ - / $\sin\varphi$ Measurement (Standard Method)	211
2.12.2	Ground Fault Detection for V_0/I_0 - φ Measurement	218
2.12.3	Ground Fault Location	222
2.12.4	Setting Notes	223
2.12.5	Settings	230
2.12.6	Information List	232
2.13	Intermittent Ground Fault Protection	233
2.13.1	Description	233
2.13.2	Setting Notes	237
2.13.3	Settings	238
2.13.4	Information List	239
2.14	Dir. Intermittent earth fault protection	240
2.14.1	Description	240
2.14.2	Setting Notes	243
2.14.3	Settings	244
2.14.4	Information List	244
2.15	Automatic Reclosing System 79	245
2.15.1	Program Execution	245
2.15.2	Blocking	250
2.15.3	Status Recognition and Monitoring of the Circuit Breaker	251
2.15.4	Controlling Protection Elements	253
2.15.5	Zone Sequencing / Fuse Saving Scheme	254
2.15.6	Setting Notes	255
2.15.7	Settings	261
2.15.8	Information List	267

2.16	Fault Locator269
2.16.1	Description269
2.16.2	Setting Notes270
2.16.3	Settings271
2.16.4	Information List.271
2.17	Breaker Failure Protection 50BF272
2.17.1	Description272
2.17.2	Setting Notes276
2.17.3	Settings277
2.17.4	Information List.277
2.18	Flexible Protection Functions.278
2.18.1	Description278
2.18.2	Setting Notes283
2.18.3	Settings288
2.18.4	Information List.290
2.19	Reverse-Power Protection Application with Flexible Protection Function291
2.19.1	Description291
2.19.2	Implementation of the Reverse Power Protection294
2.19.3	Configuring the Reverse Power Protection in DIGSI296
2.20	Synchrocheck299
2.20.1	General299
2.20.2	Functional Sequence301
2.20.3	De-energized Switching302
2.20.4	Direct Command / Blocking303
2.20.5	Interaction with Control, Automatic Reclosing and External Control304
2.20.6	Setting Notes306
2.20.7	Settings310
2.20.8	Information List.311
2.21	Phase Rotation313
2.21.1	Description313
2.21.2	Setting Notes314
2.22	Function Logic315
2.22.1	Pickup Logic of the Entire Device315
2.22.2	Tripping Logic of the Entire Device316
2.22.3	Setting Notes316

2.23	Auxiliary Functions	317
2.23.1	Message Processing	317
2.23.1.1	LEDs and Binary Outputs (Output Relays)	317
2.23.1.2	Information via Display Field or PC	318
2.23.1.3	Information to a Control Center	319
2.23.2	Statistics	319
2.23.2.1	Description	320
2.23.2.2	Circuit Breaker Maintenance	320
2.23.2.3	Setting Notes	326
2.23.2.4	Information List	328
2.23.3	Measurement	329
2.23.3.1	Display of Measured Values	329
2.23.3.2	Transmitting Measured Values	331
2.23.3.3	Information List	331
2.23.4	Average Measurements	332
2.23.4.1	Description	332
2.23.4.2	Setting Notes	333
2.23.4.3	Settings	333
2.23.4.4	Information List	333
2.23.5	Min/Max Measurement Setup	334
2.23.5.1	Description	334
2.23.5.2	Setting Notes	334
2.23.5.3	Settings	334
2.23.5.4	Information List	334
2.23.6	Set Points for Measured Values	336
2.23.6.1	Setting Notes	336
2.23.7	Set Points for Statistic	337
2.23.7.1	Description	337
2.23.7.2	Setting Notes	337
2.23.7.3	Information List	337
2.23.8	Energy Metering	338
2.23.8.1	Description	338
2.23.8.2	Setting Notes	338
2.23.8.3	Settings	338
2.23.8.4	Information List	338
2.23.9	Commissioning Aids	339
2.23.9.1	Description	339
2.24	Breaker Control	341
2.24.1	Control Device	341
2.24.1.1	Description	341
2.24.1.2	Information List	342
2.24.2	Command Types	343
2.24.2.1	Description	343
2.24.3	Command Sequence	344
2.24.3.1	Description	344
2.24.4	Interlocking	345
2.24.4.1	Description	345
2.24.5	Command Logging	352
2.24.5.1	Description	352
2.25	Notes on Device Operation	353
2.25.1	Different operation	353

3	Mounting and Commissioning	.355
3.1	Mounting and Connections	.356
3.1.1	Configuration Information	.356
3.1.2	Hardware Modifications	.360
3.1.2.1	Disassembly	.360
3.1.2.2	Connections of the Current Terminals	.363
3.1.2.3	Connections of the Voltage Terminals	.364
3.1.2.4	Interface Modules	.365
3.1.2.5	Reassembly	.367
3.1.3	Installation	.369
3.1.3.1	General	.369
3.1.3.2	Panel Flush Mounting	.370
3.1.3.3	Cubicle Mounting	.371
3.1.3.4	Panel Surface Mounting	.372
3.2	Checking Connections	.373
3.2.1	Checking the Data Connections of the Interfaces	.373
3.2.2	Checking the System Connections	.376
3.3	Commissioning	.378
3.3.1	Test Mode and Transmission Block	.379
3.3.2	Testing the System Interface (at Port B)	.379
3.3.3	Configuring Communication Modules	.381
3.3.4	Checking the Status of Binary Inputs and Outputs	.384
3.3.5	Tests for Breaker Failure Protection	.387
3.3.6	Testing User-Defined Functions	.388
3.3.7	Current, Voltage, and Phase Rotation Testing	.388
3.3.8	Test for High Impedance Protection	.390
3.3.9	Testing the Reverse Interlocking Scheme	.390
3.3.10	Direction Check with Load Current	.391
3.3.11	Polarity Check for Voltage Input V_3	.392
3.3.12	Ground Fault Check	.394
3.3.13	Polarity Check for Current Input I_N	.395
3.3.14	Trip/Close Tests for the Configured Operating Devices	.397
3.3.15	Creating Oscillographic Recordings for Tests	.397
3.4	Final Preparation of the Device	.399
4	Technical Data	.401
4.1	General Device Data	.402
4.1.1	Analog Inputs	.402
4.1.2	Auxiliary voltage	.403
4.1.3	Binary Inputs and Outputs	.403
4.1.4	Communication Interfaces	.404
4.1.5	Electrical Tests	.407
4.1.6	Mechanical Tests	.408
4.1.7	Climatic Stress Tests	.409
4.1.8	Service Conditions	.409
4.1.9	Constructive Design	.410
4.1.10	UL certification conditions	.410

4.2	Definite-time Overcurrent Protection	411
4.3	Inverse-time Overcurrent Protection	413
4.4	Directional Overcurrent Protection	424
4.5	Inrush Restraint	426
4.6	Dynamic Cold Load Pickup	427
4.7	1-phase Overcurrent Protection	428
4.8	Voltage Protection	429
4.8.1	Voltage Protection (Global standard)	429
4.8.2	Voltage Protection (CEI 0-16 standard)	431
4.9	Negative Sequence Protection (definite-time characteristic)	432
4.10	Negative Sequence Protection (inverse-time characteristics)	433
4.11	Frequency Protection	439
4.11.1	Frequency Protection 81 O/U (Global Standard)	439
4.11.2	Frequency Protection 81 O/U (CEI 0-16 Standard)	440
4.12	Undervoltage-controlled reactive power protection (27/Q)	442
4.13	Thermal Overload Protection	444
4.14	Ground Fault Detection (Sensitive/Insensitive)	446
4.15	Intermittent Ground Fault Protection	450
4.16	Directional intermittent ground fault protection	451
4.17	Automatic Reclosing System 79	452
4.18	Fault Locator	453
4.19	Breaker Failure Protection 50BF	454
4.20	Flexible Protection Functions	455
4.21	Synchrocheck 25	458
4.22	User-defined Functions (CFC)	460
4.23	Additional Functions	465
4.24	Switching Device Control	470
4.25	Dimensions	471
4.25.1	Panel Flush and Cubicle Mounting (Housing Size 1/6)	471
4.25.2	Panel Surface Mounting (Housing Size 1/6)	472
4.25.3	Bottom view	472
4.25.4	Varistor	473
A	Appendix	475
A.1	Ordering Information and Accessories	476
A.1.1	Ordering Information	476
A.1.1.1	7SJ80 V4.7	476
A.1.2	Accessories	480
A.2	Terminal Assignments	482
A.2.1	7SJ80 — Housing for panel flush mounting and cubicle installation and for panel surface mounting 482	
A.3	Connection Examples	488
A.3.1	Connection Examples for SICAM I/O Units	501

A.4	Current Transformer Requirements502
A.4.1	Accuracy limiting factors502
	Effective and Rated Accuracy Limiting Factor502
	Calculation example according to IEC 60044–1502
A.4.2	Class conversion503
A.4.3	Cable core balance current transformer.503
	General.503
	Requirements.503
	Class accuracy.504
A.5	Default Settings505
A.5.1	LEDs505
A.5.2	Binary Input506
A.5.3	Binary Output507
A.5.4	Function Keys507
A.5.5	Default Display508
A.6	Protocol-dependent Functions.511
A.7	Functional Scope512
A.7.1	Functional Scope (Global Standard)512
A.7.2	Functional Scope (CEI 0-16 Standard)513
A.8	Settings516
A.9	Information List537
A.10	Group Alarms.560
A.11	Measured Values563
	Literature565
	Glossary567
	Index579

Introduction

This chapter introduces the SIPROTEC 4 7SJ80 and gives an overview of the device's application, properties and functions.

1.1	Overall Operation	20
1.2	Application Scope	23
1.3	Characteristics	25

1.1 Overall Operation

The digital SIPROTEC 7SJ80 overcurrent protection is equipped with a powerful microprocessor. It allows all tasks to be processed digitally, from the acquisition of measured quantities to sending commands to circuit breakers. Figure 1-1 shows the basic structure of the 7SJ80.

Analog Inputs

The measuring inputs (MI) convert the currents and voltages coming from the measuring transformers and adapt them to the level appropriate for the internal processing of the device. The device provides 4 current transformers and - depending on the model - additionally 3 voltage transformers. Three current inputs serve for the input of the phase currents, another current input (I_N) may be used for measuring the ground fault current I_N (current transformer neutral point) or for a separate ground current transformer (for sensitive ground fault detection I_{Ns} and directional determination of ground faults) - depending on the model.

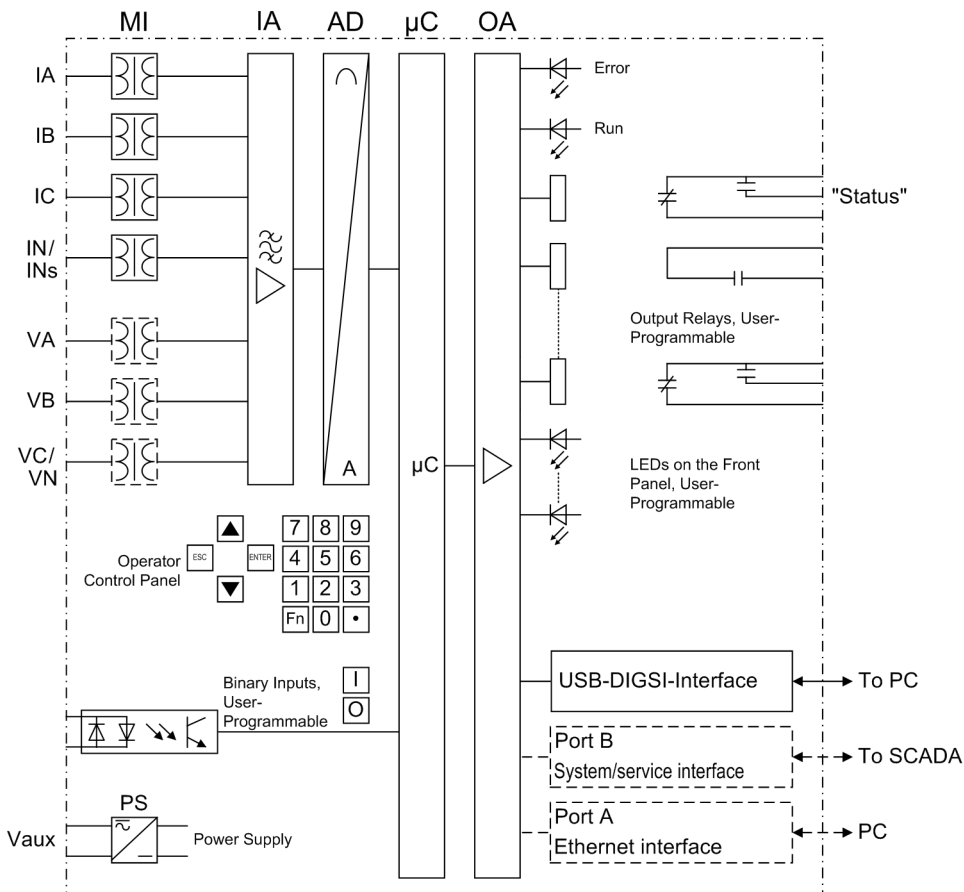

Figure 1-1 Hardware structure of the digital multi-functional protective relay 7SJ80

The optional voltage transformers can either be used to input 3 phase-to-Ground voltages or 2 phase-to-phase voltages and the displacement voltage (open delta voltage) or any other voltages. It is also possible to connect two phase-to-phase voltages in open delta connection.

The analog input quantities are passed on to the input amplifiers (IA). The input amplifier IA element provides a high-resistance termination for the input quantities. It consists of filters that are optimized for measured-value processing with regard to bandwidth and processing speed.

The analog-to-digital (AD) transformer group consists of an analog-to-digital converter and memory components for the transmission of data to the microcomputer.

Microcomputer System

Apart from processing the measured values, the microcomputer system (μ C) also executes the actual protection and control functions. They especially include:

- Filtering and preparation of the measured quantities
- Continuous monitoring of the measured quantities
- Monitoring of the pickup conditions for the individual protective functions
- Interrogation of limit values and sequences in time
- Control of signals for the logic functions
- Output of control commands for switching devices
- Recording of messages, fault data and fault values for analysis
- Management of the operating system and the associated functions such as data recording, real-time clock, communication, interfaces, etc.
- The information is distributed via output amplifiers (OA).

Binary Inputs and Outputs

The computer system obtains external information through the binary input/output boards (inputs and outputs). The computer system obtains information from the system (e.g. remote resetting) or from external equipment (e.g. blocking commands). These outputs include, in particular, trip commands to circuit breakers and signals for the remote indication of important events and conditions.

Front Panel

Information such as messages related to events, states, measured values and the functional status of the device are visualized by light-emitting diodes (LEDs) and a display screen (LCD) on the front panel.

Integrated control and numeric keys in conjunction with the LCD enable interaction with the remote device. These elements can be used to access the device for information such as configuration and setting parameters. Similarly, setting parameters can be accessed and changed if needed.

In addition, control of circuit breakers and other equipment is possible from the front panel of the device.

Interfaces

Communication with a PC can be implemented via the **USB DIGSI interface** using the DIGSI software, allowing all device functions to be easily executed.

Communication with a PC is also possible via **port A** (Ethernet interface) and **port B** (System/Service interface) using DIGSI.

In addition to the device communication via DIGSI, **port B** can also be used to transmit all device data to a central evaluator or a control center. This interface may be provided with various protocols and physical transmission schemes to suit the particular application.

Power Supply

A power supply unit (Vaux or PS) delivers power to the functional units using the different voltage levels. Voltage dips may occur if the voltage supply system (substation battery) becomes short-circuited. Usually, they are bridged by a capacitor (see also Technical Data).

A buffer battery is located under the flap at the lower end of the front cover.

1.2 Application Scope

The multi-function numerical overcurrent protection SIPROTEC 4 7SJ80 is used as protection, control and monitoring unit for busbar feeders. For line protection, the device can be used in networks with grounded, low-resistance grounded, isolated or a compensated neutral point structure. It is suited for networks that are radial and supplied from a single source, open or closed looped networks and for lines with sources at both ends.

The device includes the functions that are usually necessary for protection, monitoring of circuit breaker positions and control of circuit breakers in single and double busbars; therefore, the device can be employed universally. The device provides excellent backup protection of differential protective schemes of any kind for lines, transformers and busbars of all voltage levels.

Protective Functions

Non-directional overcurrent protection (50, 50N, 51, 51N) is the basic function of the device. There are three definite time elements and one inverse time Element for the phase currents and the ground current. For the inverse time Elements, several characteristics of different standards are provided. Alternatively, a user-defined Curve can be used for the sensitive ground fault detection.

Further protection functions included are the negative sequence protection, overload protection, circuit breaker failure protection and ground fault protection.

Depending on the ordered variant, further protection functions are included, such as frequency protection, overvoltage and undervoltage protection, and ground fault protection for high-resistance ground faults (directional or non-directional).

Apart from the short circuit protection functions mentioned before, there are further protection functions possible as order variants. The overcurrent protection can, for example, be supplemented by a directional overcurrent protection.

The automatic reclosing function enables several different reclosing cycles for overhead lines. An external automatic reclosing system can also be connected. To ensure quick detection of the fault location after a short circuit, the device is equipped with a fault locator.

Before reclosing after a three-pole tripping, the device can verify the validity of the reclosure via a voltage check and/or a synchrocheck. The synchrocheck function can also be controlled externally.

Control Functions

The device provides a control function which can be accomplished for activating and deactivating the switchgear via operator buttons, port B, binary inputs and - using a PC and the DIGSI software - via the front interface.

The status of the primary equipment can be transmitted to the device via auxiliary contacts connected to binary inputs. The present status (or position) of the primary equipment can be displayed on the device, and used for interlocking or alarm condition monitoring. The number of operating equipments to be switched is limited by the binary inputs and outputs available in the device or the binary inputs and outputs allocated for the switch position indications. Depending on the primary equipment being controlled, one binary input (single point indication) or two binary inputs (double point indication) may be used for this process.

The capability of switching primary equipment can be restricted by a setting associated with switching authority (Remote or Local), and by the operating mode (interlocked/non-interlocked, with or without password request).

Processing of interlocking conditions for switching (e.g. switchgear interlocking) can be established with the aid of integrated, user-configurable logic functions.

Messages and Measured Values; Recording of Event and Fault Data

The operational indications provide information about conditions in the power system and the device. Measurement quantities and values that are calculated can be displayed locally and communicated via the serial interfaces.

Device messages can be assigned to a number of LEDs on the front cover (allocatable), can be externally processed via output contacts (allocatable), linked with user-definable logic functions and/or issued via serial interfaces.

During a fault (system fault) important events and changes in conditions are saved in fault protocols (Event Log or Trip Log). Instantaneous fault values are also saved in the device and may be analyzed subsequently.

Communication

The following interfaces are available for communication with external operating, control and memory systems.

The USB DIGSI interface on the front cover serves for local communication with a PC. By means of the SIPROTEC 4 operating software DIGSI, all operational and evaluation tasks can be executed via this **operator** interface, such as specifying and modifying configuration parameters and settings, configuring user-specific logic functions, retrieving operational messages and measured values, inquiring device conditions and measured values, issuing control commands.

Depending on the ordered variant, additional interfaces are located at the bottom of the device. They serve for establishing extensive communication with other digital operating, control and memory components:

Port A serves for DIGSI communication directly on the device or via network. Furthermore, 2 SICAM I/O units 7XV5673 can be connected to this port. **Port A** can also be used for time synchronization using the NTP protocol.

Port B serves for central communication between the device and a control center. It can be operated via data lines or fiber optic cables. For the data transfer, there are standard protocols in accordance with IEC 60870-5-103 available. The integration of the devices into the SINAUT LSA and SICAM automation systems can also be implemented with this profile.

Alternatively, additional connection options are available with PROFIBUS DP and the DNP3.0 and MODBUS protocols. If an EN100 module is available, you can use the protocols IEC61850, PROFINET or DNP3 TCP. Furthermore, connecting a SICAM I/O unit is possible via IEC61850 GOOSE.

1.3 Characteristics

General Characteristics

- Powerful 32-bit microprocessor system
- Complete digital processing and control of measured values, from the sampling of the analog input quantities to the initiation of outputs, for example, tripping or closing circuit breakers or other switchgear devices
- Total electrical separation between the internal processing stages of the device and the external transformer, control, and DC supply circuits of the system because of the design of the binary inputs, outputs, and the DC or AC converters
- Complete set of functions necessary for the proper protection of lines, feeders, motors, and busbars
- Easy device operation through an integrated operator panel or by means of a connected personal computer running DIGSI
- Continuous calculation and display of measured and metered values on the front of the device
- Storage of min./max. measured values (slave pointer function) and storage of long-term mean values
- Storing fault indications for the last 8 power system faults (faults in the power system) with real-time assignment and instantaneous values for fault recording for a maximum time period of approx. 18 s
- Constant monitoring of the measured quantities, as well as continuous self-diagnostics covering the hardware and software
- Communication with SCADA or substation controller equipment via serial interfaces through the choice of data cable, modem, or optical fibers
- Battery-buffered clock which can be synchronized via a synchronization signal at the binary input or via a protocol
- Switching statistics: Counting the number of trip commands initiated by the device, logging the currents of the last switch-off operation initiated by the device, and accumulating the eliminated short-circuit currents of each breaker pole
- Operating hours counter: Counting the operating hours of the protected object under load
- Commissioning aids such as connection and direction check, status indication of all binary inputs and outputs, easy testing of port B, and influencing of information at port B during test operation.

Time Overcurrent Protection 50, 51, 50N, 51N

- Three definite time overcurrent protective Elements and one inverse time overcurrent protective element for phase current and ground current I_N or summation current $3I_0$
- Two-phase operation of the overcurrent protection (I_A, I_C) is possible
- For inverse-time overcurrent protection, selection from various characteristics of different standards possible
- Blocking is possible, e.g. for reverse interlocking with any Element
- Instantaneous tripping by any Element is possible when switching onto a fault
- In-rush restraint with second harmonic current quantities.

Ground Fault Protection 50N, 51N

- Three definite time overcurrent protective elements and one inverse time overcurrent protective element applicable for grounded or high-resistance grounded systems
- For inverse-time overcurrent protection, selection from various characteristics of different standards

- In-rush restraint with second harmonic current quantities.
- Instantaneous tripping by any overcurrent Element upon switch onto fault is possible.

Directional Time Overcurrent Protection 67, 67N

- Three definite time overcurrent protection elements and one inverse time overcurrent protection element for the phase operate in parallel to the non-directional overcurrent elements. Their pickup values and time delays can be set independently of these.
- Direction determination with cross-polarized voltages and voltage memory and dynamically unlimited direction sensitivity
- Fault direction is calculated phase-selectively and separately for phase faults, ground faults and summation current faults.

Dynamic Cold Load Pick-up Function 50C, 50NC, 51C, 51NC, 67C, 67NC

- Dynamic changeover of time overcurrent protection settings, e.g. when cold load conditions are recognized
- Detection of cold load condition via circuit breaker position or current threshold.
- Activation via automatic reclosure (AR) is possible
- Activation also possible via binary input.

Single-Phase Overcurrent Protection

- Evaluation of the measured current via the sensitive ground current transformer
- Suitable as differential protection that includes the neutral point current on transformer side, generator side or motor side or for a grounded reactor set
- As tank leakage protection against abnormal leakage currents between transformer tanks and ground.

Voltage Protection 27, 59 (Global Standard)

- Two element undervoltage detection via the positive-sequence system of the voltages, phase-to-phase or phase-to-ground voltages
- Choice of current supervision for 27-1 and 27-2
- Separate two-element overvoltage detection of the largest voltages applied or detection of the positive or negative sequence component of the voltages
- Settable dropout ratio for all elements of the undervoltage and overvoltage protection.

Voltage Protection 27, 59 (CEI 0-16 Standard)

- CEI 0-16 is the italian technical standard for connection to MV network. It prescribes the protection functions to be provided at the connection point.
- Two element undervoltage detection via phase-to-phase voltages
- Overvoltage protection 59.S2 detection of the largest phase-to-phase voltages applied
- Overvoltage protection 59.S1 uses 10 minutes RMS voltage value as detection quantity
- Settable dropout ratio for all elements of the undervoltage and overvoltage protection.

Negative Sequence Protection 46

- Evaluation of the negative sequence component of the currents

- Two definite-time elements 46-1 and 46-2 and one inverse-time element 46-TOC; curves of common standards are available for 46-TOC.

Frequency Protection 81 O/U (Global Standard)

- Monitoring of falling below (f<) and/or exceeding (f>) with 4 frequency limits and time delays that are independently adjustable
- Insensitive to harmonics and abrupt phase angle changes
- Adjustable undervoltage threshold.

Frequency Protection 81 O/U (CEI 0-16 Standard)

- CEI 0-16 is the Italian technical standard for connection to MV network. It prescribes the protection functions to be provided at the connection point.
- Monitoring of falling below (f<) and/or exceeding (f>) with 4 frequency limits and time delays that are independently adjustable
- Insensitive to harmonics and abrupt phase angle changes
- Adjustable undervoltage threshold.
- Voltmetric unblock feature 81V
- 59V0 trip element.
- Accelerated feature.

Undervoltage-controlled reactive power protection (27/Q)

- Detection of critical power system situations
- Disconnection of power supply facilities from the grid
- Reconnection under stable power system conditions

Thermal Overload Protection 49

- Thermal profile of energy losses (overload protection has full memory capability)
- True r.m.s. calculation
- Adjustable thermal warning element
- Adjustable alarm level based on current magnitude

Monitoring Functions

- Increased reliability due to monitoring of the internal measurement circuits as well as the hardware and software
- Fuse failure monitor with protection function blocking
- Monitoring of the current transformer and voltage transformer secondary circuits using sum and symmetry supervision with optional protection function blocking
- Trip circuit monitoring possible
- Phase rotation check.

Ground Fault Detection 50N(s), 51N(s), 67N(s), 59N/64

- Displacement voltage is measured or calculated from the three phase voltages.
- Determination of a faulty phase on ungrounded or grounded systems.
- Two-element ground fault detection: High-current element 50Ns-2 and overcurrent element 50Ns-1.
- High sensitivity (as low as 1 mA)
- Overcurrent element with definite time or inverse time delay.
- For inverse-time overcurrent protection, a user-defined characteristic is available.
- Direction determination with zero sequence quantities(I_0 , V_0), wattmetric ground fault direction determination.
- A sector characteristic can be set as directional characteristic
- Any Element can be set as directional or non-directional — forward sensing directional, or reverse sensing directional
- Optionally applicable as additional ground fault protection.

Intermittent Ground Fault Protection

- Detects and accumulates intermittent ground faults
- Tripping after configurable total time.

Directional intermittent ground fault protection

- Detects intermittent ground faults
- Direction determination
- Tripping after settable number of intermittent restrikes

Automatic Reclosing 79

- Single-shot or multi-shot
- With separate dead times for the first three and all subsequent shots
- Protective elements that initiate automatic reclosing are selectable. The choices can be different for phase faults and ground faults
- Separate programs for phase and ground faults
- Interaction to time overcurrent protection element and ground fault elements. They can be blocked in dependence of the reclosing cycle or released instantaneously
- Synchronous reclosing is possible in combination with the integrated synchrocheck function.

Fault Location

- Initiation by trip command, external command or dropout of pickup
- Configuration of up to three line sections possible
- Calculation of the fault distance and output of the fault location in ohms (primary and secondary) and in kilometers or miles

Breaker Failure Protection 50 BF

- By checking the current and/or evaluating the circuit breaker auxiliary contacts

- Started by any integrated protection function that trips
- Initiation possible via a binary input from an external protective device.

Flexible Protective Functions

- Up to 20 customizable protection functions with three-phase or single-phase operation
- Any calculated or directly measured quantity can be evaluated on principle.
- Standard protection logic with a constant (i.e. definite-time) characteristic curve
- Internal and configurable pickup and dropout delay
- Modifiable message texts.

Synchrocheck

- Verification of the synchronous conditions before reclosing after three-pole tripping
- Fast measurement of the voltage difference ΔV , the phase angle difference $\Delta\varphi$ and the frequency difference Δf
- Alternatively, check of the de-energized state before reclosing
- Setable minimum and maximum voltage
- Verification of the synchronous conditions or de-energized state also possible before the manual closing of the circuit breaker, with separate limit values
- Measurement also possible via transformer without external intermediate matching transformer
- Measuring voltages optionally phase-to-phase or phase-to-Ground.

Phase Rotation

- Selectable ABC or ACB by setting (static) or binary input (dynamic).

Circuit-Breaker Maintenance

- Statistical methods to help adjust maintenance intervals for CB contacts according to their actual wear
- Several independent subfunctions have been implemented (ΣI procedure, ΣI^x procedure, 2P procedure and I^2t procedure)
- Acquisition and conditioning of measured values for all subfunctions operates phase-selective using one procedure-specific threshold per subfunction.

User Defined Functions

- Freely programmable linking of internal and external signals in order to implement user-defined logic functions.
- All standard logic functions (AND, OR, NOT, EXCLUSIVE-OR, etc.)
- Time delays and limit value interrogations
- Processing of measured values, including zero suppression, adding a knee curve for a transducer input, and live-zero monitoring.

Breaker Control

- Switching devices can be opened and closed manually using control keys, programmable function keys, via port B (e.g. of SICAM or LSA), or via the user interface (using a personal computer and the DIGSI operating software)
- Feedback of switching states via the switch auxiliary contacts
- Plausibility monitoring of the circuit breaker position and check of interlocking conditions.



Functions

2

This chapter describes the numerous functions available on the SIPROTEC 4 device 7SJ80. It shows the setting possibilities for each function in maximum configuration. Information with regard to the determination of setting values as well as formulas, if required, are also provided.

Based on the following information, it can also be determined which of the provided functions should be used.

2.1	General	32
2.2	Overcurrent Protection 50, 51, 50N, 51N	68
2.3	Directional Overcurrent Protection 67, 67N	96
2.4	Dynamic Cold Load Pickup	122
2.5	Single-Phase Overcurrent Protection	128
2.6	Voltage Protection 27, 59	138
2.7	Negative Sequence Protection 46	160
2.8	Frequency Protection 81 O/U	167
2.9	Undervoltage-controlled reactive power protection (27/Q)	180
2.10	Thermal Overload Protection 49	185
2.11	Monitoring Functions	191
2.12	Ground Fault Protection 64, 67N(s), 50N(s), 51N(s)	211
2.13	Intermittent Ground Fault Protection	233
2.14	Dir. Intermittent earth fault protection	240
2.15	Automatic Reclosing System 79	245
2.16	Fault Locator	269
2.17	Breaker Failure Protection 50BF	272
2.18	Flexible Protection Functions	278
2.19	Reverse-Power Protection Application with Flexible Protection Function	291
2.20	Synchrocheck	299
2.21	Phase Rotation	313
2.22	Function Logic	315
2.23	Auxiliary Functions	317
2.24	Breaker Control	341
2.25	Notes on Device Operation	353

2.1 General

The settings associated with the various device functions can be modified using the operating or service interface in DIGSI in conjunction with a personal computer. Some parameters can also be changed using the controls on the front panel of the device. The procedure is described in detail in the SIPROTEC System Description .1/

2.1.1 Functional Scope

The 7SJ80 relay comprises protection functions and additional functions. The hardware and firmware are designed for this scope of functions. Additionally, the control functions can be matched to the system requirements. Individual functions can be activated or deactivated during the configuration procedure or the interaction of functions be modified.

2.1.1.1 Description

Setting the Scope of Functions

Example for the configuration of the scope of functions:

A system consists of overhead lines and underground cables. Since automatic reclosing is only needed for the overhead lines, the automatic reclosing function is disabled for the relays protecting the underground cables.

The available protection functions and additional functions can be configured as **Enabled** or **Disabled**. For some functions, there is a choice between several alternatives possible, as described below.

Functions configured as **Disabled** are not processed in the 7SJ80. There are no messages issued and the corresponding settings (functions, limit values) are not queried during configuration.



Note

Available functions and default settings depend on the ordered variant of the relay (see A.1 for details).

2.1.1.2 Setting Notes

Setting the Functional Scope

Your protection device is configured using the DIGSI software. Connect your personal computer either to the USB port on the device front or to port A or port B on the bottom side of the device depending on the device version (ordering code). The operation via DIGSI is explained in the SIPROTEC 4 System Description.

The **Device Configuration** dialog box allows you to adjust your device to the specific system conditions.

Password no. 7 is required (for parameter set) for changing configuration parameters in the device. Without the password the settings can only be read but not edited and transmitted to the device.

Special Features

Most settings are self-explanatory. The special cases are described in the following.

If you want to use the setting group change function, set address 103 **Grp Chge OPTION** to **Enabled**. In this case, you can select up to four different groups of function parameters between which you can switch quickly and conveniently during operation. Only **one** setting group can be used when selecting the option **Disabled**.

For the elements associated with non-directional overcurrent protection 50(N), 51(N) (phase and ground), various tripping characteristics can be selected at addresses 112 **Charac. Phase** and 113 **Charac. Ground**. If only the definite time Curve is desired, select **Definite Time**. Alternatively, you can select between inverse-time curves according to IEC standard (**TOC IEC**) or ANSI standard (**TOC ANSI**). The dropout behavior of the IEC and ANSI curves is specified at address 1210 or 1310 when configuring the time overcurrent protection.

Set to **Disabled** to disable the entire time overcurrent protection.

The directional overcurrent protection 67(N) is set at address 115 **67/67-TOC** and 116 **67N/67N-TOC**. Here, the same options are available as for non-directional overcurrent protection (except the 50-3 element).

For (sensitive) ground fault detection address 130 **S.Gnd.F.Dir.Ch** lets you specify the directional characteristic of the sensitive ground fault detection. You can select between **cos φ / sin φ** and **VO/IO φ mea.** as the measurement procedure. The **cos φ / sin φ** procedure (via residual wattmetric current detection) is set by default.

If the measuring method **cos φ / sin φ** is set, select between a definite time characteristic (**Definite Time**) and an inverse time characteristic **User Defined PU** at address 131 **Sens. Gnd Fault. VO/IO φ mea.** provides the definite time characteristic **Definite Time**, inverse time characteristics **TOC IEC** or **TOC ANSI**. When selecting the setting **Disabled**, the entire function is disabled.

For the intermittent ground fault protection, you can specify the measured quantity (**with Ignd, with 3IO** or **with Ignd, sens.**) to be used by this protection function at address 133 **INTERM.EF**.

At address 134 **Dir. Interm. EF** you can set the directional intermittent ground fault protection to **Enabled** or **Disabled**.

For unbalanced load protection, address 140 **46** allows you to specify which tripping characteristics to use. You can select between **Definite Time**, **TOC ANSI** or **TOC IEC**. If this function is not required, select **Disabled**.

The overload protection is activated in address 142 **49** by selecting the setting without ambient temperature **No ambient temp** or it is set to **Disabled**.

At address 155 **27/Q-Protection** you can set the QU protection to **Enabled** or **Disabled**.

The synchronization function is activated in address 161 **25 Function 1** by the setting **SYNCHROCHECK** or it is set to **Disabled**.

In address 170 you can set the breaker failure protection to **Enabled** or **Disabled**. The setting option **enabled w/ 3IO** subjects the ground current and the negative sequence current to a plausibility check.

For the CB maintenance functions, several options are available under address 172 **52 B.WEAR MONIT**. Irrespective of this, the basic functionality of the summation current formation (ΣI procedure) is always active. It requires no further configurations and adds up the tripping currents of the trips initiated by the protection functions.

When selecting the ΣI^2 -Procedure, the sum of all tripping current powers is formed and output as reference value. The **2P Procedure** continuously calculates the remaining lifespan of the circuit breaker.

With the I^2t Procedure the square fault current integrals are formed via arc time and output as a reference value.

Further information concerning the individual procedures of the CB maintenance are given in Section 2.23.2. You can also disable this function by setting it to **Disabled**.

In address 181, you can enter how many line sections (maximum of three) are taken into account by the fault locator.

Under address 182 **74 Trip Ct Supv** it can be selected whether the trip-circuit supervision works with two (**2 Binary Inputs**) or only one binary input (**1 Binary Input**), or whether the function is configured **Disabled**.

In address 192 **Cap. Volt.Meas.** you can specify whether you want to employ capacitive voltage measurement. When selecting **YES**, you have to specify the bushing capacitance, the line and stray capacitance for the capacitive voltage dividers at the voltage inputs in addresses 241 to 246 (see 2.1.3.2).

With capacitive voltage measurement several functions are not available or only partly. See table 2-2 in section 2.1.3.2 for more information regarding this topic.

In address 617 **ServiProt (CM)** you can specify for which purpose port B is used. **T103** means that the device is connected to a control and protection facility via serial port, **DIGSI** means that you are using the port to connect DIGSI or you are not using port B (**Disabled**).

The flexible protection functions can be configured via parameter **FLEXIBLE FUNC..** You can create up to 20 flexible functions by setting a checkmark in front of the desired function (an example is given in the section 2.19). If the checkmark of a function is removed, all settings and configurations made previously will be lost. After re-selecting the function, all settings and configurations are in default setting. Setting of the flexible function is done in DIGSI under „Settings“, „Additional Functions“ and „Settings“. The configuration is done, as usual, under „Settings“ and „Masking I/O (Configuration Matrix)“.

2.1.1.3 Settings

Addr.	Parameter	Setting Options	Default Setting	Comments
103	Grp Chge OPTION	Disabled Enabled	Disabled	Setting Group Change Option
104	OSC. FAULT REC.	Disabled Enabled	Enabled	Oscillographic Fault Records
112	Charac. Phase	Disabled Definite Time TOC IEC TOC ANSI	Definite Time	50/51
112	Charac. Phase	Disabled Definite Time TOC IEC TOC ANSI	Disabled	50/51 (For CEI 0-16)
113	Charac. Ground	Disabled Definite Time TOC IEC TOC ANSI	Definite Time	50N/51N
113	Charac. Ground	Disabled Definite Time TOC IEC TOC ANSI	Disabled	50N/51N (For CEI 0-16)
115	67/67-TOC	Disabled Definite Time TOC IEC TOC ANSI	Definite Time	67, 67-TOC
116	67N/67N-TOC	Disabled Definite Time TOC IEC TOC ANSI	Definite Time	67N, 67N-TOC

Addr.	Parameter	Setting Options	Default Setting	Comments
116	67N/67N-TOC	Disabled Definite Time TOC IEC TOC ANSI	Disabled	67N, 67N-TOC (For CEI 0-16)
117	Coldload Pickup	Disabled Enabled	Disabled	Cold Load Pickup
122	InrushRestraint	Disabled Enabled	Disabled	2nd Harmonic Inrush Restraint
127	50 1Ph	Disabled Enabled	Disabled	50 1Ph
130	S.Gnd.F.Dir.Ch	cos φ / sin φ V0/I0 φ mea.	cos φ / sin φ	(sens.) Ground fault dir. characteristic
130	S.Gnd.F.Dir.Ch	cos φ / sin φ V0/I0 φ mea.	V0/I0 φ mea.	(sens.) Ground fault dir. characteristic (For CEI 0-16)
131	Sens. Gnd Fault	Disabled Definite Time User Defined PU	Disabled	(sensitive) Ground fault
133	INTERM.EF	Disabled with Ignd with 3I0 with Ignd,sens.	Disabled	Intermittent earth fault protection
134	Dir. Interm. EF	Disabled Enabled	Disabled	Dir. Intermittent earth fault protection
140	46	Disabled TOC ANSI TOC IEC Definite Time	Disabled	46 Negative Sequence Protection
142	49	Disabled No ambient temp	No ambient temp	49 Thermal Overload Protection
142	49	Disabled No ambient temp	Disabled	49 Thermal Overload Protection (For CEI 0-16)
150	27/59	Disabled Enabled	Disabled	27, 59 Under/Overvoltage Protection
150	27/59	Disabled Enabled	Enabled	27, 59 Under/Overvoltage Protection (For CEI 0-16)
154	81 O/U	Disabled Enabled	Disabled	81 Over/Underfrequency Protection
154	81 O/U	Disabled Enabled	Enabled	81 Over/Underfrequency Protection (For CEI 0-16)
155	27/Q-Protection	Disabled Enabled	Disabled	27 / Q dir. con. Protection
161	25 Function 1	Disabled SYNCHROCHECK	Disabled	25 Function group 1
170	50BF	Disabled Enabled enabled w/ 3I0>	Disabled	50BF Breaker Failure Protection
171	79 Auto Recl.	Disabled Enabled	Disabled	79 Auto-Reclose Function
172	52 B.WEAR MONIT	Disabled I _x -Method 2P-Method I _{2t} -Method	Disabled	52 Breaker Wear Monitoring

Addr.	Parameter	Setting Options	Default Setting	Comments
180	Fault Locator	Disabled Enabled	Disabled	Fault Locator
181	L-sections FL	1 Section 2 Sections 3 Sections	1 Section	Line sections for fault locator
182	74 Trip Ct Supv	Disabled 2 Binary Inputs 1 Binary Input	Disabled	74TC Trip Circuit Supervision
192	Cap. Volt.Meas.	NO YES	NO	Capacitive voltage measurement
617	ServiProt (CM)	Disabled T103 DIGSI	T103	Port B usage
-	FLEXIBLE FUNC. 1...20	Flex. Function 01 Flex. Function 02 Flex. Function 03 Flex. Function 04 Flex. Function 05 Flex. Function 06 Flex. Function 07 Flex. Function 08 Flex. Function 09 Flex. Function 10 Flex. Function 11 Flex. Function 12 Flex. Function 13 Flex. Function 14 Flex. Function 15 Flex. Function 16 Flex. Function 17 Flex. Function 18 Flex. Function 19 Flex. Function 20	Please select	Flexible Functions

2.1.2 Device, General Settings

The device requires some general information. This may be, for example, the type of annunciation to be issued in the event of an occurrence of a power system fault.

2.1.2.1 Description

Command-Dependent Messages "No Trip – No Flag"

The storage of indications assigned to local LEDs and the availability of spontaneous indications can be made dependent on whether the device has issued a trip command. This information is then not issued if during a system disturbance one or more protection functions have picked up but the 7SJ80 did not trip because the fault was cleared by another device (e.g. on another line). These messages are then limited to faults in the line to be protected.

The following figure illustrates the generation of the reset command for stored indications. The instant the device drops out, the presetting of parameter 610 **FltDisp.LED/LCD** decides whether the new fault remains stored or is reset.

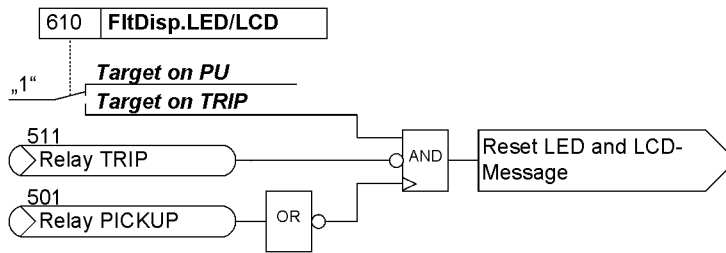

Figure 2-1 Creation of the reset command for the latched LED and LCD messages

Spontaneous Messages on the Display

You can determine whether or not the most important data of a fault event is displayed automatically after the fault has occurred (see also Subsection "Fault Messages" in Section "Auxiliary Functions").

2.1.2.2 Setting Notes

Fault Display

A new pickup by a protection element generally turns off any previously lit LEDs so that only the latest fault is displayed at any one time. It can be selected whether the stored LED displays and the spontaneous fault indications on the display appear upon the new pickup, or only after a new trip signal is issued. In order to select the desired displaying mode, select the submenu Device in the SETTINGS menu. Under address 610 **FltDisp.LED/LCD** the two alternatives **Target on PU** and **Target on TRIP** ("No trip – no flag") can be selected.

Use parameter 611 **Spont. FltDisp.** to specify whether or not a spontaneous fault message should appear automatically on the display (**YES**) or not (**NO**).

Selection of Default Display

The start page of the default display appearing after startup of the device can be selected in the device data via parameter 640 **Start image DD**. The pages available for each device version are listed in the Appendix A.5.

Time Synchronization via Port A

If you want the time synchronization of the device to be performed via port A, set the parameters required for this purpose at the following addresses:

- Address 660 **IP adr[0](Prim)** through 663 **IP adr[3](Prim)** IP addresses 0 to 3, NTP primary
- address 664 **IP adr[0](Sec)** through 667 **IP adr[3](Sec)** IP addresses 0 to 3, NTP secondary
- address 668 **Client activ** client for primary and secondary addresses switched on or off.
- Address 669 **Daylight Set** daylight saving time switched on or off.
- Address 670 **Offset TZ/min** offset for the time zone in minutes
- Address 671 **Offset DayT/min** offset for daylight saving time in minutes
- Address 672 **W2S month** through 675 **W2S hour** month, week (of the month), day of the week, hour of switching to daylight saving time
- address 676 **S2W month** through 679 **S2W hour** month, week (of the month), day of the week, hour of switching to winter time

Access authorization for port A

At address 651 **ParEN100 (LC) blk** you can parameterize a **read** access option via the EN100 module at port A. If the parameter is set to **ON**, you can read out the device parameters using DIGSI or fetch fault records.

IEC 61850 GOOSE Function

At address 700 **GOOSE - Stop** you can set the GOOSE function of the IEC 61850 protocol to active or not. If **GOOSE - Stop** is set to **YES**, you can release the GOOSE function again via a binary input during operation.

2.1.2.3 Settings

Addr.	Parameter	Setting Options	Default Setting	Comments
132	GND CT Scaling	Sensitive Normal	Normal	Ground CT Scaling
610	FltDisp.LED/LCD	Target on PU Target on TRIP	Target on PU	Fault Display on LED / LCD
611	Spont. FltDisp.	YES NO	NO	Spontaneous display of flt.annunciations
640	Start image DD	image 1 image 2 image 3 image 4 image 5 image 6	image 1	Start image Default Display
651	ParEN100(LC)blk	OFF ON	OFF	DIGSI-config. over EN100 (LC) blocked
660	IP adr[0](Prim)	0 .. 255	0	IP address [0] (NTP-Primary)
661	IP adr[1](Prim)	0 .. 255	0	IP address [1] (NTP-Primary)
662	IP adr[2](Prim)	0 .. 255	0	IP address [2] (NTP-Primary)
663	IP adr[3](Prim)	0 .. 255	0	IP address [3] (NTP-Primary)
664	IP adr[0] (Sec)	0 .. 255	0	IP address [0] (NTP-Sekundary)
665	IP adr[1] (Sec)	0 .. 255	0	IP address [1] (NTP-Sekundary)
666	IP adr[2] (Sec)	0 .. 255	0	IP address [2] (NTP-Sekundary)
667	IP adr[3] (Sec)	0 .. 255	0	IP address [3] (NTP-Sekundary)
668	Client activ	OFF ON	OFF	Client activ
669	Daylight Set	OFF ON	OFF	Daylight Set
670	Offset TZ/min	-1440 .. 1440 min	60 min	Offset for time zone in minutes
671	Offset DayT/min	-1440 .. 1440 min	60 min	Offset for daylight in minutes
672	W2S month	1 .. 12	3	month of time set winter to summer
673	W2S week	1 .. 5	5	week of time set winter to summer

Addr.	Parameter	Setting Options	Default Setting	Comments
674	W2S day	Monday Tuesday Wednesday Thursday Friday Saturday Sunday	Sunday	day of time set winter to summer
675	W2S hour	1 .. 24	2	hour of time set winter to summer
676	S2W month	1 .. 12	10	month of time set summer to winter
677	S2W week	1 .. 5	5	week of time set summer to winter
678	S2W day	Monday Tuesday Wednesday Thursday Friday Saturday Sunday	Sunday	day of time set summer to winter
679	S2W hour	1 .. 24	3	hour of time set summer to winter
700	GOOSE-Stop	YES NO	NO	GOOSE-Stop

2.1.2.4 Information List

No.	Information	Type of Information	Comments
-	>Light on	SP	>Back Light on
-	Reset LED	IntSP	Reset LED
-	DataStop	IntSP	Stop data transmission
-	Test mode	IntSP	Test mode
-	Feeder gnd	IntSP	Feeder GROUNDED
-	Brk OPENED	IntSP	Breaker OPENED
-	HWTestMod	IntSP	Hardware Test Mode
-	SynchClock	IntSP_Ev	Clock Synchronization
-	Distur.CFC	OUT	Disturbance CFC
1	Not configured	SP	No Function configured
2	Non Existent	SP	Function Not Available
3	>Time Synch	SP_Ev	>Synchronize Internal Real Time Clock
5	>Reset LED	SP	>Reset LED
15	>Test mode	SP	>Test mode
16	>DataStop	SP	>Stop data transmission
51	Device OK	OUT	Device is Operational and Protecting
52	ProtActive	IntSP	At Least 1 Protection Funct. is Active
55	Reset Device	OUT	Reset Device
56	Initial Start	OUT	Initial Start of Device
67	Resume	OUT	Resume
68	Clock SyncError	OUT	Clock Synchronization Error

No.	Information	Type of Information	Comments
69	DayLightSavTime	OUT	Daylight Saving Time
70	Settings Calc.	OUT	Setting calculation is running
71	Settings Check	OUT	Settings Check
72	Level-2 change	OUT	Level-2 change
73	Local change	OUT	Local setting change
110	Event Lost	OUT_Ev	Event lost
113	Flag Lost	OUT	Flag Lost
125	Chatter ON	OUT	Chatter ON
140	Error Sum Alarm	OUT	Error with a summary alarm
160	Alarm Sum Event	OUT	Alarm Summary Event
177	Fail Battery	OUT	Failure: Battery empty
178	I/O-Board error	OUT	I/O-Board Error
181	Error A/D-conv.	OUT	Error: A/D converter
191	Error Offset	OUT	Error: Offset
193	Alarm NO calibr	OUT	Alarm: NO calibration data available
194	Error neutralCT	OUT	Error: Neutral CT different from MLFB
232	CT ph mismatch	OUT	LPCT phase Current Transf. mismatching
233	CT gnd mismatch	OUT	LPCT ground Current Transf. mismatching
301	Pow.Sys.Flt.	OUT	Power System fault
302	Fault Event	OUT	Fault Event
303	sens Gnd flt	OUT	sensitive Ground fault
320	Warn Mem. Data	OUT	Warn: Limit of Memory Data exceeded
321	Warn Mem. Para.	OUT	Warn: Limit of Memory Parameter exceeded
322	Warn Mem. Oper.	OUT	Warn: Limit of Memory Operation exceeded
323	Warn Mem. New	OUT	Warn: Limit of Memory New exceeded
335	>GOOSE-Stop	SP	>GOOSE-Stop
502	Relay Drop Out	SP	Relay Drop Out
510	Relay CLOSE	SP	General CLOSE of relay
545	PU Time	VI	Time from Pickup to drop out
546	TRIP Time	VI	Time from Pickup to TRIP
10080	Error Ext I/O	OUT	Error Extension I/O
10081	Error Ethernet	OUT	Error Ethernet
10082	Error Terminal	OUT	Error Current Terminal
10083	Error Basic I/O	OUT	Error Basic I/O

2.1.3 Power System Data 1

2.1.3.1 Description

The device requires certain data regarding the network and substation so that it can adapt its functions to this data depending on the application. This may be, for instance, nominal data of the substation and measuring transformers, polarity and connection of the measured quantities, breaker properties (where applicable), etc. There are also certain parameters that are common to all functions, i.e. not associated with a specific protection, control or monitoring function. The following section discusses this data.

2.1.3.2 Setting Notes

General

Some **P.System Data 1** can be entered directly at the device. See section 2.25 for more information regarding this topic.

In DIGSI double-click **Settings** to open the corresponding dialog box. In doing so, a dialog box with tabs will open under **P.System Data 1** where individual parameters can be configured. The following descriptions are therefore structured according to these tabs.

Nominal Frequency (Power System)

The nominal frequency of the system is set under the Address 214 **Rated Frequency**. The factory pre-setting in accordance with the model need only be changed if the device will be employed for a purpose other than that which was planned when ordering. In the US device versions (ordering data position 10= C), parameter 214 is preset to 60 Hz.

Phase Rotation (Power System)

Address 209 **PHASE SEQ.** is used to change the default phase sequence (**A B C** for clockwise rotation) if your power system permanently has an anti-clockwise phase sequence (**A C B**). A temporary reversal of rotation is also possible using binary inputs (see Section 2.21.2).

Polarity of Current Transformers (Power System)

At address 201 **CT Starpoint**, the polarity of the wye-connected current transformers is specified (the following figure applies accordingly to two current transformers). This setting determines the measuring direction of the device (forward = line direction). Changing this parameter also results in a polarity reversal of the ground current inputs I_N or I_{NS} .

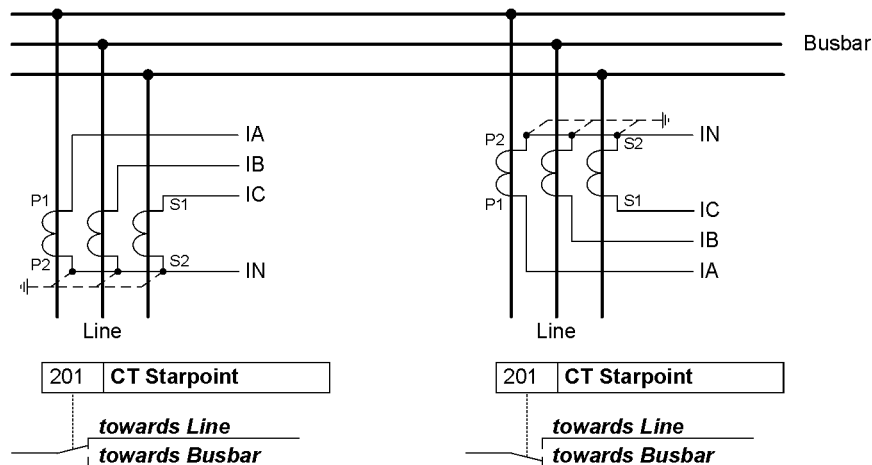

Figure 2-2 Polarity of current transformers

Current Connection I4 (Power System)

Here, it is communicated to the device whether the ground current of the current transformer neutral point is connected to the fourth current input (I_4). This corresponds to the Holmgren connection, (see connection example in Appendix A.3,A-7). In this case, parameter 280 **Holmgr. for Σi** is set to **YES**. In all other cases, even if the ground current of the own line is measured via a separate ground current transformer, enter the setting **NO**. This setting exclusively affects the function „Current Sum Monitoring“ (see Section 2.11.1).

Current Connection (Power System)

Via parameter 251 **CT Connect**, a special connection of the current transformers can be determined.

The standard connection is **A, B, C, (Gnd)**. It may only be changed if the device is set to measure one or more ground currents via two current inputs. The standard connection has to be used in all other cases.

The following picture illustrates such a special connection.

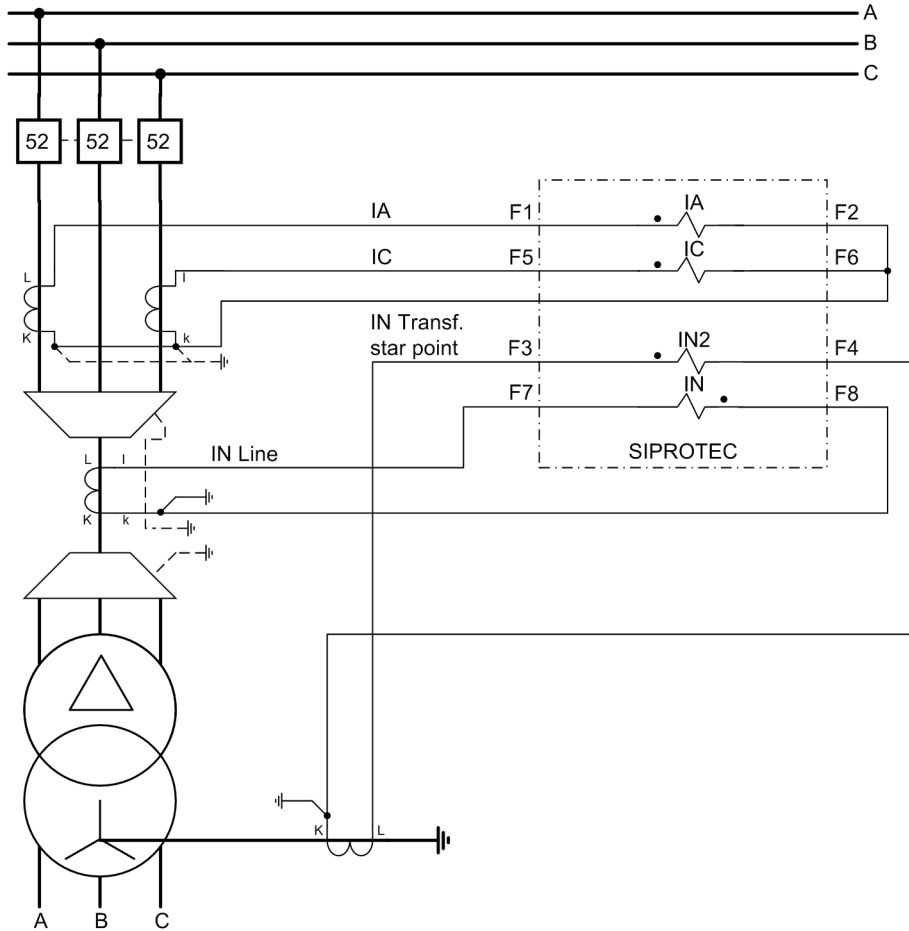

Figure 2-3 Measurement of two ground currents, example

The phase currents I_A and I_C must be connected to the first current input (terminals F1, F2) and to the third (terminals F5, F6). The ground current IN or INS is connected to the fourth input (terminals F7, F8) as usual, in this case the ground current of the line. A second ground current, in this case the transformer starpoint current, is connected to the second current input IN2 (terminals F3, F4).

The settings **A, G2, C, G; G -> B** or **A, G2, C, G; G2 -> B** are used here. They both define the connection of a ground current IN2 to the second current input (terminals F3, F4). The settings only differ in the calculation of I_B . In the case of **A, G2, C, G; G -> B**, the phase current I_B is determined from the phase currents I_A and I_C and from the measured ground current IN or INS at the fourth current input. In the case of **A, G2, C, G; G2 -> B**, the phase current I_B is determined from the phase currents I_A and I_C and from the measured ground current IN2 at the second current input. This setting is only possible for devices with sensitive ground current transformer. Therefore, the current IN2 at the second current input is referred to IN in the flexible protection functions and in the operational measured values. The sensitive ground current at the fourth current input is referred to INS. The setting must be selected according to the system requirements.

The following table gives an overview of how the protection functions are assigned to the ground current inputs for the special connection.

Function	Current input 2 (I_{N2})	Current input 4 (I_N or I_{Ns})
Time overcurrent protection ground 50N/51N (Section 2.2)	x	
Directional time overcurrent protection ground 67N (section 2.3)	x	
Ground fault detection 64, 67N(s), 50N(s), 51N(s) (Section 2.12)		x
Single-phase Time Overcurrent Protection (Chapter 2.5)		x
Operational Measured Values Display	IN	INs
Track in disturbance record	IN	INs

¹⁾ Important! The function „Directional Time Overcurrent Protection Ground 67N“ may only be enabled if the ground current of the protected line is measured via I_{N2} . This is not the case in the example shown in Figure 2-3. Here, the ground current of the protected line is measured via I_N . The function must be deactivated. A connection in which the function can be enabled is illustrated in the Appendix A.3 Figure A-18.

The settings for address 251 are only possible with DIGSI at **Display Additional Settings**.

The Appendix provides some connection examples at A.3.



Note

The settings in address 251 **CT Connect.** for evaluating the phase currents are only effective if address 250 **50/51 2-ph prot** was set to **OFF**.

Voltage Connection (Power System)

Address 213 specifies how the voltage transformers are connected.

VT Connect. 3ph = Van, Vbn, Vcn means that the three phase voltages are wye connected, i.e. the three phase-to-Ground voltages are measured.

VT Connect. 3ph = Vab, Vbc, VGnd means that two phase-to-phase voltages (open delta voltage) and the displacement voltage V_{GND} are connected.

VT Connect. 3ph = Vab, Vbc means that two phase-to-phase voltages (open delta voltage) are connected. The third voltage transformer of the device is not used.

VT Connect. 3ph = Vab, Vbc, Vx means that two phase-to-phase voltages (open delta voltage) are connected. Furthermore, any third voltage V_x is connected that is used exclusively for the flexible protection functions. The transformer nominal voltages for V_x are set at address 232 and 233.

VT Connect. 3ph = Vab, Vbc, VSyn means that two phase-to-phase voltages (open delta voltage) and the reference voltage for V_{SYN} are connected. This setting is enabled if the synchronization function of the device is used.

VT Connect. 3ph = Vph-g, VSyn is used if the synchronization function of the device is used and only phase-to-Ground voltages are available for the protected object to be synchronized. One of these voltages is connected to the first voltage transformer; the reference voltage V_{SYN} is connected to the third voltage transformer.

For CEI 0-16 standard (ordering data position 14= G), only **Vab, Vbc, VGnd** connection is available in 7SJ80, in this case parameter 213 only has one setting option **Vab, Vbc, VGnd**.

The selection of the voltage transformer connection affects the operation of all device functions that require voltage input.

The settings **Vab**, **Vbc** or **Vab**, **Vbc**, **Vx** or **Vab**, **Vbc**, **VSyn** or **Vph-g**, **VSyn** do not allow determining the zero sequence voltage. The associated protection functions are inactive in this case.

The table gives an overview of the functions that can be activated for the corresponding connection type (depends also on the ordering number). The functions which are not shown are available for all connection types.

Table 2-1 Connection Types of the Voltage Transformers

Connection type	Functions							
	Directional definite-time/inverse-time overcurrent protection phase	Directional definite-time/inverse-time overcurrent protection ground	Sensitive ground fault protection 50Ns, 51Ns, 67Ns	Synchronization	Fault locator	QU protection	Directional intermittent ground fault	Fuse failure monitor
Van, Vbn, Vcn	yes	yes	yes	no	yes	yes	yes	yes
Vab, Vbc, VGnd	yes	yes	yes	no	yes	yes	yes	yes
Vab, Vbc	yes	yes ¹⁾	yes ²⁾	no	no	yes	no	no
Vab, Vbc, Vx	yes	yes ¹⁾	yes ²⁾	no	no	yes	no	no
Vab, Vbc, VSyn	yes	no	yes ²⁾	yes	no	yes	no	no
Vph-g, VSyn	no	no	yes ²⁾	yes	no	No	no	no

1) Determination of the direction is only possible by evaluating the negative sequence system (otherwise select zero sequence system or negative sequence system).

2) With this type of voltage transformer connection the current elements operate only non-directional, the voltage elements do not work.

Measured values, which due to the chosen voltage connection cannot be calculated, will be displayed as dots.

If the connection of the protected object is capacitive (address 192, **Cap. Volt.Meas. YES**, parameter 213 is not displayed. The device will assume in this case that three phase-to-Ground voltages are connected (setting **Van**, **Vbn**, **Vcn**).

With capacitive voltage connection, some functions are not available. Table 2-2 gives information on this topic.

The Appendix provides some connection examples for all connection types at A.3.

Capacitive Voltage Measurement

When selecting capacitive voltage measurement in the Device Configuration at address 192 **Cap. Volt.Meas.**, the voltage will be measured via so-called bushing capacitances. The usual primary voltage transformers are not relevant in this case. Capacitive voltage measurement always measures the phase-to-Ground voltages from the protection device. The following figure shows this type of connection.

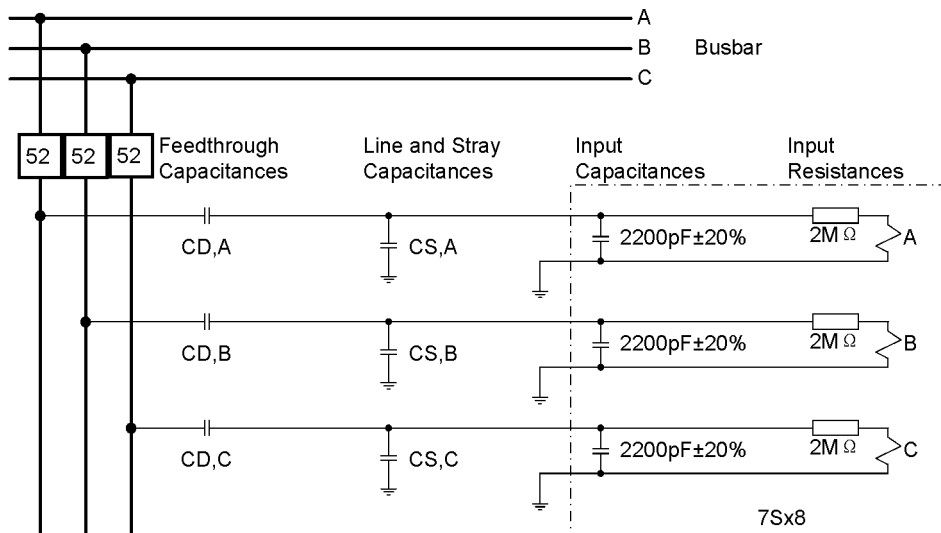

Figure 2-4 Connection for a capacitive voltage measurement in principle

In addition to the bushing capacitances, the line and stray capacitances too affect the measured voltage fed to the protection device. These capacitances are primarily determined by the type and length of the connection line.

The voltage inputs of the device feature an input capacitance of 2.2nF and an ohmic component of 2.0 MΩ.

Two capacitance values must be configured for each of the three voltage inputs when using capacitive voltage measurement.

- The first value to be configured is the bushing capacitance ($C_{D,Lx}$).
- The second value to be configured is the sum of the line and stray capacitance ($C_{S,Lx}$) and input capacitance (2200 pF).

Since the input capacitances can have a tolerance of $\pm 20\%$, they are not considered as a fixed value internally but they have to be configured (see also side heading „Optimizing the Configured Capacitance Values“).

The capacitances are configured as follows:

Phase A	241 Volt.trans.A:C1	= $C_{D,A}$
	242 Volt.trans.A:C2	= $C_{S,A} + 2200 \text{ pF}$
Phase B	243 Volt.trans.B:C1	= $C_{D,B}$
	244 Volt.trans.B:C2	= $C_{S,B} + 2200 \text{ pF}$
Phase C	245 Volt.trans.C:C1	= $C_{D,C}$
	246 Volt.trans.C:C2	= $C_{S,C} + 2200 \text{ pF}$

Boundary Conditions for the Capacitive Voltage Measurement

The voltages at the inputs of the protection devices are the result of the primary nominal voltage, the capacitances in the power system and the impedances of the voltage inputs which are taken into account. These voltages can assume different values for three voltage inputs. The voltage $V_{\text{secondary, } x}$ for phase x can be determined using the following formula:

$$V_{\text{sec, Lx}} = V_{\text{prim, Lx}} \cdot \frac{2\pi \cdot f \cdot 2.0 \text{ M}\Omega \cdot C_{\text{D, Lx}}}{\sqrt{1 + (2\pi \cdot f \cdot 2.0 \text{ M}\Omega \cdot (C_{\text{D, Lx}} + C_{\text{S, Lx}} + 2200 \text{ pF}))^2}}$$

with

- $V_{\text{prim, x}}$ Primary voltage of phase x
- $V_{\text{sec, x}}$ Voltage at the voltage input of the protection device
- $C_{\text{D, Lx}}$ Value of the bushing capacitance for phase x
- $C_{\text{S, Lx}}$ Value of the line and stray capacitance for phase x
- exec. System frequency (50 Hz or 60 Hz)

The following figure represents the above equation graphically. The frequency is 50 Hz. With a frequency of 60 Hz, the ratio of secondary voltage to primary voltage is about 20 % higher than the values in this example.

The x-axis shows the value of the bushing capacitance. The y-axis shows the resulting ratio of secondary voltage to primary voltage. As an additional parameter the value $C_{\text{S, Lx}} + 2200 \text{ pF}$, which is the sum of line capacitance, stray capacitance and input capacitance, is varied in a range from 2000 pF to 10,000 pF in increments of 500 pF. Since the input capacitance of 2200 pF can have a tolerance of $\pm 20\%$, values higher than 1800 pF are recommended here.

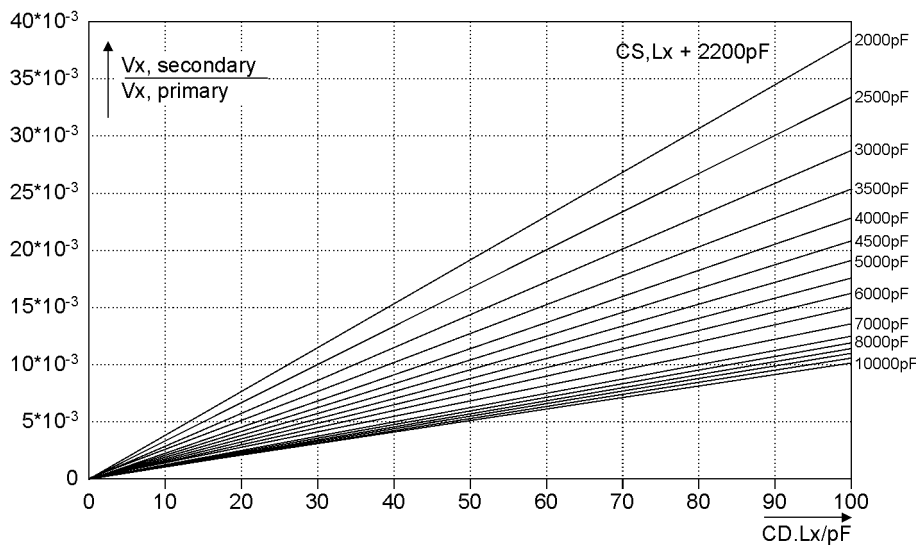

Figure 2-5 Capacitive voltage measurement

The device can fully function only if the secondary voltage that results from the nominal voltage on the primary side lies within a certain range. If the primary nominal voltage at the voltage inputs causes a too small or too high voltage, the function of the device will be blocked. This plausibility check is run each time the device starts up based on the configured parameter values for the primary nominal voltage and the configured capacitance values.



Note

The settings for the primary nominal voltage and the settings of the capacitance values must lead to a voltage between 34 V and 140 V on the secondary side (voltage inputs of the device) with nominal voltage on the primary side. Since the input voltages are phase-to-Ground voltages, the operational range for the input voltages is hence $34 \text{ V} / \sqrt{3}$ to $140 \text{ V} / \sqrt{3}$.

If this condition is not satisfied for at least one of the three voltage inputs, the device will generate the messages „Device Failure“ and 10036 „Capac . Par . Fail . “ after startup.



Note

Used bushing capacities have to be available exclusively to the connected 7Sx80. Connecting a parallel port, e.g. on a capacitive voltage measuring device, at the same bushing capacities is not allowed.

Internal Normalization of the Measured Voltages

The capacitance values for the three voltage inputs will usually not be absolutely identical. From this we can conclude that voltages identical on the primary side are mapped differently at the voltage inputs. The measured voltages are normalized by the device so that the three phase-to-Ground voltages can still be linked by calculation (e.g. to calculate the phase-to-phase voltages of the positive sequence system and of the negative sequence system etc.). This normalization has the effect that the primary nominal voltage in the device leads to voltage values that correspond to the configured secondary nominal voltage (parameter 203 **Vnom SECONDARY**) even though the real voltages at the input terminals are different.

The setting of parameter 203 **Vnom SECONDARY** should be roughly equivalent to the voltage at the terminals of the protection device at primary nominal voltage. If capacitive voltage measurement is selected, a setting range of 34 V to 140 V is sufficient for this parameter.

Optimizing the Configured Capacitance Values

In many cases the exact values for the bushing capacitance and for the line and stray capacitance will be unknown. Besides that the capacitance of the voltage inputs has a tolerance of $\pm 20 \%$.

These uncertainties can cause amplitude and phase errors of the measured voltage.

If the primary voltage is known, the value for the bushing capacitance ($C_{D,x}$) to be configured can still be optimized later. This is based on the fact that an incorrect configuration of the bushing capacitance usually affects the secondary voltage value and not so much the phase angle. We can gain insight into the amplitude error by comparing the primary phase-to-Ground voltages in the operational measured values with their setpoint values. The value of the configured bushing capacitance should be increased by the percentage that the displayed phase-to-Ground voltage is too large or it should be reduced by the percentage that the displayed phase-to-Ground voltage is too small.

If the phase angle of the primary voltage to the primary current is known, the setting value for the sum of line capacitance and stray capacitance ($C_{S,x}$) and input capacitance can still be optimized later. This is based on the fact that these capacitances usually affect the phase angle of the secondary voltage and not so much the amplitude. We can gain insight into the phase errors by comparing the phase angles (φ_A , φ_B and φ_C) in the operational measured values with their setpoint values. The configured value must be corrected by 4 % per degree angle error (actual angle less desired angle). If the angle error is positive, the configured value has to be reduced accordingly; if the angle error is negative it has to be increased accordingly. The prerequisite for the phase angle between phase-to-Ground voltage and phase current to be displayed is that the current amounts to at least 10 % of the nominal value.

The optimization steps for the capacitances to be configured for each voltage channel may have to be repeated until the desired accuracy has been achieved.

Influence of the Capacitive Voltage Measurement

The following table shows how the capacitive voltage measurement affects the voltage-dependent device functions.

Table 2-2 Influence of the Capacitive Voltage Measurement

Function	Effect
Directional Time Overcurrent Protection 67, 67N	operational
Voltage protection 27, 59	operational Please observe the increased tolerances of the measured voltage.
Ground fault detection 64, 50Ns, 67Ns	The voltage elements are not available. The current elements always operate non-directional.
Frequency protection 81 O/U	operational
Synchrocheck	not operational
Flexible protection functions	Operating modes that use the power are not available.
Fault locator	not operational
Fuse failure monitor	not operational
Operational measured values	Power and energy not available

Distance Unit (Power System)

Address 215 **Distance Unit** allows you to specify the distance unit (*km* or *Miles*) for the fault locator. In the absence of a fault locator or if this function has been removed, this parameter is of no importance. Changing the distance unit does not imply an automatic conversion of the setting values that are dependent on the distance unit. These have to be re-entered at the respective addresses.

ATEX100 (Power System)

Parameter 235 **ATEX100** enables meeting the requirements for protecting explosion-protected motors for thermal replicas. Set this parameter to **YES** to save all thermal replicas of the 7SJ80 devices in the event of a power supply failure. After the supply voltage is restored, the thermal replicas will resume operation using the stored values. Set the parameter to **NO**, to reset the calculated overtemperature values of all thermal replicas to zero if the power supply fails.

Static Generator (Power System)

At address 616 **STATIC GEN.**, the type of the generator is specified (the following figure applies accordingly to two generators). This setting is relevant only for CEI 0-16 application. Refer to chapter 2.6.2 for further details.

In CEI 0-16 standard, in case of transformers / transducers for frequency / voltage measurement installed downstream the DDI (generator side), all the PI functions are blocked by ">DDI Open". For Static or not self-excited asynchronous generators, at the closure of the DDI, 81>.S2, 81<.S2, 59V0 will be accelerated by removing the ">DDI Open" signal. To do so, parameter 616 **STATIC GEN.** must be set to YES. For other generators, parameter 616 **STATIC GEN.** is set to **NO**, 81>.S2, 81<.S2, 59V0 will not be accelerated by ">DDI Open" removal.

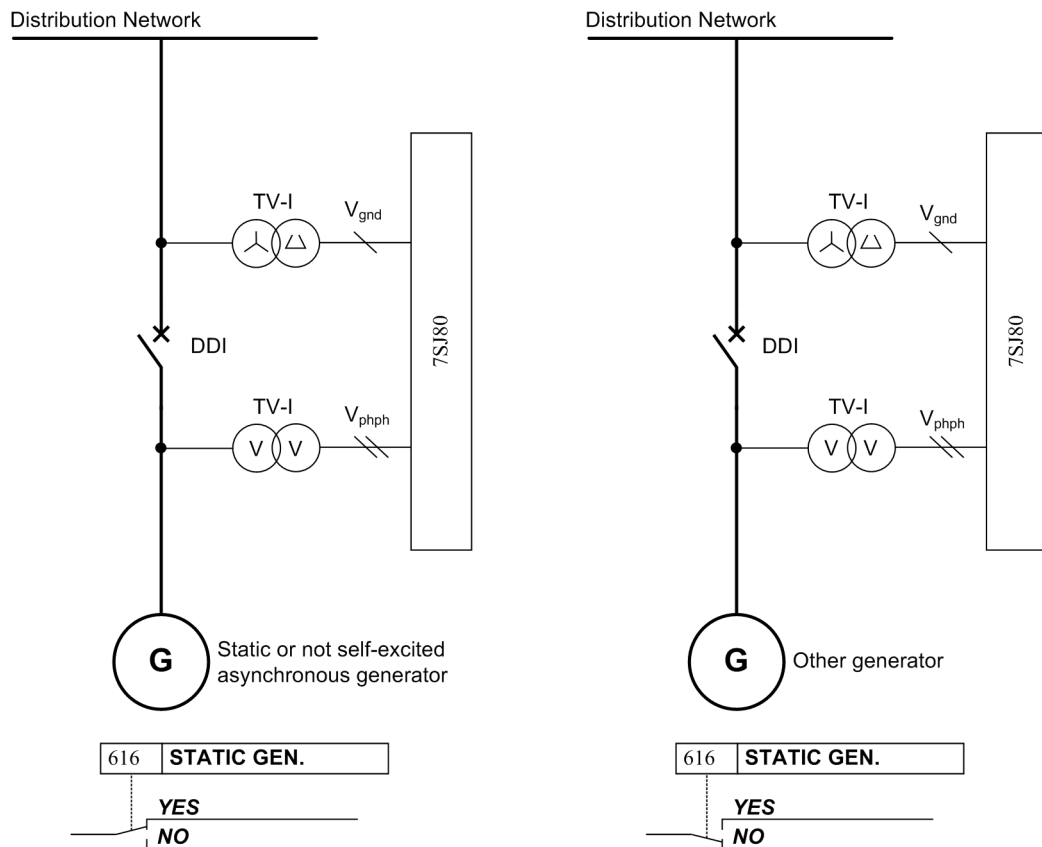

Figure 2-6 Static Generator



Note

DDI is a kind of circuit breaker in CEI 0-16 standard.

TV-I is inductive voltage transformers / transducers, in compliance with CEI EN 60044-2.

PI functions include 27, 59, 59V0, 81, direct trip

Nominal Values of Current Transformers (CTs)

At addresses 204 **CT PRIMARY** and 205 **CT SECONDARY** information is entered regarding the primary and secondary ampere ratings of the current transformers. It is important to ensure that the rated secondary current of the current transformer matches the rated current of the device, otherwise the device will calculate incorrect primary data. At addresses 217 **I_{gnd}-CT PRIM** and 218 **I_{gnd}-CT SEC**, information is entered regarding the primary and secondary ampere rating of the current transformers. In case of a normal connection (starpoint current connected to I_N transformer), 217 **I_{gnd}-CT PRIM** and 204 **CT PRIMARY** must be set to the same value.

If the device features a sensitive ground current input, parameter 218 **I_{gnd}-CT SEC** is set to 1 A.

For US device models (order item 10= C) parameters 205 and 218 are set by default to 5 A.

If address 251 **CT Connect .** has been set so that ground currents are measured by two inputs (setting options **A, G2, C, G; G -> B** or **A, G2, C, G; G2 -> B**), you have to enter the primary rated current at address 238 **I_{gnd2}-CT PRIM.** and at address 239 **I_{gnd2}-CT SEC.** the secondary rated current of the second ground current transformer connected to I_{N2}.

For proper calculation of phase current I_B , the primary rated current of the ground current transformer, which is used for the calculation of I_B (address 217 or address 238), must be lower than the primary rated current of the phase current transformer (address 204).

Nominal Values of Voltage Transformers (VTs)

At addresses 202 **Vnom PRIMARY** and 203 **Vnom SECONDARY**, information is entered regarding the primary nominal voltage and secondary nominal voltage (phase-to-phase) of the connected voltage transformers.

Transformation Ratio of Voltage Transformers (VTs)

Address 206 **Vph / Vdelta** informs the device of the adjustment factor between the phase voltage and the displacement voltage. This information is relevant for the processing of ground faults (in grounded systems and ungrounded systems), for the operational measured value V_N and measured-variable monitoring.

If the voltage transformer set provides open delta windings and if these windings are connected to the device, this must be specified accordingly in address 213 (see above margin heading "Voltage Connection"). Since the voltage transformer ratio is normally as follows:

$$\frac{V_{\text{nomPrimary}}}{\sqrt{3}} / \frac{V_{\text{nomSecondary}}}{\sqrt{3}} / \frac{V_{\text{nomSecondary}}}{3}$$

the factor V_{ph}/V_N (secondary voltage, address 206 **Vph / Vdelta**) must be set to $3/\sqrt{3} = \sqrt{3} = 1.73$ which must be used if the V_N voltage is connected. For other transformation ratios, i.e. the formation of the displacement voltage via an interconnected transformer set, the factor must be corrected accordingly. For CEI 0-16 standard (ordering data position 14= G), parameter 206 is preset to 3.00.

Please take into consideration that also the calculated secondary V_0 -voltage is divided by the value set in address 206. Thus, even if the V_0 -voltage is not connected, address 206 has an impact on the secondary operational measured value V_N .

If **Vab, Vbc, VGnd** is selected as voltage connection type, parameter **Vph / Vdelta** is used to calculate the phase-to-ground voltages and is therefore important for the protection function. With voltage connection type **Van, Vbn, Vcn**, this parameter is used only to calculate the operational measured value of the „secondary voltage V_N “.

Trip and Close Command Duration (Breaker)

In address 210 the minimum trip command duration **TMin TRIP CMD** is set. This setting applies to all protection functions that can initiate tripping.

In address 211 the maximum close command duration **TMax CLOSE CMD** is set. It applies to the integrated reclosing function. It must be set long enough to ensure that the circuit breaker has securely closed. An excessive duration causes no problem since the closing command is interrupted in the event another trip is initiated by a protection function.

Current Flow Monitoring (Breaker)

Address 212 **BkrClosed I MIN** corresponds to the threshold value of the integrated current flow monitoring system. This parameter is used by several protection functions (e.g. voltage protection with current criterion, overload protection and circuit-breaker maintenance). If the set threshold current is exceeded, the circuit breaker is considered closed and the power system is considered to be in operation.

The threshold value setting applies to all three phases, and must take into consideration all protection functions which are actually used.

The pickup threshold for the circuit-breaker failure protection is set separately (see 2.17.2).

Circuit-breaker Maintenance (Breaker)

Parameters 260 to 267 are assigned to CB maintenance. The parameters and the different procedures are explained in the setting notes of this function (see Section 2.23.2).

Pickup Thresholds of the Binary Inputs (Thresholds BI)

At address 220 **Threshold BI 1** to 226 **Threshold BI 7** you can set the pickup thresholds of the binary inputs of the device. The settings **Thresh. BI 176V**, **Thresh. BI 88V** or **Thresh. BI 19V** are possible.

Two-phase Time Overcurrent Protection (Protection Operating Quantities)

The two-phase time overcurrent protection functionality is used in isolated or resonant-grounded systems where interaction of three-phase devices with existing two-phase protection equipment is required. Via parameter 250 **50/51 2-ph prot** the time overcurrent protection can be configured to two or three-phase operation. If the parameter is set to **ON**, the value 0 A instead of the measured value for I_B is used permanently for the threshold comparison so that no pickup is possible in phase B. All other functions, however, operate in three-phase mode.

Ground Fault (Protection Operating Quantities)

Parameter 613 **Gnd 0/Cprot. w.** lets you specify whether the directional and the non-directional ground fault protection, the breaker failure protection or the fuse failure monitor will use the measured values **I_{gnd} (measured)** or the values **3I0 (calcul.)** calculated from the three phase currents. In the first case, the measured quantity at the fourth current input is evaluated. In the latter case, the summation current is calculated from the three phase current inputs. If the device features a sensitive ground current input (measuring range starts at 1 mA), the ground fault protection always uses the calculated variable 3I0. In this case, parameter 613 **Gnd 0/Cprot. w.** is not available.

Voltage Protection (Protection Operating Quantities)

In a three-phase connection, the fundamental harmonic of the largest of the three phase-to-phase voltages (**V_{phph}**) or phase-Ground voltages (**V_{ph-n}**) or the positive sequence voltage (**V1**) or the negative sequence voltage (**V2**) is supplied to the overvoltage protection elements. In three-phase connection, undervoltage protection relies either on the positive sequence voltage (**V1**) or the smallest of the phase-to-phase voltages (**V_{phph}**) or the phase-to-Ground voltages (**V_{ph-n}**). This is configured by setting the parameter value in address 614 **OP. QUANTITY 59** and 615 **OP. QUANTITY 27**. With single-phase voltage transformers, a direct comparison of the measured quantities with the threshold values is carried out and the parameterization of the characteristic quantity switchover is ignored.



Note

If parameter 213 **VT Connect. 3ph** is set to **V_{ph-g}, VSyn**, the voltage measured by voltage transformer 1 is always used for voltage protection. Then parameters 614 and 615 are not available.



Note

If parameter 213 **VT Connect. 3ph** is set to **V_{ab}, V_{bc}, VSyn** or **V_{ab}, V_{bc}** or **V_{ab}, V_{bc}, V_x**, the setting option **V_{ph-n}** for parameter 614 and 615 is not available.



Note

For CEI 0-16 standard (ordering data position 14=G), the over/under voltage functions only measure the three phase-to-phase voltages, parameter 614 and 615 only have one setting option **Vphph**.

2.1.3.3 Settings

Addresses which have an appended "A" can only be changed with DIGSI, under "Display Additional Settings".

The table indicates region-specific default settings. Column C (configuration) indicates the corresponding secondary nominal current of the current transformer.

Addr.	Parameter	C	Setting Options	Default Setting	Comments
201	CT Starpoint		towards Line towards Busbar	towards Line	CT Starpoint
202	Vnom PRIMARY		0.10 .. 800.00 kV	20.00 kV	Rated Primary Voltage
203	Vnom SECONDARY		34 .. 225 V	100 V	Rated Secondary Voltage (L-L)
204	CT PRIMARY		10 .. 50000 A	400 A	CT Rated Primary Current
205	CT SECONDARY		1A 5A	1A	CT Rated Secondary Current
206A	Vph / Vdelta		1.00 .. 3.00	1.73	Matching ratio Phase-VT To Open-Delta-VT
206A	Vph / Vdelta		1.00 .. 3.00	3.00	Matching ratio Phase-VT To Open-Delta-VT (For CEI 0-16)
209	PHASE SEQ.		A B C A C B	A B C	Phase Sequence
210A	TMin TRIP CMD		0.01 .. 32.00 sec	0.15 sec	Minimum TRIP Command Duration
211A	TMax CLOSE CMD		0.01 .. 32.00 sec	1.00 sec	Maximum Close Command Duration
212	BkrClosed I MIN	1A	0.04 .. 1.00 A	0.04 A	Closed Breaker Min. Current Threshold
		5A	0.20 .. 5.00 A	0.20 A	
213	VT Connect. 3ph		Van, Vbn, Vcn Vab, Vbc, VGnd Vab, Vbc, VSyn Vab, Vbc Vph-g, VSyn Vab, Vbc, Vx	Van, Vbn, Vcn	VT Connection, three-phase
213	VT Connect. 3ph		Vab, Vbc, VGnd	Vab, Vbc, VGnd	VT Connection, three-phase (For CEI 0-16)
214	Rated Frequency		50 Hz 60 Hz	50 Hz	Rated Frequency
215	Distance Unit		km Miles	km	Distance measurement unit

Addr.	Parameter	C	Setting Options	Default Setting	Comments
217	Ignd-CT PRIM		1 .. 50000 A	60 A	Ignd-CT rated primary current
218	Ignd-CT SEC		1A 5A	1A	Ignd-CT rated secondary current
220	Threshold BI 1		Thresh. BI 176V Thresh. BI 88V Thresh. BI 19V	Thresh. BI 176V	Threshold for Binary Input 1
221	Threshold BI 2		Thresh. BI 176V Thresh. BI 88V Thresh. BI 19V	Thresh. BI 176V	Threshold for Binary Input 2
222	Threshold BI 3		Thresh. BI 176V Thresh. BI 88V Thresh. BI 19V	Thresh. BI 176V	Threshold for Binary Input 3
223	Threshold BI 4		Thresh. BI 176V Thresh. BI 88V Thresh. BI 19V	Thresh. BI 176V	Threshold for Binary Input 4
224	Threshold BI 5		Thresh. BI 176V Thresh. BI 88V Thresh. BI 19V	Thresh. BI 176V	Threshold for Binary Input 5
225	Threshold BI 6		Thresh. BI 176V Thresh. BI 88V Thresh. BI 19V	Thresh. BI 176V	Threshold for Binary Input 6
226	Threshold BI 7		Thresh. BI 176V Thresh. BI 88V Thresh. BI 19V	Thresh. BI 176V	Threshold for Binary Input 7
227	Threshold BI 8		Thresh. BI 176V Thresh. BI 88V Thresh. BI 19V	Thresh. BI 176V	Threshold for Binary Input 8
228	Threshold BI 9		Thresh. BI 176V Thresh. BI 88V Thresh. BI 19V	Thresh. BI 176V	Threshold for Binary Input 9
229	Threshold BI 10		Thresh. BI 176V Thresh. BI 88V Thresh. BI 19V	Thresh. BI 176V	Threshold for Binary Input 10
230	Threshold BI 11		Thresh. BI 176V Thresh. BI 88V Thresh. BI 19V	Thresh. BI 176V	Threshold for Binary Input 11
232	VXnom PRIMARY		0.10 .. 800.00 kV	20.00 kV	Rated Primary Voltage X
233	VXnom SECONDARY		100 .. 225 V	100 V	Rated Secondary Voltage X
235A	ATEX100		NO YES	YES	Storage of th. Replicas w/o Power Supply
238	Ignd2-CT PRIM.		1 .. 50000 A	400 A	Ignd2-CT rated primary c. (conn. to I2)
239	Ignd2-CT SEC.		1A 5A	1A	Ignd2-CT rated secondary current (I2)
241	Volt.trans.A:C1		1.0 .. 100.0 pF	10.0 pF	Voltage transducer A: Capacity C1

Addr.	Parameter	C	Setting Options	Default Setting	Comments
242	Volt.trans.A:C2		250 .. 10000 pF	2200 pF	Voltage transducer A: Capacity C2
243	Volt.trans.B:C1		1.0 .. 100.0 pF	10.0 pF	Voltage transducer B: Capacity C1
244	Volt.trans.B:C2		250 .. 10000 pF	2200 pF	Voltage transducer B: Capacity C2
245	Volt.trans.C:C1		1.0 .. 100.0 pF	10.0 pF	Voltage transducer C: Capacity C1
246	Volt.trans.C:C2		250 .. 10000 pF	2200 pF	Voltage transducer C: Capacity C2
250A	50/51 2-ph prot		OFF ON	OFF	50, 51 Time Overcurrent with 2ph. prot.
251A	CT Connect.		A, B, C, (Gnd) A,G2,C,G; G->B A,G2,C,G; G2->B	A, B, C, (Gnd)	CT Connection
252	Ph LPCT pol.		not reversed reversed	not reversed	Phase LPCT orientation / polarity
260	Ir-52		10 .. 50000 A	125 A	Rated Normal Current (52 Breaker)
261	OP.CYCLES AT Ir		100 .. 1000000	10000	Switching Cycles at Rated Normal Current
262	Isc-52		10 .. 100000 A	25000 A	Rated Short-Circuit Breaking Current
263	OP.CYCLES Isc		1 .. 1000	50	Switch. Cycles at Rated Short-Cir. Curr.
264	Ix EXPONENT		1.0 .. 3.0	2.0	Exponent for the Ix-Method
265	Cmd.via control		(Setting options depend on configuration)	None	52 B.Wear: Open Cmd. via Control Device
266	T 52 BREAKTIME		1 .. 600 ms	80 ms	Breaktime (52 Breaker)
267	T 52 OPENING		1 .. 500 ms	65 ms	Opening Time (52 Breaker)
280	Holmgr. for Σi		NO YES	NO	Holmgreen-conn. (for fast sum-i-monit.)
310	Iph-PRIM ref.		10 .. 50000 A	400 A	Primary refer. phase current for prot.
311	Iph-LPCT PRIM		1 .. 5000 A	400 A	Rated primary phase current LPCT
312	Ignd-PRIM ref.		1 .. 50000 A	60 A	Primary refer. ground current for prot.
313	Ignd-LPCT PRIM		0.01 .. 5000.00 A	2.00 A	Rated primary ground current LPCT
314	Vph-LPCT SEC		10.0 .. 1000.0 mV	225.0 mV	Rated secondary phase voltage LPCT
315	Vgnd-LPCT SEC		10.0 .. 1000.0 mV	225.0 mV	Rated secondary ground voltage LPCT

Addr.	Parameter	C	Setting Options	Default Setting	Comments
320A	Corr.factor IL1		0.9000 .. 1.1000	1.0000	Correction factor for magnitude IL1
321A	Corr.factor IL2		0.9000 .. 1.1000	1.0000	Correction factor for magnitude IL2
322A	Corr.factor IL3		0.9000 .. 1.1000	1.0000	Correction factor for magnitude IL3
323A	Corr.factor IE		0.9000 .. 1.1000	1.0000	Correction factor for magnitude IE
324A	Corr.factor IEE		0.9000 .. 1.1000	1.0000	Correction factor for magnitude IEE
330	V-LPVT SEC		3.00 .. 17.00 V	3.25 V	rated secondary voltage LPVT
332A	V-LPVT PHA		-10.00 .. 10.00 °	0.00 °	phase angle LPVT
613A	Gnd O/Cprot. w.		I _{gnd} (measured) 3I ₀ (calcul.)	I _{gnd} (measured)	Ground Overcurrent protection with
614A	OP. QUANTITY 59		V _{phph} V _{ph-n} V1 V2	V _{phph}	Opera. Quantity for 59 Overvolt. Prot.
614A	OP. QUANTITY 59		V _{phph}	V _{phph}	Opera. Quantity for 59 Overvolt. Prot. (For CEI 0-16)
615A	OP. QUANTITY 27		V1 V _{phph} V _{ph-n}	V1	Opera. Quantity for 27 Undervolt. Prot.
615A	OP. QUANTITY 27		V _{phph}	V _{phph}	Opera. Quantity for 27 Undervolt. Prot. (For CEI 0-16)
616	STATIC GEN.		YES NO	NO	Static or non self-exc. Asyn. Generator (For CEI 0-16)

2.1.3.4 Information List

No.	Information	Type of Information	Comments
5145	>Reverse Rot.	SP	>Reverse Phase Rotation
5147	Rotation ABC	OUT	Phase rotation ABC
5148	Rotation ACB	OUT	Phase rotation ACB
10036	Capac.Par.Fail.	OUT	Malparameteriz. Volt.-divider Capacities

2.1.4 Oscillographic Fault Records

The Multifunctional Protection with Control 7SJ80 is equipped with a fault record memory. The instantaneous values of the measured values

$i_A, i_B, i_C, i_N, i_{Ns}$ and $V_A, V_B, V_C, V_{AB}, V_{BC}, V_{CA}, V_N, V_X, V_{ph-n}, V_{SYN}$

(voltages depending on connection) are sampled at intervals of 1.0 ms (at 50 Hz) and stored in a revolving buffer (20 samples per cycle). In the event of a fault, the data are recorded for a set period of time, but not for more than 5 seconds. A minimum of 8 faults can be recorded in this buffer. The fault record memory is automatically updated with every new fault, so no acknowledgment for previously recorded faults is required. In addition to protection pickup, the recording of the fault data can also be started via a binary input or via the serial interface.

2.1.4.1 Description

The data of a fault event can be read out via the device interface and evaluated with the help of the SIGRA 4 graphic analysis software. SIGRA 4 graphically represents the data recorded during the fault event and also calculates additional information from the measured values. Currents and voltages can be presented either as primary or as secondary values. Signals are additionally recorded as binary tracks (marks), e.g. "pickup", "trip".

If port B of the device has been configured correspondingly, the fault record data can be imported by a central controller via this interface and evaluated. Currents and voltages are prepared for a graphic representation. Signals are additionally recorded as binary tracks (marks), e.g. "pickup", "trip".

The retrieval of the fault data by the central controller takes place automatically either after each protection pickup or after a tripping.

If device parameter 651 **ParEN100(LC)b1k** is set to **ON**, you can also read out fault records via port A (see Section 2.1.2.2).

Depending on the selected type of connection of the voltage transformers (address 213 **VT Connect. 3ph**), the following measured values are recorded in the fault record:

	Voltage connection					
	Van, Vbn, Vcn	Vab, Vbc, VGnd	Vab, Vbc	Vab, Vbc, Vx	Vab, Vbc, VSyn	Vph-g, VSyn
V _{AB}	yes	yes	yes	yes	yes	
V _{BC}	yes	yes	yes	yes	yes	
V _{CA}	yes	yes	yes	yes	yes	
V _A	yes	yes				
V _B	yes	yes				
V _C	yes	yes				
V						yes
V ₀	yes	yes				
V _{SYN}					yes	yes
V _x				yes		



Note

The signals used for the binary tracks can be allocated in DIGSI.



Note

If one of the current transformer connection types **A, G2, C, G; G->B** or **A, G2, C, G; G2->B** has been selected via parameter 251 **CT Connect.**, the ground current I_{N2} measured with the second current transformer is indicated under track I_N . The ground current detected by the fourth current transformer is indicated under track I_{Ns} .

2.1.4.2 Setting Notes

Specifications

Fault recording (waveform capture) will only take place if address 104 **OSC. FAULT REC.** is set to **Enabled**. Other settings pertaining to fault recording (waveform capture) are found in the OSC. FAULT REC. submenu of the SETTINGS menu. Waveform capture makes a distinction between the trigger instant for an oscillographic record and the criterion to save the record (address 401 **WAVEFORMTRIGGER**). Normally, the trigger is the pickup of a protection element, i.e. the time 0 is defined as the instant the first protection function picks up. The criterion for saving may be both the device pickup (**Save w. Pickup**) or the device trip (**Save w. TRIP**). A trip command issued by the device can also be used as trigger instant (**Start w. TRIP**), in this case it is also the saving criterion.

A fault event starts with the pickup by any protection function and ends when the last pickup of a protection function has dropped out. Usually this is also the extent of a fault recording (address 402 **WAVEFORM DATA = Fault event**). If automatic reclosing is performed, the entire system fault — with several reclosing attempts if necessary — can be recorded until the fault has been cleared for good (address 402 **WAVEFORM DATA = Pow.Sys.Flt.**). This facilitates the representation of the entire system fault history, but also consumes storage capacity during the automatic reclosing dead time(s).

The actual storage time begins at the pre-fault time **PRE. TRIG. TIME** (address 404) ahead of the reference instant, and ends at the post-fault time **POST REC. TIME** (address 405) after the storage criterion has reset. The maximum storage duration of each fault record (**MAX. LENGTH**) is entered at address 403. Recording per fault must not exceed 5 seconds. At least 8 records can be saved altogether with a maximum total time of 18 s.

An oscillographic record can be triggered by a status change of a binary input, or from a PC via the operator interface. Storage is then triggered dynamically. The length of the fault recording is set in address 406 **BinIn CAPT. TIME** (but not longer than **MAX. LENGTH**, address 403). Pre-fault and post-fault times will add to this. If the binary input time is set to ∞ , the length of the record equals the time that the binary input is activated (static), but not longer than the **MAX. LENGTH** (address 403).

2.1.4.3 Settings

Addr.	Parameter	Setting Options	Default Setting	Comments
401	WAVEFORMTRIGGER	Save w. Pickup Save w. TRIP Start w. TRIP	Save w. Pickup	Waveform Capture
402	WAVEFORM DATA	Fault event Pow.Sys.Flt.	Fault event	Scope of Waveform Data
403	MAX. LENGTH	0.30 .. 5.00 sec	2.00 sec	Max. length of a Waveform Capture Record
404	PRE. TRIG. TIME	0.05 .. 0.50 sec	0.25 sec	Captured Waveform Prior to Trigger
405	POST REC. TIME	0.05 .. 0.50 sec	0.10 sec	Captured Waveform after Event
406	BinIn CAPT.TIME	0.10 .. 5.00 sec; ∞	0.50 sec	Capture Time via Binary Input

2.1.4.4 Information List

No.	Information	Type of Information	Comments
-	FltRecSta	IntSP	Fault Recording Start
4	>Trig.Wave.Cap.	SP	>Trigger Waveform Capture
203	Wave. deleted	OUT_Ev	Waveform data deleted
30053	Fault rec. run.	OUT	Fault recording is running

2.1.5 Settings Groups

Up to four different setting groups can be created for establishing the device's function settings.

2.1.5.1 Description

Changing Setting Groups

During operation the user can switch back and forth setting groups locally, via the operator panel, binary inputs (if so configured), the service interface using a personal computer, or via the system interface. For reasons of safety it is not possible to change between setting groups during a power system fault.

A setting group includes the setting values for all functions that have been selected as **Enabled** during configuration (see Section 2.1.1.2). In 7SJ80 relays, four independent setting groups (A to D) are available. While setting values may vary, the selected functions of each setting group remain the same.

2.1.5.2 Setting Notes

General

If you do not need the setting group change option, use the default group A. The rest of this paragraph is then not relevant.

If the changeover option is desired, group changeover must be set to **Grp Chge OPTION = Enabled** (address 103) when the function extent is configured. For the setting of the function parameters, each of the required setting groups A to D (a maximum of 4) must be configured in sequence. The SIPROTEC 4 System Description gives further information on how to copy setting groups or reset them to their status at delivery and also how to change from one setting group to another.

Subsection 3.1 of this manual tells you how to change between several setting groups externally via binary inputs.

2.1.5.3 Settings

Addr.	Parameter	Setting Options	Default Setting	Comments
302	CHANGE	Group A Group B Group C Group D Binary Input Protocol	Group A	Change to Another Setting Group

2.1.5.4 Information List

No.	Information	Type of Information	Comments
-	P-GrpA act	IntSP	Setting Group A is active
-	P-GrpB act	IntSP	Setting Group B is active
-	P-GrpC act	IntSP	Setting Group C is active
-	P-GrpD act	IntSP	Setting Group D is active
7	>Set Group Bit0	SP	>Setting Group Select Bit 0
8	>Set Group Bit1	SP	>Setting Group Select Bit 1

2.1.6 Power System Data 2

Applications

- If the primary reference voltage and the primary reference current of the protected object are set, the device is able to calculate and output the percentaged operational measured values.

2.1.6.1 Description

The general protection data (**P.System Data 2**) includes parameters common to all functions, i.e. not associated with a specific protection or monitoring function. In contrast to the **P.System Data 1** as discussed before, they can be changed with the parameter group.

2.1.6.2 Setting Notes

Rated Values of the System

At addresses 1101 **FullScaleVolt** and 1102 **FullScaleCurr** the primary reference voltage (phase-to-phase) and the reference current (phases) of the protected equipment is entered. If these reference values match the primary nominal values of the VTs and CTs, they correspond to the settings in address 202 and 204 (Section 2.1.3.2). They are generally used to show values referenced to full scale.

Ground Impedance Ratios (only for Fault Location)

The adjustment of the ground impedance ratio is only important for the utilization of the line fault location function. This is done by entering the resistance ratio **RE/RL** and the reactance ratio **XE/XL**.

The values under addresses 1103 and 1104 apply if only one line section is available and to all faults that occur outside the defined line sections.

If several line sections are set, the following shall apply:

- for line section 1, addresses 6001 and 6002
- for line section 2, addresses 6011 and 6012
- for line section 3, the addresses 6021 and 6022.

Resistance ratio **RE/RL** and reactance ratio **XE/XL** are calculated formally and do not correspond to the real and imaginary components of Z_F/Z_L . No complex calculation is required! The ratios can be obtained from the line data using the following formulas:

$$\frac{R_G}{R_L} = \frac{1}{3} \cdot \left(\frac{R_0}{R_1} - 1 \right) \qquad \frac{X_G}{X_L} = \frac{1}{3} \cdot \left(\frac{X_0}{X_1} - 1 \right)$$

Where

R_0	– Zero sequence resistance of the line
X_0	– Zero sequence reactance of the line
R_1	– Positive sequence resistance of the line
X_1	– Positive sequence reactance of the line

This data can be used for the entire line or line section, or as distance-related values, since the quotients are independent of the distance.

Calculation example:

20 kV free line 120 mm² with the following data:

$R_0/s = 0.88 \Omega/\text{km}$ (1.42 Ω/mile) Zero sequence resistance

$X_0/s = 1.26 \Omega/\text{km}$ (2.03 Ω/mile) Zero sequence reactance

$R_1/s = 0.24 \Omega/\text{km}$ (0.39 Ω/mile) Positive sequence resistance

$X_1/s = 0.34 \Omega/\text{km}$ (0.55 Ω/mile) Positive sequence reactance

For ground impedance ratios, the following results:

$$\frac{R_G}{R_L} = \frac{1}{3} \cdot \left(\frac{R_0}{R_1} - 1 \right) = \frac{1}{3} \cdot \left(\frac{1.42 \Omega/\text{mile}}{0.39 \Omega/\text{mile}} - 1 \right) = 0.89$$

$$\frac{X_G}{X_L} = \frac{1}{3} \cdot \left(\frac{X_0}{X_1} - 1 \right) = \frac{1}{3} \cdot \left(\frac{2.03 \Omega/\text{mile}}{0.55 \Omega/\text{mile}} - 1 \right) = 0.90$$

Reactance per Unit Length (only for Fault Location)

The setting of the reactance per unit length is only important for the utilization of the line fault location function. The reactance setting enables the protective relay to indicate the fault location in terms of distance.

The reactance value X' is entered as a reference value x' , i.e. in Ω/mile if set to distance unit **Miles** (address 215, see Section 2.1.3.2 under "Distance Unit") or in Ω/km if set to distance unit **km**. If, after having entered the reactance per unit length, the distance unit is changed under address 215, the reactance per unit length must be reconfigured in accordance with the new distance unit.

The values under address 1106 (**km**) or 1105 (**Miles**) apply if only one line section is available and to all faults that occur outside the defined line sections.

If several line sections are set, the following shall apply:

- for line section 1, addresses 6004(**km**) or 6003 (**Miles**)
- for line section 2, addresses 6014(**km**) or 6013 (**Miles**)
- for line section 3, addresses 6024 (**km**) or 6023 (**Miles**).

When setting the parameters in DIGSI, the values can also be entered as primary values. In that case the following conversion to secondary values is not required.

For the conversion of primary values to secondary values the following applies in general:

$$Z_{\text{secondary}} = \frac{\text{Current-Transformer-Ratio}}{\text{Voltage-Transformer - Ratio}} \cdot Z_{\text{primary}}$$

Likewise, the following applies to the reactance per unit length of a line:

$$X'_{\text{sec}} = \frac{N_{\text{CTR}}}{N_{\text{VTR}}} \cdot X'_{\text{prim}}$$

with

N_{CTR} — Transformation ratio of the current transformer

N_{VTR} — Transformation ratio of the voltage transformer

Calculation example:

In the following, the same line as illustrated in the example for ground impedance ratios (above) and additional data on the voltage transformers will be used:

Current Transformers 500 A/5 A

Voltage Transformers 20 kV/0.1 kV

The secondary reactance per unit length is calculated as follows:

$$X'_{\text{sec}} = \frac{N_{\text{CTR}}}{N_{\text{VTR}}} \cdot X'_{\text{prim}} = \frac{500 \text{ A}/5 \text{ A}}{20 \text{ kV}/0.1 \text{ kV}} \cdot 0.55 \text{ } \Omega/\text{mile} = 0.275 \text{ } \Omega/\text{mile}$$

Line Angle (only for Fault Location)

The setting of the line angle is only important for the utilization of the line fault location function. The line angle can be derived from the line constants. The following applies:

$$\tan \varphi = \frac{X_L}{R_L} \quad \text{or} \quad \varphi = \arctan\left(\frac{X_L}{R_L}\right)$$

with R_L being the ohmic resistance and X_L being the reactance of the line.

The value under address 1109 applies if only one line section is available and to all faults that occur outside the defined line sections.

If several line sections are set, the following shall apply:

- for line section 1, address 6005
- for line section 2, address 6015
- for line section 3, address 6025

This data can be used for the entire line or line section, or as distance-related values, since the quotients are independent of the distance. It is also irrelevant whether the quotients were derived from primary or secondary values.

Calculation Example:

110 kV free line 150 mm² with the following data:

$$R'_1 = 0.31 \Omega/\text{mile}$$

$$X'_1 = 0.69 \Omega/\text{mile}$$

The line angle is calculated as follows:

$$\tan \varphi = \frac{X_L}{R_L} = \frac{X'_1}{R'_1} = \frac{0.69 \Omega/\text{mile}}{0.31 \Omega/\text{mile}} = 2.21 \quad \varphi = 65.7^\circ$$

The respective address must be set to **Line angle = 66°**.

Line Length (only for Fault Location)

The setting of the line length is only important for the utilization of the line fault location function. The line length is required so that the fault location can be given as a reference value (in %). Furthermore, when using several line sections, the respective length of the individual sections is defined.

The values under address 1110 (*km*) or 1111 (*Miles*) apply if only one line section is available and to all faults that occur outside the defined line sections.

If several line sections are set, the following shall apply:

- for line section 1, addresses 6007 (*km*) or 6006 (*Miles*)
- for line section 2, addresses 6017 (*km*) or 6016 (*Miles*)
- for line section 3, addresses 6027 (*km*) or 6026 (*Miles*)

The length set for the entire line must correspond to the sum of lengths configured for the line sections. A deviation of 10% max. is admissible.

Operating Range of the Overload Protection

The current threshold entered in address 1107 **I MOTOR START** limits the operating range of the overload protection to larger current values. The thermal replica is kept constant for as long as this threshold is exceeded.

Inverting Power Measured Values/Metered Values

The directional values (power, power factor, work and related min., max., mean and setpoint values), calculated in the operational measured values, are usually defined a positive in the direction of the protected object. This requires that the connection polarity for the entire device was configured accordingly in the **P.System Data 1** (compare also "Polarity of the Current Transformers", address 201). But it is also possible to make different settings for the "forward" direction" for the protection functions and the positive direction for the power etc., e.g. to have the active power supply (from the line to the busbar) displayed positively. To do so, set address 1108 **P,Q sign to reversed**. If the setting is **not reversed** (default), the positive direction for the power etc. corresponds to the "forward" direction for the protection functions. Section 4 provides a detailed list of the values in question.

2.1.6.3 Special Feature In CEI 0-16 Standard

Inverted PI functions trip signal

In CEI 0-16 standard, while a network fault occurs, DDI is tripped by the so called PI functions (27, 59, 59V0, 81, direct trip) through a positive logic output relay, a NO binary output (18424 "PI Trip NC") which is energized when the protection device is OK and not in trip condition:

- The contact opens for PI protection trip (include 27, 59, 59V0, 81, direct trip) or in case of loss of power supply.
- When the device powers on, at the end of the boot operations, before energizing the trip binary output, a check of absence of pick-up conditions is carried out. If there is a pickup condition of PI functions then the 7SJ80 does not close the tripping contact as long as the pick up situation is present.

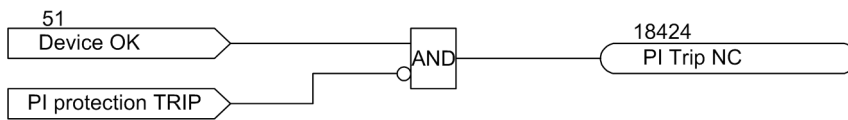

Figure 2-6 Logic diagram of PI Trip NC

Direct Trip

In the CEI 0-16 standard the tripping command can be issued by a communication command (466.4010 "Cmd Trip") from the system interface or via GOOSE message (18421 "Trip via GOOSE") using IEC61850 protocol.

Tripping via binary input (18420 ">Trip via BI") is also possible.

Each source is independent from the others which means that if a remote trip from protocol is configured it is additionally possible to configure a trip via BI.

All the direct trip elements can be blocked via ">DDI Open". The ">DDI open" signal must be connected only in the cases specified at chapter 2.6.2.1.

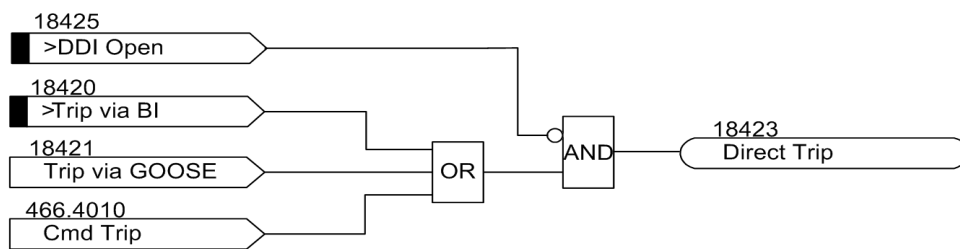

Figure 2-7 Logic diagram of PI Direct Trip

2.1.6.4 Settings

The table indicates region-specific default settings. Column C (configuration) indicates the corresponding secondary nominal current of the current transformer.

Addr.	Parameter	C	Setting Options	Default Setting	Comments
1101	FullScaleVolt.		0.10 .. 800.00 kV	20.00 kV	Measur:FullScaleVoltage(Equipm.rating)
1102	FullScaleCurr.		10 .. 50000 A	400 A	Measur:FullScaleCurrent(Equipm.rating)
1103	RE/RL		-0.33 .. 7.00	1.00	Zero seq. compensating factor RE/RL
1104	XE/XL		-0.33 .. 7.00	1.00	Zero seq. compensating factor XE/XL
1105	x'	1A	0.0050 .. 15.0000 Ω/mi	0.2420 Ω/mi	feeder reactance per mile: x'
		5A	0.0010 .. 3.0000 Ω/mi	0.0484 Ω/mi	
1106	x'	1A	0.0050 .. 9.5000 Ω/km	0.1500 Ω/km	feeder reactance per km: x'
		5A	0.0010 .. 1.9000 Ω/km	0.0300 Ω/km	
1107	I MOTOR START	1A	0.40 .. 10.00 A	2.50 A	Motor Start Current (Block 49, Start 48)
		5A	2.00 .. 50.00 A	12.50 A	
1108	P,Q sign		not reversed reversed	not reversed	P,Q operational measured values sign
1109	Line angle		10 .. 89 °	85 °	Line angle
1110	Line length		0.1 .. 1000.0 km	100.0 km	Line length in kilometer
1111	Line length		0.1 .. 650.0 Miles	62.1 Miles	Line length in miles
6001	S1: RE/RL		-0.33 .. 7.00	1.00	S1: Zero seq. compensating factor RE/RL
6002	S1: XE/XL		-0.33 .. 7.00	1.00	S1: Zero seq. compensating factor XE/XL
6003	S1: x'	1A	0.0050 .. 15.0000 Ω/mi	0.2420 Ω/mi	S1: feeder reactance per mile: x'
		5A	0.0010 .. 3.0000 Ω/mi	0.0484 Ω/mi	
6004	S1: x'	1A	0.0050 .. 9.5000 Ω/km	0.1500 Ω/km	S1: feeder reactance per km: x'
		5A	0.0010 .. 1.9000 Ω/km	0.0300 Ω/km	
6005	S1: Line angle		10 .. 89 °	85 °	S1: Line angle
6006	S1: Line length		0.1 .. 650.0 Miles	62.1 Miles	S1: Line length in miles
6007	S1: Line length		0.1 .. 1000.0 km	100.0 km	S1: Line length in kilometer
6011	S2: RE/RL		-0.33 .. 7.00	1.00	S2: Zero seq. compensating factor RE/RL
6012	S2: XE/XL		-0.33 .. 7.00	1.00	S2: Zero seq. compensating factor XE/XL
6013	S2: x'	1A	0.0050 .. 15.0000 Ω/mi	0.2420 Ω/mi	S2: feeder reactance per mile: x'
		5A	0.0010 .. 3.0000 Ω/mi	0.0484 Ω/mi	

Addr.	Parameter	C	Setting Options	Default Setting	Comments
6014	S2: x'	1A	0.0050 .. 9.5000 Ω/km	0.1500 Ω/km	S2: feeder reactance per km: x'
		5A	0.0010 .. 1.9000 Ω/km	0.0300 Ω/km	
6015	S2: Line angle		10 .. 89 °	85 °	S2: Line angle
6016	S2: Line length		0.1 .. 650.0 Miles	62.1 Miles	S2: Line length in miles
6017	S2: Line length		0.1 .. 1000.0 km	100.0 km	S2: Line length in kilometer
6021	S3: RE/RL		-0.33 .. 7.00	1.00	S3: Zero seq. compensating factor RE/RL
6022	S3: XE/XL		-0.33 .. 7.00	1.00	S3: Zero seq. compensating factor XE/XL
6023	S3: x'	1A	0.0050 .. 15.0000 Ω/mi	0.2420 Ω/mi	S3: feeder reactance per mile: x'
		5A	0.0010 .. 3.0000 Ω/mi	0.0484 Ω/mi	
6024	S3: x'	1A	0.0050 .. 9.5000 Ω/km	0.1500 Ω/km	S3: feeder reactance per km: x'
		5A	0.0010 .. 1.9000 Ω/km	0.0300 Ω/km	
6025	S3: Line angle		10 .. 89 °	85 °	S3: Line angle
6026	S3: Line length		0.1 .. 650.0 Miles	62.1 Miles	S3: Line length in miles
6027	S3: Line length		0.1 .. 1000.0 km	100.0 km	S3: Line length in kilometer

2.1.6.5 Information List

No.	Information	Type of Information	Comments
126	ProtON/OFF	IntSP	Protection ON/OFF (via system port)
356	>Manual Close	SP	>Manual close signal
501	Relay PICKUP	OUT	Relay PICKUP
511	Relay TRIP	OUT	Relay GENERAL TRIP command
533	Ia =	VI	Primary fault current Ia
534	Ib =	VI	Primary fault current Ib
535	Ic =	VI	Primary fault current Ic
561	Man.Clos.Detect	OUT	Manual close signal detected
2720	>Enable ANSI#-2	SP	>Enable 50/67-(N)-2 (override 79 blk)
4601	>52-a	SP	>52-a contact (OPEN, if bkr is open)
4602	>52-b	SP	>52-b contact (OPEN, if bkr is closed)
16019	>52 Wear start	SP	>52 Breaker Wear Start Criteria
16020	52 WearSet.fail	OUT	52 Wear blocked by Time Setting Failure
16027	52WL.blk I PErr	OUT	52 Breaker Wear Logic blk Ir-CB=>Isc-CB
16028	52WL.blk n PErr	OUT	52 Breaker W.Log.blk SwCyc.Isc=>SwCyc.Ir
18424	PI Trip NC	OUT	PI Trip NC(ON,if Device ok & No Trip) (For CEI 0-16)
18425	>DDI Open	SP	>DDI Open status (For CEI 0-16)
18423	Direct Trip	OUT	Direct Trip (For CEI 0-16)
18420	>Trip via BI	SP	>Trip via Binary Input (For CEI 0-16)

No.	Information	Type of Information	Comments
18421	Trip via GOOSE	ExSP	Trip via GOOSE (For CEI 0-16)
466.4010 .01	Cmd Trip	IntSP	Trip via control command (For CEI 0-16)

2.1.7 EN100-Module

2.1.7.1 Description

The **EN100-Module** enables integration of the 7SJ80 in 100-Mbit communication networks in control and automation systems with the protocols according to IEC 61850 standard. This standard permits uniform communication of the devices without gateways and protocol converters. Even when installed in heterogeneous environments, SIPROTEC 4 relays therefore provide for open and interoperable operation. Parallel to the process control integration of the device, this interface can also be used for communication with DIGSI and for inter-relay communication via GOOSE.

2.1.7.2 Setting Notes

IEC 61850 GOOSE Function

The GOOSE function can be disabled via a device parameter. For more information, please refer to Section 2.1.2.2.

2.1.7.3 Information List

No.	Information	Type of Information	Comments
009.0100	Failure Modul	IntSP	Failure EN100 Modul
009.0101	Fail Ch1	IntSP	Failure EN100 Link Channel 1 (Ch1)
009.0102	Fail Ch2	IntSP	Failure EN100 Link Channel 2 (Ch2)

2.2 Overcurrent Protection 50, 51, 50N, 51N

The overcurrent protection is provided with a total of four elements each for the phase currents and the ground current. All elements are independent from each other and can be combined as desired.

If it is desired in isolated or resonant-grounded systems that three-phase devices should work together with two-phase protection equipment, the overcurrent protection can be configured in such a way that it allows two-phase operation besides the three-phase mode (see Chapter 2.1.3.2).

The high-set elements 50-2, 50-3, 50N-2, 50N-3 as well as the overcurrent elements 50-1 and 50N-1 always operate with a definite tripping time (51), the elements 51 and 51N always with an inverse tripping time (50).

Applications

- The non-directional overcurrent protection is applicable for networks that are radial and supplied from a single source or open looped networks, for backup protection of differential protective schemes of all types of lines, transformers, generators and busbars.

2.2.1 General

The overcurrent protection for the ground current can either operate with measured values I_N or with the quantities $3I_0$ calculated from the three phase currents. Which values are used depends on the setting of parameter 613 **Gnd O/Cprot. w.** and the selected type of connection of the current transformers. Information on this can be found in Chapter 2.1.3.2, connection examples in the Appendix A.3. Devices featuring a sensitive ground current input, however, generally use the calculated quantity $3I_0$.

All overcurrent Elements enabled in the device may be blocked via the automatic reclosing function (depending on the cycle) or via an external signal to the binary inputs of the device. Removal of blocking during pickup will restart time delays. The Manual Close signal is an exception in this case. If a circuit breaker is manually closed onto a fault, it can be re-opened immediately. For overcurrent Elements or high-set Elements the delay may be bypassed via a Manual Close pulse, thus resulting in high speed tripping. This pulse is extended up to at least 300 ms.

The automatic reclosure function 79 may also initiate immediate tripping for the overcurrent and high-set elements depending on the cycle.

Pickup of the definite-time elements can be stabilized by setting the dropout times. This protection is used in systems where intermittent faults occur. Combined with electromechanical relays, it allows different dropout responses to be adjusted and a time grading of digital and electromechanical relays to be implemented.

Pickup and delay settings may be quickly adapted to system requirements via dynamic setting changeover (see Section 2.4).

Tripping by the 50-1 and 51 elements (in phases), 50N-1 and 51N elements (in ground path) may be blocked for inrush conditions by utilizing the inrush restraint feature.

The following table gives an overview of the interconnections to other functions of the devices 7SJ80.

Table 2-3 Interconnection to other functions

Overcurrent Elements	Connection to Automatic Reclosing	Manual CLOSE	Dynamic Cold Load Pickup	Inrush Restraint
50-1	•	•	•	•
50-2	•	•	•	
50-3	•	•	•	
51	•	•	•	•
50N-1	•	•	•	•
50N-2	•	•	•	
50N-3	•	•	•	
51N	•	•	•	•

2.2.2 Definite Time High-set Elements 50-3, 50-2, 50N-3, 50N-2

For each Element, an individual pickup value **50-3 PICKUP**, **50-2 PICKUP** or **50N-3 PICKUP**, **50N-2 PICKUP** is set. For **50-3 PICKUP** and **50N-3 PICKUP**, it is possible to measure the *Instantaneous* in addition to *Fundamental* and *True RMS*. If set to *Instantaneous*, the element picks up at $2 \cdot \sqrt{2} \cdot \text{setting value}$ (rms). Each phase and ground current is compared separately per Element with the common pickup values **50-3 PICKUP**, **50-2 PICKUP** or **50N-3 PICKUP**, **50N-2 PICKUP**. If the respective pickup value is exceeded, this is signaled. After the user-defined time delays **50-3 DELAY**, **50-2 DELAY** or **50N-3 DELAY**, **50N-2 DELAY** have elapsed, trip commands are issued which are available for each Element. The dropout value is roughly equal to 95% of the pickup value for currents $> 0.3 I_{Nom}$. If the measurement of the instantaneous values has been parameterized for the **50-3 PICKUP** or 50N-3 Element, the dropout ratio is set to 90 %.

Pickup can be stabilized by setting dropout times **1215 50 T DROP-OUT** or **1315 50N T DROP-OUT**. This time is started and maintains the pickup condition if the current falls below the threshold. Therefore, the function does not drop out at high speed. The trip delay time **50-3 DELAY**, **50-2 DELAY** or **50N-3 DELAY**, **50N-2 DELAY** continues running in the meantime. After the dropout delay time has elapsed, the pickup is reported OFF and the trip delay time is reset unless the threshold **50-3 PICKUP**, **50-2 PICKUP** or **50N-3 PICKUP**, **50N-2 PICKUP** has been exceeded again. If the threshold is exceeded again during the dropout delay time, the time is canceled. The trip delay time **50-3 DELAY**, **50-2 DELAY** or **50N-3 DELAY**, **50N-2 DELAY** continues running in the meantime. If the threshold value is exceeded after this time has elapsed, the trip command is issued immediately. If the threshold value is not exceeded at this time, there is no reaction. If the threshold value is exceeded again after expiry of the trip command delay time while the dropout delay time is still running, tripping is initiated immediately.

These elements can be blocked by the automatic reclosing function (79 AR).

The pickup values of each 50-2, 50-3 Element for phase currents and 50N-2, 50N-3 Element for the ground current and the element-specific time delays can be set individually.

The following figures show the logic diagrams for the 50-2 and 50N-2 high-set elements as an example. They also apply analogously to the high-set elements 50-3 and 50N-3.

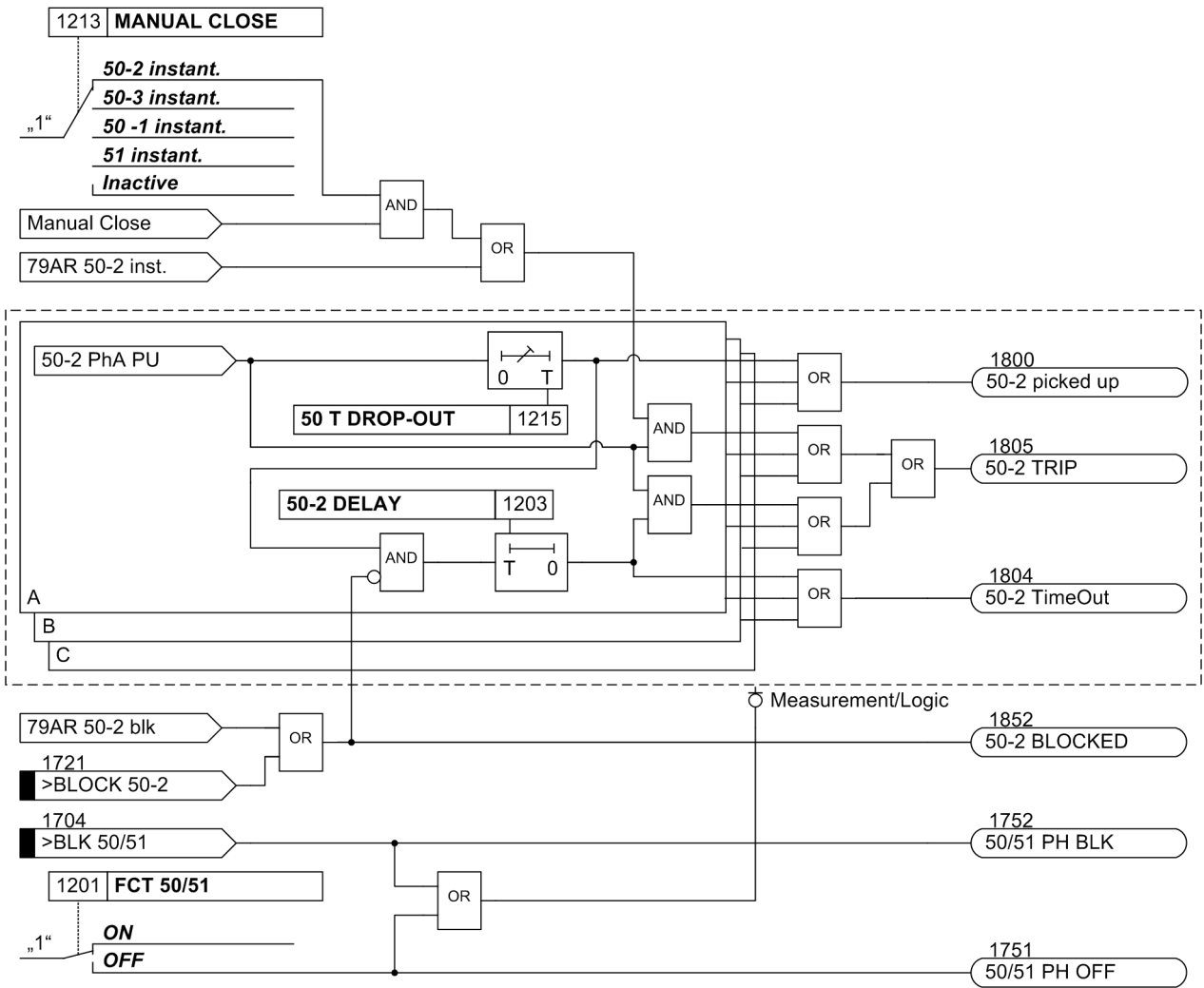

Figure 2-8 Logic diagram for 50-2 high-set element for phases

If parameter 1213 **MANUAL CLOSE** is set to **50-2 instant.** or **50-3 instant.** and manual close detection is used, a pickup causes instantaneous tripping even if the Element is blocked via a binary input.

The same applies to 79 AR 50-2 inst. or 79 AR 50-3 inst.

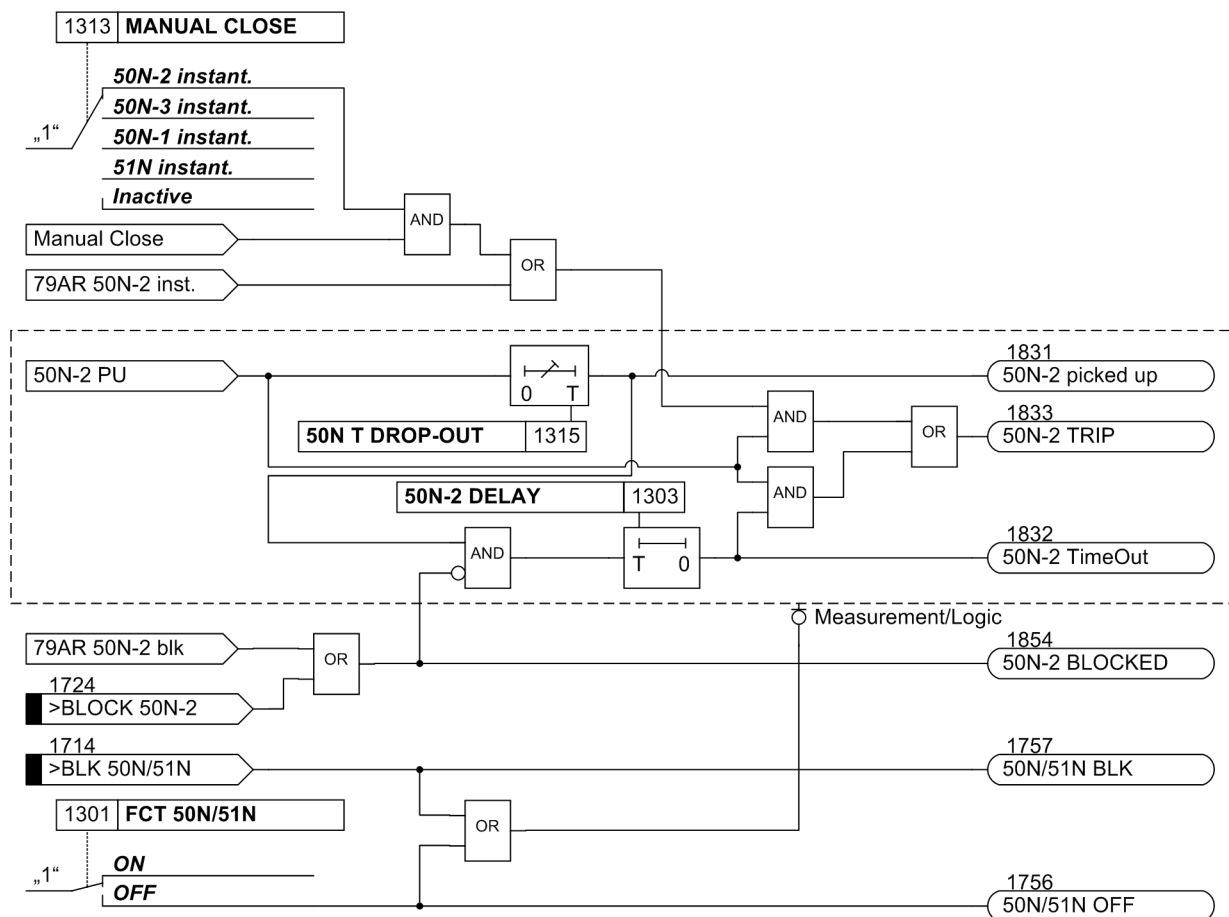

Figure 2-9 Logic diagram for 50N-2 high-set element

If parameter 1313 **MANUAL CLOSE** is set to **50N-2 instant.** or **50N-3 instant.** and manual close detection is used, a pickup causes instantaneous tripping even if the Element is blocked via a binary input.

The same applies to 79 AR 50N-2 inst. or 79 AR 50N-3 inst.

2.2.3 Definite Time Overcurrent Elements 50-1, 50N-1

For each Element an individual pickup value **50-1 PICKUP** or **50N-1 PICKUP** is set. Apart from **Fundamenta1**, the **True RMS** can also be measured. Each phase and ground current is compared separately with the setting value 50-1 or 50N-1 for each Element. If the respective value is exceeded, this is signaled. If the inrush restraint feature (see below) is applied, either the normal pickup signals or the corresponding inrush signals are output as long as inrush current is detected. After user-configured time delays **50-1 DELAY** or **50N-1 DELAY** have elapsed, a trip signal is issued if no inrush current is detected or inrush restraint is disabled. If the inrush restraint feature is enabled and an inrush condition exists, no tripping takes place but a message is recorded and displayed indicating when the overcurrent element time delay elapses. Trip signals and signals on the expiration of time delay are available separately for each Element. The dropout value is approximately 95% of the pickup value for currents $> 0.3 I_{Nom}$.

Pickup can be stabilized by setting dropout times 1215 **50 T DROP-OUT** or 1315 **50N T DROP-OUT**. This time is started and maintains the pickup condition if the current falls below the threshold. Therefore, the function does not drop out at high speed. The trip-command delay time **50-1 DELAY** or **50N-1 DELAY** continues running in the meantime. After the dropout delay time has elapsed, the pickup is reported OFF and the trip delay time is reset unless the threshold 50-1 or 50N-1 has been exceeded again. If the threshold is exceeded again during the dropout delay time, the time is canceled. However, the trip-command delay time **50-1 DELAY** or **50N-1 DELAY** continues running. If the threshold value is exceeded after its expiry, the trip command is issued immediately. If the threshold value is not exceeded at this time, there is no reaction. If the threshold value is exceeded again after expiry of the trip-command delay time, while the dropout delay time is still running, tripping occurs immediately.

Pickup stabilization of the overcurrent elements 50-1 or 50N-1 by means of settable dropout time is deactivated if an inrush pickup is present since an inrush does not represent an intermittent fault.

These elements can be blocked by the automatic reclosing function (79 AR).

The pickup values of each 50-1 Element for phase currents and 50N-1 Element for the ground current and the element-specific time delays can be set individually.

The following figures show the logic diagrams for the current elements 50-1 and 50N-1.

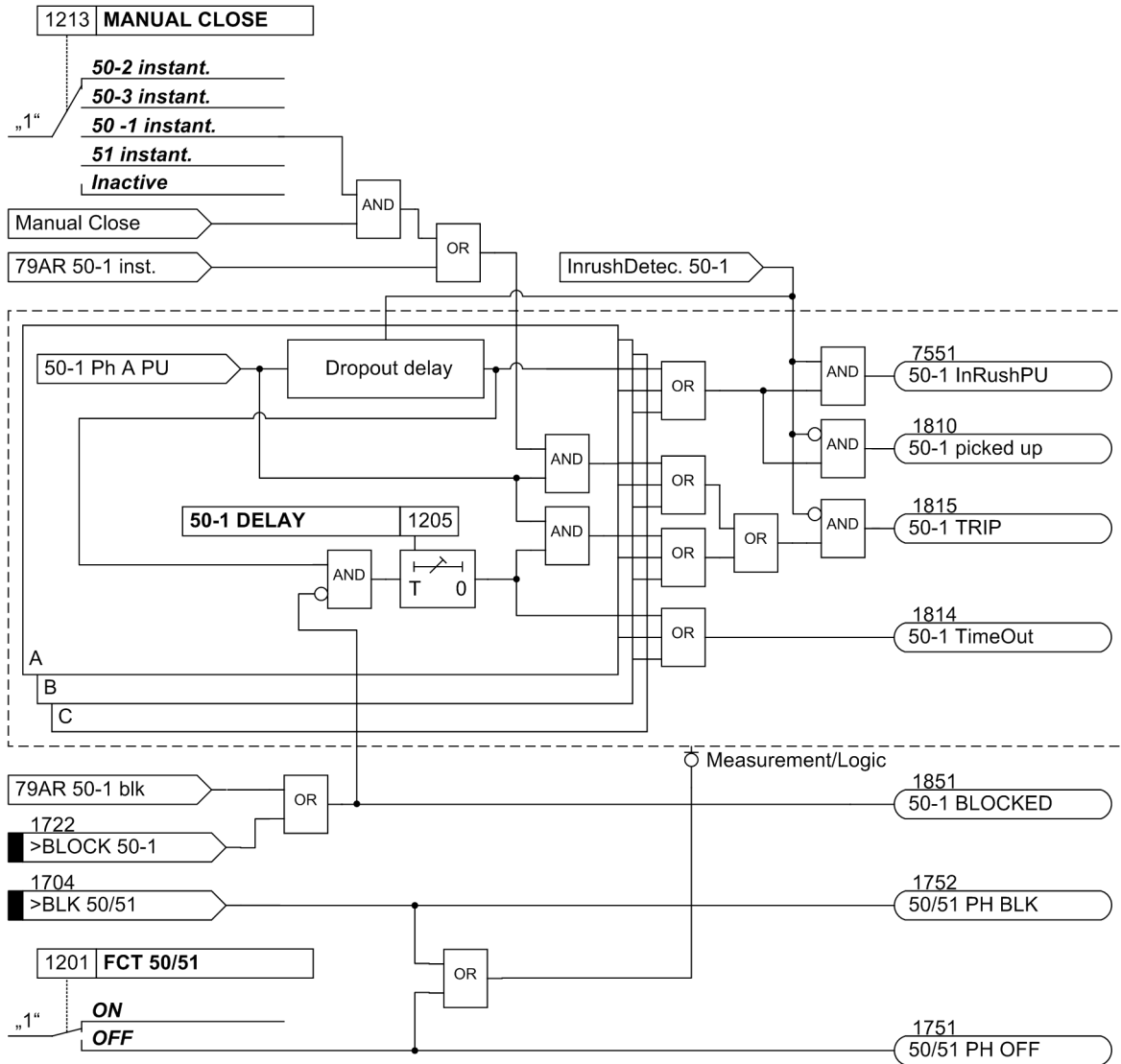

Figure 2-10 Logic diagram for the 50-1 overcurrent element for phases

If parameter 1213 **MANUAL CLOSE** is set to **50 - 1 instant.** and manual close detection is used, a pickup causes instantaneous tripping even if the Element is blocked via a binary input.

The same applies to 79 AR 50-1 inst.

The dropout delay only operates if no inrush was detected. An incoming inrush will reset a running dropout delay time.

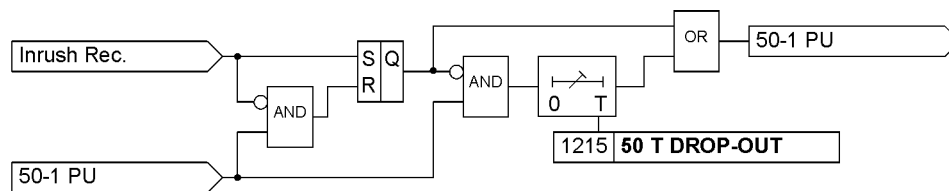

Figure 2-11 Logic diagram of the dropout delay for 50-1

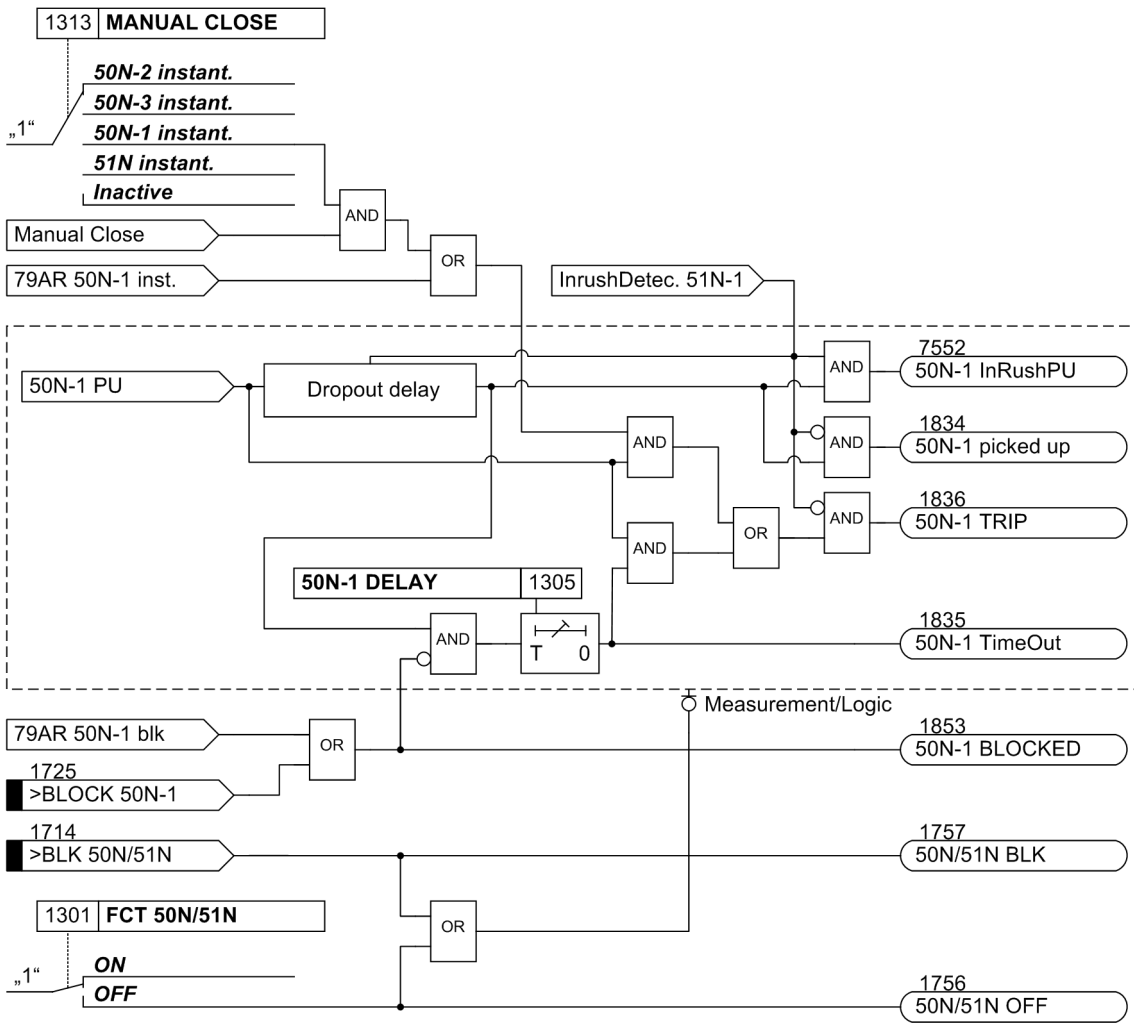

Figure 2-12 Logic diagram for the 50N-1 overcurrent current element

If parameter 1313 **MANUAL CLOSE** is set to **50N-1 instant.** and manual close detection is used, a pickup causes instantaneous tripping even if the Element is blocked via a binary input.

The same applies to 79 AR 50N-1 inst.

The pickup values of each 50-1, 50-2 Element for the phase currents and 50N-1, 50N-2 Element for the ground current and the valid delay times for each element can be set individually.

The dropout delay only functions if no inrush was detected. An incoming inrush will reset a running dropout time delay.

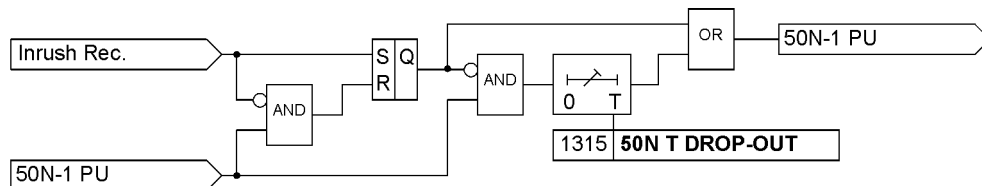

Figure 2-13 Logic of the dropout delay for 50N-1

2.2.4 Inverse Time Overcurrent Elements 51, 51N

Inverse time overcurrent elements are dependent on the ordering version. They always operate with an inverse time Curve in accordance with IEC or ANSI standards. The characteristics and associated formulas are given in the Technical Data. During configuration of the inverse time characteristics, the definite time relay elements 50-1, 50-2 and 50-3 are also enabled (see Sections "Definite Time High-set Elements 50-2, 50-3, 50N-2, 50N-3" and "Definite Time Overcurrent Elements 50-1, 50N-1").

Pickup Behavior

For each Element, an individual pickup value **51 PICKUP** or **51N PICKUP** is set. Apart from **Fundamental**, the **True RMS** can also be measured. Each phase and ground current is separately compared with the setting value 51 or 51N per Element. If a current exceeds 1.1 times the setting value, the corresponding Element picks up and is signaled individually. If the inrush restraint function is used, either the normal pickup signals or the corresponding inrush signals are issued as long as inrush current is detected. If the 51 Element picks up, the tripping time is calculated from the actual fault current flowing, using an integrating method of measurement. The calculated tripping time depends on the selected tripping curve. Once this time has elapsed, a trip signal is issued provided that no inrush current is detected or inrush restraint is disabled. If the inrush restraint function is enabled and an inrush condition exists, no tripping takes place but a message is issued indicating when the overcurrent element time delay elapses.

These elements can be blocked by the automatic reclosing feature (79 AR).

For ground current element 51N, the Curve may be selected independently of the Curve used for phase currents.

Pickup values of elements 51 (phase currents) and 51N (ground current) and the relevant time multipliers may be set individually.

The following two figures show the logic diagrams for the inverse time overcurrent protection.

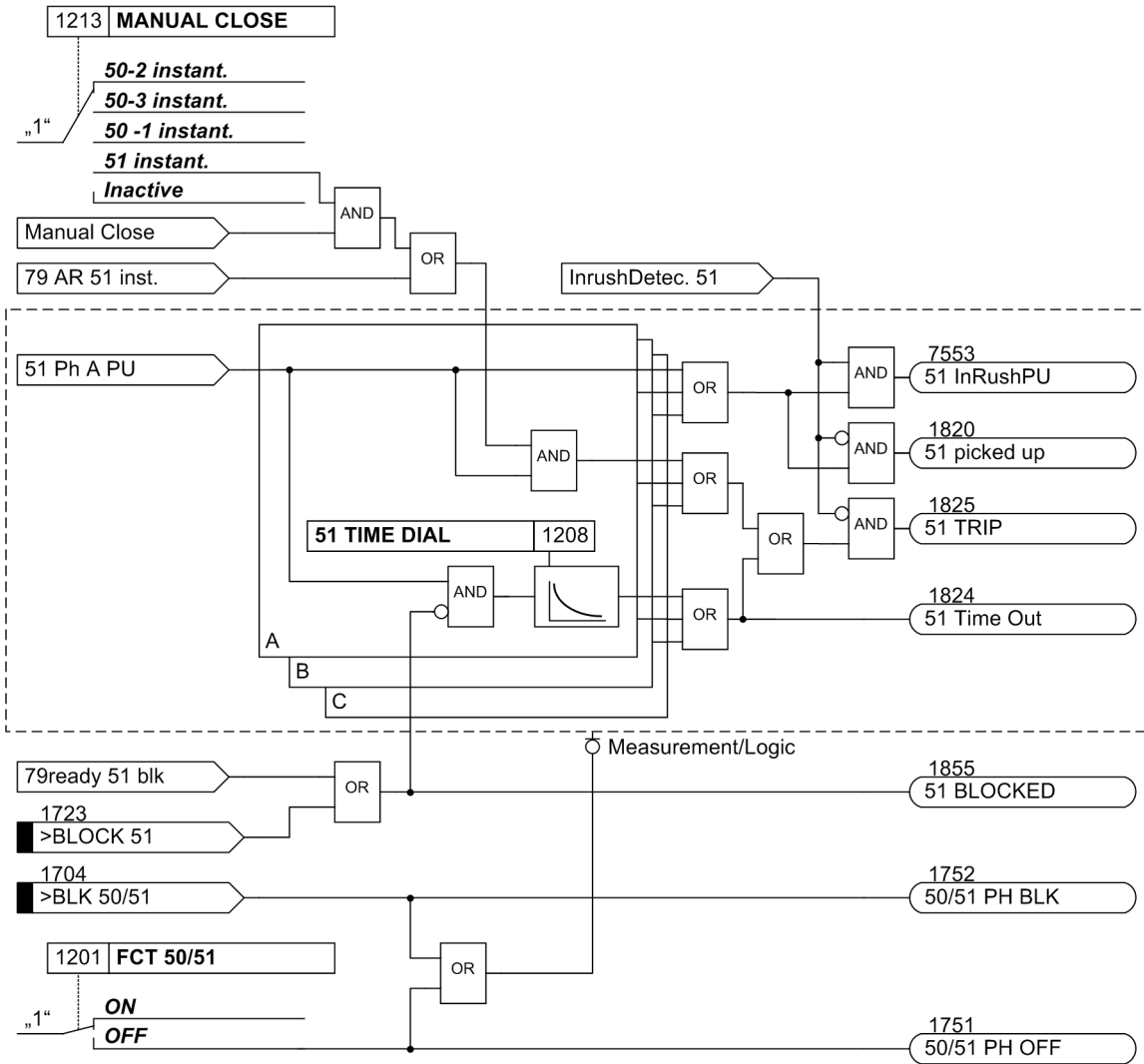

Figure 2-14 Logic diagram of the inverse-time overcurrent protection element for phases

If an ANSI Curve is configured, parameter 1209 **51 TIME DIAL** is used instead of parameter 1208 **51 TIME DIAL**.

If parameter 1213 **MANUAL CLOSE** is set to **51 instant.** and manual close detection is used, a pickup causes instantaneous tripping even if the Element is blocked via a binary input.

The same applies to 79 AR 51 inst.

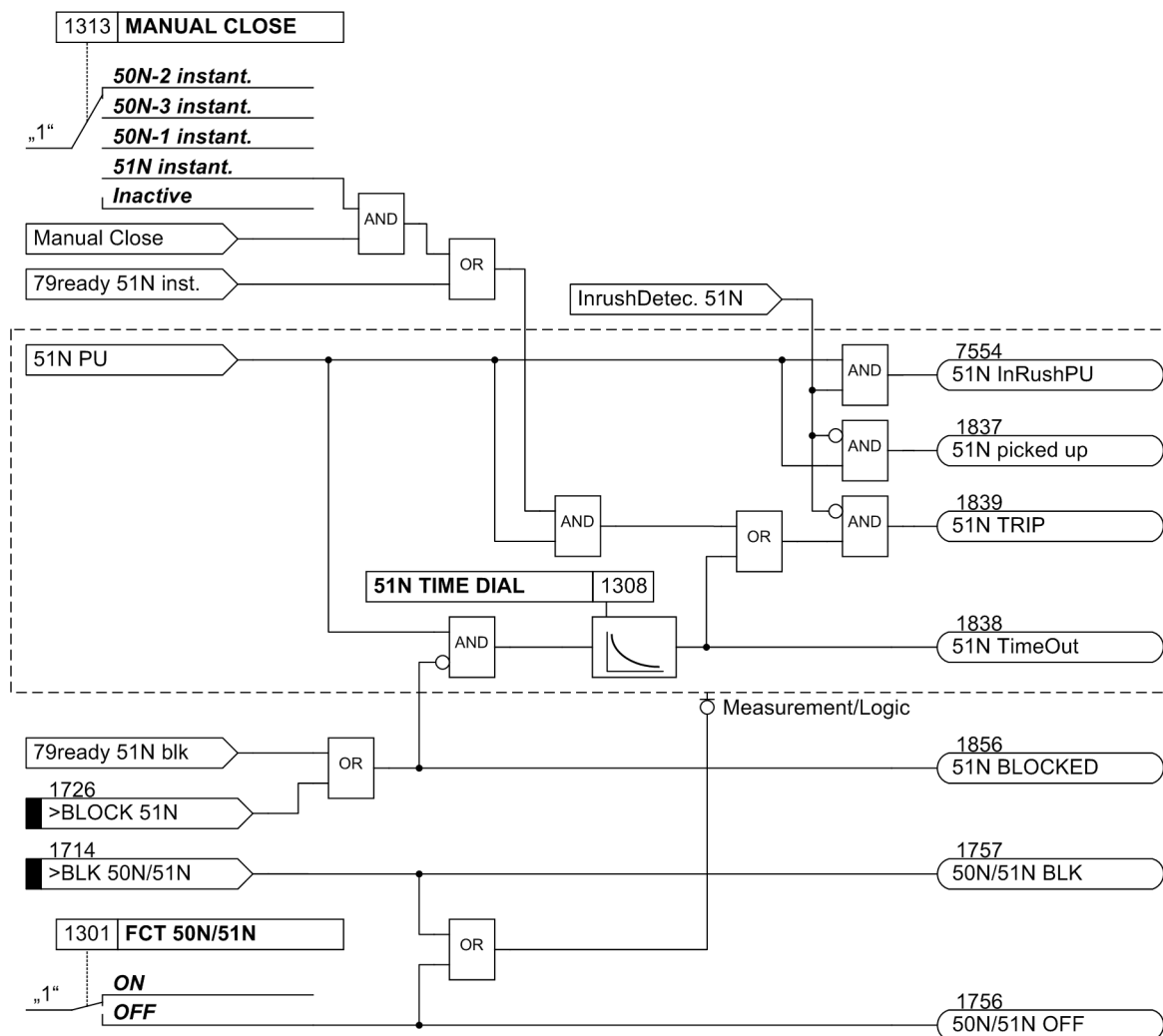

Figure 2-15 Logic diagram of the inverse-time overcurrent protection element for Ground

If an ANSI Curve is configured, parameter 1309 **51N TIME DIAL** is used instead of parameter 1308 **51N TIME DIAL**.

If parameter 1313 **MANUAL CLOSE** is set to **51N instant**, and manual close detection is used, a pickup causes instantaneous tripping even if the Element is blocked via a binary input.

The same applies to 79 AR 51N inst.

Dropout Behaviour

For the ANSI or IEC characteristics, you can select whether an Element drops out instantaneously after a threshold has been undershot or whether dropout is performed by means of disk emulation. "Instantaneous" means that the picked-up element drops out when 95 % of the pickup value is undershot. For a new pickup, the time delay starts at zero.

The disk emulation evokes a dropout process (timer counter is decrementing) which begins after de-energization. This process corresponds to the reset of a Ferraris disk (explaining its denomination "disk emulation"). In case several faults occur in succession, the "history" is taken into consideration due to the inertia of the Ferraris disk and the time response is adapted. Reset begins as soon as 90 % of the setting value is undershot, in accordance to the dropout curve of the selected characteristic. In the range between the dropout value (95 % of

the pickup value) and 90 % of the setting value, the incrementing and the decrementing processes are in idle state.

Disk emulation offers advantages when the overcurrent relay elements must be coordinated with conventional electromechanical overcurrent relays located towards the source.

2.2.5 Inverse Time Overcurrent Protection 51V (Voltage-controlled / Voltage-restraint)

Undervoltage Consideration

The inverse time overcurrent protection is provided with an undervoltage detection that can be disabled (address 1223 **VOLT. INFLUENCE**). This function can influence overcurrent detection by means of two different methods:

- **Voltage-controlled:** If a set voltage threshold is undershot, the overcurrent element is released.
- **Voltage-restraint:** The pickup threshold of the overcurrent element depends on the voltage magnitude. A lower voltage decreases the current pickup value (see Figure 2-16). In the range between $V/V_{Nom} = 1.00$ to 0.25 a linear, directly proportional dependence is realized, and therefore the following applies:

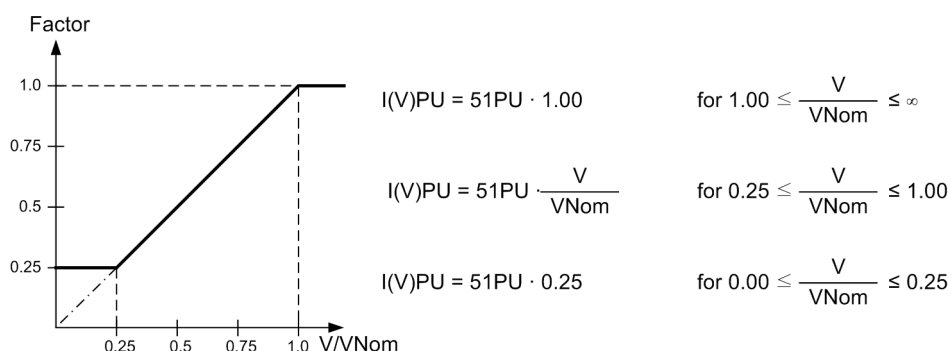

with V_{Nom} = Nominal voltage
 $51PU$ = Pick-up value of inverse time characteristic
 $I(V)PU$ = Voltage influence of the pickup value

Figure 2-16 Voltage influence of the pickup value

The 51 PICKUP value is decreased proportional to the voltage decrease. Consequently, for constant current I the $I / 51$ PICKUP ratio is increased and the tripping time is reduced. Compared with the standard curves represented in Section „Technical Data“ the tripping curve shifts to the left side as the voltage decreases.

Switching to the lower pickup value or decreasing the pickup threshold is carried out phase-selectively. The assignment of voltages to current-carrying phases is shown in the following table.

Table 2-4 Controlling voltages in relation to the fault currents

Current	Voltage
I_A	$V_A - V_B$
I_B	$V_B - V_C$
I_C	$V_C - V_A$

In order to avoid an unwanted operation in case of a voltage transformer fault, a function blocking is implemented via a binary input controlled by the voltage transformer protection breaker as well as via the device-internal measuring voltage failure detection ("Fuse Failure Monitor").

The following two figures show the logic diagrams for the inverse time overcurrent protection with undervoltage consideration.

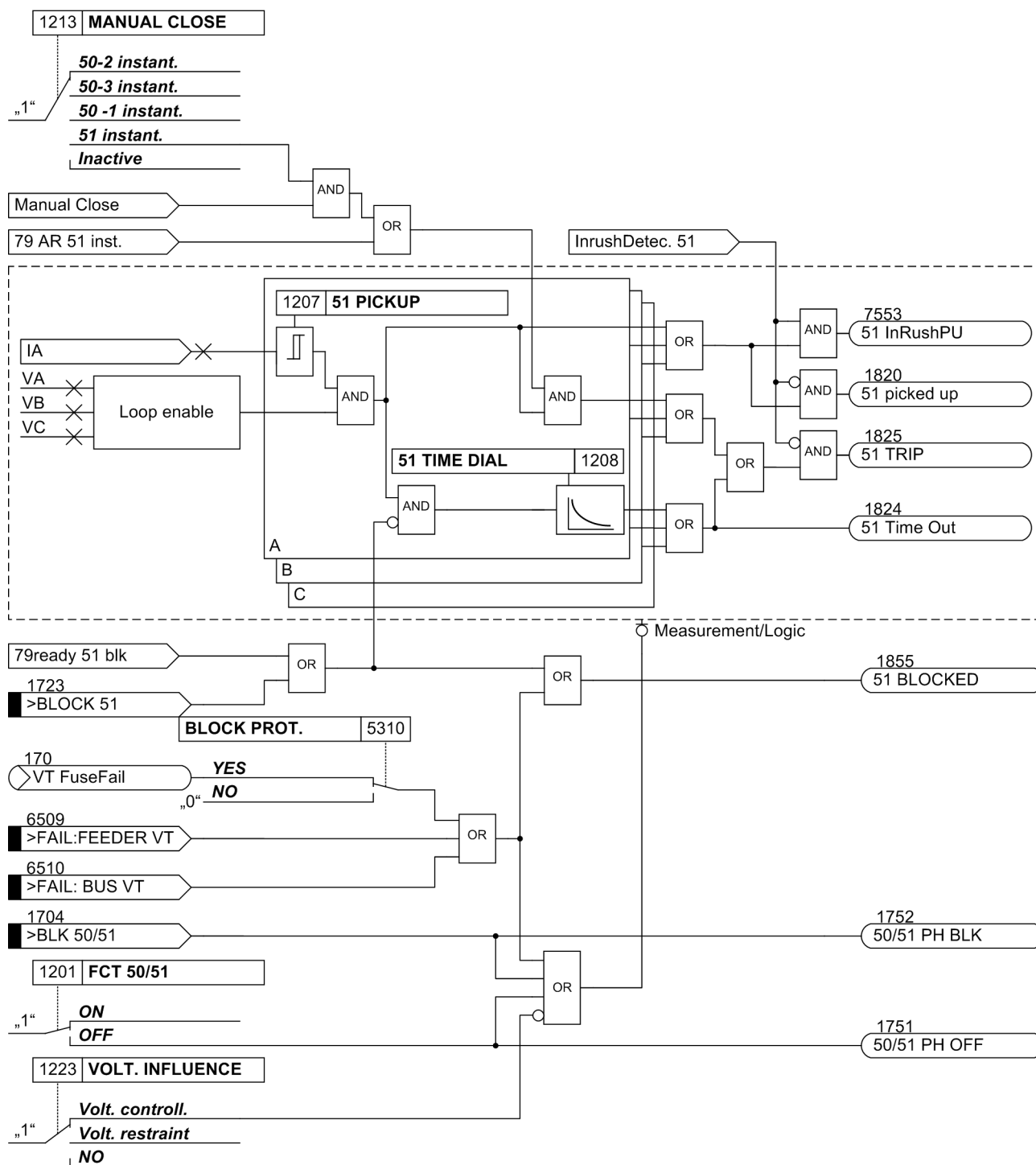

Figure 2-17 Logic diagram of the voltage-controlled inverse time overcurrent protection

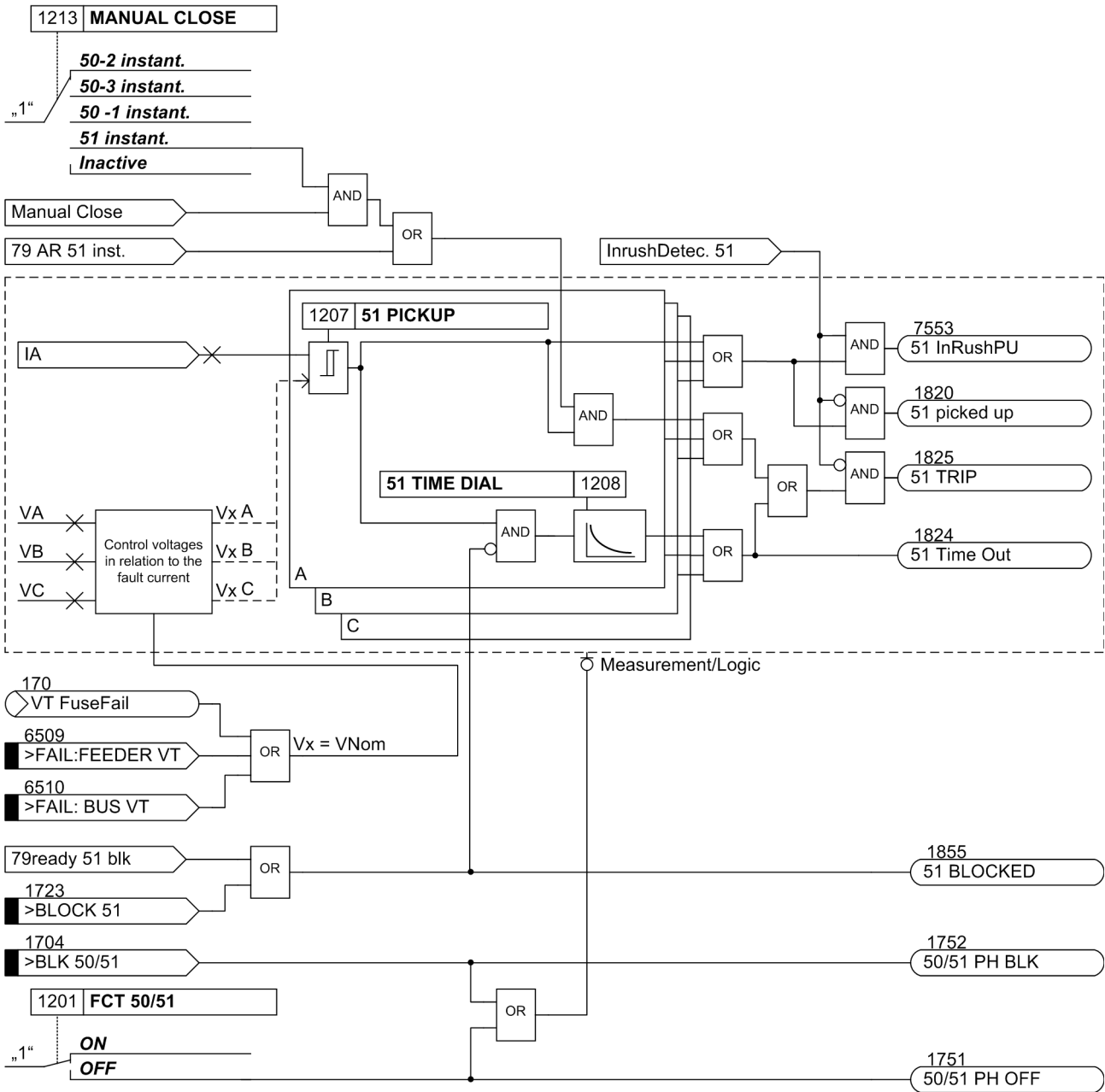

Figure 2-18 Logic diagram of the voltage-restraint inverse-time overcurrent protection

2.2.6 Dynamic Cold Load Pickup Function

It may be necessary to dynamically increase the pickup values of the overcurrent protection if, at starting, certain system components show an increased power consumption after a long period of zero voltage (e.g. air-conditioning systems, heating installations). Thus, a general increase of the pickup thresholds can be avoided taking into consideration such starting conditions.

This dynamic pickup value changeover is common to all overcurrent elements and is described in Section 2.4. The alternative pickup values can be set individually for each Element of the overcurrent protection.

2.2.7 Inrush Restraint

When the multi-functional protective relay with local control 7SJ80 is installed, for instance, to protect a power transformer, large magnetizing inrush currents will flow when the transformer is energized. These inrush currents may be several times the nominal transformer current, and, depending on the transformer size and design, may last from several tens of milliseconds to several seconds.

Although pickup of the relay elements is based only on the fundamental harmonic component of the measured currents, false device pickup due to inrush is still a potential problem since, depending on the transformer size and design, the inrush current also comprises a large component of the fundamental.

The 7SJ80 features an integrated inrush restraint function. It prevents the „normal“ pickup of 50-1 or 51 relay elements (not 50-2 and 50-3) in the phases and the ground path of all directional and non-directional overcurrent relay elements. The same is true for the alternative pickup thresholds of the dynamic cold load pickup function. After detection of inrush currents above a pickup value, special inrush signals are generated. These signals also initiate fault annunciations and start the associated trip delay time. If inrush conditions are still present after the tripping time delay has elapsed, a corresponding message („ . . . Timeout .“) is output, but the overcurrent tripping is blocked (see also logic diagrams of time overcurrent elements, Figures 2-10 to 2-15).

Inrush current contains a relatively large second harmonic component (twice the nominal frequency) which is nearly absent during a fault current. The inrush restraint is based on the evaluation of the 2nd harmonic present in the inrush current. For frequency analysis, digital filters are used to conduct a Fourier analysis of all three phase currents and the ground current.

Inrush current is recognized if the following conditions are fulfilled at the same time:

- The harmonic content is larger than the setting value 2202 **2nd HARMONIC** (minimum $0.125 * I_{Nom,sec}$);
- the currents do not exceed an upper limit value 2205 **I Max**;
- an exceeding of a threshold value via an inrush restraint of the blocked Element takes place.

In this case an inrush in the affected phase is recognized (annunciations 1840 to 1842 and 7558 „InRush Gnd Det“, see Figure 2-19) and its blocking being carried out.

Since quantitative analysis of the harmonic components cannot be completed until a full line period has been measured, pickup will generally be blocked by then. Therefore, assuming the inrush restraint feature is enabled, a pickup message will be delayed by a full line period if no closing process is present. On the other hand, trip delay times of the time overcurrent protection feature are started immediately even with the inrush restraint being enabled. Time delays continue running with inrush currents present. If inrush blocking drops out after the time delay has elapsed, tripping will occur immediately. Therefore, utilization of the inrush restraint feature will not result in any additional tripping delays. If a relay element drops out during inrush blocking, the associated time delay will reset.

Cross Blocking

Since inrush restraint operates individually for each phase, protection is ideal where a power transformer is energized into a single-phase fault and inrush currents are detected on a different healthy phase. However, the protection feature can be configured to allow that not only this phase element but also the remaining elements (including ground) are blocked (the so-called **CROSS BLOCK** function, address 2203) if the permissible harmonic component of the current is exceeded for only one phase.

Please take into consideration that inrush currents flowing in the ground path will not cross-block tripping by the phase elements.

Cross blocking is reset if there is no more inrush in any phase. Furthermore, the cross blocking function may also be limited to a particular time interval (address 2204 **CROSS BLK TIMER**). After expiry of this time interval, the cross blocking function will be disabled, even if inrush current is still present.

The inrush restraint has an upper limit: Above this (via adjustable parameter 2205 **I Max**) current blocking is suppressed since a high-current fault is assumed in this case.

The following figure shows the inrush restraint influence on the time overcurrent elements including cross-blocking.

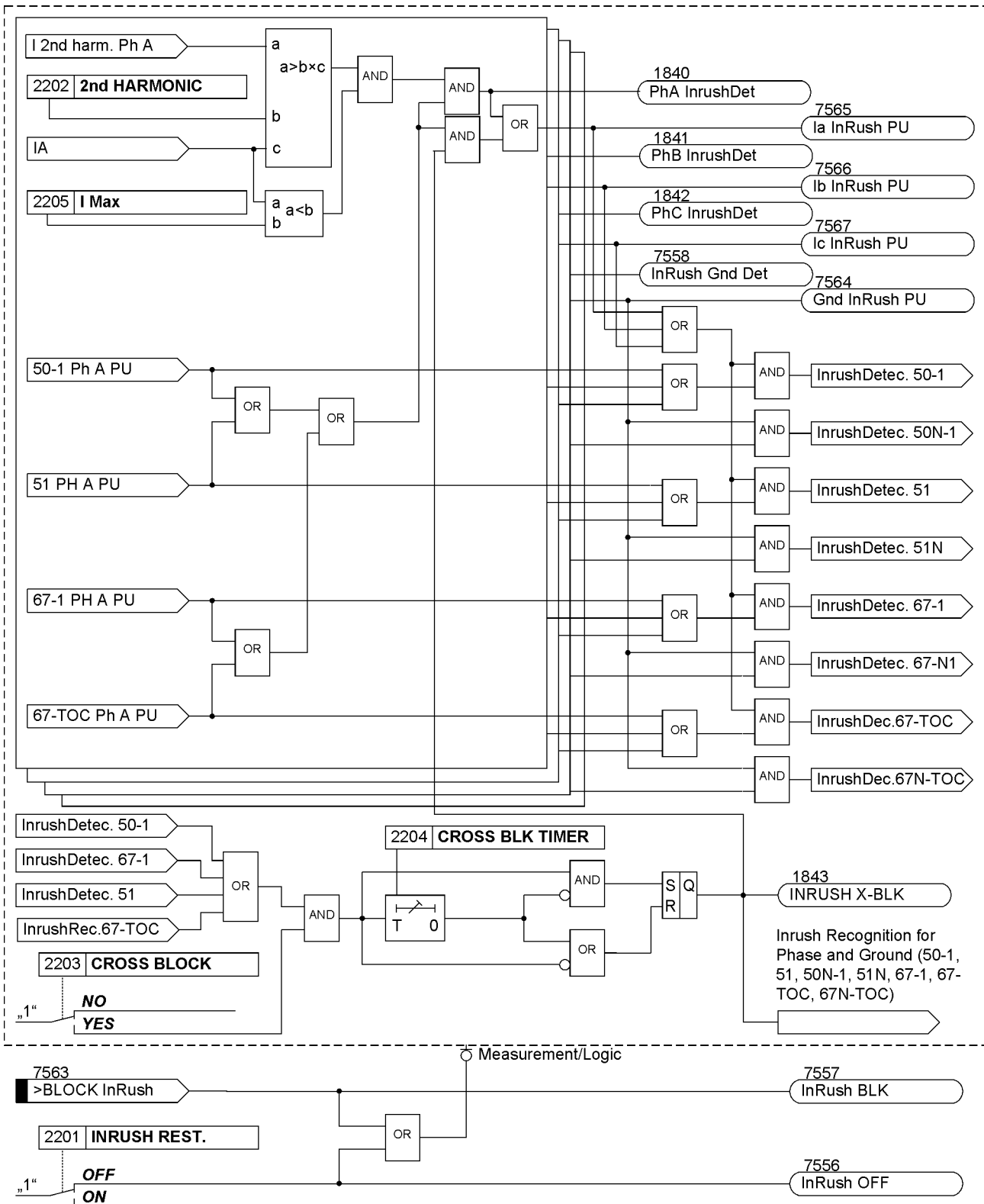

Figure 2-19 Logic diagram for inrush restraint

2.2.8 Pickup Logic and Tripping Logic

The pickup annunciations of the individual phases (or Ground) and the individual elements are combined with each other in such a way that the phase information and the Element that has picked up are issued.

Table 2-5 Pickup Indications of Overcurrent Protection

Internal indication	Display	Output indication	FNo.
50-3 A PU 50-2 A PU 50-1 A PU 51 A PU	2-8 2-10 2-14	„50/51 Ph A PU“	1762
50-3 B PU 50-2 BPU 50-1B PU 51 B PU	2-8 2-10 2-14	„50/51 Ph B PU“	1763
50-3 C PU 50-2 C PU 50-1 C PU 51 C PU	2-8 2-10 2-14	„50/51 Ph C PU“	1764
50N-3 PU 50N-2 PU 50N-1 PU 51N PU	2-9 2-12 2-15	„50N/51NPickedup“	1765
50-3 A PU 50-3 B PU 50-3 C PU		„50-3 picked up“	1767
50N-3 PU		„50N-3 picked up“	1768
50-2 A PU 50-2 B PU 50-2 C PU	2-8 2-8 2-8	„50-2 picked up“	1800
50N-2 PU	2-9	„50N-2 picked up“	1831
50-1 A PU 50-1 B PU 50-1 C PU	2-10 2-10 2-10	„50-1 picked up“	1810
50N-1 PU	2-9	„50N-1 picked up“	1834
51 A PU 51 B PU 51 C PU	2-14 2-14 2-14	„51 picked up“	1820
51N PU	2-15	„51N picked up“	1837
(All pickups)		„50(N)/51(N) PU“	1761

In the trip signals, the Element which initiated the tripping is also indicated.

2.2.9 Two-phase Time Overcurrent Protection (only non-directional)

The 2-phase overcurrent protection functionality is used in isolated or grounded systems where interaction with existing 2-phase protection equipment is required. As an isolated or grounded system remains operational with a 1-phase ground fault, this protection serves to detect double ground faults with high ground fault currents. The respective feeder must be switched off only in this case. A 2-phase measurement is sufficient for this purpose. In order to ensure selectivity of the protection in this section of the system, only phases A and C are monitored.

If 250 **50/51 2-ph prot** (to be set under **P.System Data 1**) is set to **ON**, I_B is not used for threshold value comparison. If the fault is a simple ground fault in B, no tripping occurs. Only in the case of a tripping on A or C, a double ground fault is assumed. This leads to a pickup and after expiry of the time delay to a tripping.



Note

With inrush detection activated and inrush only on B, no cross blocking will take place in the other phases. On the other hand, if inrush with cross blocking is activated on A or C, B will also be blocked.

2.2.10 Fast Busbar Protection Using Reverse Interlocking

Application Example

Each of the current elements can be blocked via binary inputs. A setting parameter determines whether the binary input operates in the normally open (i.e. actuated when energized) or the normally closed (i.e. actuated when de-energized) mode. This allows fast busbar protection to be applied in star systems or open ring systems by applying "reverse interlocking". This principle is often used, for example, in distribution systems, auxiliary systems of power plants and similar systems, where a station supply transformer supplied from the transmission grid serves internal loads of the generation station via a medium voltage bus with multiple feeders (Figure 2-20).

The reverse interlocking principle is based on the following: Time overcurrent protection of the busbar feeder trips with a short time delay T 50-2 independent of the grading times of the feeders, unless the pickup of the next load-side overcurrent protection element blocks the busbar protection (Figure 2-20). Always the protection element nearest to the fault will trip with the short time delay since this element cannot be blocked by a protection element located behind the fault. Time elements T 50-1 or T51 are still effective as backup element. Pickup signals output by the load-side protective relay are used as input message „>BLOCK 50 -2“ via a binary input at the feeder-side protective relay.

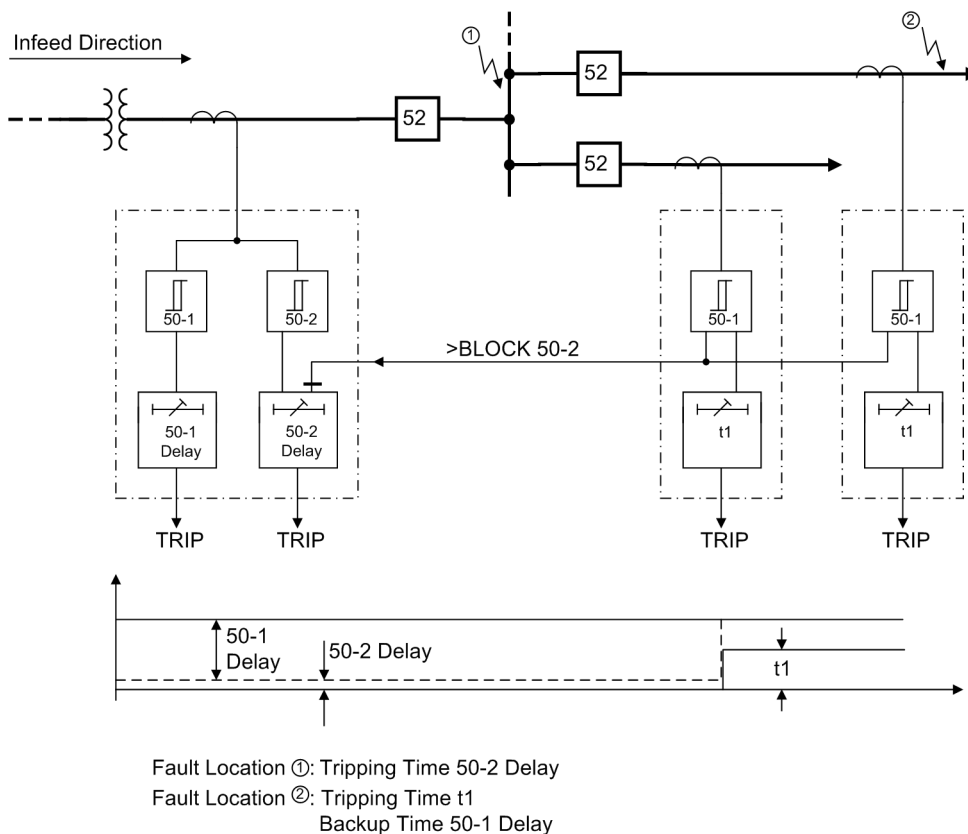

Figure 2-20 Reverse interlocking protection scheme

2.2.11 Setting Notes

General

When selecting the time overcurrent protection in DIGSI, a dialog box appears with several tabs for setting the individual parameters. Depending on the functional scope specified during configuration of the protection functions under addresses 112 **Charac. Phase** and 113 **Charac. Ground**, the number of tabs can vary. If address **FCT 50/51** was set to **Definite Time**, or **Charac. Ground** was set to **Definite Time**, then only the settings for the definite time elements are available. The selection of **TOC IEC** or **TOC ANSI** makes available additional inverse time characteristics. The superimposed high-set elements 50-2, 50-3 or 50N-2, 50N-3 are available in all these cases.

Parameter 250 **50/51 2-ph prot** can also be set to activate two-phase overcurrent protection.

Under address 1201 **FCT 50/51**, overcurrent protection for phases and under address 1301 **FCT 50N/51N**, the ground overcurrent protection can be switched **ON** or **OFF**.

Pickup values, time delays, and Curves for ground protection are set separately from the pickup values, time delays and characteristic curves associated with phase protection. Because of this, relay coordination for ground faults is independent of relay coordination for phase faults, and more sensitive settings can often be applied to directional ground protection.

Depending on the setting of parameter 251 **CT Connect.**, the device can also be used in specific system configuration with regard to current connections. Further information can be found under Section 2.1.3.2, „Current Connections“.

Measurement Methods

The comparison values to be used for the respective element can be set in the setting sheets for the elements.

- Measurement of the **fundamental harmonic** (standard method):
This measurement method processes the sampled values of the current and filters in numerical order the fundamental harmonic so that the higher harmonics or transient peak currents remain largely unconsidered.
- Measurement of the **true RMS value**
The current amplitude is derived from the sampled values in accordance with the definition equation of the true RMS value. This measurement method should be selected when higher harmonics are to be considered by the function (e.g. in capacitor banks).
- Measurement with **instantaneous values**
This procedure compares the instantaneous values to the set threshold. The element picks up at $2 \cdot \sqrt{2} \cdot$ setting value (rms). It does not perform a mean-value calculation and is thus sensitive with regard to disturbances. This measurement method should only be selected if an especially short pickup time of the element is required. In this measurement procedure, the operating time of the element is reduced compared to the measurement of effective values or fundamental harmonics (see „Technical Data“).

The type of the comparison values can be set under the following addresses:

- 50-3 Element Address 1219 **50-3 measurement.**
- 50-2 Element Address 1220 **50-2 measurement.**
- 50-1 Element Address 1221 **50-1 measurement.**
- 51 Element Address 1222 **51 measurement.**
- 50N-3 Element Address 1319 **50N-3 measurement.**
- 50N-2 Element Address 1320 **50N-2 measurement.**
- 50N-1 Element Address 1321 **50N-1 measurement.**
- 51N Element Address 1322 **51N measurement.**

High Current Elements 50-2, 50-3 (Phases)

The pickup current of the high-set element **50-2 PICKUP** or **50-3 PICKUP** can be set at address 1202 or 1217. The corresponding delay time **50-2 DELAY** or **50-3 DELAY** can be configured under address 1203 or 1218. It is usually used for purposes of current grading intended for large impedances that are prevalent in transformers or generators. It is specified in such manner that it picks up faults up to this impedance.

Example of the high-set current element **50-2 PICKUP**: Transformer used for busbar supply with the following data:

Rated apparent power	$S_{NomT} = 16 \text{ MVA}$
Transformer impedance	$ZT = 10 \%$
Primary nominal voltage	$V_{Nom1} = 110 \text{ kV}$
Secondary nominal voltage	$V_{Nom2} = 20 \text{ kV}$
Vector groups	Dy 5
Neutral point	Grounded
Fault power on 110 kV-side	1 GVA

Based on the data above, the following fault currents are calculated:

Three-Phase High Voltage Side Fault Current	at 110 kV = 5250 A
Three-Phase Low Voltage Side Fault Current	at 20 kV = 3928 A
On the High Voltage Side Flowing	at 110 kV = 714 A

The nominal current of the transformer is:

$I_{NomT, 110} = 84 \text{ A (High Voltage Side)}$	$I_{NomT, 20} = 462 \text{ A (Low Voltage Side)}$
Current Transformer (High Voltage Side)	100 A/1 A
Current Transformer (Low Voltage Side)	500 A/1 A

Due to the following definition

$$\text{High-set Element 50-2 PICKUP} \quad \frac{50-2}{I_{Nom}} > \frac{1}{V_{kTransf}} \cdot \frac{I_{NomTransf}}{I_{NomCT}}$$

the following setting applies to the protection device: The 50-2 high-set current element must be set higher than the maximum fault current which is detected during a low side fault on the high side. To reduce fault probability as much as possible even when fault power varies, the following setting is selected in primary values: $50-2 / I_{Nom} = 10$, i.e. $50-2 = 1000 \text{ A}$. The same applies analogously when using the high-set element 50-3.

Increased inrush currents, if their fundamental component exceeds the setting value, are rendered harmless by delay times (address 1203 **50-2 DELAY** or 1218 **50-3 DELAY**).

The principle of the "reverse interlocking" utilizes the multi-element function of the time overcurrent protection: Element **50-2 PICKUP** is applied as a fast busbar protection with a shorter safety delay time **50-2 DELAY** (e.g. 100 ms). For faults at the outgoing feeders, element 50-2 is blocked. The Elements 50-1 or 51 serve as backup protection. The pickup values of both elements (50-1 PICKUP or 51 PICKUP and 50-2 PICKUP) are set equal. The delay time **50-1 DELAY** or **51 TIME DIAL** is set in such manner that it overgrades the delay for the outgoing feeders.

The selected time is an additional delay time and does not include the operating time (measuring time, dropout time). The delay can also be set to ∞ . In this case, the Element will not trip after pickup. However, pickup, will be signaled. If the 50-2 Element or the 50-3 Element is not required at all, the pickup threshold 50-2 or 50-3 is set to ∞ . This setting prevents tripping and the generation of a pickup message.

High Current Elements 50N-2, 50N-3 (Ground)

The pickup current of the high-set element **50N-2 PICKUP** or **50N-3 PICKUP** can be set at address 1302 or 1317. The corresponding delay time **50N-2 DELAY** or **50N-3 DELAY** can be configured under address 1303 or 1318. The same considerations apply to these settings as they did for phase currents discussed earlier.

The selected time is an additional delay time and does not include the operating time (measuring time, dropout time). The delay can also be set to ∞ . In this case, the Element will not trip after pickup. However, pickup, will be signaled. If the 50N-2 Element or 50N-3 Element is not required at all, the pickup threshold 50N-2 or 50N-3 should be set to ∞ . This setting prevents tripping and the generation of a pickup message.

50-1 Element (phases)

For setting the 50-1 element, it is the maximum anticipated load current that must be considered above all. Pickup due to overload should never occur since in this mode the device operates as fault protection with correspondingly short tripping times and not as overload protection. For this reason, a setting equal to 20% of the expected peak load is recommended for line protection, and a setting equal to 40% is recommended for transformers and motors.

The settable time delay (address 1205 **50-1 DELAY**) results from the grading coordination chart defined for the system.

The selected time is an additional delay time and does not include the operating time (measuring time, dropout time). The delay can also be set to ∞ . In this case, the Element will not trip after pickup. However, pickup, will

be signaled. If the 50-1 Element is not required at all, then the pickup threshold 50-1 should be set to ∞ . This setting prevents tripping and the generation of a pickup message.

50N-1 Element (Ground)

The 50N-1 element is normally set based on minimum ground fault current.

If the relay is used to protect transformers or motors with large inrush currents, the inrush restraint feature of 7SJ80 may be used for the 50N-1 relay element. It can be enabled or disabled for both the phase current and the ground current in address 2201 **INRUSH REST**. The characteristic values of the inrush restraint are listed in Subsection "Inrush Restraint".

The settable delay time (address 1305 **50N-1 DELAY**) results from the time coordination chart defined for the system. For ground currents in a grounded system a separate coordination timer with short time delays can be applied.

The selected time is an additional delay time and does not include the operating time (measuring time, dropout time). The delay can also be set to ∞ . In this case, the Element will not trip after pickup. However, pickup will be signaled. If the 50N-1 Element is not required at all, the pickup threshold 50N-1 PICKUP should be set to ∞ . This setting prevents tripping and the generation of a pickup message.

Pickup Stabilization (Definite Time)

The configurable dropout times 1215 **50 T DROP-OUT** or 1315 **50N T DROP-OUT** can be set to implement a uniform dropout behavior when using electromechanical relays. This is necessary for a time grading. The dropout time of the electromechanical relay must be known to this end. Subtract the dropout time of the device (see Technical Data) from this value and enter the result in the parameters.

51 Element (phases) with IEC or ANSI characteristics

Having set address 112 **Charac. Phase = TOC IEC** or **TOC ANSI** when configuring the protection functions (Section 2.1.1.2), the parameters for the inverse time characteristics will also be available.

If address 112 **Charac. Phase** was set to **TOC IEC**, you can select the desired IEC Curve (**Normal Inverse, Very Inverse, Extremely Inv. or Long Inverse**) at address 1211 **51 IEC CURVE**. If address 112 **Charac. Phase** was set to **TOC ANSI**, you can select the desired ANSI Curve (**Very Inverse, Inverse, Short Inverse, Long Inverse, Moderately Inv., Extremely Inv. or Definite Inv.**) at address 1212 **51 ANSI CURVE**.

If the inverse time trip characteristic is selected, it must be noted that a safety factor of about 1.1 has already been included between the pickup value and the setting value. This means that a pickup will only occur if a current of about 1.1 times the setting value is present. If **Disk Emulation** was selected at address 1210 **51 Drop-out**, reset will occur in accordance with the reset curve as described before.

The current value is set in address 1207 **51 PICKUP**. The setting is mainly determined by the maximum anticipated operating current. Pickup due to overload should never occur since in this mode, the device operates as fault protection with correspondingly short tripping times and not as overload protection.

The corresponding time multiplier for an IEC Curve is set at address 1208 **51 TIME DIAL** and in address 1209 **51 TIME DIAL** for an ANSI Curve. It must be coordinated with the time coordination chart of the system.

The time multiplier can also be set to ∞ . In this case, the Element will not trip after pickup. However, pickup will be signaled. If the 51 Element is not required at all, address 112 **Charac. Phase** should be set to **Definite Time** during protection function configuration (see Section 2.1.1.2).

If highly sensitive settings close to the load current are required in weak power systems or transformers, the element can be stabilized via the undervoltage as an additional criterion for the power system fault. The operating modes can be set in address 1223 **VOLT. INFLUENCE**. In a voltage-controlled operation, the voltage threshold is defined via parameter 1224 **51V V<** below which the current element is released.

51N Element (Ground) with IEC or ANSI Characteristics

Having set address 113 **Charac. Ground = TOC IEC** when configuring the protection functions (Section 2.1.1), the parameters for the inverse time characteristics will also be available. Specify in address 1311 **51N IEC CURVE** the desired IEC Curve (*Normal Inverse, Very Inverse, Extremely Inv. or Long Inverse*). If address 113 **Charac. Ground** was set to **TOC ANSI**, you can select the desired ANSI Curve (*Very Inverse, Inverse, Short Inverse, Long Inverse, Moderately Inv., Extremely Inv. or Definite Inv.*) in address 1312 **51N ANSI CURVE**.

If the inverse time trip characteristic is selected, it must be noted that a safety factor of about 1.1 has already been included between the pickup value and the setting value. This means that a pickup will only occur if a current of about 1.1 times the setting value is present. If **Disk Emulation** was selected at address 1310 **51 Drop-out**, reset will occur in accordance with the reset curve as described before.

The current value is set in address 1307 **51N PICKUP**. The setting is mainly determined by the minimum anticipated ground fault current.

The corresponding time multiplier for an IEC Curve is set at address 1308 **51N TIME DIAL** and at address 1309 **51N TIME DIAL** for an ANSI Curve. This has to be coordinated with the grading coordination chart of the network. For ground currents with grounded network, you can often set up a separate grading coordination chart with shorter delay times.

The time multiplier can also be set to ∞ . In this case, the Element will not trip after pickup. However, pickup will be signaled. If the 51N-TOC Element is not required at all, address 113 **Charac. Ground** should be set to **Definite Time** during configuration of the protection functions (see Section 2.1.1).

Inrush Restraint

When applying the protection device to transformers where high inrush currents are to be expected, the 7SJ80 can make use of an inrush restraint function for the overcurrent elements 50-1, 51, 50N-1 and 51N.

Inrush restraint is only effective and accessible if address 122 **InrushRestraint** was set to **Enabled**. If this function is not required, then **Disabled** is set. In address 2201 **INRUSH REST.**, the function is switched **ON** or **OFF** jointly for the overcurrent elements **50-1 PICKUP, 51 PICKUP, 50N-1 PICKUP, and 51N PICKUP**

The inrush restraint is based on the evaluation of the 2nd harmonic present in the inrush current. Upon delivery from the factory, a ratio I_{2f}/I_f of 15 % is set. Under normal circumstances, this setting will not need to be changed. The setting value is identical for all phases and Ground. However, the component required for restraint may be adjusted to system conditions in address 2202 **2nd HARMONIC**. To provide more restraint in exceptional cases, where energizing conditions are particularly unfavorable, a smaller value can be set in the aforementioned address, e.g. 12 %. Irrespective of parameter 2202 **2nd HARMONIC**, rush blocking will only occur if the absolute value of the 2nd harmonic is at least $0.125 * I_{Nom,sec}$.

The effective duration of the cross-blocking 2203 **CROSS BLK TIMER** can be set to a value between 0 s (harmonic restraint active for each phase individually) and a maximum of 180 s (harmonic restraint of a phase blocks also the other phases for the specified duration).

If the current exceeds the value set in address 2205 **I Max**, no further restraint will take place for the 2nd harmonic.

Manual Close Mode (phases,Ground)

When a circuit breaker is closed onto a faulted line, a high-speed trip by the circuit breaker is usually desired. For overcurrent or high-set Element the delay may be bypassed via a Manual Close pulse, thus resulting in instantaneous tripping. This pulse is prolonged by at least 300 ms. To enable the device to react properly on occurrence of a fault in the phase element, address 1213 **MANUAL CLOSE** has to be set accordingly. Correspondingly, address 1313 **MANUAL CLOSE** is considered for the ground path address. Thus, the user determines for both elements, the phase and the Ground element, what pickup value is active with what delay when the circuit breaker is closed manually.

External Control Command

If the manual close signal is not sent from 7SJ80 device, i.e. neither via the built-in operator interface nor via a serial interface, but directly from a control acknowledgment switch, this signal must be passed to a 7SJ80 binary input, and configured accordingly („>Manual Close“), so that the Element selected for **MANUAL CLOSE** can become effective. The alternative **Inactive** means that all elements operate as per configuration even with manual close and do not get special treatment.

Internal Control Function

If the manual close signal is sent via the internal control function of the device, an internal connection of information has to be established via CFC (interlocking task level) using the CMD_Information block (see Figure 2-21).

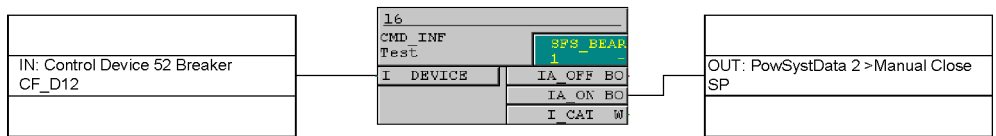

Figure 2-21 Example for the generation of a manual close signal using the internal control function



Note

For an interaction between the automatic reclosing function (79 AR) and the control function, an extended CFC logic is necessary. See margin heading „Close command: Directly or via Control“ in the Setting Notes of the automatic reclosing function (Section 2.15.6).

Interaction with the Automatic Reclosing Function (phases)

If reclosing follows, high-speed and simultaneous protection against faults with 50-2 or 50-3 is usually desired. If the fault still exists after the first reclosing, the 50-1 or the 51 element will be initiated with graded tripping times, that is, element 50-2 or 50-3 will be blocked. You can use the parameters 1214 **50-2 active** or 1216 **50-3 active** for this purpose to define whether or not the 50-2 or the 50-3 element is impacted by a release signal of the internal or an external automatic reclosing system. The setting **with 79 active** means that the 50-2 or the 50-3 element will only be released if automatic reclosing is not blocked. If this is not desired, the setting **Always** is selected so that the 50-2 or the 50-3 element is always active.

The integrated automatic reclosing function of 7SJ80 also provides the option to individually determine for each overcurrent element whether tripping or blocking is to be carried out instantaneously or unaffected by the AR with the set time delay (see Section 2.15).

Interaction with the Automatic Reclosing Function (Ground)

When reclosing occurs, it is desirable to have high-speed protection against faults with 50N-2 or 50N-3. If the fault still exists after the first reclosing, the 50N-1 or the 51N element will be initiated with coordinated tripping times, that is, element 50N-2 or 50N-3 will be blocked. At address 1314 **50N-2 active** or 1316 **50N-3 active** it can be specified whether the 50N-2 or the 50N-3 element should be influenced by the release signal of an internal or external automatic reclosing system. Address **with 79 active** determines that the 50N-2 or the 50N-3 element will only operate if automatic reclosing is not blocked. If not desired, select the setting **Always** so that the 50N-2 or the 50N-3 element will always operate, as configured.

The integrated automatic reclosing function of 7SJ80 also provides the option to individually determine for each overcurrent element whether tripping or blocking is to be carried out instantaneously or unaffected by the AR with the set time delay (see Section 2.15).

2.2.12 Settings

Addresses which have an appended "A" can only be changed with DIGSI, under "Display Additional Settings".

The table indicates region-specific default settings. Column C (configuration) indicates the corresponding secondary nominal current of the current transformer.

Addr.	Parameter	C	Setting Options	Default Setting	Comments
1201	FCT 50/51		ON OFF	ON	50, 51 Phase Time Overcurrent
1202	50-2 PICKUP	1A	0.10 .. 35.00 A; ∞	4.00 A	50-2 Pickup
		5A	0.50 .. 175.00 A; ∞	20.00 A	
1203	50-2 DELAY		0.00 .. 60.00 sec; ∞	0.00 sec	50-2 Time Delay
1204	50-1 PICKUP	1A	0.10 .. 35.00 A; ∞	1.00 A	50-1 Pickup
		5A	0.50 .. 175.00 A; ∞	5.00 A	
1205	50-1 DELAY		0.00 .. 60.00 sec; ∞	0.50 sec	50-1 Time Delay
1207	51 PICKUP	1A	0.10 .. 4.00 A	1.00 A	51 Pickup
		5A	0.50 .. 20.00 A	5.00 A	
1208	51 TIME DIAL		0.05 .. 3.20 sec; ∞	0.50 sec	51 Time Dial
1209	51 TIME DIAL		0.50 .. 15.00 ; ∞	5.00	51 Time Dial
1210	51 Drop-out		Instantaneous Disk Emulation	Disk Emulation	Drop-out characteristic
1211	51 IEC CURVE		Normal Inverse Very Inverse Extremely Inv. Long Inverse	Normal Inverse	IEC Curve
1212	51 ANSI CURVE		Very Inverse Inverse Short Inverse Long Inverse Moderately Inv. Extremely Inv. Definite Inv.	Very Inverse	ANSI Curve
1213A	MANUAL CLOSE		50-3 instant. 50-2 instant. 50 -1 instant. 51 instant. Inactive	50-2 instant.	Manual Close Mode
1214A	50-2 active		Always with 79 active	Always	50-2 active
1215A	50 T DROP-OUT		0.00 .. 60.00 sec	0.00 sec	50 Drop-Out Time Delay
1216A	50-3 active		Always with 79 active	Always	50-3 active
1217	50-3 PICKUP	1A	1.00 .. 35.00 A; ∞	∞ A	50-3 Pickup
		5A	5.00 .. 175.00 A; ∞	∞ A	
1218	50-3 DELAY		0.00 .. 60.00 sec; ∞	0.00 sec	50-3 Time Delay

Addr.	Parameter	C	Setting Options	Default Setting	Comments
1219A	50-3 measurem.		Fundamental True RMS Instantaneous	Fundamental	50-3 measurement of
1220A	50-2 measurem.		Fundamental True RMS	Fundamental	50-2 measurement of
1221A	50-1 measurem.		Fundamental True RMS	Fundamental	50-1 measurement of
1222A	51 measurem.		Fundamental True RMS	Fundamental	51 measurement of
1223	VOLT. INFLUENCE		NO Volt. controll. Volt. restraint	NO	51V Voltage Influence
1224	51V V<		10.0 .. 125.0 V	75.0 V	51V V< Threshold for Release Ip
1301	FCT 50N/51N		ON OFF	ON	50N, 51N Ground Time Overcurrent
1302	50N-2 PICKUP	1A	0.05 .. 35.00 A; ∞	0.50 A	50N-2 Pickup
		5A	0.25 .. 175.00 A; ∞	2.50 A	
1303	50N-2 DELAY		0.00 .. 60.00 sec; ∞	0.10 sec	50N-2 Time Delay
1304	50N-1 PICKUP	1A	0.05 .. 35.00 A; ∞	0.20 A	50N-1 Pickup
		5A	0.25 .. 175.00 A; ∞	1.00 A	
1305	50N-1 DELAY		0.00 .. 60.00 sec; ∞	0.50 sec	50N-1 Time Delay
1307	51N PICKUP	1A	0.05 .. 4.00 A	0.20 A	51N Pickup
		5A	0.25 .. 20.00 A	1.00 A	
1308	51N TIME DIAL		0.05 .. 3.20 sec; ∞	0.20 sec	51N Time Dial
1309	51N TIME DIAL		0.50 .. 15.00 ; ∞	5.00	51N Time Dial
1310	51N Drop-out		Instantaneous Disk Emulation	Disk Emulation	Drop-Out Characteristic
1311	51N IEC CURVE		Normal Inverse Very Inverse Extremely Inv. Long Inverse	Normal Inverse	IEC Curve
1312	51N ANSI CURVE		Very Inverse Inverse Short Inverse Long Inverse Moderately Inv. Extremely Inv. Definite Inv.	Very Inverse	ANSI Curve
1313A	MANUAL CLOSE		50N-3 instant. 50N-2 instant. 50N-1 instant. 51N instant. Inactive	50N-2 instant.	Manual Close Mode
1314A	50N-2 active		Always With 79 Active	Always	50N-2 active

Addr.	Parameter	C	Setting Options	Default Setting	Comments
1315A	50N T DROP-OUT		0.00 .. 60.00 sec	0.00 sec	50N Drop-Out Time Delay
1316A	50N-3 active		Always with 79 active	Always	50N-3 active
1317	50N-3 PICKUP		0.25 .. 35.00 A; ∞	∞ A	50N-3 Pickup
1318	50N-3 DELAY		0.00 .. 60.00 sec; ∞	0.05 sec	50N-3 Time Delay
1319A	50N-3 measurem.		Fundamental True RMS Instantaneous	Fundamental	50N-3 measurement of
1320A	50N-2 measurem.		Fundamental True RMS	Fundamental	50N-2 measurement of
1321A	50N-1 measurem.		Fundamental True RMS	Fundamental	50N-1 measurement of
1322A	51N measurem.		Fundamental True RMS	Fundamental	51N measurement of
2201	INRUSH REST.		OFF ON	OFF	Inrush Restraint
2202	2nd HARMONIC		10 .. 45 %	15 %	2nd. harmonic in % of fundamental
2203	CROSS BLOCK		NO YES	NO	Cross Block
2204	CROSS BLK TIMER		0.00 .. 180.00 sec	0.00 sec	Cross Block Time
2205	I Max	1A	0.30 .. 25.00 A	7.50 A	Maximum Current for Inrush Restraint
		5A	1.50 .. 125.00 A	37.50 A	

2.2.13 Information List

No.	Information	Type of Information	Comments
1704	>BLK 50/51	SP	>BLOCK 50/51
1714	>BLK 50N/51N	SP	>BLOCK 50N/51N
1718	>BLOCK 50-3	SP	>BLOCK 50-3
1719	>BLOCK 50N-3	SP	>BLOCK 50N-3
1721	>BLOCK 50-2	SP	>BLOCK 50-2
1722	>BLOCK 50-1	SP	>BLOCK 50-1
1723	>BLOCK 51	SP	>BLOCK 51
1724	>BLOCK 50N-2	SP	>BLOCK 50N-2
1725	>BLOCK 50N-1	SP	>BLOCK 50N-1
1726	>BLOCK 51N	SP	>BLOCK 51N
1751	50/51 PH OFF	OUT	50/51 O/C switched OFF
1752	50/51 PH BLK	OUT	50/51 O/C is BLOCKED
1753	50/51 PH ACT	OUT	50/51 O/C is ACTIVE
1756	50N/51N OFF	OUT	50N/51N is OFF
1757	50N/51N BLK	OUT	50N/51N is BLOCKED
1758	50N/51N ACT	OUT	50N/51N is ACTIVE

No.	Information	Type of Information	Comments
1761	50(N)/51(N) PU	OUT	50(N)/51(N) O/C PICKUP
1762	50/51 Ph A PU	OUT	50/51 Phase A picked up
1763	50/51 Ph B PU	OUT	50/51 Phase B picked up
1764	50/51 Ph C PU	OUT	50/51 Phase C picked up
1765	50N/51NPickedup	OUT	50N/51N picked up
1767	50-3 picked up	OUT	50-3 picked up
1768	50N-3 picked up	OUT	50N-3 picked up
1769	50-3 TRIP	OUT	50-3 TRIP
1770	50N-3 TRIP	OUT	50N-3 TRIP
1787	50-3 TimeOut	OUT	50-3 TimeOut
1788	50N-3 TimeOut	OUT	50N-3 TimeOut
1791	50(N)/51(N)TRIP	OUT	50(N)/51(N) TRIP
1800	50-2 picked up	OUT	50-2 picked up
1804	50-2 TimeOut	OUT	50-2 Time Out
1805	50-2 TRIP	OUT	50-2 TRIP
1810	50-1 picked up	OUT	50-1 picked up
1814	50-1 TimeOut	OUT	50-1 Time Out
1815	50-1 TRIP	OUT	50-1 TRIP
1820	51 picked up	OUT	51 picked up
1824	51 Time Out	OUT	51 Time Out
1825	51 TRIP	OUT	51 TRIP
1831	50N-2 picked up	OUT	50N-2 picked up
1832	50N-2 TimeOut	OUT	50N-2 Time Out
1833	50N-2 TRIP	OUT	50N-2 TRIP
1834	50N-1 picked up	OUT	50N-1 picked up
1835	50N-1 TimeOut	OUT	50N-1 Time Out
1836	50N-1 TRIP	OUT	50N-1 TRIP
1837	51N picked up	OUT	51N picked up
1838	51N TimeOut	OUT	51N Time Out
1839	51N TRIP	OUT	51N TRIP
1840	PhA InrushDet	OUT	Phase A inrush detection
1841	PhB InrushDet	OUT	Phase B inrush detection
1842	PhC InrushDet	OUT	Phase C inrush detection
1843	INRUSH X-BLK	OUT	Cross blk: PhX blocked PhY
1851	50-1 BLOCKED	OUT	50-1 BLOCKED
1852	50-2 BLOCKED	OUT	50-2 BLOCKED
1853	50N-1 BLOCKED	OUT	50N-1 BLOCKED
1854	50N-2 BLOCKED	OUT	50N-2 BLOCKED
1855	51 BLOCKED	OUT	51 BLOCKED
1856	51N BLOCKED	OUT	51N BLOCKED
1866	51 Disk Pickup	OUT	51 Disk emulation Pickup
1867	51N Disk Pickup	OUT	51N Disk emulation picked up
7551	50-1 InRushPU	OUT	50-1 InRush picked up
7552	50N-1 InRushPU	OUT	50N-1 InRush picked up
7553	51 InRushPU	OUT	51 InRush picked up
7554	51N InRushPU	OUT	51N InRush picked up

No.	Information	Type of Information	Comments
7556	InRush OFF	OUT	InRush OFF
7557	InRush BLK	OUT	InRush BLOCKED
7558	InRush Gnd Det	OUT	InRush Ground detected
7559	67-1 InRushPU	OUT	67-1 InRush picked up
7560	67N-1 InRushPU	OUT	67N-1 InRush picked up
7561	67-TOC InRushPU	OUT	67-TOC InRush picked up
7562	67N-TOC InRushPU	OUT	67N-TOC InRush picked up
7563	>BLOCK InRush	SP	>BLOCK InRush
7564	Gnd InRush PU	OUT	Ground InRush picked up
7565	Ia InRush PU	OUT	Phase A InRush picked up
7566	Ib InRush PU	OUT	Phase B InRush picked up
7567	Ic InRush PU	OUT	Phase C InRush picked up
10034	50-3 BLOCKED	OUT	50-3 BLOCKED
10035	50N-3 BLOCKED	OUT	50N-3 BLOCKED

2.3 Directional Overcurrent Protection 67, 67N

The directional time overcurrent protection comprises three elements each for phase currents and the ground current that can operate directional or non-directional. All elements are independent of each other and can be combined as desired.

High current element 67-2 and overcurrent element 67-1 always operate with a definite tripping time, the third element 67-TOC always operates with inverse tripping time.

Applications

- The directional overcurrent protection allows the application of multifunctional protection devices 7SJ80 also in systems where protection coordination depends on knowing both the magnitude of the fault current and the direction of power flow to the fault location.
- The non-directional overcurrent protection described in Section 2.2 may operate as overlapping backup protection or may be disabled. Additionally, individual elements (e.g. 67-2 and/or 67N-2) may be interconnected with the directional overcurrent protection.
- For parallel lines or transformers supplied from a single source, only directional overcurrent protection allows selective fault detection.
- For line sections supplied from two sources or in ring-operated lines, the overcurrent protection has to be supplemented by the element-specific directional criterion.

2.3.1 General

For parallel lines or transformers supplied from a single source (Figure 2-22), the second feeder (II) is opened on occurrence of a fault in the first feeder (I) if tripping of the breaker in the parallel feeder is not prevented by a directional measuring element (at B). Therefore, where indicated with an arrow (Figure 2-22), directional overcurrent protection is applied. Please ensure that the "forward" direction of the protection element is in the direction of the line (or object to be protected). This is not necessarily identical with the direction of the normal load flow, as shown in Figure 2-22.

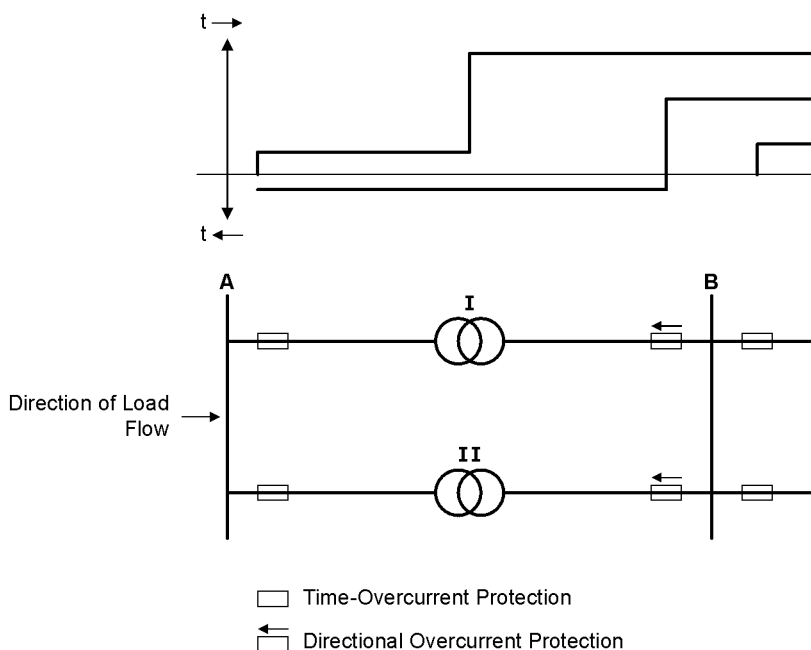

Figure 2-22 Overcurrent protection for parallel transformers

For line sections supplied from two sources or in ring-operated lines, the overcurrent protection has to be supplemented by the directional criterion. Figure 2-23 shows a ring system where both energy sources are merged to one single source.

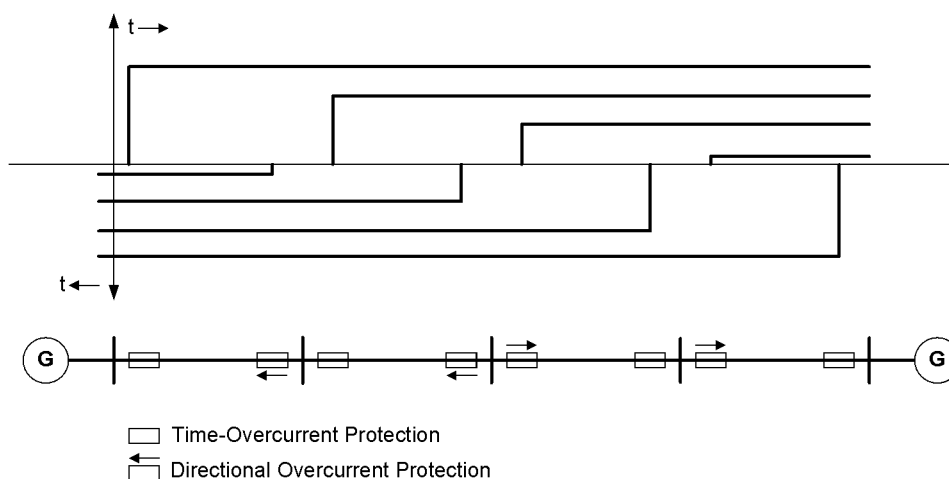

Figure 2-23 Transmission lines with sources at both ends

Depending on the setting of parameter 613 **Gnd O/Cprot. w.**, the ground current element can operate either with measured values I_N or with the values $3I_0$ calculated from the three phase currents. Devices featuring a sensitive ground current input, however, use the calculated quantity $3I_0$.

The directional orientation **Forward**, **Reverse** or **Non-Directional** can be set individually for each element (**Non-Directional** from V4.7 on).

For each element the time can be blocked via binary input or automatic reclosing (cycle-dependent), thus suppressing the trip command. Removal of blocking during pickup will restart time delays. The Manual Close signal is an exception. If a circuit breaker is manually closed onto a fault, it can be re-opened immediately. For over-

current elements or high-set elements the delay may be bypassed via a Manual Close pulse, thus resulting in high-speed tripping.

Furthermore, immediate tripping may be initiated in conjunction with the automatic reclosing function (cycle dependant).

Pickup stabilization for the 67/67N elements of the directional overcurrent protection can be accomplished by means of settable dropout times. This protection comes into use in systems where intermittent faults occur. Combined with electromechanical relays, it allows different dropout responses to be adjusted and a time grading of digital and electromechanical relays to be implemented.

Pickup and delay settings may be quickly adjusted to system requirements via dynamic setting switching (see Section 2.4).

Utilizing the inrush restraint feature tripping may be blocked by the 67-1, 67-TOC, 67N-1, and 67N-TOC elements in phases and ground path when inrush current is detected.

The following table gives an overview of the interconnections to other functions of the 7SJ80.

Table 2-6 Interconnection to other functions

Directional Time Overcurrent Protection Elements	Connection to Automatic Reclosing	Manual CLOSE	Dynamic Cold Load Pickup	Inrush Restraint
67-1	•	•	•	•
67-2	•	•	•	
67-3	•	•	•	
67-TOC	•	•	•	•
67N-1	•	•	•	•
67N-2	•	•	•	
67N-3	•	•	•	
67N-TOC	•	•	•	•

2.3.2 Definite Time, Directional High-set Elements 67-2, 67N-2

For each element an individual pickup value **67-2 PICKUP**, **67-3 PICKUP** or **67N-2 PICKUP**, **67N-3 PICKUP** is set which can be measured as *Fundamental* or *True RMS*. Each phase current and the ground current is compared with the common pickup value for each element **67-2 PICKUP**, **67-3 PICKUP** or **67N-2 PICKUP**, **67N-3 PICKUP**, and it is signaled when the value is exceeded provided that the fault direction is the same as the parameterized direction. After the associated delay times **67-2 DELAY**, **67-3 DELAY**, or **67N-2 DELAY**, **67N-3 DELAY** have expired, the tripping commands are initiated which are equally available separately for each element. The dropout value is approximately 95% of the pickup value for currents $> 0.3 I_{Nom}$.

Pickup can be stabilized by setting dropout times 1518 **67 T DROP-OUT** or 1618 **67N T DROP-OUT**. This time is started and maintains the pickup condition if the current falls below the threshold. Therefore, the function does not drop out instantaneously. The trip delay times **50-2 DELAY**, **67-3 DELAY** or **50N-2 DELAY**, **67N-3 DELAY** continue during that time. After the dropout delay time has elapsed, the pickup is reported OFF and the trip delay time is reset unless the threshold **50-2 PICKUP**, **67-3 PICKUP** or **50N-2 PICKUP**, **67N-3 PICKUP** has been exceeded again. If the threshold is exceeded again during the dropout delay time, the time is canceled. The trip delay time **50-2 DELAY**, **67-3 DELAY** or **50N-2 DELAY**, **67N-3 DELAY** continues. If the threshold value is exceeded after this time has elapsed, the trip command is issued immediately. If the threshold value is not exceeded at this time, there is no reaction. If the threshold value is exceeded again after expiry of the trip command delay time, while the dropout delay time is still running, tripping is initiated immediately.

Each of these elements can be directional or non-directional.

These elements can be blocked by the automatic reclosing function (79 AR).

The following figure gives an example of the logic diagram for the high-set elements 67-2 of the phase currents. The high-set element 67-3 is structured identically.

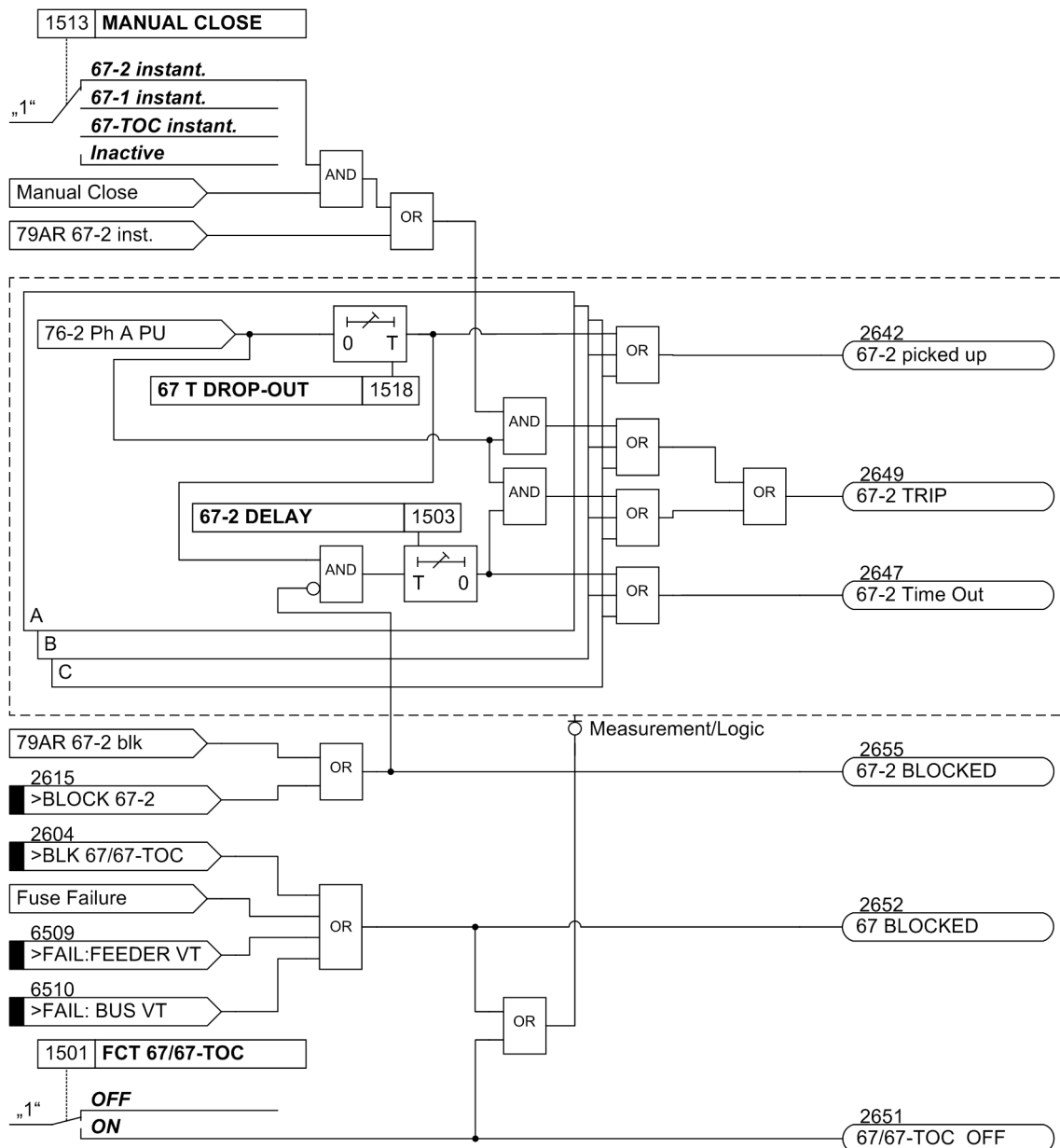

Figure 2-24 Logic diagram for directional high-set element 67-2 for phases

If parameter 1513 **MANUAL CLOSE** is set to **67-2 instant.** and manual close detection applies, the trip is initiated as soon as the pickup conditions arrive, even if the element is blocked via a binary input.

The same applies to 79 AR 67-2.

2.3.3 Directional Definite Time Overcurrent Elements 67-1, 67N-1

For each element, an individual pickup value **67-1 PICKUP** or **67N-1 PICKUP** is set which can be measured as *Fundamental* or *True RMS*. Phase and ground currents are compared separately with the common setting value **67-1 PICKUP** or **67N-1 PICKUP**. Currents above the setting values are recognized separately when fault direction is equal to the configured direction. If the inrush restraint function is used, either the normal pickup signals or the corresponding inrush signals are issued as long as inrush current is detected. When the relevant delay times **67-1 DELAY**, **67N-1 DELAY** have expired, a tripping command is issued unless an inrush has been recognized or inrush restraint is active. If the inrush restraint feature is enabled, and an inrush condition exists, no tripping takes place, but a message is recorded and displayed indicating when the overcurrent element time delay elapses. Trip signals and other flags for each element are issued when the element times out. The dropout value is roughly equal to 95% of the pickup value for currents $> 0.3 I_{Nom}$.

Pickup can be stabilized by setting dropout times **1518 67 T DROP-OUT** or **1618 67N T DROP-OUT**. This time is started and maintains the pickup condition if the current falls below the threshold. Therefore, the function does not drop out at high speed. The trip-command delay time **50-1 DELAY** or **50N-1 DELAY** continues in the meantime. After the dropout delay time has elapsed, the pickup is reported OFF and the trip delay time is reset unless the threshold **50-1 PICKUP** or **50N-1 PICKUP** has been exceeded again. If the threshold is exceeded again during the dropout delay time, the time is canceled. The trip-command delay time **50-1 DELAY** or **50N-1 DELAY** continues in the meantime. Should the threshold value be exceeded after its expiry, the trip command is issued immediately. If the threshold value is not exceeded at this time, there will be no reaction. If the threshold value is exceeded again after expiry of the trip-command delay time, while the dropout delay time is still running, tripping occurs immediately.

The inrush restraint of the overcurrent elements **50-1 PICKUP** or **50N-1 PICKUP** is disabled via configurable dropout times if an inrush pickup occurs, because the occurrence of an inrush does not constitute an intermittent fault.

Each of these elements can be directional or non-directional.

These elements can be blocked by the automatic reclosure function (AR).

The following figure shows by way of an example the logic diagram for the directional overcurrent element 67-1.

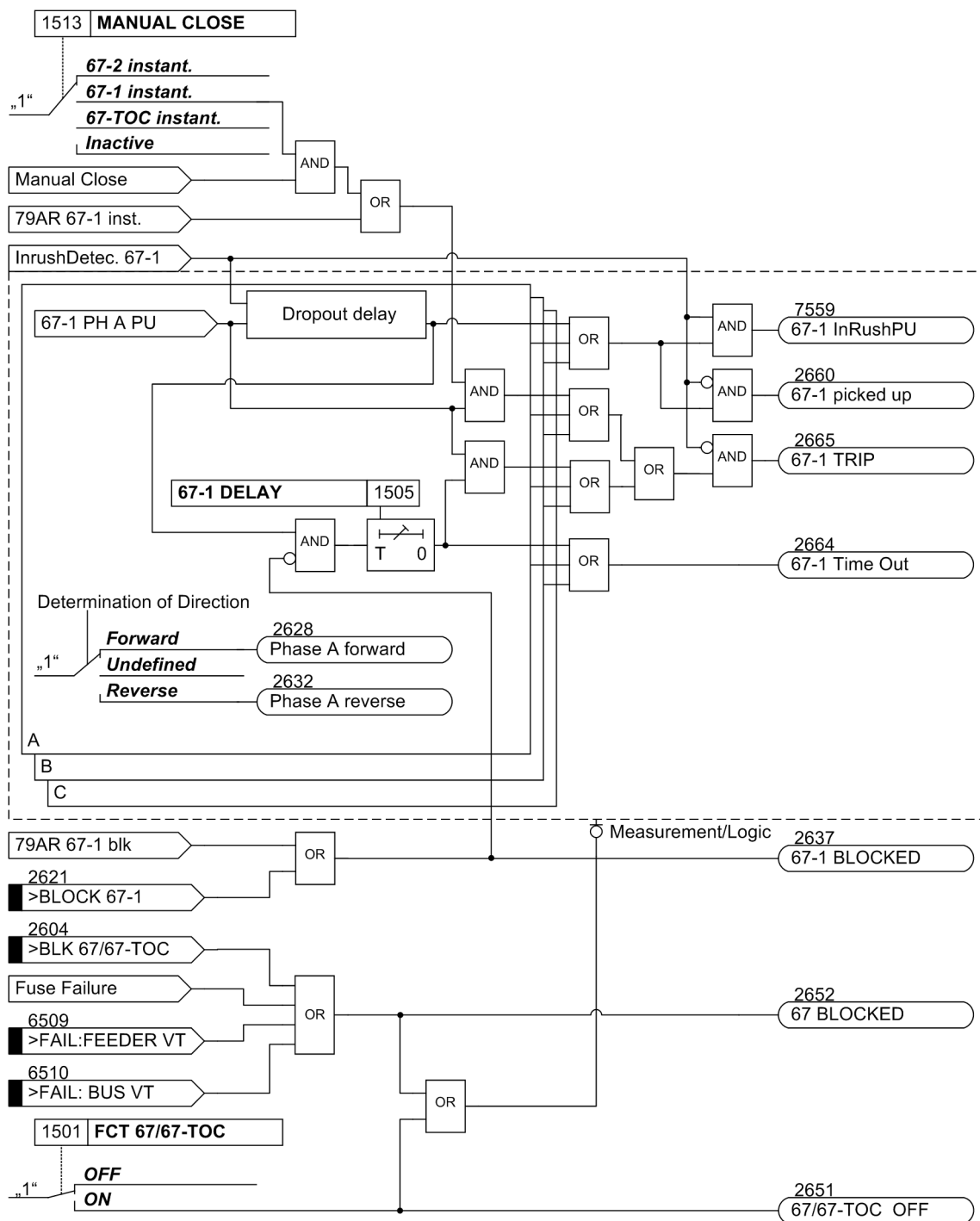

Figure 2-25 Logic diagram for the directional relay element 67-1 for phases

If parameter 1513 **MANUAL CLOSE** is set to **67-1 instant.** and manual close detection applies, the trip is initiated as soon as the pickup conditions arrive, even if the element is blocked via a binary input.

The same applies to 79 AR 67-1.

The dropout delay does only function if no inrush was detected. An approaching inrush resets an already running dropout time delay.

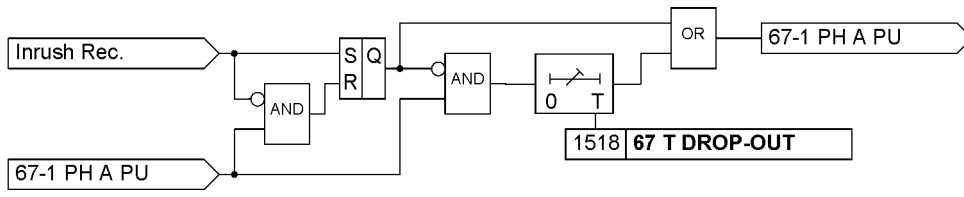

Figure 2-26 Logic of the dropout delay for 67-1

2.3.4 Inverse Time, Directional Overcurrent Elements 67-TOC, 67N-TOC

The inverse time elements are dependent on the device ordering version. They operate either according to IEC or ANSI-standard. The characteristics and associated formulae are identical to those of the non-directional overcurrent protection and are illustrated in the Section Technical Data. When the inverse time curves are configured, the definite time elements 67-2 and 67-1 are in effect.

Pickup Behavior

For each element, an individual pickup value **67-TOC PICKUP** or **67N-TOC PICKUP** is set which can be measured as *Fundamental* or *True RMS*. Each phase and ground current is separately compared with the common pickup value **67-TOC PICKUP** or **67N-TOC PICKUP** of each element. When a current value exceeds the corresponding setting value by a factor of 1.1, the corresponding phase picks up and a message is generated phase-selectively assuming that the fault direction is equal to the direction configured. If the inrush restraint feature is used, either the normal pickup signals or the corresponding inrush signals are issued as long as inrush current is detected. If the 67-TOC element picks up, the tripping time is calculated from the actual fault current flowing, using an integrating method of measurement. The calculated tripping time depends on the selected tripping curve. Once this time has elapsed, a trip signal is issued provided that no inrush current is detected or inrush restraint is disabled. If the inrush restraint feature is enabled and an inrush condition exists, no tripping takes place, but a message is recorded and displayed indicating when the overcurrent element time delay elapses.

For ground current element **67N-TOC**, the Curve may be selected independently of the Curve used for phase currents.

Pickup values of the 67-TOC (phases) and 67N-TOC (ground current) and the associated time multipliers may be set individually.

Each of these elements can work directionally or non-directionally.

Dropout Behaviour

When using an ANSI or IEC curve, it can be selected whether the dropout of an element is to occur instantaneously or whether dropout is to be performed by means of the disk emulation mechanism. "Instantaneously" means that pickup drops out when the pickup value of approx. 95 % of the set pickup value is undershot. For a new pickup, the time counter starts at zero.

The disk emulation evokes a dropout process (time counter is decrementing) which begins after de-energization. This process corresponds to the reset of a Ferraris disk (explaining its denomination "disk emulation"). In case several faults occur in succession the "history" is taken into consideration due to the inertia of the Ferraris disk and the time response is adapted. Reset begins as soon as 90 % of the setting value is undershot, in accordance to the dropout curve of the selected characteristic. In the range between the dropout value (95 % of the pickup value) and 90 % of the setting value, the incrementing and the decrementing processes are in idle state.

Disk emulation offers advantages when the overcurrent relay elements must be coordinated with conventional electromechanical overcurrent relays located towards the source.

The following figure shows by way of an example the logic diagram for the 67-TOC relay element of the directional inverse time overcurrent protection of the phase currents.

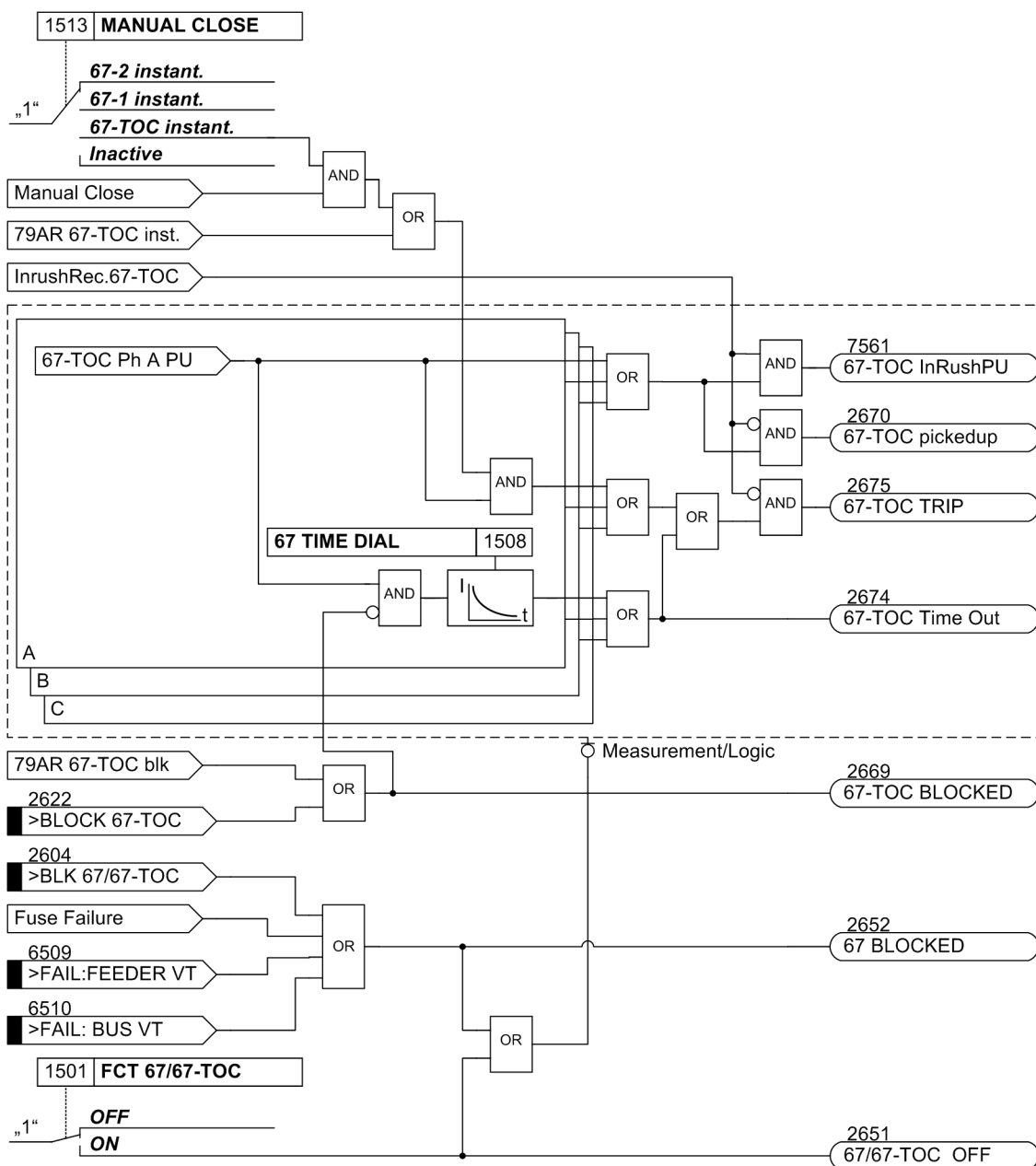

Figure 2-27 Logic diagram for the directional overcurrent protection: 67-TOC relay element

2.3.5 Interaction with the Fuse Failure Monitor (FFM)

False or undesired tripping can be caused by a measuring voltage that can be caused by either short-circuit or broken wire in the voltage transformer's secondary system or an operation of the voltage transformer fuse. Failure of the measuring voltage in one or two phases can be detected, and the directional time overcurrent elements (Dir Phase and Dir Ground) can be blocked, see logic diagrams. Undervoltage protection, sensitive ground fault detection and synchronization are also blocked in this case.

For additional information on the operation of the fuse failure monitor, see section 2.11.1 Measured Value Supervision.

2.3.6 Dynamic Cold Load Pickup

It may be necessary to dynamically increase the pickup values of the directional time overcurrent protection if, at starting, certain elements of the system show an increased power consumption after a long period of zero voltage (e.g. air-conditioning systems, heating installations, motors). Thus, a general raise of pickup thresholds can be avoided taking into consideration such starting conditions.

This dynamic cold load pickup function is common to all overcurrent elements and is described in Section 2.4. The alternative pickup values can be set individually for each element of the directional and non-directional time overcurrent protection.

2.3.7 Inrush Restraint

7SJ80 features an integrated inrush restraint function. It prevents "normal" pickup of the 67-1 or 67-TOC elements (not 67-2 and 67-3) in the phases and in the ground path of the non-directional and directional overcurrent protection functions. The same is true for the alternative pickup thresholds of the dynamic cold load pickup function. If inrush currents are detected, special inrush pickup signals are generated. These signals also initiate fault recording and start the associated trip delay time. If inrush conditions are still present after the tripping time delay has elapsed, a corresponding message ("...TimeOut ") is output, but tripping is blocked (for further information see "Inrush Restraint" in Section 2.2).

2.3.8 Determination of Direction

The determination of the fault direction for the phase directional element and the ground directional element is performed independently.

Basically, the direction determination is performed by determining the phase angle between the fault current and a reference voltage.

Method of Directional Measurement

For the phase directional element the fault current of the corresponding phase and the unfaulted phase-to-phase voltage are used as reference voltage. The unfaulted voltage also allows for a correct direction determination even if the fault voltage has collapsed entirely (short-line fault). In phase-to-Ground voltage connections, the phase-to-phase voltages are calculated. In a connection of two phase-to-phase voltages and V_N , the third phase-to-phase voltage is also calculated.

With three-phase short-line faults, memory voltage values are used to clearly determine the direction if the measurement voltages are not sufficient. Upon the expiration of the storage time period (2 s), the detected direction is saved, as long as no sufficient measuring voltage is available. When closing onto a fault, if no memory

voltage values exist in the buffer, the relay element will trip. In all other cases the voltage magnitude will be sufficient for determining the direction.

For each directional ground element there are two possibilities of direction determination:

Direction Determination with Zero-sequence System or Ground Quantities

For the directional ground fault elements, the direction can be determined from the zero-sequence system quantities. In the current path, the I_N current is valid, when the transformer neutral current is connected to the device. Otherwise, the device calculates the ground current from the sum of the three phase currents. In the voltage path, the displacement voltage V_N is used as reference voltage if connected. Otherwise the device calculates as reference voltage the zero-sequence voltage $3 \cdot V_0$ from the sum of the three phase voltages. If the magnitude of V_0 or $3 \cdot V_0$ is not sufficient to determine the direction, the direction is undefined. Then the directional ground element will not initiate a trip signal. The directional ground element cannot be applied when only two current transformers are used.

Direction Determination with Negative-sequence Quantities

Here, the negative sequence current and the negative sequence voltage as reference voltage are used to determine the direction. This is advantageous if the zero sequence is influenced via a parallel line or if the zero voltage becomes very small due to unfavorable zero sequence impedances. The negative sequence system is calculated from the individual voltages and currents. As with using the zero sequence quantities, the direction is only determined once the values required for direction determination have exceeded a certain minimum threshold. Otherwise, the direction will remain undetermined.

When voltage transformers are open delta-connected, direction determination is always based on the negative-sequence quantities.

Cross-Polarized Reference Voltages for Direction Determination

The direction of a phase-directional element is detected by means of a cross-polarized voltage. In a phase-to-Ground fault, the cross-polarized voltage (reference voltage) is 90° out of phase with the fault voltages (see Figure 2-28). With phase-to-phase faults, the position of the reference voltages changes, depending on the degree of collapse of the fault voltages, up to 30° .

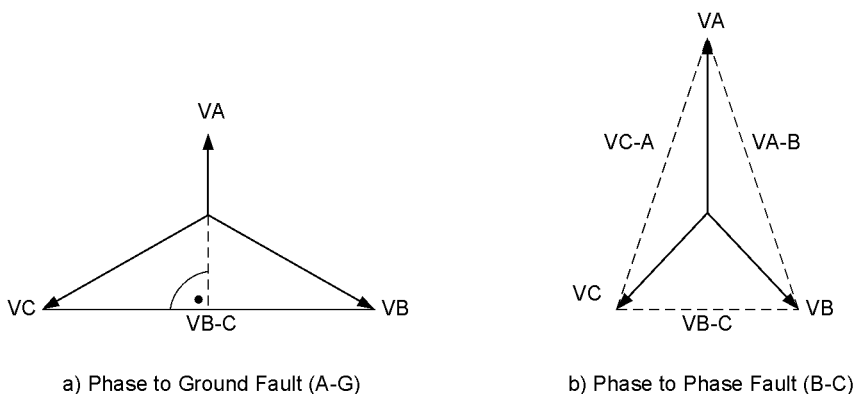

Figure 2-28 Cross-polarized voltages for direction determination

Measured Values for the Determination of Fault Direction

Each phase has its own phase measuring element. The fourth measuring element is used as ground measuring element. If the current exceeds the pickup threshold of a phase or that of the ground path, direction determination is started by the associated measuring element. In case of a multiphase fault, all phase measuring elements involved perform their own direction determination. If one of the calculated directions differs from the set direction, the function picks up.

The following table shows the allocation of measured values for the determination of fault direction for various causes of pickup.

Table 2-7 Measured Values for the Determination of Fault Direction

Pickup	Measuring element							
	A		B		C		Ground	
	Current	Voltage	Current	Voltage	Current	Voltage	Current	Voltage
A	I_A	$V_B - V_C$	—	—	—	—	—	—
B	—	—	I_B	$V_C - V_A$	—	—	—	—
C	—	—	—	—	I_C	$V_A - V_B$	—	—
N	—	—	—	—	—	—	I_N	$V_N^{1)}$
A, N	—	$V_B - V_C$	—	—	—	—	I_N	$V_N^{1)}$
B, N	—	—	I_B	$V_C - V_A$	—	—	I_N	$V_N^{1)}$
C, N	—	—	—	—	I_C	$V_A - V_B$	I_N	$V_N^{1)}$
A, B	I_A	$V_B - V_C$	I_B	$V_C - V_A$	—	—	—	—
B, C	—	—	I_B	$V_C - V_A$	I_C	$V_A - V_B$	—	—
AC	I_A	$V_B - V_C$	—	—	I_C	$V_A - V_B$	—	—
A, B, N	I_A	$V_B - V_C$	I_B	$V_C - V_A$	—	—	I_N	$V_N^{1)}$
B, C, N	—	—	I_B	$V_C - V_A$	I_C	$V_A - V_B$	I_N	$V_N^{1)}$
A, C, N	I_A	$V_B - V_C$	—	—	I_C	$V_A - V_B$	I_N	$V_N^{1)}$
A, B, C	I_A	$V_B - V_C$	I_B	$V_C - V_A$	I_C	$V_A - V_B$	—	—
A, B, C, N	I_A	$V_B - V_C$	I_B	$V_C - V_A$	I_C	$V_A - V_B$	I_N	$V_N^{1)}$

1) or $3 \cdot V_0 = |V_A + V_B + V_C|$, depending on the connection type of voltages

Direction Determination of Directional Phase Elements

As already mentioned, the direction determination is performed by determining the phase angle between the fault current and the reference voltage. In order to satisfy different network conditions and applications, the reference voltage can be rotated by an adjustable angle. In this way, the vector of the rotated reference voltage can be closely adjusted to the vector of the fault current in order to provide the best possible result for the direction determination. Figure 2-29 clearly shows the relationship for the directional phase element based on a single-phase ground fault in Phase A. The fault current I_{scA} follows the fault voltage by fault angle φ_{sc} . The reference voltage, in this case V_{BC} for the directional phase element A, is rotated by the setting value **ROTATION ANGLE**, positively counter-clockwise. In this case, a rotation by +45°.

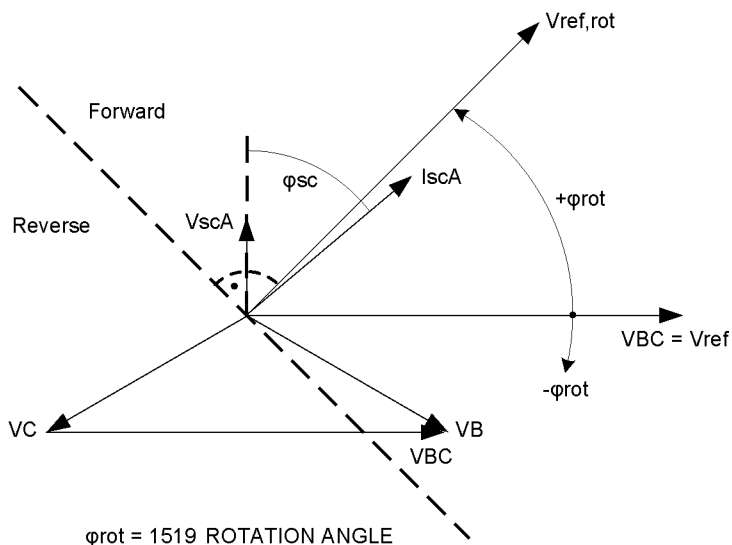

Figure 2-29 Rotation of the reference voltage, directional phase element

The rotated reference voltage defines the forward and reverse area, see Figure 2-30. The forward area is a range of $\pm 86^\circ$ around the rotated reference voltage $V_{ref,rot}$. If the vector of the fault current is in this area, the device detects forward direction. In the mirrored area, the device detects reverse direction. In the intermediate area, the direction result is undefined.

In a network, the vector of the fault current is usually in the forward or reverse area. If the vector moves out of one of these areas, e.g. the forward area, in direction of the undefined area, it leaves the forward area at $V_{ref,rot} \pm 86^\circ$ and reaches the undefined area. If the vector leaves the undefined area in direction of the forward area (or reverse area), a hysteresis of 2° is added. This hysteresis prevents chattering of the directional result. The current vector reaches the forward area at $\pm 84^\circ$ ($= 86^\circ - 2^\circ$ hysteresis).

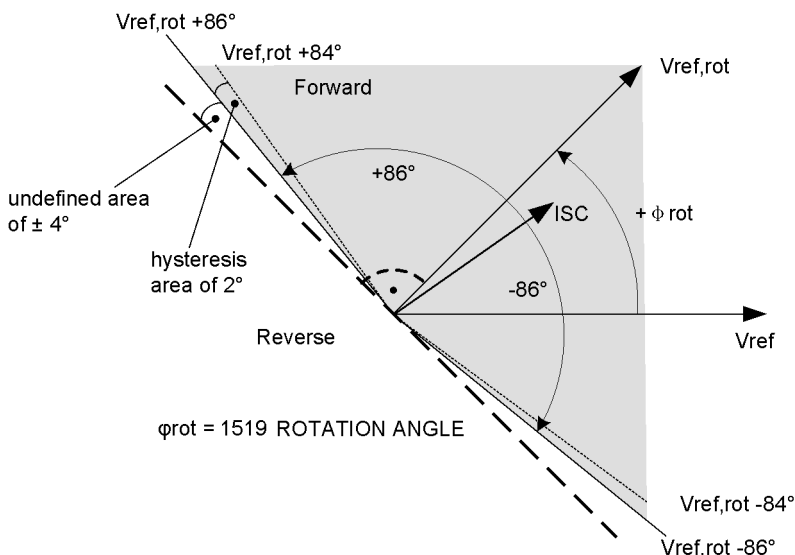

Figure 2-30 Forward characteristic of the directional function, directional phase element

Direction Determination of Directional Ground Element with Ground Values

Figure 2-31 shows the treatment of the reference voltage for the directional ground element, also based on a single-phase ground fault in phase A. Contrary to the directional phase elements, which work with the unfaulted voltage as reference voltage, the fault voltage itself is the reference voltage for the directional ground element. Depending on the connection of the voltage transformer, this is the voltage $3V_0$ (as shown in Figure 2-31) or V_N . The fault current $-3I_0$ is phase offset by 180° to the fault current I_{scA} and follows the fault voltage $3V_0$ by fault angle φ_{sc} . The reference voltage is rotated by the setting value 1619 **ROTATION ANGLE**. In this case, a rotation by -45° .

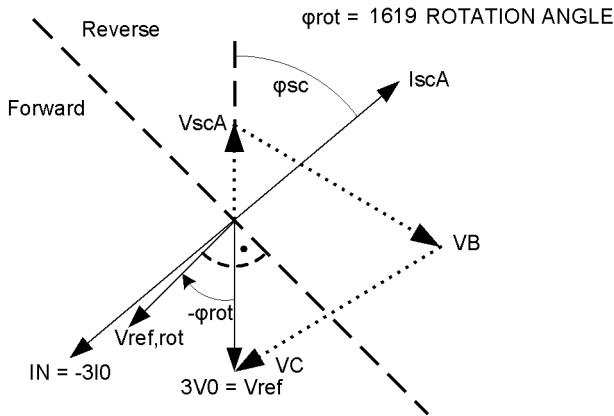

Figure 2-31 Rotation of the reference voltage, directional ground element with zero sequence values

The forward area is also a range of $\pm 86^\circ$ around the rotated reference voltage $V_{ref,rot}$. If the vector of the fault current $-3I_0$ (or I_N) is in this area, the device detects forward direction.

Direction Determination via Ground Element using Negative Sequence Values

Figure 2-32 shows the treatment of the reference voltage for the directional ground element using the negative sequence values based on a single-phase ground fault in phase A. As reference voltage, the negative sequence voltage is used, as current for the direction determination, the negative sequence system in which the fault current is displayed. The fault current $-3I_2$ is in phase opposition to the fault current I_{scA} and follows the voltage $3V_2$ by the fault angle φ_{sc} . The reference voltage is rotated through the setting value 1619 **ROTATION ANGLE**. In this case, a rotation of -45° .

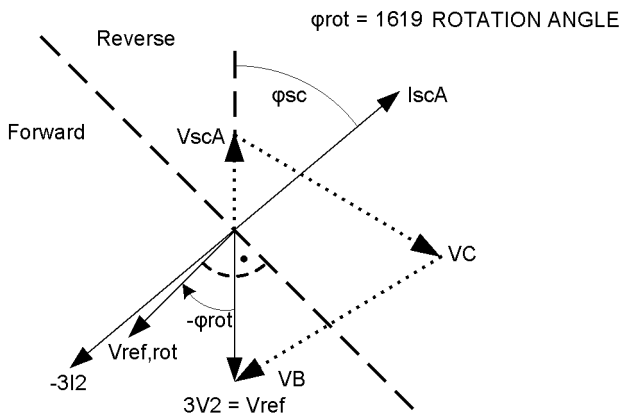

Figure 2-32 Rotation of the reference voltage, directional ground element with negative sequence values

The forward area is a range of $\pm 86^\circ$ around the rotated reference voltage $V_{ref, rot}$. If the vector of the negative sequence system current $-3I_2$ is in this area, the device detects forward direction.

2.3.9 Reverse Interlocking for Double End Fed Lines

Application Example

The directionality feature of the directional overcurrent protection enables the user to perform reverse interlocking also on double end fed lines using relay element 67-1. It is designed to selectively isolate a faulty line section (e.g. sections of rings) in high speed, i.e. no long graded times will slow down the process. This scheme is feasible when the distance between protective relays is not too great and when pilot wires are available for signal transfer via an auxiliary voltage loop.

For each line, a separate data transfer path is required to facilitate signal transmission in each direction. When implemented in a closed-circuit connection, disturbances in the communication line are detected and signalled with time delay. The local system requires a local interlocking bus wire similar to the one described in Subsection "Reverse Interlocking Bus Protection" for the directional overcurrent protection (Section 2.2).

During a line fault, the device that detects faults in forward (line) direction using the directional relay element 67-1 will block one of the non-directional overcurrent elements (50-1, 50-TOC) of devices in the reverse direction (at the same busbar) since they should not trip (Figure 2-33). In addition, a message is generated regarding the fault direction. "Forward" messages are issued when the current threshold of the directional relay element 67-1 is exceeded and directional determination is done. Subsequently, "forward" messages are transmitted to the device located in reverse direction.

During a busbar fault, the device that detects faults in reverse (busbar) direction using the directional relay element 67-1 will block one of the non-directional overcurrent elements (50-1, 50-TOC) of devices at the opposite end of the same feeder. In addition, a "Reverse" message is generated and transmitted via the auxiliary voltage loop to the relay located at the opposite end of the line.

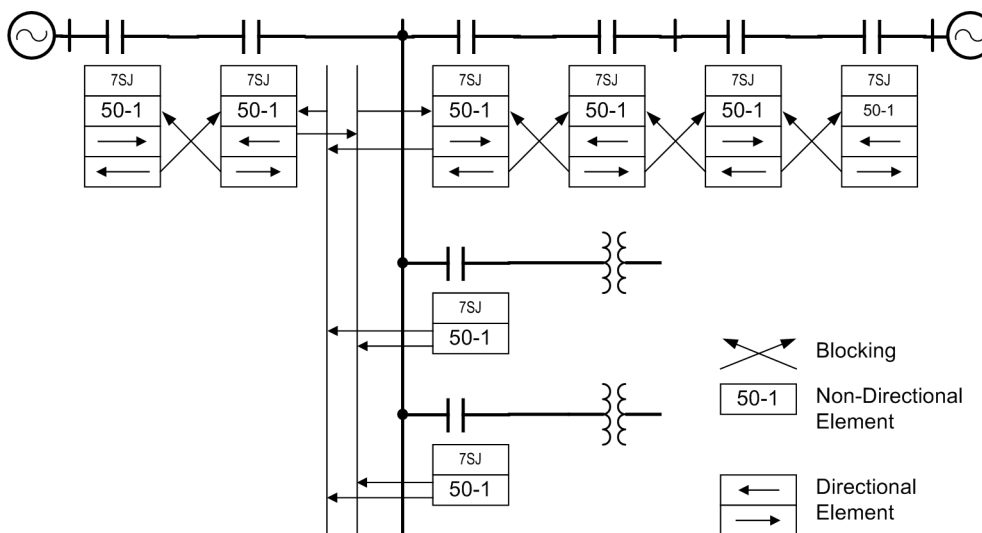

Figure 2-33 Reverse interlocking using directional elements

The directional overcurrent element providing normal time grading operates as selective backup protection.

The following figure shows the logic diagram for the generation of fault direction signals.

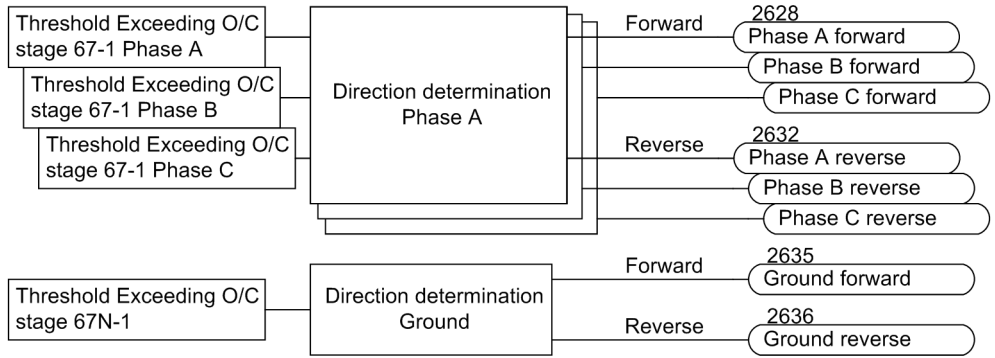

Figure 2-34 Logic diagram for the generation of fault direction signals

2.3.10 Setting Notes

General

When selecting the directional time overcurrent protection in DIGSI, a dialog box appears with several tabs for setting the associated parameters. Depending on the functional scope specified during configuration of the protective functions in addresses 115 **67/67-TOC** and 116 **67N/67N-TOC**, the number of tabs can vary.

If **67/67-TOC** or **67N/67N-TOC** is set equal to **Definite Time**, only the parameters for definite time overcurrent protection are accessible here. If you select **TOC IEC** or **TOC ANSI**, the inverse time characteristics is available, too. The superimposed directional elements 67-3, 67-2 and 67-1 or 67N-3, 67N-2 and 67N-1 apply in all these cases.

At address 1501 **FCT 67/67-TOC**, directional phase overcurrent protection may be switched **ON** or **OFF**.

Pickup values, time delays, and Curve are set separately for phase protection and ground protection. Because of this, relay coordination for ground faults is independent of relay coordination for phase faults, and more sensitive settings can often be applied to directional ground protection. Thus, at address 1601 **FCT 67N/67N-TOC**, directional ground time overcurrent protection may be switched **ON** or **OFF** independent of the directional phase time overcurrent protection.

Depending on the parameter 613 **Gnd 0/Cprot. w.**, the device can either operate using measured values I_N or the quantities $3I_0$ calculated from the three phase currents. Devices featuring a sensitive ground current input generally use the calculated quantity $3I_0$.

The directional orientation of the function is influenced by parameter 201 **CT Starpoint** (see Chapter 2.1.3).

Measurement Methods

The comparison values to be used for the respective element can be set in the setting sheets for the elements.

- Measurement of the **Fundamental Harmonic** (standard method):
This measurement method processes the sampled values of the current and filters in numerical order the fundamental harmonic so that the higher harmonics or transient peak currents are rejected.
- Measurement of the **True RMS Value**
The current amplitude is derived from the sampled value in accordance with the definition equation of the true RMS value. This measurement method should be selected when higher harmonics are to be considered by the function (e.g. in capacitor bank).

The type of the comparison values can be set under the following addresses:

67-3 Element	Address 1527 67 -3 MEASUREM .
67-2 Element	Address 1520 67 -2 MEASUREM .
67-1 Element	Address 1521 67 -1 MEASUREM .
67-TOC Element	Address 1522 67 -TOC MEASUR .
67N-3 Element	Address 1627 67N-3 MEASUREM .
67N-2 Element	Address 1620 67N-2 MEASUREM .
67N-1 Element	Address 1621 67N-1 MEASUREM .
67N-TOC Element	Address 1622 67N -TOC MEASUR .

Directional Characteristic

The direction characteristic, i.e. the position of the ranges „forward“ and „reverse“ is set for the phase directional elements under address 1519 **ROTATION ANGLE** and for the ground directional element under address 1619 **ROTATION ANGLE**. The short-circuit angle is generally inductive in a range of 30° to 60°. This means that usually the default settings of +45° for the phase directional elements and -45° for the ground directional element can be maintained for the adjustment of the reference voltage, as they guarantee a safe direction result.

Nevertheless, the following contains some setting examples for special applications (Table 2-8). The following must be observed: With the phase directional elements, the reference voltage (fault-free voltage) for phase-Ground-faults is vertical on the short-circuit voltage. For this reason, the resulting setting of the angle of rotation is (see also Section 2.3.8):

$$\text{Ref. volt. angle of rotation} = 90 - \varphi_k \quad \text{Phase directional element (phase-to-ground fault).}$$

With the ground directional element, the reference voltage is the short-circuit voltage itself. The resulting setting of the angle of rotation is then:

$$\text{Ref. volt. angle of rotation} = -\varphi_k \quad \text{Directional ground element (phase-to-ground fault).}$$

It should also be noted for phase directional elements that with phase-to-phase faults, the reference voltage is rotated between 0° (remote fault) and 30° (close-up fault) depending on the collapse of the faulty voltage. This can be taken into account with a mean value of 15°:

$$\text{Ref. volt. angle of rotation} = 90 - \varphi_k - 15^\circ \quad \text{Phase directional element (phase-to-phase fault).}$$

Table 2-8 Setting examples

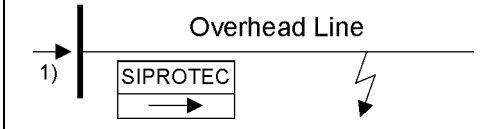
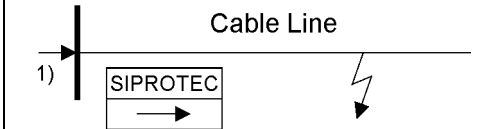
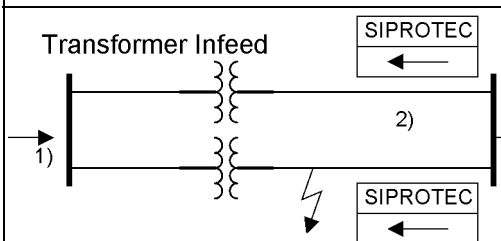
Application	φ_{sc} typical	Setting Directional Phase Element 1519 ROTATION ANGLE	Setting Directional Ground Element 1619 ROTATION ANGLE
 <p>Overhead Line</p>	60°	Range 30°..0.0° → 15°	-60°
 <p>Cable Line</p>	30°	Range 60°...30° → 45°	-30°
 <p>Transformer Infeed</p>	30°	Range 60°...30° → 45°	-30°

- 1) Power flow direction
- 2) With the assumption that these are cable lines

Directional Orientation

The directional orientation **Forward** or **Reverse** can be set separately for each element. Moreover, each element can also be operated **Non-Directional**.

- Address 1526 **67-3 Direction**
- Address 1523 **67-2 Direction**
- Address 1524 **67-1 Direction**
- Address 1525 **67-T0C Direct.**
- Address 1626 **67N-3 Direction**
- Address 1623 **67N-2 Direction**
- Address 1624 **67N-1 Direction**
- Address 1625 **67N-T0C Direct.**



Note

If the threshold value of the 67-1 or 67N-1 Element is exceeded, the phase-specific directional indications „forward“ or „reverse“ are output (indications 2628 to 2636), independent of whether the fault direction is the same as the configured direction.

These indications are used for directional comparison protection.

Selection of the variables for the direction determination for the ground directional element

Parameter 1617 **67N POLARIZAT.** can be set to specify whether direction determination is accomplished from the zero sequence quantities or ground quantities (*with VN and IN*) or from the negative sequence quantities (*with V2 and I2*) in the ground directional element. The first option is the preferential setting; the latter is to be selected in case of danger that the zero voltage be too small due to unfavourable zero impedance or that a parallel line influences the zero system.



Note

If parameter 213 **VT Connect. 3ph** is set to **Vab, Vbc** or **Vab, Vbc, VSyn** or **Vab, Vbc, Vx**, the direction is always determined using the negative sequence values V2/I2. For these voltage connection types the zero sequence voltage (VN or 3V0) is not available.

Directional High-set Elements 67-2, 67-3 (phases)

The high-current element **67-2 PICKUP** or **67-3 PICKUP** is set at address 1502 or 1528. The associated delay **67-2 DELAY** or **67-3 DELAY** at 1503 or 1529. For setting, the same considerations apply as did for the non-directional time overcurrent protection in Section 2.2.11.

The selected time is only an additional time delay and does not include the operating time (measuring time, dropout time). The delay can be set to ∞ . After pickup the Element will then not trip. Pickup, however, will be signaled. If the 67-2 Element or 67-3 Element is not required at all, the pickup value **67-2 PICKUP** or **67-3 PICKUP** should be set to ∞ . For this setting, there is neither a pickup signal generated nor a trip.

Directional High-set Elements 67-2, 67-3 (Ground)

The high-current element **67N-2 PICKUP** or **67N-3 PICKUP** is set at address 1602 or 1628. The associated delay **67N-2 DELAY** or **67N-3 DELAY** at 1603 or 1629. The same considerations apply for these settings as for the phase currents.

The selected time is an additional delay time and does not include the operating time (measuring time, dropout time). If the delay time is set to ∞ , the Element does not trip after the pickup, but the pickup condition is signaled. If the directional 67N-2 or 67N-3 Element or Element is not required, set the pickup threshold **67N-2 PICKUP** or **67N-3 PICKUP** to ∞ . This setting prevents tripping and the generation of a pickup indication.

Directional Overcurrent Element 67-1 (phases)

The pickup value of the 67-1 element (**67-1 PICKUP**) address 1504 should be set above the maximum anticipated load current. Pickup due to overload should never occur since in this mode the device operates as fault protection with correspondingly short tripping times and not as overload protection. For this reason, lines are set to approx. 20% above the maximum expected (over)load and transformers and motors to approx. 40%.

If the relay is used to protect transformers or motors with large inrush currents, the inrush restraint feature of 7SJ80 may be used for the **67-1** relay element (for more information see margin heading "Inrush Restraint").

The delay for directional Elements (address 1505 **67-1 DELAY**) is usually set shorter than the delay for non-directional Elements (address 1205) since the non-directional Elements overlap the directional elements as backup protection. It should be based on the system coordination requirements for directional tripping.

For parallel transformers supplied from a single source (see "Applications"), the delay of element **67-1 DELAY** located on the load side of the transformers may be set to 0 without provoking negative impacts on selectivity.

The selected time is only an additional time delay and does not include the operating time (measuring time, dropout time). The delay can be set to ∞ . After pickup the Element will then not trip. Pickup, however, will be signaled. If the 67-1 Element is not required at all, the pickup value **67-1 PICKUP** should be set to ∞ . This setting prevents from tripping and the generation of a pickup message.

Directional Overcurrent Element 67N-1 (Ground)

The pickup value of the **67N-1** overcurrent element should be set below the minimum anticipated ground fault current.

If the relay is used to protect transformers or motors with large inrush currents, the inrush restraint feature of 7SJ80 may be used for the **67N-1** relay element (for more information see margin heading "Inrush Restraint").

The delay is set at address 1605 **67N-1 DELAY** and should be based on system coordination requirements for directional tripping. For ground currents in a grounded system a separate coordination chart with short time delay is often used.

The selected time is only an additional time delay and does not include the operating time (measuring time, dropout time). The delay can be set to ∞ . After pickup the Element will then not trip. Pickup, however, will be signaled. If the 67N-1 Element is not required at all, the pickup value **67N-1 PICKUP** should be set to ∞ . This setting prevents from tripping and the generation of a pickup message.

Pickup Stabilization (67/67N Directional)

The pickups can also be stabilized via parameterizable dropout times under address 1518 **67 T DROP-OUT** or 1618 **67N T DROP-OUT**.

Directional Element 67-TOC with IEC or ANSI Curves (phases)

Having set address 115 **67/67-TOC = TOC IEC** or **TOC ANSI** when configuring the protection functions (Section 2.1.1), the parameters for the inverse time characteristics will also be available.

If the relay is used to protect transformers or motors with large inrush currents, the inrush restraint function of 7SJ80 may be used for the **67-TOC** relay element (for more information see margin heading "Inrush Restraint").

If the inverse time trip characteristic is selected, it must be noted that a safety factor of about 1.1 has already been included between the pickup value and the setting value. This means that a pickup will only occur if a current of about 1.1 times the setting value is present.

The current value is set in address 1507 **67-TOC PICKUP**. The setting is mainly determined by the maximum operating current. Pickup due to overload should never occur, since the device in this operating mode operates as fault protection with correspondingly short tripping times and not as overload protection.

The corresponding element time multiplication factor for an IEC Curve is set at address 1508 **67 TIME DIAL** and in address 1509 **67 TIME DIAL** for an ANSI Curve. It must be coordinated with the time grading of the network.

The time multiplier can also be set to ∞ . After pickup the Element will then not trip. Pickup, however, will be signaled. If the 67-TOC Element is not required at all, address 115 **67/67-TOC** should be set to **Definite Time** during protective function configuration (see Section 2.1.1).

If address 115 **67/67-TOC = TOC IEC**, you can specify the desired IEC-Curve (**Normal Inverse**, **Very Inverse**, **Extremely Inv.** or **Long Inverse**) in address 1511 **67- IEC CURVE**. If address 115 **67/67-TOC = TOC ANSI** you can specify the desired ANSI-Curve (**Very Inverse**, **Inverse**, **Short Inverse**, **Long Inverse**, **Moderately Inv.**, **Extremely Inv.** or **Definite Inv.**) in address 1512 **67- ANSI CURVE**.

Directional Element 67N-TOC with IEC or ANSI Curves (Ground)

Having set address 116 **67N/67N-TOC = TOC IEC** when configuring the protection functions (Section 2.1.1), the parameters for the inverse time characteristics will also be available. Specify in address 1611 **67N-TOC IEC** the desired IEC Curve (**Normal Inverse**, **Very Inverse**, **Extremely Inv.** or **Long Inverse**). If address 116 **67N/67N-TOC** was set to **TOC ANSI**, you can select the desired ANSI Curve (**Very Inverse**, **Inverse**, **Short Inverse**, **Long Inverse**, **Moderately Inv.**, **Extremely Inv.** or **Definite Inv.**) in address 1612 **67N-TOC ANSI**.

If the relay is used to protect transformers or motors with large inrush currents, the inrush restraint feature of 7SJ80 may be used for the **67N-TOC** relay element (for more information see margin heading "Inrush Restraint").

If the inverse time trip characteristic is selected, it must be noted that a safety factor of about 1.1 has already been included between the pickup value and the setting value **67N-TOC PICKUP**. This means that a pickup will only occur if a current of about 1.1 times the setting value is present. If **Disk Emulation** was selected at address 1610 **67N-TOC DropOut**, reset will occur in accordance with the reset curve as for the existing non-directional time overcurrent protection described in Section 2.2.

The current value is set at address 1607 **67N-TOC PICKUP**. The minimum appearing ground fault current is most relevant for this setting.

The corresponding element time multiplication factor for an IEC Curve is set at address 1608 **67N-TOC T-DIAL** and in address 1609 **67N-TOC T-DIAL** for an ANSI Curve. This has to be coordinated with the system grading coordination chart for directional tripping. For ground currents with grounded network, you can mostly set up a separate grading coordination chart with shorter delay times.

The time multiplier can also be set to ∞ . After pickup the Element will then not trip. Pickup, however, will be signaled. If the 67N-TOC Element is not required at all, address 116 **67N/67N-TOC** should be set to **Definite Time** during protection function configuration (see Section 2.1.1).

Inrush Restraint

When applying the protection device to transformers where high inrush currents are to be expected, the 7SJ80 can make use of an inrush restraint function for the directional overcurrent elements **67-1**, **67-TOC**, **67N-1** and **67N-TOC** as well as the non-directional overcurrent elements. The inrush restraint option is enabled or disabled in 2201 **INRUSH REST**. (in the settings option **non-directional** time overcurrent protection). The characteristic values of the inrush restraint are already listed in the section discussing the non-directional time overcurrent (Section 2.2.11).

Manual Close Mode (phases, Ground)

When a circuit breaker is closed onto a faulted line, a high speed trip by the circuit breaker is often desired. For overcurrent or high-set Element the delay may be bypassed via a Manual Close pulse, thus resulting in instantaneous tripping. This pulse is prolonged by at least 300 ms. To enable the device to react properly on occurrence of a fault in the phase elements after manual close, address 1513 **MANUAL CLOSE** has to be set accordingly. Accordingly, address 1613 **MANUAL CLOSE** is considered for the ground path address. Thus, the user determines for both elements, the phase and the Ground element, what pickup value is active with what delay when the circuit breaker is closed manually.

External Control Switch

If the manual closing signal is not generated by the 7SJ80, that is, it is sent neither via the built-in operator interface nor via the serial port but directly from a control acknowledgment switch, this signal must be passed to a 7SJ80 binary input, and configured accordingly („>Manual Close“) so that the Element selected for **MANUAL CLOSE** will be effective. **Inactive** means that all Element operate with the configured tripping times even with manual close.

Internal Control Function

The manual closing information must be allocated via CFC (interlocking task-level) using the CMD_Information block, if the internal control function is used.

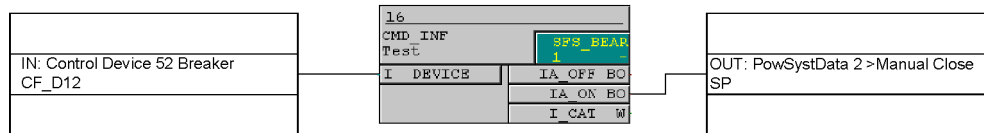

Figure 2-35 Example for the generation of a manual close signal using the internal control function



Note

For an interaction between the automatic reclosing function (79 AR) and the control function, an extended CFC logic is necessary. See margin heading „Close command: Directly or via Control“ in the Setting Notes of the automatic reclosing function (Section 2.15.6).

Interaction with Automatic Reclosure Function (phases)

When reclosing follows, high-speed protection against faults with 67-2 or 67-3 is usually desired. If the fault still exists after reclosing, the 67-1 or 67-TOC element will be initiated with graded tripping times, that is, the 67-2 or 67-3 element will be blocked. You can use parameter 1514 **67-2 active** or 1532 **67-3 active** to define whether the 67-2 or 67-3 element is influenced by a release signal of the internal or an external automatic reclosing device or not. The setting **with 79 active** means that the 67-2 or 67-3 element is only released if the automatic reclosing function is not blocked. If this is not desired, the setting **always** is selected so that the 67-2 or 67-3 element is always active as configured.

The integrated automatic reclosing function of 7SJ80 also provides the option to individually determine for each overcurrent element whether tripping or blocking is to be carried out instantaneously, unaffected by the AR with time delay (see Section 2.15).

Interaction with Automatic Reclosing Function (Ground)

If reclosing follows, high-speed and simultaneous closing in the event of a fault with 67N-2 is usually desired. If the fault still exists after reclosing, the 67N-1 or 67N-TOC element is initiated with graded tripping times, that is, the 67N-2 or 67N-3 element is blocked. For this purpose, parameter 1614 **67N-2 active** or 1632 **67N-3 active** is used to determine whether the 67N-2 or 67N-3 element is influenced by the release signal of the internal or an external automatic reclosing device or not. The setting **with 79 active** means that the 67N-2 or 67N-3 element is only released if the automatic reclosing function is not blocked. If this is not desired, the setting **always** is selected so that the 67N-2 or 67N-3 element is always active as configured.

The integrated automatic reclosing function of 7SJ80 also provides the option to individually determine for each overcurrent element whether tripping or blocking is to be carried out instantaneously, unaffected by the AR with time delay (see Section 2.15).

2.3.11 Settings

Addresses which have an appended "A" can only be changed with DIGSI, under "Display Additional Settings".

The table indicates region-specific default settings. Column C (configuration) indicates the corresponding secondary nominal current of the current transformer.

Addr.	Parameter	C	Setting Options	Default Setting	Comments
1501	FCT 67/67-TOC		OFF ON	OFF	67, 67-TOC Phase Time Overcurrent
1502	67-2 PICKUP	1A	0.10 .. 35.00 A; ∞	2.00 A	67-2 Pickup
		5A	0.50 .. 175.00 A; ∞	10.00 A	
1503	67-2 DELAY		0.00 .. 60.00 sec; ∞	0.10 sec	67-2 Time Delay
1504	67-1 PICKUP	1A	0.10 .. 35.00 A; ∞	1.00 A	67-1 Pickup
		5A	0.50 .. 175.00 A; ∞	5.00 A	
1505	67-1 DELAY		0.00 .. 60.00 sec; ∞	0.50 sec	67-1 Time Delay
1507	67-TOC PICKUP	1A	0.10 .. 4.00 A	1.00 A	67-TOC Pickup
		5A	0.50 .. 20.00 A	5.00 A	
1508	67 TIME DIAL		0.05 .. 3.20 sec; ∞	0.50 sec	67-TOC Time Dial
1509	67 TIME DIAL		0.50 .. 15.00 ; ∞	5.00	67-TOC Time Dial
1510	67-TOC Drop-out		Instantaneous Disk Emulation	Disk Emulation	Drop-Out Characteristic
1511	67- IEC CURVE		Normal Inverse Very Inverse Extremely Inv. Long Inverse	Normal Inverse	IEC Curve
1512	67- ANSI CURVE		Very Inverse Inverse Short Inverse Long Inverse Moderately Inv. Extremely Inv. Definite Inv.	Very Inverse	ANSI Curve
1513A	MANUAL CLOSE		67-3 instant. 67-2 instant. 67-1 instant. 67-TOC instant. Inactive	67-2 instant.	Manual Close Mode
1514A	67-2 active		with 79 active always	always	67-2 active
1518A	67 T DROP-OUT		0.00 .. 60.00 sec	0.00 sec	67 Drop-Out Time Delay
1519A	ROTATION ANGLE		-180 .. 180 °	45 °	Rotation Angle of Reference Voltage
1520A	67-2 MEASUREMENT.		Fundamental True RMS	Fundamental	67-2 measurement of
1521A	67-1 MEASUREMENT.		Fundamental True RMS	Fundamental	67-1 measurement of

Addr.	Parameter	C	Setting Options	Default Setting	Comments
1522A	67-TOC MEASUR.		Fundamental True RMS	Fundamental	67-TOC measurement of
1523	67-2 Direction		Forward Reverse Non-Directional	Forward	67-2 Direction
1524	67-1 Direction		Forward Reverse Non-Directional	Forward	67-1 Direction
1525	67-TOC Direct.		Forward Reverse Non-Directional	Forward	67-TOC Direction
1526	67-3 Direction		Forward Reverse Non-Directional	Forward	67-3 Direction
1527A	67-3 MEASUREM.		Fundamental True RMS	Fundamental	67-3 measurement of
1528	67-3 PICKUP	1A	1.00 .. 35.00 A; ∞	∞ A	67-3 Pickup
		5A	5.00 .. 175.00 A; ∞	∞ A	
1529	67-3 DELAY		0.00 .. 60.00 sec; ∞	0.00 sec	67-3 Time Delay
1532A	67-3 active		always with 79 active	always	67-3 active
1601	FCT 67N/67N-TOC		OFF ON	OFF	67N, 67N-TOC Ground Time Overcurrent
1602	67N-2 PICKUP	1A	0.05 .. 35.00 A; ∞	0.50 A	67N-2 Pickup
		5A	0.25 .. 175.00 A; ∞	2.50 A	
1603	67N-2 DELAY		0.00 .. 60.00 sec; ∞	0.10 sec	67N-2 Time Delay
1604	67N-1 PICKUP	1A	0.05 .. 35.00 A; ∞	0.20 A	67N-1 Pickup
		5A	0.25 .. 175.00 A; ∞	1.00 A	
1605	67N-1 DELAY		0.00 .. 60.00 sec; ∞	0.50 sec	67N-1 Time Delay
1607	67N-TOC PICKUP	1A	0.05 .. 4.00 A	0.20 A	67N-TOC Pickup
		5A	0.25 .. 20.00 A	1.00 A	
1608	67N-TOC T-DIAL		0.05 .. 3.20 sec; ∞	0.20 sec	67N-TOC Time Dial
1609	67N-TOC T-DIAL		0.50 .. 15.00 ; ∞	5.00	67N-TOC Time Dial
1610	67N-TOC DropOut		Instantaneous Disk Emulation	Disk Emulation	Drop-Out Characteristic
1611	67N-TOC IEC		Normal Inverse Very Inverse Extremely Inv. Long Inverse	Normal Inverse	IEC Curve
1612	67N-TOC ANSI		Very Inverse Inverse Short Inverse Long Inverse Moderately Inv. Extremely Inv. Definite Inv.	Very Inverse	ANSI Curve

Addr.	Parameter	C	Setting Options	Default Setting	Comments
1613A	MANUAL CLOSE		67N-3 instant. 67N-2 instant. 67N-1 instant. 67N-TOC instant Inactive	67N-2 instant.	Manual Close Mode
1614A	67N-2 active		always with 79 active	always	67N-2 active
1617	67N POLARIZAT.		with VN and IN with V2 and I2	with VN and IN	Ground Polarization
1618A	67N T DROP-OUT		0.00 .. 60.00 sec	0.00 sec	67N Drop-Out Time Delay
1619A	ROTATION ANGLE		-180 .. 180 °	-45 °	Rotation Angle of Reference Voltage
1620A	67N-2 MEASUREM.		Fundamental True RMS	Fundamental	67N-2 measurement of
1621A	67N-1 MEASUREM.		Fundamental True RMS	Fundamental	67N-1 measurement of
1622A	67N-TOC MEASUR.		Fundamental True RMS	Fundamental	67N-TOC measurement of
1623	67N-2 Direction		Forward Reverse Non-Directional	Forward	67N-2 Direction
1624	67N-1 Direction		Forward Reverse Non-Directional	Forward	67N-1 Direction
1625	67N-TOC Direct.		Forward Reverse Non-Directional	Forward	67N-TOC Direction
1626	67N-3 Direction		Forward Reverse Non-Directional	Forward	67N-3 Direction
1627A	67N-3 MEASUREM.		Fundamental True RMS	Fundamental	67N-3 measurement of
1628	67N-3 PICKUP		0.50 .. 35.00 A; ∞	∞ A	67N-3 Pickup
1629	67N-3 DELAY		0.00 .. 60.00 sec; ∞	0.00 sec	67N-3 Time Delay
1632A	67N-3 active		always with 79 active	always	67N-3 active

2.3.12 Information List

No.	Information	Type of Information	Comments
2603	67N-3 TRIP	OUT	67N-3 TRIP
2604	>BLK 67/67-TOC	SP	>BLOCK 67/67-TOC
2605	67N-3 BLOCKED	OUT	67N-3 is BLOCKED
2606	67-3 BLOCKED	OUT	67-3 is BLOCKED
2614	>BLK 67N/67NTOC	SP	>BLOCK 67N/67N-TOC
2615	>BLOCK 67-2	SP	>BLOCK 67-2
2616	>BLOCK 67N-2	SP	>BLOCK 67N-2
2617	>BLOCK 67-3	SP	>BLOCK 67-3
2618	>BLOCK 67N-3	SP	>BLOCK 67N-3
2621	>BLOCK 67-1	SP	>BLOCK 67-1
2622	>BLOCK 67-TOC	SP	>BLOCK 67-TOC
2623	>BLOCK 67N-1	SP	>BLOCK 67N-1
2624	>BLOCK 67N-TOC	SP	>BLOCK 67N-TOC
2628	Phase A forward	OUT	Phase A forward
2629	Phase B forward	OUT	Phase B forward
2630	Phase C forward	OUT	Phase C forward
2632	Phase A reverse	OUT	Phase A reverse
2633	Phase B reverse	OUT	Phase B reverse
2634	Phase C reverse	OUT	Phase C reverse
2635	Ground forward	OUT	Ground forward
2636	Ground reverse	OUT	Ground reverse
2637	67-1 BLOCKED	OUT	67-1 is BLOCKED
2642	67-2 picked up	OUT	67-2 picked up
2646	67N-2 picked up	OUT	67N-2 picked up
2647	67-2 Time Out	OUT	67-2 Time Out
2648	67N-2 Time Out	OUT	67N-2 Time Out
2649	67-2 TRIP	OUT	67-2 TRIP
2651	67/67-TOC OFF	OUT	67/67-TOC switched OFF
2652	67 BLOCKED	OUT	67/67-TOC is BLOCKED
2653	67 ACTIVE	OUT	67/67-TOC is ACTIVE
2655	67-2 BLOCKED	OUT	67-2 is BLOCKED
2656	67N OFF	OUT	67N/67N-TOC switched OFF
2657	67N BLOCKED	OUT	67N/67N-TOC is BLOCKED
2658	67N ACTIVE	OUT	67N/67N-TOC is ACTIVE
2659	67N-1 BLOCKED	OUT	67N-1 is BLOCKED
2660	67-1 picked up	OUT	67-1 picked up
2664	67-1 Time Out	OUT	67-1 Time Out
2665	67-1 TRIP	OUT	67-1 TRIP
2668	67N-2 BLOCKED	OUT	67N-2 is BLOCKED
2669	67-TOC BLOCKED	OUT	67-TOC is BLOCKED
2670	67-TOC pickup	OUT	67-TOC picked up
2674	67-TOC Time Out	OUT	67-TOC Time Out
2675	67-TOC TRIP	OUT	67-TOC TRIP
2676	67-TOC DiskPU	OUT	67-TOC disk emulation is ACTIVE

No.	Information	Type of Information	Comments
2677	67N-TOC BLOCKED	OUT	67N-TOC is BLOCKED
2678	67-3 TRIP	OUT	67-3 TRIP
2679	67N-2 TRIP	OUT	67N-2 TRIP
2681	67N-1 picked up	OUT	67N-1 picked up
2682	67N-1 Time Out	OUT	67N-1 Time Out
2683	67N-1 TRIP	OUT	67N-1 TRIP
2684	67N-TOCPickedup	OUT	67N-TOC picked up
2685	67N-TOC TimeOut	OUT	67N-TOC Time Out
2686	67N-TOC TRIP	OUT	67N-TOC TRIP
2687	67N-TOC Disk PU	OUT	67N-TOC disk emulation is ACTIVE
2691	67/67N pickedup	OUT	67/67N picked up
2692	67 A picked up	OUT	67/67-TOC Phase A picked up
2693	67 B picked up	OUT	67/67-TOC Phase B picked up
2694	67 C picked up	OUT	67/67-TOC Phase C picked up
2695	67N picked up	OUT	67N/67N-TOC picked up
2696	67/67N TRIP	OUT	67/67N TRIP
2697	67-3 picked up	OUT	67-3 picked up
2698	67N-3 picked up	OUT	67N-3 picked up
2699	67-3 Time Out	OUT	67-3 Time Out
2700	67N-3 Time Out	OUT	67N-3 Time Out

2.4 Dynamic Cold Load Pickup

With the cold load pickup function, pickup and delay settings of directional and non-directional time overcurrent protection can be changed over dynamically.

Applications

- It may be necessary to dynamically increase the pickup values if plant parts temporarily consume more power when they are re-energized after a prolonged dead time (e.g. air conditioning, heating). Thus, a general increase of pickup thresholds can be avoided by taking into consideration such starting conditions.
- As a further option, the pickup thresholds may be modified by an automatic reclosure function in accordance with its ready or not ready state.

Prerequisites

Note:

Dynamic cold load pickup must not be confused with the changeover option of the 4 setting groups (A to D). It is an additional feature.

It is possible to change pickup thresholds and delay times.

2.4.1 Description

Effect

There are two methods by which the device can determine if the protected equipment is de-energized:

- Via binary inputs, the device is informed of the position of the circuit breaker (address 1702 **Start Condition = Breaker Contact**).
- As a criterion a set current threshold is undershot (address 1702 **Start Condition = No Current**).

If the device determines that the protected equipment is de-energized via one of the above methods, a time, **CB Open Time**, is started and after its expiration the increased thresholds take effect.

In addition, switching between parameters can be triggered by two other events:

- By signal "79M Auto Reclosing ready" of the internal automatic reclosure function (address 1702 **Start Condition = 79 ready**). Thus the protection thresholds and the tripping times can be changed if automatic reclosure is ready for reclosing (see also Section 2.15).
- Irrespective of the setting of parameter 1702 **Start Condition**, the release of cold load pickup may always be selected via the binary input „>ACTIVATE CLP“.

Figure 2-37 shows the logic diagram for dynamic cold load pickup function.

If it is detected via the auxiliary contact or the current criterion that the system is de-energized, i.e. the circuit breaker is open, the **CB Open Time** is started. As soon as it has elapsed, the greater thresholds are enabled. When the protected equipment is re-energized (the device receives this information via the binary inputs or when threshold **BkrClosed I MIN** is exceeded), a second time delay referred to as the **Active Time** is initiated. Once it elapses, the pickup values of the relay elements return to their normal settings. This time may be reduced when current values fall below all normal pickup values for a set **Stop Time** after startup, i.e. after the circuit breaker has been closed. The starting condition of the fast reset time is made up of an OR-combination of the configured dropout conditions of all directional and non-directional overcurrent elements. When **Stop Time** is set to ∞ or when binary input „>BLK CLP stpTim“ is active, no comparison is made with the "normal" thresholds. The function is inactive and the fast reset time, if applied, is reset.

If overcurrent elements are picked up while time **Active Time** is running, the fault generally prevails until pickup drops out, using the dynamic settings. Only then the parameters are set back to "normal".

If the dynamic setting values were activated via the binary input „>ACTIVATE CLP“ or the signal "79M Auto Reclosing ready" and this cause drops out, the "normal" settings are restored immediately, even if a pickup is the result.

If the binary input „>BLOCK CLP“ is enabled, all triggered timers are reset and, as a consequence, all "normal" settings are immediately restored. If blocking occurs during an on-going fault with dynamic cold load pickup functions enabled, the timers of all overcurrent relay elements are stopped and may then be restarted based on their "normal" duration.

During power up of the protective relay with an open circuit breaker, the time delay **CB Open Time** is started, and is processed using the "normal" settings. Therefore, when the circuit breaker is closed, the "normal" settings are effective.

Figure 2-36 illustrates the timing sequence. Figure 2-37 shows the logic diagram of the dynamic cold load pickup feature.

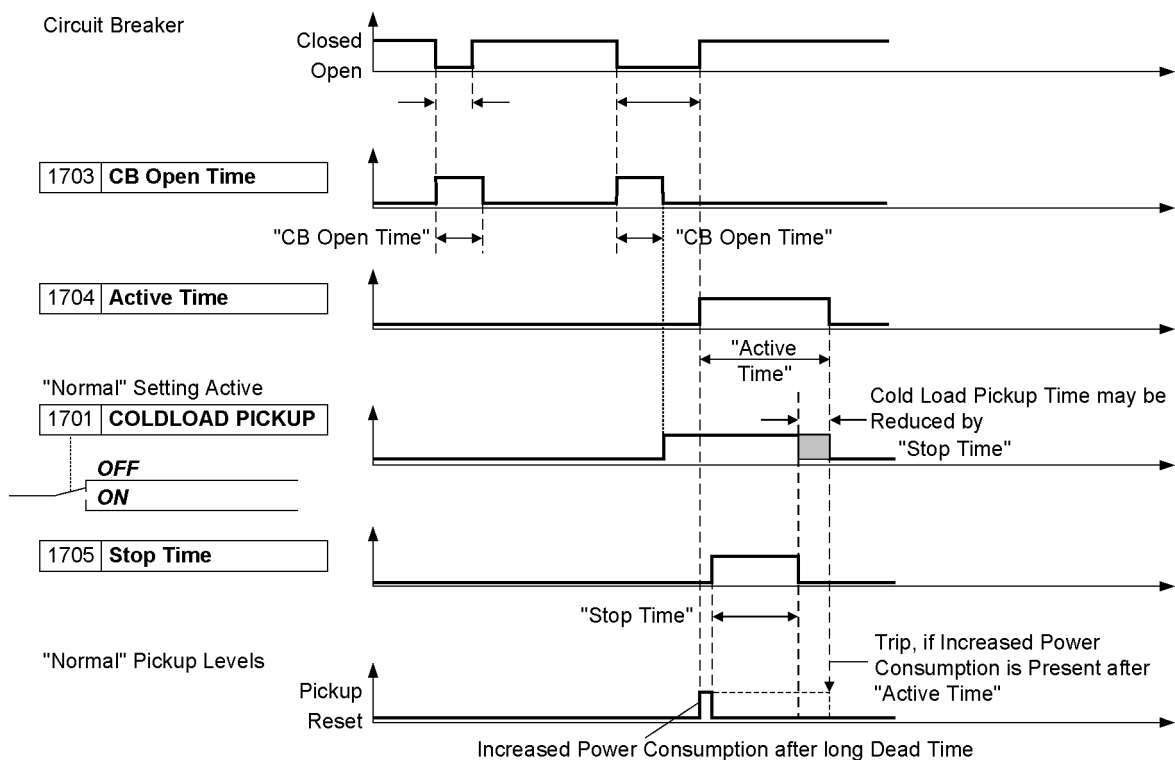

Figure 2-36 Timing charts of the dynamic cold load pickup function

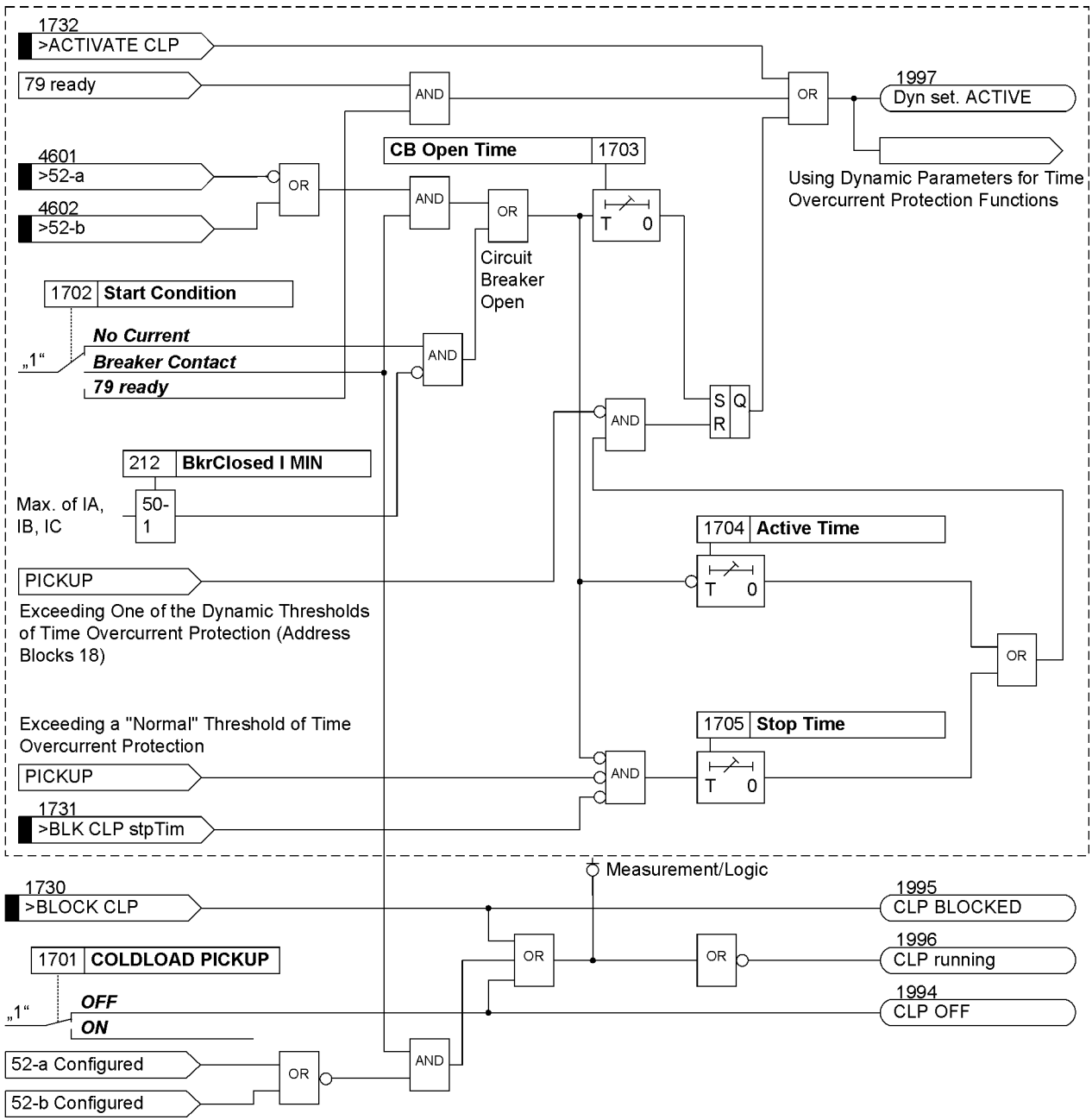

Figure 2-37 Logic diagram of the dynamic cold load pickup function (50c, 50Nc, 51c, 51Nc, 67c, 67Nc)

2.4.2 Setting Notes

General

The dynamic cold load pickup function can only be enabled if address 117 **Coldload Pickup** was set to **Enabled** during configuration of the protection functions. If not required, this function is set to **Disabled**. The function can be turned **ON** or **OFF** under address 1701 **Coldload Pickup**.

Depending on the condition that should initiate the cold load pickup function address 1702 **Start Condition** is set to either **No Current**, **Breaker Contact** or to **79 ready**. Naturally, the option **Breaker Contact** can only be selected if the device receives information regarding the switching state of the circuit breaker via at least one binary input. The option **79 ready** modifies dynamically the pickup thresholds of the directional

and non-directional time overcurrent protection when the automatic reclosing function is ready. To initiate the cold load pickup, the automatic reclosing function provides the internal signal "79M Auto Reclosing ready". It is always active when the automatic reclosing function is available, activated, unblocked, and ready for a further cycle (see also margin heading "Controlling Directional/Non-Directional Overcurrent Protection Elements via Cold Load Pickup" in Section 2.15.6).

Time Delays

There are no specific procedures on how to set the time delays at addresses 1703 **CB Open Time**, 1704 **Active Time** and 1705 **Stop Time**. These time delays must be based on the specific loading characteristics of the equipment being protected, and should be set to allow for brief overloads associated with dynamic cold load conditions.

Non-Directional 50/51 Elements (phases)

The dynamic pickup values and tripping times associated with the time overcurrent protection functions are set at address block 18 for the phase currents:

The dynamic pickup and delay settings for the high-set elements are set at addresses 1801 **50c-2 PICKUP** or 1808 **50c-3 PICKUP** and 1802 **50c-2 DELAY** or 1809 **50c-3 DELAY** respectively; the dynamic pickup and delay settings for the 67N-1 element are set at addresses 1803 **50c-1 PICKUP** and 1804 **50c-1 DELAY** respectively; and the pickup, time multiplier (for IEC curves or user-defined curves), and time dial (for ANSI curves) settings for the 67N-TOC element are set at addresses 1805 **51c PICKUP**, 1806 **51c TIME DIAL** and 1807 **51c TIME DIAL** respectively.

Non-Directional 50N/51N Elements (Ground)

The dynamic pickup values and time delays associated with non-directional time overcurrent ground protection are set at address block 19:

The dynamic pickup and delay settings for the high-set elements are set at addresses 1901 **50Nc-2 PICKUP** or 1908 **50Nc-3 PICKUP** and 1902 **50Nc-2 DELAY** or 1909 **50Nc-3 DELAY** respectively; the dynamic pickup and delay settings for the 67N-1 element are set at addresses 1903 **50Nc-1 PICKUP** and 1904 **50Nc-1 DELAY** respectively; and the pickup, time multiplier (for IEC curves or user-defined curves), and time dial (for ANSI curves) settings for the 67N-TOC element are set at addresses 1905 **51Nc PICKUP**, 1906 **51Nc T-DIAL** and 1907 **51Nc T-DIAL** respectively.

Directional 67/67-TOC Elements (phases)

The dynamic pickup values and time delays associated with directional overcurrent phase protection are set at address block 20

Addresses 2001 **67c-2 PICKUP** or 2008 **67c-3 PICKUP** and 2002 **67c-2 DELAY** or 2009 **67c-3 DELAY** define the dynamic parameters for the high-current elements, 2003 **67c-1 PICKUP** and 2004 **67c-1 DELAY** for the directional definite time overcurrent element and 2005 **67c-TOC PICKUP** in combination with 2006 **67c-TOC T-DIAL** (for IEC characteristics or user-defined characteristics) or 2007 **67c-TOC T-DIAL** (for ANSI characteristics) for the directional inverse time overcurrent protection element.

Directional 67/67N Elements (Ground)

The dynamic pickup values and time delays associated with directional overcurrent ground protection are set at address block 21:

Addresses 2101 **67Nc-2 PICKUP** or 2108 **67Nc-3 PICKUP** and 2102 **67Nc-2 DELAY** or 2109 **67Nc-3 DELAY** define the dynamic parameters for the high-current elements, 2103 **67Nc-1 PICKUP** and 2104 **67Nc-1 DELAY** for the directional definite time overcurrent element and 2105 **67Nc-TOC PICKUP** in combination with 2106 **67Nc-TOC T-DIAL** (for IEC characteristics or user-defined characteristics) or 2107 **67Nc-TOC T-DIAL** (for ANSI characteristics) for the directional inverse time overcurrent protection element.

2.4.3 Settings

The table indicates region-specific default settings. Column C (configuration) indicates the corresponding secondary nominal current of the current transformer.

Addr.	Parameter	C	Setting Options	Default Setting	Comments
1701	COLDLOAD PICKUP		OFF ON	OFF	Cold-Load-Pickup Function
1702	Start Condition		No Current Breaker Contact 79 ready	No Current	Start Condition
1703	CB Open Time		0 .. 21600 sec	3600 sec	Circuit Breaker OPEN Time
1704	Active Time		0 .. 21600 sec	3600 sec	Active Time
1705	Stop Time		1 .. 600 sec; ∞	600 sec	Stop Time
1801	50c-2 PICKUP	1A	0.10 .. 35.00 A; ∞	10.00 A	50c-2 Pickup
		5A	0.50 .. 175.00 A; ∞	50.00 A	
1802	50c-2 DELAY		0.00 .. 60.00 sec; ∞	0.00 sec	50c-2 Time Delay
1803	50c-1 PICKUP	1A	0.10 .. 35.00 A; ∞	2.00 A	50c-1 Pickup
		5A	0.50 .. 175.00 A; ∞	10.00 A	
1804	50c-1 DELAY		0.00 .. 60.00 sec; ∞	0.30 sec	50c-1 Time Delay
1805	51c PICKUP	1A	0.10 .. 4.00 A	1.50 A	51c Pickup
		5A	0.50 .. 20.00 A	7.50 A	
1806	51c TIME DIAL		0.05 .. 3.20 sec; ∞	0.50 sec	51c Time dial
1807	51c TIME DIAL		0.50 .. 15.00 ; ∞	5.00	51c Time dial
1808	50c-3 PICKUP	1A	1.00 .. 35.00 A; ∞	∞ A	50c-3 Pickup
		5A	5.00 .. 175.00 A; ∞	∞ A	
1809	50c-3 DELAY		0.00 .. 60.00 sec; ∞	0.00 sec	50c-3 Time Delay
1901	50Nc-2 PICKUP	1A	0.05 .. 35.00 A; ∞	7.00 A	50Nc-2 Pickup
		5A	0.25 .. 175.00 A; ∞	35.00 A	
1902	50Nc-2 DELAY		0.00 .. 60.00 sec; ∞	0.00 sec	50Nc-2 Time Delay
1903	50Nc-1 PICKUP	1A	0.05 .. 35.00 A; ∞	1.50 A	50Nc-1 Pickup
		5A	0.25 .. 175.00 A; ∞	7.50 A	
1904	50Nc-1 DELAY		0.00 .. 60.00 sec; ∞	0.30 sec	50Nc-1 Time Delay
1905	51Nc PICKUP	1A	0.05 .. 4.00 A	1.00 A	51Nc Pickup
		5A	0.25 .. 20.00 A	5.00 A	
1906	51Nc T-DIAL		0.05 .. 3.20 sec; ∞	0.50 sec	51Nc Time Dial
1907	51Nc T-DIAL		0.50 .. 15.00 ; ∞	5.00	51Nc Time Dial
1908	50Nc-3 PICKUP		0.05 .. 35.00 A; ∞	∞ A	50Nc-3 Pickup
1909	50Nc-3 DELAY		0.00 .. 60.00 sec; ∞	0.00 sec	50Nc-3 Time Delay
2001	67c-2 PICKUP	1A	0.10 .. 35.00 A; ∞	10.00 A	67c-2 Pickup
		5A	0.50 .. 175.00 A; ∞	50.00 A	

Addr.	Parameter	C	Setting Options	Default Setting	Comments
2002	67c-2 DELAY		0.00 .. 60.00 sec; ∞	0.00 sec	67c-2 Time Delay
2003	67c-1 PICKUP	1A	0.10 .. 35.00 A; ∞	2.00 A	67c-1 Pickup
		5A	0.50 .. 175.00 A; ∞	10.00 A	
2004	67c-1 DELAY		0.00 .. 60.00 sec; ∞	0.30 sec	67c-1 Time Delay
2005	67c-TOC PICKUP	1A	0.10 .. 4.00 A	1.50 A	67c Pickup
		5A	0.50 .. 20.00 A	7.50 A	
2006	67c-TOC T-DIAL		0.05 .. 3.20 sec; ∞	0.50 sec	67c Time Dial
2007	67c-TOC T-DIAL		0.50 .. 15.00 ; ∞	5.00	67c Time Dial
2008	67c-3 PICKUP	1A	1.00 .. 35.00 A; ∞	∞ A	67c-3 Pickup
		5A	5.00 .. 175.00 A; ∞	∞ A	
2009	67c-3 DELAY		0.00 .. 60.00 sec; ∞	0.00 sec	67c-3 Time Delay
2101	67Nc-2 PICKUP	1A	0.05 .. 35.00 A; ∞	7.00 A	67Nc-2 Pickup
		5A	0.25 .. 175.00 A; ∞	35.00 A	
2102	67Nc-2 DELAY		0.00 .. 60.00 sec; ∞	0.00 sec	67Nc-2 Time Delay
2103	67Nc-1 PICKUP	1A	0.05 .. 35.00 A; ∞	1.50 A	67Nc-1 Pickup
		5A	0.25 .. 175.00 A; ∞	7.50 A	
2104	67Nc-1 DELAY		0.00 .. 60.00 sec; ∞	0.30 sec	67Nc-1 Time Delay
2105	67Nc-TOC PICKUP	1A	0.05 .. 4.00 A	1.00 A	67Nc-TOC Pickup
		5A	0.25 .. 20.00 A	5.00 A	
2106	67Nc-TOC T-DIAL		0.05 .. 3.20 sec; ∞	0.50 sec	67Nc-TOC Time Dial
2107	67Nc-TOC T-DIAL		0.50 .. 15.00 ; ∞	5.00	67Nc-TOC Time Dial
2108	67Nc-3 PICKUP		0.25 .. 35.00 A; ∞	∞ A	67Nc-3 Pickup
2109	67Nc-3 DELAY		0.00 .. 60.00 sec; ∞	0.00 sec	67Nc-3 Time Delay

2.4.4 Information List

No.	Information	Type of Information	Comments
1730	>BLOCK CLP	SP	>BLOCK Cold-Load-Pickup
1731	>BLK CLP stpTim	SP	>BLOCK Cold-Load-Pickup stop timer
1732	>ACTIVATE CLP	SP	>ACTIVATE Cold-Load-Pickup
1994	CLP OFF	OUT	Cold-Load-Pickup switched OFF
1995	CLP BLOCKED	OUT	Cold-Load-Pickup is BLOCKED
1996	CLP running	OUT	Cold-Load-Pickup is RUNNING
1997	Dyn set. ACTIVE	OUT	Dynamic settings are ACTIVE

2.5 Single-Phase Overcurrent Protection

The single-phase overcurrent protection evaluates the current that is measured by the sensitive I_{NS} input.

Applications

- Plain ground fault protection at a power transformer;
- Sensitive tank leakage protection.

2.5.1 Functional Description

The single-phase definite time overcurrent ground protection is illustrated by the tripping characteristic as shown in Figure 2-38. The current to be measured is filtered by numerical algorithms. Because of the high sensitivity a particularly narrow band filter is used. The current pickup thresholds and tripping times can be set. The detected current is compared to the pickup value **50 1Ph-1 PICKUP** or **50 1Ph-2 PICKUP** and reported if this is violated. After expiry of the respective delay time **50 1Ph-1 DELAY** or **50 1Ph-2 DELAY**, the trip command is issued. The two elements together form a two-stage protection. The dropout value is approximately 95% of the pickup value for currents greater than $I > 0.3 \cdot I_{Nom}$.

The current filter is bypassed if currents are extremely high in order to achieve a short tripping time. This occurs automatically as soon as the instantaneous value of the current exceeds the set value of the element by at least factor $2 \cdot \sqrt{2}$.

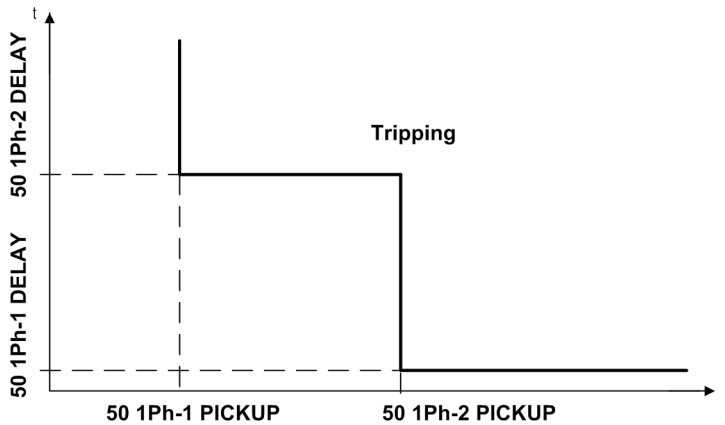

Figure 2-38 Two-stage characteristic of the single-phase time-overcurrent protection

The following figure shows the logic diagram of the single-phase overcurrent protection function.

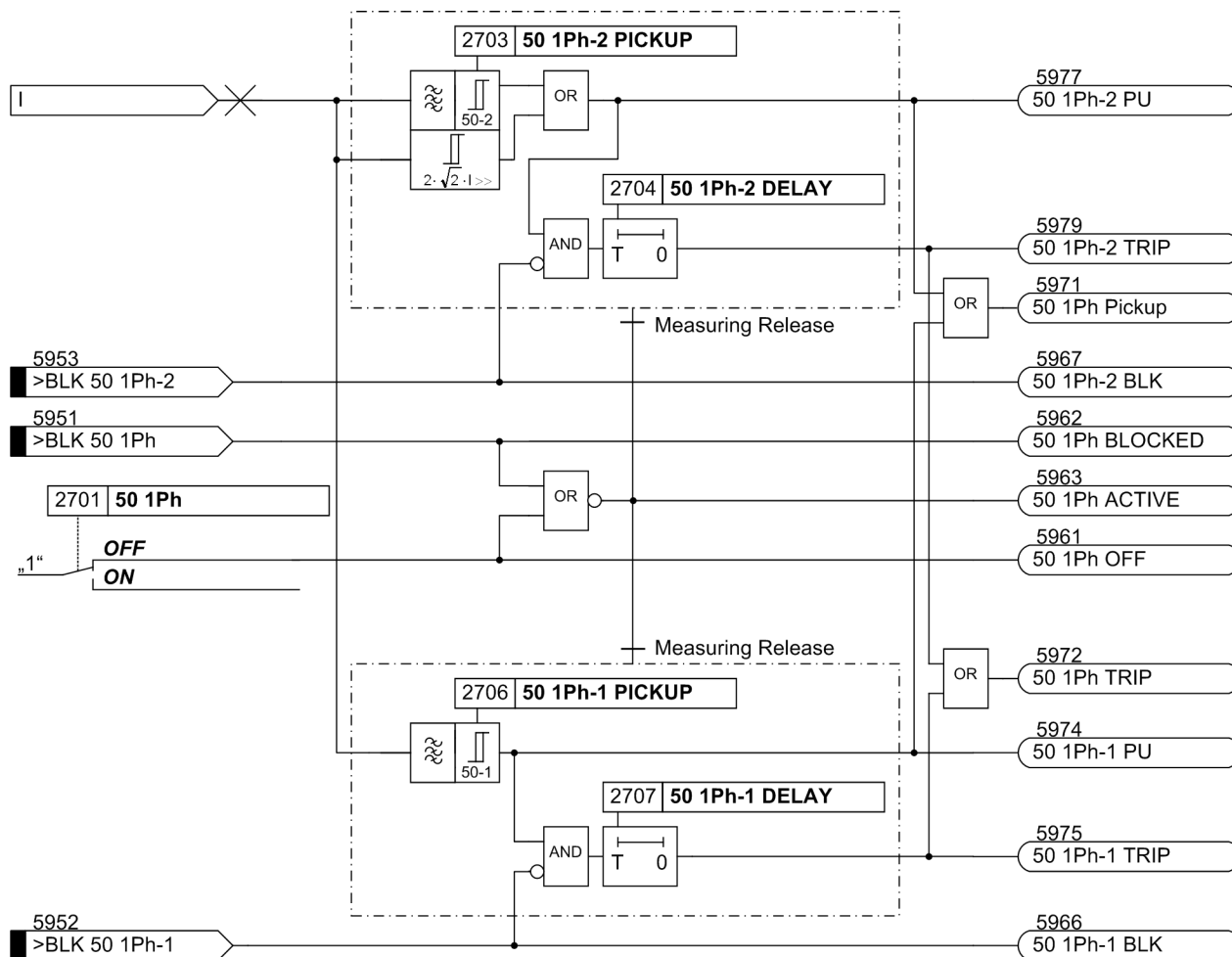

Figure 2-39 Logic diagram of the single-phase time overcurrent protection

2.5.2 High-impedance Ground Fault Unit Protection

Application Examples

The high impedance protection concept is based on measuring the voltage across the paralleled CT's to a common high-resistive resistor.

The CTs must be of the same design and feature at least a separate core for high-impedance protection. In particular, they must have the same transformer ratios and approximately identical knee-point voltage.

With 7SJ80 the high-impedance principle is particularly suited for detection of ground faults in transformers, generators, motors and shunt reactors in grounded systems.

Figure 2-40 (left side) illustrates an application example for a grounded transformer winding or a grounded generator. The example on the right side shows an ungrounded transformer winding or an ungrounded generator where the grounding of the system is assumed to be somewhere else.

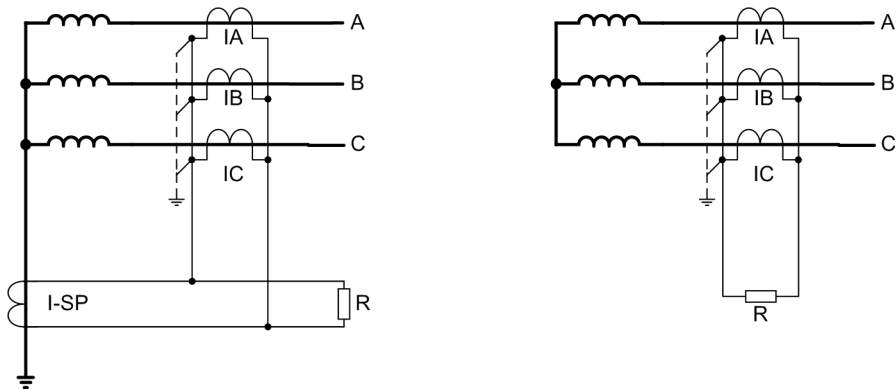

Figure 2-40 Ground fault protection according to the high-impedance principle

Function of the High-Impedance Principle

The high-impedance principle is explained on the basis of a grounded transformer winding.

No zero sequence current will flow during normal operation, i.e. the neutral point current is $I_{SP} = 0$ and the phase currents are $3 I_0 = I_A + I_B + I_C = 0$.

In case of an external ground fault (left in Figure 2-41), whose fault current is supplied via the grounded neutral point, the same current flows through the transformer neutral point and the phases. The corresponding secondary currents (all current transformers have the same transformation ratio) compensate each other; they are connected in series. Across resistor R only a small voltage is generated. It originates from the inner resistance of the transformers and the connecting cables of the transformers. Even if any current transformer experiences a partial saturation, it will become low-ohmic for the period of saturation and creates a low-ohmic shunt to the high-ohmic resistor R. Thus, the high resistance of the resistor also has a stabilizing effect (the so-called resistance stabilization).

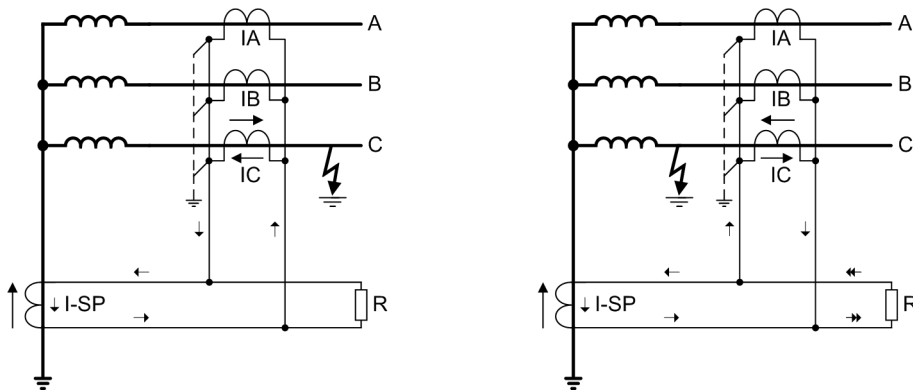

Figure 2-41 Principle of ground fault protection according to the high-impedance principle

When a ground fault occurs in the protected zone (Fig. 2-41 right), there is always a neutral point current I_{SP} . The grounding conditions in the rest of the network determine how strong a zero sequence current from the system is. A secondary current which is equal to the total fault current tries to pass through the resistor R. Since the latter is high-resistive, a high voltage emerges immediately. Therefore, the current transformers get saturated. The RMS voltage across the resistor approximately corresponds to the knee-point voltage of the current transformers.

Resistance R is sized such that, even with the very lowest ground fault current to be detected, it generates a secondary voltage, which is equal to half the saturation voltage of current transformers (see also notes on "Dimensioning" in Subsection 2.5.4).

High Impedance Protection

With 7SJ80 the sensitive measuring input I_{NS} is used for high-impedance protection. As this is a current input, the protection detects current through the resistor instead of the voltage across the resistor R.

Figure 2-42 illustrates the connection diagram. The protection device is connected in series to resistor R and measures its current.

Varistor B limits the voltage when internal faults occur. High voltage peaks emerging with transformer saturation are cut by the varistor. At the same time, voltage is smoothed without reduction of the mean value.

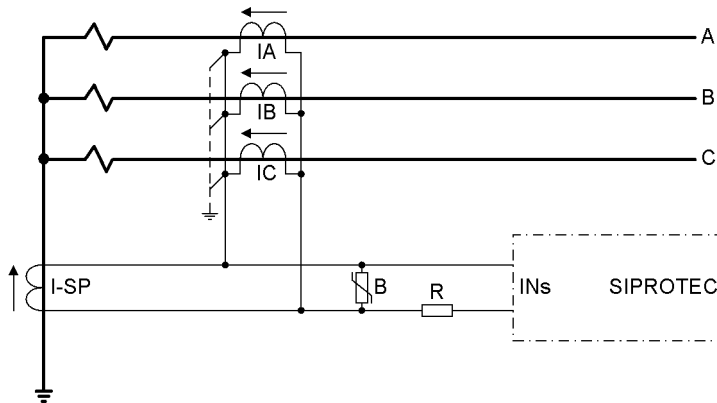

Figure 2-42 Connection scheme of the ground fault differential protection according to the high impedance principle

For protection against overvoltages it is also important that the device is directly connected to the grounded side of the current transformers so that the high voltage at the resistor can be kept away from the device.

The high-impedance differential protection can be used analogously for generators and shunt reactors. All current transformers at the overvoltage side, the undervoltage side and the current transformer at the starpoint have to be connected in parallel when using auto-transformers.

In principle, this procedure can be applied to every protected object. When applied as busbar protection, for example, the device is connected to the parallel connection of all feeder current transformers via the resistor.

2.5.3 Tank Leakage Protection

Application Example

The tank leakage protection has the task to detect ground leakage — even high-ohmic — between a phase and the tank of a transformer. The tank must be isolated from ground. A conductor links the tank to ground, and the current through this conductor is fed to a current input of the protection device. When tank leakage occurs, a fault current (tank leakage current) will flow through the ground conductor to ground. This tank leakage current is detected by the single-phase overcurrent protection as an overcurrent; an instantaneous or delayed trip command is issued in order to disconnect all sides of the transformer.

A sensitive single-phase current input is normally used for tank leakage protection.

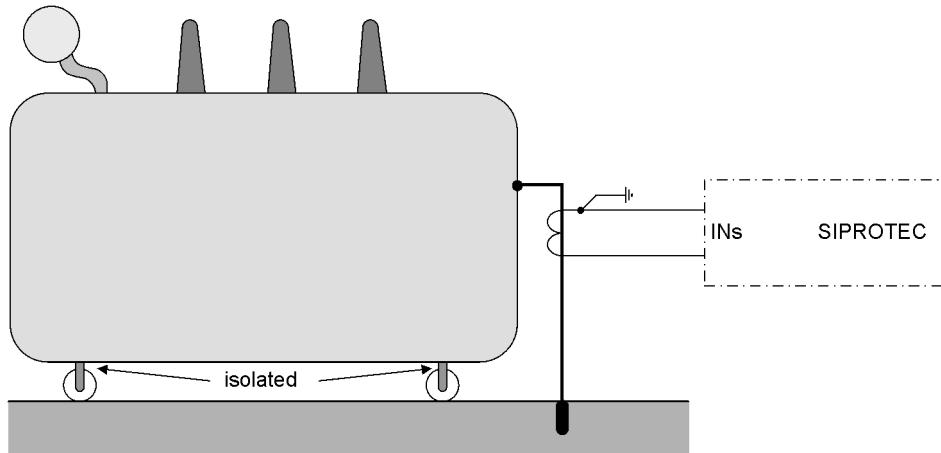

Figure 2-43 Tank protection principle

2.5.4 Setting Notes

General

Single-phase time overcurrent protection can be set **ON** or **OFF** at address 2701 **50 1Ph**.

The settings are based on the particular application.

The pickup value for **50 1Ph-2 PICKUP** is set in address 2703, the pickup value for **50 1Ph-1 PICKUP** at address 2706. If only one element is required, set the one not required to ∞ .

A trip time delay can be set in address 2704 **50 1Ph-2 DELAY** for the 50-2 element and for the 50-1 element in address 2707 **50 1Ph-1 DELAY**. With setting 0 s no delay takes place.

The selected times are additional time delays and do not include the operating time (measuring time, etc.) of the elements. The delay can also be set to ∞ ; the corresponding element will then not trip after pickup, but the pickup is reported.

Special notes are given in the following for the use as high-impedance unit protection and tank leakage protection.

Use as High Impedance Protection

The use as high-impedance protection requires that neutral point current detection is possible in the system in addition to phase current detection (see example in Figure 2-42). Furthermore, a sensitive input transformer must be available at the device input I_{Ns} . In this case, only the pickup value for single-phase overcurrent protection is set at the 7SJ80 device for the current at input I_{Ns} .

The entire function of high impedance protection, however, depends on the interaction of current transformer characteristics, external resistor R and voltage across R. The following section gives information on this topic.

Current Transformer Data for High-impedance Protection

All current transformers must have an identical transformation ratio and nearly equal knee-point voltage. This is usually the case if they are of equal design and identical rated data. The knee-point voltage can be approximately calculated from the rated data of a CT as follows:

$$V_{KPV} = \left(R_I + \frac{P_{Nom}}{I_{Nom}^2} \right) \cdot ALF \cdot I_{Nom}$$

- V_{KPV} Knee-point voltage
- R_I Internal burden of the CT
- P_{Nom} Nominal power of the CT
- I_{Nom} Secondary nominal current of CT
- ALF Rated accuracy limit factor of the CT

The nominal current, nominal power and accuracy limit factor are normally stated on the rating plate of the current transformer, e.g.

Current transformer 800/5; 5P10; 30 VA

That means

- $I_{Nom} = 5 \text{ A (from 800/5)}$
- ALF = 10 (from 5P**10**)
- $P_{Nom} = 30 \text{ VA}$

The internal burden is often stated in the test report of the current transformer. If not, it can be derived from a DC measurement on the secondary winding.

Calculation Example:

CT 800/5; 5P10; 30 VA with $R_i = 0.3 \Omega$

$$V_{KPV} = \left(R_I + \frac{P_{Nom}}{I_{Nom}^2} \right) \cdot ALF \cdot I_{Nom} = \left(0.3 \Omega + \frac{30 \text{ VA}}{(5 \text{ A})^2} \right) \cdot 10 \cdot 5 \text{ A} = 75 \text{ V}$$

or

CT 800/1; 5P10; 30 VA with $R_i = 5 \Omega$

$$V_{KPV} = \left(R_I + \frac{P_{Nom}}{I_{Nom}^2} \right) \cdot ALF \cdot I_{Nom} = \left(5 \Omega + \frac{30 \text{ VA}}{(1 \text{ A})^2} \right) \cdot 10 \cdot 1 \text{ A} = 350 \text{ V}$$

Besides the CT data, the resistance of the longest connection lead between the CTs and the 7SJ80 device must be known.

Stability with High-impedance Protection

The stability condition is based on the following simplified assumption: If there is an external fault, **one** of the current transformers gets totally saturated. The other ones will continue transmitting their (partial) currents. In theory, this is the most unfavorable case. Since, in practice, it is also the saturated transformer which supplies current, an automatic safety margin is guaranteed.

Figure 2-44 shows a simplified equivalent circuit. CT1 and CT2 are assumed as ideal transformers with their inner resistances R_{i1} and R_{i2} . R_a are the resistances of the connecting cables between current transformers and resistor R. They are multiplied by 2 as they have a forward and a return line. R_{a2} is the resistance of the longest connecting cable.

CT1 transmits current I_1 . CT2 shall be saturated. Because of saturation the transformer represents a low-resistance shunt which is illustrated by a dashed short-circuit line.

$R \gg (2R_{a2} + R_{i2})$ is a further prerequisite.

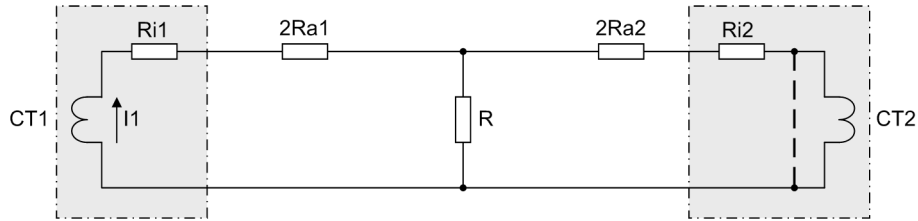

Figure 2-44 Simplified equivalent circuit of a circulating current system for high-impedance protection

The voltage across R is then

$$V_R = I_1 \cdot (2R_{a2} + R_{i2})$$

It is assumed that the pickup value of the 7SJ80 corresponds to half the knee-point voltage of the current transformers. In the balanced case results

$$V_R = V_{KPV} / 2$$

This results in a stability limit I_{SL} , i.e. the maximum through-fault current below which the scheme remains stable:

$$I_{SL} = \frac{V_{KPV} / 2}{2 \cdot R_{a2} + R_{i2}}$$

Calculation Example:

For the 5 A CT as above with $V_{KPV} = 75 \text{ V}$ and $R_i = 0.3 \Omega$

longest CT connection lead 22 m (24.06 yd) with 4 mm^2 cross-section; this corresponds to $R_a = 0.1 \Omega$

$$I_{SL} = \frac{V_{KPV} / 2}{2 \cdot R_{a2} + R_{i2}} = \frac{37.5 \text{ V}}{2 \cdot 0.1 \Omega + 0.3 \Omega} = 75 \text{ A}$$

that is $15 \times$ rated current or 12 kA primary.

For the 1 A CT as above with $V_{KPV} = 350 \text{ V}$ and $R_i = 5 \Omega$

longest CT connection lead 107 m (117.02 yd) with 2.5 mm^2 cross-section, results in $R_a = 0.75 \Omega$

$$I_{SL} = \frac{V_{KPV} / 2}{2 \cdot R_{a2} + R_{i2}} = \frac{175 \text{ V}}{2 \cdot 0.75 \Omega + 5 \Omega} = 27 \text{ A}$$

that is $27 \times$ rated current or 21.6 kA primary.

Sensitivity Consideration for High Impedance Differential Protection

The voltage present at the CT set is forwarded to the protective relay across a series resistor R as proportional current for evaluation. The following considerations are relevant for dimensioning the resistor:

As already mentioned, it is desired that the high-impedance protection should pick up at half the knee-point voltage of the CT's. The resistor R can be calculated on this basis.

Since the device measures the current flowing through the resistor, resistor and measuring input of the device must be connected in series. Since, furthermore, the resistance shall be high-resistance (condition: $R \gg 2R_{a2} + R_{i2}$, as mentioned above), the inherent resistance of the measuring input can be neglected. The resistance is then calculated from the pickup current I_{pu} and half the knee-point voltage:

$$R = \frac{V_{KPV}/2}{I_{pu}}$$

Calculation Example:

For the 5 A CT as above

desired pickup value $I_{pu} = 0.1$ A (equivalent to 16 A primary)

$$R = \frac{V_{KPV}/2}{I_{pu}} = \frac{75 \text{ V}/2}{0.1 \text{ A}} = 375 \ \Omega$$

For the 1 A CT as above

desired pickup value $I_{pu} = 0.05$ A (equivalent to 40 A primary)

$$R = \frac{V_{KPV}/2}{I_{pu}} = \frac{350 \text{ V}/2}{0.05 \text{ A}} = 3500 \ \Omega$$

The required short-term power of the resistor is derived from the knee-point voltage and the resistance:

$$P_{\text{cont}} \geq \frac{(V_{KPV}/2)^2}{R} = \frac{37.5^2}{375} = 3.75 \text{ W} \quad \text{for the 5 A CT example}$$

$$P_{\text{cont}} \geq \frac{(V_{KPV}/2)^2}{R} = \frac{175^2}{3500} = 8.75 \text{ W} \quad \text{for the 1 A CT example}$$

Furthermore, series resistor R must be rated for a fault current applying for approx. 0.5 s. This time is usually sufficient for the backup protection to clear the fault.

The thermal load of the series resistor depends on the voltage $V_{\text{rms,stab}}$ applying during an internal fault. It is calculated according to the following formulas:

$$P_{0.5 \text{ s}} = \frac{V_{\text{rms,stab}}^2}{R} = \frac{579.7^2}{375} = 896 \text{ W} \quad \text{for the 5 A CT example}$$

$$V_{\text{rms,stab}} = 1.3 \cdot \sqrt[4]{V_{KPV}^3 \cdot R \cdot I_{k,\text{max,int}}} = 1.3 \cdot \sqrt[4]{350^3 \cdot 3500 \cdot 50} = 2151.6 \text{ V} \quad \text{for 1 A CT}$$

where $I_{k,\text{max,int}}$ corresponds to the maximum fault current during an internal fault.

For the 5 A current transformer 800/5 with 40 kA primary, $I_{k,\text{max,int}}$ equals 250 A secondary.

This yields a short-time load over 0.5 s for the series resistor of:

$$P_{0.5 \text{ s}} = \frac{V_{\text{rms,stab}}^2}{R} = \frac{579.7^2}{375} = 896 \text{ W} \quad \text{for the 5 A CT example}$$

$$P_{0.5 \text{ s}} = \frac{V_{\text{rms,stab}}^2}{R} = \frac{2151.6^2}{3500} = 1322.7 \text{ W} \quad \text{for the 1 A CT example}$$

Please bear in mind that when choosing a higher pickup value I_{pu} , the resistance must be decreased and, in doing so, power loss will increase significantly.

The varistor B (see following figure) must be dimensioned such that it remains high-resistive until reaching knee-point voltage, e.g.

approx. 100 V for 5 A CT,

approx. 500 V for 1 A CT.

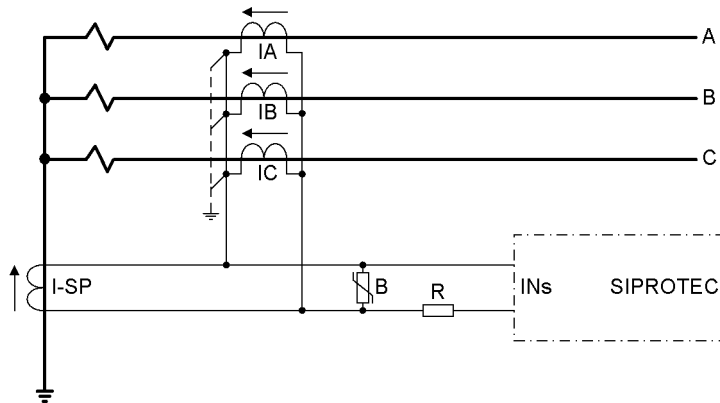

Figure 2-45 Connection scheme of the ground fault differential protection according to the high impedance principle

Even with an unfavorable external circuit, the maximum voltage peaks should not exceed 2 kV for safety reasons.

If performance makes it necessary to switch several varistors in parallel, preference should be given to types with a flat characteristic to avoid asymmetrical loading. therefore recommend the following types from METRO-SIL:

600A/S1/S256 ($k = 450, \beta = 0.25$)

600A/S1/S1088 ($k = 900, \beta = 0.25$)

The pickup value (0.1 A or 0.05 A in the example) is set in address 2706 **50 1Ph-1 PICKUP** in the device. The 50-2 element is not required (address 2703 **50 1Ph-2 PICKUP** = ∞).

The trip command of the protection can be delayed via address 2707 **50 1Ph-1 DELAY**. Normally, such delay is set to **0**.

If a higher number of CTs is connected in parallel, e.g. as busbar protection with several feeders, the magnetizing currents of the transformers connected in parallel cannot be neglected anymore. In this case, the magnetizing currents at half the knee-point voltage (corresponds to the setting value) have to be summed up. These magnetizing currents reduce the current through the resistor R. Therefore the actual pickup value will be correspondingly higher.

Use as Tank Leakage Protection

The use as tank leakage protection requires a sensitive input transformer to be available at the device input I_{NS} . In this case, only the pickup value for single-phase overcurrent protection is set at the 7SJ80 device for the current at input I_{NS} .

The tank leakage protection is a sensitive overcurrent protection which detects the leakage current between the isolated transformer tank and ground. Its sensitivity is set in address 2706 **50 1Ph-1 PICKUP**. The 50-2 element is not required (address 2703 **50 1Ph-2 PICKUP** = ∞).

The trip command of the element can be delayed in address 2707 **50 1Ph-1 DELAY**. It is normally set to **0**.

2.5.5 Settings

The table indicates region-specific default settings. Column C (configuration) indicates the corresponding secondary nominal current of the current transformer.

Addr.	Parameter	C	Setting Options	Default Setting	Comments
2701	50 1Ph		OFF ON	OFF	50 1Ph
2703	50 1Ph-2 PICKUP	1A	0.001 .. 1.600 A; ∞	0.300 A	50 1Ph-2 Pickup
		5A	0.005 .. 8.000 A; ∞	1.500 A	
2704	50 1Ph-2 DELAY		0.00 .. 60.00 sec; ∞	0.10 sec	50 1Ph-2 Time Delay
2706	50 1Ph-1 PICKUP	1A	0.001 .. 1.600 A; ∞	0.100 A	50 1Ph-1 Pickup
		5A	0.005 .. 8.000 A; ∞	0.500 A	
2707	50 1Ph-1 DELAY		0.00 .. 60.00 sec; ∞	0.50 sec	50 1Ph-1 Time Delay

2.5.6 Information List

No.	Information	Type of Information	Comments
5951	>BLK 50 1Ph	SP	>BLOCK 50 1Ph
5952	>BLK 50 1Ph-1	SP	>BLOCK 50 1Ph-1
5953	>BLK 50 1Ph-2	SP	>BLOCK 50 1Ph-2
5961	50 1Ph OFF	OUT	50 1Ph is OFF
5962	50 1Ph BLOCKED	OUT	50 1Ph is BLOCKED
5963	50 1Ph ACTIVE	OUT	50 1Ph is ACTIVE
5966	50 1Ph-1 BLK	OUT	50 1Ph-1 is BLOCKED
5967	50 1Ph-2 BLK	OUT	50 1Ph-2 is BLOCKED
5971	50 1Ph Pickup	OUT	50 1Ph picked up
5972	50 1Ph TRIP	OUT	50 1Ph TRIP
5974	50 1Ph-1 PU	OUT	50 1Ph-1 picked up
5975	50 1Ph-1 TRIP	OUT	50 1Ph-1 TRIP
5977	50 1Ph-2 PU	OUT	50 1Ph-2 picked up
5979	50 1Ph-2 TRIP	OUT	50 1Ph-2 TRIP
5980	50 1Ph I:	VI	50 1Ph: I at pick up

2.6 Voltage Protection 27, 59

Voltage protection has the task to protect electrical equipment against undervoltage and overvoltage. Both operational states are abnormal as overvoltage may cause for example insulation problems or undervoltage may cause stability problems.

There are two elements each available for overvoltage protection and undervoltage protection.

Applications

- Abnormally high voltages often occur e.g. in low loaded, long distance transmission lines, in islanded systems when generator voltage regulation fails, or after full load rejection of a generator from the system.
- The undervoltage protection function detects voltage collapses on transmission lines and electrical machines and prevents inadmissible operating states and a possible loss of stability.

From V04.73 on special voltage and frequency protection functions according to the standard CEI 0-16 were added.

If chosen, the standard / global voltage and frequency protection functions are replaced by the CEI 0-16 specific ones.

The selection is done via MLFB position 14: if *F* is chosen, the global functions are active, if *G* is chosen, the CEI 0-16 functions are active.

In the following chapters both voltage protection standards will be described separately.

2.6.1 Voltage protection (Global standard)

2.6.1.1 Measurement Principle

Connection/Measured Values

The voltages supplied to the device may correspond to the three phase-to-Ground voltages V_{A-N} , V_{B-N} , V_{C-N} or the two phase-to-phase voltages (V_{A-B} , V_{B-C}) and the displacement voltage (ground voltage V_N) or - in the case of a single-phase connection - any phase-to-Ground voltage. The connection type has been specified during the configuration in parameter 213 **VT Connect. 3ph** (see 2.1.3.2).

The following table indicates which voltages can be evaluated by the function. The settings for this are made in the **P.System Data 1** (see Section 2.1.3.2). Furthermore, it is indicated to which value the threshold must be set. All voltages are fundamental frequency values.

Table 2-9 Voltage protection, selectable voltages

Function	Connection, three-phase (parameter 213)	Selectable voltage (parameter 614 / 615)	Threshold to be set as
----------	---	--	------------------------

Overvoltage	Van, Vbn, Vcn	Vphph (largest phase-to-phase voltage)	Phase-to-phase voltage
		Vph-n (largest phase-to-Ground voltage)	Phase-to-Ground voltage
		V1 (positive sequence voltage)	Positive sequence voltage calculated from phase-to-Ground voltage or phase-to-phase voltage / $\sqrt{3}$
		V2 (negative sequence voltage)	Negative sequence voltage
	Vab, Vbc, VGnd Vab, Vbc Vab, Vbc, VSyn Vab, Vbc, Vx	Vphph (largest phase-to-phase voltage)	Phase-to-phase voltage
		V1 (positive sequence voltage)	Positive sequence voltage
		V2 (negative sequence voltage)	Negative sequence voltage
Vph-g, VSyn	None (direct evaluation of the voltage connected to voltage input 1)	Direct voltage value	
Undervoltage	Van, Vbn, Vcn	Vphph (smallest phase-to-phase voltage)	Phase-to-phase voltage
		Vph-n (smallest phase-to-Ground voltage)	Phase-to-Ground voltage
		V1 (positive sequence voltage)	Positive sequence voltage · $\sqrt{3}$
		V2 (negative sequence voltage)	Negative sequence voltage
	Vab, Vbc, VGnd Vab, Vbc Vab, Vbc, VSyn Vab, Vbc, Vx	Vphph (smallest phase-to-phase voltage)	Phase-to-phase voltage
		V1 (positive sequence voltage)	Positive sequence voltage · $\sqrt{3}$
		V2 (negative sequence voltage)	Negative sequence voltage
Vph-g, VSyn	None (direct evaluation of the voltage connected to voltage input 1)	Direct voltage value	

The positive and negative sequence voltages stated in the table are calculated from the phase-to-Ground voltages.



Note

For capacitive voltage connections, the same values as with the connection type **Van**, **Vbn**, **Vcn** are used.

Current Criterion

Depending on the system, the primary voltage transformers are arranged either on the supply side or the load side of the associated circuit breaker. These different arrangements lead to different behaviour of the voltage protection function when a fault occurs. When a tripping command is issued and a circuit breaker is opened, full voltage remains on the supply side while the load side voltage becomes zero. When voltage supply is suppressed, undervoltage protection, for instance, will remain picked up. If pickup is to drop out, the current can be used as an additional criterion for pickup of undervoltage protection (current supervision CS). Undervoltage pickup can only be maintained when the undervoltage criterion satisfied and a settable minimum current level (**BkrClosed I MIN**) are exceeded. Here, the largest of the three phase currents is used. When the current decreases below the minimum current setting after the circuit breaker has opened, undervoltage protection drops out.



Note

If parameter **CURRENT SUPERV.** is set to disabled in address 5120, the device picks up immediately without measurement voltage and the undervoltage protection function in pickup. Apply measuring voltage or block the voltage protection to continue with configuration. Moreover you have the option of setting a flag via device operation for blocking the voltage protection. This initiates the reset of the pickup and device configuration can be resumed.

2.6.1.2 Overvoltage Protection 59

Function

The overvoltage protection has two elements. In case of a high overvoltage, tripping switch off is performed with a short-time delay, whereas in case of less severe overvoltages, the tripping is performed with a longer time delay. When one of the adjustable settings is exceeded, the 59 element picks up and trips after an adjustable time delay has elapsed. The time delay is not dependent on the magnitude of the overvoltage.

The dropout ratio for the two overvoltage elements ($= V_{\text{dropout value}}/V_{\text{pickup value}}$) can be set.

The following figure shows the logic diagram of the overvoltage protection function.

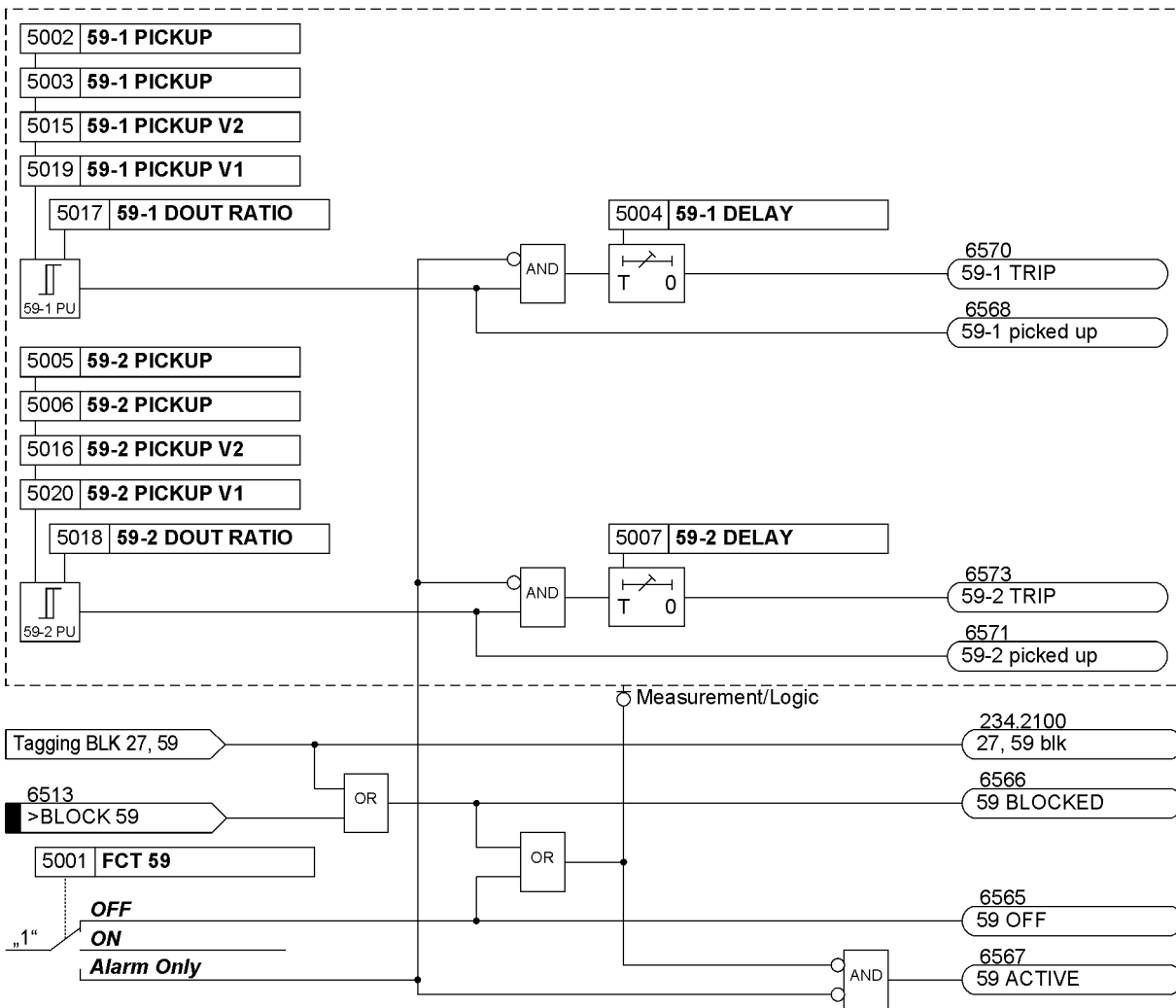

Figure 2-46 Logic diagram of the overvoltage protection

2.6.1.3 Undervoltage Protection 27

Function

Undervoltage protection consists of two definite time elements (**27-1 PICKUP** and **27-2 PICKUP**). Therefore, tripping can be time-coordinated depending on how severe voltage collapses are. Voltage thresholds and time delays can be set individually for both elements.

The dropout ratio for the two undervoltage elements ($= V_{\text{dropout value}}/V_{\text{pickup value}}$) can be set.

Like the other protection functions, the undervoltage protection operates in an extended frequency range. This ensures that the protection function is maintained even for the protection of e.g. decelerating motors. However, the r.m.s. value of the positive voltage component is considered too small when the frequency deviates considerably so that the device will tend to overfunction.

Figure 2-47 shows a typical voltage profile during a fault for source side connection of the voltage transformers. Because full voltage is present after the circuit breaker has been opened, current supervision CS described above is not necessary in this case. After the voltage has dropped below the pickup setting, tripping is initiated after time delay **27-1 DELAY**. As long as the voltage remains below the dropout setting, reclosing is blocked. Only after the fault has been cleared, i.e. when the voltage increases above the dropout level, the element drops out and allows reclosing of the circuit breaker.

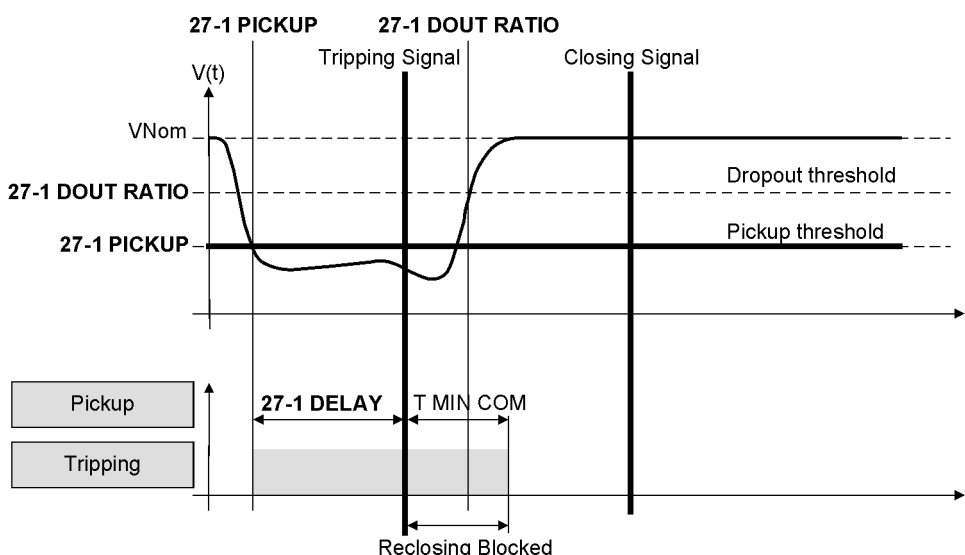

Figure 2-47 Typical fault profile for source side connection of the voltage transformer (without current supervision)

Figure 2-48 shows a fault profile for a load side connection of the voltage transformers. When the circuit breaker is open, the voltage disappears (the voltage remains below the pickup setting), and current supervision is used to ensure that pickup drops out after the circuit breaker has opened (**BkrClosed I MIN**).

After the voltage has dropped below the pickup setting, tripping is initiated after time delay **27-1 DELAY**. When the circuit breaker opens, voltage decreases to zero and undervoltage pickup is maintained. The current value also decreases to zero so that current criterion is reset as soon as the release threshold (**BkrClosed I MIN**) is exceeded. Pickup of the protection function is also reset by the action of the AND-combination of voltage and current. As a consequence, energization is admitted anew when the minimum command time elapsed.

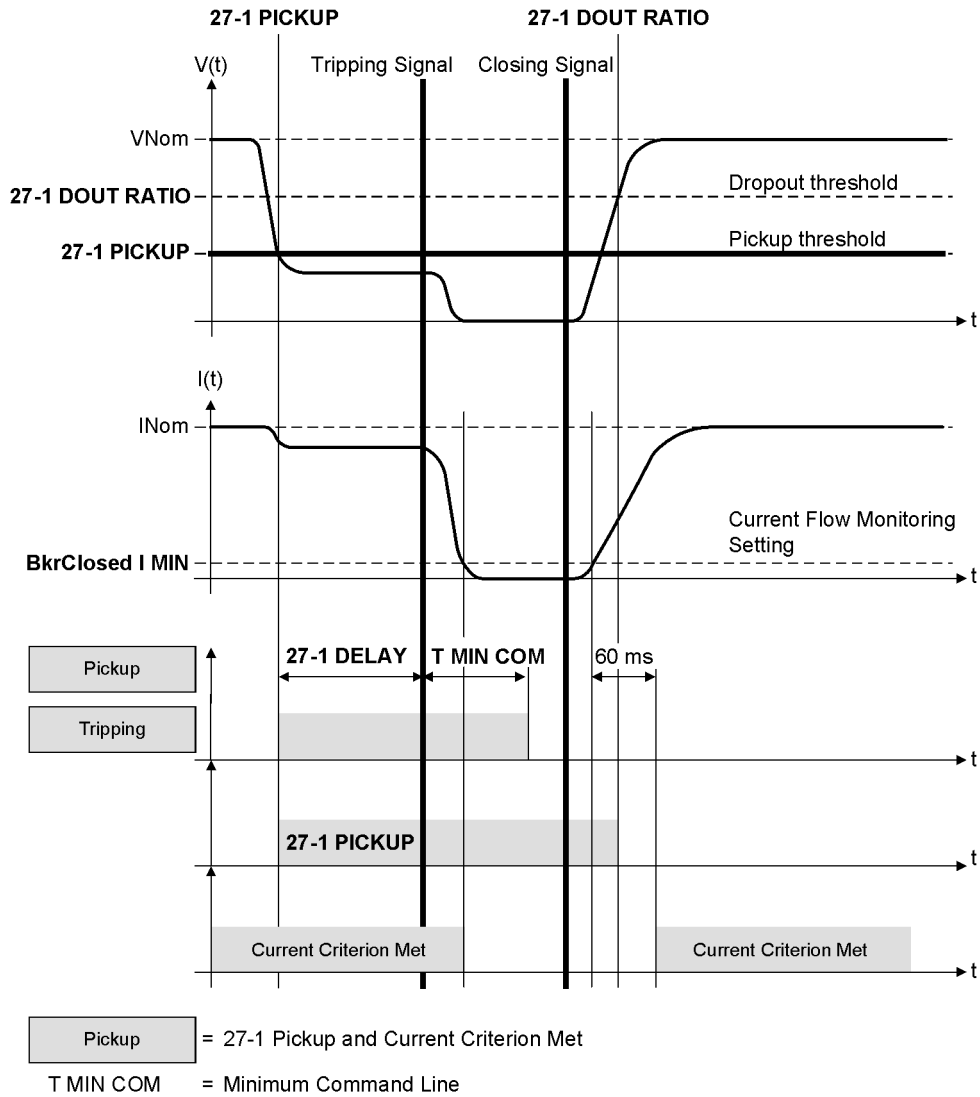

Figure 2-48 Typical fault profile for load side connection of the voltage transformers (with current supervision)

Upon the closing of the circuit breaker, current criterion is delayed for a short period of time. If the voltage criterion drops out during this time period (about 60 ms), the protection function does not pick up. Therefore no fault record is created when voltage protection is activated in a healthy system. It is important to understand, however, that if a low voltage condition exists on the load after the circuit breaker is closed (unlike Figure 2-48), the desired pickup of the element will be delayed by 60 ms.

The following figure shows the logic diagram of the undervoltage protection function.

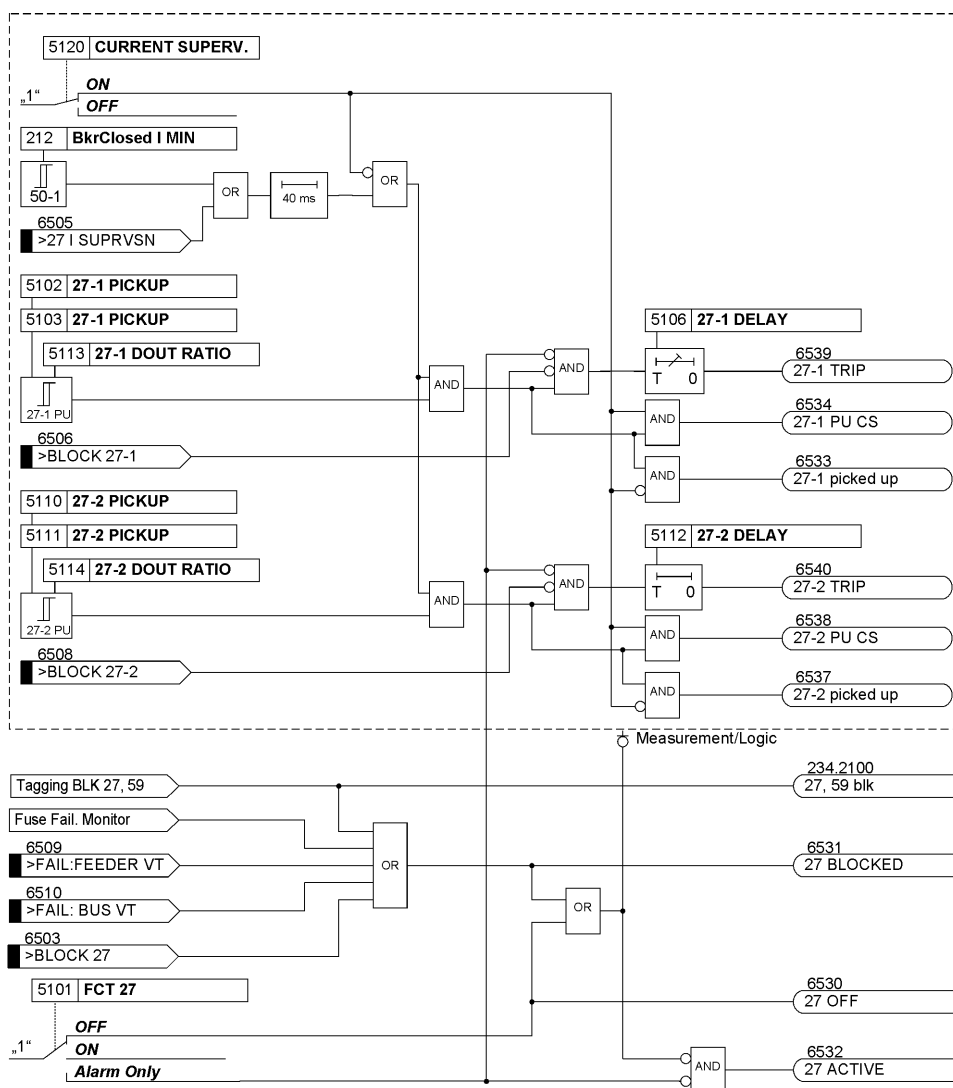

Figure 2-49 Logic diagram of the undervoltage protection

2.6.1.4 Setting Notes

General

Voltage protection is only effective and accessible if address 150 **27 / 59** is set to **Enabled** during configuration of protection functions. If this function is not required, then **Disabled** is set.

The voltage to be evaluated is selected in **Power System Data 1** (see Chapter 2.6, Table 2-9).

Overvoltage protection can be turned **ON** or **OFF**, or set to **Alarm Only** at address 5001 **FCT 59**.

Undervoltage protection can be turned **ON** or **OFF** or set to **Alarm Only** at address 5101 **FCT 27**.

With the protection function **ON**, tripping, the clearing of a fault and fault recording are initiated when the thresholds are exceeded and the set time delays have expired.

With setting **Alarm Only** no trip command is given, no fault is recorded and no immediate fault annunciation is shown on the display.

Overvoltage Protection with Phase-to-phase or Phase-to-Ground Voltages

The largest of the applied voltages is evaluated for the phase-to-phase or phase-to-Ground overvoltage protection.

The threshold values are set in the value to be evaluated (see Chapter 2.6, Table 2-9).

The overvoltage protection has two elements. The pickup value of the lower threshold (address 5002 or 5003, **59-1 PICKUP**, depending on the phase-to-Ground or the phase-to-phase voltages, can be assigned a longer time delay (address 5004, **59-1 DELAY**) and the upper threshold Element (address 5005 or 5006, **59-2 PICKUP**) a shorter (address 5007, **59-2 DELAY**) time delay. There are no specific procedures on how the pickup values are set. However, as the function is mainly used to prevent high insulation damage to system components and users, the threshold value 5002, 5003 **59-1 PICKUP** lies generally between 110 % and 115 % of the nominal voltage and setting value 5005, 5006 **59-2 PICKUP** at approximately 130 %.

The time delays of the overvoltage elements are entered at addresses 5004 **59-1 DELAY** and 5007 **59-2 DELAY**, and should be selected in such manner that they make allowance for brief voltage peaks that are generated during switching operations and also enable clearance of stationary overvoltages in due time.

The choice between phase-to-Ground and phase-to-phase voltage allows voltage asymmetries (e.g. caused by a ground fault) to be taken into account (phase-to-Ground) or to remain unconsidered (phase-to-phase) during evaluation.

Overvoltage Protection - Positive Sequence System V1

In a three-phase voltage transformer connection the positive sequence system can be evaluated for the overvoltage protection by means of configuring parameter 614 **OP. QUANTITY 59** to **V1**. In this case, the threshold values of the overvoltage protection must be set in parameters 5019 **59-1 PICKUP V1** or 5020 **59-2 PICKUP V1**.

Overvoltage Protection - Negative Sequence System V2

In a three-phase transformer connection, parameter 614 **OP. QUANTITY 59** can determine that the negative sequence system **V2** can be evaluated as a measured value for the overvoltage protection. The negative sequence system detects voltage unbalance and can be used for the stabilization of the time overcurrent protection. In backup protection of transformers or generators, the fault currents lie, in some cases, only slightly above the load currents. In order to obtain a pickup threshold of the time overcurrent protection that is as sensitive as possible, its stabilization via the voltage protection is necessary to avoid false tripping.

Overtoltage protection comprises two elements. Thus, with configuration of the negative system, a longer time delay (address 5004, **59-1 DELAY**) may be assigned to the lower Element (address 5015, **59-1 PICKUP V2**) and a shorter time delay (address 5007, **59-2 DELAY**) may be assigned to the upper Element (address 5016, **59-2 PICKUP V2**). There are not clear cut procedures on how to set the pickup values **59-1 PICKUP V2** or **59-2 PICKUP V2** as they depend on the respective station configuration.

The time delays of the overvoltage elements are entered at addresses 5004 **59-1 DELAY** and 5007 **59-2 DELAY**, and should be selected in such manner that they make allowance for brief voltage peaks that are generated during switching operations and also enable clearance of stationary overvoltages in due time.

Dropout Threshold of the Overtoltage Protection

The dropout thresholds of the 59-1 Element and the 59-2 Element can be configured via the dropout ratio $r = V_{\text{Dropout}}/V_{\text{Pickup}}$ at addresses 5017 **59-1 DOUT RATIO** or 5018 **59-2 DOUT RATIO**. The following marginal condition applies to r :

$r \cdot (\text{configured pickup threshold}) \leq 150 \text{ V}$ with connection of phase-to-phase voltages and phase-to-Ground voltages or

$r \cdot (\text{configured pickup threshold}) \leq 260 \text{ V}$ with calculation of the measured values from the connected voltages (e.g. phase-to-phase voltages calculated from the connected phase-to-Ground voltages).

The minimum hysteresis is 1.0 V.

Undervoltage Protection - Positive Sequence System V1

The positive sequence component (**V1**) can be evaluated for the undervoltage protection. Especially in case of stability problems, their acquisition is advantageous because the positive sequence system is relevant for the limit of the stable energy transmission. Concerning the pickup values there are no specific notes on how to set them. However, because the undervoltage protection function is primarily intended to protect induction machines from voltage dips and to prevent stability problems, the pickup values will usually be between 60 % and 85 % of the nominal voltage.

The threshold value is multiplied as positive sequence voltage and set to $\sqrt{3}$, thus realizing the reference to the nominal voltage.

Undervoltage protection comprises two elements. The pickup value of the lower threshold is set at address 5110 or 5111, **27-2 PICKUP** (depending on the voltage transformer connection, phase-to-Ground or phase-to-phase), while time delay is set at address 5112, **27-2 DELAY** (short time delay). The pickup value of the upper Element is set at address 5102 or 5103, **27-1 PICKUP**, while the time delay is set at address 5106, **27-1 DELAY** (a somewhat longer time delay). Setting these elements in this way allows the undervoltage protection function to closely follow the stability behavior of the system.

The time settings should be selected such that tripping occurs in response to voltage dips that lead to unstable operating conditions. On the other hand, the time delay should be long enough to avoid tripping on short-term voltage dips.

Undervoltage Protection with Phase-to-phase or Phase-to-Ground Voltages

In parameter 615 **OP. QUANTITY 27** you can determine for undervoltage protection in a three-phase connection that instead of the positive-sequence system **V1**, the smallest of the phase-to-phase voltages **Vphph** or the smallest phase-to-Ground voltage **Vph-n** is configured as a measured quantity. The threshold values are set in the quantity to be evaluated (see Section 2.6, table 2-9).

Undervoltage protection comprises two elements. The pickup value of the lower threshold is set at address 5110 or 5111, **27-2 PICKUP** (depending on the voltage transformer connection, phase-to-Ground or phase-to-phase), while time delay is set at address 5112, **27-2 DELAY** (short time delay). The pickup value of the upper Element is set at address 5102 or 5103, **27-1 PICKUP**, while the time delay is set at address 5106, **27-1 DELAY** (a somewhat longer time delay). Setting these elements in this way allows the undervoltage protection function to closely follow the stability behavior of the system.

The time settings should be selected such that tripping occurs in response to voltage dips that lead to unstable operating conditions. On the other hand, the time delay should be long enough to avoid tripping on short-term voltage dips.

Dropout threshold of the undervoltage protection

The dropout thresholds of the 27-1 Element and the 27-2 Element can be configured via the dropout ratio $r = V_{\text{Dropout}}/V_{\text{Pickup}}$ at addresses 5113 **27-1 DOUT RATIO** or 5114 **27-2 DOUT RATIO**. The following marginal condition applies to r :

$r \cdot$ (configured pickup threshold) \leq 130 V of instantaneously measured voltages (phase-to-phase voltages or phase-to-ground voltages) or

$r \cdot$ (configured pickup threshold) \leq 225 V for evaluation of values calculated from measured voltages (e.g. calculated phase-to-phase voltages from the connected phase-to-ground voltages).

The minimum hysteresis is 1.0 V.



Note

If a setting is accidentally selected so that the dropout threshold (= pickup threshold · dropout ratio) results in a value greater than 130 V/225 V, it will be limited automatically. No error message occurs.

Current Criterion for Undervoltage Protection

The 27-1 Element and the 27-2 Element can be supervised by the current flow monitoring setting. If the **CURRENT SUPERV.** is switched ON at address 5120 (factory setting), the release condition of the current criterion must be fulfilled in addition to the corresponding undervoltage condition, which means that a configured minimum current (**BkrClosed I MIN**, address 212) must be present to make sure that this protective function can pick up. Thus it can be achieved that pickup of the undervoltage protection drops out when the line is disconnected from voltage supply. Furthermore, this feature prevents an immediate general pickup of the device when the device is powered-up without measurement voltage being present.



Note

If parameter **CURRENT SUPERV.** is set to disabled at address 5120, the device picks up immediately if the measuring-circuit voltage fails and the undervoltage protection is enabled. Furthermore, configuration can be performed by pickup of measuring-circuit voltage or blocking of the voltage protection. The latter can be initiated via device operation in DIGSI and via communication from the control center by means of a tagging command for blocking the voltage protection. This causes the dropout of the pickup and parameterization can be resumed.

Please note that the pickup threshold **BkrClosed I MIN** (address 212) also affects the overload protection, the cold load pickup function and the CB maintenance.

2.6.1.5 Settings

Addresses which have an appended "A" can only be changed with DIGSI, under "Display Additional Settings".

Addr.	Parameter	Setting Options	Default Setting	Comments
5001	FCT 59	OFF ON Alarm Only	OFF	59 Overvoltage Protection
5002	59-1 PICKUP	20 .. 260 V	110 V	59-1 Pickup
5003	59-1 PICKUP	20 .. 150 V	110 V	59-1 Pickup
5004	59-1 DELAY	0.00 .. 100.00 sec; ∞	0.50 sec	59-1 Time Delay
5005	59-2 PICKUP	20 .. 260 V	120 V	59-2 Pickup
5006	59-2 PICKUP	20 .. 150 V	120 V	59-2 Pickup
5007	59-2 DELAY	0.00 .. 100.00 sec; ∞	0.50 sec	59-2 Time Delay
5015	59-1 PICKUP V2	2 .. 150 V	30 V	59-1 Pickup V2
5016	59-2 PICKUP V2	2 .. 150 V	50 V	59-2 Pickup V2
5017A	59-1 DOUT RATIO	0.90 .. 0.99	0.95	59-1 Dropout Ratio
5018A	59-2 DOUT RATIO	0.90 .. 0.99	0.95	59-2 Dropout Ratio
5019	59-1 PICKUP V1	20 .. 150 V	110 V	59-1 Pickup V1
5020	59-2 PICKUP V1	20 .. 150 V	120 V	59-2 Pickup V1
5101	FCT 27	OFF ON Alarm Only	OFF	27 Undervoltage Protection
5102	27-1 PICKUP	10 .. 210 V	75 V	27-1 Pickup
5103	27-1 PICKUP	10 .. 120 V	45 V	27-1 Pickup
5106	27-1 DELAY	0.00 .. 100.00 sec; ∞	1.50 sec	27-1 Time Delay
5110	27-2 PICKUP	10 .. 210 V	70 V	27-2 Pickup
5111	27-2 PICKUP	10 .. 120 V	40 V	27-2 Pickup
5112	27-2 DELAY	0.00 .. 100.00 sec; ∞	0.50 sec	27-2 Time Delay
5113A	27-1 DOUT RATIO	1.01 .. 3.00	1.20	27-1 Dropout Ratio
5114A	27-2 DOUT RATIO	1.01 .. 3.00	1.20	27-2 Dropout Ratio
5120A	CURRENT SUPERV.	OFF ON	ON	Current Supervision

2.6.1.6 Information List

No.	Information	Type of Information	Comments
234.2100	27, 59 blk	IntSP	27, 59 blocked via operation
6503	>BLOCK 27	SP	>BLOCK 27 undervoltage protection
6505	>27 I SUPRVSN	SP	>27-Switch current supervision ON
6506	>BLOCK 27-1	SP	>BLOCK 27-1 Undervoltage protection
6508	>BLOCK 27-2	SP	>BLOCK 27-2 Undervoltage protection
6513	>BLOCK 59	SP	>BLOCK 59 overvoltage protection
6530	27 OFF	OUT	27 Undervoltage protection switched OFF
6531	27 BLOCKED	OUT	27 Undervoltage protection is BLOCKED
6532	27 ACTIVE	OUT	27 Undervoltage protection is ACTIVE

No.	Information	Type of Information	Comments
6533	27-1 picked up	OUT	27-1 Undervoltage picked up
6534	27-1 PU CS	OUT	27-1 Undervoltage PICKUP w/curr. superv
6537	27-2 picked up	OUT	27-2 Undervoltage picked up
6538	27-2 PU CS	OUT	27-2 Undervoltage PICKUP w/curr. superv
6539	27-1 TRIP	OUT	27-1 Undervoltage TRIP
6540	27-2 TRIP	OUT	27-2 Undervoltage TRIP
6565	59 OFF	OUT	59-Overvoltage protection switched OFF
6566	59 BLOCKED	OUT	59-Overvoltage protection is BLOCKED
6567	59 ACTIVE	OUT	59-Overvoltage protection is ACTIVE
6568	59-1 picked up	OUT	59-1 Overvoltage V> picked up
6570	59-1 TRIP	OUT	59-1 Overvoltage V> TRIP
6571	59-2 picked up	OUT	59-2 Overvoltage V>> picked up
6573	59-2 TRIP	OUT	59-2 Overvoltage V>> TRIP

2.6.2 Voltage protection (CEI 0-16 standard)

2.6.2.1 Measurement Principle

Connection

If position 14 of MLFB is chosen as G : CEI 0-16 PI funct. (27/59/59V0/81/81V), the following topology as described in the standard applies.

Please refer to CEI 0-16 Standard for further details. Figure 2-50 shows the primary main wiring of application.

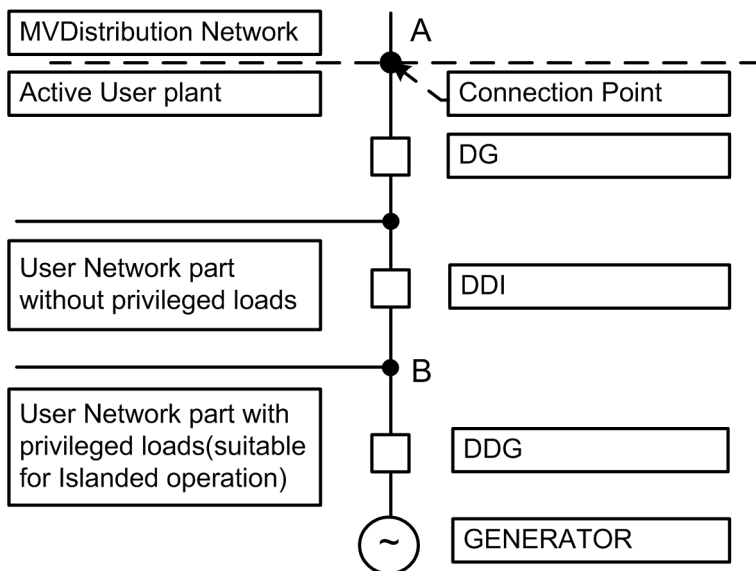

Figure 2-50 Primary main wiring of application

DG, DDI, DDG are circuit breakers. DG and DDI may be combined into one circuit breaker.

VTs can be either connected upstream or downstream the DDI.

If the standard inductive voltage transformers are used, only a ph-ph voltage connection is allowed to measure phase voltages and frequencies. The ground voltage V_{Gnd} must be measured only with a broken delta winding according to the standard.

With reference to the VT's position, to accomplish with CEI 0-16 statements, some parameters and some signals must be used. Refer to the following pictures and relevant descriptions for further details.

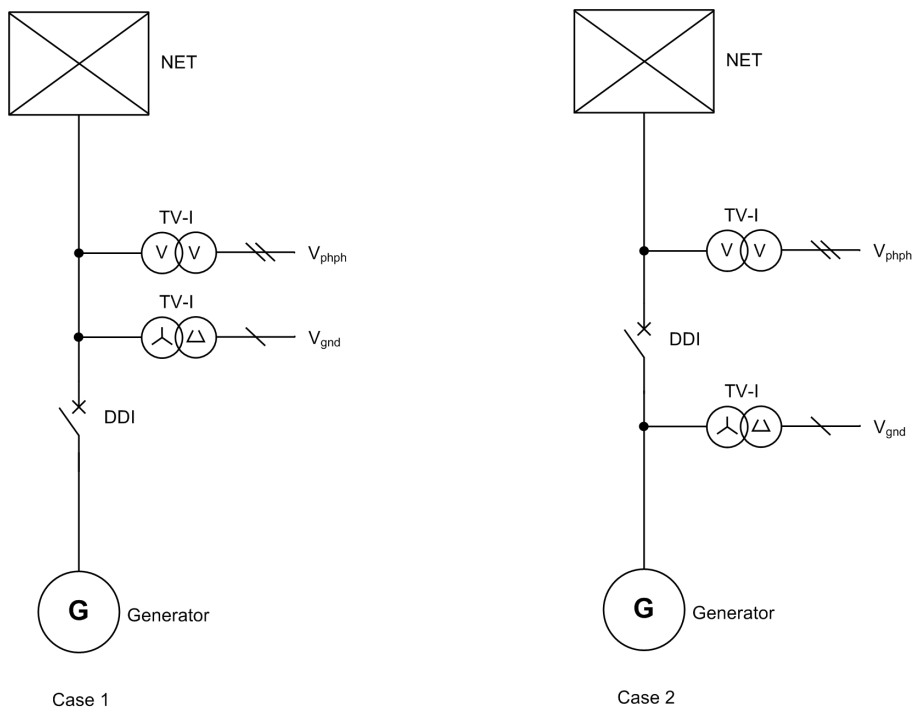

Figure 2-51 Application guide of VT installation position: Case 1 and Case 2

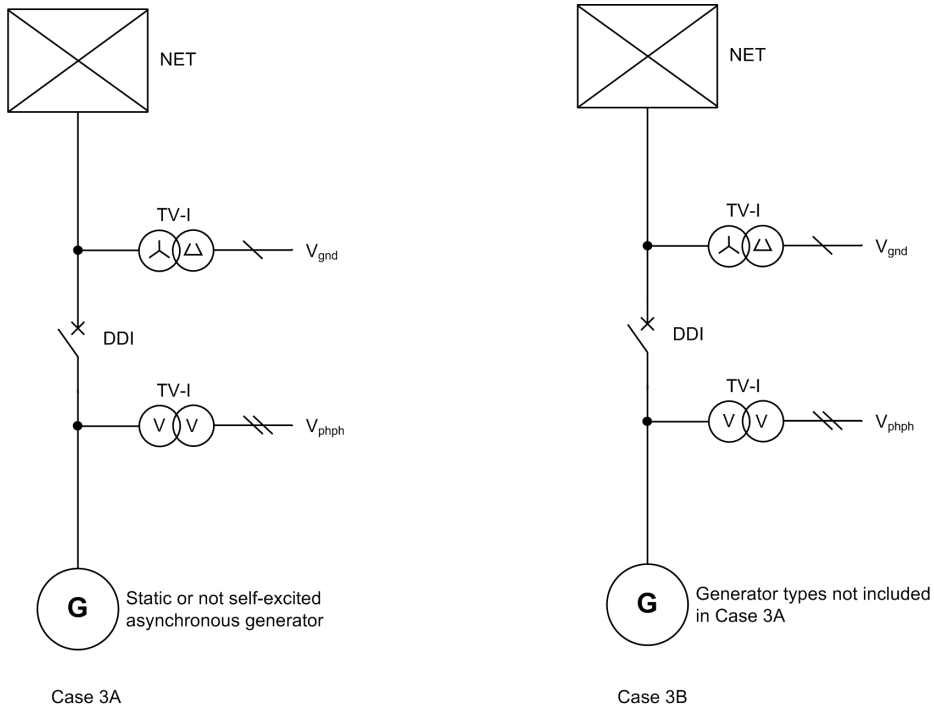

Figure 2-52 Application guide of VT installation position: Case 3

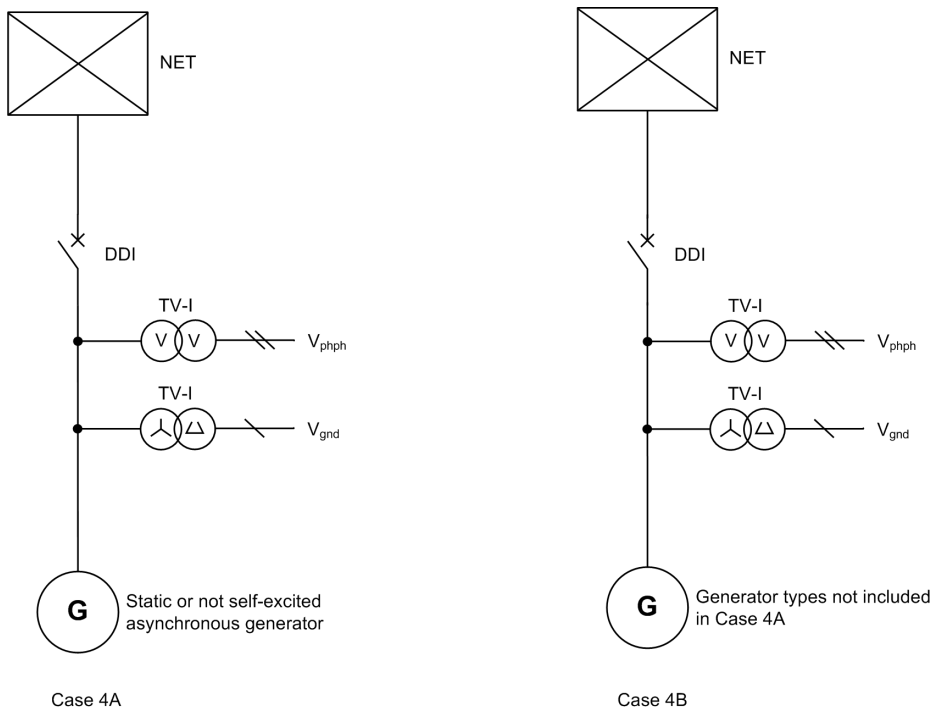

Figure 2-53 Application guide of VT installation position: Case 4

For different VT installation positions, the usage of 7SJ80 CEI 0-16 signals ">DDI Open", ">Manual Close" and of the parameter 616 is different, application guide is:

Case 1: Use neither ">Manual Close" nor ">DDI open" signals.

Case 2: According to CEI 0-16 ">Manual Close" must be used to indicate the intentional closing command of the DDI. ">DDI Open" must not be used.

Case 3A: According to CEI 0-16 ">DDI Open" must be used to indicate the state of the DDI. ">Manual Close" must not be used.

Parameter 616 **STATIC GEN.** must be set to *YES*.

Case 3B: According to CEI 0-16 ">DDI Open" must be used to indicate the state of the DDI. ">Manual Close" must not be used.

Parameter 616 **STATIC GEN.** must be set to *NO*.

Case 4A: According to CEI-016 both signals ">Manual Close" and ">DDI Open" must be used. Also parameter 616 must be used.

Parameter 616 **STATIC GEN.** must be set to *YES*.

Case 4B: According to CEI-016 both signals ">Manual Close" and ">DDI Open" must be used. Also parameter 616 must be used.

Parameter 616 **STATIC GEN.** must be set to *NO*.

All the PI functions can be blocked by ">DDI Open", for detail feature of ">Manual Close" and ">DDI Open", refer to chapter 2.8.2.1 (Accelerated Feature).

Measurement Values

The voltages supplied to the device should correspond the two phase-to-phase voltages (V_{A-B} , V_{B-C}) and the displacement voltage (ground voltage V_N).

The following table indicates which voltages can be evaluated by the function. The settings for this are made in the **P.System Data 1**. Furthermore, it is indicated to which value the threshold must be set. All voltages are fundamental frequency values

Table 2-10 Voltage protection, selectable voltages

Funtion	Connection, three-phase (parameter 213)	Selectable voltage (parameter 614/615)	Threshold to be set as
Overvoltage	Vab, Vbc, VGnd	Vphph (largest phase-to-phase voltage)	Phase-to-phase voltage
Undervoltage	Vab, Vbc, VGnd	Vphph (smallest phase-to-phase voltage)	Phase-to-phase voltage

2.6.2.2 Overvoltage Protection 59

Function

CEI 0-16 PI protection function aim is always to disconnect the plant in case of fault in the MV network.

The overvoltage protection has two elements, 59.S1 and 59.S2.

For 59.S1, 10 minutes (600s) RMS value is used as detection quantity, the new average value of the previous 10 minutes is updated every 3 s. The operation time is 3 seconds (fixed value).

For 59.S2, fundamental component of phase-phase voltage is used as detection quantity, it has one adjustable operation time

The settings required by CEI 0-16 are operation times, not as usual, mere delay times. Operating time means, that also the pick up time of the respective protection function and the operating time of the tripping contact is already included.

Operation time = Inherent pickup time + time delay + binary output response time

When one of the adjustable settings is exceeded, the 59 element picks up and trip signal will come after an operation time has elapsed. The operation time is not dependent on the magnitude of the overvoltage.

The dropout ratio for the two overvoltage elements ($= V_{\text{Dropout value}} / V_{\text{Pickup value}}$) can be set.

The following figure shows the logic diagram of the overvoltage protection function.

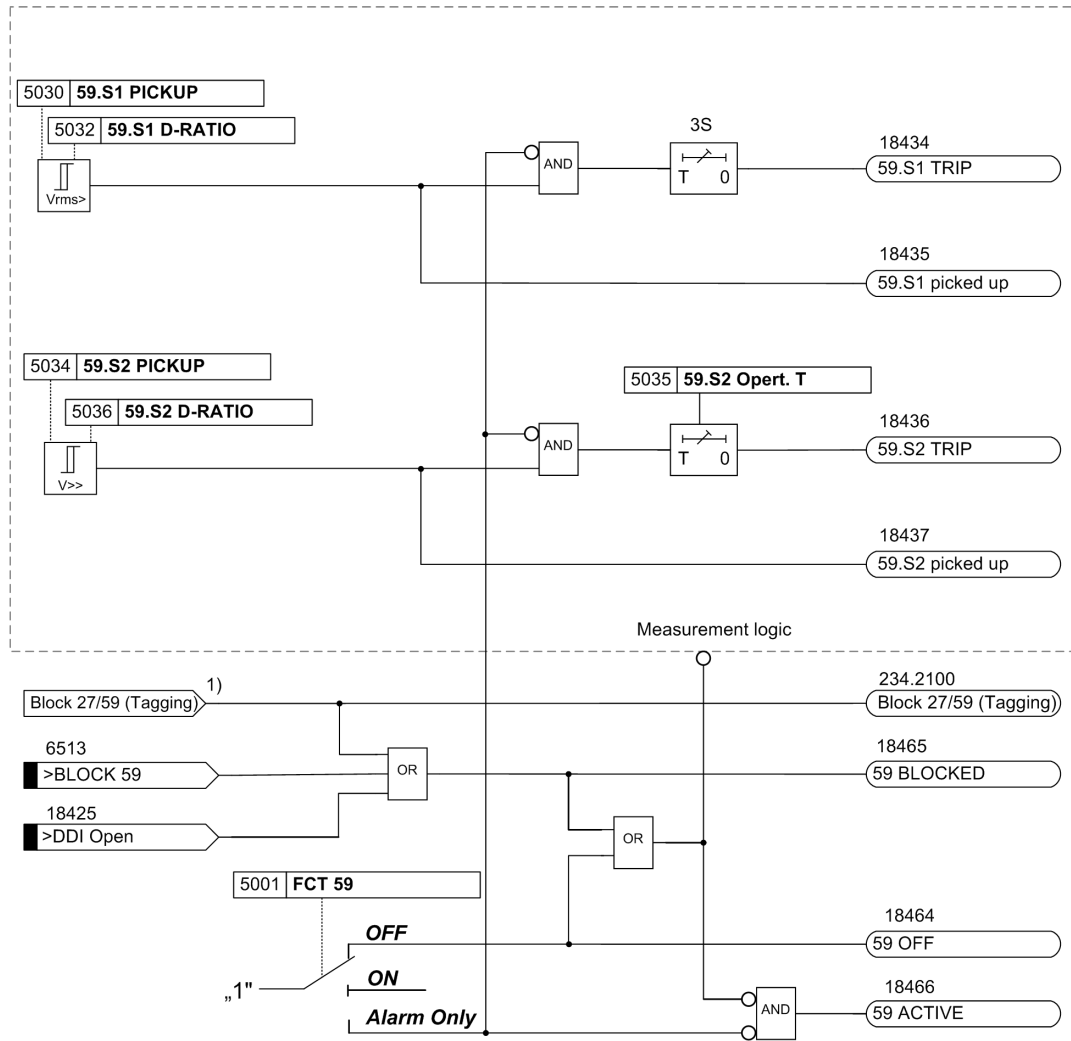

1) Tagging means control of this function by DIGSI- or station-command.

Figure 2-54 Logic diagram of the overvoltage protection

2.6.2.3 Undervoltage Protection 27

Function

CEI 0-16 PI protection function aim is always to disconnect the plant in case of fault in the MV network.

Undervoltage protection consists of two definite time elements (**27.S1 PICKUP** and **27.S2 PICKUP**). Therefore, tripping can be time-coordinated depending on how severe voltage collapses are. Voltage thresholds and time delays can be set individually for both elements.

The dropout ratio for the two undervoltage elements ($= V_{\text{dropout value}}/V_{\text{pickup value}}$) can be set.

Figure 2-55 shows a typical voltage profile during a fault for network side connection of the voltage transformers (If voltage transformers are connected with this situation, binary input signal **18425 ">DDI Open"** must not be configured in matrix). After the voltage has dropped below the pickup setting, tripping signal will come after an operation time **27.S1 Operation Time**. As long as the voltage remains below the dropout setting, reclosing is blocked. Only after the fault has been cleared, i.e. when the voltage increases above the dropout level, the element drops out and allows reclosing of the circuit breaker.

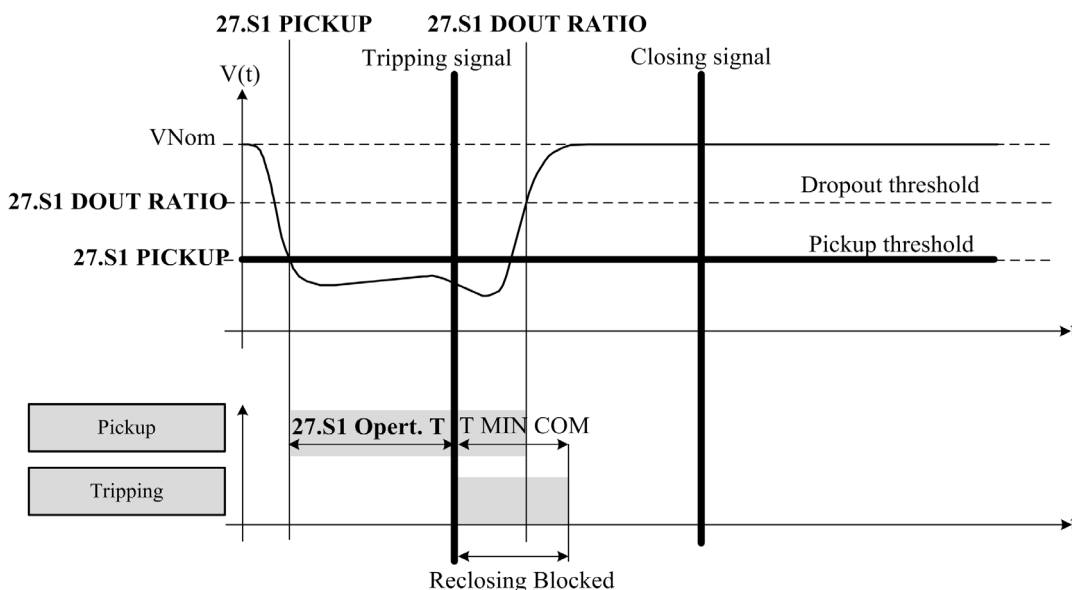

T MIN COM = Minimum Command Line

Figure 2-55 Typical fault profile for network side connection of the ph-ph voltage transformer

Figure 2-56 shows a fault profile for a user side connection of the voltage transformers (ph-ph VTs which are for frequency/voltage measurements). In this case, binary input signal **18425 ">DDI Open"** should be configured in matrix and connected with circuit breaker open status mandatorily. When the circuit breaker is open, the voltage disappears (**user side fault, the voltage remains below the pickup setting**), and **DDI open** signal can be used that the undervoltage protection resets. The related trip signal will reset after the minimum trip command duration (**0210A Minimum TRIP Command Duration**).

After the voltage has dropped below the pickup setting, tripping signal will come after operation time **27.S1 Operation Time**. When the circuit breaker opens, voltage decreases to zero but **DDI Open** signal can block undervoltage protection. Pickup of the protection function is also reset by the **DDI Open**. As a consequence, energization is admitted anew when the minimum command time elapsed.

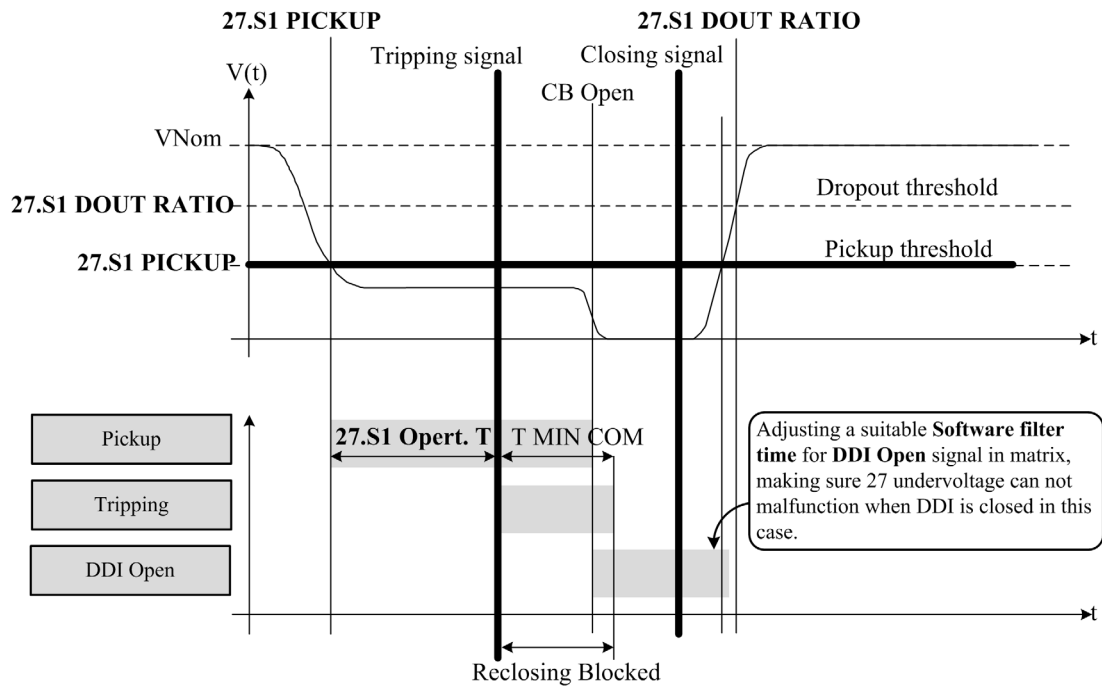

T MIN COM = Minimum Command Line

Figure 2-56 Typical fault(user side fault) profile for user side connection of the voltage transformers

If source fault occurs for user side connection of the voltage transformers (ph-ph VTs or 3 ph-g VTs, which are for frequency/voltage measurements, not include the open delta VTs), profile is shown in Figure 2-57.

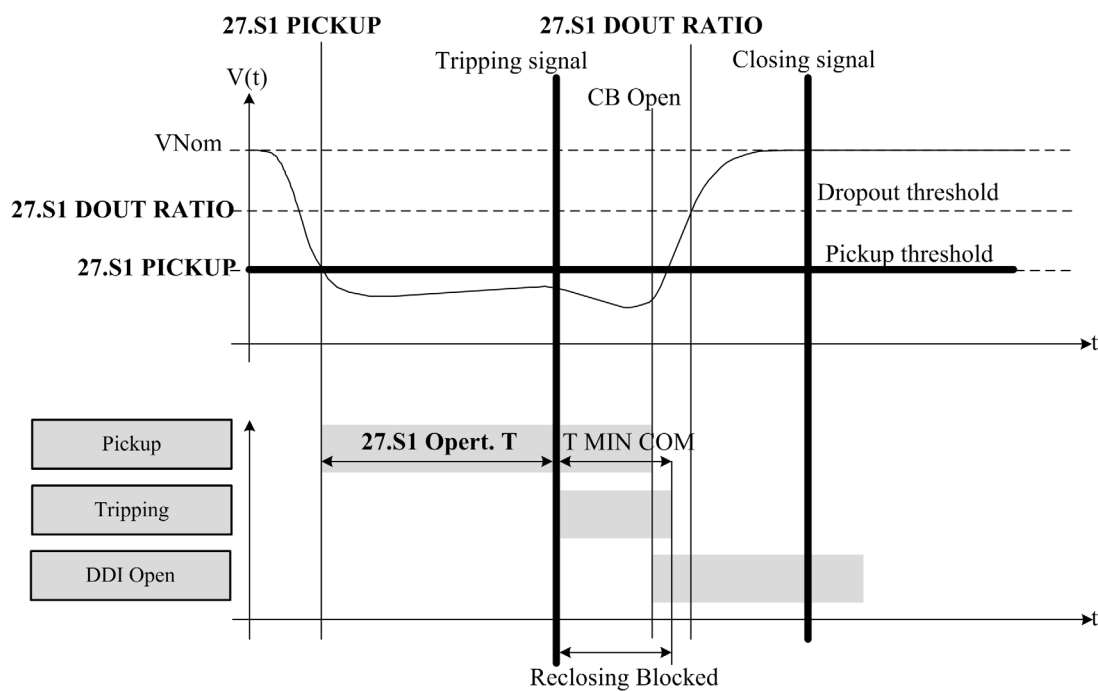

T MIN COM = Minimum Command Line

Figure 2-57 Typical fault (source side fault) profile for user side connection of the voltage transformers

The following figure shows the logic diagram of the undervoltage protection function.

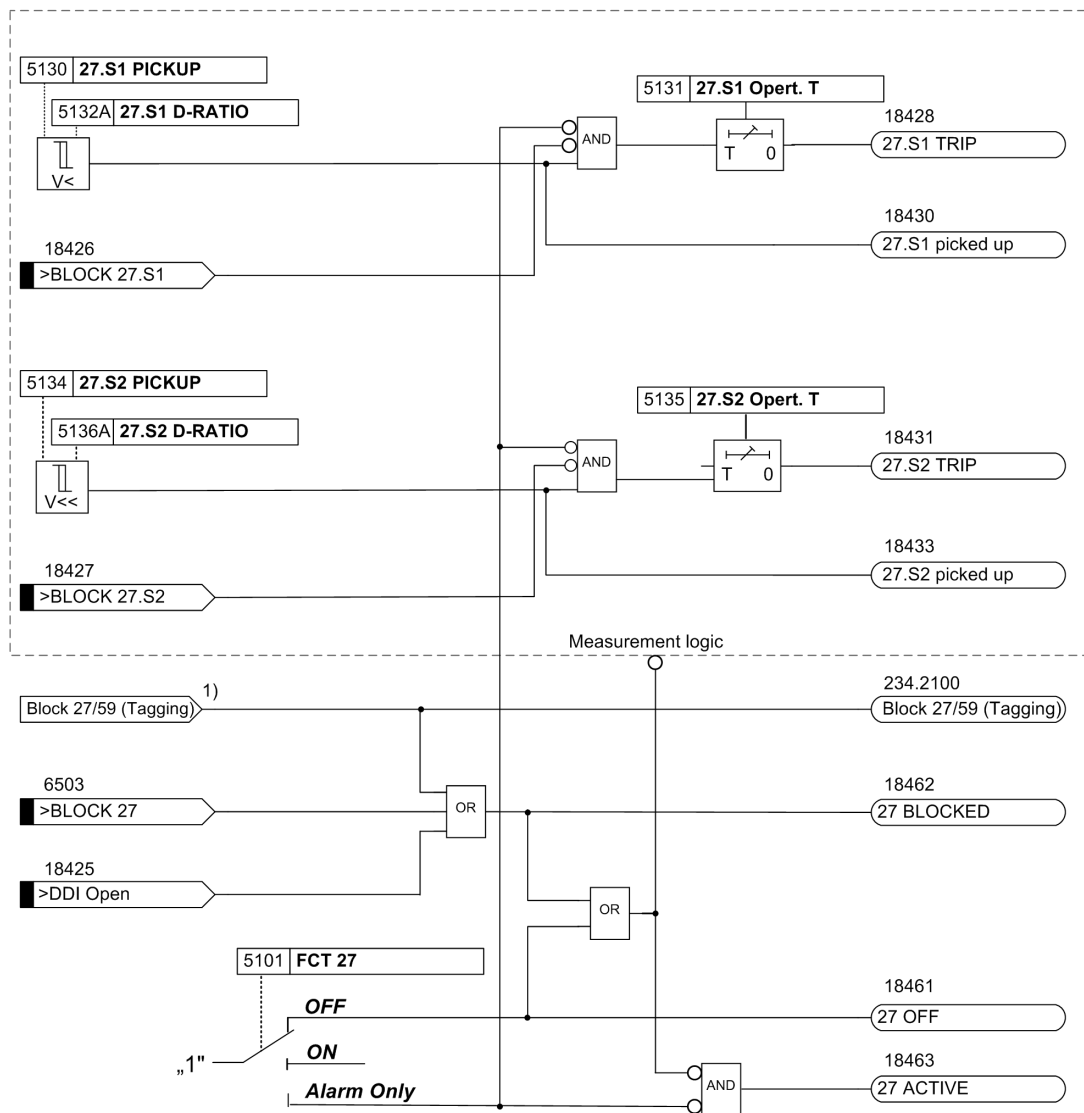

1) Tagging means control of this function by DIGSI- or station-command.

Figure 2-58 Logic diagram of the undervoltage protection

2.6.2.4 Setting Notes

General

Voltage protection is only effective and accessible if address 150 **27/59** is set to **Enabled** during configuration of protection functions. If this function is not required, then **Disabled** is set.

Overvoltage protection can be turned **ON** or **OFF**, or set to **Alarm Only** at address 5001 **FCT 59**.

Undervoltage protection can be turned **ON** or **OFF** or set to **Alarm Only** at address 5101 **FCT 27**.

With the protection function **ON**, tripping, the clearing of a fault and fault recording are initiated when the thresholds are exceeded and the set operation times have expired.

With setting **Alarm Only** no trip command is given, no fault is recorded and no immediate fault annunciation is shown on the display.

All default settings are as described in the CEI 0-16 standard.

Overvoltage Protection with Phase-to-phase Voltage

The applied voltages are evaluated for the phase-to-phase overvoltage protection.

The overvoltage protection has two elements. The pickup value of the lower threshold (address 5030, **59.S1 PICKUP**), depending on the phase-to-phase voltages with a 3 seconds constant operation time and the upper threshold element (address 5034, **59.S2 PICKUP**) with a shorter (address 5035, **59.S2 Operation Time**) operation time. There are no specific procedures on how the pickup values are set. However, as the function is mainly used to prevent high insulation damage to system components and users, the threshold value 5030 **59.S1 PICKUP** lies generally between 110 % and 115 % of the nominal voltage and setting value 5034 **59-2 PICKUP** at approximately 120 %.

The operation time of the overvoltage element is entered at address 5035 **59.S2 Operation Time**, and should be selected in such manner that it make allowance for brief voltage peaks that are generated during switching operations and also enable clearance of stationary overvoltage in due time.

Dropout Threshold of the Overvoltage Protection

The dropout thresholds of the 59.S1 Element and the 59.S2 Element can be configured via the dropout ratio $r = V_{\text{Dropout}}/V_{\text{Pickup}}$ at addresses 5032 **59.S1 DOUT RATIO** or 5036 **59.S2 DOUT RATIO**. The following marginal condition applies to r:

$r \cdot (\text{configured pickup threshold}) \leq 150 \text{ V}$ with connection of phase-to-phase voltages.

The minimum hysteresis is 1.0 V.

Undervoltage Protection with Phase-to-phase Voltage

Undervoltage protection comprises two elements. The pickup value of the lower threshold is set at address 5134, **27.S2 PICKUP**, while operation time is set at address 5135, **27.S2 Operation Time** (short time delay). The pickup value of the upper Element is set at address 5130, **27.S1 PICKUP**, while the operation time is set at address 5131, **27.S1 Operation Time** (a somewhat longer time delay). Setting these elements in this way allows the undervoltage protection function to closely follow the stability behavior of the system.

The time settings should be selected such that tripping occurs in response to voltage dips that lead to unstable operating conditions. On the other hand, the time delay should be long enough to avoid tripping on short-term voltage dips.

Dropout Threshold of the Undervoltage Protection

The dropout thresholds of the 27.S1 Element and the 27.S2 Element can be configured via the dropout ratio $r = V_{\text{dropout}} / V_{\text{pickup}}$ at addresses 5132 **27.S1 DOUT RATIO** or 5136 **27.S2 DOUT RATIO**. The following marginal condition applies to r :

$r \cdot (\text{configured pickup threshold}) \leq 130 \text{ V}$ of instantaneously measured voltages (phase-to-phase voltages)

The minimum hysteresis is 1.0 V.



Note

If a setting is accidentally selected so that the dropout threshold (= pickup threshold · dropout ratio) results in a value greater than 1.20Un, it will be limited automatically. No error message occurs.

2.6.2.5 Settings

Addresses which have an appended "A" can only be changed with DIGSI, under "Display Additional Settings".

Addr.	Parameter	Setting Options	Default Setting	Comments
5001	FCT 59	OFF ON Alarm Only	ON	59 Overvoltage Protection
5030	59.S1 PICKUP	0.20 .. 1.50 Un	1.10 Un	59.S1 Pickup
5034	59.S2 PICKUP	0.20 .. 1.50 Un	1.20 Un	59.S2 Pickup
5035	59.S2 Opert.T	0.05..100.00 sec; ∞	0.60 sec	59.S2 Operation Time
5032A	59 S1 D-RATIO	0.90..0.99	0.96	59.S1 Dropout Ratio
5036A	59.S2 D-RATIO	0.90..0.99	0.96	59.S2 Dropout Ratio
5101	FCT 27	OFF ON Alarm Only	ON	27 Undervoltage Protection
5130	27.S1 PICKUP	0.10..1.20 Un	0.85 Un	27.S1 Pickup
5131	27.S1 Opert T	0.05..100.00 sec; ∞	1.50 sec	27.S1 Operation Time
5134	27.S2 PICKUP	0.10..1.20 Un	0.30 Un	27.S2 Pickup
5135	27.S2 Opert.T	0.05..100.00 sec; ∞	0.20 sec	27.S2 Operation Time
5132A	27.S1 D-RATIO	1.01.. 3.00	1.04	27.S1 Dropout Ratio
5136A	27.S2 D-RATIO	1.01.. 3.00	1.04	27.S2 Dropout Ratio

2.6.2.6 Information List

No.	Information	Type of Information	Comments
234.2100	27, 59 blk	IntSP	27, 59 blocked via operation
6503	>BLOCK 27	SP	>BLOCK 27 undervoltage protection
18426	>BLOCK 27.S1	SP	>BLOCK 27.S1 undervoltage protection

No.	Information	Type of Information	Comments
18427	>BLOCK 27.S2	SP	>BLOCK 27.S2 Undervoltage protection
6513	>BLOCK 59	SP	>BLOCK 59 overvoltage protection
18461	27 OFF	OUT	27 Undervoltage protection switched OFF
18462	27 BLOCKED	OUT	27 Undervoltage protection is BLOCKED
18463	27 ACTIVE	OUT	27 Undervoltage protection is ACTIVE
18430	27.S1 picked up	OUT	27.S1 Undervoltage picked up
18428	27.S1 TRIP	OUT	27.S1 Undervoltage TRIP
18433	27.S2 picked up	OUT	27.S2 Undervoltage picked up
18431	27.S2 TRIP	OUT	27.S2 Undervoltage TRIP
18464	59 OFF	OUT	59-Overvoltage protection switched OFF
18465	59 BLOCKED	OUT	59-Overvoltage protection is BLOCKED
18466	59 ACTIVE	OUT	59-Overvoltage protection is ACTIVE
18435	59.S1 picked up	OUT	59.S1 Overvoltage picked up
18434	59.S1 TRIP	OUT	59.S1 Overvoltage TRIP
18437	59.S2 picked up	OUT	59.S2 Overvoltage picked up
18436	59.S2 TRIP	OUT	59.S2 Overvoltage TRIP

2.7 Negative Sequence Protection 46

Negative sequence protection detects unbalanced loads on the system.

Applications

- This protection function can be used to detect interruptions, short-circuits and polarity problems in the connections to the current transformers.
- It is also useful in detecting single-phase and two-phase faults with fault currents smaller than the maximum load current.

Prerequisites

The unbalanced load protection becomes effective when:
at least one phase current is greater than $0.05 \times I_{Nom}$ and
all phase currents are smaller than $10 \times I_{Nom}$.

2.7.1 Definite Time Characteristic

The definite time characteristic consists of two elements. As soon as the first settable threshold **46-1 PICKUP** is reached, a pickup message is output and time element **46-1 DELAY** is started. When the second Element **46-2 PICKUP** is started, another message is output and time element **46-2 DELAY** is initiated. Once either time delay elapses, a trip signal is initiated.

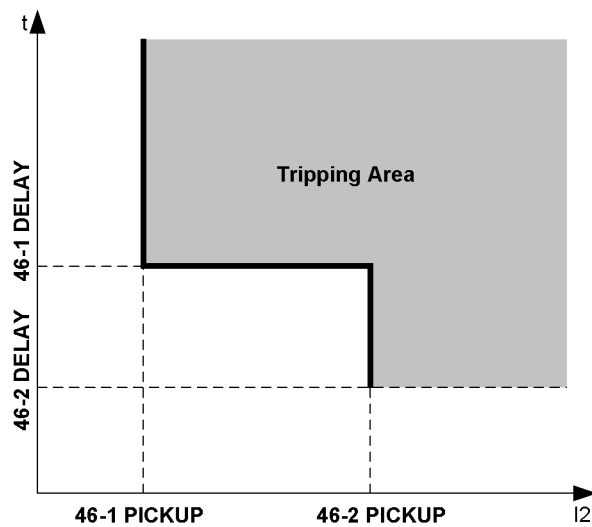

Figure 2-59 Definite time characteristic for negative sequence protection

Settable Dropout Times

Pickup stabilization for the definite-time tripping characteristic 46-1, 46-2 can be accomplished by means of settable dropout times. This facility is used in power systems with possible intermittent faults. Used together with electromechanical relays, it allows different dropout responses to be adjusted and a time grading of numerical and electromechanical relays to be implemented.

2.7.2 Inverse Time Characteristic 46-TOC

The inverse time Element is dependent on the ordered device version. It operates with IEC or ANSI characteristic tripping curves. The curves and associated formulas are given in the Technical Data. When programming the inverse time Curve also definite time elements **46-2 PICKUP** and **46-1 PICKUP** are available (see a foregoing paragraph).

Pickup and Tripping

The negative sequence current I_2 is compared to the setting value **46-TOC PICKUP**. When the negative sequence current exceeds 1.1 times the setting value, a pickup annunciation is generated. The tripping time is calculated from the negative sequence current according to the Curve selected. When tripping time is reached, a tripping command is issued. The characteristic curve is illustrated in the following Figure.

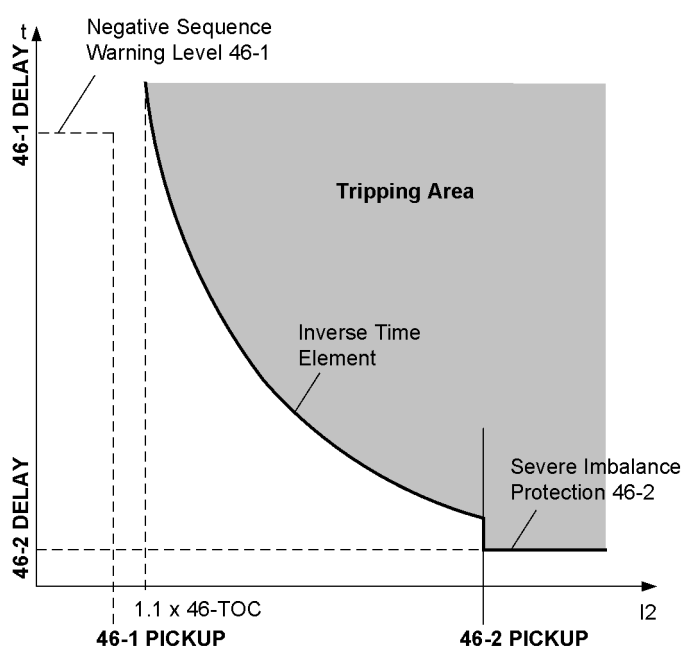

Figure 2-60 Inverse time characteristic for negative sequence protection

Dropout for IEC Curves

The Element drops out when the negative sequence current decreases to approx. 95% of the pickup setting. The time delay resets immediately to be ready for another pickup operation.

Dropout for ANSI Curves

When using an ANSI curve it can be selected whether the dropout of the element is to occur instantaneously or whether dropout is to be performed by means of the disk emulation mechanism. „Instantaneous“ means that the drop out will occur when a 95 % of the pickup value is reached. For a new pickup the time counter starts at zero.

The disk emulation evokes a dropout process (timer counter is decrementing) which begins after de-energization. This process corresponds to the reset of a Ferraris-disk (explaining its denomination "disk emulation"). In case several faults occur in succession, the "history" is taken into consideration due to the inertia of the Ferraris-disk, and the time response is adapted. This ensures a proper simulation of the temperature rise of the protected object even for extremely fluctuating unbalanced load values. Reset begins as soon as 90 % of the setting value is reached, in accordance with the dropout curve of the selected characteristic. In the range

between the dropout value (95 % of the pickup value) and 90 % of the setting value, the incrementing and decrementing process is in idle state.

Disk emulation offers advantages when the behavior of the negative sequence protection must be coordinated with other relays in the system based on electromagnetic measuring principles.

Logic

The following figure shows the logic diagram for the negative sequence protection function. The protection may be blocked via a binary input. This resets pickup and time elements and clears measured values.

When leaving the operating range of the unbalanced load protection (all phase currents below $0.05 \times I_{Nom}$ or at least one phase current is greater than $10 \times I_{Nom}$), all unbalanced load elements that have picked up will drop out.

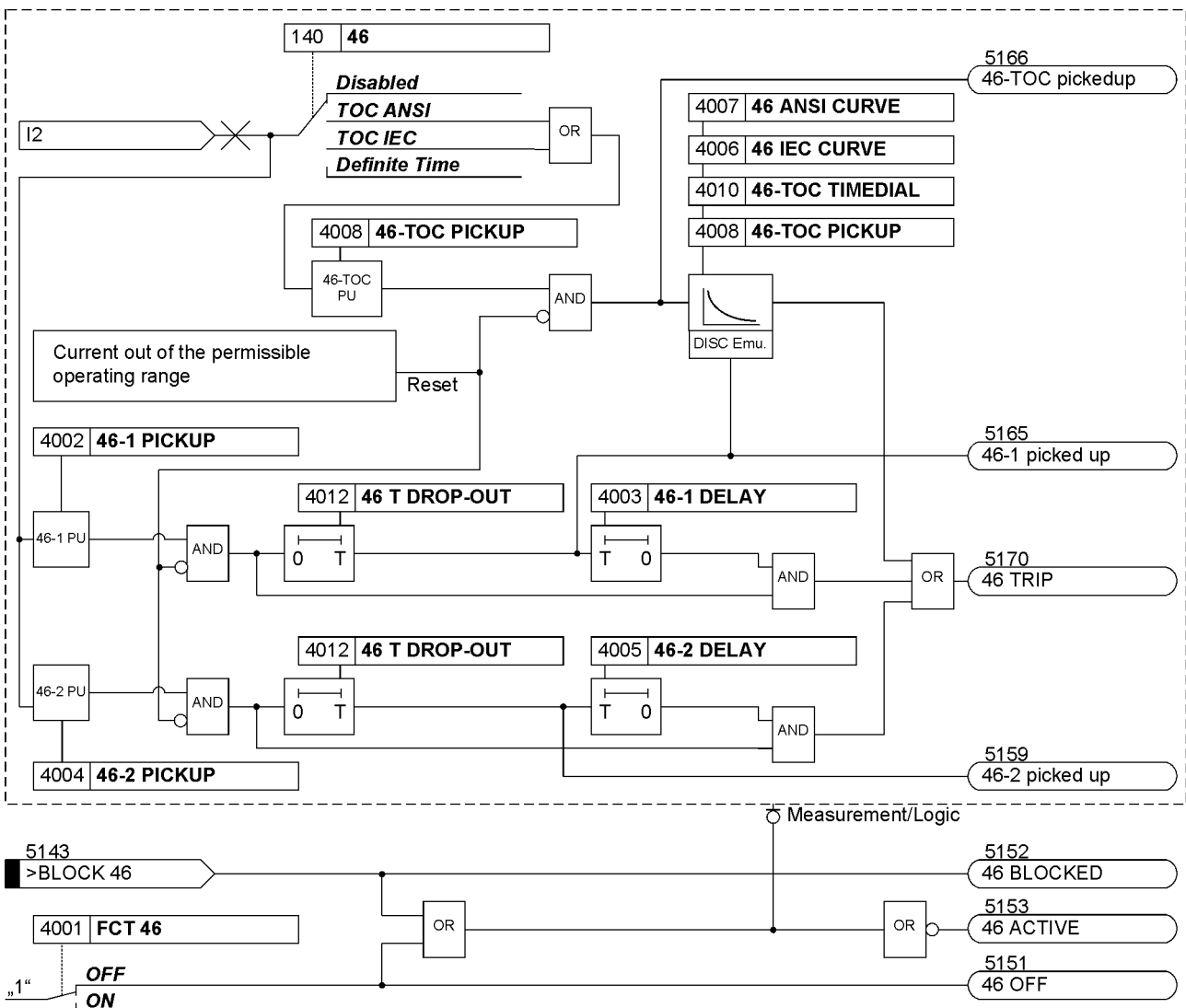

Figure 2-61 Logic diagram of the unbalanced load protection

The pickup of the definite time overcurrent protection can be stabilized by the configured dropout time 4012 **46 T DROP-OUT**. This time is started and maintains the pickup condition if the current falls below the threshold. Therefore, the function does not drop out at high speed. The trip command delay time continues running. After the dropout delay time has elapsed, the pickup is reported OFF and the trip delay time is reset unless the threshold has been exceeded again. If the threshold is exceeded again during the dropout delay time, the time is canceled. The trip command delay time continues running. Should the threshold value be exceeded after its expiry, the trip command is issued immediately. If the threshold value is not exceeded at this time, there will be no reaction. If the threshold value is exceeded again after expiry of the trip-command delay time, while the dropout delay time is still running, tripping occurs immediately.

The configured dropout times do not influence the tripping times of the inverse time elements as these depend dynamically on the measured current value. For purposes of dropout coordination, disc emulation is used with electro-mechanical relays.

2.7.3 Setting Notes

General

The function type has been specified during configuration of the protection functions (see Section 2.1.1.2, address 140, **46**). If only the definite time elements are desired, the address **46** should be set to **Definite Time**. Selecting **46 = TOC IEC** or **TOC ANSI** in address 140 will additionally make all parameters available that are relevant for the inverse time characteristics. If this function is not required, then **Disabled** is set.

The function can be turned **ON** or **OFF** in address 4001 **FCT 46**.

The default pickup settings and delay settings are generally sufficient for most applications.

Definite Time Elements

The unbalanced load protection function comprises two elements. Therefore, the upper Element (address 4004 **46-2 PICKUP**) can be set to a short time delay (address 4005 **46-2 DELAY**) and the lower Element (address 4002 **46-1 PICKUP**) can be set to a somewhat longer time delay (address 4003 **46-1 DELAY**). This allows the lower Element to act, e.g. as an alarm, while the upper Element will cut the inverse time Curve as soon as high inverse currents are present. If **46-2 PICKUP** is set to about 60%, tripping is always performed with the thermal Curve. On the other hand, with more than 60% of unbalanced load, a two-phase fault can be assumed. The delay time **46-2 DELAY** must be coordinated with the system grading of phase-to-phase faults. If power supply with current I is provided via just two phases, the following applies to the inverse current:

$$I_2 = \frac{1}{\sqrt{3}} \cdot I = 0.58 \cdot I$$

Examples:

When protecting feeder or cable systems, unbalanced load protection may serve to identify low magnitude unsymmetrical faults below the pickup values of the directional and non-directional overcurrent elements.

Here, the following must be observed:

$$I_2 = \frac{1}{\sqrt{3}} \cdot I = 0.58 \cdot I$$

A phase-to-ground fault with current I corresponds to the following negative sequence current:

$$I_2 = \frac{1}{3} \cdot I = 0.33 \cdot I$$

On the other hand, with more than 60% of unbalanced load, a phase-to-phase fault can be assumed. The delay time **46-2 DELAY** must be coordinated with the system grading of phase-to-phase faults.

For a power transformer, unbalanced load protection may be used as sensitive protection for low magnitude phase-to-ground and phase-to-phase faults. In particular, this application is well suited for delta-wye transformers where low side phase-to-ground faults do not generate high side zero sequence currents (e.g. vector group Dy).

Since transformers transform symmetrical currents according to the transformation ratio "CTR", the relationship between negative sequence currents and total fault current for phase-to-phase faults and phase-to-ground faults are valid for the transformer as long as the turns ratio "CTR" is taken into consideration.

Consider a transformer with the following data:

Base Transformer Rating	$S_{NomT} = 16 \text{ MVA}$	
Primary Nominal Voltage	$V_{Nom} = 110 \text{ kV}$	
Secondary Nominal Voltage	$V_{Nom} = 20 \text{ kV}$	($TR_V = 110/20$)
Vector Groups	Dy5	
High Side CT	100 A / 1 A	($CT_I = 100$)

The following fault currents may be detected at the low side:

If **46-1 PICKUP** on the high side of the devices is set to = 0.1, then a fault current of $I = 3 \cdot TR_V \cdot TR_I \cdot \mathbf{46-1 PICKUP} = 3 \cdot 110/20 \cdot 100 \cdot 0.1 \text{ A} = 165 \text{ A}$ for single-phase faults and $\sqrt{3} \cdot TR_V \cdot TR_I \cdot \mathbf{46-1 PICKUP} = 95 \text{ A}$ can be detected for two-phase faults at the low side. This corresponds to 36% and 20% of the transformer nominal current respectively. It is important to note that load current is not taken into account in this simplified example.

As it cannot be recognized reliably on which side the thus detected fault is located, the delay time **46-1 DELAY** must be coordinated with other downstream relays in the system.

Pickup Stabilization (definite-time overcurrent protection)

Pickup of the definite time elements can be stabilized by means of a configurable dropout time. This dropout time is set in 4012 **46 T DROP-OUT**.

Inverse Time Tripping Curve

Several IEC and ANSI curves are available if your operational equipment requires the use of a curve-dependent tripping characteristic. They are selected at address 4006 **46 IEC CURVE** or at address 4007 **46 ANSI CURVE**

It must be noted that a safety factor of about 1.1 has already been included between the pickup value and the setting value when an inverse time Curve is selected. This means that a pickup will only occur if an unbalanced load of about 1.1 times the setting value **46-TOC PICKUP** is present (address 4008). Dropout occurs as soon as the value falls below 95 % of the pickup value. When selecting the ANSI curve in address 4011 **46-TOC RESET** the *Disk Emulation*, dropout will be performed according to the dropout curve as explained in the function description.

The associated time multiplier is specified at address 4010 **46-TOC TIMEDIAL** or address 4009**46-TOC TIMEDIAL**.

The time multiplier can also be set to ∞ . After pickup the Element will then not trip. Pickup, however, will be signaled. If the inverse time Element is not required at all, address 140 **46** should be set to **Definite Time** during the configuration of protection functions (Section 2.1.1.2).

2.7.4 Settings

Addresses which have an appended "A" can only be changed with DIGSI, under "Display Additional Settings".

The table indicates region-specific default settings. Column C (configuration) indicates the corresponding secondary nominal current of the current transformer.

Addr.	Parameter	C	Setting Options	Default Setting	Comments
4001	FCT 46		OFF ON	OFF	46 Negative Sequence Protection
4002	46-1 PICKUP	1A	0.05 .. 3.00 A	0.10 A	46-1 Pickup
		5A	0.25 .. 15.00 A	0.50 A	
4003	46-1 DELAY		0.00 .. 60.00 sec; ∞	1.50 sec	46-1 Time Delay
4004	46-2 PICKUP	1A	0.05 .. 3.00 A	0.50 A	46-2 Pickup
		5A	0.25 .. 15.00 A	2.50 A	
4005	46-2 DELAY		0.00 .. 60.00 sec; ∞	1.50 sec	46-2 Time Delay
4006	46 IEC CURVE		Normal Inverse Very Inverse Extremely Inv.	Extremely Inv.	IEC Curve
4007	46 ANSI CURVE		Extremely Inv. Inverse Moderately Inv. Very Inverse	Extremely Inv.	ANSI Curve
4008	46-TOC PICKUP	1A	0.05 .. 2.00 A	0.90 A	46-TOC Pickup
		5A	0.25 .. 10.00 A	4.50 A	
4009	46-TOC TIMEDIAL		0.50 .. 15.00 ; ∞	5.00	46-TOC Time Dial
4010	46-TOC TIMEDIAL		0.05 .. 3.20 sec; ∞	0.50 sec	46-TOC Time Dial
4011	46-TOC RESET		Instantaneous Disk Emulation	Instantaneous	46-TOC Drop Out
4012A	46 T DROP-OUT		0.00 .. 60.00 sec	0.00 sec	46 Drop-Out Time Delay

2.7.5 Information List

No.	Information	Type of Information	Comments
5143	>BLOCK 46	SP	>BLOCK 46
5151	46 OFF	OUT	46 switched OFF
5152	46 BLOCKED	OUT	46 is BLOCKED
5153	46 ACTIVE	OUT	46 is ACTIVE
5159	46-2 picked up	OUT	46-2 picked up
5165	46-1 picked up	OUT	46-1 picked up
5166	46-TOC pickedup	OUT	46-TOC picked up
5170	46 TRIP	OUT	46 TRIP
5171	46 Dsk pickedup	OUT	46 Disk emulation picked up

2.8 Frequency Protection 81 O/U

The frequency protection function detects abnormally high and low frequencies in the system or in electrical machines. If the frequency lies outside the allowable range, appropriate actions are initiated, such as load shedding or separating a generator from the system.

Applications

- Decrease in system frequency occurs when the system experiences an increase in the real power demand, or when a malfunction occurs with a generator governor or automatic generation control (AGC) system. The frequency protection function is also used for generators which (for a certain time) operate to an island network. This is due to the fact that the reverse power protection cannot operate in case of a drive power failure. The generator can be disconnected from the power system by means of the frequency decrease protection.
- Increase in system frequency occurs e.g. when large blocks of load (island network) are removed from the system, or again when a malfunction occurs with a generator governor. This entails risk of self-excitation for generators feeding long lines under no-load conditions.

From V04.73 on special voltage and frequency protection functions according to the standard CEI 0-16 were added.

If chosen, the standard / global voltage and frequency protection functions are replaced by the CEI 0-16 specific ones. The selection is done via MLFB position 14: if *F* is chosen, the global functions are active, if *G* is chosen, the CEI 0-16 functions are active.

In the following chapters both frequency protection standards will be described separately.

2.8.1 Frequency Protection 81 O/U (Global Standard)

2.8.1.1 Description

Frequency Detection

The frequency is detected preferably from the positive sequence voltage. If this voltage is too low, the phase-to-phase voltage V_{A-B} at the device is used. If the amplitude of this voltage is too small, one of the other phase-to-phase voltages is used instead.

Through the use of filters and repeated measurements, the frequency evaluation is free from harmonic influences and very accurate.

Overfrequency/Underfrequency

Frequency protection consists of four frequency elements. To make protection flexible for different power system conditions, these elements can be used alternatively for frequency decrease or increase separately, and can be independently set to perform different control functions.

Operating Range

The frequency can be determined as long as in a three-phase voltage transformer connection the positive-sequence system of the voltages, or alternatively, in a single-phase voltage transformer connection, the respective voltage is present and of sufficient magnitude. If the measured voltage drops below a settable value **V_{min}**, the frequency protection is blocked because no precise frequency values can be calculated from the signal.

Time Delays / Logic

Each frequency element has an associated settable time delay. When the time delay elapses, a trip signal is generated. When a frequency element drops out, the tripping command is immediately terminated, but not before the minimum command duration has elapsed.

Each of the four frequency elements can be blocked individually via binary inputs.

The following figure shows the logic diagram for the frequency protection function.

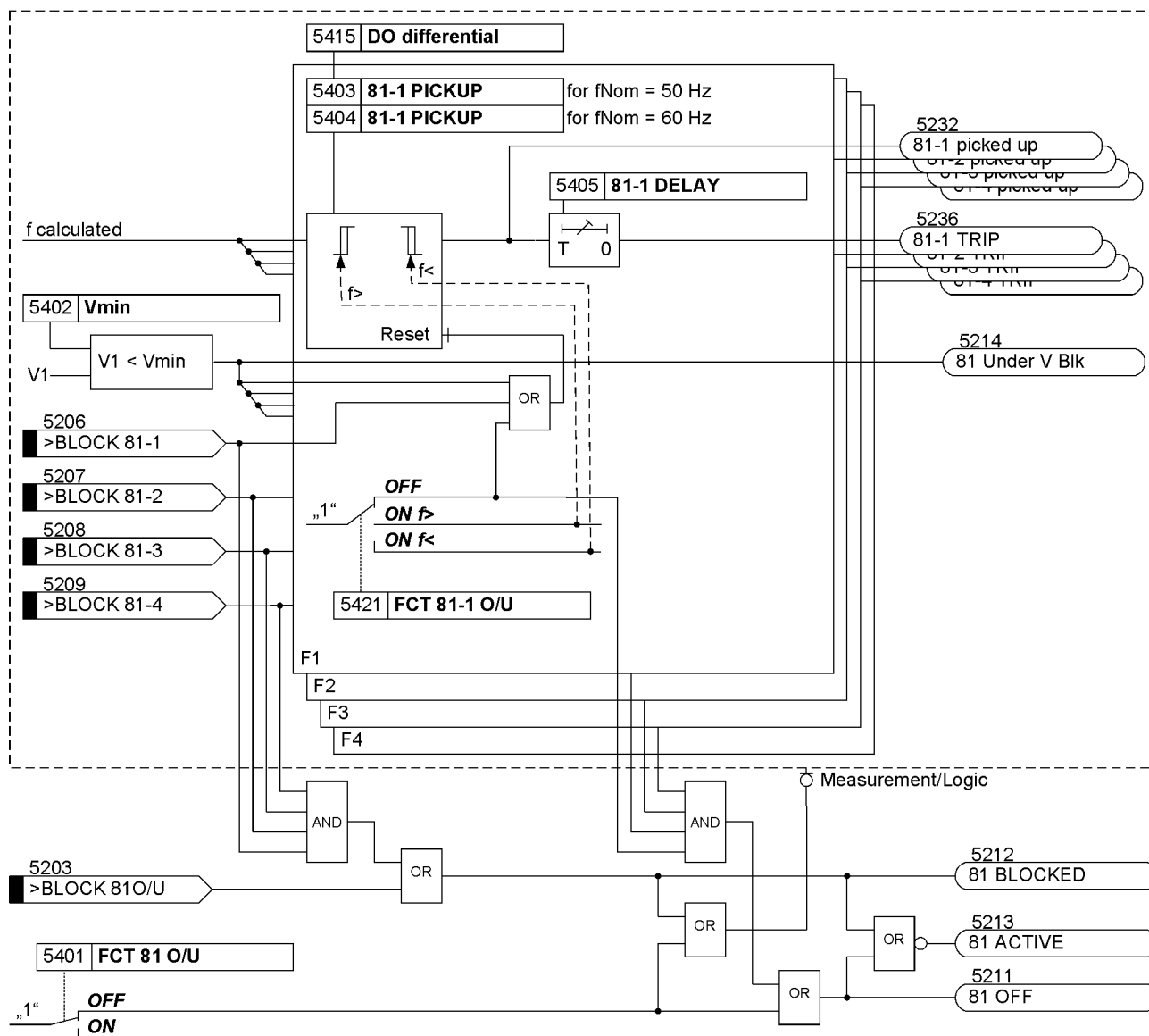

Figure 2-62 Logic diagram of the frequency protection

2.8.1.2 Setting Notes

General

Frequency protection is only in effect and accessible if address 154 **81 0/U** is set to **Enabled** during configuration of protective functions. If the function is not required **Disabled** is set. The function can be turned **ON** or **OFF** under address 5401 **FCT 81 0/U**.

By setting the parameters 5421 to 5424, the function of each of the elements **81-1 PICKUP** to **81-4 PICKUP** is set individually as overfrequency or underfrequency protection or set to **OFF**, if the element is not required.

Minimum Voltage

The minimum voltage below which the frequency protection is blocked is entered in address 5402 **Vmin**.

The threshold value has to be set as phase-to-phase quantity if the connection is three-phase. With a single-phase phase-to-Ground connection the threshold is set as phase voltage.

Pickup Values

The setting as overfrequency or underfrequency element does not depend on the parameter threshold values of the respective element. An element can also function, for example, as an overfrequency element if its threshold value is set below the nominal frequency and vice versa.

If frequency protection is used for load shedding purposes, the setting values depend on the actual power system conditions. Normally, a time coordinated load shedding is required that takes into account the importance of the consumers or consumer groups.

Further application examples exist in the field of power stations. Here too, the frequency values to be set mainly depend on the specifications of the power system / power station operator. The underfrequency protection safeguards the power station's own demand by disconnecting it from the power system on time. The turbo governor regulates the machine set to the nominal speed. Consequently, the station's own demands can be continuously supplied at nominal frequency.

Under the assumption that the apparent power is reduced by the same degree, turbine-driven generators can, as a rule, be continuously operated down to 95% of the nominal frequency. However, for inductive consumers, the frequency reduction not only means an increased current input, but also endangers stable operation. For this reason, only a short-term frequency reduction down to about 48 Hz (for $f_N = 50$ Hz) or 58 Hz (for $f_N = 60$ Hz) is permissible.

A frequency increase can, for example, occur due to a load shedding or malfunction of the speed regulation (e.g. in an island network). In this way, the frequency increase protection can, for example, be used as over-speed protection.

Dropout Thresholds

The dropout threshold is defined via the adjustable dropout-difference address 5415 **D0 differential**. It can thus be adjusted to the network conditions. The dropout difference is the absolute-value difference between pickup threshold and dropout threshold. The default value of 0.02 Hz can usually remain. Should, however, frequent minor frequency fluctuations be expected, this value should be increased.

Time Delays

The delay times **81-1 DELAY** to **81-4 DELAY** (addresses 5405, 5408, 5411 and 5414) allow the frequency elements to be time coordinated, e.g. for load shedding equipment. The set times are additional delay times not including the operating times (measuring time, dropout time) of the protection function.

2.8.1.3 Settings

Addresses which have an appended "A" can only be changed with DIGSI, under "Display Additional Settings".

Addr.	Parameter	Setting Options	Default Setting	Comments
5401	FCT 81 O/U	OFF ON	OFF	81 Over/Under Frequency Protection
5402	Vmin	10 .. 150 V	65 V	Minimum required voltage for operation

Addr.	Parameter	Setting Options	Default Setting	Comments
5402	Vmin	20 .. 150 V	35 V	Minimum required voltage for operation
5403	81-1 PICKUP	40.00 .. 60.00 Hz	49.50 Hz	81-1 Pickup
5404	81-1 PICKUP	50.00 .. 70.00 Hz	59.50 Hz	81-1 Pickup
5405	81-1 DELAY	0.00 .. 100.00 sec; ∞	60.00 sec	81-1 Time Delay
5406	81-2 PICKUP	40.00 .. 60.00 Hz	49.00 Hz	81-2 Pickup
5407	81-2 PICKUP	50.00 .. 70.00 Hz	59.00 Hz	81-2 Pickup
5408	81-2 DELAY	0.00 .. 100.00 sec; ∞	30.00 sec	81-2 Time Delay
5409	81-3 PICKUP	40.00 .. 60.00 Hz	47.50 Hz	81-3 Pickup
5410	81-3 PICKUP	50.00 .. 70.00 Hz	57.50 Hz	81-3 Pickup
5411	81-3 DELAY	0.00 .. 100.00 sec; ∞	3.00 sec	81-3 Time delay
5412	81-4 PICKUP	40.00 .. 60.00 Hz	51.00 Hz	81-4 Pickup
5413	81-4 PICKUP	50.00 .. 70.00 Hz	61.00 Hz	81-4 Pickup
5414	81-4 DELAY	0.00 .. 100.00 sec; ∞	30.00 sec	81-4 Time delay
5415A	DO differential	0.02 .. 1.00 Hz	0.02 Hz	Dropout differential
5421	FCT 81-1 O/U	OFF ON f> ON f<	OFF	81-1 Over/Under Frequency Protection
5422	FCT 81-2 O/U	OFF ON f> ON f<	OFF	81-2 Over/Under Frequency Protection
5423	FCT 81-3 O/U	OFF ON f> ON f<	OFF	81-3 Over/Under Frequency Protection
5424	FCT 81-4 O/U	OFF ON f> ON f<	OFF	81-4 Over/Under Frequency Protection

2.8.1.4 Information List

No.	Information	Type of Information	Comments
5203	>BLOCK 81O/U	SP	>BLOCK 81O/U
5206	>BLOCK 81-1	SP	>BLOCK 81-1
5207	>BLOCK 81-2	SP	>BLOCK 81-2
5208	>BLOCK 81-3	SP	>BLOCK 81-3
5209	>BLOCK 81-4	SP	>BLOCK 81-4
5211	81 OFF	OUT	81 OFF
5212	81 BLOCKED	OUT	81 BLOCKED
5213	81 ACTIVE	OUT	81 ACTIVE
5214	81 Under V Blk	OUT	81 Under Voltage Block
5232	81-1 picked up	OUT	81-1 picked up
5233	81-2 picked up	OUT	81-2 picked up
5234	81-3 picked up	OUT	81-3 picked up

No.	Information	Type of Information	Comments
5235	81-4 picked up	OUT	81-4 picked up
5236	81-1 TRIP	OUT	81-1 TRIP
5237	81-2 TRIP	OUT	81-2 TRIP
5238	81-3 TRIP	OUT	81-3 TRIP
5239	81-4 TRIP	OUT	81-4 TRIP

2.8.2 Frequency Protection 81 O/U (CEI 0-16 Standard)

CEI 0-16 PI protection function aim is always to disconnect the plant in case of fault in the MV network.

This frequency protection fulfills CEI 0-16 Standard, it is different from Global Standard, CEI 0-16 Standard and Global Standard are used alternatively.

CEI 0-16 Standard frequency protection has the following additional features:

- Voltmetric unblock feature 81V, it evaluates the symmetric components V1, V2, V0
- 59V0 trip element
- Measure frequency on three phases
- Accelerated feature

2.8.2.1 Description

Frequency Detection

The frequency is detected from each ph-ph voltage on three phases.

Through the use of filters and repeated measurements, the frequency evaluation is free from harmonic influences and very accurate.

Overfrequency/Underfrequency

Frequency protection consists of four frequency elements. 81>.S1 and 81>.S2 are overfrequency elements, 81<.S1 and 81<.S2 are underfrequency elements.

81>.S1 and 81<.S1 are restrictive with voltmetric unblock feature 81V, it means if 81V is not satisfied, 81>.S1 and 81<.S1 will not pickup even if frequency lies outside the allowable range.

As several measured frequencies are used, the trip is provided:

- In case of under frequency, evaluating the lowest measured value of frequency.
- In case of over frequency, evaluating the higher measured value of frequency.

Operating Range

The frequency can be determined as long as the respective voltages are present and of sufficient magnitude. If the measured voltage drops below a settable value **Vmin**, the corresponding frequency calculated from this voltage will not be evaluated in frequency protection because no precise frequency value can be calculated from this signal; If all the measured voltages drop below **Vmin**, the frequency protection is blocked. **Vmin** is set to 0.2 Un as indicated in the CEI 0-16 standard.

Voltmetric Unblock Feature 81V

The voltmetric unblock feature is based on the following elements:

- Zero sequence overvoltage (59V0);
- Negative sequence overvoltage (81V 59V2);
- Positive sequence undervoltage (81V 27V1).

Each voltage element has a settable threshold value and settable dropout ratio.

“**Loc 81V En**” is a local command, it can be switch **ON/OFF** by communication control command or control menu for different operation mode:

- If the local command is in **OFF** state, 81>.S1 and 81<.S1 are blocked, except in the case of intervention of the voltmetric unblock feature 81V;.
- If the local command is in **ON** state, 81>.S1 and 81<.S1 are released, regardless of the intervention of the voltmetric unblock feature 81V.

Reset time (**81V Rst T1 59V0** and **81V Rst T2 81V**) is used in case of intermittent arc, or when a fault is cleared, to avoid repetitive pick-ups and drop-offs of 59V0.

Zero Sequence Overvoltage 59V0 Element

59V0 is not only a voltmetric unblock feature 81V for 81 S1, but also an independent function, it can be blocked by “>**DDI Open**”.

As an element of 81V, 59V0 always works regardless if the parameter 5421 **59V0** is **ON** or **OFF**.

The following figure shows the logic diagram for voltmetric unblock feature **81V** and **59V0**.

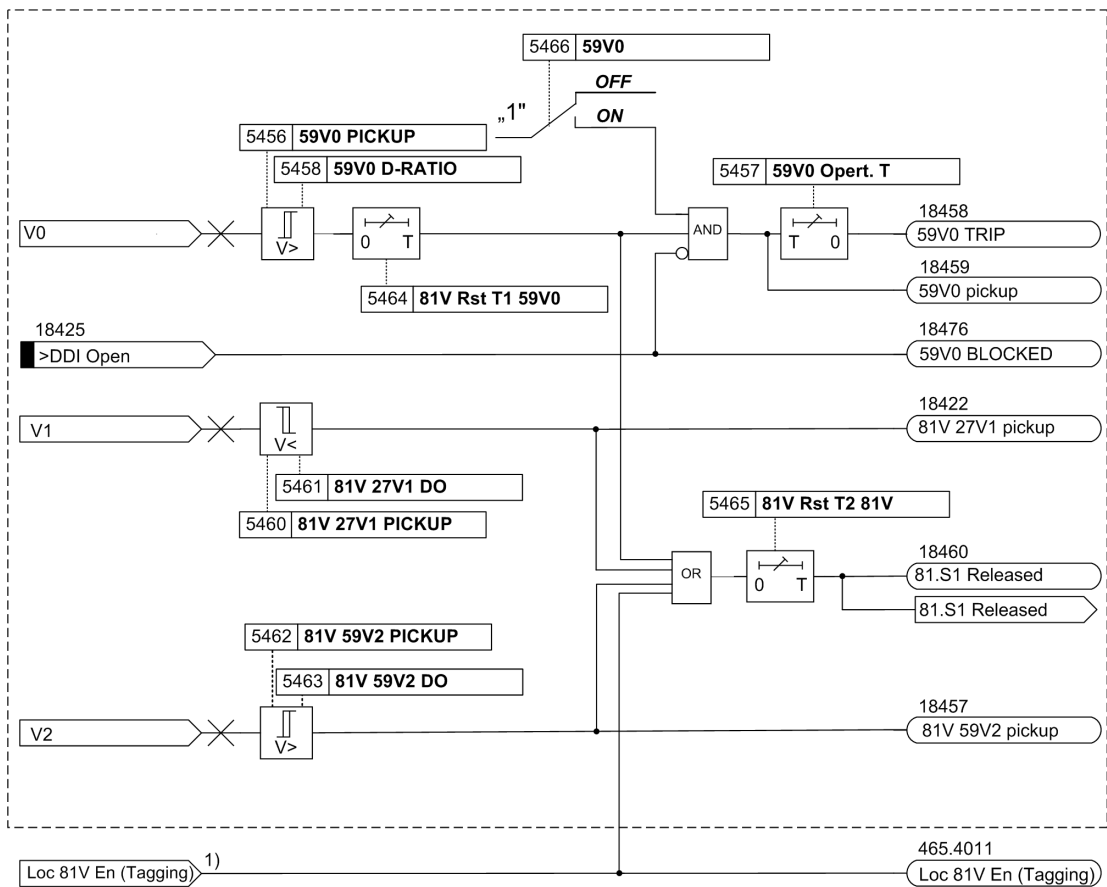

1) Tagging means control of this function by DIGSI- or station-command.

Figure 2-63 Logic diagram of the Voltmetric unblock feature 81V and 59V0

Time Delays / Logic

Each frequency element and zero sequence overvoltage **59V0** element have an associated settable time delay. When the time delay elapses, a trip signal is generated. When a frequency element drops out, the tripping command is immediately terminated, but not before the minimum command duration has elapsed.

Accelerated Feature

With the ">**Manual Close**" command the tripping times of 81>.S2, 81<.S2, 59V0 are reduced to the value given in **Acce1. Oper. T** (while maintaining unchanged the time delays of the remaining functions) for a certain time after the closure of the DDI.

The duration of this accelerated status is settable (5737 **Acce1. Act. T**, 30.00s as default setting), 30.00s is necessary because it should be possible to wait for a reclose cycle in the network.

The accelerating feature based on the removal of the ">DDI Open" signal should be activated only for static and for asynchronous non self- excited generators. For this purpose the parameter 616 must be set to **YES**.

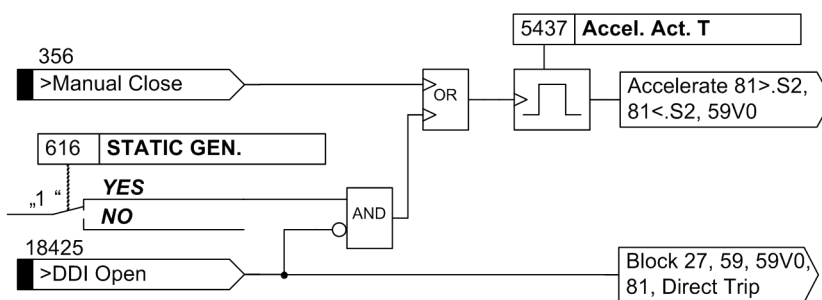

Figure 2-64 Logic diagram of accelerating feature

Each of the four frequency elements can be blocked individually via binary inputs and “>DDI Open”.

The following figure shows the logic diagram for the frequency protection function.

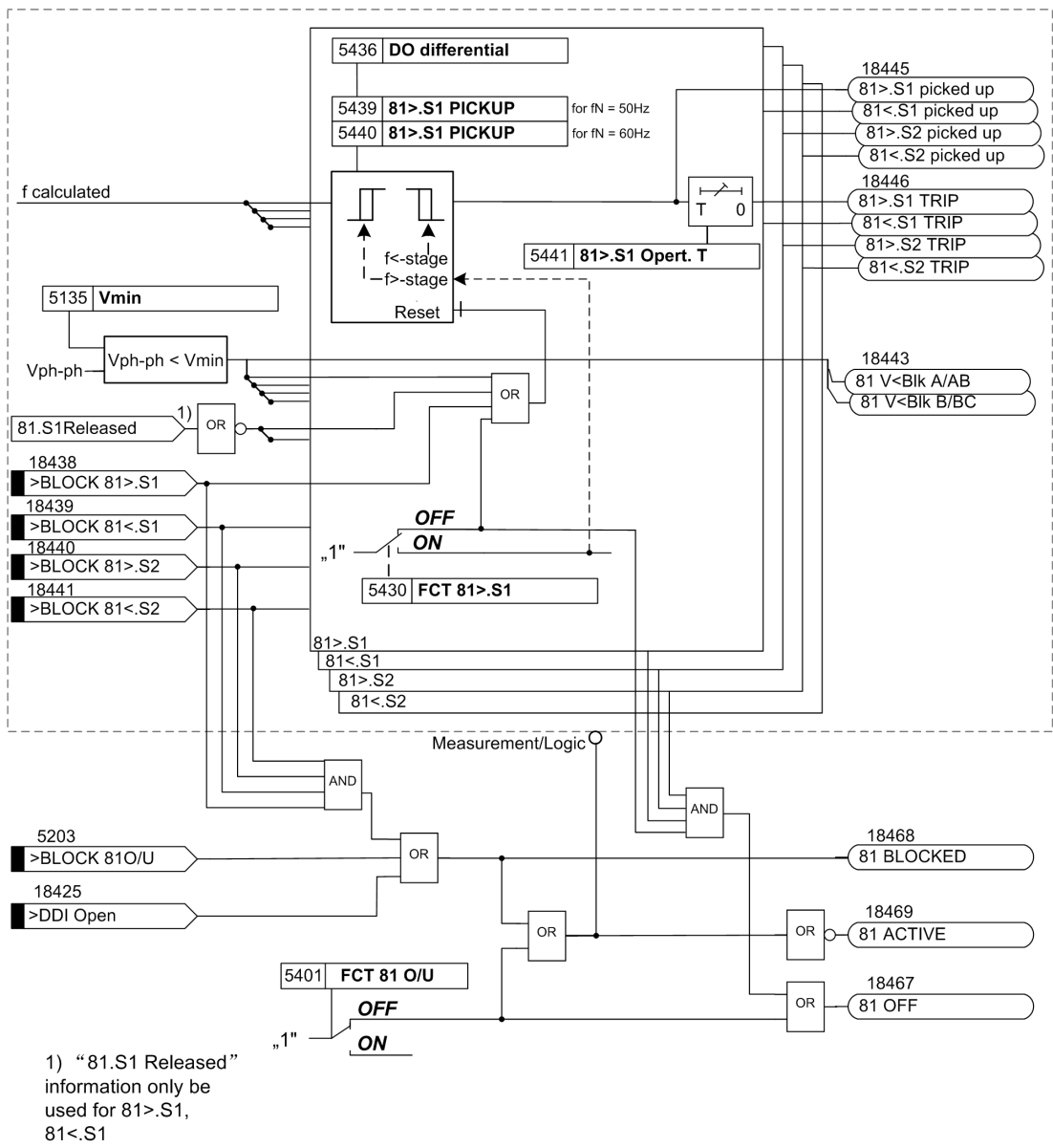

Figure 2-65 Logic diagram of the frequency protection

2.8.2.2 Setting Notes

General

Frequency protection and zero sequence overvoltage 59V0 elements are only active and accessible if address 154 **81 0/U** is set to **Enabled** during configuration of protective functions. If the function is not required **Disabled** is to be set.

The frequency function can be turned **ON** or **OFF** under address 5401 **FCT 81 0/U**.

By setting the parameters 5430 to 5433, the function of each of the frequency elements (**FCT 81>.S1**, **FCT 81<.S1**, **FCT 81>.S2**, **FCT 81<.S2**) is set to **OFF** if the element is not required.

Zero sequence overvoltage 59V0 element can be turned **ON** or **OFF** under address 5466 **59V0**.

All default settings are as described in the CEI 0-16 standard.

Minimum Voltage

The minimum voltage below which the frequency protection is blocked is entered in address 5435 **Vmin**.

The threshold value has to be set as phase-to-phase quantity.

Accelerated Time

During **Acce1. Act. T** (address 5437), 81>.S2, 81<.S2, 59V0 will be accelerated. If **Acce1. Act. T** is set to 0.00s, accelerated feature will not be active, 81>.S2, 81<.S2, 59V0 maintain the original time delays.

Voltage Threshold

81V 27V1 PICKUP (address 5460) evaluates positive sequence voltage, **81V 59V2 PICKUP** (address 5462) evaluates negative sequence voltage, they are set referred to the rated phase to earth voltage **U_{phn}**.

$$V_{phn} = \frac{V_n}{\sqrt{3}}$$

V_n Secondary nominal voltage (parameter 203 **Vnom SECONDARY**)

59V0 PICKUP (address 5456) evaluates zero sequence voltage, it is set referred to the rated displacement voltage **V_{en}**.

$$V_{en} = V_{phn} \times V_{ph} / V_{delta}$$

V_{ph}/V_{delta} Factor between the phase voltage and the displacement voltage (Parameter 206 **Vph / Vdelta**)

The dropout thresholds of the 81V 27V1 Element can be configured via the dropout ratio $r = V_{Dropout}/V_{Pickup}$ at address 5461 **81V 27V1 DO**. The following marginal condition applies to r:

$$r \cdot (\text{configured pickup threshold}) \leq 130 \text{ V}$$

The minimum hysteresis is 1.0 V.

The dropout thresholds of the 81V 59V2 Element can be configured via the dropout ratio $r = V_{Dropout}/V_{Pickup}$ at addresses 5463 **81V 59V2 DO**. The following marginal condition applies to r:

$$r \cdot (\text{configured pickup threshold}) \leq 150 \text{ V}$$

The minimum hysteresis is 1.0 V.

The dropout thresholds of the 59V0 element can be configured via the dropout ratio $r = V_{Dropout}/V_{Pickup}$ at addresses 5458 **59V0 D-RATIO**. The following marginal condition applies to r:

$$r \cdot (\text{configured pickup threshold}) \leq 200 \text{ V}$$

The minimum hysteresis is 1.0 V.

Frequency Pickup Values

Application of frequency protection (CEI 0-16) is to decouple a producer when a fault in the distribution network occurs.

Settings are usually indicated by the distribution network operator.

Frequency Dropout Thresholds

The dropout threshold is defined via the adjustable dropout-difference address 5436 **DO differential**. It can thus be adjusted to the network conditions. The dropout difference is the absolute-value difference between pickup threshold and dropout threshold. The default value of 0.10 Hz can usually remain. Should, however, frequent minor frequency fluctuations be expected, this value should be increased.

Time Delays

The delay times **81>.S1 Oper. T**, **81<.S1 Oper. T**, **81>.S2 Oper. T**, **81<.S2 Oper. T** (addresses 5441, 5445, 5449 and 5453) and **59V0 Oper. T** (address 5457) are different from other time delays, they cover the pickup time, function delay time and trip contact closing time.

2.8.2.3 Settings

Addresses which have an appended "A" can only be changed with DIGSI, under "Display Additional Settings".

Addr.	Parameter	Setting Options	Default Setting	Comments
5401	FCT 81 O/U	OFF ON	ON	81 Over/Under Frequency Protection
5430	FCT 81>.S1	OFF ON	ON	81 S1 Over Frequency Protection
5431	FCT 81<.S1	OFF ON	ON	81 S1 Under Frequency Protection
5432	FCT 81>.S2	OFF ON	ON	81 S2 Over Frequency Protection
5433	FCT 81<.S2	OFF ON	ON	81 S2 Under Frequency Protection
5466	59V0	OFF ON	ON	59V0 Zero sequence overvoltage
5435A	Vmin	0.20 .. 1.50 Un	0.20 Un	Minimum required volatge for operation
5436A	DO differential	0.02 .. 1.00 Hz	0.10 Hz	Dropout Differential
5437A	Accel. Act. T	0.00 .. 60.00sec	30.00 sec	Active Time of Accelerating Function
5438A	Accel. Oper. T	0.05 .. 5.00 sec	0.20 sec	Accelerated Operating Time
5439	81>.S1 PICKUP	50.00 .. 60.00 Hz	50.20 Hz	81>. S1 Pickup
5440	81>.S1 PICKUP	60.00 .. 70.00 Hz	60.20 Hz	81>. S1 Pickup
5441	81>.S1 Oper. T	0.05 .. 100.00 sec; ∞	0.15 sec	81>. S1 Operating Time
5443	81<.S1 PICKUP	40.00 .. 50.00 Hz	49.80 Hz	81<. S1 Pickup
5444	81<.S1 PICKUP	50.00 .. 60.00 Hz	59.80 Hz	81<. S1 Pickup
5445	81<.S1 Oper. T	0.05 .. 100.00 sec; ∞	0.15 sec	81<. S1 Operating Time
5447	81>.S2 PICKUP	50.00.. 60.00 Hz	51.50 Hz	81>. S2 Pickup
5448	81>.S2 PICKUP	60.00 .. 70.00 Hz	61.50 Hz	81>. S2 Pickup
5449	81>.S2 Oper. T	0.05 .. 100.00 sec;∞	1.00 sec	81>. S2 Operating Time
5451	81<.S2 PICKUP	40.00 .. 50.00 Hz	47.50 Hz	81<. S2 Pickup
5452	81<.S2 PICKUP	50.00 .. 60.00 Hz	57.50 Hz	81<. S2 Pickup

Addr.	Parameter	Setting Options	Default Setting	Comments
5453	81<.S2 Oper. T	0.05 .. 100.00 sec;∞	4.00 sec	81<. S2 Operating Time
5456	59V0 PICKUP	0.01 .. 1.15 Uen	0.05 Uen	59V0 Pickup
5457	59V0 Oper. T	0.05 .. 100.00 sec;∞	25.00 sec	59V0 Operating time
5458A	59V0 D-RATIO	0.90 .. 0.99	0.96	59V0 Dropout Ratio
5460	81V 27V1 PICKUP	0.10 .. 1.20 Uphn	0.70 Uphn	81V 27V1 Pickup
5461A	81V 27V1 DO	1.01 .. 3.00	1.04	81V 27V1 Dropout Ratio
5462	81V 59V2 PICKUP	0.02 .. 1.50 Uphn	0.15 Uphn	81V 59V2 Pickup
5463A	81V 59V2 DO	0.90 .. 0.99	0.96	81V 59V2 Dropout Ratio
5464A	81V Rst T1 59V0	0.00 .. 0.20 sec	0.20 sec	81V Reset Time 1 for 59V0
5465A	81V Rst T2 81V	1.00 .. 240.00 sec	30.00 sec	81V Reset Time 2 for volt release

2.8.2.4 Information List

No.	Information	Type of Information	Comments
5203	>BLOCK 81O/U	SP	>BLOCK 81O/U
18438	>BLOCK 81>.S1	SP	>BLOCK 81>.S1
18439	>BLOCK 81<.S1	SP	>BLOCK 81<.S1
18440	>BLOCK 81>.S2	SP	>BLOCK 81>.S2
18441	>BLOCK 81<.S2	SP	>BLOCK 81<.S2
18467	81 OFF	OUT	81 Frequency protection switched OFF
18468	81 BLOCKED	OUT	81 Frequency protection is BLOCKED
18469	81 ACTIVE	OUT	81 Frequency protection is ACTIVE
18442	81 V< Blk A/AB	OUT	81 Under Voltage Block Phase A/AB
18443	81 V< Blk B/BC	OUT	81 Under Voltage Block Phase B/BC
18445	81>.S1 pickup	OUT	81>.S1 picked up
18446	81>.S1 TRIP	OUT	81>.S1 TRIP
18448	81<.S1 pickup	OUT	81<.S1 picked up
18449	81<.S1 TRIP	OUT	81<.S1 TRIP
18451	81>.S2 pickup	OUT	81>.S2 picked up
18452	81>.S2 TRIP	OUT	81>.S2 TRIP
18454	81<.S2 pickup	OUT	81<.S2 picked up
18455	81<.S2 TRIP	OUT	81<.S2 TRIP
18459	59V0 pickup	OUT	59V0 picked up
18458	59V0 TRIP	OUT	59V0 TRIP
18476	59V0 BLOCKED	OUT	59V0 BLOCKED
18422	81V 27V1 pickup	OUT	81V 27V1 picked up
18457	81V 59V2 pickup	OUT	81V 59V2 picked up
18460	81.S1 Released	OUT	81.S1 Released
465.4011.01	Loc 81V En	IntSP	Local 81V Enable command

2.9 Undervoltage-controlled reactive power protection (27/Q)

The undervoltage-controlled reactive power protection protects the system for mains decoupling purposes. To prevent a voltage collapse in energy systems, the generating side, e.g. a generator, must be equipped with voltage and frequency protection devices. An undervoltage-controlled reactive power protection is required at the supply system connection point. It detects critical power system situations and ensures that the power generation facility is disconnected from the mains. Furthermore, it ensures that reconnection only takes place under stable power system conditions. The associated criteria can be parameterized.

Applications

- High-voltage and extra-high voltage power systems
- Medium-voltage power systems
- Regenerative infeed types such as wind power stations, photovoltaics, cogeneration plants or hydropower

2.9.1 Description

General

To detect critical power system situations, the QU protection uses the phase-to-phase voltage, the positive-sequence current and the reactive power.

To release the reconnection, the results of voltage protection and frequency protection are additionally analyzed on the generating side.

If the frequency and voltage values are outside the operating range, the QU protection does not work.

It can also be blocked by the fuse-failure monitor or via a binary input.

Pickup of the QU protection causes the device to pick up. Simultaneously, fault recording is activated. But tripping of the QU protection does **not** cause the device to trip and should be routed to a separate binary output. No other fault record is started.

The QU protection can be used for all voltage connection types that enable detection of the displacement voltage (measured or calculated). The Appendix provides connection examples.

Signal transmission in the high-voltage power system requires the power system connection point and the generating facility to be connected via telecommunication cables (optical fiber or copper cable). Radio links, GPRS or satellite transmission with signal transit times < 3 s can alternatively be used in medium-voltage systems.

Protection Function

The QU protection trips under the following conditions:

- All 3 phase-to-phase voltages are below the parameterized threshold value.
- The positive-sequence current I_1 is above the parameterized threshold value.
- The facility requires more than the set reactive power.

The pickup thresholds for undervoltage **U< Pickup**, the reactive power **Q> Pickup** and the release current **I-Release** can be set.

After detection of the tripping criteria, time-delayed trip signals are sent to the circuit breaker of the power system connection point and to the circuit breaker of the generating facility. The time delay can be set separately for both circuit breakers. Time-graded tripping is thus possible. The tripping of the circuit breaker at the power system connection point ultimately de-energizes the entire generating facility.

To prevent tripping of the QU protection during starting operations, parameterize and activate the inrush current detection. The inrush blocking of the QU protection can then be activated via parameter **Inrush blk**. The

overcurrent protection detects the inrush. The QU protection evaluates the inrush indications of the overcurrent protection (see Figure 2-19).

The following figure shows the logic diagram of the QU protection.

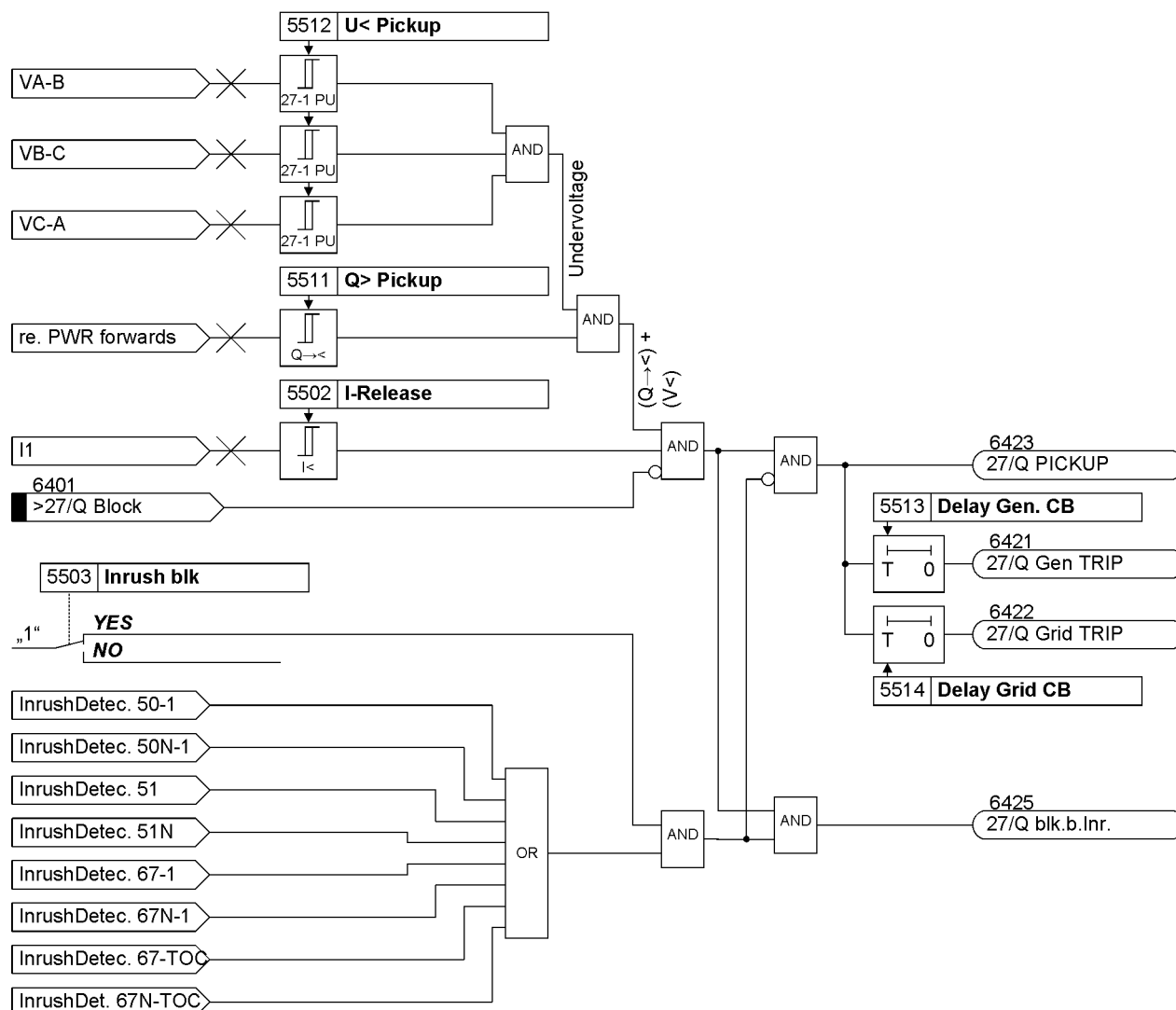

Figure 2-66 Logic diagram of the QU protection

Reconnection

The release for reconnecting the generating facility is given under the following conditions:

- All 3 phase-to-phase voltages are above the parameterized threshold value.
- The power system frequency is within the parameterized range.
- The delay time of the protection function has elapsed. The delay time is started by the first trip signal of any stage of the voltage or frequency protection.

The release criteria for reconnection can be set. The following parameters are used:

- Threshold for the release voltage at the power system connection point
- Frequency deviation in positive and negative direction
- Reconnection release can be delayed by a settable time.

You also define whether the tripping of the circuit breaker at the generating facility is included in the formation of the release signal. The tripping of the protection stages of voltage and frequency protection is always included.

The following figure shows the logic diagram of the QU protection for reconnection.

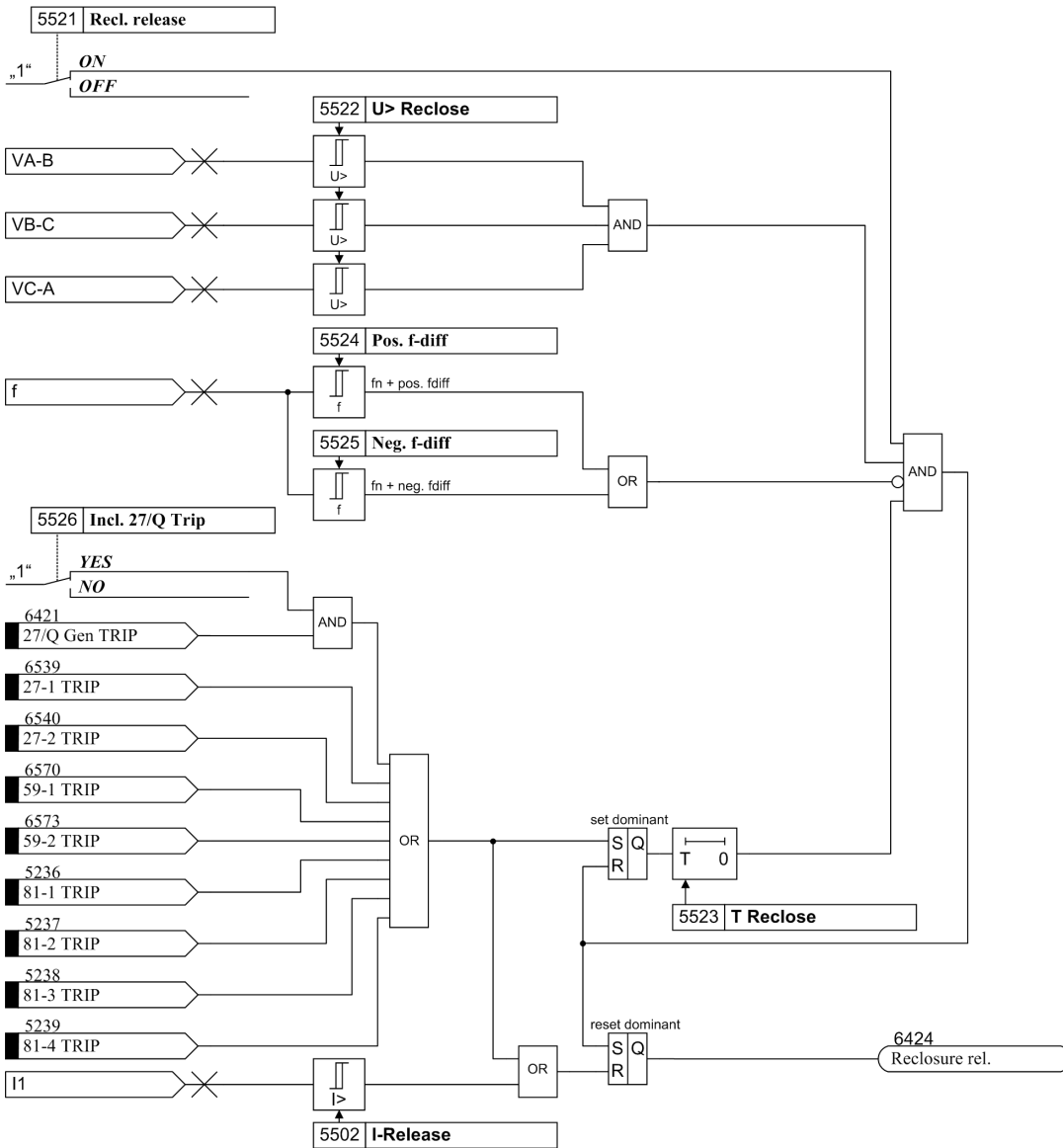

Figure 2-67 Logic diagram of QU protection restarting

2.9.2 Setting Notes

General

Configuration of the protection functions at address 155 **27/Q-Protection** defines whether the QU protection is **Enabled** or **Disabled**.

At address 5501 **27/Q-Protection** the QU protection function can be switched **ON** or **OFF**.

The release current is entered at address 5502 **I - Release**. The default setting is at 10 % of the rated current. The threshold is one of the pickup criteria for tripping.

At address 5503 **Inrush blk** you can activate the blocking when inrush has been detected.

Pickup Values

You can set the pickup value for the reactive power stage at address 5511 **Q> Pickup**.

Example:

$Q > 5\%$ of the supply system rating

$V_{Nsec} = 100\text{ V}$

$I_{Nsec} = 1\text{ A}$

this yields the (default) setting value **Q> Pickup** for **Q> Pickup**

$100\text{ V} \cdot 1\text{ A} \cdot \sqrt{3} \cdot 0.05 = 8.7\text{ VAR}$

At address 5512 **U< Pickup**, you can enter the pickup value for the voltage stage.

Delays

Address 5513 **Delay Gen. CB** is used to set the time delay for tripping the circuit breaker of the generation facility, e.g. at the generator.

Enter the time delay for tripping the circuit breaker at the supply system connection point at address 5514 **Delay Grid CB**. Always set the delay time longer than delay time **Delay Gen. CB**.

Close Release

At address 5521 **Recl. release** the close release is switched **ON** or **OFF**.

At address 5522 **U> Reclose** you can specify the release voltage. Set the value to approx. 95 % of the rated voltage value (default).

Specify the delay time for releasing the generator reconnection at address 5523 **T Reclose**.

Furthermore, enter the admitted deviation from the rated frequency. At address 5524 **Pos. f-diff** enter the frequency deviation in positive direction and at address 5525 **Neg. f-diff** in negative direction. If the measured frequency is within this range, this reconnection condition is satisfied.

Address 5526 **Incl. 27/Q Trip** determines whether the tripping indication of the QU protection is taken into account for the reconnection release.

2.9.3 Settings

Addresses which have an appended "A" can only be changed with DIGSI, under "Display Additional Settings".

The table indicates region-specific default settings. Column C (configuration) indicates the corresponding secondary nominal current of the current transformer.

Addr.	Parameter	C	Setting Options	Default Setting	Comments
5501	27/Q-Protection		OFF ON	OFF	27 / Q dir. con. Protection
5502	I-Release	1A	0.02 .. 0.20 A	0.10 A	Current-Rel. for Trip and Reclose
		5A	0.10 .. 1.00 A	0.50 A	
5503	Inrush blk		NO YES	NO	blocking with inrush
5511	Q> Pickup	1A	1.70 .. 10000.00 VAR	8.70 VAR	Reactive power threshold for pickup
		5A	8.50 .. 50000.00 VAR	43.50 VAR	
5512	U< Pickup		10.00 .. 210.00 V	85.00 V	Undervoltage threshold for pickup
5513	Delay Gen. CB		0.00 .. 60.00 sec	0.50 sec	Trip time delay generator CB
5514	Delay Grid CB		0.00 .. 60.00 sec	1.50 sec	Trip time delay grid CB
5521	Recl. release		OFF ON	OFF	Reclosure release
5522	U> Reclose		10.00 .. 210.00 V	95.00 V	Voltage threshold for reclosure rel.
5523	T Reclose		0.00 .. 3600.00 sec	0.00 sec	Reclosure Delay Time
5524	Pos. f-diff		0.01 .. 5.00 Hz	0.05 Hz	Pos. f-diff threshold for reclosure rel.
5525	Neg. f-diff		-5.00 .. -0.01 Hz	-2.50 Hz	Neg. f-diff threshold for reclosure rel.
5526A	Incl. 27/Q Trip		NO YES	NO	Include 27/Q Trip for reclosure rel.

2.9.4 Information List

No.	Information	Type of Information	Comments
6401	>27/Q Block	SP	>QV-Protection Blocked
6411	27/Q OFF	OUT	27/Q -Protection off
6412	27/Q block	OUT	27/Q -Protection blocked
6413	27/Q ACT	OUT	27/Q -Protection active
6421	27/Q Gen TRIP	OUT	27/Q -Protection Gen TRIP
6422	27/Q Grid TRIP	OUT	27/Q -Protection Grid TRIP
6423	27/Q PICKUP	OUT	27/Q-Protection PICKUP
6424	Reclosure rel.	OUT	Reclosure release
6425	27/Q blk.b.Inr.	OUT	27/Q pickup blocked by Inrush

2.10 Thermal Overload Protection 49

The thermal overload protection is designed to prevent thermal overloads from damaging the protected equipment. The protection function represents a thermal replica of the equipment to be protected (overload protection with memory capability). Both the previous history of an overload and the heat loss to the environment are taken into account.

Applications

- The thermal condition particularly of generators and transformers can be monitored in this way.

2.10.1 Description

Thermal Replica

The device calculates the overtemperature in accordance with a single-body thermal replica, based on the following differential equation:

$$\frac{d\Theta}{dt} + \frac{1}{\tau_{th}} \cdot \Theta = \frac{1}{\tau_{th}} \cdot \left(\frac{I}{k \cdot I_{Nom\ Obj.}} \right)^2$$

with

Θ	Present overtemperature related to the final overtemperature at maximum allowed phase current $k \cdot I_{Nom\ Obj.}$
τ_{th}	Thermal time constant of the protected object's heating
I	Present true r.m.s value of phase current
k	k-factor indicating the maximum permissible constant phase current referred to the nominal current of the protected object
$I_{Nom\ Obj.}$	Nominal current of protected object

The protection function provides a thermal replica of the protected object (overload protection with memory capability). The history of an overload is taken into consideration.

When the calculated overtemperature reaches the first settable threshold **49** Θ **ALARM**, an alarm annunciation is issued, e.g. to allow time for the load reduction measures to take place. When the calculated overtemperature reaches the second threshold, the protected equipment may be disconnected from the system. The highest overtemperature calculated from the three phase currents is used as the criterion.

The maximum thermally permissible continuous current I_{max} is described as a multiple of the object nominal current $I_{Nom\ Obj.}$:

$$I_{max} = k \cdot I_{Nom\ Obj.}$$

In addition to the k factor (parameter **49 K-FACTOR**), the **TIME CONSTANT** τ_{th} and the alarm temperature **49** Θ **ALARM** (in percent of the trip temperature Θ_{TRIP}) must be specified.

Since the 7SJ80 does not offer a connection option for an RTD box, the current temperature Θ is always equal to zero.

Overload protection also features a current warning element (**I ALARM**) in addition to the temperature warning element. The current warning element may report an overload current prematurely, even if the calculated operating temperature has not yet attained the warning or tripping levels.

Extension of the Time Constants

When using the device to protect motors, the varying thermal response associated with stationary or rotating machine can be evaluated correctly. When decelerating or stationary, a motor without external cooling loses heat more slowly, and a longer thermal time constant must be used for calculation. For a motor that is switched off, the 7SJ80 increases the time constant τ_{th} by a configurable extension factor ($k\tau$ factor). The motor is considered switched off when the motor currents drop below a configurable minimum current setting **BkrClosed I MIN** (refer to "Current Flow Monitoring" in Section 2.1.3). For externally-cooled machines, cables or transformers, the **K τ -FACTOR** is **1**.

Blocking

The thermal memory may be reset via a binary input („>RES 49 Image“) and the current-related overtemperature value is thus reset to zero. The same is accomplished via the binary input („>BLOCK 49 0/L“); in this case, the entire overload protection is blocked completely, including the current warning element.

When machines must be operated beyond the maximum permissible overtemperatures (emergency startup), the tripping signal alone can be blocked via a binary input („>EmergencyStart“). Since the thermal replica may have exceeded the tripping temperature after initiation and dropout of the binary input has taken place, the protection function features a programmable run-on time interval (**T EMERGENCY**) which is started when the binary input drops out and continues suppressing a trip signal. Tripping via the overload protection is suppressed until this time interval has elapsed. The binary input affects only the trip command. There is no effect on the trip log nor does the thermal replica reset.

Behavior in Case of Power Supply Failure

Depending on the setting in address 235 **100** of Power System Data 1 (see Section 2.1.3.2) the value of the thermal replica is either reset to zero (**ATEX100 = NO**) if the power supply voltage fails, or cyclically buffered in a non-volatile memory (**ATEX100 = YES**) so that it is maintained in the event of auxiliary supply voltage failure. In the latter case, when power supply is restored, the thermal replica uses the stored value for calculation and matches it to the operating conditions. The first option is the default setting. For further details, see /5/.

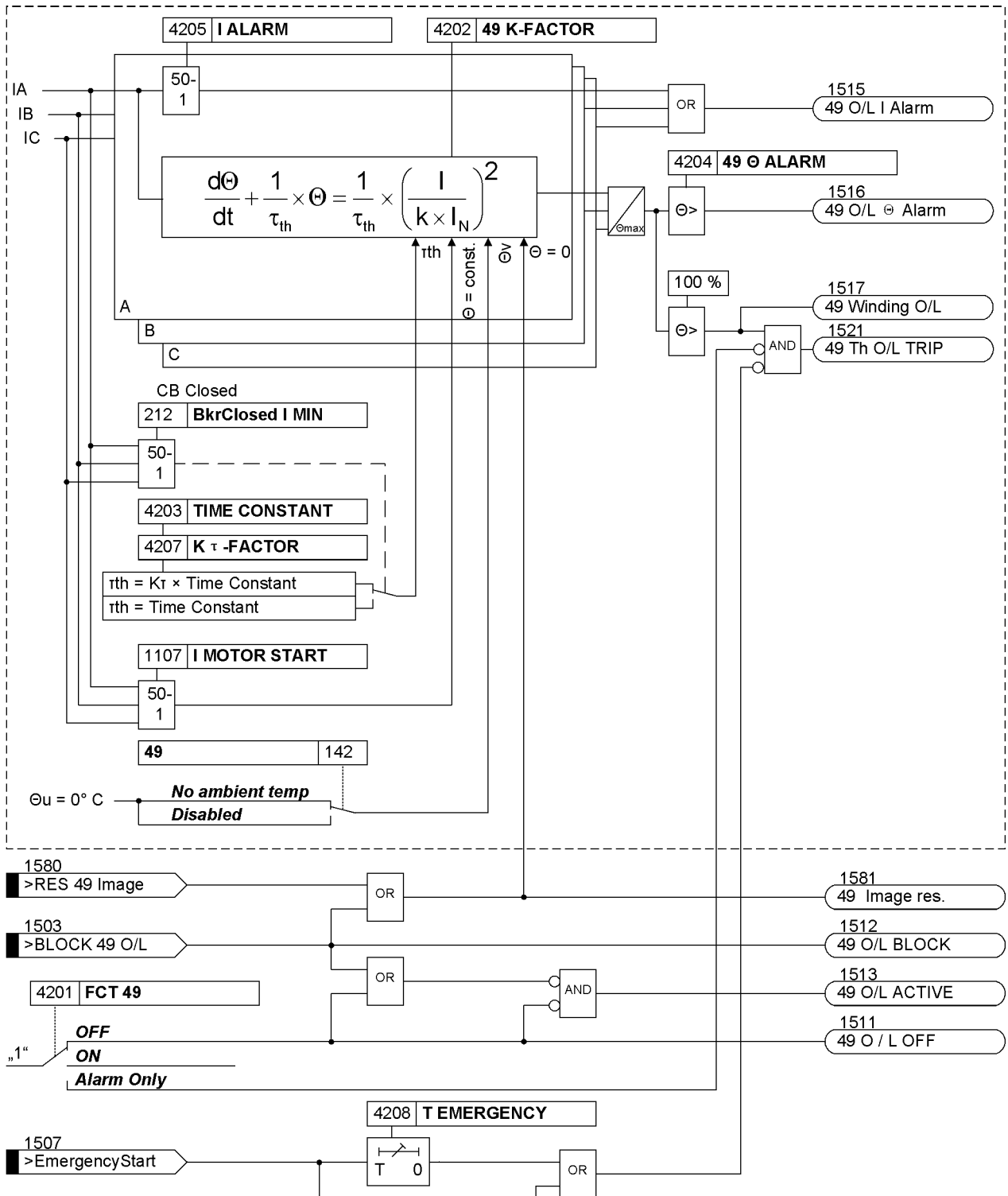

Figure 2-68 Logic diagram of the overload protection

2.10.2 Setting Notes

General

Overload protection is only in effect if address 142 **49** is set to **No ambient temp** during configuration. If this function is not required, select **Disabled**.

Transformers and cable are prone to damage by overloads that last for an extended period of time. Overloads cannot and should not be detected by fault protection. Time overcurrent protection should be set high enough to only detect faults since these must be cleared in a short time. Short time delays, however, do neither allow measures to discharge overloaded equipment nor do they permit to take advantage of its (limited) overload capacity.

The 7SJ80 devices feature an overload protection function with thermal tripping characteristic adaptable to the overload capability of the equipment being protected (overload protection with memory function).

Overload protection can be switched **ON** or **OFF** or set to **Alarm Only** at address 4201 **FCT 49**. If overload protection is **ON**, tripping, trip log and fault recording is possible.

When setting **Alarm Only** no trip command is given, no trip log is initiated and no spontaneous fault annunciation is shown on the display.

Since the 7SJ80 does not offer a connection option for an RTD box, the current temperature Θ is always equal to zero.

The overload protection is intended to protect lines and cables against thermal overload.



Note

Changing the function parameters resets the thermal replica. The thermal model is frozen (kept constant), as soon as the current exceeds the setting value 1107 **I MOTOR START**.

Overload Parameter k-factor

The overload protection is set in reference values. The nominal current $I_{\text{Nom Obj}}$ of the protected object (cable) is used as the basic current for overload detection. By means of thermal consistently permissible current I_{max} , factor k_{prim} can be calculated:

$$k_{\text{prim}} = \frac{I_{\text{max prim}}}{I_{\text{Nom Obj}}}$$

The thermally admissible continuous current for the equipment being protected is generally obtainable from manufacturers specifications. For cables, the permissible continuous current is dependent on the cross-section, insulating material, design, and the cable routing, among other things. It can be taken from pertinent tables, or is specified by the cable manufacturer. If no specifications are available, select 1.1 times the nominal current. There are usually no specifications for overhead lines but we can also assume an admissible overload of 10% here.

Example: Belted cable 10 kV, 150 mm²:

Permissible continuous current

$$I_{\text{max}} = 322 \text{ A}$$

Nominal current with k-factor 1.1

$$I_{\text{Nom Obj.}} = 293 \text{ A}$$

Time Constant τ

In lines and cables it is only the thermal time constant that is decisive for reaching the temperature rise limit.

For cable protection, the **TIME CONSTANT**, address 4203, is determined by the cable specifications and by the cable environment. If no specifications about the time constant are available, it can be determined from the short-term load capability of the cable. The 1-sec current, i.e. the maximum current permissible for a one-second period of time, is often known or available from tables. The time constant can then be calculated using the following formula:

$$\text{Set Value } \tau_{\text{th}} \text{ (min)} = \frac{1}{60} \cdot \left(\frac{I_{1\text{sec}}}{I_{\text{max prim}}} \right)^2$$

If the short-term load capability is given for an interval other than one second, the corresponding short-term current is used in the above formula instead of the 1-second current, and the result is multiplied by the given duration. For example, if the 0.5-second current rating is known:

$$\text{Set Value } \tau_{\text{th}} \text{ (min)} = \frac{0.5}{60} \cdot \left(\frac{I_{0.5 \text{ sec}}}{I_{\text{max prim}}} \right)^2$$

It is important to note, however, that the longer the effective duration, the less accurate the result.

Example: Cable and current transformer with the following data:

Permissible continuous current $I_{\text{max}} = 322 \text{ A}$ at $\theta_u = 40 \text{ °C}$

Maximum current for 1 s $I_{1\text{s}} = 45 \cdot I_{\text{max}} = 14.49 \text{ kA}$

From this results:

$$\tau_{\text{th}} = \frac{1}{60} \cdot \left(\frac{I_{1\text{s}}}{I_{\text{max}}} \right)^2 \cdot \frac{1}{60} \cdot 45^2 = 33.75 \text{ min}$$

Setting value of thermal time constant = 33.75 min

Current Limitation

To ensure that the overload protection, on occurrence of high fault currents (and with small time constants), does not result in extremely short trip times thereby perhaps affecting time grading of the fault protection, the thermal model is frozen (kept constant) as soon as the current exceeds the threshold value **1107 I MOTOR START**.

Warning Elements

By setting the thermal warning element **49 Θ ALARM** (address 4204), a warning message can be issued before reaching the tripping temperature. Tripping can thus be avoided by initiating early load reduction measures. This warning element simultaneously represents the dropout level for the trip signal. Only when this threshold is undershot, the tripping command will be reset and the protected equipment can be switched on again.

The thermal element level is given in % of the tripping overtemperature.

A current warning level is also available (parameter 4205 **I ALARM**). The setting is set as the secondary current in A (mperes) and should be equal to or slightly less than the permissible current $k \cdot I_{N\ sec}$.. It can be used instead of the thermal warning element by setting the thermal warning element to 100 % thus virtually disabling it

Dropout Time after Emergency Start

This function is not required for protection of lines and cables. Since it is activated by a binary input message, parameter **T EMERGENCY** (address 4208) is not in effect. The factory setting can be retained.

2.10.3 Settings

Addresses which have an appended "A" can only be changed with DIGSI, under "Display Additional Settings".

The table indicates region-specific default settings. Column C (configuration) indicates the corresponding secondary nominal current of the current transformer.

Addr.	Parameter	C	Setting Options	Default Setting	Comments
4201	FCT 49		OFF ON Alarm Only	OFF	49 Thermal overload protection
4202	49 K-FACTOR		0.10 .. 4.00	1.10	49 K-Factor
4203	TIME CONSTANT		1.0 .. 999.9 min	100.0 min	Time Constant
4204	49 Θ ALARM		50 .. 100 %	90 %	49 Thermal Alarm Stage
4205	I ALARM	1A	0.10 .. 4.00 A	1.00 A	Current Overload Alarm Setpoint
		5A	0.50 .. 20.00 A	5.00 A	
4207A	K τ -FACTOR		1.0 .. 10.0	1.0	K τ -FACTOR when motor stops
4208A	T EMERGENCY		10 .. 15000 sec	100 sec	Emergency time

2.10.4 Information List

No.	Information	Type of Information	Comments
1503	>BLOCK 49 O/L	SP	>BLOCK 49 Overload Protection
1507	>EmergencyStart	SP	>Emergency start of motors
1511	49 O / L OFF	OUT	49 Overload Protection is OFF
1512	49 O/L BLOCK	OUT	49 Overload Protection is BLOCKED
1513	49 O/L ACTIVE	OUT	49 Overload Protection is ACTIVE
1515	49 O/L I Alarm	OUT	49 Overload Current Alarm (I alarm)
1516	49 O/L Θ Alarm	OUT	49 Overload Alarm! Near Thermal Trip
1517	49 Winding O/L	OUT	49 Winding Overload
1521	49 Th O/L TRIP	OUT	49 Thermal Overload TRIP
1580	>RES 49 Image	SP	>49 Reset of Thermal Overload Image
1581	49 Image res.	OUT	49 Thermal Overload Image reset

2.11 Monitoring Functions

The device features comprehensive monitoring functions which cover both hardware and software. The measured values too are continuously checked for plausibility so that the current and voltage transformer circuits are largely included into the monitoring system.

2.11.1 Measurement Supervision

2.11.1.1 General

The device monitoring extends from the measuring inputs to the binary outputs. Monitoring checks the hardware for malfunctions and abnormal conditions.

Hardware and software monitoring described in the following are enabled continuously. Settings (including the possibility to activate and deactivate the monitoring function) refer to the monitoring of external transformer circuits.

2.11.1.2 Hardware Monitoring

Voltages

Failure or switch-off of the supply voltage shuts off the device; an annunciation is output via a normally closed contact. Brief auxiliary voltage interruptions of less than 50 ms do not disturb the readiness of the device (for nominal auxiliary voltage > 110 V-).

Buffer Battery

The buffer battery - which ensures operation of the internal clock and storage of counters and annunciations if the auxiliary voltage fails - is periodically checked for its charge status. If there is less than the allowed minimum voltage, the annunciation „Fail Battery“ is output.

Memory Components

All working memories (RAM) are checked during system start-up. If a malfunction occurs during that, the start-up sequence is interrupted and an LED blinks. During operation, the memories are checked with the help of their checksum. For the program memory, the cross sum is formed cyclically and compared to the stored program cross sum.

For the settings memory, the cross sum is formed cyclically and compared to the cross sum that is freshly generated each time a setting process has taken place.

If a malfunction occurs, the processor system is restarted.

Sampling

Sampling and synchronism between the internal buffer components are monitored constantly. If any occurring deviations cannot be removed by renewed synchronization, the processor system is restarted.

Measurement Value Acquisition – Currents

The monitoring of the device-internal measured-value acquisition of the currents can be effected via the current sum monitoring.

Up to four input currents are measured by the device. If the three phase currents and the ground current from the current transformer neutral point are connected with the device, the sum of the four digitized currents must be zero. This also applies in the event of a possible transformer saturation. For that reason – in order to eliminate pickup upon transformer saturation – this function is only available in a Holmgreen-connection (see also Section 2.1.3.2). Faults in the current circuits are recognized if

$$I_F = |i_A + i_B + i_C + i_E| > \Sigma I \text{ THRESHOLD} + \Sigma I \text{ FACTOR} \cdot \Sigma |I|$$

$\Sigma I \text{ THRESHOLD}$ (address 8106) and $\Sigma I \text{ FACTOR}$ (address 8107) are setting parameters. The component $\Sigma I \text{ FACTOR} \cdot \Sigma |I|$ takes into account the permissible current proportional ratio errors of the input transducers which are particularly prevalent during large short-circuit currents (Figure 2-69). The dropout ratio is about 97 %.

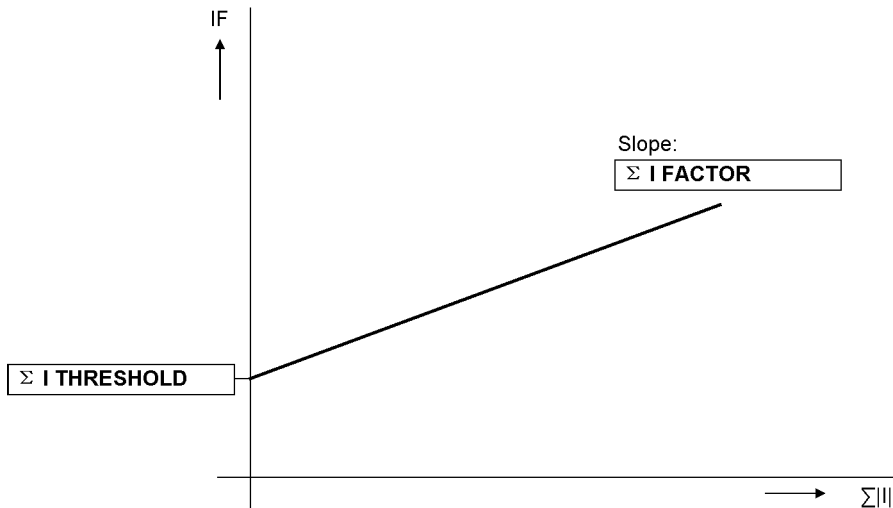

Figure 2-69 Current sum monitoring

An error in the current sum results in the message „Failure ΣI “ (No. 162) and blocking of the protection function. Furthermore, a fault log is initiated for a period of 100 ms.

The monitoring can be switched off.

The monitoring is available subject to the following conditions:

- The three phase currents are connected to the device (address 251 **A, B, C, (Gnd)**)
- The ground current of the current transformer neutral point is connected to the fourth current input (I_4) (Holmgreen-connection). This is communicated to the device in the **Power System Data 1** via address 280 **YES**.
- The fourth current input is normally designed for a I_4 -transformer. In case of a sensitive transformer type, this monitoring is not available.
- The settings **CT PRIMARY** (address 204) and **Ignd-CT PRIM** (address 217) must be the same.
- The settings **CT SECONDARY** (address 205) and **Ignd-CT SEC** (address 218) must be the same.

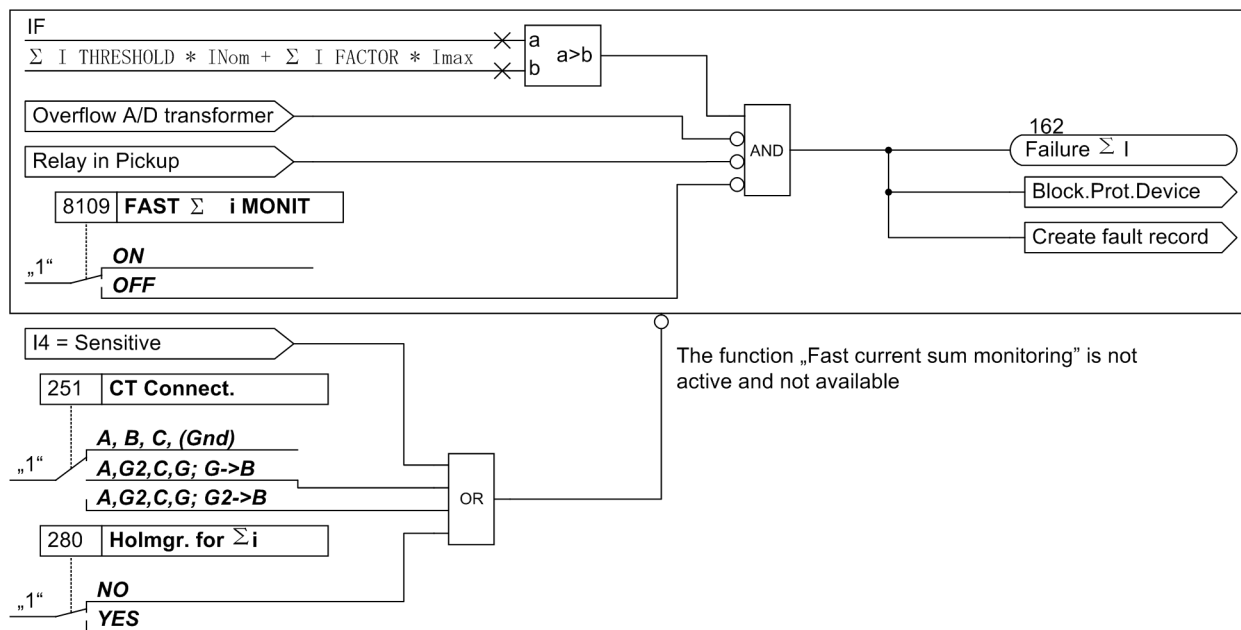

Figure 2-70 Logic Diagram of the fast current sum monitoring



Note

If the current input IN is configured as a sensitive transformer or if the connection mode **A, G2, C, G; G->B** or **A, G2, C, G; G2->B** was set for the current transformers at parameter 251 **CT Connect.**, current sum monitoring is not possible.

AD Transformer Monitoring

The digitized sampled values are being monitored in respect of their plausibility. If the result is not plausible, message 181 „Error A/D-conv.“ is issued. The protection is blocked, thus preventing unwanted operation. Furthermore, a fault record is generated for recording of the internal fault.

2.11.1.3 Software Monitoring

Watchdog

For continuous monitoring of the program sequences, a time monitor is provided in the hardware (hardware watchdog) that expires upon failure of the processor or an internal program, and causes a complete restart of the processor system.

An additional software watchdog ensures that malfunctions during the processing of programs are discovered. This also initiates a restart of the processor system.

If such a malfunction is not cleared by the restart, an additional restart attempt is begun. After three unsuccessful restarts within a 30 second window of time, the device automatically removes itself from service and the red „Error“ LED lights up. The readiness relay drops out and indicates „device malfunction“ with its normally closed contact.

Offset Monitoring

This monitoring function checks all ring buffer data channels for corrupt offset replication of the analog/digital transformers and the analog input paths using offset filters. Possible offset errors are detected using DC filters, and the associated sampled values are corrected up to a specific limit. If this limit is exceeded, an indication is generated (191 „Error Offset“) and integrated into the warning group indication (160). As increased offset values impair the measurements, we recommend sending the device to the OEM plant for corrective action should this indication persist.

2.11.1.4 Monitoring of the Transformer Circuits

Open circuits or short circuits in the secondary circuits of the current and voltage transformers, as well as faults in the connections (important during commissioning!), are detected and reported by the device. The measured quantities are periodically checked in the background for this purpose, as long as no system fault is present.

Current Symmetry

During normal system operation, symmetry among the input currents is expected. The monitoring of the measured values in the device checks this balance. The smallest phase current is compared to the largest phase current. Asymmetry is detected if $|I_{min}| / |I_{max}| < \text{BAL. FACTOR I}$ as long as $I_{max} > \text{BALANCE I LIMIT}$ is valid.

Thereby I_{max} is the largest of the three phase currents and I_{min} the smallest. The symmetry factor **BAL. FACTOR I** (address 8105) represents the allowable asymmetry of the phase currents while the limit value (address 8104) is the lower limit of the operating range of this monitoring (see Figure 2-71). Both parameters can be set. The dropout ratio is about 97 %.

This failure is thus located below the curve for all values and is reported as „Fail I balance“.

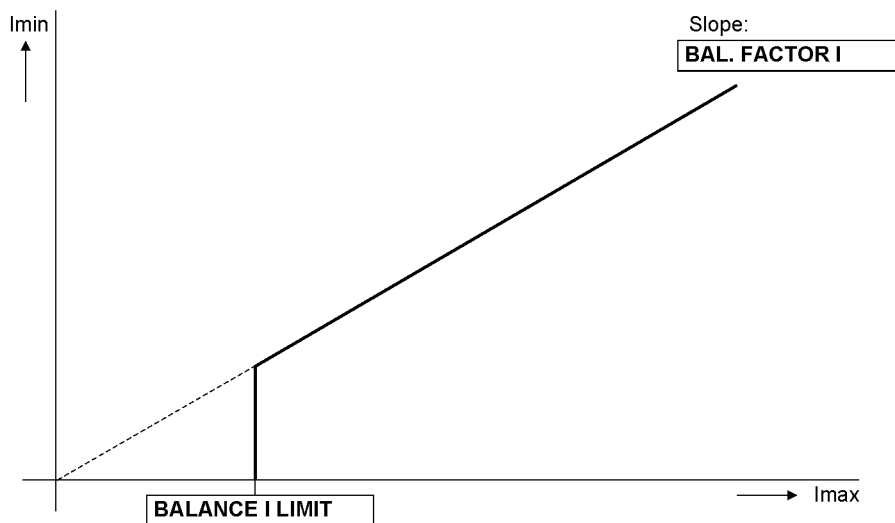

Figure 2-71 Current symmetry monitoring

Voltage Symmetry

In healthy network operation it can be expected that the voltages are nearly balanced. Because the phase-to-phase voltages are insensitive to ground faults, the phase-to-phase voltages are used for the symmetry monitoring. Depending of the connection mode, either the measured quantities or the calculated phase-to-phase voltages are used. From the phase-to-phase voltages, the rectified average values are generated and checked for symmetry of their values. The smallest phase voltage is compared with the largest phase voltage.

Imbalance is detected if

$|V_{\min}| / |V_{\max}| < \text{BAL. FACTOR V}$ as long as $|V_{\max}| > \text{BALANCE V-LIMIT}$. Where V_{\max} is the highest of the three voltages and V_{\min} the smallest. The symmetry factor **BAL. FACTOR V** (address 8103) represents the allowable asymmetry of the conductor voltages while the limit value **BALANCE V-LIMIT** (address 8102) is the lower limit of the operating range of this monitoring (see Figure 2-72). Both parameters can be set. The dropout ratio is about 97%.

This failure is thus located below the curve for all values and is reported as „Fail V balance“.

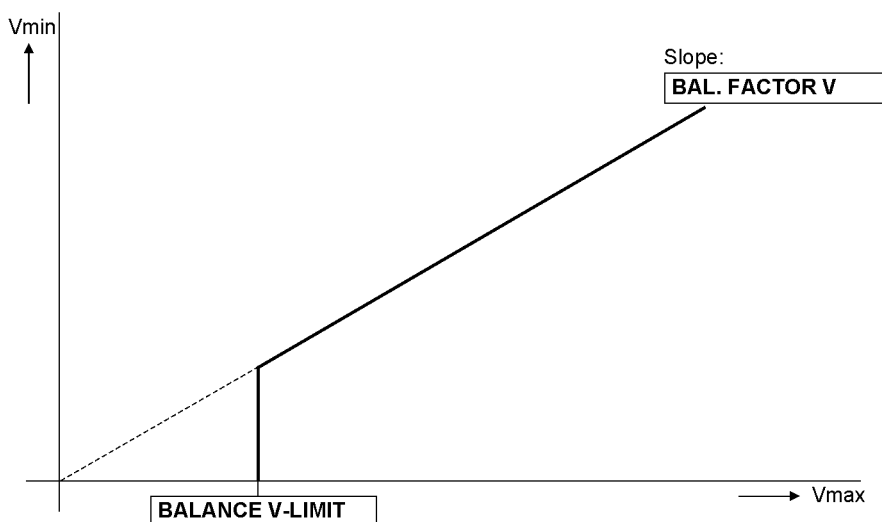

Figure 2-72 Voltage symmetry monitoring



Note

If the connection mode **Vph-g**, **VSyn** was set for the voltage transformers at parameter 213 **VT Connect. 3ph**, voltage symmetry monitoring is not possible.

Phase Sequence of Voltage and Current

To detect swapped phase connections in the voltage and current input circuits, the phase sequence of the phase-to-phase measured voltages and the phase currents are checked by monitoring the sequence of same polarity zero crossing of the voltages.

Direction measurement with normal voltages, path selection for fault location, and negative sequence detection all assume a phase sequence of "abc". Phase rotation of measurement quantities is checked by verifying the phase sequences. For that purpose, the phase-sequence monitoring uses the phase-to-phase voltages V_{AB} , V_{BC} , V_{CA} .

Voltages: V_{AB} before V_{BC} before V_{CA} and

Currents: I_A before I_B before I_C .

Verification of the voltage phase rotation is done when each measured voltage is at least

$$|V_{AB}|, |V_{BC}|, |V_{CA}| > 40 \text{ V.}$$

Verification of the current phase rotation is done when each measured current is at least:

$$|I_A|, |I_B|, |I_C| > 0.5 I_{Nom.}$$

For abnormal phase sequences, the messages „Fail Ph. Seq. V“ or „Fail Ph. Seq. I“ are issued, along with the switching of this message „Fail Ph. Seq.“.

For applications in which an opposite phase sequence is expected, the protective relay should be adjusted via a binary input or the respective parameter **PHASE SEQ.** (address 209). If the phase sequence is changed in the relay, phases B and C internal to the relay are reversed, and the positive and negative sequence currents are thereby exchanged (see also Section 2.21.2). The phase-related messages, malfunction values, and measured values are not affected by this.

2.11.1.5 Measuring Voltage Failure Detection

Requirements

The measuring voltage failure detection function - referred to as Fuse Failure Monitor (FFM) - only operates if parameter 213 **VT Connect. 3ph** is set to **Van, Vbn, Vcn** or **Vab, Vbc, VGnd**. With all other voltage transformer connection modes, FFM is not operative.

With a capacitive voltage connection, FFM and broken wire monitoring of the voltage transformer circuits are not available.

Tasks of the Fuse Failure Monitor

In the case of a measuring voltage failure caused by a short-circuit or broken wire in the secondary voltage transformer system, a zero voltage can be simulated to individual measuring loops.

The displacement voltage element of the (sensitive) ground fault detection, the directional overcurrent protection and the undervoltage protection can thereby acquire incorrect measuring results.

The blocking of this function by the FFM is configurable.

The FFM can become effective in grounded as well as in isolated systems provided that the connection mode **Van, Vbn, Vcn** or **Vab, Vbc, VGnd** was set. Of course, the miniature circuit breaker and FFM can also be used for the detection of a measuring voltage failure at the same time.

Mode of Operation - Grounded System

The device is informed of the application of the FFM in the grounded system via address 5301 **FUSE FAIL MON. Solid grounded**.



Note

On systems where ground fault current is very small or absent (e.g. ungrounded supply transformers), fuse failure monitoring must be disabled or set to **Coil.gnd./isol..**

The logic diagram on the mode of operation in a grounded system is illustrated in Figure 2-73. Depending on the configuration and MLFB, the FFM operates with measured or calculated values V_N or I_N . If a zero sequence voltage occurs without a ground fault current being registered simultaneously, this suggests an asymmetrical fault in the secondary voltage transformer circuit.

The displacement voltage element of the (sensitive) ground fault detection, the directional overcurrent protection (phase and ground function) and the undervoltage protection are blocked if parameter 5310 **BLOCK PROT.** is set to **YES**.

The FFM picks up if the ground voltage V_N is higher than the limit value set at 5302 **FUSE FAIL 3Vo** and if the ground current I_N is smaller than the limit value set at 5303 **FUSE FAIL RESID**.

Pickup occurs at the configured values. A hysteresis for the dropout of 105% is integrated for I_N or 95% for V_N . In the case of a low-current asymmetrical fault in a system with weak infeed, the ground current caused by the

fault could lie below the pickup threshold of the FFM. An overfunctioning of the FFM can, however, cause the feeder protection device to underfunction since all protection functions that use voltage signals are blocked. In order to prevent such an overfunctioning of the FFM, the phase currents are also checked. If at least one phase current lies above the pickup threshold of 5303 **FUSE FAIL RESID**, it can be assumed that the zero current created by a short-circuit equally exceeds this threshold.

In order to immediately detect an existing fault after connection, the following applies: If a ground current I_N larger than the pickup threshold of 5303 **FUSE FAIL RESID** is detected within 10 seconds after recognition of the fuse failure criterion, the protection assumes a short-circuit and removes the blocking by the FFM for the duration of the fault. Whereas if the voltage failure criterion is present for more than about 10 seconds, the blocking is permanently active. After this time has elapsed, it can be assumed that a fuse failure has actually occurred. Only 10 seconds after the voltage criterion was removed by correction of the secondary circuit failure, is the blocking automatically reset, thereby releasing the blocked protection functions.

The generation of the internal signal „Alarm FFM“ for the mode of operation in an isolated system is illustrated in Figure 2-74.

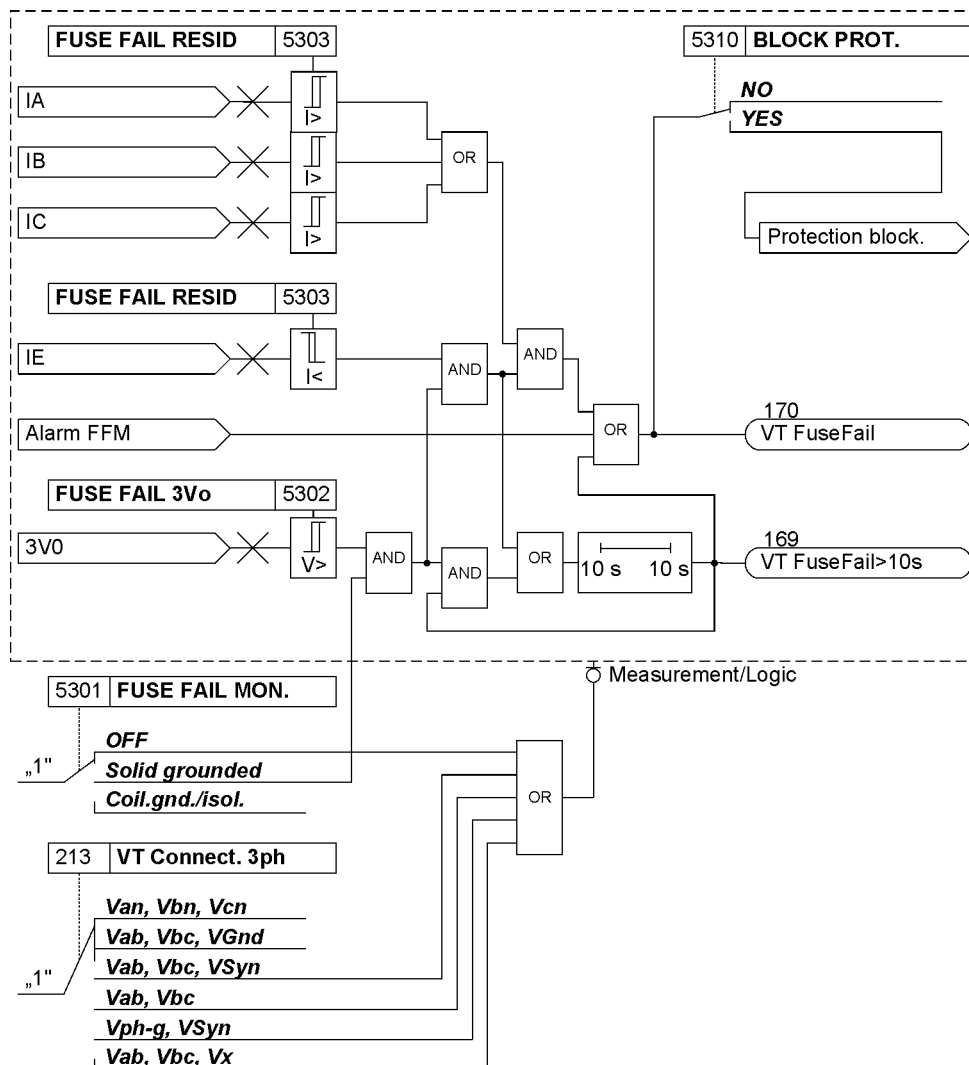

Figure 2-73 Logic diagram of the fuse failure monitor for grounded networks

Mode of Operation - Isolated System and 3-pole Fuse Failure

The FFM can also operate in isolated and compensated (resonant-grounded) systems where only low ground currents are to be expected. The device is informed of that via address 5301 **FUSE FAIL MON..**

The logic diagram on the mode of operation in an isolated system and for 3-pole fuse failure is illustrated in Figure 2-74. The following is a description of the principles for single-, two- and three-pole faults in a secondary voltage transformer system. If this part of the FFM logic picks up, the internal signal „Alarm FFM“ is generated, the further processing of which is indicated in Figure 2-73.

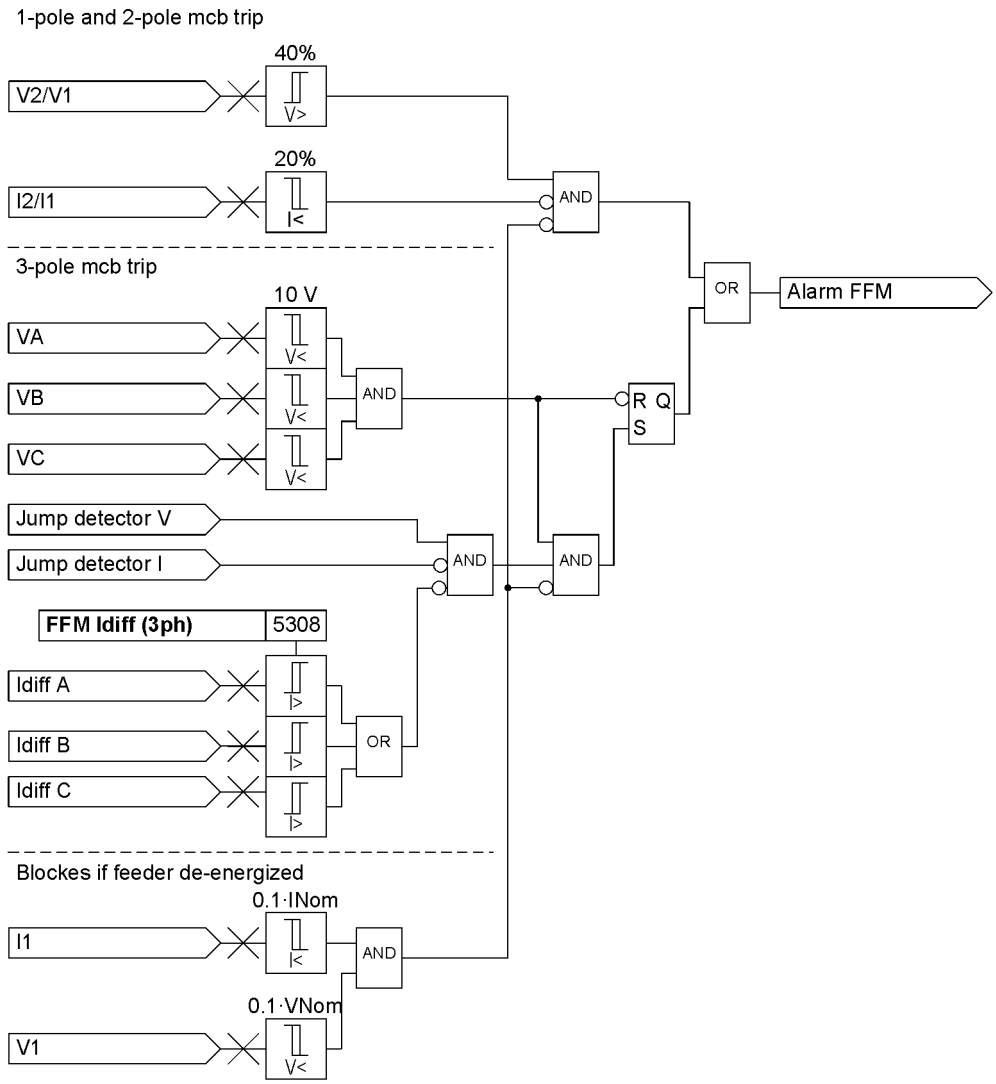

Figure 2-74 Logic diagram of the Fuse Failure Monitor for isolated systems

Single- and Two-phase Failures in Voltage Transformer Circuits

The measuring voltage failure detection is based on the fact that a significant negative sequence system is formed in the voltage during single- or two-phase voltage failure, however without influencing the current. This enables a clear distinction from asymmetries impressed by the power system. If the negative sequence system is related to the current positive sequence system, the following rules apply to the **Fault-free Case**:

$$\frac{V_2}{V_1} = 0 \quad \text{and} \quad \frac{I_2}{I_1} = 0$$

If a fault occurs in the voltage transformer secondary system, the following rules apply to the **Single-phase Failure**:

$$\frac{V_2}{V_1} = \frac{0.33}{0.66} = 0.5 \quad \text{and} \quad \frac{I_2}{I_1} = 0 \quad \left(\frac{V_2}{V_1} > \frac{I_2}{I_1} \right)$$

If a fault occurs in the voltage transformer secondary system, the following rules apply to the **Two-phase Failure**:

$$\frac{V_2}{V_1} = \frac{0.33}{0.33} = 1 \quad \text{and} \quad \frac{I_2}{I_1} = 0 \quad \left(\frac{V_2}{V_1} > \frac{I_2}{I_1} \right)$$

In case of a failure of one or two phases of the primary system, the current also shows a negative sequence system of 0.5 or 1. Consequently, the voltage monitoring does not respond since no voltage transformer fault can be present. In order to avoid occurrence of an overfunctioning of the measuring voltage failure detection due to inaccuracy, the function is blocked below a minimum threshold of the positive sequence systems of voltage ($V_1 < 0.1 V_{\text{Nom}}$) and current ($I_1 < 0.1 I_{\text{Nom}}$).

Three-phase Failures in Voltage Transformer Circuits

A 3-phase failure in the voltage transformer secondary system cannot be detected via the positive- and negative-sequence system as described above. The monitoring of the progress of current and voltage over time is required here. If a voltage dip to almost zero occurs (or if the voltage is zero), and the current remains unchanged, a 3-phase failure in the voltage transformer secondary system can be concluded. The jump detection is used for this purpose. The sensitivity of the jump detection for current can be increased via parameter **FFM Idiff (3ph)**.

2.11.1.6 Broken Wire Monitoring of Voltage Transformer Circuits

Requirements

This function is only available in device version „World“ (Ordering Information Pos. 10 = B) since it is only used in certain regions. Furthermore, the measurement of all three phase-to-ground voltages (**V_{an}**, **V_{bn}**, **V_{cn}**) is a requirement. If only two phase-to-phase voltages were measured, it would not be possible to evaluate two of the required criteria.

Task

The broken wire function monitors the voltage transformer circuits of the secondary system with regard to failure. A distinction is made between single-pole, two-pole and three-pole failures.

Mode of Operation / Logic

The values required for the respective criteria are calculated from the calculated displacement voltage and the measured three phase currents and a decision is made. The resulting alarm message may be delayed. A blocking of the protection functions is however not effected. This is done by the measuring voltage failure detection.

The broken wire monitoring is also active during a fault. The function may be enabled or disabled.

The following logic diagram shows how the broken wire monitoring functions.

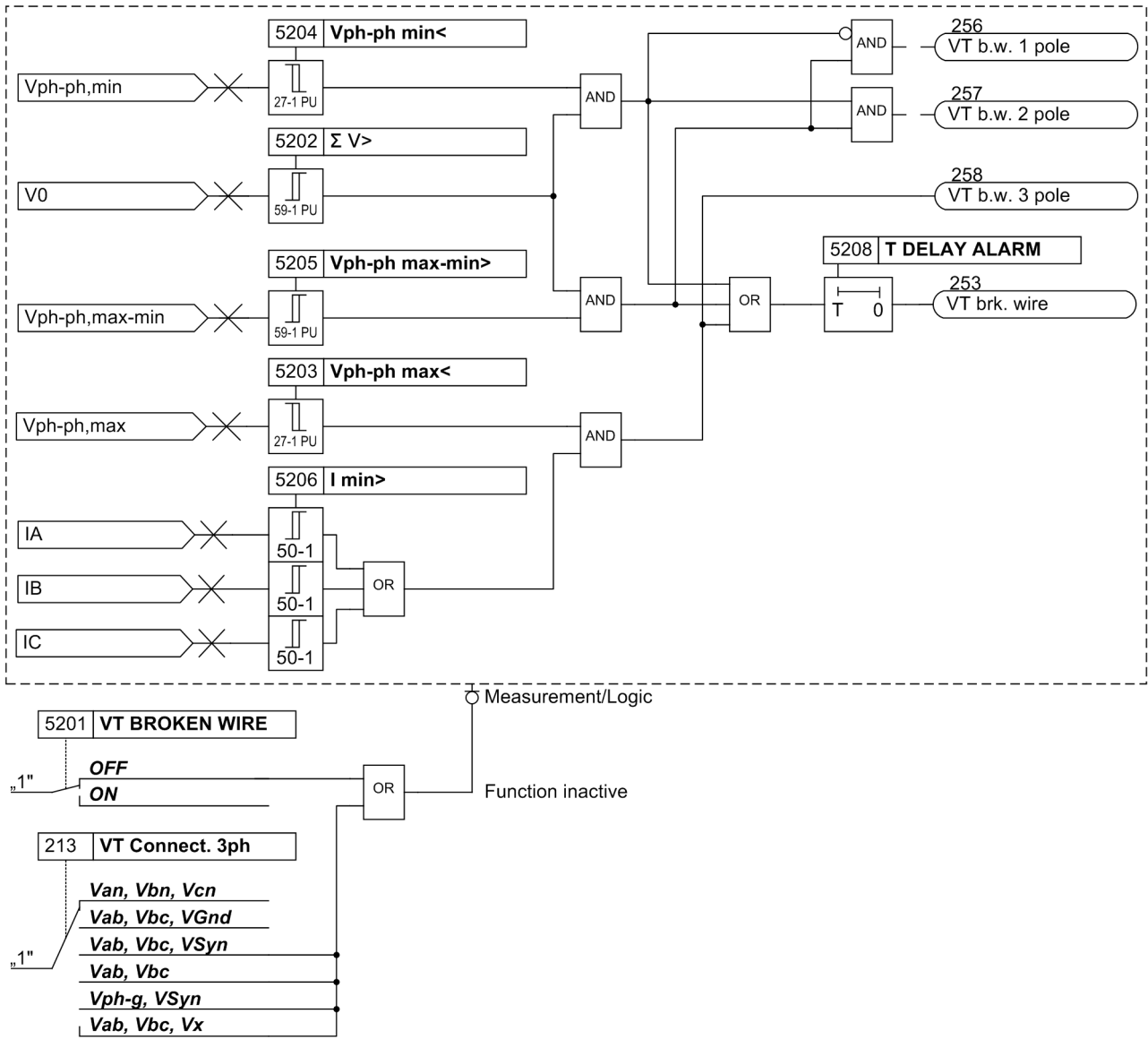

Figure 2-75 Logic diagram of the broken wire monitoring

2.11.1.7 Setting Notes

Measured Value Monitoring

The sensitivity of measured value monitor can be modified. Default values which are sufficient in most cases are preset. If especially high operating asymmetries in the currents and/or voltages are to be expected during operation, or if it becomes apparent during operation that certain monitoring functions activate sporadically, then the setting should be less sensitive.

Address 8102 **BALANCE V-LIMIT** determines the limit voltage (phase-to-phase) above which the voltage symmetry monitoring is effective. Address 8103 **BAL. FACTOR V** is the associated balance factor; that is, the slope of the symmetry characteristic.

Address 8104 **BALANCE I LIMIT** determines the limit current above which the current symmetry monitoring is effective. Address 8105 **BAL. FACTOR I** is the associated balance factor; that is, the slope of the symmetry characteristic.

Address 8106 Σ **I THRESHOLD** determines the limit current above which the current sum monitoring is activated (absolute portion, only relative to I_{Nom}). The relative portion (relative to the maximum conductor current) for activating the current sum monitor is set at address 8107 Σ **I FACTOR**.



Note

Current sum monitoring can operate properly only when the residual current of the protected line is fed to the fourth current input (I_N) of the relay (see **Power System Data 1**). Furthermore, the fourth current input (I_N) may not be sensitive.



Note

The connections of the ground paths and their adaption factors were set when configuring the general Power System Data. These settings must be correct for the measured values monitoring to function properly.

Measured value monitoring can be set to **ON** or **OFF** at address 8101 **MEASURE. SUPERV.**

Fuse Failure Monitor (FFM)

Via address 5301 **FUSE FAIL MON.** you select under which system conditions the FFM works. Depending on that, make the required settings in the grounded system via the parameters 5302, 5303 and 5307. In a grounded/isolated system, only the parameter 5307 is relevant.

The settings for the fuse failure monitor must be selected in such manner that reliable activation occurs if a phase voltage fails, but that false activation does not occur during ground faults in a grounded network. Address 5303 **FUSE FAIL RESID** must be set as sensitive as required (with ground faults, below the smallest fault current).

The FFM picks up if the ground voltage V_N is higher than the set limit value under address 5302 **FUSE FAIL 3Vo** and if the ground current I_N lies below the set limit value under address 5303 **FUSE FAIL RESID**.

In order to detect a three-phase failure, the progress in time of current and voltage is monitored. If the voltage sinks below the threshold value without a change in the current value, a three-phase failure is detected. This threshold value of the current element must be set under address 5307 **I> BLOCK**. The threshold value should be identical with the definite time overcurrent protection.

Under address 5310 **BLOCK PROT.** it can be determined whether the protection functions should be blocked upon pickup by the FFM.



Note

The setting under address 5310 **BLOCK PROT.** has no effect on the flexible protection functions. A separate blocking can be selected for that purpose.

The function may be disabled in address 5301 **FUSE FAIL MON.**, e.g. when performing asymmetrical tests.

2.11.1.8 Settings

Addresses which have an appended "A" can only be changed with DIGSI, under "Display Additional Settings".

The table indicates region-specific default settings. Column C (configuration) indicates the corresponding secondary nominal current of the current transformer.

Addr.	Parameter	C	Setting Options	Default Setting	Comments
5201	VT BROKEN WIRE		ON OFF	OFF	VT broken wire supervision
5202	$\Sigma V >$		1.0 .. 100.0 V	8.0 V	Threshold voltage sum
5203	Vph-ph max<		1.0 .. 100.0 V	16.0 V	Maximum phase to phase voltage
5204	Vph-ph min<		1.0 .. 100.0 V	16.0 V	Minimum phase to phase voltage
5205	Vph-ph max-min>		10.0 .. 200.0 V	16.0 V	Symmetry phase to phase voltages
5206	I min>	1A	0.04 .. 1.00 A	0.04 A	Minimum line current
		5A	0.20 .. 5.00 A	0.20 A	
5208	T DELAY ALARM		0.00 .. 32.00 sec	1.25 sec	Alarm delay time
5301	FUSE FAIL MON.		OFF Solid grounded Coil.gnd./isol.	OFF	Fuse Fail Monitor
5302	FUSE FAIL 3Vo		10 .. 100 V	30 V	Zero Sequence Voltage
5303	FUSE FAIL RESID	1A	0.10 .. 1.00 A	0.10 A	Residual Current
		5A	0.50 .. 5.00 A	0.50 A	
5308A	FFM Idiff (3ph)	1A	0.05 .. 1.00 A	0.10 A	Differential Current Threshold (3phase)
		5A	0.25 .. 5.00 A	0.50 A	
5310	BLOCK PROT.		NO YES	YES	Block protection by FFM
8101	MEASURE. SUPERV		OFF ON	ON	Measurement Supervision
8101	MEASURE. SUPERV		OFF ON	OFF	Measurement Supervision (For CEI 0-16)
8102	BALANCE V-LIMIT		10 .. 100 V	50 V	Voltage Threshold for Balance Monitoring
8103	BAL. FACTOR V		0.58 .. 0.90	0.75	Balance Factor for Voltage Monitor

Addr.	Parameter	C	Setting Options	Default Setting	Comments
8104	BALANCE I LIMIT	1A	0.10 .. 1.00 A	0.50 A	Current Threshold for Balance Monitoring
		5A	0.50 .. 5.00 A	2.50 A	
8105	BAL. FACTOR I		0.10 .. 0.90	0.50	Balance Factor for Current Monitor
8106	Σ I THRESHOLD	1A	0.05 .. 2.00 A; ∞	0.10 A	Summated Current Monitoring Threshold
		5A	0.25 .. 10.00 A; ∞	0.50 A	
8107	Σ I FACTOR		0.00 .. 0.95	0.10	Summated Current Monitoring Factor
8109	FAST Σ i MONIT		OFF ON	ON	Fast Summated Current Monitoring
8110A	T BAL. V LIMIT		0 .. 100 sec	5 sec	T Balance Factor for Voltage Monitor
8111A	T BAL. I LIMIT		0 .. 100 sec	5 sec	T Current Balance Monitor

2.11.1.9 Information List

No.	Information	Type of Information	Comments
161	Fail I Superv.	OUT	Failure: General Current Supervision
162	Failure Σ I	OUT	Failure: Current Summation
163	Fail I balance	OUT	Failure: Current Balance
167	Fail V balance	OUT	Failure: Voltage Balance
169	VT FuseFail>10s	OUT	VT Fuse Failure (alarm >10s)
170	VT FuseFail	OUT	VT Fuse Failure (alarm instantaneous)
171	Fail Ph. Seq.	OUT	Failure: Phase Sequence
175	Fail Ph. Seq. I	OUT	Failure: Phase Sequence Current
176	Fail Ph. Seq. V	OUT	Failure: Phase Sequence Voltage
197	MeasSup OFF	OUT	Measurement Supervision is switched OFF
253	VT brk. wire	OUT	Failure VT circuit: broken wire
255	Fail VT circuit	OUT	Failure VT circuit
256	VT b.w. 1 pole	OUT	Failure VT circuit: 1 pole broken wire
257	VT b.w. 2 pole	OUT	Failure VT circuit: 2 pole broken wire
258	VT b.w. 3 pole	OUT	Failure VT circuit: 3 pole broken wire
6509	>FAIL:FEEDER VT	SP	>Failure: Feeder VT
6510	>FAIL: BUS VT	SP	>Failure: Busbar VT

2.11.2 Trip Circuit Supervision 74TC

The 7SJ80 is equipped with an integrated trip circuit supervision. Depending on the number of available binary inputs (not connected to a common potential), supervision with one or two binary inputs can be selected. If the allocation of the required binary inputs does not match the selected supervision type, a message to this effect is generated („74TC ProgFail“).

Applications

- When using two binary inputs, malfunctions in the trip circuit can be detected under all circuit breaker conditions.
- When only one binary input is used, malfunctions in the circuit breaker itself cannot be detected.

Prerequisites

A requirement for the use of trip circuit supervision is that the control voltage for the circuit breaker is at least twice the voltage drop across the binary input ($V_{ct} > 2 \cdot V_{BImin}$).

Since at least 19 V are needed for the binary input, the monitor can only be used with a system control voltage of over 38 V.

2.11.2.1 Description

Supervision with Two Binary Inputs

When using two binary inputs, these are connected according to Figure 2-76, parallel to the associated trip contact on one side, and parallel to the circuit breaker auxiliary contacts on the other.

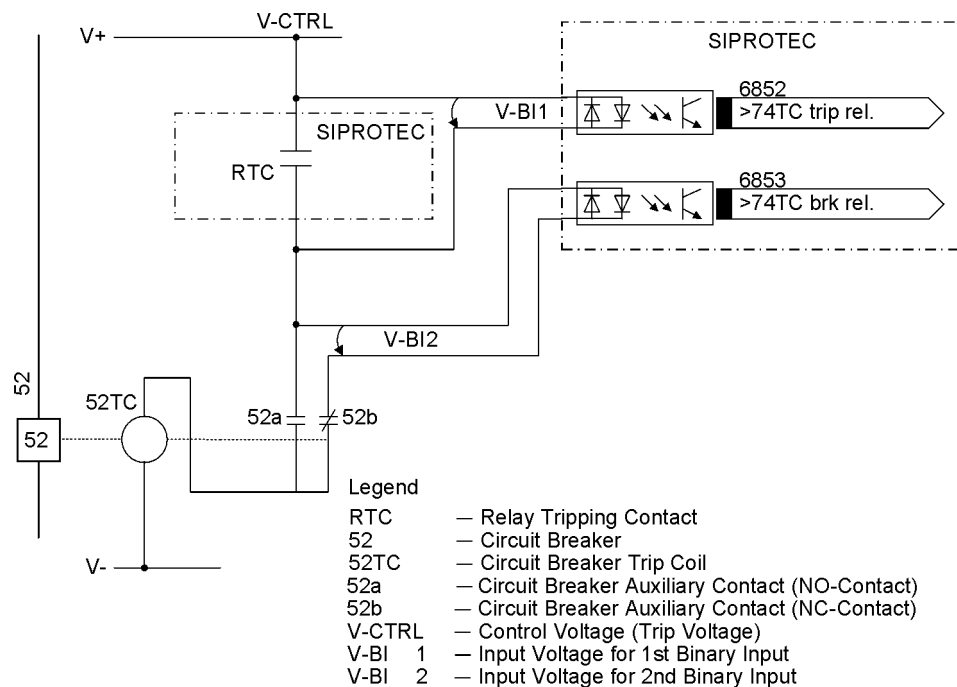

Figure 2-76 Principle of the trip circuit supervision with two binary inputs

Supervision with two binary inputs not only detects interruptions in the trip circuit and loss of control voltage, it also supervises the response of the circuit breaker using the position of the circuit breaker auxiliary contacts.

Depending on the conditions of the trip contact and the circuit breaker, the binary inputs are activated (logical condition "H" in Table 2-11), or not activated (logical condition "L").

In healthy trip circuits the condition that both binary inputs are not actuated ("L") is only possible during a short transition period (trip contact is closed but the circuit breaker has not yet opened). A continuous state of this condition is only possible when the trip circuit has been interrupted, a short-circuit exists in the trip circuit, a loss of battery voltage occurs, or malfunctions occur with the circuit breaker mechanism. Therefore, it is used as supervision criterion.

Table 2-11 Condition table for binary inputs, depending on RTC and CB position

No.	Trip contact	Circuit breaker	52a Contact	52b Contact	BI 1	BI 2
1	Open	Closed	Closed	Open	H	L
2	Open	Open	Open	Closed	H	H
3	Closed	Closed	Closed	Open	L	L
4	Closed	Open	Open	Closed	L	H

The conditions of the two binary inputs are checked periodically. A check takes place about every 600 ms. If three consecutive conditional checks detect an abnormality (after 1.8 s), an annunciation is reported (see Figure 2-77). The repeated measurements determine the delay of the alarm message and avoid that an alarm is output during short transition periods. After the malfunction in the trip circuit is cleared, the fault annunciation is reset automatically after the same time period.

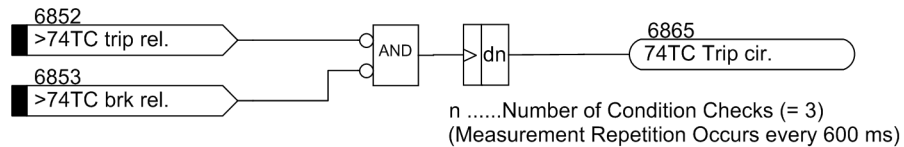

Figure 2-77 Logic diagram of the trip circuit supervision with two binary inputs

Supervision with One Binary Input

The binary input is connected according to the following figure in parallel with the associated trip contact of the protection relay. The circuit breaker auxiliary contact is bridged with a bypass resistor R.

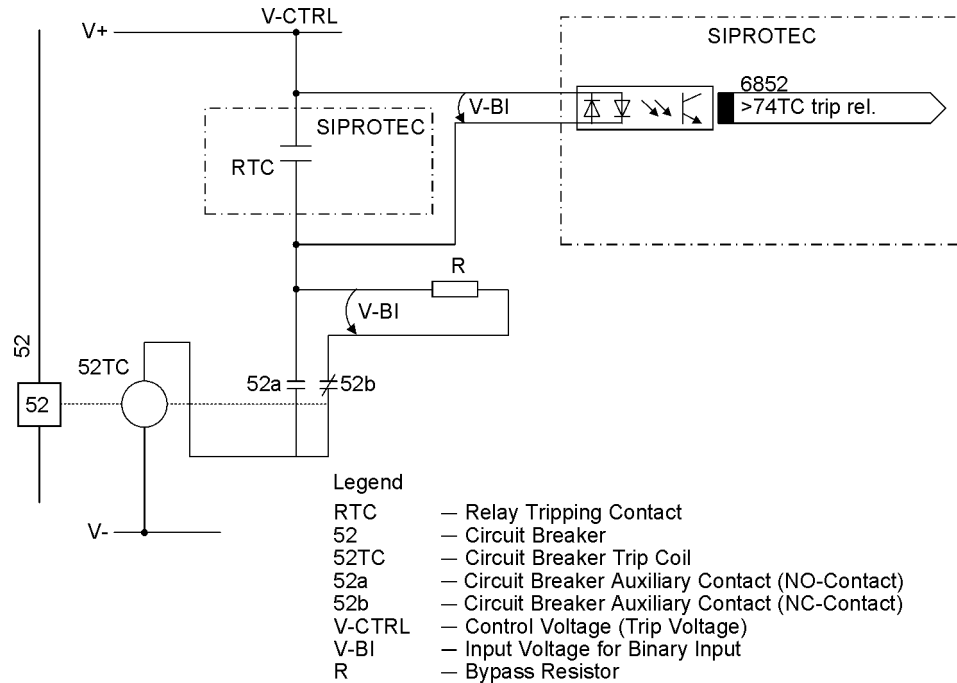

Figure 2-78 Trip circuit supervision with one binary input

During normal operation, the binary input is activated (logical condition "H") when the trip contact is open and the trip circuit is intact, because the monitoring circuit is closed by either the 52a circuit breaker auxiliary contact (if the circuit breaker is closed) or through the bypass resistor R by the 52b circuit breaker auxiliary contact. Only as long as the trip contact is closed, the binary input is short circuited and thereby deactivated (logical condition "L").

If the binary input is continuously deactivated during operation, this leads to the conclusion that there is an interruption in the trip circuit or loss of control voltage.

As the trip circuit supervision does not operate during system faults, the closed trip contact does not lead to a fault message. If, however, tripping contacts from other devices operate in parallel with the trip circuit, then the fault message must be delayed (see also Figure 2-79). The delay time can be set via parameter 8202 **Alarm Delay**. A message is only released after expiry of this time. After clearance of the fault in the trip circuit, the fault message is automatically reset.

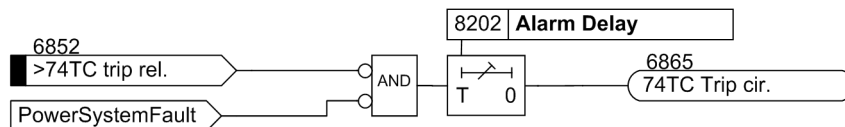

Figure 2-79 Logic diagram of trip circuit supervision with one binary input

The following figure shows the logic diagram for the message that can be generated by the trip circuit monitor, depending on the control settings and binary inputs.

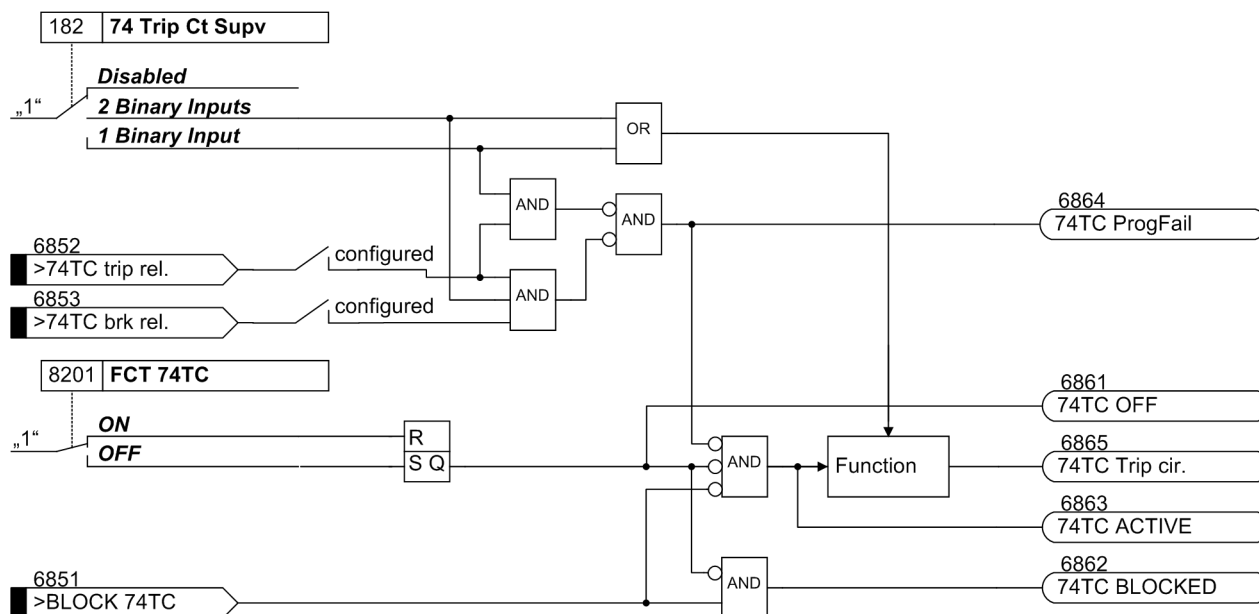

Figure 2-80 Message logic for trip circuit supervision

2.11.2.2 Setting Notes

General

The function is only effective and accessible if address 182 (Section 2.1.1.2) was set to either **2 Binary Inputs** or **1 Binary Input** during configuration, the appropriate number of binary inputs has been configured accordingly for this purpose and the function **FCT 74TC** is **ON** at address 8201. If the allocation of the required binary inputs does not match the selected supervision type, a message to this effect is generated („74TC ProgFail“). If the trip circuit monitor is not to be used at all, then **Disabled** is set at address 182.

In order to ensure that the longest possible duration of a trip command can be reliably bridged, and an indication is generated in case of an actual fault in the trip circuit, the indication regarding a trip circuit interruption is delayed. The time delay is set under address 8202 **Alarm Delay**.

Supervision with One Binary Input

Note: When using only one binary input (BI) for the trip circuit monitor, malfunctions, such as interruption of the trip circuit or loss of battery voltage are detected in general, but trip circuit failures while a trip command is active cannot be detected. Therefore, the measurement must take place over a period of time that bridges the longest possible duration of a closed trip contact. This is ensured by the fixed number of measurement repetitions and the time between the state checks.

When using only one binary input, a resistor R is inserted into the circuit on the system side, instead of the missing second binary input. Through appropriate sizing of the resistor and depending on the system conditions, a lower control voltage is mostly sufficient.

Information for dimensioning resistor R is given in the Chapter "Installation and Commissioning" under Configuration Notes in the Section "Trip Circuit Supervision".

2.11.2.3 Settings

Addr.	Parameter	Setting Options	Default Setting	Comments
8201	FCT 74TC	ON OFF	ON	74TC TRIP Circuit Supervision
8202	Alarm Delay	1 .. 30 sec	2 sec	Delay Time for alarm

2.11.2.4 Information List

No.	Information	Type of Information	Comments
6851	>BLOCK 74TC	SP	>BLOCK 74TC
6852	>74TC trip rel.	SP	>74TC Trip circuit superv.: trip relay
6853	>74TC brk rel.	SP	>74TC Trip circuit superv.: bkr relay
6861	74TC OFF	OUT	74TC Trip circuit supervision OFF
6862	74TC BLOCKED	OUT	74TC Trip circuit supervision is BLOCKED
6863	74TC ACTIVE	OUT	74TC Trip circuit supervision is ACTIVE
6864	74TC ProgFail	OUT	74TC blocked. Bin. input is not set
6865	74TC Trip cir.	OUT	74TC Failure Trip Circuit

2.11.3 Malfunction Responses of the Monitoring Functions

The malfunction responses of monitoring equipment are summarized in the following.

2.11.3.1 Description

Malfunction Responses

Depending on the type of malfunction discovered, an annunciation is sent, a restart of the processor system is initiated, or the device is shut down. After three unsuccessful restart attempts, the device is also shut down. The readiness relay opens and indicates with its NC contact that the device is malfunctioning. Moreover, the red "ERROR" LED lights up on the front cover and the green "RUN" LED goes out. If the internal auxiliary voltage also fails, all LEDs are dark. Table 2-12 shows a summary of the monitoring functions and the malfunction responses of the device.

Table 2-12 Summary of the device's malfunction responses

Monitoring	Possible causes	Malfunction response	Annunciation (No.)	Output
Auxiliary voltage failure	External (auxiliary voltage) Internal (converter)	Device shutdown	All LEDs dark	DOK ²⁾ drops out
Buffer battery	Internal (buffer battery)	Annunciation	„Fail Battery“ (177)	
Hardware watchdog	Internal (processor failure)	Device shutdown ¹⁾	"ERROR" LED	DOK ²⁾ drops out
Software watchdog	Internal (processor failure)	Restart attempt ¹⁾	"ERROR" LED	DOK ²⁾ drops out
Working memory ROM	Internal (hardware)	Abortion of restart, device shutdown	LED flashes	DOK ²⁾ drops out
Program memory RAM	Internal (hardware)	During boot sequence	"ERROR" LED	DOK ²⁾ drops out
		During operation: restart attempt ¹⁾	"ERROR" LED	
Parameter memory	Internal (hardware)	Restart attempt ¹⁾	"ERROR" LED	DOK ²⁾ drops out
Sampling frequency	Internal (hardware)	Device shutdown	"ERROR" LED	DOK ²⁾ drops out
Error in the I/O board	Internal (hardware)	Device shutdown	„I/O-Board error“ (178), "ERROR" LED	DOK ²⁾ drops out
Offset monitoring	Internal (hardware)	Device shutdown	„Error Offset“ (191)	DOK ²⁾ drops out
Current sum	Internal (measured value acquisition)	Annunciation	„Failure Σ I“ (162)	As allocated
Current symmetry	External (system or current transformer)	Annunciation	„Fail I balance“ (163)	As allocated
Voltage symmetry	External (system or voltage transformer)	Annunciation	„Fail V balance“ (167)	As allocated
Voltage phase sequence	External (system or connection)	Annunciation	„Fail Ph. Seq. V“ (176)	As allocated
Current phase sequence	External (system or connection)	Annunciation	„Fail Ph. Seq. I“ (175)	As allocated
Fuse failure monitor	External (voltage transformer)	Annunciation	„VT FuseFail>10s“ (169) „VT FuseFail“ (170)	As allocated
Trip circuit supervision	External (trip circuit or control voltage)	Annunciation	„74TC Trip cir.“ (6865)	As allocated
Secondary voltage transformer circuit monitoring	External (voltage transformer circuit interruption)	Annunciation	"VT brk. wire" (253)	As allocated
Capacitive voltage measurement	Misconfiguration	Annunciation	„Capac.Par.Fail.“ (10036)	As allocated
Adjustment data error	Internal (hardware)	Annunciation	„Alarm NO calibr“ (193)	As allocated

¹⁾ After three unsuccessful restart attempts, the device is shut down.

²⁾ DOK = "Device okay" = readiness relay drops out, protection and control functions are blocked.

Group Annunciations

Certain annunciations of the monitoring functions are already combined to group annunciations. These group annunciations and their composition are stated in the Appendix A.10. In this context it must be noted that the annunciation 160 „Alarm Sum Event“ is only issued when the measured value monitoring functions (8101 **MEASURE** . **SUPERV**) are activated.

2.12 Ground Fault Protection 64, 67N(s), 50N(s), 51N(s)

Depending on the variant, the fourth current input of the multi-functional protection relay 7SJ80 is equipped either with a sensitive input transformer or a standard transformer for 1/5 A.

In the first case, the protective function is designed for ground fault detection in isolated or compensated systems due to its high sensitivity. It is not really suited for ground fault detection with large ground currents since the linear range is transcended at about 1.6 A at the sensitive ground fault detection relay terminals.

If the relay is equipped with a standard transformer for 1/5 A currents, large currents can also be detected correctly.

This function can operate in two modes. The standard procedure, the „cos- φ / sin- φ measurement“, evaluates the part of the ground current perpendicular to the settable directional characteristic.

The second procedure, the „U0/I0- φ measurement“, calculates the angle between ground current and displacement voltage. For this procedure, two different directional characteristics can be set.

Applications

- Sensitive ground fault detection may be used in isolated or compensated systems to detect ground faults, to determine phases affected by ground faults, and to specify the direction of ground faults.
- In solidly or low-resistance grounded systems, sensitive ground fault detection is used to detect high impedance ground faults.
- This function can also be used as supplementary ground fault protection.

The special function 59V0 for the CEI 0-16 standard is described in detail in the 81 frequency protection chapter.

2.12.1 Ground Fault Detection for cos- φ / sin- φ Measurement (Standard Method)

Voltage Element

The voltage element relies on a pickup initiated by the displacement voltage V_0 or $3 \cdot V_0$. Additionally, the faulty phase is determined. The displacement voltage V_0 can be directly applied to the device, or the summation voltage $3 \cdot V_0$ can be calculated according to the connection type of the voltage transformer (see also Parameter 213 **VT Connect. 3ph** in Section 2.1.3). When setting **Van**, **Vbn**, **Vcn**, the calculation of the summation voltage $3 \cdot V_0$ is based on the three phase-to-Ground voltages. The three voltage inputs must therefore be connected to the voltage transformers in a grounded-wye configuration. When setting **Vab**, **Vbc**, **VGnd**, the three phase-to-Ground voltages of both connected phase-to-phase voltages and the connected displacement voltage are calculated. If the device is only provided with phase-to-phase voltages, it is not possible to calculate a displacement voltage from them. In this case the direction cannot be determined.

If the displacement voltage is calculated, then:

$$3 \cdot V_0 = V_A + V_B + V_C$$

If the displacement voltage is directly applied to the device, then V_0 is the voltage at the device terminals. It is not affected by parameter **Vph** / **Vdelta** (address 206).

The voltage element is not available when using capacitive voltage measurement.

The displacement voltage is used both to detect a ground fault and to determine direction. When the voltage element picks up, a preset time delay must elapse before detection of the displacement voltage is reported to be able to record stable measurement quantities. The time delay can be configured (**T-DELAY Pickup**) and its factory setting is 1 s.

Pickup performed by the displacement voltage can be delayed (**64-1 DELAY**) for tripping.

It is important to note that the total tripping time then consists of the displacement voltage measurement time (about 50 ms) plus the pickup time delay **T-DELAY Pickup** plus the tripping delay **64-1 DELAY**.

After the voltage element picks up due to detection of a displacement voltage, the grounded phase is identified, if possible. For this purpose, the individual phase-to-Ground voltages are measured or calculated, irrespective of the connection type of the voltage transformers. If the voltage magnitude for any given phase falls below the set threshold **VPH MIN**, that phase is detected as the grounded phase as long as the remaining phase-to-Ground voltages exceed the set threshold **VPH MAX**.

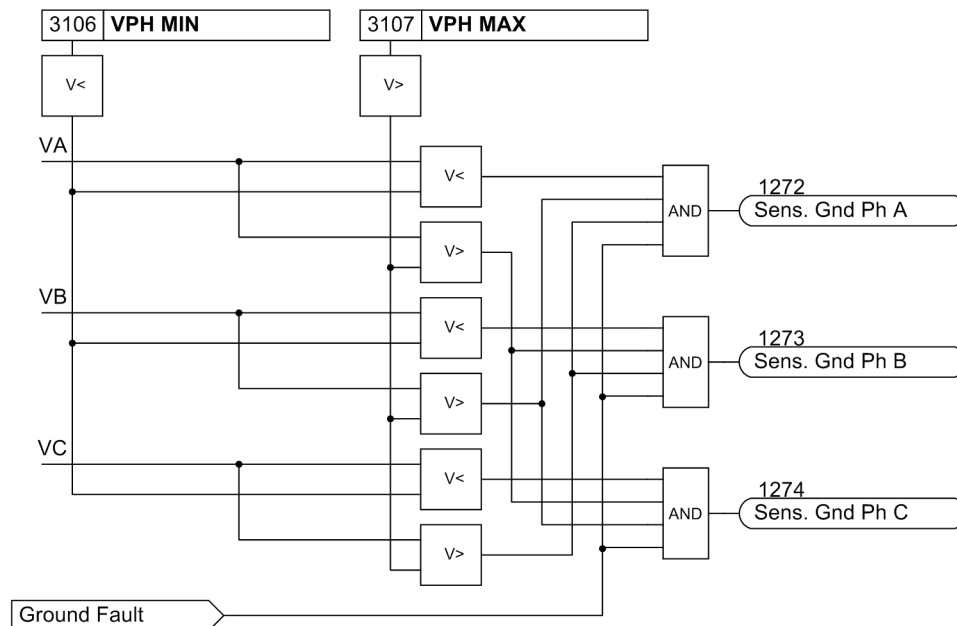

From Logic Diagram of the Sensitive Ground Fault Detection

Figure 2-81 Determination of Grounded Phase

Current Elements

The current elements for ground faults operate with the magnitudes of the ground current. It is sensible to employ them only where the magnitude of the ground current can be used to specify the ground fault. This may be the case on grounded systems (solid or low-resistance) or on electrical machines which are directly connected to the busbar of an isolated power system, when in case of a network ground fault the machine supplies only a negligible ground fault current across the measurement location, which must be situated between the machine terminals and the network, whereas in case of a machine ground fault the higher ground fault current produced by the total network is available. Ground current protection is mostly used as backup protection for high resistance ground faults in solid or low resistance grounded systems when the main fault protection does not pickup.

For ground current detection, a two-element current/time Curve can be set. Analogous to the time overcurrent protection, the high-set current stage is designated as **50Ns-2 PICKUP** and **50Ns-2 DELAY** and is provided with a definite time characteristic. The overcurrent element may be operated with either a definite time delay (**50Ns-1 PICKUP** and **50Ns-1 DELAY**) or with a user-defined Curve (**51Ns PICKUP** and **51NsTIME DIAL**). The characteristics of these current elements can be configured. Each of these elements may be directional or non-directional.

In case of capacitive voltage measurement, the current elements operate non-directional only since an exact angle measurement is not ensured when using the voltage V_0 .

The pickup of the definite time overcurrent protection can be stabilized by the configured dropout delay time (address 3121 **50Ns T DROP-OUT**).

Determination of Direction

When determining the sensitive ground fault direction it is not the current value that is crucial, but the part of the current which is perpendicular to a settable directional characteristic (axis of symmetry). As a prerequisite for determining the direction, the displacement voltage V_0 must be exceeded as well as a configurable current part influencing the direction (active or reactive component).

The following figure illustrates an example using a complex vector diagram in which the displacement voltage V_0 is the reference magnitude of the real axis. The active part $3I_{0real}$ of current $3I_0$ is calculated with reference to the displacement voltage V_0 and compared with setting value **RELEASE DIRECT.**. The example is therefore suitable for ground fault direction in resonant grounded systems where quantity $3I_0 \cdot \cos \varphi$ is relevant. The directional limit lines are perpendicular to axis $3I_{0real}$.

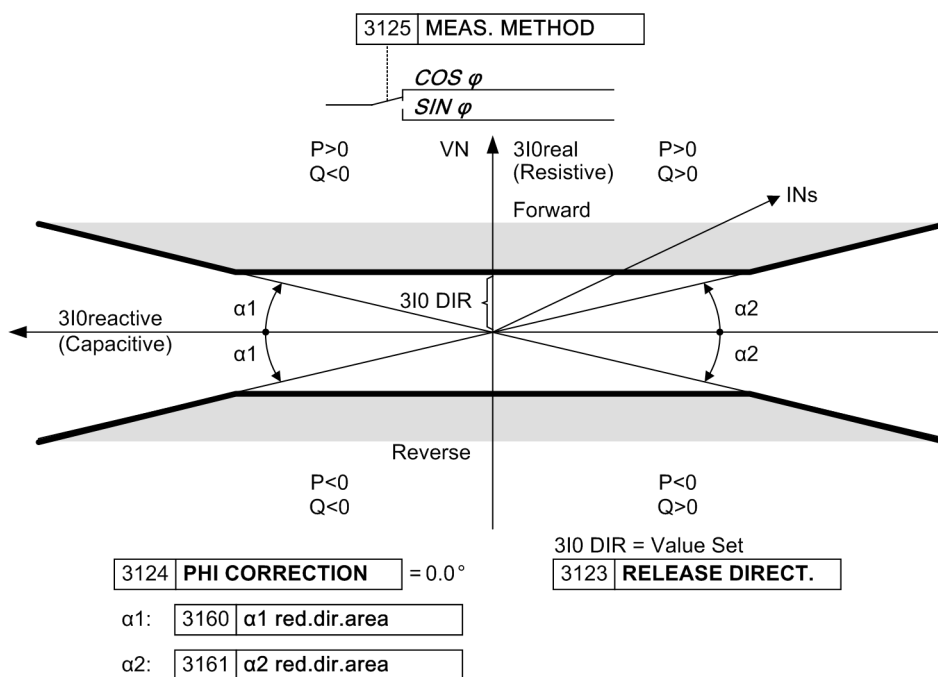

Figure 2-82 Directional characteristic for $\cos\varphi$ -measurement

The directional limit lines may be rotated by a correction angle (address **PHI CORRECTION**) up to $\pm 45^\circ$. Therefore, in grounded systems it is possible e.g. to increase sensitivity in the resistive-inductive range with a rotation of -45° , or in case of electric machines connected to the busbar of an ungrounded power system in the resistive-capacitive range with a rotation of $+45^\circ$ (see the following Figure). Furthermore the directional limit lines may be rotated by 90° to determine ground faults and their direction in isolated systems.

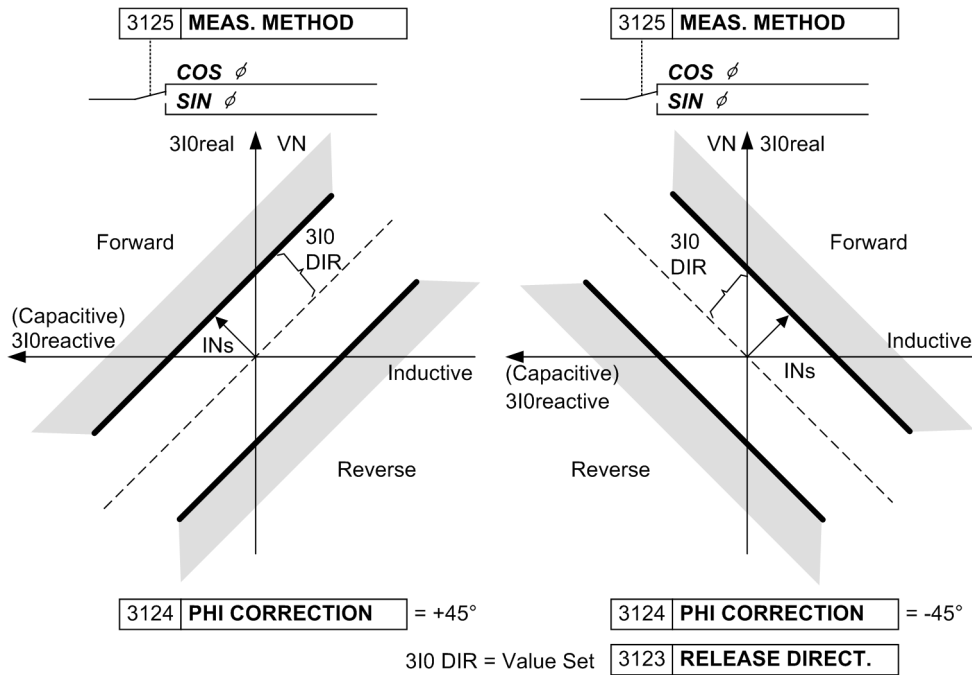

Figure 2-83 Directional characteristic for cos-φ-measurement

Fault direction is calculated with the zero sequence values from the ground current $3I_0$ and displacement voltage V_0 or $3 \cdot V_0$. With these quantities ground active power and ground reactive power is calculated.

The calculation algorithm used filters the measured values so that it is highly accurate and insensitive to higher harmonics (particularly the 3rd and 5th harmonics – which are often present in zero sequence currents). Direction determination relies on the sign of active and reactive power.

Since active and reactive components of the current - not the power - are relevant for pickup, current components are calculated from the power components. When determining the ground fault direction the active or reactive components of the ground current in reference to the displacement voltage as well as the direction of the active and reactive power are evaluated.

For measurements of $\sin \varphi$ (for ungrounded systems) the following applies

- Ground fault (forward direction), if $Q_0 < 0$ and $3I_{0\text{reactive}} > \text{setting value (RELEASE DIRECT.)}$,
- Ground fault (reverse direction), if $Q_0 > 0$ and $3I_{0\text{reactive}} > \text{setting value (RELEASE DIRECT.)}$.

For measurements $\cos \varphi$ (for resonant grounded systems) the following applies

- Ground fault (forward direction), if $P_0 > 0$ and $3I_{0\text{active}} > \text{setting value (RELEASE DIRECT.)}$,
- Ground fault (reverse direction), if $P_0 < 0$ and $3I_{0\text{active}} > \text{setting value (RELEASE DIRECT.)}$.

If **PHI CORRECTION** is unequal 0° , the angle of the directional limit lines is calculated by adding up active and reactive power components.

The forward and reverse zone can be reduced at its boundaries at address 3160 $\alpha 1$ **red.dir.area** and address 3161 $\alpha 2$ **red.dir.area** (see Figure 2-82).

Logic

The following figure illustrates the activation criteria of the sensitive ground fault protection. The operational mode of the ground fault detection can be set under address 3101.

If set to **ON**, tripping is possible and a fault log is generated.

If set to **Alarm Only**, tripping is not possible and only a ground fault log is generated.

The pickup of the displacement voltage element V_0 starts the ground fault recording. As the pickup of the V_0 Element drops out, fault recording is terminated (see logic diagrams 2-85 and 2-86).

The entire function can be blocked under the following conditions:

- A binary input is set,
- the Fuse Failure Monitor or the voltage transformer protection breaker pick up and parameter 3130 **PU CRITERIA** is set to **Vgnd AND INs**,
- the Fuse Failure Monitor or the voltage transformer protection breaker pick up and parameter 3130 **PU CRITERIA** is set to **Vgnd OR INs**, and both current elements are in directional operation mode.

Switching off or blocking means that measurement is deactivated. Therefore, time delays and pickup messages are reset.

All elements can be blocked individually via binary inputs. In this case pickup and, if possible, direction and grounded phase will still be reported, however, tripping does not take place since the time elements are blocked.

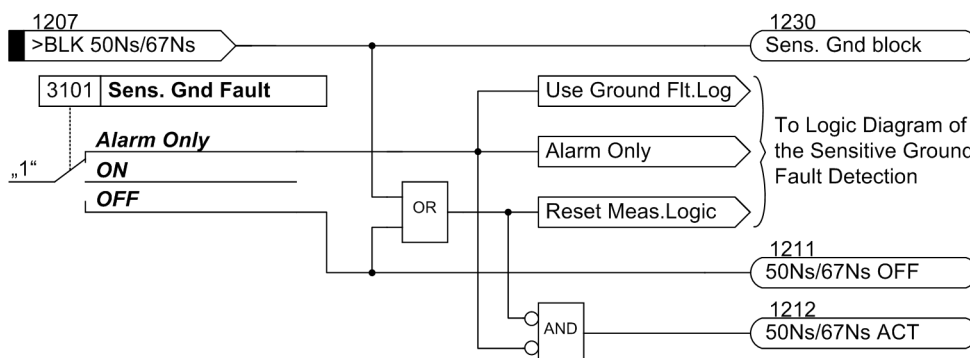

Figure 2-84 Activation of the sensitive ground-fault detection for $\cos\varphi$ / $-\sin\varphi$ measurement

Generation of a pickup message, for both current elements, is dependent on the direction selection for each Element and the setting of parameters 3130 **PU CRITERIA**. If the Element is set to **Non-Directional** and parameter **PU CRITERIA** = **Vgnd OR INs**, a pickup message is generated as soon as the current threshold is exceeded, irrespective of the status of the V_0 Element. If, however, the setting of parameter **PU CRITERIA** is **Vgnd AND INs**, the V_0 -Element must have picked up also for non-directional mode.

However, if a direction is programmed, the current element must be picked up and the direction determination results must be present to generate a message. Once again, a condition for valid direction determination is that the voltage Element V_0 be picked up.

Parameter **PU CRITERIA** specifies, whether a fault is generated by means of the AND-function or the OR-combination of displacement voltage and pickup of the ground current. The former may be advantageous if the pickup setting of displacement voltage element V_0 was chosen to be very low.

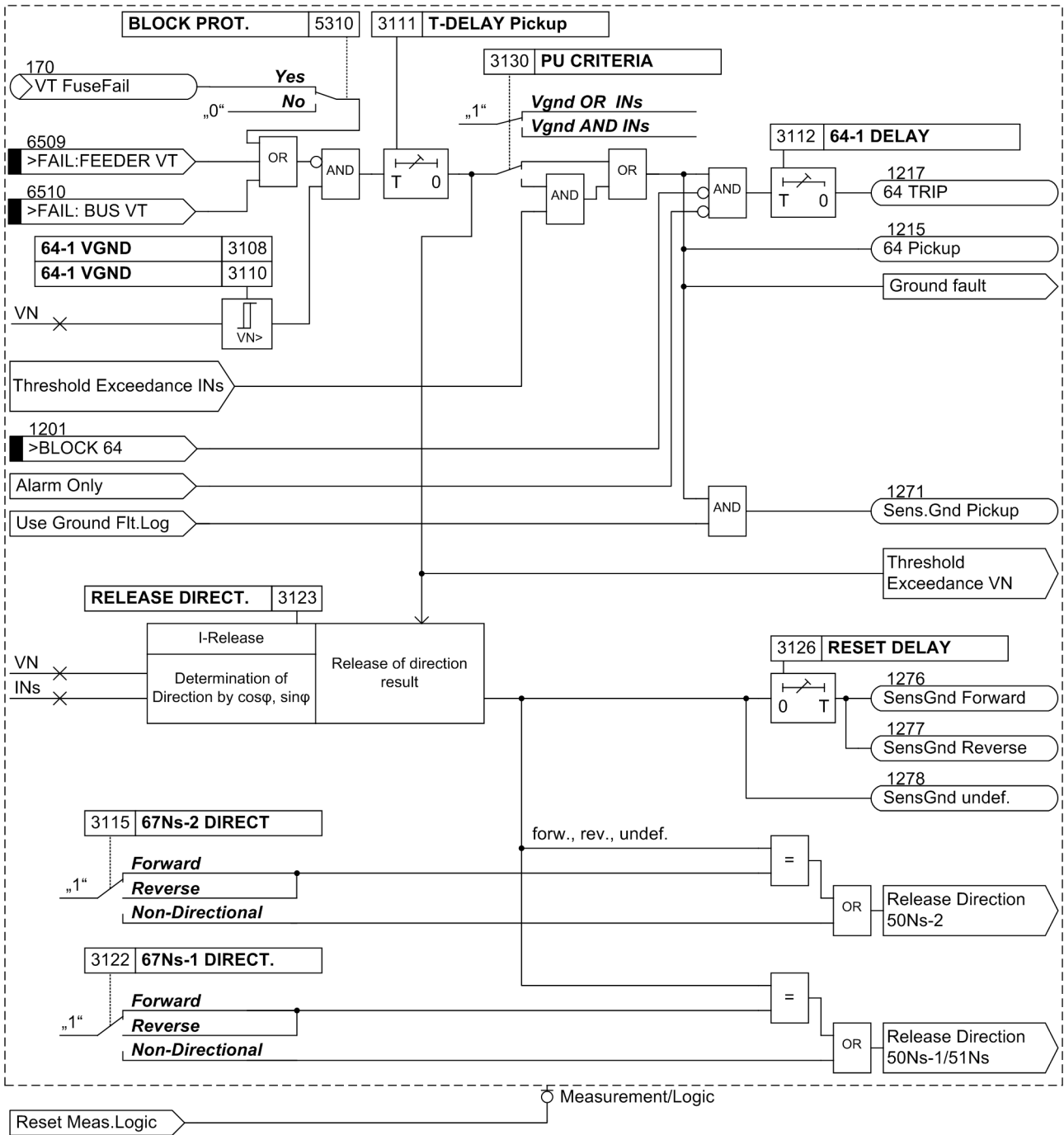

Figure 2-85 Logic diagram of the $V_{N>}$ element for $\cos-\varphi$ / $\sin-\varphi$ measurement

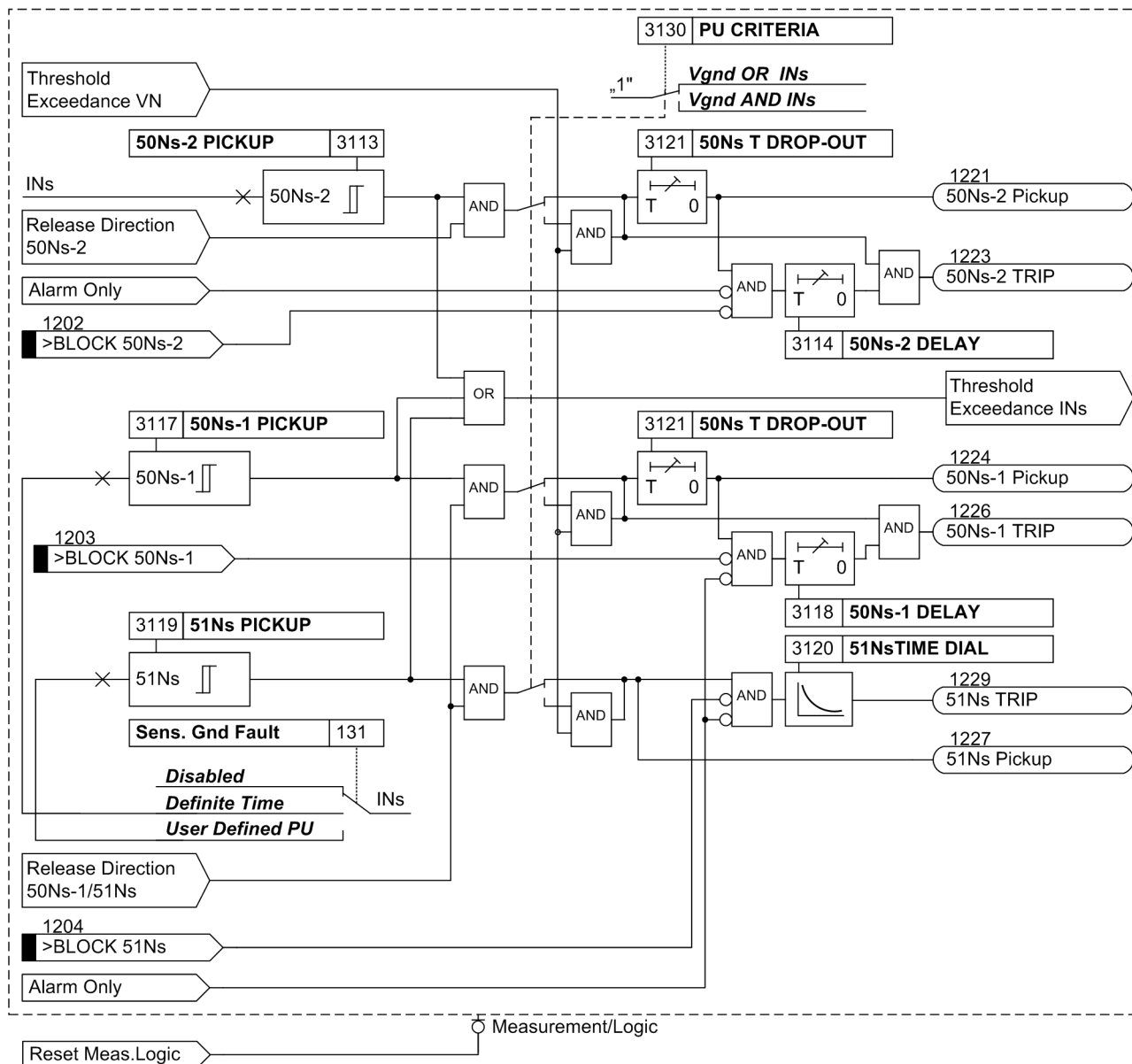

Figure 2-86 Logic diagram of the I_{Ns} elements during $\cos \varphi / \sin \varphi$ measurement

2.12.2 Ground Fault Detection for V0/I0-φ Measurement

Voltage Element

The voltage element relies on a pickup initiated by the displacement voltage V_0 or $3 \cdot V_0$. Additionally, the faulty phase is determined. The displacement voltage V_0 can be directly applied to the device, or the summation voltage $3 \cdot V_0$ can be calculated according to the connection type of the voltage transformer (see also Parameter 213 **VT Connect. 3ph** in Section 2.1.3). When setting **Van**, **Vbn**, **Vcn**, the calculation of the summation voltage $3 \cdot V_0$ is based on the three phase-to-Ground voltages. The three voltage inputs must therefore be connected to the voltage transformers in a grounded-ye configuration. When setting **Vab**, **Vbc**, **VGnd**, the three phase-to-Ground voltages of both connected phase-to-phase voltages and the connected displacement voltage are calculated. If the device is only provided with phase-to-phase voltages, it is not possible to calculate a displacement voltage from them. In this case, the direction cannot be determined.

If the displacement voltage is calculated, then:

$$3 \cdot V_0 = V_A + V_B + V_C$$

If the displacement voltage is directly applied to the device, then V_0 is the voltage at the device terminals. It is not affected by parameter **Vph** / **Vdelta** (address 206).

The voltage element is not available when using capacitive voltage measurement.

Pickup performed by the displacement voltage can be delayed (**64-1 DELAY**) for tripping.

It is important to note that the total trip-command time then consists of the displacement voltage measurement time (about 50 ms) plus the pickup delay time **64-1 DELAY**.

After the voltage element picks up due to detection of a displacement voltage, the grounded phase is identified, if possible. For this purpose, the individual phase-to-Ground voltages are measured or calculated, irrespective of the connection type of the voltage transformers. If the voltage magnitude for any given phase falls below the set threshold **VPH MIN**, that phase is detected as the grounded phase as long as the remaining phase-to-Ground voltages exceed the set threshold **VPH MAX**.

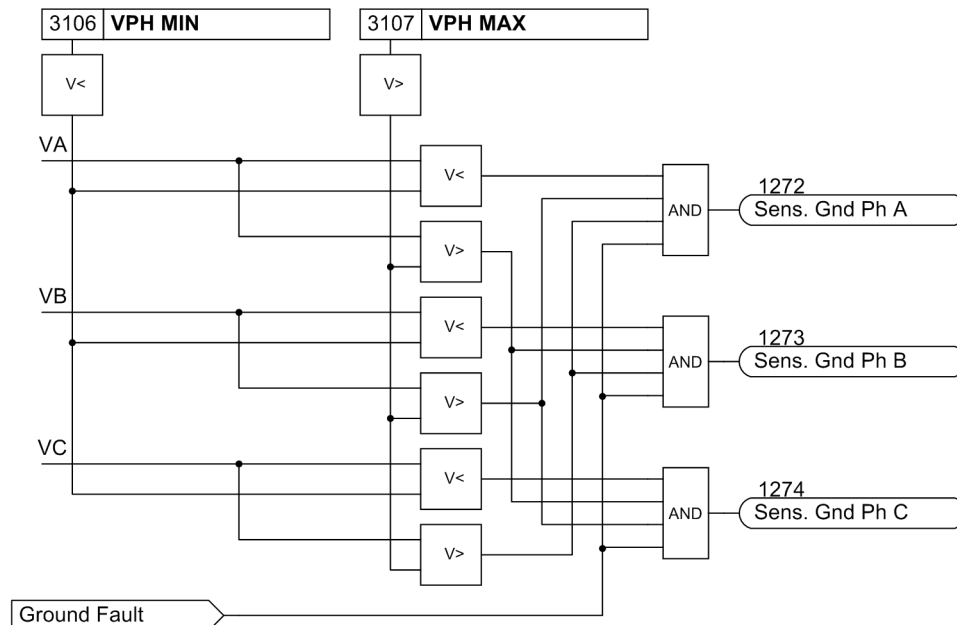

From Logic Diagram of the Sensitive Ground Fault Detection

Figure 2-87 Determination of Ground-faulted Phase

Current Elements

There are two current elements available. Both elements operate directionally, whereby the tripping zones can be set individually for each element (see margin heading „Tripping Area“).

In case of capacitive voltage measurement, the current elements operate non-directional only since an exact angle measurement is not ensured when using the voltage V_0 .

Both elements are provided with a definite time characteristic. Two current/time elements are used for ground fault protection. Analog to the time overcurrent protection function, the overcurrent element is named **50Ns-1 PICKUP** and **50Ns-1 DELAY** and the high-set element **50Ns-2 PICKUP** and **50Ns-2 DELAY**.

The pickup of the definite time overcurrent protection can be stabilized by the configured dropout delay time (address 3121 **50Ns T DROP-OUT**).

Tripping Range

The $U_0/I_0-\varphi$ characteristic is illustrated as a sector in the U_0/I_0 phasor diagram (see Figure 2-88). This sector corresponds to the tripping area. If the cursor of the ground current is in this sector, the function picks up.

The tripping area is defined via several parameters: Via the angle φ (parameter 3154 **50Ns-1 Phi** or 3151 **50Ns-2 Phi**), the center of the zone with reference to the displacement voltage V_0 is set. Via the angle $\Delta\varphi$ (parameter 3155 **50Ns-1 DeltaPhi** or 3152 **50Ns-2 DeltaPhi**), the zone is extended to both sides of the center.

The zone is further limited downwards by minimum values of the displacement voltage and ground current. These settable threshold values must be exceeded in order to be picked up.

Negative angle settings turn the tripping area in the „inductive“ direction, i.e. ground current inductive compared to ground voltage.

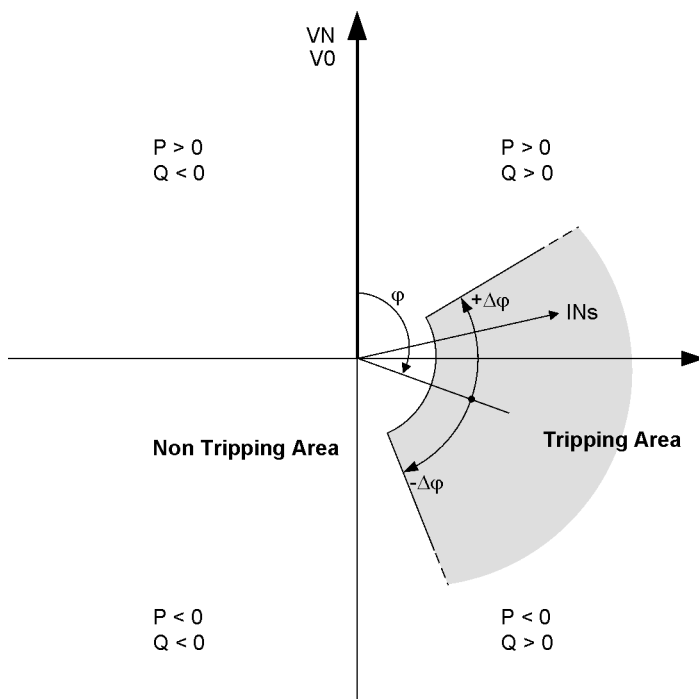

Figure 2-88 Tripping range of $V_0/I_0-\varphi$ characteristic

Logic

The following figure illustrates the activation criteria of the sensitive ground fault protection. The operational mode of the ground fault detection can be set under address 3101.

If set to **ON**, tripping is possible and a fault log is generated.

If set to **ON with GF log**, tripping is possible, a fault log and a ground fault log are generated.

If set to **Alarm Only**, tripping is not possible and only a ground fault log is generated.

The pickup of the displacement voltage V_0 or pickup of the 50Ns-2 element or pickup of the 50Ns-1 or 51Ns element start the ground fault recording. As the pickup of the Element drops out, fault recording is terminated (see logic diagrams 2-90 and 2-91).

The entire function can be blocked under the following conditions:

- A binary input is set,
- the Fuse Failure Monitor or the voltage transformer protection breaker pick up.

Switching off or blocking means that measurement is deactivated. Therefore, time delays and pickup messages are reset.

All elements can be blocked individually via binary inputs. In this case pickup and, if possible, direction and grounded phase will still be reported, however, tripping does not take place since the time elements are blocked.

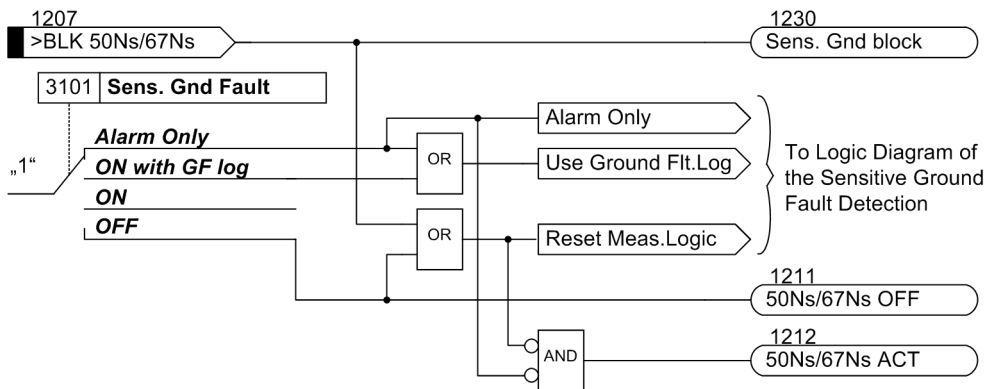

Figure 2-89 Activation of the sensitive ground fault detection for $V_0/I_0-\varphi$ measurement

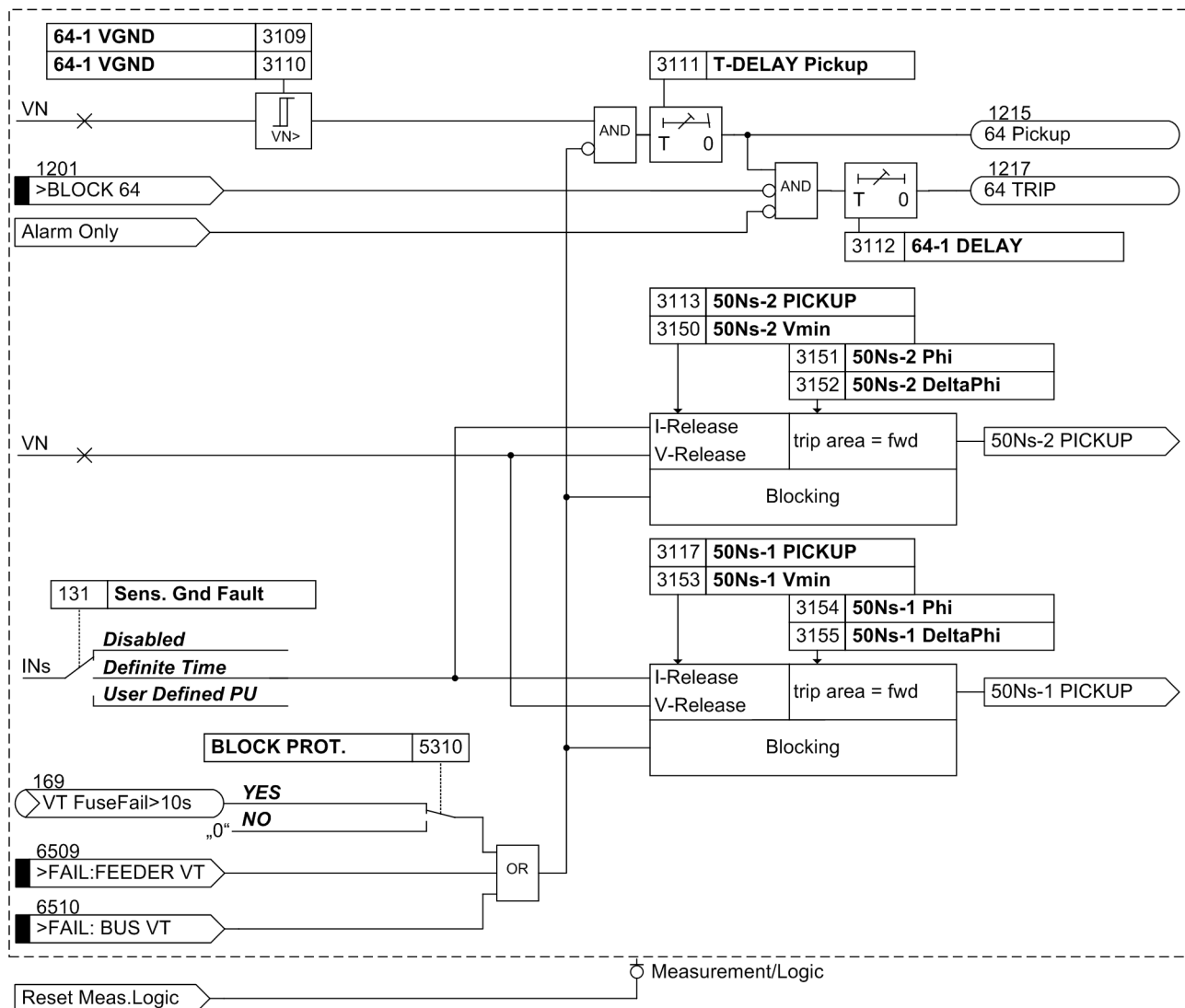

Figure 2-90 Logic diagram during V_0/I_0 ϕ measurement, part 1

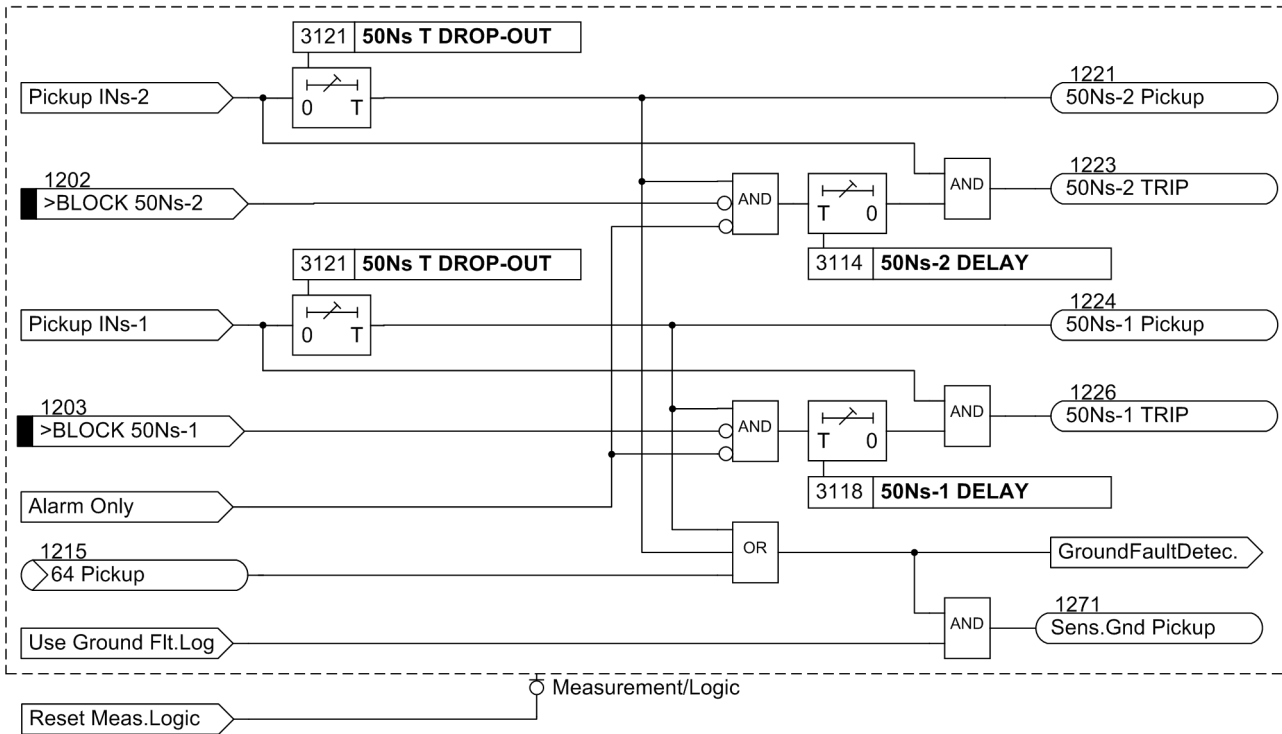

Figure 2-91 Logic diagram for U0-/I0 -φ measurement, part 2

2.12.3 Ground Fault Location

Application Example

Directional determination may often be used to locate ground faults. In radial systems, locating the ground fault is relatively simple. Since all feeders from a common bus (Figure 2-92) deliver a capacitive charging current, nearly the total ground fault current of the system is available at the measuring point of the faulty line in the ungrounded system. In the resonant grounded system it is the residual wattmetric current of the Petersen coil that flows via the measuring point. Therefore, on the faulty cables a clear "forward" decision is made whereas in other feeders either "reverse" direction is sent back or no measurement is carried out in case ground current is too low. Definitely the faulty line can be determined clearly.

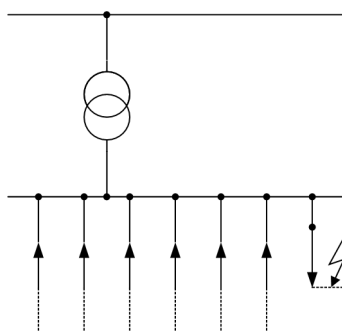

Figure 2-92 Location of ground faults in a radial network

In meshed or looped systems, the measuring points of the faulty line also receive the maximum ground fault current (residual current). Only in this line, "forward" direction is signaled at both ends (Figure 2-93). The rest of the direction indications in the system may also be useful for ground fault detection. However, some indications may not be given when the ground current is too low.

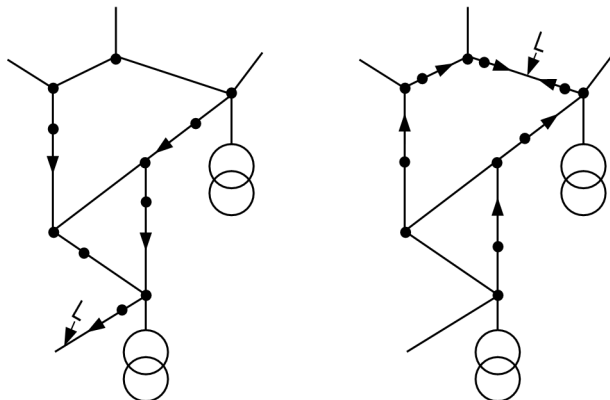

Figure 2-93 Determination of the ground fault location based on directional indicators in the meshed system

2.12.4 Setting Notes

General Settings

During configuration of the protection function (Section 2.1.1, under address 131 **Sens. Gnd Fault** it was determined with which parameters the ground fault detection is functioning. If address **Sens. Gnd Fault** = **Definite Time** is selected, then the definite-time parameters are available. If **Sens. Gnd Fault** = **User Defined PU** is selected, a user-specified Curve can be used for the overcurrent elements 50Ns-1 or 51Ns. The superimposed high-current element 50Ns-2 is available in all these cases. If this function is not required, then **Disabled** is set. The user characteristics are only available, if the standard measurement procedure **cos φ / sin φ** has been set at address 130.

The characteristic for determining the direction is set at address 130 **S.Gnd.F.Dir.Ch.** It is optional to select either the standard measurement method **cos φ / sin φ** or the **VO/IO φ mea.** with one sector characteristic.

At address 3101 **Sens. Gnd Fault**, the function **ON** or **OFF** can be set to either **ON with GF log** or **Alarm Only**. If settings **ON** and **ON with GF log** are applied, tripping is also possible, otherwise a fault log is created. A ground fault log is created for **ON with GF log** and **Alarm Only**. Setting **ON with GF log** is only available if characteristic **VO/IO φ mea.** has been selected at address 130 **S.Gnd.F.Dir.Ch.**

The parameters 3111 **T-DELAY Pickup** and 3130 **PU CRITERIA** are only visible if the standard measurement method **cos φ / sin φ** has been selected when setting the direction characteristic. The ground fault is detected and reported when the displacement voltage was sustained a certain time **T-DELAY Pickup**). Address 3130 **PU CRITERIA** specifies whether ground fault detection is enabled only for pickups of V_N and I_{NS} (**Vgnd AND INs**) or as soon as one of the two has picked up (**Vgnd OR INs**).

The pickup can be stabilized for ground fault protection with definite time curve by a settable dropout time delay (address 3121 **50Ns T DROP-OUT**). This facility is used in power systems with intermittent faults. Used together with electro-mechanical relays, it allows different dropout responses to be adjusted and time grading of digital and electro-magnetic relays to be implemented. The setting depends on the dropout time delay of the electro-magnetic relay. If no coordination is required, the preset value (zero = no dropout time delay) remains.

**Note**

Please note that under address 213 **VT Connect. 3ph** the connection type of the voltage transformer **Van, Vbn, Vcn** or **Vab, Vbc, VGnd** must be set. Additionally, adjustment factor **Vph / Vdelta** for the displacement voltage must be set correctly under address 206. Depending on the type of connection of the current transformer, the primary and secondary rated current in the ground path must be set under address 217 and 218, and, if required, the primary and secondary rated current of the second ground current transformer must be set under address 238 and 239.

Overcurrent Elements Definite Time/Inverse Time

A two-element current/time Curve can be set at addresses 3113 to 3120. These elements operate with the amounts of the ground current. They are therefore only useful where the magnitude of the ground current and maybe its direction can be used to specify the ground fault. This may be the case for grounded systems (solid or low-resistance) or on electrical machines connected to the busbar of an ungrounded power system, when in case of a network ground fault the machine supplies only a negligible ground fault current across the measurement location, which must be situated between the machine terminals and the network, whereas in case of a machine ground fault the total ground fault current produced by the total network is available.

User-defined Curve (Inverse Time)

User-defined characteristics are only used for the standard measurement method $\cos \varphi / \sin \varphi$ (address 130 **S.Gnd.F.Dir.Ch**). During configuration of a user-defined Curve, it should be noted that there is a safety factor of approx. 1.1 between pickup and setting value - as is standard for inverse curves. This means that pickup will only be initiated when current of 1.1 times the setting value flows.

The value pairs (current and time) are entered as multiples of the values at addresses 3119 **51Ns PICKUP** and 3120 **51Ns TIME DIAL**. Therefore, it is recommended that these addresses are initially set to 1.00 for simplicity reasons. Once the curve has been entered, the settings at addresses 3119 and/or 3120 can be modified if necessary.

The default setting of current values is ∞ . They are, therefore, not enabled — and no pickup or tripping of these protective functions will occur.

Up to 20 value pairs (current and time) may be entered at address 3131 **M.of PU TD**. The device then approximates the Curve, using linear interpolation.

The following must be observed:

- The value pairs should be entered in increasing sequence. If desired, fewer than 20 pairs can be entered. In most cases, about 10 pairs is sufficient to define the Curve accurately. A value pair which will not be used has to be made invalid by entering " ∞ " for the threshold! The user must ensure that the value pairs produce a clear and constant Curve

The current values entered should be those from Table 2-13, along with the matching times. Deviating values I/I_p are rounded. This, however, will not be indicated.

Current below the current value of the smallest curve point will not lead to an extension of the tripping time. The pickup curve (see Figure 2-94) continues, from the smallest current point parallel to the current axis.

Current flows greater than the highest current value entered will not result in a reduced tripping time. The pickup curve (see Figure 2-94) continues, from the largest current point parallel to the current axis.

Table 2-13 Preferential Values of Standardized Currents for User-specific Tripping Curves

MofPU = 1 to 1.94		MofPU = 2 to 4.75		MofPU = 5 to 7.75		MofPU p = 8 to 20	
1.00	1.50	2.00	3.50	5.00	6.50	8.00	15.00
1.06	1.56	2.25	3.75	5.25	6.75	9.00	16.00
1.13	1.63	2.50	4.00	5.50	7.00	10.00	17.00
1.19	1.69	2.75	4.25	5.75	7.25	11.00	18.00
1.25	1.75	3.00	4.50	6.00	7.50	12.00	19.00
1.31	1.81	3.25	4.75	6.25	7.75	13.00	20.00
1.38	1.88					14.00	
1.44	1.94						

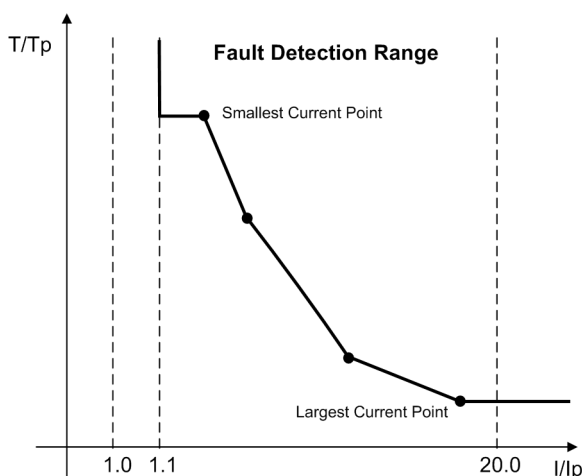

Figure 2-94 Use of a user-defined Curve

Determination of Ground-faulted Phase

The phase connected to ground may be identified in an ungrounded or resonant grounded system, if the device is supplied by three voltage transformers connected in a grounded-wye configuration or the phase-Ground voltages are calculated. The phase in which the voltage lies below setting **VPH MIN** (address 3106) is identified as the faulty phase as long as the other two phase voltages simultaneously exceed setting **VPH MAX** (address 3107). The setting **VPH MIN** must be set to less than the minimum expected operational phase-to-Ground voltage. A typical setting for this address would be 40 V. Setting **VPH MAX** must be greater than the maximum expected operational phase-to-Ground voltage, but less than the minimum expected operational phase-to-phase voltage. For $V_{Nom} = 100$ V, approximately 75 V is a typical setting. These settings have no significance in a grounded system.

Displacement Voltage Element V_0

The displacement voltage **64-1 VGND** (address 3109) or **64-1 VGND** (address 3110) is the pickup of the ground fault detection and a release condition for the direction determination (when setting the direction characteristic to $\cos \varphi / \sin \varphi$). If the direction characteristic is set to $VO / IO \varphi mea.$, the displacement voltage element is entirely independent of the current elements. Depending on the configuration at address 213 **VT Connect. 3ph**, only the applicable limit value address 3109 **64-1 VGND** or 3110 **64-1 VGND** is accessible.

That is, if two phase-to-phase voltages and the displacement voltage V_0 are supplied to the device, the measured displacement voltage is used directly for ground fault recognition. The threshold for V_0 is set at address 3109 **64-1 VGND**, where a more sensitive setting can be made than with a calculated displacement voltage. Please note that with displaced voltage V_0 -voltage, the factor (in normal case = 1.73; see also Section 2.1.3.2)

specified with parameter 206 **Vph / Vdelta** is used. For the display of the parameters 3109 **64-1 VGND** in primary values, the following conversion formula applies:

$$V_{N \text{ prim}} = V_{ph/Vdelta} \cdot \frac{V_{nom \text{ primary}}}{V_{nom \text{ secondary}}} \cdot V_{N \text{ sec}}$$

If three phase-to-Ground voltages are connected to the device, the displacement voltage $3 \cdot V_0$ is calculated from the momentary values of phase-to-Ground voltages, and address 3110 is where the threshold is to be set. For the display of parameter 3110 in primary values, the following applies:

$$3V_{0 \text{ prim}} = \frac{V_{nom \text{ Primary}}}{V_{nom \text{ Secondary}}} \cdot 3V_{0 \text{ sec}}$$

If the secondary values of (for example) parameters 3109 and 3110 are set equally, then their primary values differ by adjustment value **Vph / Vdelta**.

Example:

Parameter 202	Vnom PRIMARY	= 12 kV
Parameter 203	Vnom SECONDARY	= 100 V
Parameter 206	Vph / Vdelta	= 1.73
Parameter 213	VT Connect. 3ph	= Vab, Vbc, VGnd
Parameter 3109	64-1 VGND	= 40 V

The following applies when switching to primary values:

$$3109 \quad VGND \text{ (measured)} = 40 \text{ V} \cdot 1.73 \cdot \frac{12 \text{ kV}}{100 \text{ V}} = 8.3 \text{ kV}$$

With the following configuration

Parameter 213	VT Connect. 3ph	= Van, Vbn, Vcn
Parameter 3110	64-1 VGND	= 40 V

the following applies when switching to primary values:

$$3110 \quad VGND \text{ calculated} = 40 \text{ V} \cdot \frac{12 \text{ kV}}{100 \text{ V}} = 4.8 \text{ kV}$$

With regard to a ground fault in a ungrounded or resonant-grounded system, nearly the entire displacement voltage appears at the device terminals, therefore the pickup setting is not critical, and typically lies between 30 V and 60 V (for **64-1 VGND** with a standard V0-connection) or 50 V and 100 V (for **64-1 VGND**). Large fault resistances may require higher sensitivity (i.e. a lower pickup setting).

With regard to a grounded system, a more sensitive (lower) pickup value may be set, but it must be above the maximum anticipated displacement voltage during normal (unbalanced) system operation.

Pickup of just the voltage element may initiate time delayed tripping assumed that ground fault detection is configured to perform tripping (address 3101 **Sens. Gnd Fault = ON or ON with GF log**) and moreover address 3130 **PU CRITERIA** is configured **Vgnd OR INs**. The tripping delay is then set at address 3112 **64-1 DELAY**. It is important to note that the total tripping time consists of the displacement voltage measurement time (about 50 ms) plus the pickup time delay (address 3111 **T-DELAY Pickup**) plus the tripping time delay (address 3112 **64-1 DELAY**).

Direction Determination for $\cos\varphi$ / $\sin\varphi$

Addresses 3115 to 3126 are important for direction determination.

Address 3115 **67Ns-2 DIRECT** determines the direction of the definite high-set current element 50Ns-2 and can be set to either **Forward** or **Reverse** or **Non-Directional**, i.e. to both directions. The direction of the current element 50Ns-1 or 51Ns can be set to **Forward** or **Reverse** or **Non-Directional**, i.e. to both directions, at address 3122 **67Ns-1 DIRECT**.

The elements operate non-directional for capacitive voltage measurement and for voltage connection types where measurement or calculation of V_N or $3V_0$ is not possible. Section 2.1.3.2 gives information on this topic.

Current value **RELEASE DIRECT**. (address 3123) is the release threshold for directional determination. It is based on the current components which are perpendicular to the directional limit lines. The position of the directional limit lines themselves are based on the settings entered at addresses 3124 and 3125.

The following applies to the determination of direction during ground faults: The pickup current 3I0 DIR. (=RELEASE DIRECT. address 3123) must be set as high as possible to avoid false pickup of the device provoked by asymmetrical currents in the system and by current transformers (especially in the Holmgreen-connection).

If direction determination is used in conjunction with one of the current elements discussed above (**50Ns-1 PICKUP**, addresses 3117 ff, or **51Ns PICKUP**, addresses 3119 ff), it is sensible to select a value for address **RELEASE DIRECT**. that is lower than or equal to the above pickup value.

A corresponding message (reverse, forward, or undefined) is issued upon direction determination. To avoid chatter for this message resulting from extremely varying ground connection currents, a dropout delay **RESET DELAY**, entered at address 3126, is initiated when directional determination drops out, and the message is held for this period of time.

When address 3124 **PHI CORRECTION** is set to 0.0° , in address 3125 the following signifies

- **MEAS. METHOD = COS φ**
the resistive component of the ground current with respect to the displacement voltage is most relevant for the current value **RELEASE DIRECT**. (3I0 DIR.),
- **MEAS. METHOD = SIN φ**
the reactive (capacitive) component of the ground current with respect to the displacement voltage is most relevant for the current value **RELEASE DIRECT**. (3I0 DIR.) (Figure 2-95).

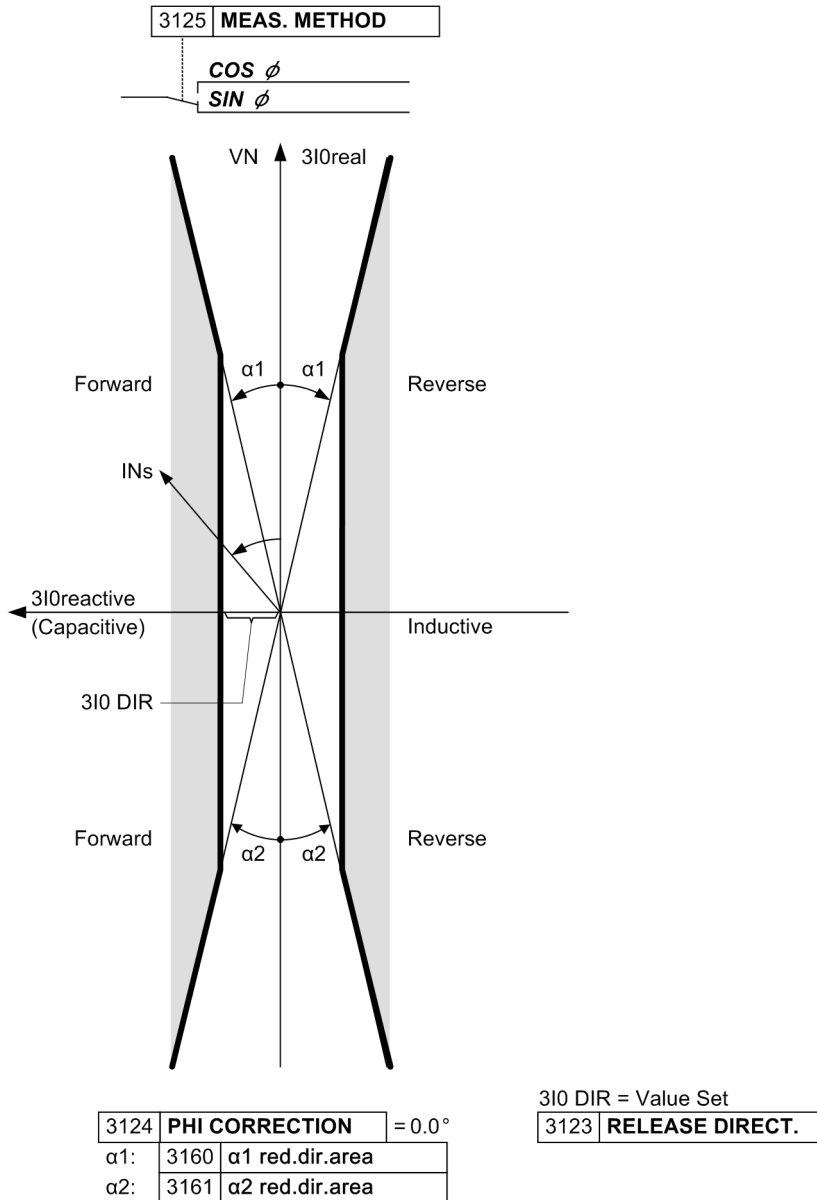

Figure 2-95 Directional characteristic for sin-φ-measurement

- In address 3124 **PHI CORRECTION** the directional line, in this respect, may be rotated within the range $\pm 45^\circ$. Figure 2-83 "Directional characteristic for cos-φ-measurement" in the functional description of the sensitive ground fault detection gives an example regarding this topic.

The forward and reverse zone can be reduced at its boundaries at address 3160 **α_1 red.dir.area** and address 3161 **α_2 red.dir.area** (see Figure 2-95). Siemens recommends using the default setting of 2° (this corresponds to the behavior of versions without this setting option). In a grounded system in feeders with very high capacitive current, it can be reasonable to set a slightly larger angle α_1 to prevent erroneous pickup due to transformer and algorithm tolerances.

Direction Determination for V0/I0 φ Measurement

With the minimum voltage **50Ns-2 Vmin**, address 3150 and the level of the pickup current **50Ns-2 PICKUP**, address 3113, the lower limit of the circuit segment of element 50Ns-2 is set. The thresholds of the tripping range in respect of the displacement voltage is set by means of the matching phase angle **50Ns-2 Phi**, address 3151 and angle **50Ns-2 DeltaPhi**, address 3152. The trip delay time is set under address 3114 **50Ns-2 DELAY**. The actual settings are based on the respective application.

The minimum voltage **50Ns-1 Vmin** of the high-current element 50Ns-1 is set under address 3153, the pickup current **50Ns-1 PICKUP** under 3117. The respective phase angle **50Ns-1 Phi** is set under address 3154, the angle **50Ns-1 DeltaPhi** is entered under address 3155. The angle should be set to 180° so that the element functions non-directionally. The trip delay time is set under address 3118 **50Ns-1 DELAY**.

Positive angle settings (address 3151 and 3154) turn the tripping area in the „capacitive“ direction, i.e. ground current capacitive compared to ground voltage.

Negative angle settings turn the tripping area in the „inductive“ direction, i.e. ground current inductive compared to ground voltage.

Angular Error Compensation (I Transformer)

The high reactive component in a resonant grounded system and the inevitable air gap of the toroidal current transformer often require the angle error of the toroidal current transformer to be compensated. In addresses 3102 to 3105 the maximum angle error **CT Err. F1** and the associated secondary current **CT Err. I1** as well as another operating point **CT Err. F2/CT Err. I2** are set for the actually connected burden. The device thus approximates the transformation characteristic of the transformer with considerable accuracy. In ungrounded or grounded systems angle compensation is not required.

Ungrounded System

In an ungrounded system with a ground fault on a cable, capacitive ground currents of the galvanically connected system flow via the measuring point, except for the ground current generated in the grounded cable, since the current last-mentioned will flow directly to the fault location (i.e. not via the measuring point). A setting equal to about half the ground current is to be selected. The measurement method should be **SIN φ** , since capacitive ground current is most relevant here.

Resonant-Grounded System

In resonant-grounded systems, directional determination on the occurrence of a ground fault is more difficult since the low residual wattmetric current for measurement is usually dwarfed by a reactive current (be it capacitive or inductive) which is much higher. Therefore, depending on the system configuration and the position of the arc-compensating coil, the total ground current supplied to the device may vary considerably in its values with regard to magnitude and phase angle. The relay, however, must evaluate only the active component of the ground fault current, that is, $I_{Ns} \cos \varphi$. This demands extremely high accuracy, particularly with regard to phase angle measurement of all instrument transformers. Furthermore, the device must not be set to operate too sensitive. When applying this function in resonant-grounded systems, a reliable direction determination can only be achieved when toroidal current transformers are connected. Here the following rule of thumb applies: Set pickup values to about half of the expected measured current, thereby considering only the residual wattmetric current. Residual wattmetric current predominantly derives from losses of the Petersen coil. Here, the **COS φ** measurement method is used since the resistive residual wattmetric current is most relevant.

Grounded System

In grounded systems, a value is set below the minimum anticipated ground fault current. It is important to note that 3I0 DIR (current value **RELEASE DIRECT.**) only detects the current components that are perpendicular to the directional limit lines defined at addresses 3124 and 3125. **COS φ** is the method of measurement used, and the correction angle is set to -45°, since the ground fault current is typically resistive-inductive (right section

of Figure 2-83 "Directional curve for $\cos\varphi$ -measurement" in the functional description of the sensitive ground fault detection).

Electrical Machines

One may set the value **COS** φ for the measurement method and use a correction angle of +45° for electrical motors supplied from a busbar in an ungrounded system, since the ground current is often composed of an overlap of the capacitive ground current from the system and the resistive current of the load resistance (left part of Figure "Directional characteristic for $\cos\varphi$ -measurement" in the functional description of the sensitive ground fault detection).

Information on the Configuration of the Current Threshold

With devices with sensitive ground fault input, generally settings may be entered in primary values with consideration given to the ratio of the applicable current transformer. However, problems related to the resolution of the pickup currents can occur when very small settings and small nominal primary currents are involved. The user is therefore encouraged to enter settings for the sensitive ground fault detection in secondary values.

2.12.5 Settings

Addresses which have an appended "A" can only be changed with DIGSI, under "Display Additional Settings".

The table indicates region-specific default settings. Column C (configuration) indicates the corresponding secondary nominal current of the current transformer.

Addr.	Parameter	C	Setting Options	Default Setting	Comments
3101	Sens. Gnd Fault		OFF ON ON with GF log Alarm Only	OFF	(Sensitive) Ground Fault
3102	CT Err. I1	1A	0.001 .. 1.600 A	0.050 A	Current I1 for CT Angle Error
		5A	0.005 .. 8.000 A	0.250 A	
3102	CT Err. I1	1A	0.05 .. 35.00 A	1.00 A	Current I1 for CT Angle Error
		5A	0.25 .. 175.00 A	5.00 A	
3103	CT Err. F1		0.0 .. 5.0 °	0.0 °	CT Angle Error at I1
3104	CT Err. I2	1A	0.001 .. 1.600 A	1.000 A	Current I2 for CT Angle Error
		5A	0.005 .. 8.000 A	5.000 A	
3104	CT Err. I2	1A	0.05 .. 35.00 A	10.00 A	Current I2 for CT Angle Error
		5A	0.25 .. 175.00 A	50.00 A	
3105	CT Err. F2		0.0 .. 5.0 °	0.0 °	CT Angle Error at I2
3106	VPH MIN		10 .. 100 V	40 V	L-Gnd Voltage of Faulted Phase Vph Min
3107	VPH MAX		10 .. 100 V	75 V	L-Gnd Voltage of Unfaulted Phase Vph Max
3109	64-1 VGND		1.8 .. 200.0 V; ∞	40.0 V	64-1 Ground Displacement Voltage
3110	64-1 VGND		10.0 .. 225.0 V; ∞	70.0 V	64-1 Ground Displacement Voltage

Addr.	Parameter	C	Setting Options	Default Setting	Comments
3111	T-DELAY Pickup		0.04 .. 320.00 sec; ∞	1.00 sec	Time-DELAY Pickup
3112	64-1 DELAY		0.10 .. 40000.00 sec; ∞	10.00 sec	64-1 Time Delay
3113	50Ns-2 PICKUP	1A	0.001 .. 1.600 A	0.300 A	50Ns-2 Pickup
		5A	0.005 .. 8.000 A	1.500 A	
3113	50Ns-2 PICKUP	1A	0.05 .. 35.00 A	10.00 A	50Ns-2 Pickup
		5A	0.25 .. 175.00 A	50.00 A	
3114	50Ns-2 DELAY		0.00 .. 320.00 sec; ∞	1.00 sec	50Ns-2 Time Delay
3115	67Ns-2 DIRECT		Forward Reverse Non-Directional	Forward	67Ns-2 Direction
3117	50Ns-1 PICKUP	1A	0.001 .. 1.600 A	0.100 A	50Ns-1 Pickup
		5A	0.005 .. 8.000 A	0.500 A	
3117	50Ns-1 PICKUP	1A	0.05 .. 35.00 A	2.00 A	50Ns-1 Pickup
		5A	0.25 .. 175.00 A	10.00 A	
3118	50Ns-1 DELAY		0.00 .. 320.00 sec; ∞	2.00 sec	50Ns-1 Time delay
3119	51Ns PICKUP	1A	0.001 .. 1.400 A	0.100 A	51Ns Pickup
		5A	0.005 .. 7.000 A	0.500 A	
3119	51Ns PICKUP	1A	0.05 .. 4.00 A	1.00 A	51Ns Pickup
		5A	0.25 .. 20.00 A	5.00 A	
3120	51NsTIME DIAL		0.10 .. 4.00 sec; ∞	1.00 sec	51Ns Time Dial
3121A	50Ns T DROP-OUT		0.00 .. 60.00 sec	0.00 sec	50Ns Drop-Out Time Delay
3122	67Ns-1 DIRECT.		Forward Reverse Non-Directional	Forward	67Ns-1 Direction
3123	RELEASE DIRECT.	1A	0.001 .. 1.200 A	0.010 A	Release directional element
		5A	0.005 .. 6.000 A	0.050 A	
3123	RELEASE DIRECT.	1A	0.05 .. 30.00 A	0.50 A	Release directional element
		5A	0.25 .. 150.00 A	2.50 A	
3124	PHI CORRECTION		-45.0 .. 45.0 °	0.0 °	Correction Angle for Dir. Determination
3125	MEAS. METHOD		COS φ SIN φ	COS φ	Measurement method for Direction
3126	RESET DELAY		0 .. 60 sec	1 sec	Reset Delay
3130	PU CRITERIA		Vgnd OR INs Vgnd AND INs	Vgnd OR INs	Sensitive Ground Fault PICKUP criteria
3131	M.of PU TD		1.00 .. 20.00 MofPU; ∞ 0.01 .. 999.00 TD		Multiples of PU Time-Dial
3150	50Ns-2 Vmin		0.4 .. 50.0 V	2.0 V	50Ns-2 minimum voltage
3150	50Ns-2 Vmin		10.0 .. 90.0 V	10.0 V	50Ns-2 minimum voltage
3151	50Ns-2 Phi		-180.0 .. 180.0 °	-90.0 °	50Ns-2 angle phi

Addr.	Parameter	C	Setting Options	Default Setting	Comments
3152	50Ns-2 DeltaPhi		0.0 .. 180.0 °	30.0 °	50Ns-2 angle delta phi
3153	50Ns-1 Vmin		0.4 .. 50.0 V	6.0 V	50Ns-1 minimum voltage
3153	50Ns-1 Vmin		10.0 .. 90.0 V	15.0 V	50Ns-1 minimum voltage
3154	50Ns-1 Phi		-180.0 .. 180.0 °	-160.0 °	50Ns-1 angle phi
3155	50Ns-1 DeltaPhi		0.0 .. 180.0 °	100.0 °	50Ns-1 angle delta phi
3160	α 1 red.dir.area		1 .. 15 °	2 °	Alpha1 (reduction directional area)
3161	α 2 red.dir.area		1 .. 15 °	2 °	Alpha2 (reduction directional area)

2.12.6 Information List

No.	Information	Type of Information	Comments
1201	>BLOCK 64	SP	>BLOCK 64
1202	>BLOCK 50Ns-2	SP	>BLOCK 50Ns-2
1203	>BLOCK 50Ns-1	SP	>BLOCK 50Ns-1
1204	>BLOCK 51Ns	SP	>BLOCK 51Ns
1207	>BLK 50Ns/67Ns	SP	>BLOCK 50Ns/67Ns
1211	50Ns/67Ns OFF	OUT	50Ns/67Ns is OFF
1212	50Ns/67Ns ACT	OUT	50Ns/67Ns is ACTIVE
1215	64 Pickup	OUT	64 displacement voltage pick up
1217	64 TRIP	OUT	64 displacement voltage element TRIP
1221	50Ns-2 Pickup	OUT	50Ns-2 Pickup
1223	50Ns-2 TRIP	OUT	50Ns-2 TRIP
1224	50Ns-1 Pickup	OUT	50Ns-1 Pickup
1226	50Ns-1 TRIP	OUT	50Ns-1 TRIP
1227	51Ns Pickup	OUT	51Ns picked up
1229	51Ns TRIP	OUT	51Ns TRIP
1230	Sens. Gnd block	OUT	Sensitive ground fault detection BLOCKED
1264	IEEa =	VI	Corr. Resistive Earth current
1265	IEEr =	VI	Corr. Reactive Earth current
1266	IEE =	VI	Earth current, absolute Value
1267	VGND, 3Vo	VI	Displacement Voltage VGND, 3Vo
1271	Sens.Gnd Pickup	OUT	Sensitive Ground fault pick up
1272	Sens. Gnd Ph A	OUT	Sensitive Ground fault picked up in Ph A
1273	Sens. Gnd Ph B	OUT	Sensitive Ground fault picked up in Ph B
1274	Sens. Gnd Ph C	OUT	Sensitive Ground fault picked up in Ph C
1276	SensGnd Forward	OUT	Sensitive Gnd fault in forward direction
1277	SensGnd Reverse	OUT	Sensitive Gnd fault in reverse direction
1278	SensGnd undef.	OUT	Sensitive Gnd fault direction undefined
16029	51Ns BLK PaErr	OUT	Sens.gnd.flt. 51Ns BLOCKED Setting Error
16030	φ (3Vo,INs) =	VI	Angle between 3Vo and INsens.

2.13 Intermittent Ground Fault Protection

A typical characteristic of intermittent ground faults is that they often disappear automatically to strike again after some time. They can last between a few milliseconds and several seconds. This is why such faults are not detected at all or not selectively by the ordinary time overcurrent protection. If pulse durations are extremely short, not all protection devices in a short-circuit path may pick up; selective tripping is thus not ensured.

Due to the time delay of the overcurrent protection function such faults are too short to initiate shutdown of the faulted cable. Only when they have become permanent such ground faults can be removed selectively by the short-circuit protection.

But such intermittent ground faults already bear the risk of causing thermal damage to equipment. This is why devices 7SJ80 feature a protective function that is able to detect such intermittent ground faults and accumulates their duration. If the sum reaches a configurable value within a certain time, the limit of the thermal load capacity has been reached. If the ground faults are distributed over a long period of time or if the ground fault goes off and does not re-ignite after some time, the equipment under load is expected to cool down. Tripping is not necessary in this case.

Applications

- Protection from intermittent ground faults which occur, e.g. in cables due to poor insulation or water ingress in cable joints.

2.13.1 Description

Acquisition of Measured Quantities

The intermittent ground fault can either be detected via the ordinary ground current input (I_N), the sensitive ground current input (I_{NS}), or it is calculated from the sum of the three phase currents ($3 I_0$). Unlike the overcurrent protection which uses the fundamental wave, the intermittent ground fault protection creates the r.m.s. value of this current and compares it to a settable threshold **Iie>**. This method accounts for higher order harmonics contents (up to 400 Hz) and for the direct component since both factors contribute to the thermal load.

Pickup/Tripping

If the pickup value **Iie>** is exceeded, the pickup indication „IIE Fault det“ (see Figure 2-96) is generated. The pickups are also counted; when the counter content reaches the value of parameter **Nos.det.**, the indication „Intermitt.EF“ is output. A stabilized pickup is obtained by prolonging the pickup indication „IIE Fault det“ by a settable time **T-det.ext.**. This stabilization is especially important for the coordination with existing static or electromechanical overcurrent relays.

The duration of the stabilized pickups „IIE stab.Flt“ is summated with an integrator **T-sum det.**. If the accumulated pickup time reaches a settable threshold value, a corresponding message is generated („IEF Tsum exp.“). Tripping takes place, however, only while a ground fault is present (message „IEF Trip“). The trip command is maintained during the entire minimum tripping time specified for the device, even if the ground fault is of short duration. After completion of the tripping command all memories are reset and the protection resumes normal condition.

The (much longer) resetting time **T-reset** (message „IEF Tres run.“) is launched simultaneously with **T-sum det.** when a ground fault occurs. Unlike **T-sum det.**, each new ground fault resets this time to its initial value and it expires anew. If **T-reset** expires and no new ground fault is recorded during that time, all memories are reset and the protection resumes normal position. **T-reset** thus determines the time during which the next ground fault must occur to be processed yet as intermittent ground fault in connection with the previous fault. A ground fault that occurs later will be considered a new fault event.

The message „IIE Fault det“ will be entered in the fault log and reported to the system interface only until the message „Intermitt.EF“ is issued. This prevents a burst of messages. If the message is allocated to an LED or a relay, this limitation does not apply. This is accomplished by doubling the message (message numbers 6924, 6926).

Interaction with the Automatic Reclosure Function

Automatic reclosure is not an effective measure against intermittent ground faults as the function only trips after repeated detection of a fault or after expiration of the summation monitoring time **T-sum det.** and besides this, its basic design is to prevent thermal overload. For these reasons, the intermittent ground fault protection is not implemented as starting feature of the automatic reclosing function.

Interaction with Breaker Failure Protection

A pickup that is present when the time delay **TRIP - Timer** has expired is interpreted by the breaker failure protection as a criterion for a tripping failure. Since permanent pickup is not ensured after a tripping command by the intermittent ground fault protection, cooperation with the breaker failure protection is not sensible. Therefore, this function is not activated by the intermittent ground fault protection.

Logic Diagram

The following figure shows the logic diagram for the intermittent ground fault protection function.

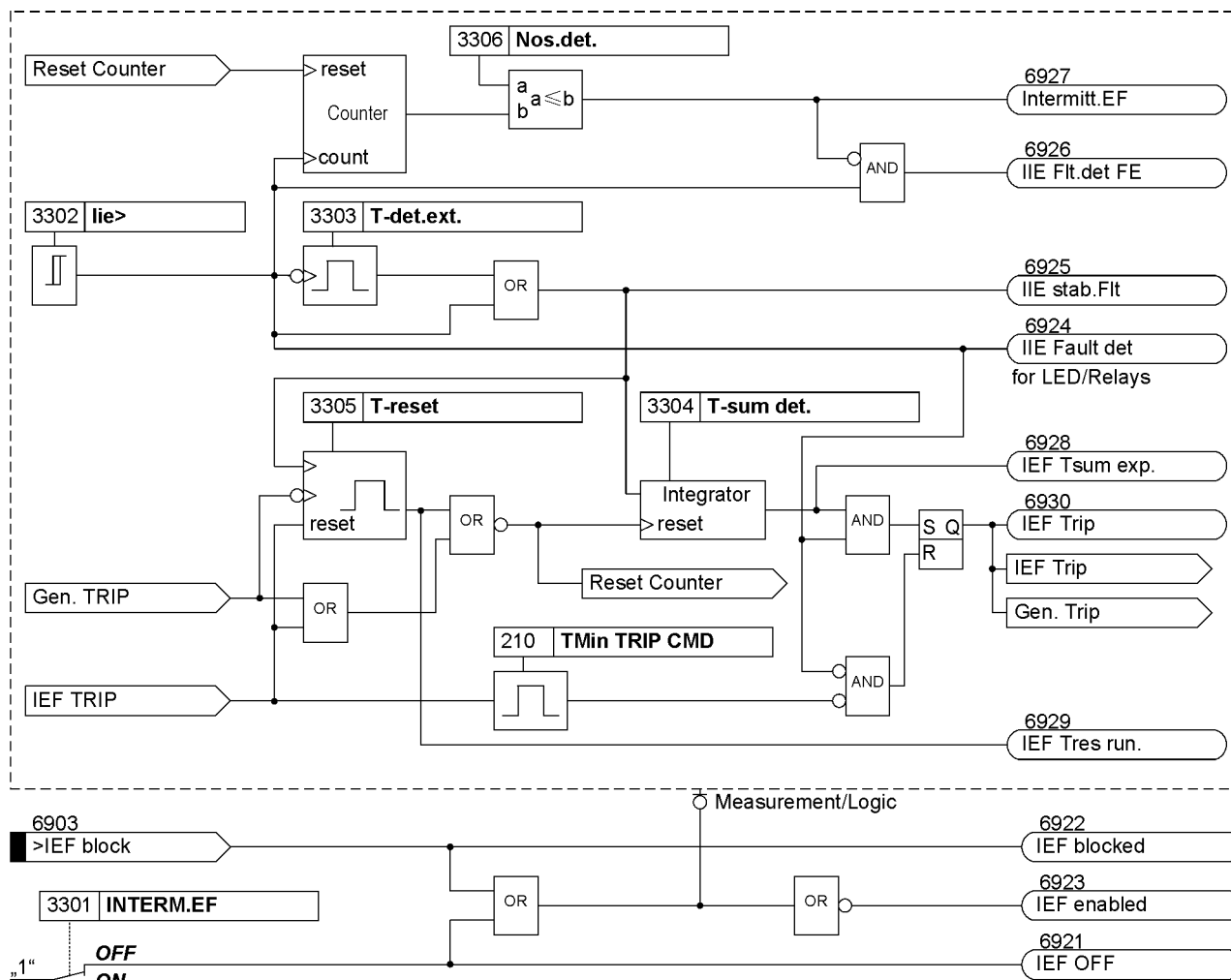

Figure 2-96 Logic diagram of the intermittent ground fault protection – principle

Fault Logging

A fault event and thus fault logging is initiated when the non-stabilized IiE Element picks up for the first time. A message „IIE Fault det“ is produced. The message „IIE Fault det“ is issued and entered in the fault log (and reported to the system interface) so often until the number of pickups „IIE Fault det“ has reached the value set for parameter **Nos. det.**. When this happens, the message „Intermitt.EF“ is issued and „IIE Fault det“ is blocked for the fault log and the system interface. This method accounts for the fact that the IiE Element may also pick up for a normal short-circuit. In this case the pickup does not launch the alarm „Intermitt.EF“.

Intermittent ground faults may cause other overcurrent elements to pick up (e.g. 50-1, 50N-1, 50Ns-1), which may result in a burst of messages. In order to avoid an overflow of the fault log, its messages are no longer entered in the fault log after detection of intermittent ground faults (indication „Intermitt.EF“), unless they cause a trip command. If an intermittent ground fault has been detected, the following pickup messages of the time overcurrent protection will still be reported without restraint (see Table 2-14):

Table 2-14 Unrestricted Messages

FNo.	Message	Description
1800	„50-2 picked up“	50-2 picked up
2642	„67-2 picked up“	67-2 picked up
7551	„50-1 InRushPU“	50-1 InRush picked up
7552	„50N-1 InRushPU“	50N-1 InRush picked up
7553	„51 InRushPU“	51 InRush picked up
7554	„51N InRushPU“	51N InRush picked up
7559	„67-1 InRushPU“	67-1 InRush picked up
7560	„67N-1 InRushPU“	67N-1 InRush picked up
7561	„67-TOC InRushPU“	67-TOC InRush picked up
7562	„67N-TOCInRushPU“	67N-TOC InRush picked up
7565	„Ia InRush PU“	Phase A InRush picked up
7566	„Ib InRush PU“	Phase B InRush picked up
7567	„Ic InRush PU“	Phase C InRush picked up
7564	„Gnd InRush PU“	Ground InRush picked up

Table 2-15 shows all messages subject to a restraint mechanism avoiding a message burst during an intermittent ground fault:

Table 2-15 Buffered Messages

FNo.	Message	Explanation
1761	„50(N)/51(N) PU“	50(N)/51(N) picked up
1762	„50/51 Ph A PU“	50/51 Phase A picked up
1763	„50/51 Ph B PU“	50/51 Phase B picked up
1764	„50/51 Ph C PU“	50/51 Phase C picked up
1767	„50-3 picked up“	50-3 Element picked up
1810	„50-1 picked up“	50-1 picked up
1820	„51 picked up“	51 picked up
1765	„50N/51NPickedup“	50N picked up
1768	„50N-3 picked up“	50N-3 Element picked up
1831	„50N-2 picked up“	50N-2 picked up
1834	„50N-1 picked up“	50N-1 picked up
1837	„51N picked up“	51N picked up
2691	„67/67N pickedup“	67/67N picked up
2697	„67-3 picked up“	67-3 Element picked up
2660	„67-1 picked up“	67-1 picked up
2670	„67-TOC pickedup“	67-TOC picked up
2692	„67 A picked up“	67/67-TOC Phase A picked up
2693	„67 B picked up“	67/67-TOC Phase B picked up
2694	„67 C picked up“	67/67-TOC Phase C picked up
2698	„67N-3 picked up“	67N-3 Element picked up
2646	„67N-2 picked up“	67N-2 picked up
2681	„67N-1 picked up“	67N-1 picked up
2684	„67N-TOCPickedup“	67N-TOC picked up
2695	„67N picked up“	67N/67N—TOC picked up
5159	„46-2 picked up“	46-2 picked up
5165	„46-1 picked up“	46-1 picked up

FNo.	Message	Explanation
5166	„46-TOC pickedup“	46-TOC picked up
1215	„64 Pickup“	64 displacement voltage pick up
1221	„50Ns-2 Pickup“	50Ns-2 picked up
1224	„50Ns-1 Pickup“	50Ns-1 picked up
1227	„51Ns Pickup“	51Ns picked up
6823		Startup supervision Pickup

Before they are entered in the fault log (event buffer) and transmitted to the system interface or CFC, the indications of Table 2-15 are buffered (starting with the incoming indication „Intermitt.EF“). The buffering does not apply to signaling to relays and LEDs as it is required by time-graded protection systems for reverse interlocking. The buffer can store a maximum of two status changes (the most recent ones) for each indication.

Buffered messages are signaled to the fault log, CFC and to the system interface with the original time flag only when a TRIP command is initiated by a protection function other than the intermittent ground fault protection. This ascertains that a pickup, although delayed, is always signaled in association with each TRIP command.

All pickup messages which usually do not occur during an intermittent ground fault are not affected by this mechanism. Among others this includes the pickup and TRIP commands of the following protective functions:

- Breaker failure protection,
- Overload protection,
- Frequency protection
- Voltage protection and
- QU protection.

The pickup signals of these functions will still be logged immediately. A TRIP command of one of these protective functions will cause the buffered messages to be cleared since no connection exists between tripping function and buffered message.

A fault event is cleared when the time **T-reset** has expired or the TRIP command „IEF Trip“ has been terminated.

Terminating a fault event for the intermittent ground fault protection thus is a special case. It is the time **T-reset** that keeps the fault event opened and not the pickup.

2.13.2 Setting Notes

General

The protection function for intermittent ground faults can only take effect and is only accessible if the current to be evaluated was configured in address 133, **INTERM.EF** (with *Ignd* or with *310* or with *Ignd,sens.*). If not required, this function is set to **Disabled**.

The function can be turned **ON** or **OFF** under address 3301 **INTERM.EF**.

The pickup threshold (r.m.s. value) is set in address 3302 **Iie>**. A rather sensitive setting is possible to respond also to short ground faults since the pickup time shortens as the current in excess of the setting increases. The setting range depends on the selection of the current to be evaluated at address 133 **INTERM.EF**.

The pickup time can be prolonged at address 3303 **T-det.ext.**. This pickup stabilization is especially important for the coordination with existing analog or electromechanical overcurrent relays. The time **T-det.ext.** can also be disabled (**T-det.ext.** = 0).

The stabilized pickup starts the counter **T-sum det.**. This counter is stopped but not reset when the picked up function drops out. Based on the last counter content the counter resumes counting when the stabilized

function picks up next. This sum of individual pickup times, which are to initiate tripping, is set at address 3304 **T-sum det..** It represents one of the four selectivity criteria (pickup value **lie>**, detection extension time **T-det.ext.**, counter **T-sum det.** and reset time **T-reset**) for coordinating the relays on adjacent feeders and is comparable to the time grading of the time overcurrent protection. The relay in the radial network which is closest to the intermittent fault and picks up, will have the shortest summation time **T-sum det..**

The reset time, after which the summation is reset in healthy operation and the protection resumes normal status, is configured to **T-reset** at address 3305.

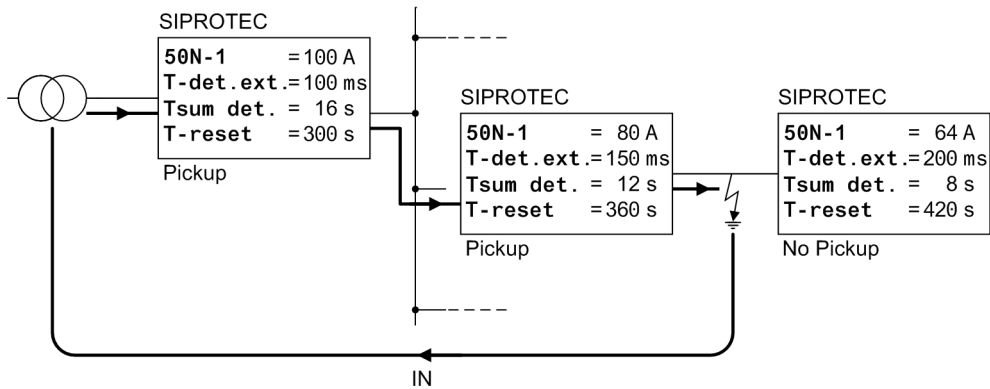

Figure 2-97 Example of selectivity criteria of the intermittent ground fault protection

Address 3306 **Nos.det.** specifies the number of pickups after which a ground fault is considered intermittent.

2.13.3 Settings

The table indicates region-specific default settings. Column C (configuration) indicates the corresponding secondary nominal current of the current transformer.

Addr.	Parameter	C	Setting Options	Default Setting	Comments
3301	INTERM.EF		OFF ON	OFF	Intermittent earth fault protection
3302	lie>	1A	0.05 .. 35.00 A	1.00 A	Pick-up value of interm. E/F stage
		5A	0.25 .. 175.00 A	5.00 A	
3302	lie>	1A	0.05 .. 35.00 A	1.00 A	Pick-up value of interm. E/F stage
		5A	0.25 .. 175.00 A	5.00 A	
3302	lie>		0.005 .. 1.500 A	1.000 A	Pick-up value of interm. E/F stage
3303	T-det.ext.		0.00 .. 10.00 sec	0.10 sec	Detection extension time
3304	T-sum det.		0.00 .. 100.00 sec	20.00 sec	Sum of detection times
3305	T-reset		1 .. 600 sec	300 sec	Reset time
3306	Nos.det.		2 .. 10	3	No. of det. for start of int. E/F prot

2.13.4 Information List

No.	Information	Type of Information	Comments
6903	>IEF block	SP	>block interm. E/F prot.
6921	IEF OFF	OUT	Interm. E/F prot. is switched off
6922	IEF blocked	OUT	Interm. E/F prot. is blocked
6923	IEF enabled	OUT	Interm. E/F prot. is active
6924	IIE Fault det	OUT	Interm. E/F detection stage lie>
6925	IIE stab.Flt	OUT	Interm. E/F stab detection
6926	IIE Flt.det FE	OUT	Interm.E/F det.stage lie> f.Flt. ev.Prot
6927	Intermitt.EF	OUT	Interm. E/F detected
6928	IEF Tsum exp.	OUT	Counter of det. times elapsed
6929	IEF Tres run.	OUT	Interm. E/F: reset time running
6930	IEF Trip	OUT	Interm. E/F: trip
6931	lie/In=	VI	Max RMS current value of fault =
6932	Nos.IIE=	VI	No. of detections by stage lie>=

2.14 Dir. Intermittent earth fault protection

The directional intermittent ground fault protection is designed to selectively detect intermittent ground faults in compensated cable systems.

Intermittent ground faults in compensated cable systems are usually characterized by the following properties:

- Very short high ground current pulses (up to several hundred amperes) with a duration of less than 1 ms;
- They are self-extinguishing and re-ignite within one half period up to several periods, depending on the power system conditions and the fault characteristic.
- They can persist over longer periods (many seconds to minutes) and develop into static faults.

Such intermittent ground faults are frequently caused by weak insulation, e.g. due to decreased water resistance of old cables.

Ground fault functions based on fundamental component measured values are primarily designed to detect static ground faults and do not always operate correctly in the event of intermittent ground faults. The function described here evaluates specifically the ground current pulses and puts them into relation with the displacement voltage to determine the direction.

Applications

- Directional protection against intermittent ground faults which occur, e.g. in cables due to poor insulation or water ingress in cable joints.

2.14.1 Description

Activating the Function

The function is only available if the device is equipped with a sensitive ground current input.

For voltage connection 213 **VT Connect. 3ph = Vab, Vbc** or **Vab, Vbc, Vx** or **Vab, Vbc, VSyn** or **Vph-g, VSyn** and for 250 **50/51 2-ph prot = ON**, the directional intermittent ground fault protection is ineffective. V0 cannot be formed for these connection types.

The function is blocked in case of a measuring voltage failure under the condition that the fuse-failure monitor is configured for the functioning in a grounded system (see Chapter 2.11.1, Fuse-Failure Monitor).

Furthermore, the function can be blocked externally using the binary input signal „>dIEF block“.

Measurand Acquisition

The intermittent ground fault current 3I0 is measured exclusively via the sensitive ground current input INs (4th current transformer input) of the device.

Also the displacement voltage Ven or 3 · V0 is required to determine the direction. The displacement voltage Ven can be applied directly to the device, or the summation voltage 3 · V0 can be calculated from the three phase-to-ground voltages.

If the displacement voltage is calculated, then:

$$3 \cdot V_0 = V_A + V_B + V_C$$

If the displacement voltage is directly applied to the device, then V0 is the voltage at the device terminals. It is not affected by parameter **Vph** / **Vdelta** (address 206).

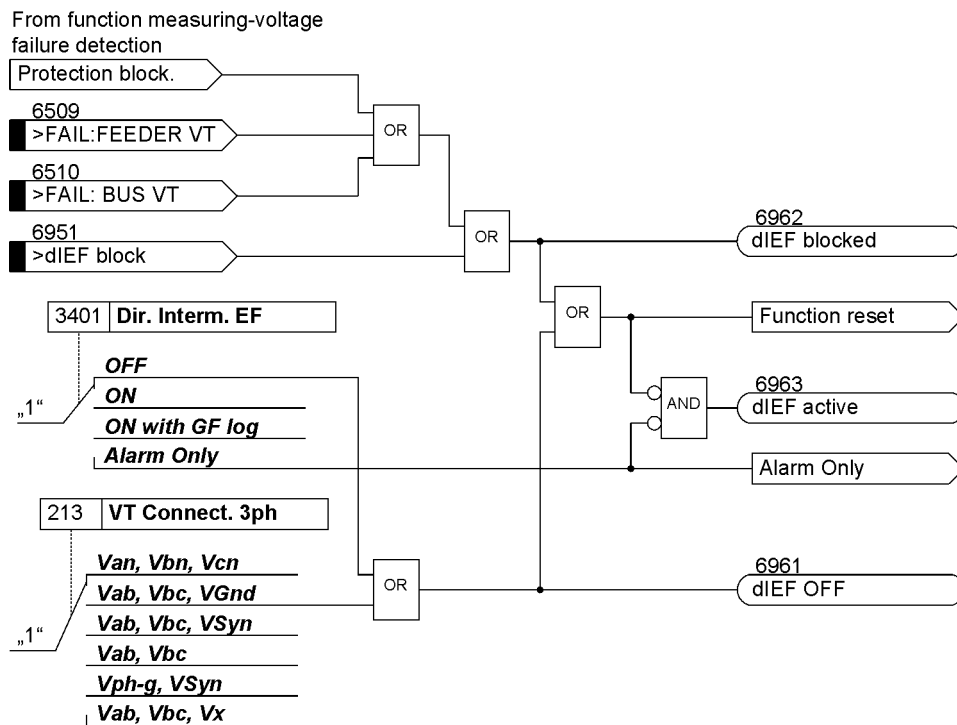

Figure 2-98 Activation of the directional intermittent ground fault protection

Fault Log, Ground Fault Log, Fault Recording

Parameter **Dir. Interm. EF** allows you to define the type of fault handling and fault logging. If set to **ON**, tripping is possible and a fault log is generated. If set to **ON with GF log**, tripping is possible, a fault log and a ground fault log are generated. If set to **Alarm Only**, no tripping is possible. Only an alarm is generated. Furthermore, only a ground fault log is created.

The raising pickup of the function (indication 6972 „dIEF pick up“) is the criterion for opening the ground fault log.

Logic

The following figure shows the logic diagram of the directional intermittent ground fault protection function.

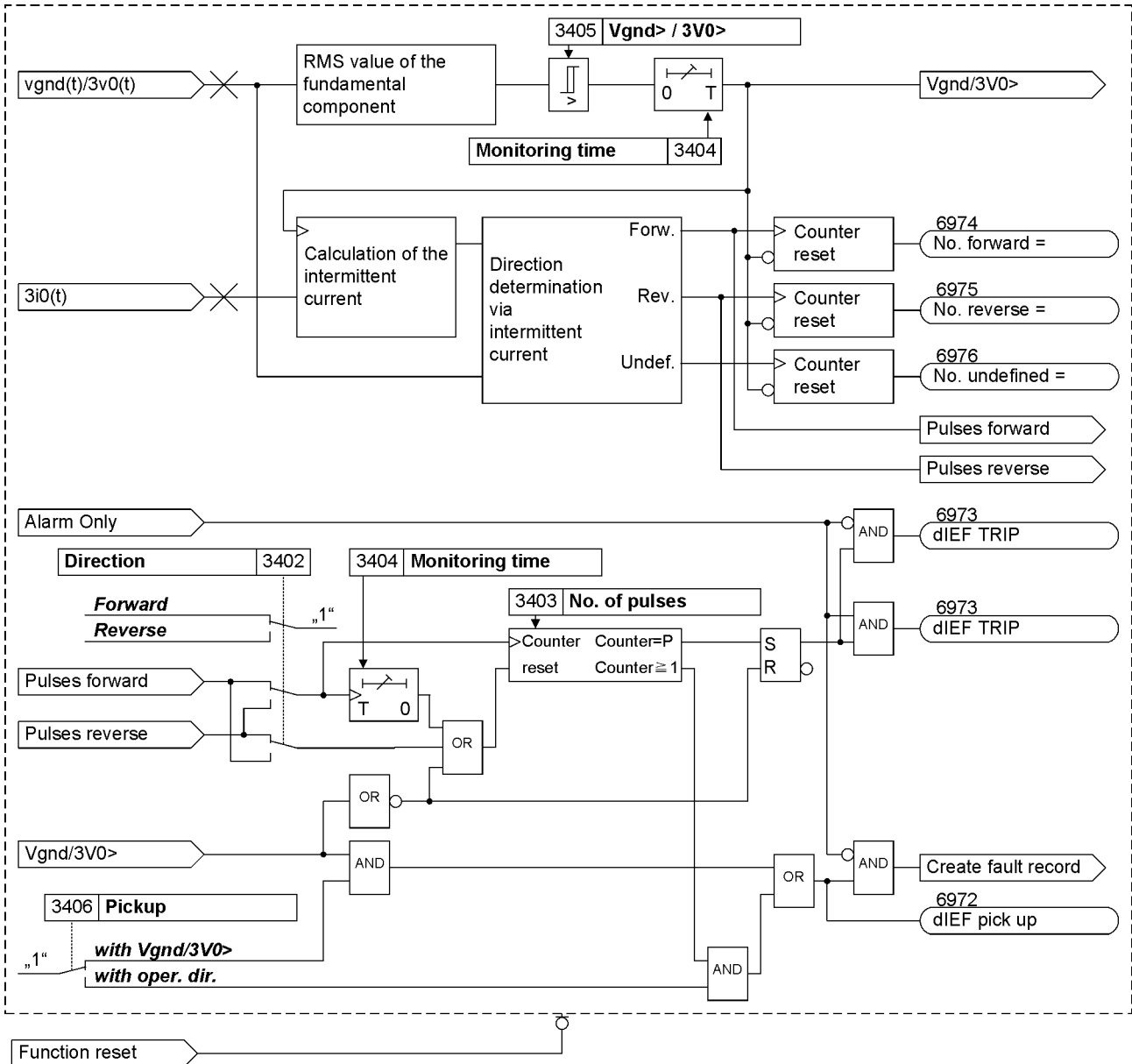

Figure 2-99 Logic diagram of the directional intermittent ground fault protection

Direction Determination

The ground fault is detected by evaluating the fundamental component of the displacement voltage. The sensitivity is determined using the settable threshold value $V_{gnd} > / 3V0 >$. Direction determination is started after the ground fault has been detected. For this purpose, the igniting current pulses are extracted from the ground current signal. The igniting current pulse and the associated maximum displacement voltage over time are compared with regard to their phase relationship. The fault direction forward or reverse is derived from this comparison. Each detected ignition pulse receives a direction information. If no clear direction determination is possible, the direction information pertaining to the pulse is undefined. The direction results of the recurring ignition pulses are counted and are available as value indication if their value is different than zero.

Pickup

The setting of parameter **Pickup** defines under which conditions pickup is detected and fault recording started. For **with Vgnd/3V0>**, pickup is initiated once the threshold **Vgnd> / 3V0>** has been exceeded. For **with oper. dir.**, pickup is initiated when a pulse is detected in the direction specified at address 3402. The pickup disappears when the displacement voltage has fallen below the threshold **Vgnd> / 3V0>** and the time **Monitoring time** has expired.

Alarm/Trip

The setting of parameter **Direction** defines whether the function operates in forward or in reverse direction. The pulses in the specified direction are counted. If the pulse counter reaches the threshold value set in parameter **No. of pulses**, the function trips or generates an alarm. It is possible that not every ignition pulse is recognized as such. If two ignition pulses are very close to one another in respect of time, they may not be detected separately. This is not relevant from the protection perspective, because during an intermittent fault many ignition pulses occur and the counter threshold is certainly reached.

The directional pulse counter is reset under the following conditions:

- A different direction than the set **Direction** is detected. An undefined direction result does not reset the counter.
- The monitoring time **Monitoring time** has elapsed. No other pulse in the set direction was detected during that time. This time can be understood as a criterion for the disappearing of the intermittent fault. The function thus also drops out if the intermittent fault develops into a static fault.
- V0 is lower than the set threshold **Vgnd> / 3V0>** and the time **Monitoring time** has expired.

Interaction with other Functions

The directional intermittent ground fault protection does not interact with the automatic reclosing function. The function cannot start the automatic reclosing function.

The directional intermittent ground fault protection interacts with the circuit-breaker failure protection. The function starts the circuit-breaker failure protection.

2.14.2 Setting Notes

General

Configuration of the protection functions at address 134 **Dir. Interm. EF** defines whether the directional intermittent ground fault protection is **Enabled** or **Disabled**.

At address 3401 **Dir. Interm. EF** the directional ground fault protection is switched on or off. The following setting options are available:

- **ON** enables the function with tripping and fault record log.
- **ON with GF log** enables the function with tripping, fault record log and ground fault log.
- **Alarm Only** generates the ground fault log only. Tripping and fault record log are not possible.
- **OFF** disables the function.

The pickup threshold for the displacement voltage is set at address 3405 **Vgnd> / 3V0>**. Exceeding this threshold is the criterion for detecting the intermittent ground fault.

The direction to be protected **Forward** or **Reverse** is set in address 3402 **Direction**.

Address 3403 **No. of pulses** allows you to specify how many pulses must be detected in the set direction before the alarm or tripping is initiated. It is possible that not every ignition pulse is recognized as such. If two ignition pulses are very close to one another in respect of time, they may not be detected separately. This is

not relevant from the protection perspective, because during an intermittent fault many ignition pulses occur and the counter threshold is certainly reached.

At address 3404 **Monitoring time** you set the monitoring time after detection of the direction pulse in the direction parameterized at 3402. If the time has expired before the number set at 3403 **No. of pulses** has been reached, the associated counter is reset. This time is a criterion for the disappearing of the intermittent fault.

At address 3406 **Pickup** you can set the criterion for the pickup of the function. For *with Vgnd/3V0*> pickup takes place as soon as the threshold *Vgnd*> / *3V0*> has been exceeded, regardless of whether a real intermittent ground fault is present or not. For *with oper. dir.*, recording starts when a direction pulse in the direction parameterized at 3402 has been detected.

2.14.3 Settings

Addr.	Parameter	Setting Options	Default Setting	Comments
3401	Dir. Interm. EF	OFF ON ON with GF log Alarm Only	OFF	Dir. Intermittent earth fault protection
3402	Direction	Forward Reverse	Forward	Direction to be protected
3403	No. of pulses	2 .. 50	5	Pulse no. for detecting the interm. E/F
3404	Monitoring time	0.04 .. 10.00 sec	2.00 sec	Monitoring time after pickup detected
3405	Vgnd> / 3V0>	2.0 .. 100.0 V	20.0 V	Vgnd> measured / 3V0> calculated
3406	Pickup	with Vgnd/3V0> with oper. dir.	with Vgnd/3V0>	Pickup of the function

2.14.4 Information List

No.	Information	Type of Information	Comments
6951	>dIEF block	SP	>Block directional interm. E/F prot.
6961	dIEF OFF	OUT	Dir. Interm. E/F prot. is switched off
6962	dIEF blocked	OUT	Dir. Interm. E/F prot. is blocked
6963	dIEF active	OUT	Dir. Interm. E/F prot. is active
6972	dIEF pick up	OUT	dIEF: pick up
6973	dIEF TRIP	OUT	dIEF: Trip
6974	No.forward=	VI	dIEF: No. of detected forward pulses =
6975	No.reverse=	VI	dIEF: No. of detected reverse pulses =
6976	No.undef.=	VI	dIEF: No. of detected undefined pulses =
6979	dIEF ALARM	OUT	dIEF: Alarm

2.15 Automatic Reclosing System 79

From experience, about 85 % of insulation faults associated with overhead lines are arc short circuits which are temporary in nature and disappear when protection takes effect. This means that the line can be connected again. The reconnection is accomplished after a dead time via the automatic reclosure function.

If the fault still exists after automatic reclosure (arc has not disappeared, there is a metallic fault), then the protective elements will re-trip the circuit breaker. In some systems, several reclosing attempts are performed.

Applications

- The automatic reclosure system integrated in the 7SJ80 can also be controlled by an external protection device (e.g. backup protection). For this application, a signal exchange must occur between 7SJ80 and the external protection device via binary inputs and outputs.
- It is also possible to allow the relay 7SJ80 to work in conjunction with an external reclosing device.
- The automatic reclosure system can also operate in interaction with the integrated synchronization function or with an external synchrocheck.
- Since the automatic reclosing function is not applied when the 7SJ80 is used to protect generators, transformers, cables and reactors etc., it should be disabled for these applications.

2.15.1 Program Execution

The 7SJ80 is equipped with an integrated three-pole, single-shot and multi-shot automatic reclosure (AR). Figure 2-100 shows an example of a timing diagram for a successful second reclosure.

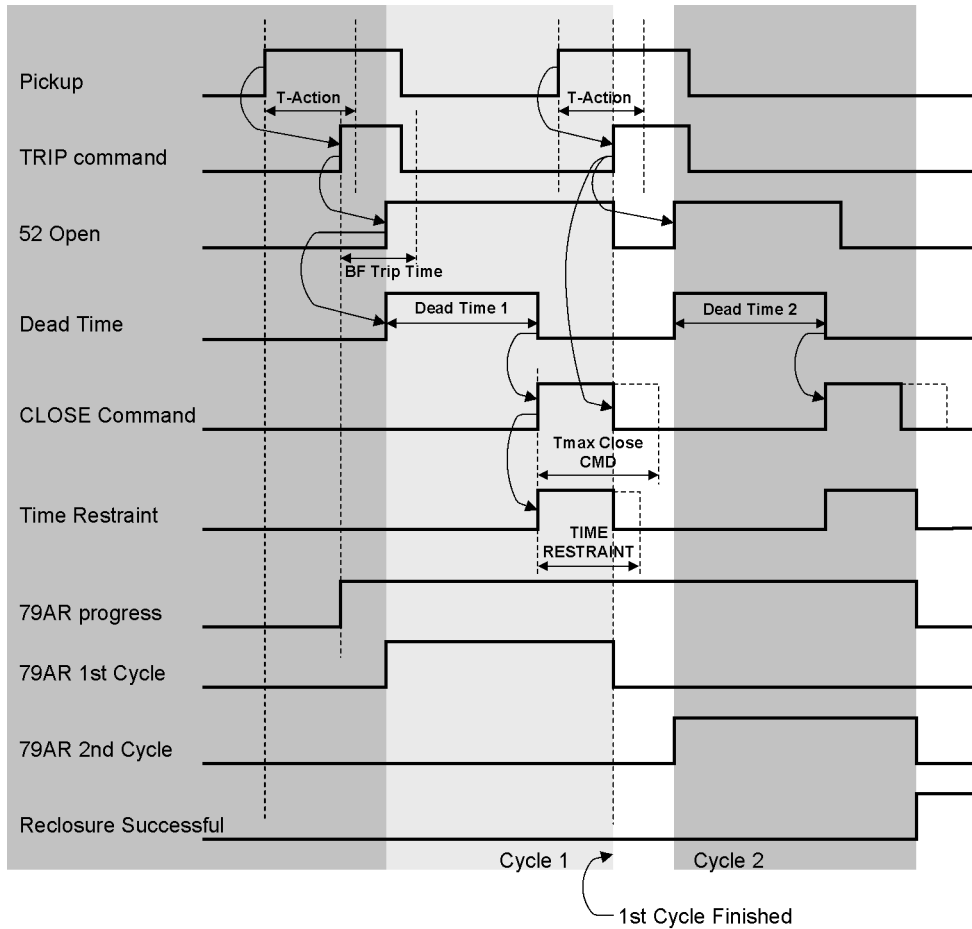

Figure 2-100 Timing diagram showing two reclosing shots, first cycle unsuccessful, second cycle successful

The following figure shows an example of a timing diagram showing for two unsuccessful reclosing shots, with no additional reclosing of the circuit breaker.

The number of reclose commands initiated by the automatic reclosure function are counted. A statistical counter is available for this purpose for the first and all subsequent reclosing commands.

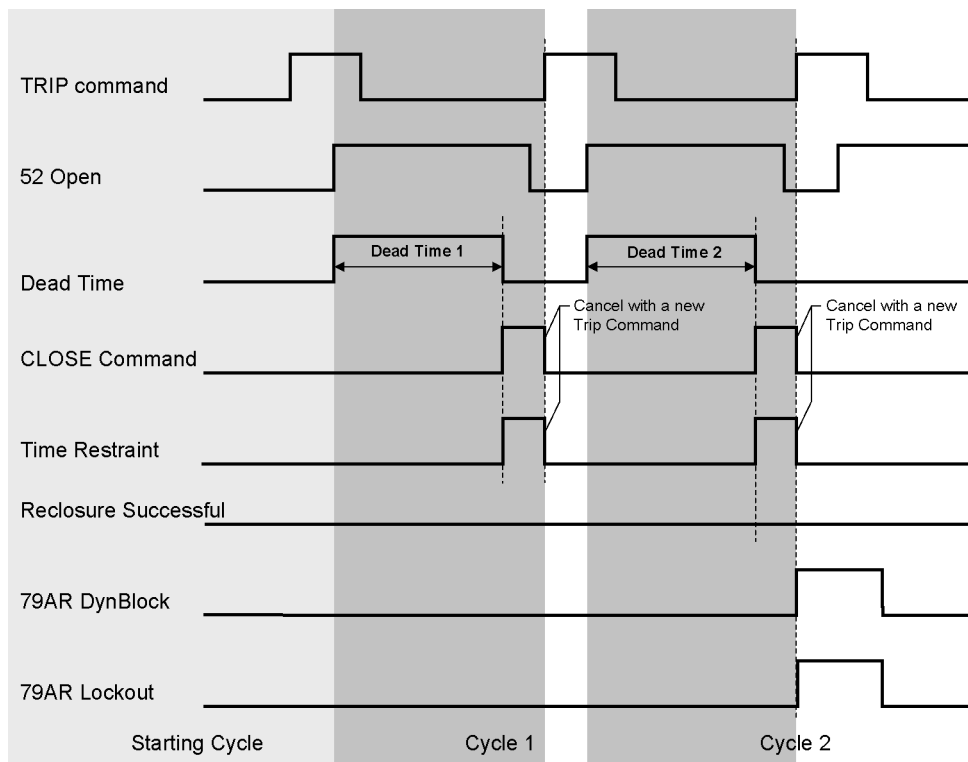

Figure 2-101 Timing diagram showing two unsuccessful reclosing shots

Initiation

Initiation of the automatic reclosing function can be caused by internal protective functions or externally via binary inputs. The automatic reclosing system can be programmed in such manner that any of the elements of Table 2-16 can initiate (**Starts 79**), not initiate (**No influence**), or block reclosing (**Stops 79**):

Table 2-16 Initiating automatic reclosure

Non-directional start	Directional start	Start other
50-1	67-1	Sensitive Ground Fault Protection (50Ns, 51Ns)
50N-1	67N-1	Negative Sequence Protection 46
50-2	67-2	BINARY INPUT
50-3	67-3	
50N-2	67N-2	
50N-3	67N-3	
51	67-TOC	
51N	67N-TOC	

On initiation, the automatic reclosure function is informed that a trip command was issued and the respective reclosing program is now being executed.

The binary input messages 2715 „>Start 79 Gnd“ and 2716 „>Start 79 Ph“ for starting an automatic reclosure program can also be activated via CFC (fast PLC task processing). Automatic reclosure can thus be initiated via any messages (e.g. protective pickup) if address 7164 **BINARY INPUT** is set to **Starts 79**.

Action Time

The action time (address 7117) monitors the time between a device pickup and the trip command of a protection function configured as starter. The action time is launched when pickup of any function is detected, which is set as source of the automatic reclosure program. Protection functions which are set to **Alarm Only** or which in principle should not start a reclosing program do not trigger the action time.

If a protection function configured as starter initiates a trip command during the action time, the automatic reclosure program is started. Trip commands of a protection function configured as starter occurring in the time between expiration of the action time and dropout of the device pickup cause the dynamic blocking of the automatic reclosing program. Trip commands of protection functions which are not configured as starter do not affect the action time.

If the automatic reclosure program interacts with an external protection device, the general device pickup for starting the operating time is communicated to the automatic reclosing program via binary input 2711 „>79 Start“.

Delay of Dead Time Start

After start of the automatic reclosure function, the dead time start can be delayed by pickup of the binary input message 2754 „>79 DT St.DeLay“. The dead time is not initiated as long as the binary input is active. Start occurs only on cleared binary input. The delay of the dead time start can be monitored via parameter 7118 **T DEAD DELAY**. If the time elapses and the binary input is still active, the **Automatic Reclosing System 79** changes to the status of the dynamic blocking via (2785 „79 DynBlock“). The maximum time delay of the dead time start is logged by message 2753 „79 DT delay ex.“.

Reclosing Programs

Depending on the type of fault, two different reclosing programs can be used. Here the following applies:

- The single phase fault (**ground** fault) reclosing program applies if all fault protection functions that initiate automatic reclosure detected a phase-to-ground fault. The following conditions must apply: only one phase, only one phase and ground or only ground have picked up. This program can also be started via a binary input.
- The multiple phase fault (**phase** fault) reclosing program applies to all other cases. That is, when elements associated with two or more phases pick up, with or without the pickup of Ground elements, such as negative sequence elements. This program can be started via a binary input as well.

The reclosure program evaluates only elements during pickup as elements dropping out may corrupt the result if they drop out at different times when opening the circuit breaker. Therefore, the Ground fault reclosure program is executed only when the elements associated with one particular phase pick up until the circuit breaker is opened; all others conditions will initiate the phase fault program.

For each of the programs, up to 9 reclosing attempts can be separately programmed. The first four reclosing attempts can be set differently for each of the two reclosing programs. The fifth and each of the following automatic reclosures will correspond to the fourth dead time.

Reclosing Before Selectivity

For the automatic reclosure sequence to be successful, faults on any part of the line must be cleared from the feeding line end(s) within the same – shortest possible – time. Usually, therefore, an instantaneous protection element is set to operate before an automatic reclosure. Fast fault termination has thus priority over selectivity aspects as the reclosing action aims at maintaining normal system operation. For this purpose, all protection functions which can initiate the automatic reclosure function are set in such manner that they may trip instantaneously or with a very small time delay before automatic reclosure.

When the final trip takes place, i.e. no automatic reclosing can be expected, the protection is to trip with delay according to the grading coordination chart of the system, since the selectivity has the priority in this case. See

also the information under the side heading "Interaction with the Automatic Reclosing Function" in the Setting Notes of the time overcurrent protection functions.

Single-Shot Reclosing

When a trip signal is programmed to initiate the automatic reclosure, the appropriate automatic reclosing program will be executed. Once the circuit breaker has opened, a dead time interval in accordance with the type of fault is started (see also margin heading "Reclosing Programs"). Once the dead time interval has elapsed, a closing signal is issued to reclose the circuit breaker. A blocking time interval **TIME RESTRAINT** is started at the same time. Within this restraint time it is checked whether the automatic reclosure was performed successfully. If a new fault occurs before the restraint time elapses, the automatic reclosing function is dynamically blocked causing the final tripping of the circuit breaker. The dead time can be set individually for each of the two reclosing programs.

Criteria for opening the circuit breaker may either be the auxiliary contacts of the circuit breaker or the dropout of the general device pickup if auxiliary contacts are not configured.

If the fault is cleared (successful reclosing attempt), the blocking time expires and automatic reclosing is reset in anticipation of a future fault. The fault is terminated.

If the fault has not been cleared (unsuccessful reclosing attempt), then a final trip signal is initiated by one or more protective elements.

Multi-shot Reclosing

7SJ80 permits up to 9 reclosings. The number can be set differently for the phase fault reclosing program and the Ground fault reclosing program.

The first reclose cycle is, in principle, the same as the single-shot auto-reclosing. If the first reclosing attempt is unsuccessful, this does not result in a final trip, but in a reset of the restraint time interval and start of the next reclose cycle with the next dead time. This can be repeated until the set number of reclosing attempts for the corresponding reclose program has been reached.

The dead time intervals preceding the first four reclosing attempts can be set differently for each of the two reclosing programs. The dead time intervals preceding the fifth reclosing attempts will be equal to the dead time interval that precedes the fourth reclosing attempt.

If one of the reclosing attempts is successful, i.e. the fault disappeared after reclosure, the restraint time expires and the automatic reclosing function is reset. The fault is cleared.

If none of the reclosing attempts is successful, then a final circuit breaker trip (according to the grading coordination chart) will take place after the last allowable reclosing attempt has been performed by the protection function. All reclosing attempts were unsuccessful.

After the final circuit breaker tripping, the automatic reclosing function is dynamically blocked (see below).

Blocking Time

The function of the blocking time has already been described under section "Single-/Multi-Shot Reclosing". The blocking time can be prolonged if the following conditions have been fulfilled.

The time 211 **TMax CLOSE CMD** defines the maximum time during which a close command can apply. If a new trip command occurs before this time has run out, the close command will be canceled. If the time **TMax CLOSE CMD** is set longer than the restraint time **TIME RESTRAINT**, the restraint time will be extended to the remaining close command duration after expiry!

A pickup from a protection function that is set to initiate the automatic reclosing function will also lead to an extension of the blocking time should it occur during this time!

2.15.2 Blocking

Static Blocking

Static blocking means that the automatic reclosing function is not ready to initiate reclosing, and cannot initiate reclosing as long as the blocking signal is present. A corresponding message „79 is NOT ready“ (FNo. 2784) is generated. The static blocking signal is also used internally to block the protection elements that are only supposed to work when reclosing is enabled (see also side title "Reclosing Before Selectivity" further above).

The automatic reclosing function is statically blocked if:

- The signal „>BLOCK 79“ (FNo.2703) is present at a binary input, as long as the automatic reclosing function is not initiated (associated message: „>BLOCK 79“),
- The signal „>CB Ready“ (FNo. 2730) indicates that the circuit breaker disappears via the binary input, if the automatic reclosing function is not initiated (associated message: „>CB Ready“),
- The number of allowable reclosing attempts set for both reclosing programs is zero (associated message: „79 no cycle“),
- No protection functions (parameters 7150 to 7163) or binary inputs are set to initiate the automatic reclosing function (associated message: „79 no starter“),
- The circuit breaker position is reported as being "open" and no trip command applies (associated message: „79 BLK: CB open“). This presumes that 7SJ80 is informed of the circuit breaker position via the auxiliary contacts of the circuit breaker.

Dynamic Blocking

Dynamic blocking of the automatic reclosing function occurs in those cases where the reclosing program is active and one of the conditions for blocking is fulfilled. The dynamic blocking is signaled by the message „79 DynBlock“. The dynamic blocking is associated with the configurable blocking time **SAFETY 79 ready**. This blocking time is usually started by a blocking condition that has been fulfilled. After the blocking time has elapsed, the device checks whether or not the blocking condition can be reset. If the blocking condition is still present or if a new blocking condition is fulfilled, the blocking time is restarted. If, however, the blocking condition no longer exists after the blocking time has elapsed, the dynamic blocking will be reset.

Dynamic blocking is initiated if:

- The maximum number of reclosure attempts has been achieved. If a trip command now occurs within the dynamic blocking time, the automatic reclosure program will be blocked dynamically (indicated by „79 Max. No. Cyc“).
- The protection function has detected a three-phase fault and the device is programmed not to reclose after three-phase faults (indicated by „79 BLK:3ph p.u.“).
- if the maximum waiting period **T DEAD DELAY** for the delay of the dead time initiation by binary inputs expires without binary input „>79 DT St.Delay“ having been disabled during this time period.
- The action time has elapsed without a TRIP command being issued. Each TRIP command that occurs after the action time has expired and before the picked-up element drops out, will initiate the dynamic blocking (indicated by „79 Tact expired“).
- A protection function trips which is to block the automatic reclosure function (as configured). This applies irrespective of the status of the automatic reclosure system (started / not started) if a TRIP command of a blocking element occurs (indicated by „79 BLK by trip“).
- The circuit breaker failure function is initiated.
- The circuit breaker does not trip within the configured time **T-Start MONITOR** after a trip command was issued, thus leading to the assumption that the circuit breaker has failed. (The breaker failure monitoring is primarily intended for commissioning purposes. Commissioning safety checks are often conducted with the circuit breaker disconnected. The breaker failure monitoring prevents unexpected reclosing after the circuit breaker has been reconnected, indicated by „79 T-Start Exp“).

- The circuit breaker is not ready after the breaker monitoring time has elapsed, provided that the circuit breaker check has been activated (address 7113 **CHECK CB?** = *Chk each cycle*, indicated by „79 T-CBreadyExp“).
- The circuit breaker is not ready after maximum extension of the dead time **Max. DEAD EXT.**. The monitoring of the circuit breaker status and the synchrocheck may cause undesired extension of the dead time. To prevent the automatic reclosure system from assuming an undefined state, the extension of the dead time is monitored. The extension time is started when the regular dead time has elapsed. When it has elapsed, the automatic reclosure function is blocked dynamically and the lock-out time launched. The automatic reclosure system resumes normal state when the lock-out time has elapsed and new blocking conditions do not apply (indicated by „79 TdeadMax Exp“).
- Manual closing has been detected (externally) and parameter **BLOCK MC Dur.** ($T \neq 0$) was set so that the automatic reclosing function responds to manual closing,
- Via a correspondingly routed binary input (FNo. 2703 „>BLOCK 79“). If the blocking takes place while the automatic recloser is in normal state, the latter will be blocked statically („79 is NOT ready“). The blocking is terminated immediately when the binary input has been cleared and the automatic reclosure function resumes normal state. If the automatic reclosure function is already running when the blocking arrives, the dynamic blocking takes effect („79 DynBlock“). In this case, the activation of the binary input starts the dynamic blocking time **SAFETY 79 ready**. Upon its expiration, the device checks if the binary input is still activated. If this is the case, the automatic reclosure program changes from dynamic blocking to static blocking. If the binary input is no longer active when the time has elapsed and if no new blocking conditions apply, the automatic reclosure system resumes normal state.

2.15.3 Status Recognition and Monitoring of the Circuit Breaker

Circuit Breaker Status

The detection of the actual circuit breaker status is necessary for the correct functionality of the automatic reclosure function. The circuit breaker status is detected by the circuit breaker auxiliary contacts and is communicated to the device via binary inputs 4602 „>52 - b“ and 4601 „>52 - a“.

Here the following applies:

- If binary input 4601 „>52 - a“ and binary input 4602 „>52 - b“ are used, the automatic reclosure function can detect whether the circuit breaker is open, closed or in intermediate position. If both auxiliary contacts detect that the circuit breaker is open, the dead time is started. If the circuit breaker is open or in intermediate position without a trip command being present, the automatic reclosure function is blocked dynamically if it is already running. If the automatic reclosure system is in normal state, it will be blocked statically. When checking whether a trip command applies, all trip commands of the device are taken into account irrespective of whether the function acts as starting or blocking element on behalf of the automatic reclosure program.
- If only the binary input 4601 „>52 - a“ is allocated, the circuit breaker is considered open if the binary input is not active. If the binary input gets inactive while no trip command of (any) function applies, the automatic reclosure function is blocked. The blocking will be of static nature if the automatic reclosure function is in normal state at this time. If the automatic reclosing function is already running, there will be a dynamic blocking. The dead time is started if the binary input gets inactive following the trip command of a starting element (4601 „>52 - a“ = inactive). An intermediate position of the circuit breaker cannot be detected for this type of allocation.

- If binary input 4602 „>52 - b“ alone is allocated, the circuit breaker is considered open while the binary input is active. If the binary input gets active while no trip command of (any) function applies, the automatic reclosure function is blocked dynamically provided it is already running. Otherwise, there will be a static blocking. The dead time is started if the binary input gets active following the trip command of a starting element. An intermediate position of the circuit breaker cannot be detected for this type of allocation.
- If neither binary input 4602 „>52 - b“ nor 4601 „>52 - a“ are allocated, the automatic reclosure program cannot detect the position of the circuit breaker. In this case, the automatic reclosure function will be controlled exclusively via pickups and trip commands. Monitoring for "52-b without TRIP" and starting the dead time in dependence of the circuit breaker feedback is not possible in this case.

Circuit Breaker Monitoring

The time needed by the circuit breaker to perform a complete reclose cycle can be monitored by the 7SJ80. Breaker failure is detected:

A precondition for a reclosing attempt, following a trip command initiated by a protective relay element and subsequent initiation of the automatic reclosing function, is that the circuit breaker is ready for at least one TRIP-CLOSE-TRIP cycle. The readiness of the circuit breaker is monitored by the device using a binary input „>CB Ready“. In the case where this signal from the breaker is not available, the circuit breaker monitoring feature should be disabled, otherwise reclosing attempts will remain blocked.

- Especially when multiple reclosing attempts are programmed, it is a good idea to monitor the circuit breaker condition not only prior to the first but also to each reclosing attempt. A reclosing attempt will be blocked until the binary input indicates that the circuit breaker is ready to complete another CLOSE-TRIP cycle.
- The time needed by the circuit-breaker to regain the ready state can be monitored by the 7SJ80. The monitoring time **CB TIME OUT** expires for as long as the circuit breaker does not indicate that it is ready via binary input „>CB Ready“ (FNo. 2730). That means if the binary input „>CB Ready“ is cleared, the monitoring time **CB TIME OUT** is started. If the binary input returns before the monitoring time has elapsed, the monitoring time will be canceled and the reclosure process is continued. If the monitoring time runs longer than the dead time, the dead time will be extended accordingly. If the monitoring time elapses before the circuit breaker signals its readiness, the automatic reclosure function will be blocked dynamically.

Interaction with the synchronism check may cause the dead time to extend inadmissibly. To prevent the automatic reclosure function from remaining in an undefined state, dead time extension is monitored. The maximum extension of the dead time can be set at **Max. DEAD EXT.**. The monitoring time **Max. DEAD EXT.** is started when the regular dead time has elapsed. If the synchronism check responds before the time has elapsed, the monitoring time will be stopped and the close command generated. If the time expires before the synchronism check reacts, the automatic reclosure function will be blocked dynamically.

Please make sure that the above mentioned time is not shorter than the monitoring time **CB TIME OUT**.

The time 7114 **T-Start MONITOR** serves for monitoring the response of the automatic reclosure function to a breaker failure. It is activated by a trip command arriving before or during a reclosing operation and marks the time that passes between tripping and opening of the circuit breaker. If the time elapses, the device assumes a breaker failure and the automatic reclosure function is blocked dynamically. If parameter **T-Start MONITOR** is set to ∞ , the start monitoring is disabled.

2.15.4 Controlling Protection Elements

The automatic reclosing function can influence delay times and threshold values of the directional and non-directional time overcurrent protection (control of protection elements). There are three mechanisms:

1. The time overcurrent elements can trip instantaneously depending on the automatic reclosure cycle ($T = 0$), they can remain unaffected by the automatic reclosing function ($T = T$) or they can be blocked ($T = \infty$). For further information see margin heading "Cyclic Control".
2. The automatic reclosing states "AR ready" and "AR not ready" can activate or deactivate the dynamic cold load pickup function. This function allows the threshold values and trip delays of the overcurrent protection elements to be switched (see also Section 2.15.6 and Section 2.4).
3. The time overcurrent protection parameter 1X14A 50(N)-2 ACTIVE or 1X16A 50(N)-3 ACTIVE defines whether the 50(N)-2 or 50(N)-3 elements always operate or only with "79 Auto Reclosing ready" (see Section 2.2).

Cyclic Control

Control of the overcurrent protection stages takes effect by releasing the cycle marked by the corresponding parameter. The cycle zone release is signaled by the indications „79 1.CycZoneRe1“ through „79 4.CycZoneRe1“. If the automatic reclosing function is in idle state, the settings for the starting cycle apply. The settings made here are always in effect when the automatic reclosing system is in idle state.

The parameters are released for each following cycle when issuing the close command and starting the blocking time. Following successful reclosure (blocking time expired) or after returning from blocked condition, the automatic reclosing function goes into idle state. Control of the protection is again assumed by the parameters for the starting cycle.

The following figure illustrates the control of the protection elements 50-2 and 50N-2.

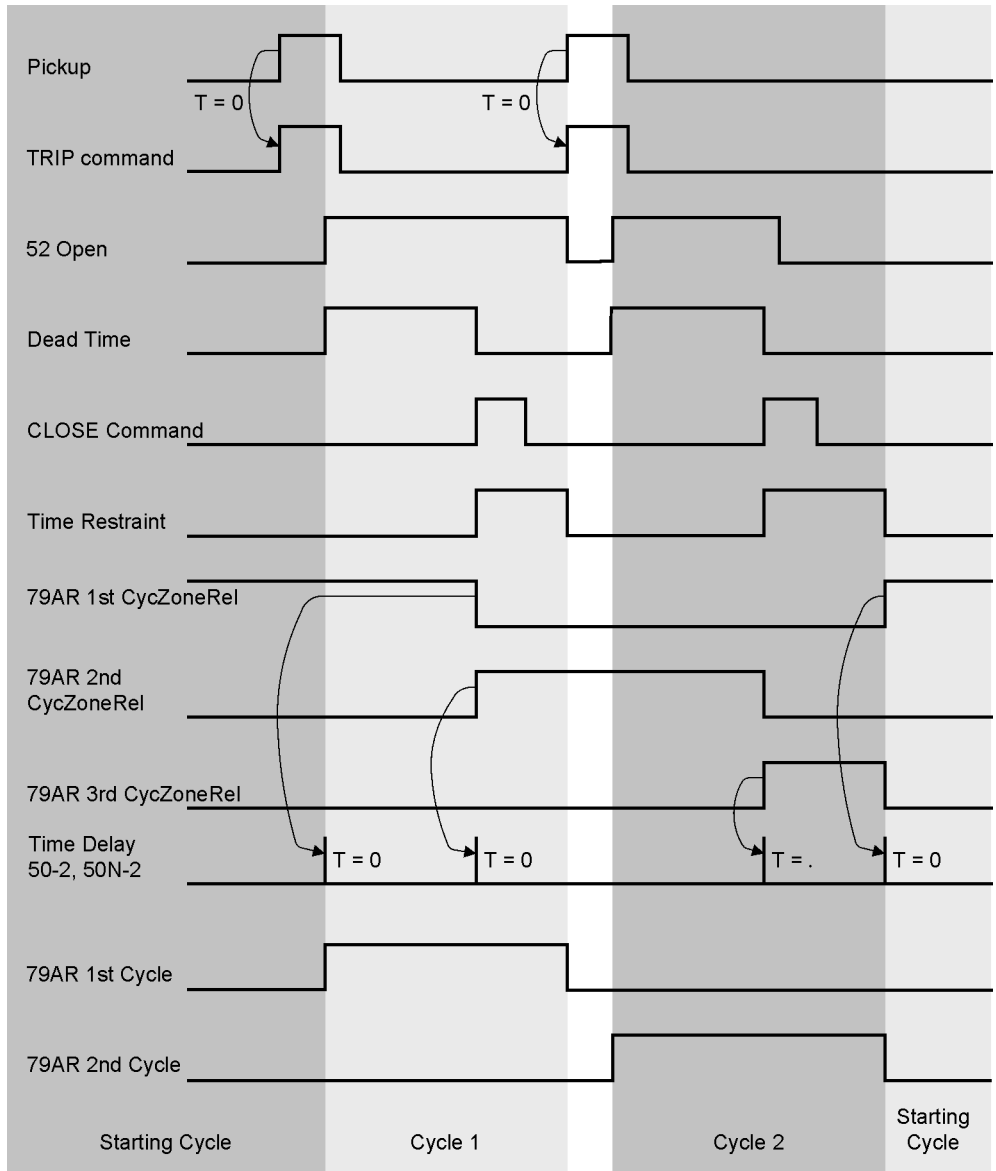

Figure 2-102 Control of protection elements for two-fold, successful automatic reclosure

2.15.5 Zone Sequencing / Fuse Saving Scheme

The zone sequencing / fuse saving scheme is not available for device versions 7SJ8***-**A**-.

It is the task of the zone sequence coordination to harmonize the automatic reclosure function of this device with that of another device that forms part of the same power system. It is a complementary function to the automatic reclosure function and allows, for example, to perform group reclosing operations in radial systems. In case of multiple reclosures, groups may also be in nested arrangement and further high-voltage fuses can be overgraded or undergraded.

Zone sequencing works by blocking certain protection functions depending on the reclosing cycle. This is implemented by the protection elements control (see margin heading "Controlling Protection Elements").

As a special feature, changing from one reclosing cycle to the next is possible without trip command only via pickup/dropout of 50-1 or 50N-1.

The following figure shows an example of a group reclosure at feeder 3. It is assumed that reclosure is performed twice.

With fault F1 on feeder 5, protection devices in the infeed and on feeder 3 pick up. The time delay of the 50-2 Element at protecting feeder 3 is set in such a way that the feeder 3 circuit breaker will clear the fault before the fuse at feeder 5 is damaged. If the fault is cleared, all functions are reset after the restraint time has expired and the fault is terminated. The fuse has therefore also been protected.

If the fault continues to exist, a second reclosing cycle is performed in the same way.

High speed element 50-2 is now blocked at relay protecting Feeder 3. If the fault still remains, only the 50-1 Element continues to be active in Feeder 3 which, however, **overgrades** the fuse with a time delay of 0.4 s. After the fuse operated to clear the fault, the series-connected devices drop out. If the fuse fails to clear the fault, then the 50-1 Element protecting Feeder 3 will operate as backup protection.

The 50-2 Element at the busbar relay is set with a delay of 0.4 seconds, since it supposed to trip the 50-2 elements and the fuses as well. For the second reclosing, the 50-2 Element also has to be blocked to give preference to the feeder relay (50-1 element with 0.4 s). For this purpose, the device has to "know" that two reclosing attempts have already been performed.

In this device, zone sequence coordination must be switched on: When pickup of 50-1 or 50N-1 drops out, zone sequence coordination provokes that the reclosing attempts are counted as well. If the fault still persists after the second reclosure, the 50-1 Element, which is set to 0.9 seconds, would serve as backup protection.

For the busbar fault F2, the 50-2 Element at the bus would have cleared the fault in 0.4 seconds. Zone sequencing enables the user to set a relatively short time period for the 50-2 elements. The 50-1 Element is only used as backup protection. If zone sequencing is not applied, the 50-1 Element is to be used only with its relatively long time period (0.9 s).

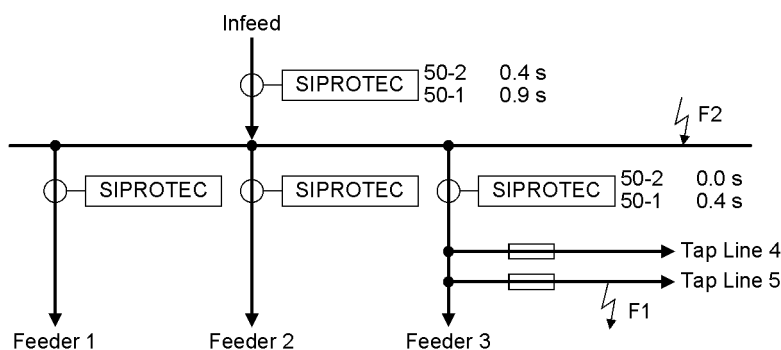

Figure 2-103 Zone sequencing with a fault occurring at Tap Line 5 and at the busbar

2.15.6 Setting Notes

General Settings

The internal automatic reclosure function will only be effective and accessible if address 171 **79 Auto Recl.** is set **Enabled** during configuration. If not required, this function is set to **Disabled**. The function can be turned **ON** or **OFF** under address 7101 **FCT 79**.

If no automatic reclosing is performed on the feeder for which the 7SJ80 is used (e.g. cables, transformers, motors, etc.), the automatic reclosing function is disabled. The automatic reclosing function then has absolutely no effect, that is there will be no associated indications, and binary inputs for the automatic reclosing function are ignored. All parameters of block 71 are inaccessible and not relevant.

Blocking Duration for Manual-CLOSE Detection

Parameter 7103 **BLOCK MC Dur.** defines the reaction of the automatic reclosure function when a manual closing signal is detected. The parameter can be set to specify how long the auto reclosure function will be blocked dynamically in case of an external Manual close-command being detected via binary input (356 „>Manual Close“). If the setting is 0, the automatic reclosure function will not respond to a Manual close signal.

Restraint Time and Dynamic Blocking

The blocking time **TIME RESTRAINT** (address 7105) defines the time that must elapse, after a successful reclosing attempt, before the automatic reclosing function is reset. If a protective function configured for initiation of the automatic reclosure function provokes a new trip before this time elapses, the next reclosing cycle is started in case of multiple reclosures. If no further reclosure is allowed, the last reclosure will be classed as unsuccessful.

In general, a few seconds are sufficient. In areas with frequent thunderstorms or storms, a shorter blocking time may be necessary to avoid feeder lockout due to sequential lightning strikes or flashovers.

A longer restraint time should be chosen if there is no possibility to monitor the circuit breaker (see below) during multiple reclosing (e.g. because of missing auxiliary contacts and information on the circuit breaker ready status). In this case, the restraint time should be longer than the time required for the circuit breaker mechanism to be ready.

If a dynamic blocking of the automatic reclosing function was initiated, then reclosing functions remain blocked until the cause of the blocking has been cleared. The functional description gives further information on this topic, see side title "Dynamic Blocking". The dynamic blocking is associated with the configurable blocking time **SAFETY 79 ready**. Blocking time is usually started by a blocking condition that has picked up.

Circuit Breaker Monitoring

Reclosing after a fault clearance presupposes that the circuit breaker is ready for at least one TRIP-CLOSE-TRIP cycle at the time when the reclosing function is initiated (i.e. at the beginning of a trip command):

The readiness of the circuit breaker is monitored by the device using a binary input „>CB Ready“ (FNo. 2730).

- It is possible to check the status of the circuit breaker before each reclosure or to disable this option (address 7113, **CHECK CB?**):

CHECK CB? = No check, deactivates the circuit breaker check,

CHECK CB? = Chk each cycle, to verify the circuit breaker status before each reclosing command.

Checking the status of the circuit breaker is usually recommended. Should the breaker not provide such a signal, you can disable the circuit breaker check at address 7113 **CHECK CB? (No check)**, as otherwise auto-reclosure would be impossible.

The status monitoring time **CB TIME OUT** can be configured at address 7115 if the circuit breaker check was enabled at address 7113. This time is set slightly higher than the maximum recovery time of the circuit breaker following reclosure. If the circuit breaker is not ready after the time has expired, reclosing is omitted and dynamic blocking is initiated. Automatic reclosure thus is blocked.

The time **Max. DEAD EXT.** at address 7116 serves to monitor the dead time extension. The extension can be initiated by the circuit breaker monitoring time **CB TIME OUT** at address 7115 and by the synchronization function.

The monitoring time **Max. DEAD EXT.** is started after the configured dead time has elapsed.

This time must not be shorter than **CB TIME OUT**. When using the monitoring time **CB TIME OUT**, the time **Max. DEAD EXT.** should be set to a value \geq **CB TIME OUT**.

Since the synchronization is used as synchrocheck, the monitoring time can be set quite short, for example to a few seconds. The synchronization function merely "checks" the synchronism of the power systems. If synchronism is detected, it will be connected instantaneously, otherwise it will not.

But the monitoring time should generally be longer than the maximum duration of the synchronization process (parameter 6112).

The breaker failure monitoring time 7114 **T-Start MONITOR** determines the time between tripping (closing the trip contact) and opening the circuit breaker (checkback of the CB auxiliary contacts or disappearing device pickup if no auxiliary contacts are allocated). This time is started each time a tripping operation takes place. When time has elapsed, the device assumes breaker failure and blocks the automatic reclosure function dynamically.

Action Time

The action time monitors the time between pickup of the device and trip command of a protective function configured as starter while the automatic reclosure function is ready but not yet running. A trip command issued by a protective function configured as starter occurring within the action time will start the automatic reclosing function. If this time differs from the setting value of **T-ACTION** (address 7117), the automatic reclosure function will be blocked dynamically. The trip time of inverse tripping characteristics is considerably determined by the fault location or fault resistance. The action time prevents reclosing in case of far remote or high-resistance faults with long tripping time. Trip commands of protective functions which are not configured as starter do not affect the action time.

Delay of Dead Time Start

The dead time start can be delayed by pickup of the binary input message 2754 „>79 DT St.DeLay“. The maximum time for this can be parameterized under 7118 **T DEAD DELAY**. The binary input message must be deactivated again within this time in order to start the dead time. The exact sequence is described in the functional description at margin heading "Delay of Dead Time Start".

Number of Reclosing Attempts

The number of reclosing attempts can be set separately for the "phase program" (address 7136 # **OF RECL. PH**) and "Ground program" (address 7135 # **OF RECL. GND**). The exact definition of the programs is described in the functional description at margin heading "Reclosing Programs".

Close Command: Direct or via Control

Address 7137 **Cmd.via control** can be set to either generate directly the close command via the automatic reclosing function (setting **Cmd.via control = none**) or have the closing initiated by the control function.

If the automatic reclosure function is to be closed via the control function, the manual closing command has to be suppressed during an automatic reclose command. The example in the section 2.2.11 of a MANUAL CLOSE for commands via the integrated control function has to be extended in this case (see Figure 2-104). The messages 2878 „79 L-N Sequence“ and 2879 „79 L-L Sequence“ indicate that the AR has been started and wants to carry out a reclosure after the dead time. The annunciations set the flipflop and suspend the manual signal until the AR has finished the reclosure attempts. The flipflop is reset via the OR-combination of the annunciations 2784 „79 is NOT ready“, 2785 „79 DynBlock“ and 2862 „79 Successful“. Manual closing is initiated if a CLOSE command comes from the control function.

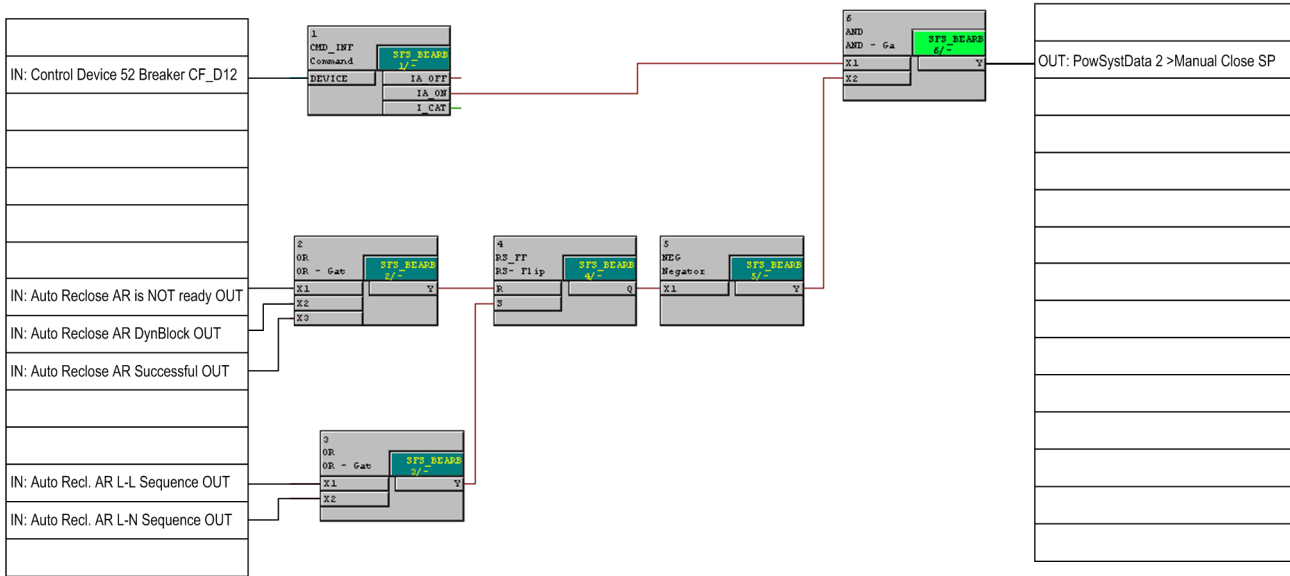

Figure 2-104 CFC logic for Manual Close with automatic reclosing via control

The selection list for parameter 7137 is created dynamically depending on the allocated switchgear components. If one of the switchgear components is selected, usually the circuit breaker „52Breaker“, reclosure is accomplished via control. In this case, the automatic reclosure function does not create a close command but issues a close request. It is forwarded to the control which then takes over the switching. Thus, the properties defined for the switchgear component such as interlocking and command times apply. Hence, it is possible that the close command will not be carried out due to an applying interlocking condition.

If this behavior is not desired, the auto-reclose function can also generate the close command „79 Close“ directly which must be allocated to the associated contact. The CFC chart as in Figure 2-104 is not needed in this case.

Connection to the Internal Synchrocheck

The automatic reclosing function can work together with the internal synchronization function of the device. If this is desired and the manual close function is to be used, the CFC chart illustrated in Figure 2-104 is mandatory since the synchronization function always interacts with the control function. Additionally, synchronization group 1 must be selected via parameter 7138 **Internal SYNC**. This setting defines the synchronization conditions for automatic reclosing. The switchgear objects to be used is defined in the selected synchronization group (usually the circuit breaker „52Breaker“). The switchgear object defined there and the one specified at 7137 **Cmd.via control** must be identical. Synchronous reclosing via the close command „79 Close“ is not possible.

If no interaction with the internal synchronization function is desired, the CFC chart shown in Figure 2-104 is not required and parameter 7138 has to be set to **none**.

Automatic Reclosure with External Synchronism Check

Parameter 7139 **External SYNC** can be set to determine that the automatic reclosure function operates with external synchrocheck. An external synchronization is possible if the parameter is set to **YES** and the device is connected to the external synchronization check via indication 2865 „79 Sync .Request“ and the binary input „>Sync .release“.

Note: The automatic reclosure function cannot be connected to the internal and external synchrocheck at the same time !

Initiation and Blocking of Automatic Reclosure by Protective Elements (configuration)

Addresses 7150 through 7164, 7166 through 7169 can be set to specify which protection functions work together with the automatic reclosing function. Together they constitute the wiring between protection elements and automatic reclosing function. Each address designates a protection function together with its ANSI synonym, for example **50-2** for the 50-2 Element of the non-directional time overcurrent protection (address 7152).

The setting options have the following meaning:

- **Starts 79** The protective element initiates the automatic reclosure via its trip command;
- **No influence** the protective element does not start the automatic reclosure, it may however be initiated by other functions;
- **Stops 79** the protective element blocks the automatic reclosure, it cannot be started by other functions; a dynamic blocking is initiated.

Dead Times (1st AR)

Addresses 7127 and 7128 are used to determine the duration of the dead times of the 1st cycle. The time defined by this parameter is started when the circuit breaker opens (if auxiliary contacts are allocated) or when the pickup drops out following the trip command of a starter. Dead time before first automatic reclosure for reclosing program "Phase" is set in address 7127 **DEADTIME 1: PH**, for reclosing program "Ground" in address 7128 **DEADTIME 1: G**. The exact definition of the programs is described in the functional description at margin heading "Reclosing Programs". The length of the dead time should relate to the type of application. With longer lines, they should be long enough to make sure that the fault arc disappears and that the air surrounding it is de-ionized and auto-reclosure can successfully take place (usually 0.9 s to 1.5 s). For lines supplied by more than one side, mostly system stability has priority. Since the de-energized line cannot transfer synchronizing energy, only short dead times are allowed. Standard values are 0.3 s to 0.6 s. In radial systems, longer dead times are allowed.

Cyclic Control of the Protection Functions by the Automatic Reclosing Function

The addresses 7200 through 7211, 7248, 7249, 7256 and 7257 allow the different protection functions to be controlled cyclically by the AR. This enables protection elements to be blocked selectively, set to operate instantaneously or according to the configured delay times. The following settings are available:

The following options are available:

- **Set value $T=T$** The protection element is delayed as configured, that is the automatic reclosing function does not affect the Element;
- **instant. $T=0$** The protection element becomes instantaneous if the automatic reclosing function is ready to perform the mentioned cycle;
- **blocked $T=\infty$** The protection element is blocked when the automatic reclosing function reaches the cycle defined in the parameter. The element picks up, however, the expiry of the element is blocked by this setting.

Dead Times (2nd to 4th reclosing attempt)

If more than one reclosing cycle was set, you can now configure the individual reclosing settings for the 2nd to 4th cycle. The same options are available as for the first cycle.

For the 2nd cycle:

Address 7129	DEADTIME 2: PH	Dead time for the 2nd reclosing attempt, phase
Address 7130	DEADTIME 2: G	Dead time for the 2nd reclosing attempt Ground
Addresses 7212 through 7223, 7250, 7251, 7258, 7259		Cyclic control of the various protection functions before the 2nd reclosing attempt

For the 3rd cycle:

Address 7131	DEADTIME 3: PH	Dead time for the 3rd reclosing attempt, phase
Address 7132	DEADTIME 3: G	Dead time for the 3rd reclosing attempt Ground
Addresses 7224 through 7235, 7252, 7253, 7260, 7261		Cyclic control of the various protection functions before the 3rd reclosing attempt

For the 4th cycle:

Address 7133	DEADTIME 4: PH	Dead time for the 4th reclosing attempt, phase
Address 7134	DEADTIME 4: G	Dead time for the 4th reclosing attempt Ground
Addresses 7236 through 7247, 7254, 7255, 7262, 7263		Cyclic control of the various protection functions before the 4th reclosing attempt

Fifth to Ninth Reclosing Attempt

If more than four cycles are configured, the dead times set for the fourth cycle also apply to the fifth to ninth cycle.

Blocking Three-Phase Faults

Regardless of which reclosing program is executed, automatic reclosing can be blocked for trips following three-phase faults (address 7165 **3Po1.PICKUP BLK**). The pickup of all three phases for a overcurrent element is the criterion required.

Blocking of Automatic Rreclosure via Internal Control

The automatic reclosure function can be blocked, if control commands are issued via the integrated control function of the device. The information must be routed via CFC (interlocking task-level) using the CMD_Information function block (see the following figure).

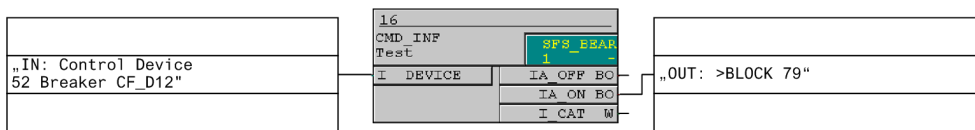

Figure 2-105 Blocking of the automatic reclose function using the internal control function

Zone Sequencing / Fuse Saving Scheme

Not available for models 7SJ8***-**A**-

At address 7140 **ZONE SEQ.COORD.**, the zone sequencing feature can be turned **ON** or **OFF**.

If multiple reclosing operations are performed and the zone sequencing function is deactivated, only those reclosing cycles are counted which the device has conducted after a trip command. If the zone sequencing function is switched on, an additional sequence counter also counts such automatic reclosures which (in radial systems) are carried out by relays connected on load side. This presupposes that the pickup of the 50-1/50N-1 elements drops out without a trip command being issued by a protection function starting the automatic reclosing function. The parameters at addresses 7200 through 7263 (see paragraphs below at "Start and Blocking of Automatic Reclosing by Protection Functions" and "Controlling Directional/Non-Directional Overcurrent Pro-

tection Elements via Cold Load Pickup") can thus be set to determine which protection elements are active or blocked during what dead time cycles (for multiple reclosing attempts carried out by relays on the load side).

In the example shown in Figure "Zone sequencing with a fault occurring at Tap Line 5 and the busbar" (see Figure 2-103) in the functional description, the zone sequencing was applied in the bus relay. Furthermore, as from the second automatic reclosure, the 50-2 elements (also applicable to the 50-3 elements) must be blocked, i.e. address 7214 **bef. 2.Cy:50-2** must be set to **blocked T=∞**. The zone sequencing of the feeder relays is switched off but the 50-2 elements must also be blocked after the second reclosing attempt. Moreover, it must be ensured that the 50-2 elements start the automatic reclosing function: Set address 7152 **50-2** to **Starts 79**.

All settings of the 50-2 and 50-3 elements apply analogously to the 50N-2 and 50N-3 elements.

Controlling Directional / Non-Directional Overcurrent Protection Elements via Dynamic Cold Load Pickup

The dynamic cold load pickup function provides a further alternative to control the protection via the automatic reclosing function (see also Section 2.4). This function contains the parameter 1702 **Start Condition** It determines the starting conditions for the increased setting values of current and time of the dynamic cold load pickup that must apply for directional and non-directional overcurrent protection.

If parameter 1702 **Start Condition** is set to **79 ready**, the directional and non-directional overcurrent protection always use the increased setting values if the automatic reclosing function is ready. The automatic reclosure function provides the signal **79 ready** for controlling the dynamic cold load pickup. The signal **79 ready** is always active if the automatic reclosure function is available, active, unblocked and ready for another cycle. Control via the dynamic cold load pickup function is non-cyclic.

Since control via dynamic cold load pickup and cyclic control via automatic reclosure function can run simultaneously, the directional and non-directional overcurrent protection must coordinate the input values of the two interfaces. In this context, the cyclic auto-reclosing control has the priority and thus overwrites the release of the dynamic cold load pickup function.

If the protective elements are controlled via the automatic reclosure function, changing the control variables (e.g. by blocking) has no effect on elements that are already running. The elements in question are continued.

Note Regarding Settings List for Automatic Reclosure Function

The setting options of address 7137 **Cmd.via control** are generated dynamically according to the current configuration.

2.15.7 Settings

Addr.	Parameter	Setting Options	Default Setting	Comments
7101	FCT 79	OFF ON	OFF	79 Auto-Reclose Function
7103	BLOCK MC Dur.	0.50 .. 320.00 sec; 0	1.00 sec	AR blocking duration after manual close
7105	TIME RESTRAINT	0.50 .. 320.00 sec	3.00 sec	79 Auto Reclosing reset time
7108	SAFETY 79 ready	0.01 .. 320.00 sec	0.50 sec	Safety Time until 79 is ready
7113	CHECK CB?	No check Chk each cycle	No check	Check circuit breaker before AR?
7114	T-Start MONITOR	0.01 .. 320.00 sec; ∞	0.50 sec	AR start-signal monitoring time
7115	CB TIME OUT	0.10 .. 320.00 sec	3.00 sec	Circuit Breaker (CB) Supervision Time

Addr.	Parameter	Setting Options	Default Setting	Comments
7116	Max. DEAD EXT.	0.50 .. 1800.00 sec; ∞	100.00 sec	Maximum dead time extension
7117	T-ACTION	0.01 .. 320.00 sec; ∞	∞ sec	Action time
7118	T DEAD DELAY	0.0 .. 1800.0 sec; ∞	1.0 sec	Maximum Time Delay of Dead-Time Start
7127	DEADTIME 1: PH	0.01 .. 320.00 sec	0.50 sec	Dead Time 1: Phase Fault
7128	DEADTIME 1: G	0.01 .. 320.00 sec	0.50 sec	Dead Time 1: Ground Fault
7129	DEADTIME 2: PH	0.01 .. 320.00 sec	0.50 sec	Dead Time 2: Phase Fault
7130	DEADTIME 2: G	0.01 .. 320.00 sec	0.50 sec	Dead Time 2: Ground Fault
7131	DEADTIME 3: PH	0.01 .. 320.00 sec	0.50 sec	Dead Time 3: Phase Fault
7132	DEADTIME 3: G	0.01 .. 320.00 sec	0.50 sec	Dead Time 3: Ground Fault
7133	DEADTIME 4: PH	0.01 .. 320.00 sec	0.50 sec	Dead Time 4: Phase Fault
7134	DEADTIME 4: G	0.01 .. 320.00 sec	0.50 sec	Dead Time 4: Ground Fault
7135	# OF RECL. GND	0 .. 9	1	Number of Reclosing Cycles Ground
7136	# OF RECL. PH	0 .. 9	1	Number of Reclosing Cycles Phase
7137	Cmd.via control	(Setting options depend on configuration)	None	Close command via control device
7138	Internal SYNC	(Setting options depend on configuration)	None	Internal 25 synchronisation
7139	External SYNC	YES NO	NO	External 25 synchronisation
7140	ZONE SEQ.COORD.	OFF ON	OFF	ZSC - Zone sequence coordination
7150	50-1	No influence Starts 79 Stops 79	No influence	50-1
7151	50N-1	No influence Starts 79 Stops 79	No influence	50N-1
7152	50-2	No influence Starts 79 Stops 79	No influence	50-2
7153	50N-2	No influence Starts 79 Stops 79	No influence	50N-2
7154	51	No influence Starts 79 Stops 79	No influence	51
7155	51N	No influence Starts 79 Stops 79	No influence	51N
7156	67-1	No influence Starts 79 Stops 79	No influence	67-1

Addr.	Parameter	Setting Options	Default Setting	Comments
7157	67N-1	No influence Starts 79 Stops 79	No influence	67N-1
7158	67-2	No influence Starts 79 Stops 79	No influence	67-2
7159	67N-2	No influence Starts 79 Stops 79	No influence	67N-2
7160	67 TOC	No influence Starts 79 Stops 79	No influence	67 TOC
7161	67N TOC	No influence Starts 79 Stops 79	No influence	67N TOC
7162	sens Ground Fit	No influence Starts 79 Stops 79	No influence	(Sensitive) Ground Fault
7163	46	No influence Starts 79 Stops 79	No influence	46
7164	BINARY INPUT	No influence Starts 79 Stops 79	No influence	Binary Input
7165	3Pol.PICKUP BLK	YES NO	NO	3 Pole Pickup blocks 79
7166	50-3	No influence Starts 79 Stops 79	No influence	50-3
7167	50N-3	No influence Starts 79 Stops 79	No influence	50N-3
7168	67-3	No influence Starts 79 Stops 79	No influence	67-3
7169	67N-3	No influence Starts 79 Stops 79	No influence	67N-3
7200	bef.1.Cy:50-1	Set value T=T instant. T=0 blocked T= ∞	Set value T=T	before 1. Cycle: 50-1
7201	bef.1.Cy:50N-1	Set value T=T instant. T=0 blocked T= ∞	Set value T=T	before 1. Cycle: 50N-1
7202	bef.1.Cy:50-2	Set value T=T instant. T=0 blocked T= ∞	Set value T=T	before 1. Cycle: 50-2
7203	bef.1.Cy:50N-2	Set value T=T instant. T=0 blocked T= ∞	Set value T=T	before 1. Cycle: 50N-2

Addr.	Parameter	Setting Options	Default Setting	Comments
7204	bef.1.Cy:51	Set value T=T instant. T=0 blocked T=∞	Set value T=T	before 1. Cycle: 51
7205	bef.1.Cy:51N	Set value T=T instant. T=0 blocked T=∞	Set value T=T	before 1. Cycle: 51N
7206	bef.1.Cy:67-1	Set value T=T instant. T=0 blocked T=∞	Set value T=T	before 1. Cycle: 67-1
7207	bef.1.Cy:67N-1	Set value T=T instant. T=0 blocked T=∞	Set value T=T	before 1. Cycle: 67N-1
7208	bef.1.Cy:67-2	Set value T=T instant. T=0 blocked T=∞	Set value T=T	before 1. Cycle: 67-2
7209	bef.1.Cy:67N-2	Set value T=T instant. T=0 blocked T=∞	Set value T=T	before 1. Cycle: 67N-2
7210	bef.1.Cy:67 TOC	Set value T=T instant. T=0 blocked T=∞	Set value T=T	before 1. Cycle: 67 TOC
7211	bef.1.Cy:67NTOC	Set value T=T instant. T=0 blocked T=∞	Set value T=T	before 1. Cycle: 67N TOC
7212	bef.2.Cy:50-1	Set value T=T instant. T=0 blocked T=∞	Set value T=T	before 2. Cycle: 50-1
7213	bef.2.Cy:50N-1	Set value T=T instant. T=0 blocked T=∞	Set value T=T	before 2. Cycle: 50N-1
7214	bef.2.Cy:50-2	Set value T=T instant. T=0 blocked T=∞	Set value T=T	before 2. Cycle: 50-2
7215	bef.2.Cy:50N-2	Set value T=T instant. T=0 blocked T=∞	Set value T=T	before 2. Cycle: 50N-2
7216	bef.2.Cy:51	Set value T=T instant. T=0 blocked T=∞	Set value T=T	before 2. Cycle: 51
7217	bef.2.Cy:51N	Set value T=T instant. T=0 blocked T=∞	Set value T=T	before 2. Cycle: 51N
7218	bef.2.Cy:67-1	Set value T=T instant. T=0 blocked T=∞	Set value T=T	before 2. Cycle: 67-1
7219	bef.2.Cy:67N-1	Set value T=T instant. T=0 blocked T=∞	Set value T=T	before 2. Cycle: 67N-1

Addr.	Parameter	Setting Options	Default Setting	Comments
7220	bef.2.Cy:67-2	Set value T=T instant. T=0 blocked T= ∞	Set value T=T	before 2. Cycle: 67-2
7221	bef.2.Cy:67N-2	Set value T=T instant. T=0 blocked T= ∞	Set value T=T	before 2. Cycle: 67N-2
7222	bef.2.Cy:67 TOC	Set value T=T instant. T=0 blocked T= ∞	Set value T=T	before 2. Cycle: 67 TOC
7223	bef.2.Cy:67NTOC	Set value T=T instant. T=0 blocked T= ∞	Set value T=T	before 2. Cycle: 67N TOC
7224	bef.3.Cy:50-1	Set value T=T instant. T=0 blocked T= ∞	Set value T=T	before 3. Cycle: 50-1
7225	bef.3.Cy:50N-1	Set value T=T instant. T=0 blocked T= ∞	Set value T=T	before 3. Cycle: 50N-1
7226	bef.3.Cy:50-2	Set value T=T instant. T=0 blocked T= ∞	Set value T=T	before 3. Cycle: 50-2
7227	bef.3.Cy:50N-2	Set value T=T instant. T=0 blocked T= ∞	Set value T=T	before 3. Cycle: 50N-2
7228	bef.3.Cy:51	Set value T=T instant. T=0 blocked T= ∞	Set value T=T	before 3. Cycle: 51
7229	bef.3.Cy:51N	Set value T=T instant. T=0 blocked T= ∞	Set value T=T	before 3. Cycle: 51N
7230	bef.3.Cy:67-1	Set value T=T instant. T=0 blocked T= ∞	Set value T=T	before 3. Cycle: 67-1
7231	bef.3.Cy:67N-1	Set value T=T instant. T=0 blocked T= ∞	Set value T=T	before 3. Cycle: 67N-1
7232	bef.3.Cy:67-2	Set value T=T instant. T=0 blocked T= ∞	Set value T=T	before 3. Cycle: 67-2
7233	bef.3.Cy:67N-2	Set value T=T instant. T=0 blocked T= ∞	Set value T=T	before 3. Cycle: 67N-2
7234	bef.3.Cy:67 TOC	Set value T=T instant. T=0 blocked T= ∞	Set value T=T	before 3. Cycle: 67 TOC
7235	bef.3.Cy:67NTOC	Set value T=T instant. T=0 blocked T= ∞	Set value T=T	before 3. Cycle: 67N TOC

Addr.	Parameter	Setting Options	Default Setting	Comments
7236	bef.4.Cy:50-1	Set value T=T instant. T=0 blocked T=∞	Set value T=T	before 4. Cycle: 50-1
7237	bef.4.Cy:50N-1	Set value T=T instant. T=0 blocked T=∞	Set value T=T	before 4. Cycle: 50N-1
7238	bef.4.Cy:50-2	Set value T=T instant. T=0 blocked T=∞	Set value T=T	before 4. Cycle: 50-2
7239	bef.4.Cy:50N-2	Set value T=T instant. T=0 blocked T=∞	Set value T=T	before 4. Cycle: 50N-2
7240	bef.4.Cy:51	Set value T=T instant. T=0 blocked T=∞	Set value T=T	before 4. Cycle: 51
7241	bef.4.Cy:51N	Set value T=T instant. T=0 blocked T=∞	Set value T=T	before 4. Cycle: 51N
7242	bef.4.Cy:67-1	Set value T=T instant. T=0 blocked T=∞	Set value T=T	before 4. Cycle: 67-1
7243	bef.4.Cy:67N-1	Set value T=T instant. T=0 blocked T=∞	Set value T=T	before 4. Cycle: 67N-1
7244	bef.4.Cy:67-2	Set value T=T instant. T=0 blocked T=∞	Set value T=T	before 4. Cycle: 67-2
7245	bef.4.Cy:67N-2	Set value T=T instant. T=0 blocked T=∞	Set value T=T	before 4. Cycle: 67N-2
7246	bef.4.Cy:67 TOC	Set value T=T instant. T=0 blocked T=∞	Set value T=T	before 4. Cycle: 67 TOC
7247	bef.4.Cy:67NTOC	Set value T=T instant. T=0 blocked T=∞	Set value T=T	before 4. Cycle: 67N TOC
7248	bef.1.Cy:50-3	Set value T=T instant. T=0 blocked T=∞	Set value T=T	before 1. Cycle: 50-3
7249	bef.1.Cy:50N-3	Set value T=T instant. T=0 blocked T=∞	Set value T=T	before 1. Cycle: 50N-3
7250	bef.2.Cy:50-3	Set value T=T instant. T=0 blocked T=∞	Set value T=T	before 2. Cycle: 50-3
7251	bef.2.Cy:50N-3	Set value T=T instant. T=0 blocked T=∞	Set value T=T	before 2. Cycle: 50N-3

Addr.	Parameter	Setting Options	Default Setting	Comments
7252	bef.3.Cy:50-3	Set value T=T instant. T=0 blocked T= ∞	Set value T=T	before 3. Cycle: 50-3
7253	bef.3.Cy:50N-3	Set value T=T instant. T=0 blocked T= ∞	Set value T=T	before 3. Cycle: 50N-3
7254	bef.4.Cy:50-3	Set value T=T instant. T=0 blocked T= ∞	Set value T=T	before 4. Cycle: 50-3
7255	bef.4.Cy:50N-3	Set value T=T instant. T=0 blocked T= ∞	Set value T=T	before 4. Cycle: 50N-3
7256	bef.1.Cy:67-3	Set value T=T instant. T=0 blocked T= ∞	Set value T=T	before 1. Cycle: 67-3
7257	bef.1.Cy:67N-3	Set value T=T instant. T=0 blocked T= ∞	Set value T=T	before 1. Cycle: IE>>> directional
7258	bef.2.Cy:67-3	Set value T=T instant. T=0 blocked T= ∞	Set value T=T	before 2. Cycle: 67-3
7259	bef.2.Cy:67N-3	Set value T=T instant. T=0 blocked T= ∞	Set value T=T	before 2. Cycle: IE>>> directional
7260	bef.3.Cy:67-3	Set value T=T instant. T=0 blocked T= ∞	Set value T=T	before 3. Cycle: 67-3
7261	bef.3.Cy:67N-3	Set value T=T instant. T=0 blocked T= ∞	Set value T=T	before 3. Cycle: IE>>> directional
7262	bef.4.Cy:67-3	Set value T=T instant. T=0 blocked T= ∞	Set value T=T	before 4. Cycle: 67-3
7263	bef.4.Cy:67N-3	Set value T=T instant. T=0 blocked T= ∞	Set value T=T	before 4. Cycle: 67N-3

2.15.8 Information List

No.	Information	Type of Information	Comments
127	79 ON/OFF	IntSP	79 ON/OFF (via system port)
2701	>79 ON	SP	>79 ON
2702	>79 OFF	SP	>79 OFF
2703	>BLOCK 79	SP	>BLOCK 79
2711	>79 Start	SP	>79 External start of internal A/R
2715	>Start 79 Gnd	SP	>Start 79 Ground program
2716	>Start 79 Ph	SP	>Start 79 Phase program

No.	Information	Type of Information	Comments
2722	>ZSC ON	SP	>Switch zone sequence coordination ON
2723	>ZSC OFF	SP	>Switch zone sequence coordination OFF
2730	>CB Ready	SP	>Circuit breaker READY for reclosing
2731	>Sync.release	SP	>79: Sync. release from ext. sync.-check
2753	79 DT delay ex.	OUT	79: Max. Dead Time Start Delay expired
2754	>79 DT St.Delay	SP	>79: Dead Time Start Delay
2781	79 OFF	OUT	79 Auto recloser is switched OFF
2782	79 ON	IntSP	79 Auto recloser is switched ON
2784	79 is NOT ready	OUT	79 Auto recloser is NOT ready
2785	79 DynBlock	OUT	79 - Auto-reclose is dynamically BLOCKED
2788	79 T-CBreadyExp	OUT	79: CB ready monitoring window expired
2801	79 in progress	OUT	79 - in progress
2808	79 BLK: CB open	OUT	79: CB open with no trip
2809	79 T-Start Exp	OUT	79: Start-signal monitoring time expired
2810	79 TdeadMax Exp	OUT	79: Maximum dead time expired
2823	79 no starter	OUT	79: no starter configured
2824	79 no cycle	OUT	79: no cycle configured
2827	79 BLK by trip	OUT	79: blocking due to trip
2828	79 BLK:3ph p.u.	OUT	79: blocking due to 3-phase pickup
2829	79 Tact expired	OUT	79: action time expired before trip
2830	79 Max. No. Cyc	OUT	79: max. no. of cycles exceeded
2844	79 1stCyc. run.	OUT	79 1st cycle running
2845	79 2ndCyc. run.	OUT	79 2nd cycle running
2846	79 3rdCyc. run.	OUT	79 3rd cycle running
2847	79 4thCyc. run.	OUT	79 4th or higher cycle running
2851	79 Close	OUT	79 - Close command
2862	79 Successful	OUT	79 - cycle successful
2863	79 Lockout	OUT	79 - Lockout
2865	79 Sync.Request	OUT	79: Synchro-check request
2878	79 L-N Sequence	OUT	79-A/R single phase reclosing sequence
2879	79 L-L Sequence	OUT	79-A/R multi-phase reclosing sequence
2883	ZSC active	OUT	Zone Sequencing is active
2884	ZSC ON	OUT	Zone sequence coordination switched ON
2885	ZSC OFF	OUT	Zone sequence coordination switched OFF
2889	79 1.CycZoneRel	OUT	79 1st cycle zone extension release
2890	79 2.CycZoneRel	OUT	79 2nd cycle zone extension release
2891	79 3.CycZoneRel	OUT	79 3rd cycle zone extension release
2892	79 4.CycZoneRel	OUT	79 4th cycle zone extension release
2899	79 CloseRequest	OUT	79: Close request to Control Function

2.16 Fault Locator

The measurement of the distance to a short-circuit fault is a supplement to the protection functions. Power transmission within the system can be increased when the fault is located and cleared faster.

2.16.1 Description

General

The fault locator is a stand-alone and independent function which uses the line and power system parameters set in other functions. In the event of a fault, it is addressed by the protection functions provided in the 7SJ80 device.

The protected object can e.g. be an inhomogeneous line. For calculation purposes, the line can be divided into different sections, for example, a short cable followed by an overhead line. In such protected objects, you can configure each section individually. Without this information, the fault locator uses the general line data (see Section 2.1.6.2).

The fault locator also calculates double ground faults with different base points, reverse faults and faults that are located behind the configured sections. For faults that are not located within the configured sections, the fault locator uses the general line data.

The fault locator can be triggered by the trip command of the non-directional or directional time overcurrent protection, or by each fault detection. In the latter case, fault location calculations is even possible if another protection relay cleared the fault. Additionally, the fault location can be initiated via a binary input. However, it is a prerequisite that pickup of the time overcurrent protection is performed at the same time (directional or non-directional).



Note

Depending on the type of voltage connection (see Table 2-1) and in case of capacitive voltage measurement, the fault locator is disabled.

Fault Location Determination

The measurement principle of the fault locator is based on the calculation of impedances.

Sampled value pairs of short-circuit current and short-circuit voltage are stored in a buffer (at a sampling rate of 1/20 cycle) shortly after the trip command. To date, even with very fast circuit breakers, no errors in the measured values have occurred during the shutdown procedure. Measured value filtering and the number of impedance calculations are adjusted automatically to the number of stable measured value pairs in the determined data window. If no sufficient data windows with reliable values could be determined for fault location, message „Flt.Loc.invalid“ is issued.

The fault locator evaluates the short-circuit loops and uses the loops with the lowest fault impedance (see margin heading „Loop Selection“).

Loop Selection

Using the pickup of the time overcurrent protection (directional or non-directional), the valid measurement loops for the calculation of fault impedance are selected.

Table 2-17 shows the assignment of the evaluated loops to the possible pickup scenarios of the protection elements.

Table 2-17 Assignment of Pickup - Evaluated Loops

Pickup by				fault type	measured loop	signaled loop
A	B	C	N			
x				A	A-N	A-N
	x			B	B-N	B-N
		x		C	C-N	C-N
			x	N	A-N, B-N, C-N	lowest impedance
x			x	A-N	A-N	A-N
	x		x	B-N	B-N	B-N
		x	x	C-N	C-N	C-N
x	x			A-B	A-B	A-B
x		x		A-C	A-C	A-C
	x	x		B-C	B-C	B-C
x	x		x	A-B-N	A-B, A-N, B-N	Lowest impedance
x		x	x	A-C-N	C-A, A-N, B-N	Lowest impedance
	x	x	x	B-C-N	B-C, B-N, C-N	Lowest impedance
x	x	x		A-B-C	A-B, B-C, C-A	lowest impedance
x	x	x	x	A-B-C-N	A-B, B-C, C-A, A-N, B-N, C-N	lowest impedance

Output of Fault Location

The following information is output as result of the fault location:

- the short-circuit loop from which the fault reactance was determined,
- the fault reactance X in Ω primary and Ω secondary,
- the fault resistance R in Ω primary and Ω secondary,
- the distance to fault d in kilometers or miles of the line proportional to the reactance, converted on the basis of the set line reactance per unit line length,
- the distance to fault d in % of the line length, calculated on the basis of the set reactance per unit length and the set line length.

Line Sections

The line type is determined by the line section settings. If, for instance, the line includes a cable and an overhead line, two different sections must be configured. The system can distinguish between up to three different line types. When configuring this line data, please note that the different tabs for setting the line sections will only be displayed if more than one line section has been configured under the functional scope (address 181). The parameters for a line section are entered in the Setting tab .

2.16.2 Setting Notes

General

The fault location is only enabled if address 180 was set to **Enabled** during configuration of the function extent.

Under address 181 **L-sections FL** the number of line section must be selected, which is required for the accurate description of the line. If the number is set to **2 Sections** or **3 Sections**, further setting sheets appear in the **Power System Data 2** in DIGSI. Default setting is **1 Section**.

Line Data

To calculate the fault distance in kilometers or miles, the device needs the per distance reactance of the line in Ω /kilometer or Ω /mile. Furthermore, the line length in km or miles, the angle of the line impedance, and resistance and reactance ratios are required. These parameters have already been set in the **Power System Data 2** for a maximum of 3 line sections (see Section 2.1.6.2 under „Ground Impedance Ratios“ and „Reactance per Unit Length“).

Initiation of Measurement

Normally the fault location calculation is started when a directional or non-directional time overcurrent protection initiates a trip signal (address 8001 **START = TRIP**). However, it may also be initiated when pickup drops out (address 8001 **START = Pickup**), e.g. when another protection element clears the fault. Irrespective of this fact, calculation of the fault location can be triggered externally via a binary input. (FNo. 1106 „>Start Flt. Loc“) provided the device has picked up.

2.16.3 Settings

Addr.	Parameter	Setting Options	Default Setting	Comments
8001	START	Pickup TRIP	Pickup	Start fault locator with

2.16.4 Information List

No.	Information	Type of Information	Comments
1106	>Start Flt. Loc	SP	>Start Fault Locator
1114	Rpri =	VI	Flt Locator: primary RESISTANCE
1115	Xpri =	VI	Flt Locator: primary REACTANCE
1117	Rsec =	VI	Flt Locator: secondary RESISTANCE
1118	Xsec =	VI	Flt Locator: secondary REACTANCE
1119	dist =	VI	Flt Locator: Distance to fault
1120	d[%] =	VI	Flt Locator: Distance [%] to fault
1122	dist =	VI	Flt Locator: Distance to fault
1123	FL Loop AG	OUT	Fault Locator Loop AG
1124	FL Loop BG	OUT	Fault Locator Loop BG
1125	FL Loop CG	OUT	Fault Locator Loop CG
1126	FL Loop AB	OUT	Fault Locator Loop AB
1127	FL Loop BC	OUT	Fault Locator Loop BC
1128	FL Loop CA	OUT	Fault Locator Loop CA
1132	Flt.Loc.invalid	OUT	Fault location invalid

2.17 Breaker Failure Protection 50BF

The breaker failure protection function monitors proper tripping of the relevant circuit breaker.

2.17.1 Description

General

If after a programmable time delay, the circuit breaker has not opened, breaker failure protection issues a trip signal to isolate the failure breaker by tripping other surrounding backup circuit breaker (see example in the figure below).

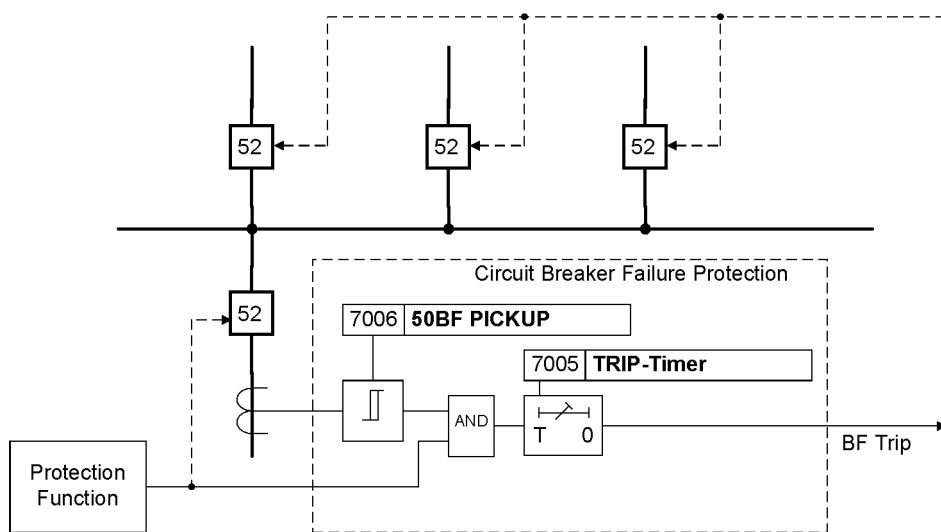

Figure 2-106 Function principle of the breaker failure protection

Initiation

The breaker failure protection function can be initiated by two different sources:

- Trip signals of internal protective functions of the 7SJ80,
- external trip signals via binary inputs („>50BF ext SRC“).

For each of the two sources, a unique pickup message is generated, a unique time delay is initiated, and a unique trip signal is generated. The setting values of current threshold and delay time apply to both sources.

Criteria

There are two criteria for breaker failure detection:

- Check whether the current flow has effectively disappeared after a tripping command was issued,
- Evaluate the circuit breaker's auxiliary contacts.

The criteria used to determine if the circuit breaker has operated are selectable and also depend on the protection function that initiated the breaker failure function. On tripping without fault current, e.g. via voltage protection, the current below the threshold **50BF PICKUP** is not a reliable indication of the proper functioning of the circuit breaker. In such cases, pickup exclusively depends on the auxiliary contact criterion. In protection functions based on the measurement of currents (including all short-circuit protection functions), the current flow is a preferential criterion, i.e. it is given priority, as opposed to the auxiliary contacts. If current flows above

the set threshold or thresholds (**enabled w/ 3I0>**) are detected, the breaker failure protection trips even if the auxiliary criterion indicates „Breaker Open“.

Monitoring of the Current Flow

Address 170 **50BF** can be set in such a way that either the current criterion can already be met by a single phase current (setting **Enabled**) or that another current is taken into consideration in order to check the plausibility (setting **enabled w/ 3I0>**), see Figure .

The currents are filtered through numerical filters to evaluate only the fundamental harmonic. They are monitored and compared to the set threshold values. Besides the three phase currents, two additional currents are provided to enable a plausibility check. Separate threshold values can be used for this plausibility check if this is configured accordingly. To detect ground faults more quickly, the threshold value for the ground current can also be used for checking the plausibility of the phase currents. This function is activated via binary input „>50BFactiv.3I0>“ (see Figure 2-109).

The ground current I_N ($3 \cdot I_0$) is preferably used as plausibility current. Via the parameters 613 you decide whether the measured (**I_{gnd} (measured)**) or the calculated (**3I0 (calcul.)**) values are to be used. In case of system faults not involving ground currents, no increased ground currents/residual currents are flowing, and therefore the calculated triple negative sequence current $3 \cdot I_2$ or a second phase current is used as plausibility current.

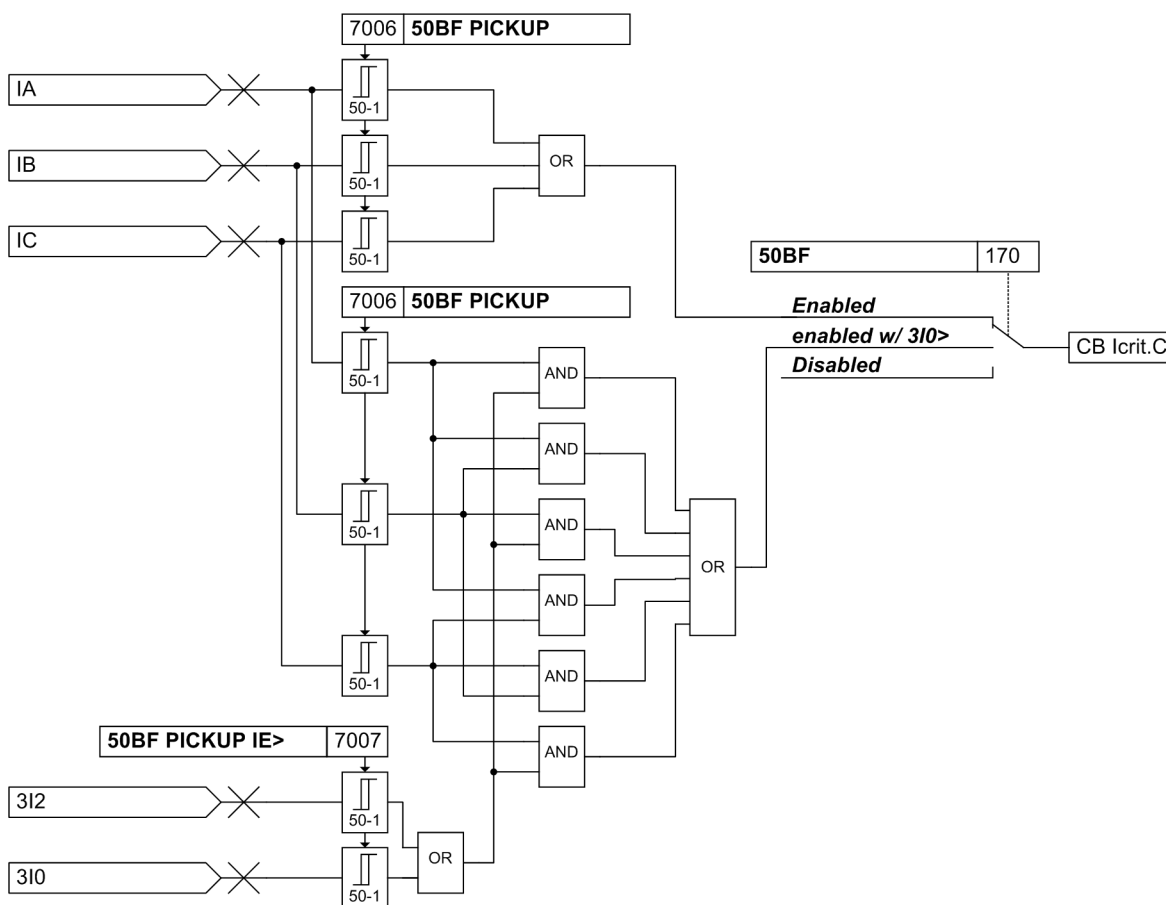

Figure 2-107 Monitoring of the current flow

Monitoring of the Circuit Breaker Auxiliary Contacts

Evaluation of the circuit breaker's auxiliary contacts depends on the type of contacts, and how they are connected to the binary inputs:

- the auxiliary contacts for circuit breaker "open" (4602 „>52 - b“) and "closed" (4601 „>52 - a“) are configured,
- only the auxiliary contact for circuit breaker "open" is configured(4602 „>52 - b“),
- only the auxiliary contact for circuit breaker "closed" is configured (4601 „>52 - a“),
- none of the two auxiliary contacts is configured.

Feedback information of the auxiliary status of the circuit breaker is evaluated, depending on the allocation of binary inputs and auxiliary contacts. After a trip command has been issued it is the aim to detect — if possible — by means of the feedback of the circuit breaker's auxiliary contacts whether the breaker is open or in intermediate position. If valid, this information can be used for a proper initiation of the breaker failure protection function.

The logic diagram illustrates the monitoring of the circuit breaker's auxiliary contacts.

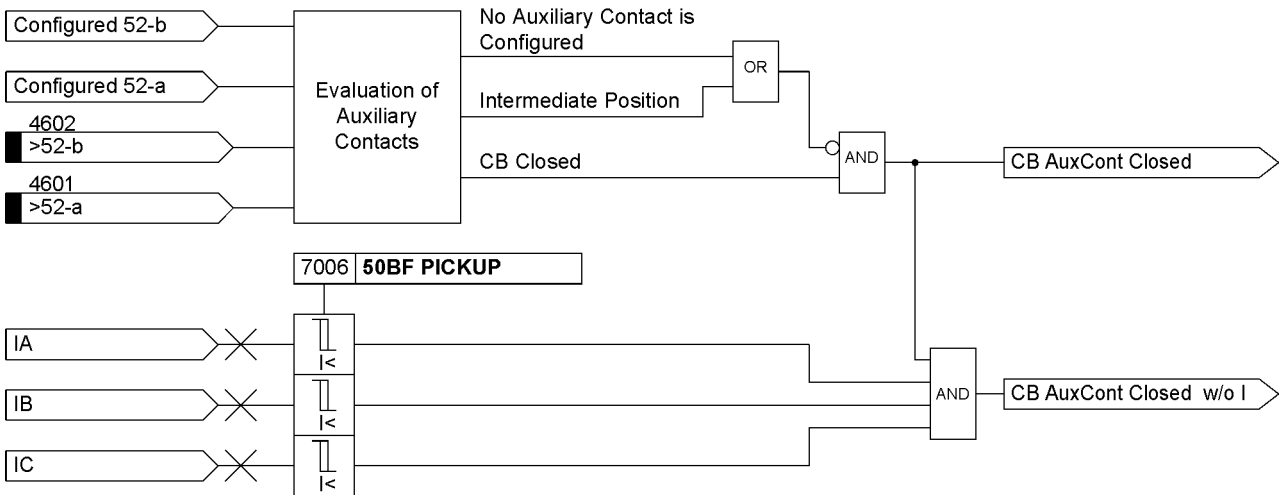

Figure 2-108 Logic diagram for breaker failure protection, monitoring of the circuit-breaker auxiliary contacts

Logic

If breaker failure protection is initiated, an alarm message is generated and a settable delay time is started. If once the time delay has elapsed, criteria for a pickup are still met, a trip signal is issued to a superordinate circuit breaker. Therefore, the trip signal issued by the breaker failure protection is configured to one of the output relays.

The following figure shows the logic diagram for the breaker failure protection function. The entire breaker failure protection function may be turned on or off, or it can be blocked dynamically via binary inputs.

If the criteria that led to the pickup are no longer met when the time delay has elapsed, such pickup thus drops out and no trip signal is issued by the breaker failure protection function.

To protect against nuisance tripping due to excessive contact bounce, a stabilization of the binary inputs for external trip signals takes place. This external signal must be present during the entire period of the delay time, otherwise the timer is reset and no trip signal is issued.

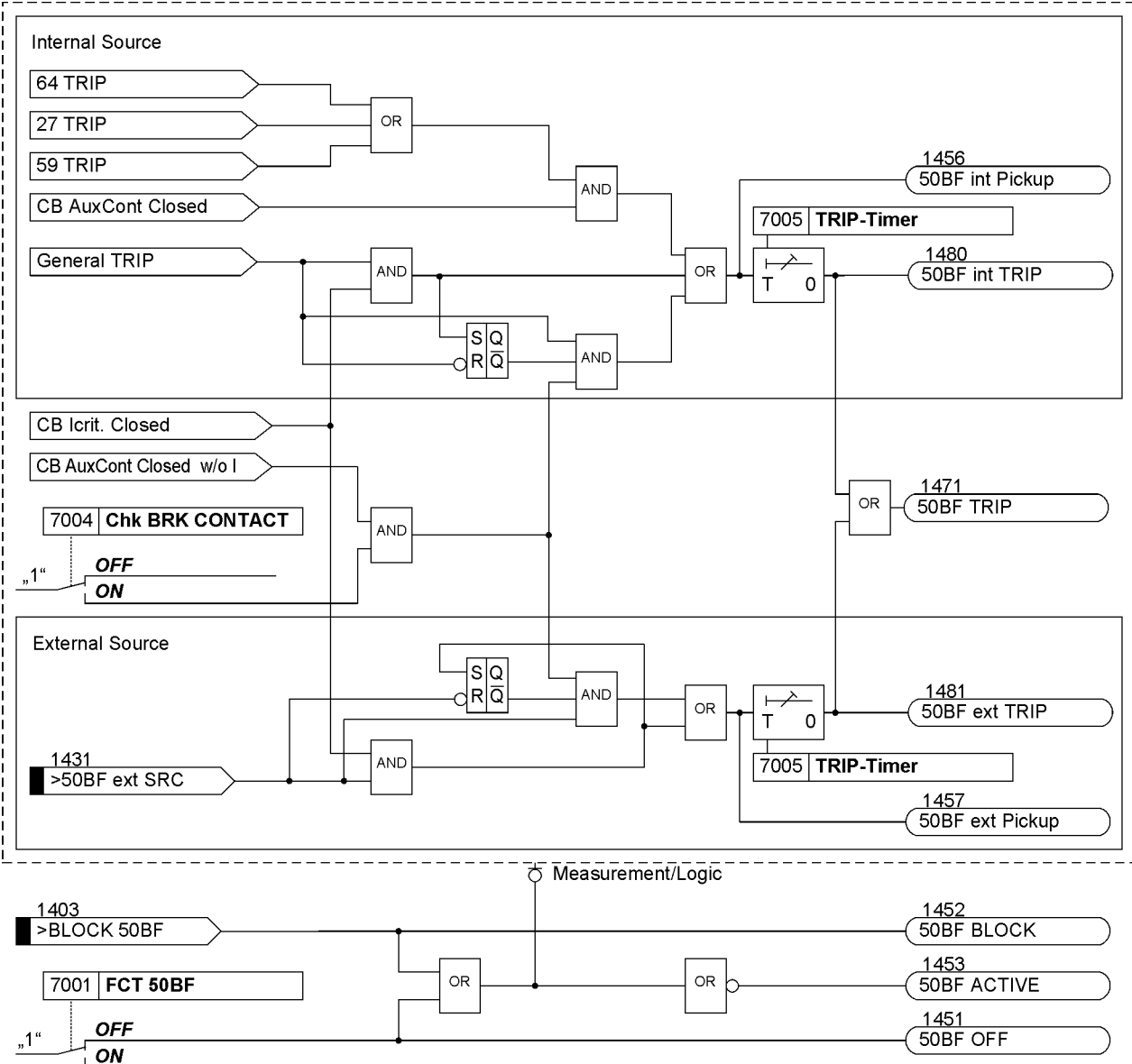

Figure 2-109 Logic diagram of the breaker failure protection

2.17.2 Setting Notes

General

Breaker failure protection is only effective and accessible if address 170 **50BF** is set to **Enabled** or **enabled w/ 3IO>**. Setting **Enabled** considers the three phase currents for total current monitoring. Setting **enabled w/ 3IO>** additionally evaluates the ground current or the negative sequence system when only one phase current occurs.

If this function is not required, then **Disabled** is set. The function can be set to **ON** or **OFF** under address 7001 **FCT 50BF**.

Criteria

Address 7004 **Chk BRK CONTACT** establishes whether or not the breaker auxiliary contacts connected via binary inputs are to be used as a criterion for pickup. If this address is set to **ON**, then current criterion and/or the auxiliary contact criterion apply. This setting must be selected if the breaker failure protection is started by functions, which do not always have a certain criterion for detection of an open circuit breaker, e.g. voltage protection.

Time Delay

The time delay is entered at address 7005 **TRIP-Timer**. This setting should be based on the maximum circuit breaker operating time plus the dropout time of the current flow monitoring element plus a safety margin which takes into consideration the tolerance of the time delay. Figure 2-110 illustrates the time sequences.

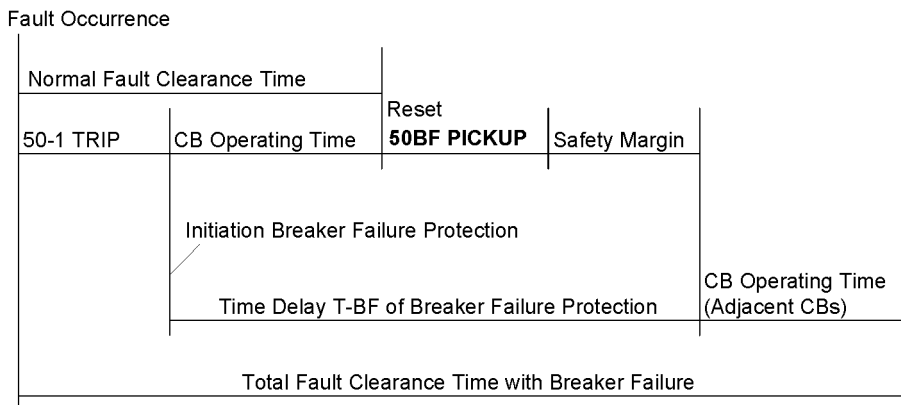

Figure 2-110 Time sequence example for normal clearance of a fault, and with circuit breaker failure

Pickup Values

The pickup value of the current flow monitoring is set under address 7006 **50BF PICKUP**, and the pickup value of the ground current monitoring under address 7007 **50BF PICKUP IE>**. The threshold values must be set at a level below the minimum fault current for which the total current monitoring must operate. A setting of 10 % below the minimum fault current for which breaker failure protection must operate is recommended. The pickup value should not be set too low since otherwise there is a risk that transients in the current transformer secondary circuit may lead to extended dropout times if extremely high currents are switched off.

Via binary input 1404 „>50BFactiv.3IO>“ you can activate the threshold value **50BF PICKUP IE>** also for checking the plausibility of the phase currents.

2.17.3 Settings

The table indicates region-specific default settings. Column C (configuration) indicates the corresponding secondary nominal current of the current transformer.

Addr.	Parameter	C	Setting Options	Default Setting	Comments
7001	FCT 50BF		OFF ON	OFF	50BF Breaker Failure Protection
7004	Chk BRK CONTACT		OFF ON	OFF	Check Breaker contacts
7005	TRIP-Timer		0.06 .. 60.00 sec; ∞	0.25 sec	TRIP-Timer
7006	50BF PICKUP	1A	0.05 .. 20.00 A	0.10 A	50BF Pickup current threshold
		5A	0.25 .. 100.00 A	0.50 A	
7007	50BF PICKUP IE>	1A	0.05 .. 20.00 A	0.10 A	50BF Pickup earth current threshold
		5A	0.25 .. 100.00 A	0.50 A	

2.17.4 Information List

No.	Information	Type of Information	Comments
1403	>BLOCK 50BF	SP	>BLOCK 50BF
1404	>50BFactiv.3I0>	SP	>50BF Activate 3I0> threshold
1431	>50BF ext SRC	SP	>50BF initiated externally
1451	50BF OFF	OUT	50BF is switched OFF
1452	50BF BLOCK	OUT	50BF is BLOCKED
1453	50BF ACTIVE	OUT	50BF is ACTIVE
1456	50BF int Pickup	OUT	50BF (internal) PICKUP
1457	50BF ext Pickup	OUT	50BF (external) PICKUP
1471	50BF TRIP	OUT	50BF TRIP
1480	50BF int TRIP	OUT	50BF (internal) TRIP
1481	50BF ext TRIP	OUT	50BF (external) TRIP

2.18 Flexible Protection Functions

The flexible protection function is applicable for a variety of protection principles. The user can create up to 20 flexible protection functions and configure them according to their function. Each function can be used either as an autonomous protection function, as an additional protective element of an existing protection function or as a universal logic, e.g. for monitoring tasks.

2.18.1 Description

General

The function is a combination of a standard protection logic and a characteristic (measured quantity or derived quantity) that is adjustable via parameters. The characteristics listed in table 2-18 and the derived protection functions are available.

Please note that the power values are not available if you are using capacitive voltage measurement, or if you have selected the setting **Vab, Vbc** or **Vab, Vbc, VSyn** or **Vab, Vbc, Vx** or **Vph-g, VSyn** as connection type for the voltage transformers in address 213 **VT Connect. 3ph**.

Table 2-18 Possible Protection Functions

Characteristic Group	Characteristic / Measured Quantity		Protective Function	ANSI No.	Mode of Operation	
					Three-phase	Single-phase
Current	I	RMS value of fundamental component	Overcurrent protection Undercurrent monitoring	50, 50G 37	X	X
	I_{rms}	True RMS (RMS value)	Overcurrent protection Thermal overload protection Undercurrent monitoring	50, 50G 49 37	X	X
	$3I_0$	Zero sequence system	Time overcurrent protection, ground	50N	X	
	I_1	Positive-sequence component			X	
	I_2	Negative-sequence component	Negative sequence protection	46	X	
	I_2/I_1	Positive/negative sequence component ratio			X	
Frequency	f	Frequency	Frequency protection	81U/O	without phase reference	
	df/dt	Frequency change	Frequency change protection	81R		
Voltage	V	RMS value of fundamental component	Voltage protection Displacement voltage	27, 59, 59G	X	X
	V_{rms}	True RMS (RMS value)	Voltage protection Displacement voltage	27, 59, 59G	X	X
	$3V_0$	Zero sequence system	Displacement voltage	59N	X	
	V_1	Positive-sequence component	Voltage protection	27, 59	X	
	V_2	Negative-sequence component	Voltage asymmetry	47	X	
	dV/dt	Voltage change	Voltage change protection	27R, 59R	X	

Characteristic Group	Characteristic / Measured Quantity		Protective Function	ANSI No.	Mode of Operation	
					Three-phase	Single-phase
Power	P	Real power	Reverse power protection Power protection	32R, 32, 37	X	X
	Q	Reactive power	Power protection	32	X	X
	cos φ	Power factor	Power factor	55	X	X
Binary input	–	Binary input	Direct coupling		without phase reference	

Section 2.19 gives an application example of the function „reverse power protection“.

The maximum 20 configurable protection functions operate independently of each other. The following description concerns one function; it can be applied accordingly to all other flexible functions. The logic diagram 2-111 illustrates the description.

Functional Logic

The function can be switched **ON** and **OFF** or, it can be set to **Alarm Only**. In this status, a pickup condition will neither initiate fault recording nor start the trip time delay. Tripping is thus not possible.

Changing the Power System Data 1 after flexible functions have been configured may cause these functions to be set incorrectly. Message (FNo.235.2128 „\$00 inval.set“) reports this condition. The function is inactive in this case and function's setting has to be modified.

Blocking Functions

The function can be blocked via binary input (FNo. 235.2110 „>BLOCK \$00“) or via local operating terminal („Control“ -> „Tagging“ -> „Set“). Blocking will reset the function's entire measurement logic as well as all running times and indications. Blocking via the local operating terminal may be useful if the function is in a status of permanent pickup which does not allow the function to be reset. In context with voltage-based characteristics, the function can be blocked if one of the measuring voltages fails. Recognition of this status is either accomplished by the relay's internal „Fuse-Failure-Monitor“ (FNo. 170 „VT FuseFail“; see section 2.11.1) or via auxiliary contacts of the voltage transformer CB (FNo. 6509 „>FAIL:FEEDER VT“ and FNo. 6510 „>FAIL: BUS VT“). This blocking mechanism can be enabled or disabled in the according parameters. The associated parameter **BLK.by Vol.Loss** is only available if the characteristic is based on a voltage measurement.

When using the flexible function for power protection or power monitoring, it will be blocked if currents fall below $0.03 I_{Nom}$.

Parameter **BLK f out of r** allows you to specify whether the protection function is blocked if the measured power frequency is outside the operating range of the function (25 Hz to 70 Hz).

Operating Mode, Measured Quantity, Measurement Method

The flexible function can be tailored to assume a specific protective function for a concrete application in parameters **OPERRAT. MODE**, **MEAS. QUANTITY**, **MEAS. METHOD** and **PICKUP WITH**. Parameter **OPERRAT. MODE** can be set to specify whether the function works **3-phase**, **1-phase** or **no reference**, i.e. without a fixed phase reference. The three-phase method evaluates all three phases in parallel. This implies that threshold evaluation, pickup indications and trip time delay are accomplished selectively for each phase and parallel to each other. This may be for example the typical operating principle of a three-phase time overcurrent protection. When operating single-phase, the function employs either a phase's measured quantity, which must be stated explicitly, (e.g. evaluating only the current in phase **I_b**), the measured ground current **I_n** or the measured displacement voltage **V_n**. If the characteristic relates to the frequency or if external trip commands are used, the operating principle is without (fixed) phase reference. Additional parameters can be set to specify the used **MEAS. QUANTITY** and the **MEAS. METHOD**. The **MEAS. METHOD** determines for current and voltage

measured values whether the function uses the RMS value of the fundamental component or the normal RMS value (true RMS) that evaluates also harmonics. All other characteristics use always the rms value of the fundamental component. Parameter **PICKUP WITH** moreover specifies whether the function picks up on exceeding the threshold (>-Element) or on falling below the threshold (<-Element).

Characteristic Curve

The function's characteristic curve is always „definite time“; this means that the time delay is not affected by the measured quantity.

Function Logic

Figure 2-111 shows the logic diagram of a three-phase function. If the function operates on one phase or without phase reference, phase selectivity and phase-specific indications are not relevant.

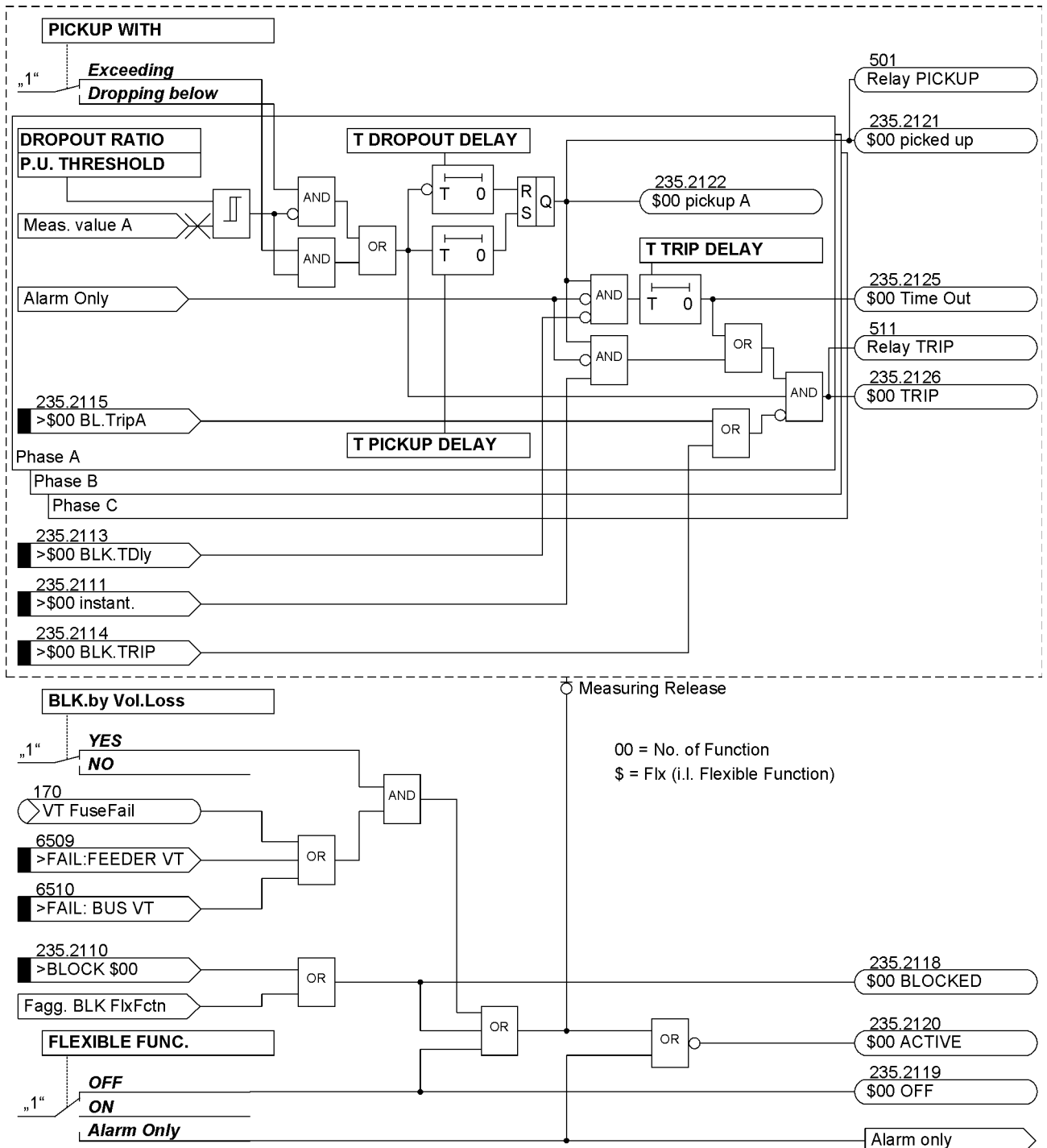

Figure 2-111 Logic diagram of the flexible protection functions

The parameters can be set to monitor either exceeding or dropping below of the threshold. The configurable pickup time delay will be started once the threshold (>-Element) has been exceeded. When the time delay has elapsed and the threshold is still violated, the pickup of the phase (e.g. no. 235.2122 „\$00 pickup A“) and of the function (no. 235.2121 „\$00 picked up“) is reported. If the pickup delay is set to zero, the pickup will occur simultaneously with the detection of the threshold violation. If the function is enabled, the pickup will start the trip time delay and the fault log. This is not the case if set to "Alarm only". If the threshold violation persists after the trip time delay has elapsed, the trip will be initiated upon its expiration (no. 235.2126 „\$00 TRIP“). The timeout is reported via (no. 235.2125 „\$00 Time Out“). Expiry of the trip time delay can be blocked via

binary input (no. 235.2113 „>\$00 BLK.TD1y“). The time delay will not be started as long as the binary input is active; a trip can thus be initiated. The time delay is started after the binary input has dropped out and the pickup is still present. It is also possible to bypass the expiration of the time delay by activating binary input (no. 235.2111 „>\$00 instant.“). The trip will be launched immediately when the pickup is present and the binary input has been activated. The trip command can be blocked via binary inputs (no. 235.2115 „>\$00 BL.TripA“) and (no. 235.2114 „>\$00 BLK.TRIP“). The phase-selective blocking of the trip command is required for interaction with the inrush restraint (see „Interaction with other functions“). The function's dropout ratio can be set. If the threshold (>-Element) is undershot after the pickup, the dropout time delay will be started. The pickup is maintained during that time, a started trip delay time continues to count down. If the trip time delay has elapsed while the dropout time delay is still during, the trip command will only be given if the current threshold is exceeded. The element will only drop out when the dropout time delay has elapsed. If the time is set to zero, the dropout will be initiated immediately once the threshold is undershot.

External Trip Commands

The logic diagram does not explicitly depict the external trip commands since their functionality is analogous. If the binary input is activated for external trip commands (no. 235.2112 „>\$00 Dir.TRIP“), it will be logically treated as threshold overshooting, i.e. once it has been activated, the pickup time delay is started. If the pickup time delay is set to zero, the pickup condition will be reported immediately starting the trip time delay. Otherwise, the logic is the same as depicted in Figure 2-111.

Interaction with Other Functions

The flexible protection functions interact with a number of other functions such as the

- Breaker failure protection:

The breaker failure protection is started automatically if the function initiates a trip. The trip will, however, only take place if the current criterion is met at this time, i.e. the set minimum current threshold 212 **BkrClosed I MIN** (Power System Data 1) has been exceeded.

- Automatic reclosing (AR):

The AR cannot be started directly. In order to interact with the AR, the trip command of the flexible function needs be linked in CFC to binary input no. 2716 „>Start 79 Ph“ or no. 2715 „>Start 79 Gnd“. Using an operating time requires the pickup of the flexible function to be linked to binary input no. 2711 „>79 Start“.

- Fuse-Failure-Monitor (see description at „Blocking Functions“).
- Inrush restraint:

Direct interaction with the inrush restraint is not possible. In order to block a flexible function by the inrush restraint, the blocking must be carried out in CFC. The flexible function provides three binary inputs for blocking trip commands selectively for each phase (no. 235.2115 to 235.2117). They have to be linked with the phase-selective indications for detecting the inrush (no. 1840 to 1842). Activating a crossblock function requires the phase-selective inrush indications to be logically combined with the binary input for blocking the function trip command (no. 235.2114 „>\$00 BLK.TRIP“). The flexible function also needs to be delayed by at least 20 ms to make sure that the inrush restraint picks up before the flexible function.

- Entire relay logic:

The pickup signal of the flexible function is added to the general device pickup, the trip signal is added to the general device trip (see also Chapter 2.22). All functions associated with general device pickup and tripping are thus also applied to the flexible function.

After the picked up element has dropped out, the trip signals of the flexible protection functions are held up at least for the specified minimum trip command time 210 T TRIPCOM MIN.

2.18.2 Setting Notes

The setting of the functional scope determines the number of flexible protection functions to be used (see Chapter 2.1.1). If a flexible function in the functional scope is disabled (by removing the checkmark), this will result in losing all settings and configurations of this function or its settings will be reset to their default settings.

General

In the DIGSI setting dialog „General“, parameter **FLEXIBLE FUNC.** can be set to **OFF**, **ON** or **Alarm Only**. If the function is enabled in operational mode **Alarm Only**, no faults are recorded, no „Effective“-indication is generated, no trip command issued and neither will the circuit-breaker protection be affected. Therefore, this operational mode is preferred when a flexible function is not required to operate as a protection function. Furthermore, the **OPERRAT. MODE** can be configured:

Three-phase – functions evaluate the three-phase measuring system, i.e. all three phases are processed simultaneously. A typical example is the three-phase operating time overcurrent protection.

Single-phase functions evaluate only the individual measured value. This can be an individual phase value (e.g. V_B) or V_x or a ground value (V_N , I_N or I_{N2}).

Setting **no reference** determines the evaluation of measured variables irrespective of a single or three-phase connection of current and voltage. Table 2-18 provides an overview regarding which variables can be used in which mode of operation.

Parameter **BLK f out of r** allows you to specify whether the protection function is blocked if the measured power frequency is outside the operating range of the function (25 Hz to 70 Hz). SIEMENS recommends using the default setting (**YES**). A release beyond the normal operating range is only required for special applications.

Measured values

In the setting dialog „Measured Variable“ the measured variables to be evaluated by the flexible protection functions can be selected, which may be a calculated or a directly measured variable. The setting options that can be selected here are dependent on the mode of measured-value processing as predefined in parameter **OPERRAT. MODE** (see the following table).

Table 2-19 Parameter “Operating Mode” and “Measured Quantity”

Parameter OPERRAT. MODE Setting	Parameter MEAS. QUANTITY Setting Options
Single-phase, Three-phase	Current Voltage P forward P reverse Q forward Q reverse Power factor
3-phase	dV/dt rising dV/dt falling
Without Reference	Frequency df/dt rising df/dt falling Binray Input

The power values are not available if you have selected the setting **Vab**, **Vbc** or **Vab**, **Vbc**, **VSyn** or **Vab**, **Vbc**, **Vx** or **Vph-g**, **VSyn** as connection type for the voltage transformers in address 213 **VT Connect. 3ph**.

Measurement Method

The measurement procedures as set out in the following table can be configured for the measured variables - current, voltage and power. The dependencies of the available measurement procedures of configurable modes of operation and the measured variable are also indicated.

Table 2-20 Parameter in the Settings Dialog "Measurement Procedure", Mode of Operation three-phase

Mode of Operation	Measured Variable		Notes
Three-phase	Current, Voltage	Parameter MEAS. METHOD Setting Options	
		Fundamental Harmonic	Only the fundamental harmonic is evaluated, higher harmonics are suppressed. This is the standard measurement procedure of the protection functions. Important: The voltage threshold is always parameterized as phase-to-phase voltage independently of parameter VOLTAGE SYSTEM.
		True RMS	The "true" RMS value is determined, i.e. higher harmonics are evaluated. This procedure is applied, for example, if a simple overload protection is to be implemented on the basis of a current measurement, as the higher harmonics contribute to thermal heating. Important: The voltage threshold is always parameterized as phase-to-phase voltage independently of parameter VOLTAGE SYSTEM.
		Positive sequence system, Negative sequence system, Zero sequence system	In order to implement certain applications, the positive sequence system or negative sequence system can be configured as measurement procedure. Examples are: - I2 (tripping monitoring system) - U2 (voltage asymmetry) Selecting the selection zero-sequence system enables additional zero-sequence current or zero-sequence voltage functions to be implemented that operate independently of the ground variables IN and VN, which are measured directly via transformers. Important: The voltage threshold value is always parameterized according to the definition of the symmetrical components independent of parameter VOLTAGE SYSTEM.
	Current	Ratio I2/I1	The ratio negative/positive sequence current is evaluated Please note that the function only operates if I2 or I1 has exceeded the threshold value $0.1 \cdot I_{Nom}$.
	Voltage	Parameter VOLTAGE SYSTEM Setting Options	
		Phase-to-phase Phase-to-Ground	If you have configured address 213 VT Connect. 3ph to Van, Vbn, Vcn or Vab, Vbc, VGnd, you can select whether a three-phase voltage function will evaluate the phase-to-Ground voltage or the phase-to-phase voltages. When selecting phase-to-phase, these variables are derived from the phase-to-Ground voltages. The selection is, for example, important for single-pole faults. If the faulty voltage drops to zero, the affected phase-to-Ground voltage is zero, whereas the affected phase-to-phase voltages collapse to the size of a phase-to-Ground voltage. With phase-to-phase voltage connections the parameter is hidden.



Note

With regard to the phase-selective pickup messages, a special behavior is observed in the three-phase voltage protection with phase-to-phase variables, because the phase-selective pickup message "Flx01 Pickup Lx" is allocated to the respective measured-value channel "Lx".

Single-phase faults:

If, for example, voltage V_A drops to such degree that voltages V_{AB} and V_{CA} exceed their threshold values, the device indicates pickups "Flx01 Pickup A" and "Flx01 Pickup C", because the undershooting was detected in the first and third measured-value channel.

Two-phase faults:

If, for example, voltage V_{AB} drops to such degree that its threshold value is reached, the device then indicates pickup "Flx01 Pickup A", because the undershooting was detected in the first measured-value channel.

Table 2-21 Parameter in the Setting Dialog "Measurement Procedure", Mode of Operation 1-phase

Mode of Operation	Measured Variable		Notes	
Single-phase	Current, voltage	Parameter MEAS. METHOD Setting Options		
		Fundamental Harmonic	Only the fundamental harmonic is evaluated, higher harmonics are suppressed. This is the standard measurement procedure of the protection functions.	
		True RMS	The „True“ RMS value is determined, i.e. higher harmonics are evaluated. This procedure is applied, for example, if a simple overload protection is to be implemented on the basis of a current measurement, as the higher harmonics contribute to thermal heating.	
	Current	Parameter CURRENT Setting Selection		
		IA IB IC IN INS IN2	It is determined which current measuring channel is evaluated by the function. Depending on the device version, either IN (normal-sensitive ground current input), INS (sensitive ground current input) or IN2 (second ground current connected to the device) can be selected. If parameter 251 is set to A,G2,C,G; G2->B, the setting IN refers to the current at the second current (IN2). The setting INS refers to the sensitive ground current at the fourth current input. If parameter 251 is set to A,G2,C,G; G->B, the setting IN2 refers to the current at the second current (IN2). The setting INS or INS refers to the sensitive or highly sensitive ground current at the fourth current input.	
	Voltage	Parameter VOLTAGE Setting Selection		
		VAB VBC VCA VAN VBN VCN VN Vx	It is determined which voltage-measuring channel is evaluated by the function. When selecting phase-to-phase voltage, the threshold value must be set as a phase-to-phase value, when selecting a phase-to-Ground variable as phase-to-Ground voltage. The extent of the setting texts depends on the connection of the voltage transformer (see address 213 VT Connect. 3ph).	
		P forward, P reverse, Q forward, Q reverse	Parameter POWER Setting Selection	
		IA VAN IB VBN IC VCN	It is determined which power-measuring channel (current and voltage) is evaluated by the function. The extent of the setting texts depends on the connection of the voltage transformer (see address 213 VT Connect. 3ph). When selecting Vab, Vbc, VGnd, the phase-to-Ground voltages will be calculated if „phase-to-Ground“ is configured. When selecting „phase-to-phase“, the connected phase-to-phase voltages are used and VCA is calculated from VAB and VBC.	



Note

If you have selected **Vph-g, VSyn** in **VT Connect. 3ph**, the connected phase-to-Ground voltage can be processed. If you select **VOLTAGE** as measured quantity, this connected voltage is used automatically.

The forward direction of power (P forward, Q reverse) is the direction of the line. Parameter (1108 **P,Q sign**) for sign inversion of the power display in the operating measured values is ignored by the flexible functions.

Via parameter **PICKUP WITH** it is determined whether the function must be triggered on exceeding or under-shooting of the set threshold value.

Settings

The pickup thresholds, time delays and dropout ratios of the flexible protection function are set in the „Settings“ dialog box in DIGSI.

The pickup threshold of the function is configured via parameter **P.U. THRESHOLD**. The OFF-command time delay is set via parameter **T TRIP DELAY**. Both setting values must be selected according to the required application.

The pickup can be delayed via parameter **T PICKUP DELAY**. This parameter is usually set to zero (default setting) in protection applications, because a protection function should pick up as quickly as possible. A setting deviating from zero may be appropriate if a trip log is not desired to be started upon each short-term exceeding of the pickup threshold, for example, with power protection or when a function is not used as a protection, but as a monitoring function.

When setting the power threshold values, it is important to take into consideration that a minimum current of $0.03 I_N$ is required for power calculation. The power calculation is blocked for lower currents.

The dropout of pickup can be delayed via parameter **T DROPOUT DELAY**. This setting is also set to zero by default (standard setting). A setting deviating from zero may be required if the device is utilized together with electro-magnetic devices with considerably longer dropout ratios than the digital protection device (see Chapter 2.2 for more information). When utilizing the dropout time delay, it is recommended to set it to a shorter time than the OFF-command time delay in order to avoid both times to "race".

The dropout ratio of the function can be selected in parameter **DROPOUT RATIO**. The standard dropout ratio of protection functions is 0.95 (default setting). If the function is used as power protection, a dropout ratio of at least 0.9 should be set. The same applies to the utilization of the symmetrical components of current and voltage. If the dropout ratio is decreased, it would be sensible to test the pickup of the function regarding possible "chatter".

The dropout difference of the frequency elements is set under parameter **DO differential**. Usually, the default setting of 0.02 Hz can be retained. A higher dropout difference should be set in weak systems with larger, short-term frequency fluctuations to avoid chattering of the message.

A fixed dropout difference of 0.1 Hz/s is used for the frequency change (df/dt) measurand. The same applies to the voltage change (dU/dt) measurand. The permanent dropout difference here is 3 V/s.

Parameter **BLK.by Vol. Loss** determines whether a function whose measured variable is based on a voltage measurement (measured quantities voltage, P forward, P reverse, Q forward, Q reverse and power factor), should be blocked in case of a measured voltage failure (set to **YES**) or not (set to **NO**).

Renaming Messages, Checking Configurations

After parameterization of a flexible function, the following steps should be noted:

- Open matrix in DIGSI
- Rename the neutral message texts in accordance with the application.
- Check configurations on contacts and in operation and fault buffer, or set them according to the requirements.

Further Information

The following instruction should be noted:

- As the power factor does not differentiate between capacitive and inductive, the sign of the reactive power may be used with CFC-help as an additional criterion.

2.18.3 Settings

Addresses which have an appended "A" can only be changed with DIGSI, under "Display Additional Settings".

The table indicates region-specific default settings. Column C (configuration) indicates the corresponding secondary nominal current of the current transformer.

Addr.	Parameter	C	Setting Options	Default Setting	Comments
0	FLEXIBLE FUNC.		OFF ON Alarm Only	OFF	Flexible Function
0	OPERRAT. MODE		3-phase 1-phase no reference	3-phase	Mode of Operation
0	BLK f out of r		YES NO	YES	Block while Freq. is out of range
0	MEAS. QUANTITY		Please select Current Voltage P forward P reverse Q forward Q reverse Power factor dV/dt rising dV/dt falling Frequency df/dt rising df/dt falling Binray Input	Please select	Selection of Measured Quantity
0	MEAS. METHOD		Fundamental True RMS Positive seq. Negative seq. Zero sequence Ratio I2/I1	Fundamental	Selection of Measurement Method
0	PICKUP WITH		Exceeding Dropping below	Exceeding	Pickup with
0	CURRENT		Ia Ib Ic In In sensitive In2	Ia	Current
0	VOLTAGE		Please select Va-n Vb-n Vc-n Va-b Vb-c Vc-a Vn Vx	Please select	Voltage

Addr.	Parameter	C	Setting Options	Default Setting	Comments
0	POWER		Ia Va-n Ib Vb-n Ic Vc-n	Ia Va-n	Power
0	VOLTAGE SYSTEM		Phase-Phase Phase-Ground	Phase-Phase	Voltage System
0	P.U. THRESHOLD		0.05 .. 40.00 A	2.00 A	Pickup Threshold
0	P.U. THRESHOLD	1A	0.05 .. 40.00 A	2.00 A	Pickup Threshold
		5A	0.25 .. 200.00 A	10.00 A	
0	P.U. THRESHOLD	1A	0.001 .. 1.500 A	0.100 A	Pickup Threshold
		5A	0.005 .. 7.500 A	0.500 A	
0	P.U. THRESHOLD		2.0 .. 260.0 V	110.0 V	Pickup Threshold
0	P.U. THRESHOLD		2.0 .. 200.0 V	110.0 V	Pickup Threshold
0	P.U. THRESHOLD		40.00 .. 60.00 Hz	51.00 Hz	Pickup Threshold
0	P.U. THRESHOLD		50.00 .. 70.00 Hz	61.00 Hz	Pickup Threshold
0	P.U. THRESHOLD		0.10 .. 20.00 Hz/s	5.00 Hz/s	Pickup Threshold
0	P.U. THRESHOLD	1A	2.0 .. 10000.0 W	200.0 W	Pickup Threshold
		5A	10.0 .. 50000.0 W	1000.0 W	
0	P.U. THRESHOLD		-0.99 .. 0.99	0.50	Pickup Threshold
0	P.U. THRESHOLD		15 .. 100 %	20 %	Pickup Threshold
0	P.U. THRESHOLD		4 .. 100 V/s	60 V/s	Pickup Threshold
0	P.U. THRESHOLD		2.0 .. 260.0 V	110.0 V	Pickup Threshold
0	T TRIP DELAY		0.00 .. 3600.00 sec	1.00 sec	Trip Time Delay
0A	T PICKUP DELAY		0.00 .. 60.00 sec	0.00 sec	Pickup Time Delay
0	T PICKUP DELAY		0.00 .. 28800.00 sec	0.00 sec	Pickup Time Delay
0A	T DROPOUT DELAY		0.00 .. 60.00 sec	0.00 sec	Dropout Time Delay
0A	BLK.by Vol.Loss		NO YES	YES	Block in case of Meas.- Voltage Loss
0A	DROPOUT RATIO		0.70 .. 0.99	0.95	Dropout Ratio
0A	DROPOUT RATIO		1.01 .. 3.00	1.05	Dropout Ratio
0	DO differential		0.02 .. 1.00 Hz	0.03 Hz	Dropout differential

2.18.4 Information List

No.	Information	Type of Information	Comments
235.2110	>BLOCK \$00	SP	>BLOCK Function \$00
235.2111	>\$00 instant.	SP	>Function \$00 instantaneous TRIP
235.2112	>\$00 Dir.TRIP	SP	>Function \$00 Direct TRIP
235.2113	>\$00 BLK.TDly	SP	>Function \$00 BLOCK TRIP Time Delay
235.2114	>\$00 BLK.TRIP	SP	>Function \$00 BLOCK TRIP
235.2115	>\$00 BL.TripA	SP	>Function \$00 BLOCK TRIP Phase A
235.2116	>\$00 BL.TripB	SP	>Function \$00 BLOCK TRIP Phase B
235.2117	>\$00 BL.TripC	SP	>Function \$00 BLOCK TRIP Phase C
235.2118	\$00 BLOCKED	OUT	Function \$00 is BLOCKED
235.2119	\$00 OFF	OUT	Function \$00 is switched OFF
235.2120	\$00 ACTIVE	OUT	Function \$00 is ACTIVE
235.2121	\$00 picked up	OUT	Function \$00 picked up
235.2122	\$00 pickup A	OUT	Function \$00 Pickup Phase A
235.2123	\$00 pickup B	OUT	Function \$00 Pickup Phase B
235.2124	\$00 pickup C	OUT	Function \$00 Pickup Phase C
235.2125	\$00 Time Out	OUT	Function \$00 TRIP Delay Time Out
235.2126	\$00 TRIP	OUT	Function \$00 TRIP
235.2128	\$00 inval.set	OUT	Function \$00 has invalid settings
236.2127	BLK. Flex.Fct.	IntSP	BLOCK Flexible Function

2.19 Reverse-Power Protection Application with Flexible Protection Function

2.19.1 Description

By means of the flexible protection functions, a single-element or multi-element reverse power protection can be realized. Each reverse power element can be operated in single-phase or three-phase. Depending on the chosen option, the elements can evaluate active power forward, active power reverse, reactive power forward or reactive power reverse as measured value. The pickup of the protection elements can occur on exceeding or falling below a threshold. Possible applications for reverse power protection are set out in Table 2-22.

Table 2-22 Overview of reverse power protection applications

	Direction	Type of evaluation	
		Exceeding	Falling below
P	forward	Monitoring of the forward power limits of operational equipment (transformers, lines)	Detection of idling motors
	reverse	Protection of a local industrial network against feedback into the power supply network Detection of feedback from motors	
Q	forward	Monitoring of the reactive power limits of operational equipment (transformers, lines) Connection of a capacitor bank for reactive power compensation	
	reverse	Monitoring of the reactive power limits of operational equipment (transformers, lines) Disconnection of a capacitor bank	

The following example depicts a typical application where the flexible function acts as reverse power protection.

Disconnection Facility

Figure 2-112 gives an example of an industrial substation with self-supply via the illustrated generator. All illustrated lines and the busbar are three-phase (except for the ground connections and the connection to the voltage measurement at the generator). Both feeders 1 and 2 supply the consumers of the customer. Usually the industrial customer receives his current from the power supply company. The generator runs synchronously without feeding power. If the power supply company can no longer guarantee the required supply, the substation is to be separated from the power supply company's system and the generator to take over the self-supply. In this example, the substation is to be disconnected from the power supply company's system as soon as the frequency leaves the nominal range (e.g. 1 - 2% deviation from the nominal frequency), the voltage exceeds or falls below a set value, or the generator's active power is fed back into the power supply company's system. Depending on the user's philosophy, some of these criteria may be combined. This would be realized via the CFC.

The example illustrates how a reverse power protection is implemented by means of the flexible protection functions. Frequency protection and voltage protection are described in Sections 2.8 and 2.6.

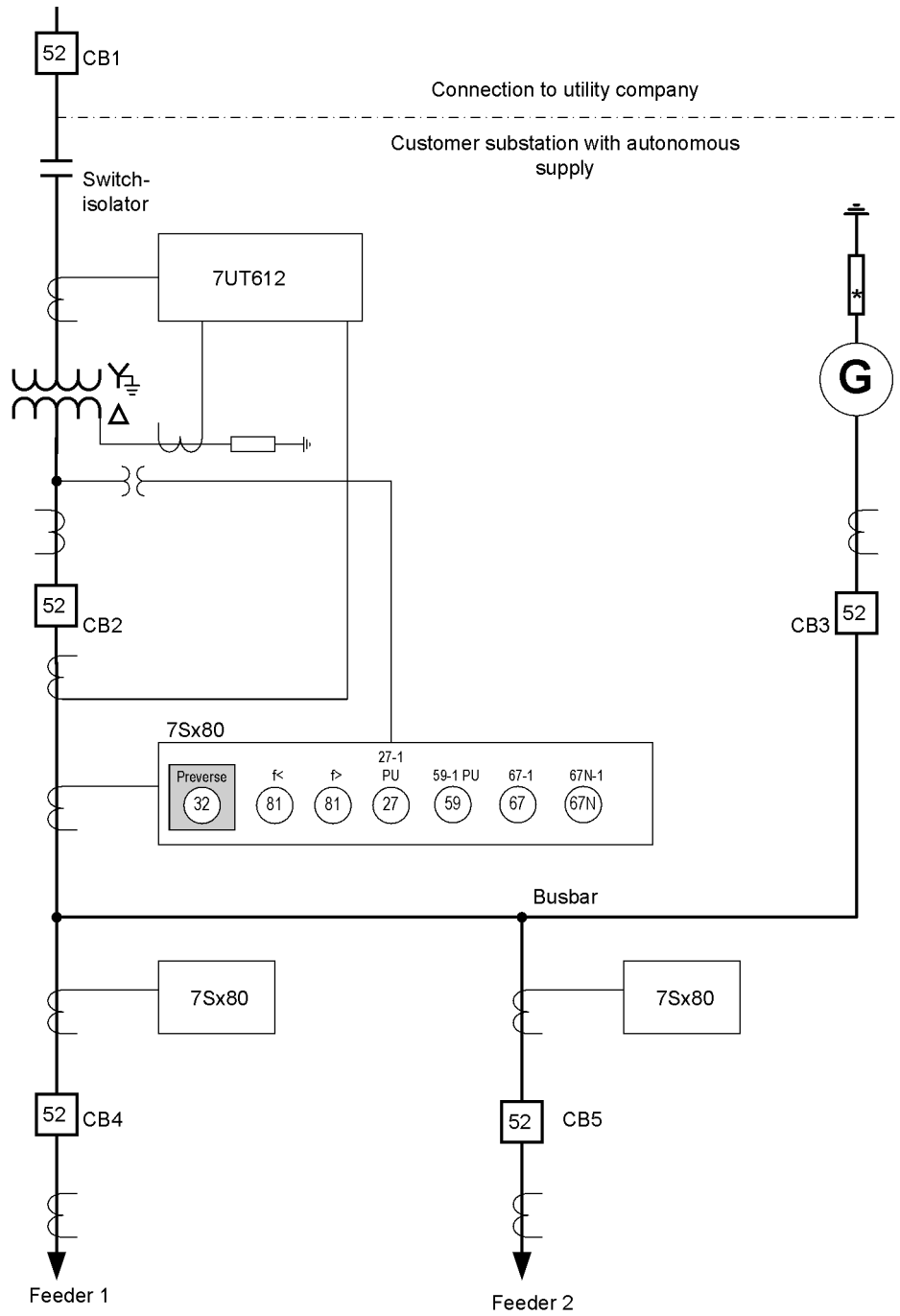

Figure 2-112 Example of a substation with generator self-supply

Substation Layout

On the high-voltage side, the substation is linked to the power supply company's system via a 110 kV line. The circuit breaker CB1 is part of the power supply company's system. Disconnection of the substation from the power supply company's system is effected via the switch disconnecter. The transformer with a transformation ratio of 10:1 transforms the voltage level to 11 kV. On the low-voltage side, the transformer, generator and two feeders are linked via a busbar. The circuit breakers CB2 to CB5 separate the consumers and operational equipment from the busbar.

Table 2-23 System data for the application example

System data	
Generator nominal power	$S_{Nom,Gen} = 38.1 \text{ MVA}$
Transformer nominal power	$S_{Nom,Transf} = 38.1 \text{ MVA}$
Nominal voltage of the high-voltage side	$V_{Nom} = 110 \text{ kV}$
Nominal voltage of busbar side	$V_{Nom} = 11 \text{ kV}$
Nominal primary CT current on the busbar side	$I_{Nom,prim} = 2000 \text{ A}$
Nominal secondary CT current on the busbar side	$I_{Nom,sec} = 1 \text{ A}$
Nominal primary VT voltage on the busbar side	$V_{Nom,prim} = 11 \text{ kV}$
Nominal secondary VT voltage on the busbar side	$V_{Nom,sec} = 100 \text{ V}$

Protection Functionality

With the protection device 7SJ80, the substation is disconnected from the generator upon its feedback into the power supply company's system (protection function **P reverse>**). This function is implemented by means of a flexible protection function. Additionally, the disconnection is effected in the case of frequency or voltage fluctuations in the power supply company's system (protection functions **f<**, **f>**, **27-1 PICKUP**, **59-1 PICKUP**, **67-1 PICKUP_{dir.}**, **67N-1 PICKUP_{dir.}**). The protection receives the measured values via a three-phase current and voltage transformer set. In the case of a disconnection, the circuit breaker CB2 is triggered.

The transformer is protected by a differential protection and inverse or definite time overcurrent protection functions for the phase-to-phase currents. In the event of a fault, the circuit-breaker CB1 in the power supply company's system is activated via a remote link. In addition, the circuit breaker CB2 is activated.

Overcurrent protection functions protect the feeders 1 and 2 against short circuits and overload caused by the connected consumers. The phase-to-phase currents and the zero currents of the feeders can be protected by inverse and definite time overcurrent protection elements. In the event of a fault, the circuit breakers CB4 and CB5 are activated.

In addition, the busbar could be equipped with the 7UT635 differential protection relay for multiple ends. The current transformers required for that are already included in Figure 2-112.

Wiring Diagram, Power Direction

Figure 2-113 shows the wiring of the device for reverse power protection. The power flow in positive or forward direction occurs from the high-voltage busbar (not shown) via the transformer to the low-voltage busbar.

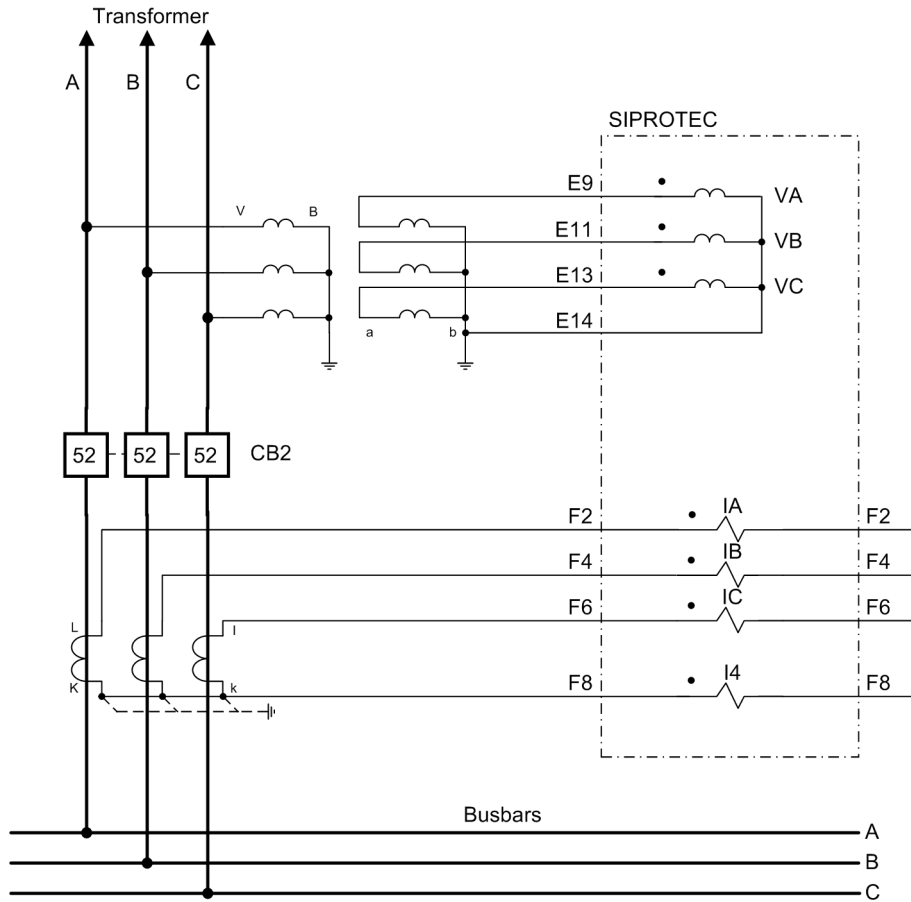

Figure 2-113 Wiring diagram for a 7SJ80 as reverse power protection

2.19.2 Implementation of the Reverse Power Protection

General

The names of messages can be edited in DIGSI and adjusted accordingly for this example. The names of the parameters are fixed.

Determination of the Reverse Power

The reverse power protection evaluates the active power from the symmetrical components of the fundamental harmonics of the voltages and currents. The evaluation of the positive sequence systems causes reverse power determination to be independent of the asymmetries in currents and voltages and reflects the real load of the driving end. The calculated active power value corresponds to the total active power. The connection in the example illustrates positive measurement of power in the direction extending from the busbar to the transformer of the device.

Functional Logic

The following logic diagram depicts the functional logic of the reverse power protection.

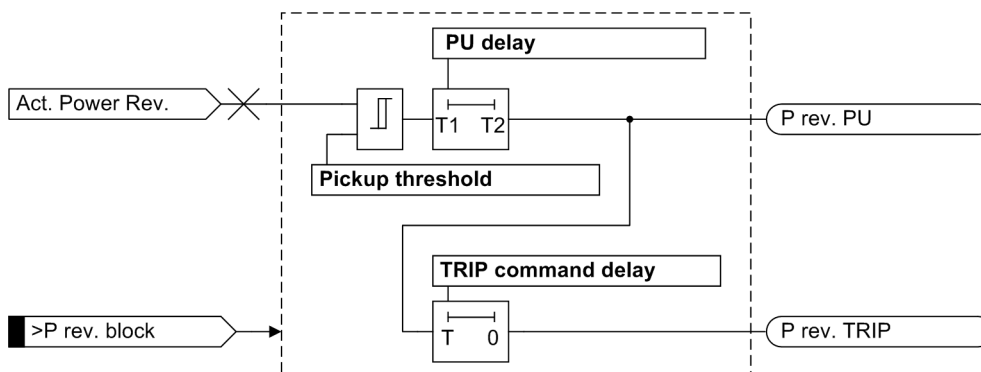

Figure 2-114 Logic diagram of the reverse power determination with flexible protection function

The reverse power protection picks up once the configured pickup threshold has been exceeded. If the pickup condition persists during the equally settable pickup delay, the pickup message **P.rev.PU** is generated and starts the trip delay time. If the pickup condition does not drop out while the trip delay time is counting down, the trip indication **P. rev. TRIP** and the timeout indication **P. rev. timeout** (not shown) are generated. The picked up element drops out when the value falls below the dropout threshold. The blocking input **>P rev. block** blocks the entire function, i.e. pickup, trip and running times are reset. After the blocking has been released, the reverse power must exceed the pickup threshold and both times must run out before the protection function trips.

Pickup Value, Dropout Ratio

The pickup value of the reverse power protection is set to 10% of the nominal generator output. In this example, the setting value is configured as secondary power in watts. The following relationship exists between the primary and the secondary power:

$$P_{\text{sec}} = P_{\text{prim}} \cdot \frac{V_{\text{Nom, sec}}}{V_{\text{Nom, prim}}} \cdot \frac{I_{\text{Nom, sec}}}{I_{\text{Nom, prim}}}$$

On the basis of the indicated data, the pickup values are calculated considering $P_{\text{prim}} = 3.81 \text{ MW}$ (10% of 38.1 MW) on the primary level to

$$P_{\text{sec}} = 3.81 \text{ MW} \cdot \frac{100 \text{ V}}{11000 \text{ V}} \cdot \frac{1 \text{ A}}{2000 \text{ A}} = 17.3 \text{ W}$$

on the secondary level. The dropout ratio is set to 0.9. This yields a secondary dropout threshold of $P_{\text{sec, dropout}} = 15.6 \text{ W}$. If the pickup threshold is reduced to a value near the lower setting limit of 0.5 W, the dropout ratio should equally be reduced to approximately 0.7.

Delay for Pickup, Dropout and Trip

The reverse power protection does not require short tripping times as protection from undesired power feedback. In the present example, it is useful to delay pickup and dropout by about 0.5 s and the trip by approx. 1 s. Delaying the pickup will minimize the number of fault logs which are opened when the reverse power oscillates around the threshold.

When using the reverse power protection to disconnect the substation quickly from the power supply company's system if faults occur, it is useful to select a larger pickup value (e.g. 50% of nominal power) and shorter time delays.

2.19.3 Configuring the Reverse Power Protection in DIGSI

First create and open a 7SJ80 device in the DIGSI manager. In the scope of functions, a flexible protection function (flexible function 01) is configured for the present example.

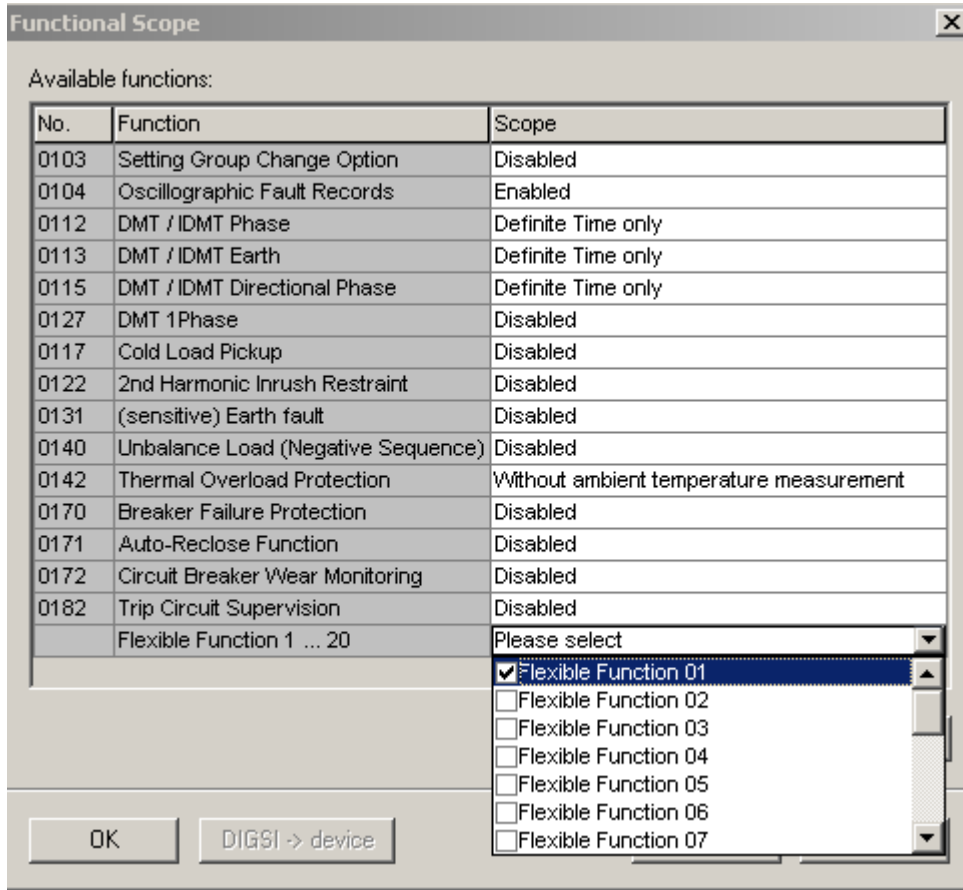

Figure 2-115 Configuration of a flexible protection function

Select „Additional Functions“ in the „Parameters“ menu to view the flexible function. The parameter selection options for the flexible protection functions primarily depend on the settings made in the **Power System Data 1** for the connection of the voltage and current transformers (addresses 213 and 251).

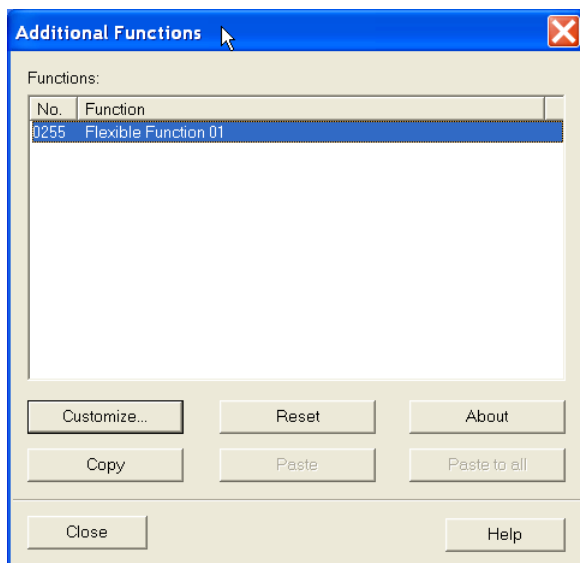

Figure 2-116 Configuration of a flexible protection function

First activate the function at „Customize --> General“ and select the mode of operation „Three-Phase“.

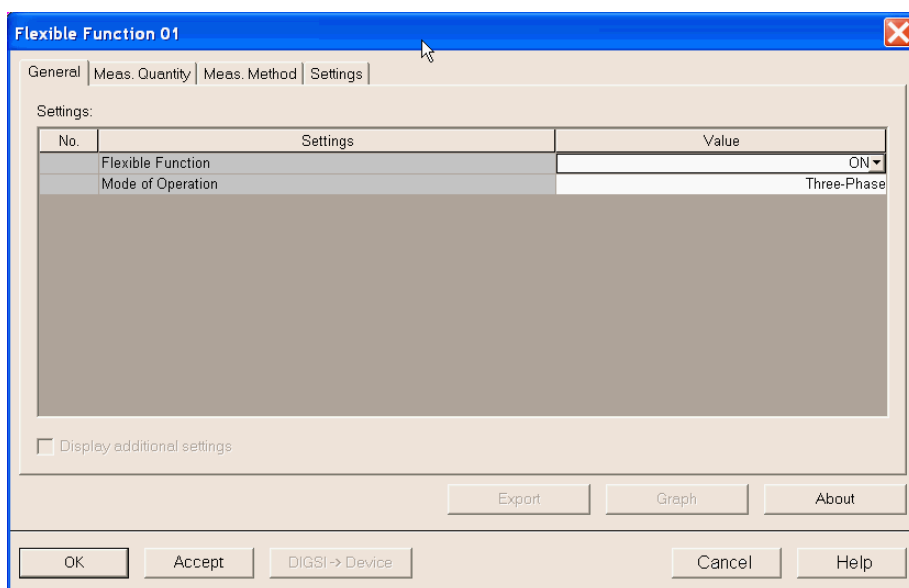

Figure 2-117 Selection of the three-phase mode of operation

In the menu items „Meas. Quantity“ and „Meas. Method“, „Active Power reverse“ or „Exceeding“ must be set. If the box „Display additional settings“ is enabled in the „Settings“ menu item, pickup threshold, pickup time delay and dropout time delay can be configured. As the power direction cannot be determined in the case of a measuring voltage failure, a protection blocking is sensible in this case.

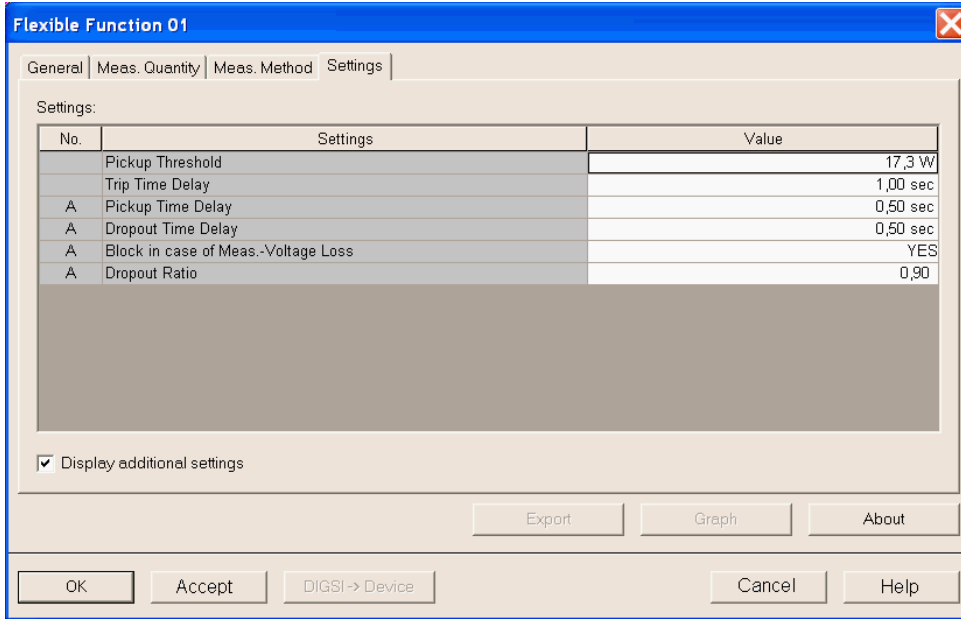

Figure 2-118 Setting options for the flexible function

Allocation of the Reverse Power Protection

The DIGSI configuration matrix initially shows the following indications (after having selected „Indications and commands only“ and „No filter“):

Flx 01	235.2110.01	>BLOCK Flx01	>BLOCK Function Flx01	SP		
	235.2111.01	>Flx01 instant.	>Function Flx01 instantaneous TRIP	SP		
	235.2113.01	>Flx01 BLK.TDelay	>Function Flx01 BLOCK TRIP Time Delay	SP		
	235.2114.01	>Flx01 BLK. TRIP	>Function Flx01 BLOCK TRIP	SP		
	235.2118.01	Flx01 BLOCKED	Function Flx01 is BLOCKED	OUT		
	235.2119.01	Flx01 OFF	Function Flx01 is switched OFF	OUT		
	235.2120.01	Flx01 ACTIVE	Function Flx01 is ACTIVE	OUT		
	235.2121.01	Flx01 picked up	Function Flx01 picked up	OUT		
	235.2125.01	Flx01 Time Out	Function Flx01 TRIP Delay Time Out	OUT		
	235.2126.01	Flx01 TRIP	Function Flx01 TRIP	OUT		

Figure 2-119 Information of the flexible function – default setting

Clicking the texts allows for editing short text and long text as required by the application.

Flx 01	235.2110.01	>P rev. block	>Active power reverse block	SP		
	235.2111.01	>P rev. instant	>Active pow. rev. OFF instantaneous trip	SP		
	235.2113.01	>P rev. BLK. T	>Active pow. rev. BLOCK TRIP Time Delay	SP		
	235.2114.01	>P rev. BLK. TRIP	>Active pow. rev. BLOCK TRIP	SP		
	235.2118.01	P rev. BLOCKED	Active pow. rev. is BLOCKED	OUT		
	235.2119.01	P rev. OFF	Active pow. rev. is switched OFF	OUT		
	235.2120.01	P rev. ACTIVE	Active pow. rev. is ACTIVE	OUT		
	235.2121.01	P rev. picked up	Active pow. rev. picked up	OUT		
	235.2125.01	P rev. Time Out	Active pow. rev. TRIP Delay Time Out	OUT		
	235.2126.01	P rev. TRIP	Active pow. rev. TRIP	OUT		

Figure 2-120 Messages of the flexible function – application-oriented, example

The indications are allocated in the same way as the indications of other protection functions.

2.20 Synchrocheck

When connecting two sections of a power system, the synchrocheck function verifies that the switching does not endanger the stability of the power system

Applications

- Typical applications are, for example, the synchronization of a feeder and a busbar or the synchronization of two busbars via tie-breaker.

2.20.1 General

Synchronous power systems exhibit small differences regarding frequency and voltage values. Before connection it is to be checked whether the conditions are synchronous or not. If the conditions are synchronous, the system is energized; if they are asynchronous, it is not. The circuit breaker operating time is not taken into consideration. The synchrocheck function is activated via address 161 **SYNCHROCHECK**.

For comparing the two voltages of the sections of the power system to be synchronized, the synchrocheck function uses the reference voltage V_1 and an additional voltage to be connected V_2 .

If a transformer is connected between the two voltage transformers as shown in the example Figure 2-121, its vector group can be adapted in the 7SJ80 relay so that there is no external adjustment required.

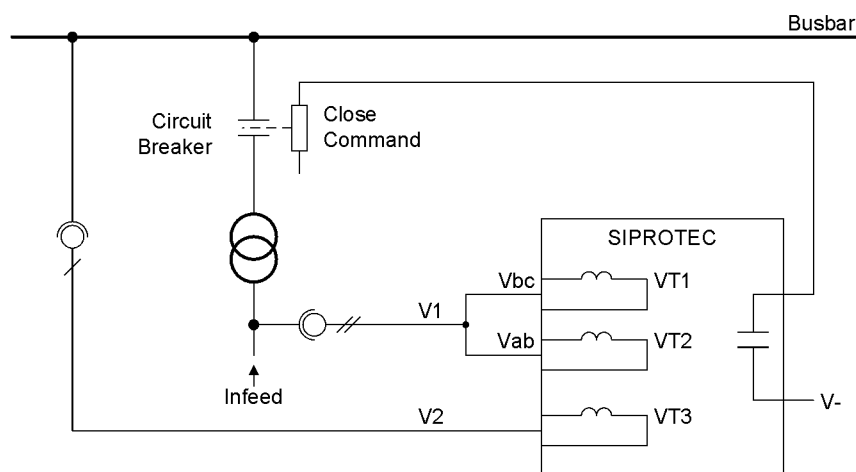

Figure 2-121 Infeed

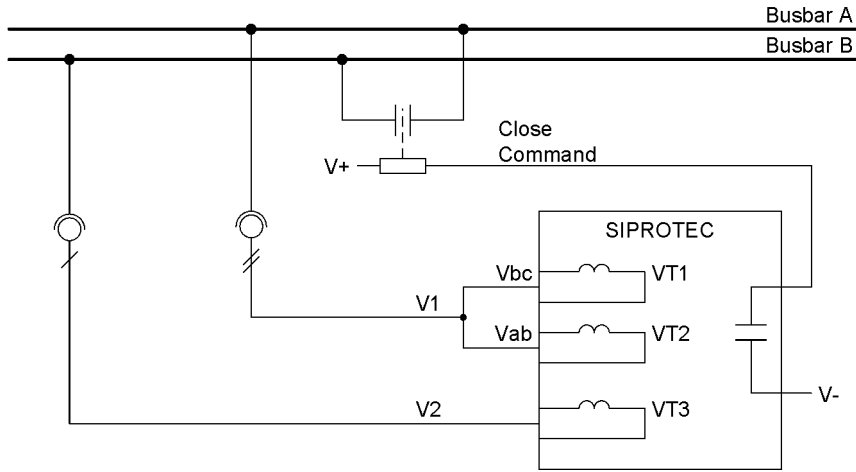

Figure 2-122 Cross coupling

The synchrocheck function of the 7SJ80 usually coordinates with the integrated automatic reclosing system and the control function. Nevertheless, it is also possible to employ an external automatic reclosing system. In such a case, the signal exchange between the devices is to be accomplished via binary inputs and outputs.

The configuration determines whether the synchrocheck is to be carried out only in the case of automatic reclosing or only in the case of circuit breaker control or in both cases. It is also possible to configure different release criteria for automatic reclosing or control closing. Synchronous connection is always accomplished via the integrated control.

The release command for closing under satisfied synchronism conditions can be deactivated via parameter 6113 **25 Synchron**. For special applications, the deactivated closing release can, however, be activated via a binary input („>25 synchr.“) (see „De-energized Switching“).

With a capacitive voltage connection, the synchrocheck function is not available.

Connection, Multi-phase

For comparing the two voltages, the synchrocheck function uses the reference voltage V_1 and an additional voltage to be connected V_2 . For the multi-phase connection, set the **P.System Data 1** at 213 **Vab, Vbc, VSyn**. With this setting, the device is connected as open-delta connection and the phase-to-phase voltages V_{AB} and V_{BC} are used as reference voltage V_1 . The voltage to be synchronized V_2 is assigned to the single-phase connection and may be any phase-to-phase voltage. The connected voltage is set at address 6123.

Furthermore, it should be noted that in the case of an open-delta connection, no zero voltage can be determined. In this case, the functions „Directional Ground Fault Detection“ and „Fuse Failure Monitor (FFM)“ must be hidden or disabled. The function „Directional Overcurrent Protection Ground“ then works with the negative sequence system values. Notes on the effects of the current transformer connection can be found in Chapter 2.1.3.2, Table 2-1.

Connection, Single-phase

If there is only one phase-to-Ground voltage available for the reference voltage V_1 , the device can be informed of this fact via the **P.System Data 1**, address 213 **Vph-g, VSyn**. Also in this case the synchrocheck function can be fully applied. For the voltage to be synchronized V_2 , the same phase-to-Ground voltage as for V_1 has to be connected.

Please note that some of the protection functions are restricted or do not work at all with this kind of connection. Notes on the effects of the current transformer connection can be found in Chapter 2.1.3.2, Table 2-1.

2.20.2 Functional Sequence

Validity Check of the Configuration

Already during startup of the device, a validation check of the configuration is performed. If there is a fault, the message „25 Set -Error“ is output. after a measurement request there is a condition which is not plausible, the message „25 Sync . Error“ is output. The measurement is then not started.

Concerning the configuration, it is also checked if the substation parameter 213 is set to **Vab**, **Vbc**, **VSyn** or **Vph-g**, **VSyn**. Furthermore, specific thresholds and settings of the function group are checked. If there is a condition which is not plausible, the error message „25 Set -Error“ is output additionally. Please ensure in this case that address 6106 (threshold V1, V2 energized) is smaller than address 6103 (lower voltage limit **Vmin**). The synchrocheck function cannot be controlled via a binary input.

SYNC Error

The synchronization is not started if a voltage transformer failure (m.c.b. tripping) is communicated to the device via the binary input 6509 „>FAIL:FEEDER VT“ or 6510 „>FAIL: BUS VT“. The message „25 Sync . Error“ is output. In this case, the synchronization can be controlled directly via a binary input.

Release

The synchrocheck function only operates if it receives a measurement request. This request may be issued by the internal control function, the automatic reclosing function or externally via a binary input, e.g. from an external automatic reclosing system.

Before a release for closing is granted, the following conditions are checked:

- Is the reference voltage V_1 above the setting value **Vmin** but below the maximum voltage **Vmax**?
- Is the voltage V_2 to be synchronized above the setting value **Vmin** but below the maximum voltage **Vmax**?
- Is the voltage difference $V_2 - V_1$ within the permissible limit **dV SYNCHK V2>V1**?
- Is the voltage difference $V_1 - V_2$ within the permissible limit **dV SYNCHK V2<V1**?
- Are the two frequencies f_1 and f_2 within the permissible operating range $f_N \pm 3$ Hz?
- Is the frequency difference $f_2 - f_1$ within the permissible limit **df SYNCHK f2>f1**?
- Is the frequency difference $f_1 - f_2$ within the permissible limit **df SYNCHK f2<f1**?
- Is the angle difference $\alpha_2 - \alpha_1$ within the permissible limit **d α SYNCHK $\alpha_2>\alpha_1$** ?
- Is the angle difference $\alpha_1 - \alpha_2$ within the permissible limit **d α SYNCHK $\alpha_2<\alpha_1$** ?

If there is a condition which is not plausible, the message „25 Sync . Error“ is output and the measurement is not started. the conditions are plausible, the measurement is started (message „25 - 1 meas .“) and the configured release conditions are checked.

Each condition which is met is indicated explicitly (messages „25 Vdiff ok“, „25 fdiff ok“, „25 α diff ok“). Conditions which are not met are also indicated explicitly, e.g. when the voltage difference (messages „25 V2>V1“, „25 V2<V1“), frequency difference (messages „25 f2>f1“, „25 f2<f1“) or angle difference (messages „25 $\alpha_2>\alpha_1$ “, „25 $\alpha_2<\alpha_1$ “) is outside the limit values. The precondition for these messages is that both voltages are within the operating range of the synchrocheck function (see „Operating Range“).

If the conditions are met, the synchrocheck function issues a release signal for closing the relay („25 CloseRelease“). This release signal is only available for the configured duration of the CLOSE command and is processed by the device's function control as CLOSE command to the circuit breaker (see also margin heading „Interaction with Control“). However, the message „25 Synchron“ is applied as long as the synchronous conditions are met.

The measurement of the the synchronism conditions can be confined to the a maximum monitoring time **T-SYN. DURATION**. If the conditions are not met within **T-SYN. DURATION**, the release is cancelled (message „25 MonTimeExc“). A new synchronization can only be performed if a new measurement request is received.

Operating Range

The operating range of the synchrocheck function is defined by the configured voltage limits **V_{min}** and **V_{max}** as well as the fixed frequency band $f_{Nom} \pm 3$ Hz.

If the measurement is started and one of or both voltages are outside the operating range or one of the voltages leaves the operating range, this is indicated by corresponding messages („25 f1>>“, „25 f1<<“, „25 V1>>“, „25 V1<<“).

Measured Values

The measured values of the synchrocheck function are displayed in separate windows for primary, secondary and percentaged measured values. The measured values are displayed and updated only while the synchrocheck function is requested.

The following is displayed:

- Value of the reference voltage V_1
- Value of the voltage to be synchronized V_2
- Frequency values f_1 and f_2
- Differences of voltage, frequency and angle.

2.20.3 De-energized Switching

Connecting two components of a power system is also possible if at least one of the components is de-energized and if the measured voltage is greater than the threshold $V >$. With a multi-phase connection on the side V_1 , all connected voltages must have a higher value than the threshold $V >$ so that the side V_1 is considered as being energized. With a single-phase connection, of course, only the one voltage has to exceed the threshold value.

Besides the release under synchronous conditions, the following additional release conditions can be selected for the check:

SYNC V1>V2< =	Release on the condition that component V_1 is energized and component V_2 is de-energized.
SYNC V1<V2> =	Release on the condition that component V_1 is de-energized and component V_2 is energized.
SYNC V1<V2< =	Release on the condition that component V_1 and component V_2 are de-energized.

Each of these conditions can be enabled or disabled individually via parameters or binary inputs; combinations are thus also possible (e.g. release if **SYNC V1>V2<** or **SYNC V1<V2>** are fulfilled).

For that reason synchronization with the use of the additional parameter 6113 **25 Synchron** (configured to **NO**) can also be used for the connection of a ground electrode. In such a case, connection is only permissible when there is no voltage on the load side.

The threshold below which a power system component is considered as being de-energized is defined by parameter **V<**. If the measured voltage exceeds the threshold **V>**, a power system component is considered as being energized. With a multi-phase connection on the side V_1 , all connected voltages must have a higher value than the threshold **V>** so that the side V_1 is considered as being energized. With a single-phase connection, of course, only the one voltage has to exceed the threshold value.

Before granting a release for connecting the energized component V_1 and the de-energized component V_2 , the following conditions are checked:

- Is the reference voltage V_1 above the setting value **Vmin** and **V>** but below the maximum voltage **Vmax**?
- Is the voltage to be synchronized V_2 below the setting value **V<**?
- Is the frequency f_1 within the permissible operating range $f_{Nom} \pm 3$ Hz?

After successful completion of the checks, the release is granted.

For connecting the de-energized component 1 to the energized component 2 or the de-energized component 1 to the de-energized component 2, the conditions to be fulfilled correspond to those stated above.

The associated messages indicating the release via the corresponding condition are as follows: „25 V1>V2<“, „25 V1<V2>“ and „25 V1<V2<“.

Via the binary inputs „>25 V1>V2<“, „>25 V1<V2>“ and „>25 V1<V2<“, the release conditions can also be issued externally, provided the synchronization is controlled externally.

The parameter **TSUP VOLTAGE** (address 6111) can be set to configure a monitoring time which requires the additional release conditions stated above to be present for de-energized connection before connection is allowed.

2.20.4 Direct Command / Blocking

Parameter 6110 **Direct C0** can be set to grant a release without performing any checks. In this case, connection is allowed immediately when initiating the synchrocheck function. It is obviously not reasonable to combine **Direct C0** with other release conditions.

If the synchrocheck function fails, a direct command may be issued or not, depending on the type of failure (also see "Plausibility Check" and „SYNC Error“).

Via the binary input „>25direct C0“, this release can also be granted externally.

Blocking the entire synchrocheck function is possible via the binary input „>BLK 25 - 1“. The message signaling this condition is output via „25 - 1 BLOCK“. With the blocking, the measurement is terminated and the entire function is reset. A new measurement can only be performed with a new measurement request.

Via the binary input „>BLK 25 CLOSE“ it is possible to block only the release signal for closing („25 CloseRelease“). When the blocking is active, measurement continues. The blocking is indicated by the message „25 CLOSE BLK“. When the blocking is reset and the release conditions are still fulfilled, the release signal for closing is issued.

2.20.5 Interaction with Control, Automatic Reclosing and External Control

With Control

Basically, the synchrocheck function interacts with the device control. The switchgear component to be synchronized is selected via a parameter. If a CLOSE command is issued, the control takes into account that the switchgear component requires synchronization. The control sends a measurement request („25 Measu. req.“) to the synchrocheck function which is then started. Having completed the check, the synchrocheck function issues the release message („25 CloseRelease“) to which the control responds by terminating the switching operation either positively or negatively.

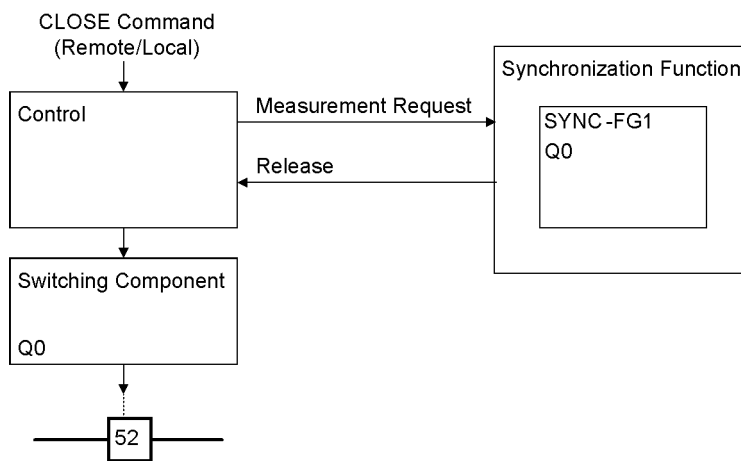

Figure 2-123 Interaction of control and synchrocheck function

With Automatic Reclosing

The automatic reclosing (AR) function can also interact with the synchrocheck function. They are linked via the device control. The selection is made via configuration in the automatic reclosing and synchrocheck function. The AR parameters (7138 **Internal SYNC**) determine whether working with SYNC function group 1 or - in the case of external synchronization - without SYNC function group. The switch to be used is defined in function group 1. The switchgear component indicated in the AR parameters (7137 **Cmd.via control**) and the SYNC function group must be identical. If no SYNC function group is entered in the AR parameters, the close command of the AR function is carried out asynchronously via the switchgear component indicated in the AR parameters. Equally, the CLOSE command „79 Close“ (message 2851) allows only asynchronous switching. If, for example, circuit breaker Q0 is configured as object to be switched synchronously, a CLOSE command of the AR function will address this breaker and assign it a CLOSE command which will be processed by the control. As this breaker requires synchronization, the control launches the synchrocheck function and awaits release. If the configured conditions of the SYNC function group are fulfilled, the release is granted and the control issues the CLOSE command.

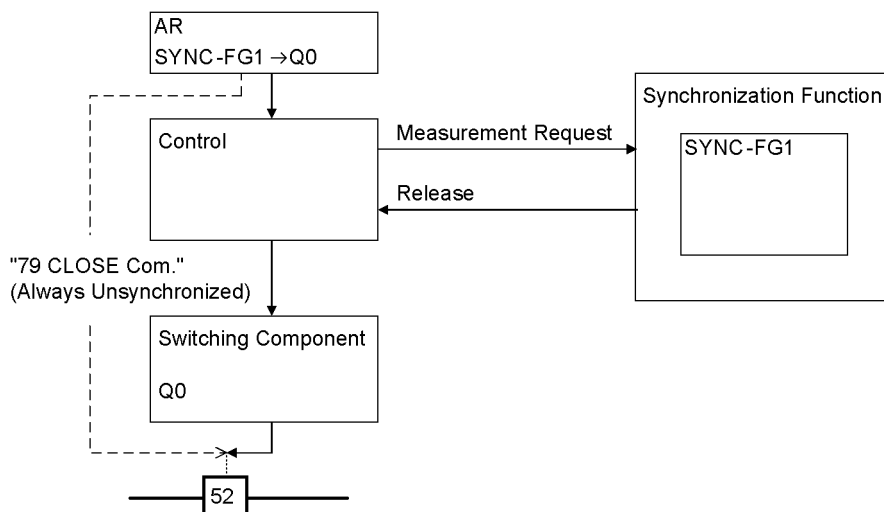

Figure 2-124 Connection of the automatic reclosing function to the synchrocheck function

With External Control

As another option, the synchrocheck function can be activated via external measurement requests. The synchrocheck function can be started via binary input using measurement request („>25 Sync requ.“ or pulse-like start and stop signals „>25 Start“, „>25 Stop“). Having completed the check, the synchrocheck function issues the release message („25 CloseRelease“) (see Figure). Measurement is terminated as soon as the measurement request is reset via the binary input. In this case, there is no need to configure a control device to be synchronized.

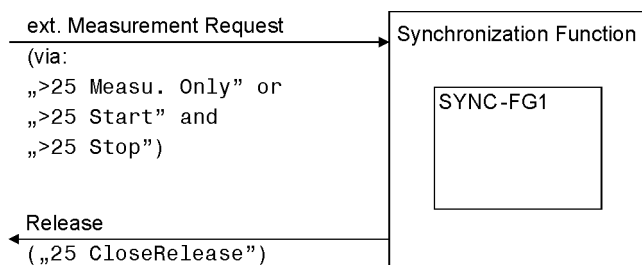

Figure 2-125 Interaction of synchrocheck function and external control

2.20.6 Setting Notes

General

The synchronization function can only operate if **25 Function 1** with **SYNCHROCHECK** was enabled at address 161 during configuration of the functional scope (see Section 2.1.1.2). If this function is not required, then **Disabled** is set.

While setting the power system data 1 (see Section 2.1.3.2) the device was already provided with data relevant for the measured values and the operating principle of the synchronization function. This concerns the following parameters:

202 **Vnom PRIMARY** primary nominal voltage of the voltage transformers V_1 (phase-to-phase) in kV;

203 **Vnom SECONDARY** secondary nominal voltage of the voltage transformers V_1 (phase-to-phase) in V;

213 **VT Connect. 3ph** specifies how the voltage transformers are connected.

When using the synchronization function the setting **Vab**, **Vbc**, **VSyn** is used if two phase-to-phase voltages are open delta-connected to the device. You can use any phase-to-phase voltage as the reference voltage V_{SYN} .

Use the setting **Vph-g**, **VSyn** if only phase-to-ground voltages are available. One of these voltages is connected to the first voltage transformer; the reference voltage V_{SYN} is connected to the third voltage transformer. V_A at the first voltage transformer and V_B at the third voltage transformer must belong to the same voltage type (VAN or VBN or VCN).

Connection examples are given under side heading „Voltage Connections“ and in the Appendix A.3.

If you have set **Vab**, **Vbc**, **VSyn** or **Vph-g**, **VSyn**, the zero sequence voltage can not be determined. The functions „Directional Ground Fault Detection“, „Directional Time Overcurrent Protection Ground“ and „Fuse Failure Monitor (FFM)“ are disabled in this case. Table 2-1 in the chapter 2.1.3.2 provides information about the consequences of the different voltage connection types.

The operating range of the synchronization function ($f_{\text{Nom}} \pm 3 \text{ Hz}$) refers to the nominal frequency of the power system, address 214 **Rated Frequency**.

The corresponding messages of the SYNC function group are pre-allocated for IEC 60870–5–103 (VDEW).

Selecting the SYNC function group in DIGSI opens a dialog box with tabs in which the individual parameters for synchronization can be set.

General

The general thresholds for the synchronizing function are set at addresses 6101 to 6112.

Address 6101 **Synchronizing** allows you to switch the entire SYNC function group **ON** or **OFF**. If switched off, the synchrocheck does not verify the synchronization conditions and release is not granted.

Parameter 6102 **SyncCB** is used to select the switchgear component to which the synchronization settings are applied. Select the option **none** to use the function as external synchronizing feature. It will then be triggered via binary input messages.

Addresses 6103 **Vmin** and 6104 **Vmax** set the upper and lower limits for the operating voltage range for V_1 or V_2 and thus determine the operating range for the synchronization function. Values outside this range will be signaled.

Address 6105 **V<** indicates the voltage threshold below which the feeder or the busbar can safely be considered switched off (for checking a de-energized feeder or busbar).

Address 6106 **V>** indicates the voltage threshold above which the feeder or busbar can safely be considered energized (for checking an energized feeder or busbar). It must be set below the anticipated operational undervoltage.

The setting for the mentioned voltage values is made in secondary volts. When using DIGSI for configuration, these values can also be entered as primary values. Depending on the connection of the voltages these are phase-to-earth voltages or phase-to-phase voltages.

Addresses 6107 to 6110 are set to specify the release conditions for the voltage check: Where

6107 **SYNC V1<V2>** = component V_1 must be de-energized, component V_2 must be energized (connection when reference is de-energized, dead line);

6108 **SYNC V1>V2<** = component V_1 must be energized, component V_2 must be de-energized (connection when feeder is de-energized, dead bus);

6109 **SYNC V1<V2<** = component V_1 and component V_2 must both be de-energized (connection when reference and feeder are de-energized, dead bus / dead line);

6110 **Direct C0** = connection released without checks.

The possible release conditions are independent of each other and can be combined. It is not recommended to combine **Direct C0** with other release conditions.

Parameter **TSUP VOLTAGE** (address 6111) can be set to configure a monitoring time which requires above stated release conditions to be present for at least de-energized switching before connection is allowed. The preset value of 0.1 s accounts for transient responses and can be applied without modification.

Release via synchrocheck can be limited to a configurable synchronous monitoring time **T-SYN. DURATION** (address 6112). The configured conditions must be fulfilled within this time period. Otherwise release is not granted and the synchronizing function is terminated. If this time is set to ∞ , the conditions will be checked until they are fulfilled.

For special applications (e.g. connecting a ground switch) parameter 6113 **25 Synchron** allows enabling/disabling the connection release when the conditions for synchronism are satisfied.

Power System Data

The system related data for the synchronization function are set at addresses 6121 to 6125.

The parameter **Balancing V1/V2** (address 6121) can be set to account for different VT ratios of the two parts of the power system (see example in Figure).

If a transformer is located between the system parts to be synchronized, its vector group can be accounted for by angle adjustment so that no external adjusting measures are required. Parameter **ANGLE ADJUSTM.** (address 6122) is used to this end.

The phase angle from V_1 to V_2 is evaluated positively.

Example: (see also Figure):

Busbar	400 kV primary; 100 V secondary
Feeder	220 kV primary; 110 V secondary
Transformer	400 kV/220 kV; vector group Dy(n)5

The transformer vector group is defined from the high side to the low side. In the example, the reference voltage transformers (V_1) are the ones of the transformer high side, i.e. the setting angle is $5 \times 30^\circ$ (according to vector group), that is 150° :

Address 6122 **ANGLE ADJUSTM.** = 150° .

The reference voltage transformers supply 100 V secondary for primary operation at nominal value while the feeder transformer supplies 110 V secondary. Therefore, this difference must be balanced:

Address 6121 **Balancing V1/V2** = $100 \text{ V}/110 \text{ V} = 0.91$.

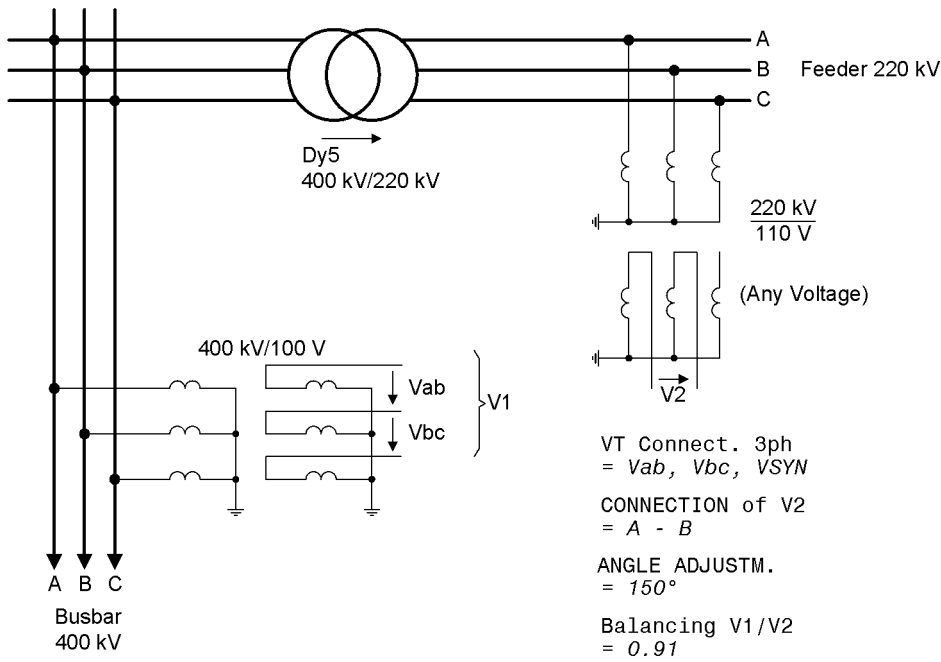

Figure 2-126 Busbar voltage measured across the transformer

Voltage Connections

The 7SJ80 provides two voltage inputs for connecting the voltage V_1 and one voltage input for connecting the voltage V_2 (see the following examples).

If two phase-to-phase voltages are open delta-connected to side V_1 as reference voltage, a phase-to-phase voltage must be connected and configured for the additional voltage V_2 to be synchronized.

To correctly compare the phase-to-phase reference voltage V_1 with the additional voltage V_2 , the device needs to know the connection type of voltage V_2 . That is the task of parameter **CONNECTION of V2** (parameter 6123).

For the device to perform the internal conversion to primary values, the primary rated transformer voltage of the measured quantity V_2 must be entered via parameter 6125 **VT Vn2, primary** if a transformer is located between the system parts to be synchronized.

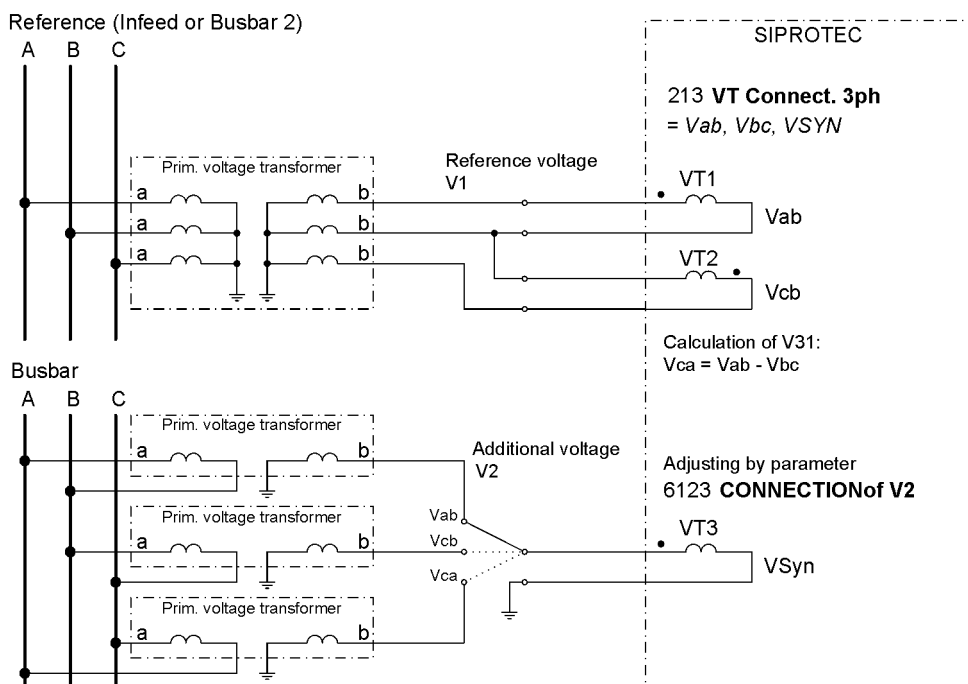

Figure 2-127 Phase-to-phase voltage connection (open-delta connection)

If only phase-to-ground voltages are available, the reference voltage V_1 is connected to the first voltage transformer and the additional voltage V_2 to the third voltage transformer.

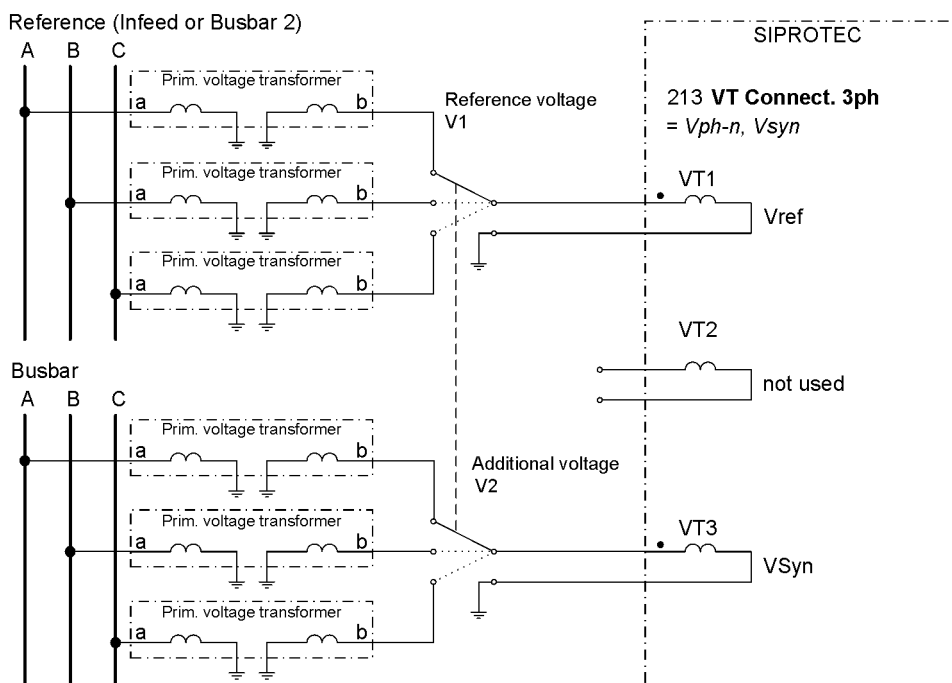

Figure 2-128 Phase-to-ground voltage connection

Voltage Difference

The parameters 6150 **dV SYNCHK V2>V1** and 6151 **dV SYNCHK V2<V1** can be set to adjust the permissible voltage differences asymmetrically. The availability of two parameters enables an asymmetrical release to be set.

2.20.7 Settings

Addresses which have an appended "A" can only be changed with DIGSI, under "Display Additional Settings".

Addr.	Parameter	Setting Options	Default Setting	Comments
6101	Synchronizing	ON OFF	OFF	Synchronizing Function
6102	SyncCB	(Setting options depend on configuration)	None	Synchronizable circuit breaker
6103	Vmin	20 .. 125 V	90 V	Minimum voltage limit: Vmin
6104	Vmax	20 .. 140 V	110 V	Maximum voltage limit: Vmax
6105	V<	1 .. 60 V	5 V	Threshold V1, V2 without voltage
6106	V>	20 .. 140 V	80 V	Threshold V1, V2 with voltage
6107	SYNC V1<V2>	YES NO	NO	ON-Command at V1< and V2>
6108	SYNC V1>V2<	YES NO	NO	ON-Command at V1> and V2<
6109	SYNC V1<V2<	YES NO	NO	ON-Command at V1< and V2<
6110A	Direct CO	YES NO	NO	Direct ON-Command
6111A	TSUP VOLTAGE	0.00 .. 60.00 sec	0.10 sec	Supervision time of V1>;V2> or V1<;V2<
6112	T-SYN. DURATION	0.01 .. 1200.00 sec; ∞	30.00 sec	Maximum duration of Synchronization
6113A	25 Synchron	YES NO	YES	Switching at synchronous condition
6121	Balancing V1/V2	0.50 .. 2.00	1.00	Balancing factor V1/V2
6122A	ANGLE ADJUSTM.	0 .. 360 °	0 °	Angle adjustment (transformer)
6123	CONNECTIONof V2	A-B B-C C-A	A-B	Connection of V2
6125	VT Vn2, primary	0.10 .. 800.00 kV	20.00 kV	VT nominal voltage V2, primary
6150	dV SYNCHK V2>V1	0.5 .. 50.0 V	5.0 V	Maximum voltage difference V2>V1
6151	dV SYNCHK V2<V1	0.5 .. 50.0 V	5.0 V	Maximum voltage difference V2<V1
6152	df SYNCHK f2>f1	0.01 .. 2.00 Hz	0.10 Hz	Maximum frequency difference f2>f1
6153	df SYNCHK f2<f1	0.01 .. 2.00 Hz	0.10 Hz	Maximum frequency difference f2<f1

Addr.	Parameter	Setting Options	Default Setting	Comments
6154	d α SYNCHK $\alpha_2 > \alpha_1$	2 .. 80 °	10 °	Maximum angle difference $\alpha_2 > \alpha_1$
6155	d α SYNCHK $\alpha_2 < \alpha_1$	2 .. 80 °	10 °	Maximum angle difference $\alpha_2 < \alpha_1$

2.20.8 Information List

No.	Information	Type of Information	Comments
170.0001	>25-1 act	SP	>25-group 1 activate
170.0043	>25 Sync requ.	SP	>25 Synchronization request
170.0049	25 CloseRelease	OUT	25 Sync. Release of CLOSE Command
170.0050	25 Sync. Error	OUT	25 Synchronization Error
170.0051	25-1 BLOCK	OUT	25-group 1 is BLOCKED
170.2007	25 Measu. req.	SP	25 Sync. Measuring request of Control
170.2008	>BLK 25-1	SP	>BLOCK 25-group 1
170.2009	>25direct CO	SP	>25 Direct Command output
170.2011	>25 Start	SP	>25 Start of synchronization
170.2012	>25 Stop	SP	>25 Stop of synchronization
170.2013	>25 V1>V2<	SP	>25 Switch to V1> and V2<
170.2014	>25 V1<V2>	SP	>25 Switch to V1< and V2>
170.2015	>25 V1<V2<	SP	>25 Switch to V1< and V2<
170.2016	>25 synchr.	SP	>25 Switch to Sync
170.2022	25-1 meas.	OUT	25-group 1: measurement in progress
170.2025	25 MonTimeExc	OUT	25 Monitoring time exceeded
170.2026	25 Synchron	OUT	25 Synchronization conditions okay
170.2027	25 V1> V2<	OUT	25 Condition V1>V2< fulfilled
170.2028	25 V1< V2>	OUT	25 Condition V1<V2> fulfilled
170.2029	25 V1< V2<	OUT	25 Condition V1<V2< fulfilled
170.2030	25 Vdiff ok	OUT	25 Voltage difference (Vdiff) okay
170.2031	25 fdiff ok	OUT	25 Frequency difference (fdiff) okay
170.2032	25 α diff ok	OUT	25 Angle difference (alphadiff) okay
170.2033	25 f1>>	OUT	25 Frequency f1 > fmax permissible
170.2034	25 f1<<	OUT	25 Frequency f1 < fmin permissible
170.2035	25 f2>>	OUT	25 Frequency f2 > fmax permissible
170.2036	25 f2<<	OUT	25 Frequency f2 < fmin permissible
170.2037	25 V1>>	OUT	25 Voltage V1 > Vmax permissible
170.2038	25 V1<<	OUT	25 Voltage V1 < Vmin permissible
170.2039	25 V2>>	OUT	25 Voltage V2 > Vmax permissible
170.2040	25 V2<<	OUT	25 Voltage V2 < Vmin permissible
170.2050	V1 =	MV	V1 =
170.2051	f1 =	MV	f1 =
170.2052	V2 =	MV	V2 =
170.2053	f2 =	MV	f2 =
170.2054	dV =	MV	dV =

No.	Information	Type of Information	Comments
170.2055	$df =$	MV	$df =$
170.2056	$d\alpha =$	MV	$d\alpha =$
170.2090	25 $V2 > V1$	OUT	25 Vdiff too large ($V2 > V1$)
170.2091	25 $V2 < V1$	OUT	25 Vdiff too large ($V2 < V1$)
170.2092	25 $f2 > f1$	OUT	25 fdiff too large ($f2 > f1$)
170.2093	25 $f2 < f1$	OUT	25 fdiff too large ($f2 < f1$)
170.2094	25 $\alpha2 > \alpha1$	OUT	25 alphadiff too large ($a2 > a1$)
170.2095	25 $\alpha2 < \alpha1$	OUT	25 alphadiff too large ($a2 < a1$)
170.2096	25 FG-Error	OUT	25 Multiple selection of func-groups
170.2097	25 Set-Error	OUT	25 Setting error
170.2101	25-1 OFF	OUT	Sync-group 1 is switched OFF
170.2102	>BLK 25 CLOSE	SP	>BLOCK 25 CLOSE command
170.2103	25 CLOSE BLK	OUT	25 CLOSE command is BLOCKED

2.21 Phase Rotation

A phase rotation reversal is implemented in the 7SJ80 using binary inputs and parameters.

Applications

- Phase rotation ensures that all protective and monitoring functions operate correctly even with anti-clockwise rotation, without the need for two phases to be reversed.

2.21.1 Description

General

Various functions of the 7SJ80 only operate correctly if the phase rotation of the voltages and currents is known. Among these functions are unbalanced load protection, undervoltage protection (based on positive sequence voltages), directional overcurrent protection (direction with cross-polarized voltages), and measured value supervision.

If an "acb" phase rotation is normal, the appropriate setting is made during configuration of the Power System Data.

If the phase rotation can change during operation, a reversal signal at the binary input configured for this purpose is sufficient to inform the protection device of the phase sequence reversal.

Logic

Phase rotation is permanently established at address 209 **PHASE SEQ.** (Power System Data). Via the exclusive-OR gate the binary input „>Reverse Rot.“ inverts the sense of the phase rotation applied with setting.

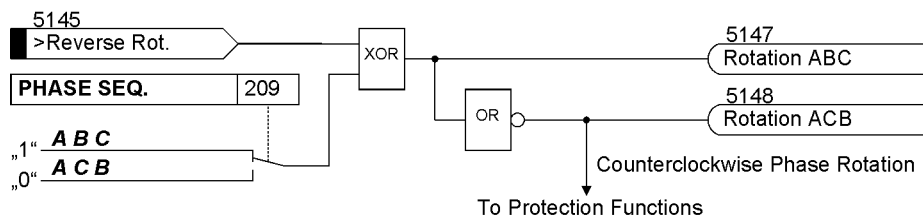

Figure 2-129 Message logic of the phase rotation reversal

Influence on Protective and Monitoring Functions

The swapping of phases directly impacts the calculation of positive and negative sequence quantities, as well as phase-to-phase voltages via the subtraction of one phase-to-Ground voltage from another and vice versa. Therefore, this function is vital so that phase detection messages, fault values, and operating measurement values are not correct. As stated before, this function influences the negative sequence protection function, directional overcurrent protection function, voltage protection function, flexible protection functions and some of the monitoring functions that issue messages if the defined and calculated phase rotations do not match.

2.21.2 Setting Notes

Setting the Function Parameter

The normal phase sequence is set at 209 (see Section 2.1.3). If, on the system side, phase rotation is reversed temporarily, then this is communicated to the protection device using the binary input „>Reverse Rot.“ (5145).

2.22 Function Logic

The function logic coordinates the execution of protection and auxiliary functions, it processes the resulting decisions and information received from the system. This includes in particular:

- Fault Detection / Pickup Logic
- Processing Tripping Logic

2.22.1 Pickup Logic of the Entire Device

General Device Pickup

The pickup signals for all protection functions in the device are connected via an OR logic and lead to the general device pickup. It is initiated by the first function to pick up and drop out when the last function drops out. As a consequence, the following message is reported: 501 „Relay PICKUP“.

The general pickup is a prerequisite for a number of internal and external consequential functions. The following are among the internal functions controlled by general device pickup:

- Start of a trip log: From general device pickup to general device dropout, all fault messages are entered in the trip log.
- Initialization of Oscillographic Records: The storage and maintenance of oscillographic values can also be made dependent on the general device pickup.

Exception: Apart from the settings **ON** or **OFF**, some protection functions can also be set to **Alarm Only**. With setting **Alarm Only** no trip command is given, no trip log is created, fault recording is not initiated and no spontaneous fault annunciations are shown on the display.

External functions may be controlled via an output contact. Examples are:

- Automatic reclosing devices,
- Starting of additional devices, or similar.

2.22.2 Tripping Logic of the Entire Device

General Tripping

The trip signals for all protective functions are connected by OR and generate the message 511 „Relay TRIP“.

This message can be configured to an LED or binary output, just as the individual tripping messages can.

Terminating the Trip Signal

Once the trip command is output by the protection function, it is recorded as message „Relay TRIP“ (see figure 2-130). At the same time, the minimum trip command duration **TMin TRIP CMD** is started. This ensures that the command is transmitted to the circuit breaker for a sufficient amount of time, even if the function which issued the trip signal drops out quickly. The trip commands can be terminated first when the last protection function has dropped out (no function is in pickup mode) AND the minimum trip signal duration has expired.

Finally, it is possible to latch the trip signal until it is manually reset (lockout function). This allows the circuit-breaker to be locked against reclosing until the cause of the fault has been clarified and the lockout has been manually reset. The reset takes place either by pressing the LED reset key or by activating an appropriately allocated binary input („>Reset LED“). A precondition, of course, is that the circuit-breaker close coil – as usual – remains blocked as long as the trip signal is present, and that the trip coil current is interrupted by the auxiliary contact of the circuit breaker.

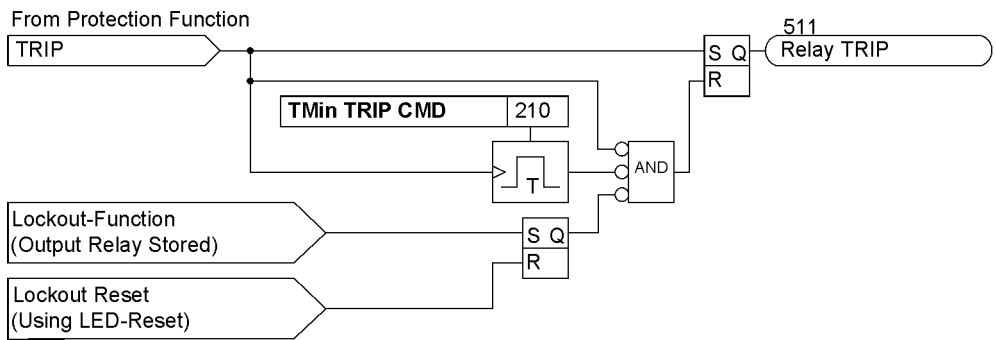

Figure 2-130 Terminating the Trip Signal

2.22.3 Setting Notes

Trip Signal Duration

The minimum trip command duration **TMin TRIP CMD** was described already in Section 2.1.3. This setting applies to all protective functions that initiate tripping.

2.23 Auxiliary Functions

The general functions of the device are described in chapter Auxiliary Functions.

2.23.1 Message Processing

After the occurrence of a system fault, information regarding the response of the protective relay and the measured values is important for a detailed analysis. An information processing function in the device takes care of this.

The procedure for allocating information is described in the SIPROTEC 4 System Description.

Applications

- LEDs and Binary Outputs
- Information via Display Field of the Device or via PC
- Information to a Control Center

Prerequisites

The SIPROTEC 4 System Description provides a detailed description of the configuration procedure (see /1/).

2.23.1.1 LEDs and Binary Outputs (Output Relays)

Important events and conditions are indicated via LEDs on the front cover. The device furthermore has output relays for remote signaling. Most of the messages and indications can be allocated, i.e. configured differently from the delivery condition. The Appendix of this manual deals in detail with the delivery condition and the allocation options.

The output relays and LEDs may be operated in a latched or unlatched mode (each may be set individually).

The latched conditions are protected against loss of the auxiliary voltage. They are reset

- locally by pressing the LED key on the relay,
- remotely using a binary input configured for that purpose,
- via one of the serial interfaces,
- automatically at the beginning of a new pickup.

Condition messages should not be latched. They also cannot be reset until the criterion to be reported is canceled. This applies, for example, to messages from monitoring functions or similar.

A green LED indicates operational readiness of the relay ("RUN"); it cannot be reset. It goes out if the self-check feature of the microprocessor recognizes an abnormal occurrence, or if the auxiliary voltage is lost.

When auxiliary voltage is present but the relay has an internal malfunction, then the red LED ("ERROR") lights up and the relay is blocked.

2.23.1.2 Information via Display Field or PC

Using the front PC interface or the port B at the bottom, a personal computer can be connected, to which the information can be sent.

The relay is equipped with several event buffers for operational messages, circuit-breaker statistics, etc., which are protected against loss of the auxiliary voltage by a buffer battery. These messages can be output on the display field at any time via the keypad or transferred to a PC via the operator interface. Readout of messages during operation is described in detail in the SIPROTEC 4 System Description.

Classification of Messages

The messages are categorized as follows:

- Operational messages (event log); messages generated while the device is operating: Information regarding the status of device functions, measured data, power system data, control command logs etc.
- Fault indications; these are indications of the last 25 network faults that were processed by the device.
- Ground fault messages (when the device has sensitive ground fault detection).
- Messages of "statistics"; they include a counter for the trip commands initiated by the device and possibly reclose commands as well as values of interrupted currents and accumulated fault currents.

A complete list of all message and output functions that can be generated by the device with the maximum functional scope can be found in the appendix. All functions are associated with an information number (FNo). There is also an indication of where each message can be sent to. If functions are not present in a not fully equipped version of the device, or are configured to **Disabled**, then the associated indications cannot appear.

Operational Messages (Buffer: Event Log)

The operational messages contain information that the device generates during operation and about operational conditions. Up to 200 operational messages are recorded in chronological order in the device. New messages are appended at the end of the list. If the memory is used up, then the oldest message is scrolled out of the list by a new message.

Fault Messages (Buffer: Trip Log)

After a fault on the system, for example, important information about the progression of the fault can be retrieved, such as the pickup of a protective element or the initiation of a trip signal. The start of the fault is time stamped with the absolute time of the internal system clock. The progress of the disturbance is output with a relative time referred to the instant of fault detection, so that the duration of the fault until tripping and up to reset of the trip command can be ascertained. The resolution of the time information is 1 ms

Spontaneous Messages on the Device Front

After occurrence of a fault, the most important fault data is output automatically on the device display, without any further operating actions. It is displayed after a general device pickup in the sequence shown in Figure 2-131.

50-1 PICKUP	Protective Function that Picked up First;
50-1 TRIP	Protective Function that Tripped Last;
T - Pickup	Operating Time from General Pickup to Dropout; (Mes.No.245)
T - TRIP	Operating Time from General Pickup to the First Trip Command; (Mes.No.246)
Fault Locator	Fault Distance in km or Miles

Figure 2-131 Display of spontaneous messages in the HMI

Retrievable Messages

The messages for the last eight network faults can be retrieved and read out. The definition of a network fault is such that the time period from fault detection up to final clearing of the disturbance is considered to be one network fault. If auto-reclosing occurs, then the network fault ends after the last reclosing shot, which means after a successful reclosing or lockout. Therefore the entire clearing process, including all reclosing shots, occupies only one trip log buffer. Within a network fault, several fault messages can occur (from the first pickup of a protective function to the last dropout of a protective function). Without auto-reclosing each fault event represents a network fault.

In total 600 indications can be recorded. Oldest data are erased for newest data when the buffer is full.

Ground Fault Messages

In devices with sensitive ground fault detection, separate ground fault logs are provided for ground fault recording. These logs are completed if the ground fault detection is not set to tripping but to **Alarm Only** (address 3101 = **Alarm Only**) or the setting **ON with GF log** has been selected. With setting **ON with GF log**, there is also a trip, apart from the opening of the ground fault log.

For $\cos\varphi / \sin\varphi$ measurements, a criterion for the opening of the ground fault log is the pickup of the VN>-Element. For „U0/I0- φ measurements“ the ground fault log is opened as soon as a VN>-Element has responded and the angle condition is fulfilled. (Detailed information is provided in the logic diagrams for ground fault detection, Section 2.12). As soon as the pickup drops out, the fault recording is terminated. The ground fault log is opened as soon as the message 1271 „Sens. Gnd Pickup“ (appearing) is issued and terminated upon disappearing of such message.

Up to 45 ground fault messages can be recorded for the last 3 ground faults. If more ground fault messages are generated, the oldest are deleted consecutively.

General Interrogation

The general interrogation which can be retrieved via DIGSI enables the current status of the SIPROTEC 4 device to be read out. All messages requiring general interrogation are displayed with their present value.

Spontaneous Messages

The spontaneous messages displayed using DIGSI reflect the present status of incoming information. Each new incoming message appears immediately, i.e. the user does not have to wait for an update or initiate one.

2.23.1.3 Information to a Control Center

Stored information can additionally be transferred to a central control and storage device if the relay is connected to such a device via port B. Transmission is possible via various transmission protocols.

2.23.2 Statistics

The number of trips initiated by the 7SJ80, the number of close commands initiated by the AR and the operating hours under load are counted. An additional counter allows the number of hours to be determined in which the circuit breaker is positioned in the „open“ condition. Further statistical data can be gained to optimize the intervals for circuit breaker maintenance.

The counter and memory levels are secured against loss of auxiliary voltage.

During the first start of the protection device the statistical values are pre-defined to zero.

2.23.2.1 Description

Number of Trips

In order to count the number of trips of 7SJ80, the 7SJ80 relay has to be informed of the position of the circuit breaker auxiliary contacts via binary inputs. Hereby, it is necessary that the internal pulse counter is allocated in the matrix to a binary input that is controlled by the circuit breaker OPEN position. The pulse count value "Number of TRIPs CB" can be found in the "Statistics" group if the option "Measured and Metered Values Only" was enabled in the configuration matrix.

Number of Automatic Reclosing Commands

The number of reclosing commands initiated by the automatic reclosing function is summed up in separate counters for the 1st and \geq 2nd cycle.

Operating Hours

The operating hours under load are also stored (= the current value in at least one phase is greater than the limit value **BkrClosed I MIN** set under address 212).

Hours Meter "CB open"

A meter can be realized as a CFC application if it adds up the number of hours in state „Circuit Breaker open“ similarly to the operating hours meter. The universal hours meter is linked to a respective binary input and counts if the binary input is active. Alternatively, the undershooting of the parameter value 212 **BkrClosed I MIN** may be used as a criterion for starting the meter. The meter can be set or reset. A CFC application example for such meter is available on the Internet (SIPROTEC Download Area).

2.23.2.2 Circuit Breaker Maintenance

General

The procedures aiding in CB maintenance allow maintenance intervals of the CB poles to be carried out when their actual degree of wear makes it necessary. Saving on maintenance and servicing costs is one of the main benefits this functionality offers.

The universal CB maintenance accumulates the tripping currents of the trips initiated by the protective functions and comprises the four following autonomous subfunctions:

- Summation tripping current (ΣI -procedure)
- Summation of tripping powers (ΣI^2 -procedure)
- Two-point procedure for calculating the remaining lifetime (2P-procedure)
- Sum of all Squared Fault Current Integral (I^2t -procedure);

Measured value acquisition and preparation operates phase-selectively for all four subfunctions. The three results are each evaluated using a threshold which is specific for each procedure (see Figure 2-132).

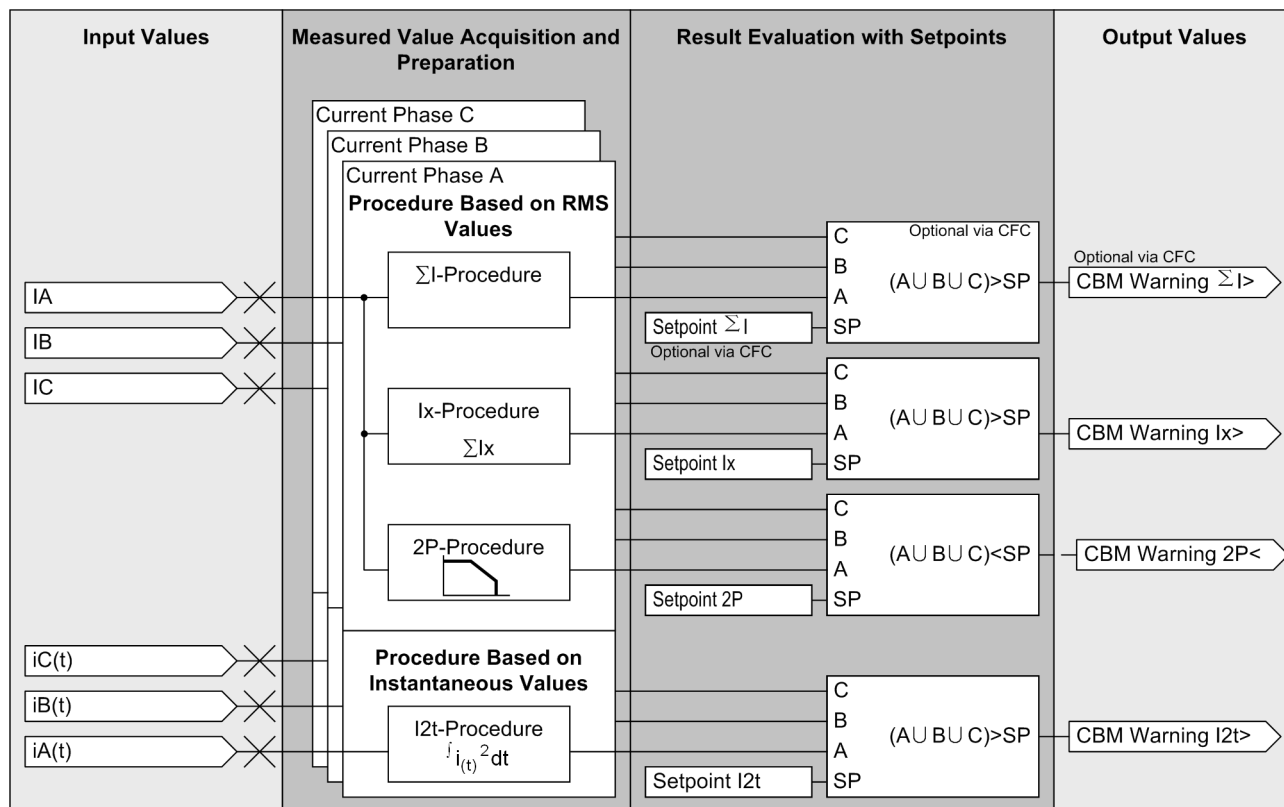

Figure 2-132 Diagram of CB maintenance procedures

The ΣI procedure is always present and active as a basic functionality. However, the other procedures (ΣI^x , 2P and I^2t) can be selected via a common configuration parameter.

As the load on the switch depends on the current amplitude and duration of the actual switching action, including arc deletion, determination of the start and end criteria is of great importance. The procedures ΣI^x , 2P and I^2t make use of the same criteria for that purpose. The logic of the start and end criterion is illustrated in Figure 2-133.

The start criterion is fulfilled by an internal protective tripping initiated by the group indication "device TRIP". Trips initiated via the internal control function are taken into consideration for the circuit breaker maintenance if the respective command is indicated via the parameter 265 **Cmd.via control**. An externally initiated trip command can be taken into consideration if the message „>52 Wear start“ is sent simultaneously via a binary input. The edge of the sent message „>52 - a“ can also be used as a further criterion as this signals that the mechanism of the circuit breaker is put in motion in order to separate the contacts.

As soon as the start criterion has been fulfilled, the parameterized opening time of the circuit breaker is started. The time of commencement of separation of the circuit breaker contacts is thus determined. The end of the trip procedure, including arc deletion is determined via another given parameter (CB tripping time) supplied by the manufacturer of the circuit breaker.

In order to prevent an incorrect calculation procedure in case of circuit breaker failure, the current criterion 212 **BkrClosed I MIN** verifies whether the current actually returned to zero after two additional cycles. When the phase-selective logic release is fulfilled by the current criterion, the calculation and evaluation methods of the respective procedures are initiated. After these have been completed, the end criterion of the circuit breaker maintenance is fulfilled and ready for a new initiation.

Please note that CB maintenance will be blocked if parameter settings are made incorrectly. This condition is indicated by the message „52 WearSet.fail“, „52WL.blk n PErr“ or „52WL.blk I PErr“ (see Section 2.1.6.2, „Power System Data 2“). The latter two indications can only take effect if the 2P-procedure was configured.

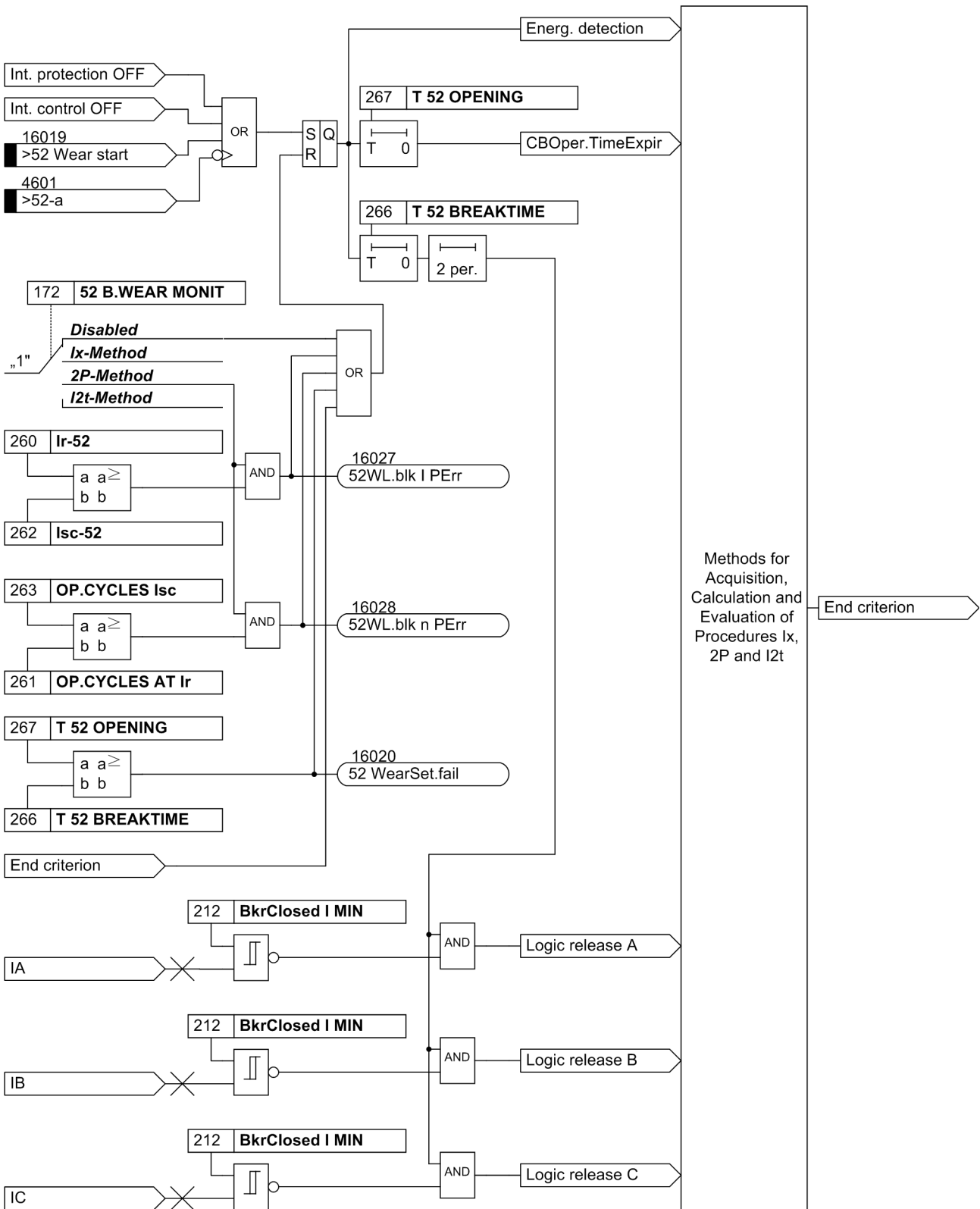

Figure 2-133 Logic of the start and end criterion

Σ I-Procedure

Being a basic function, the ΣI-procedure is unaffected by the configuration and does not require any procedure-specific settings. All tripping currents occurring 1½ periods after a protective trip, are summed up for each phase. These tripping currents are r.m.s. values of the fundamental harmonic.

The interrupted current in each pole is determined for each trip signal. The interrupted fault current is indicated in the fault messages and is added up with previously stored fault current values in the statistic-counters. Measured values are indicated in primary terms.

The ΣI method does not feature integrated threshold evaluation. But using CFC it is possible to implement a threshold, which logically combines and evaluates the three summation currents via an OR operation. Once the summation current exceeds the threshold, a corresponding message will be triggered.

Σ I^x Procedure

While the ΣI-procedure is always enabled and active, use of the ΣI^x-procedure depends on the CB maintenance configuration. This procedure operates analogously to the ΣI-procedure. The differences relate to the involution of the tripping currents and their reference to the exponentiated rated operating current of the CB. Due to the reference to I_r^x , the result is an approximation to the number of make-break operations specified by the CB manufacturer. The displayed values can be interpreted as the number of trips at rated operational current of the CB. They are displayed in the statistics values without unit and with two decimal places.

The tripping currents used for calculation are a result of the rms values of the fundamental harmonic, which is recalculated each cycle.

If the start criterion is satisfied (as described in Section „General“), the r.m.s. values, which are relevant after expiration of the opening time, are checked for each phase as to whether they comply with the current criterion. If one of the values does not satisfy the criterion, its predecessor will be used instead for calculation. If no r.m.s. value satisfies the criterion up to the predecessor of the starting point, which is marked by the start criterion, a trip has taken place which only affects the mechanical lifetime of the breaker and is consequently not detected by this procedure.

If the current criterion grants the logic release after the opening time has elapsed, the recent primary tripping currents (I_b) are involuted and related to the exponentiated rated operating current of the CB. These values are then added to the existing statistic values of the ΣI^x-procedure. Subsequently, threshold comparison is started using threshold „ΣI^x>“ as well as the output of the new related summation tripping current powers. If one of the new statistic values lies above the threshold, the message „Threshold ΣI^x>“ is generated.

2P-Procedure

The application of the two-point procedure for the calculation of the remaining lifespan depends on the CMD configuration. The data supplied by the CB manufacturer is transformed in such manner that, by means of measuring the fault currents, a concrete statement can be made with regard to the still possible operating cycles. The CB manufacturer's double-log operating cycle diagrams form the basis of the measured fault currents at the time of contact separation. Determination of the fault currents is effected in accordance with the method as described in the above section of the ΣI^x-procedure.

The three results of the calculated remaining lifetime are represented as statistic value. The results represent the number of still possible trips, if the tripping takes place when the current reaches the rated operational current. They are displayed without unit and without decimals.

As with the other procedures, a threshold logically combines the three „remaining lifetime results“ via an OR operation and evaluates them. It forms the „lower threshold“, since the remaining lifetime is decremented with each trip by the corresponding number of operating cycles. If one of the three phase values drops below the threshold, a corresponding message will be triggered.

A double-logarithmic diagram provided by the CB manufacturer illustrates the relationship of operating cycles and tripping current (see example in Figure 2-134). This diagram allows the number of yet possible trips to be determined (for tripping with equal tripping current). According to the example, approximately 1000 trips can

yet be carried out at a tripping current of 10 kA. The characteristic is determined by two vertices and their connecting line. Point P1 is determined by the number of permitted operating cycles at rated operating current I_r , point P2 by the maximum number of operating cycles at rated fault tripping current I_{sc} . The associated four values can be configured.

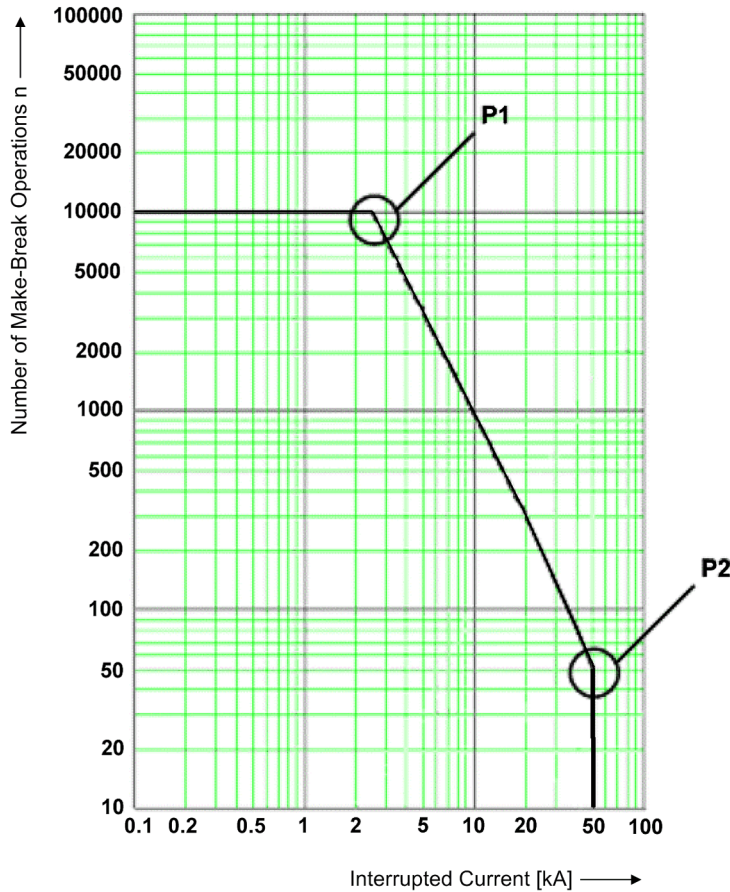

Figure 2-134 Diagram of operating cycles for the 2P procedure

As Figure 2-134 illustrates a double-log diagram, the straight line between P1 and P2 can be expressed by the following exponential function:

$$n = b \cdot I_b^m$$

where n is the number of operating cycles, b the operating cycles at $I_b = 1A$, I_b the tripping current, and m the directional coefficient.

The general line equation for the double-logarithmic representation can be derived from the exponential function and leads to the coefficients b and m .



Note

Since a directional coefficient of $m < -4$ is technically irrelevant, but could theoretically be the result of incorrect settings, it is limited to -4 . If a coefficient is smaller than -4 , the exponential function in the operating cycles diagram is deactivated. The maximum number of operating cycles with I_{sc} (**263 OP.CYCLES I_{sc}**) is used instead as the calculation result for the current number of operating cycles, see Figure 2-135.

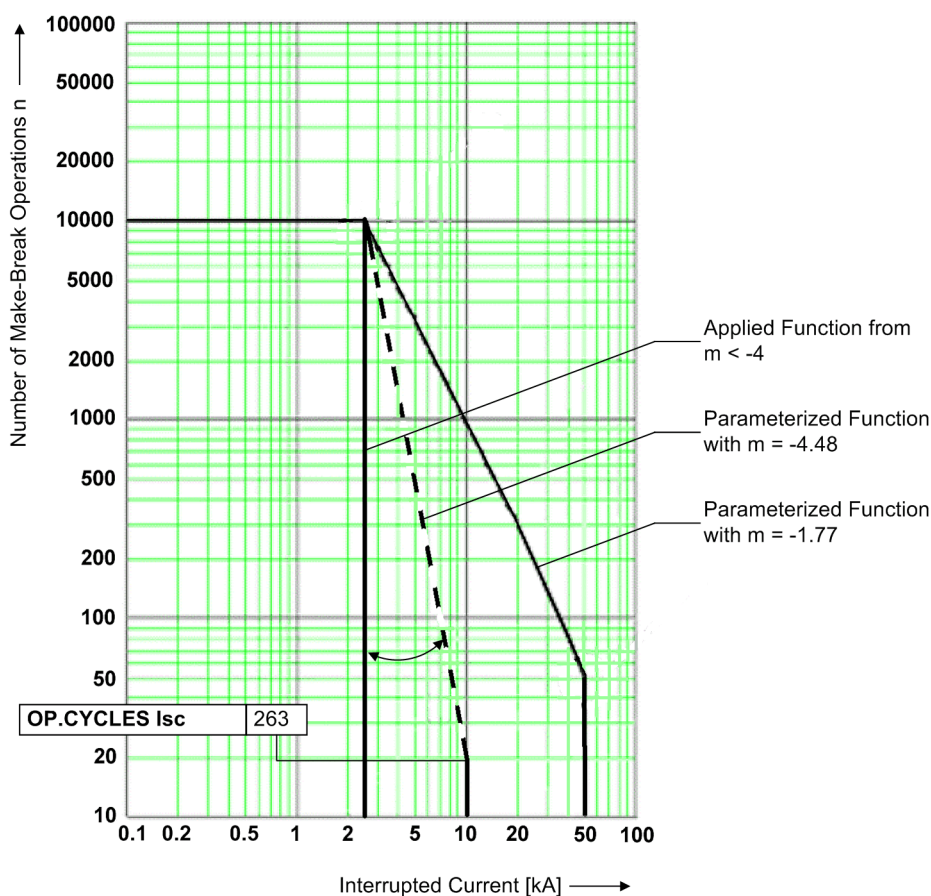

Figure 2-135 Value limitation of directional coefficient

If the current criterion described in the Section „General“ grants the phase-selective logic release, the present number of operating cycles is calculated based on the tripping currents determined when the CB operating time on tripping has elapsed. They are set off against the remaining lifetime allowing the present statistic values to be displayed and the evaluation to be started using the specified threshold. If one of the new values lies above the threshold, the message „Thresh . R . Endu . <“ is generated.

Three additional phase-selective statistic values are provided to determine the portion of purely mechanical trips among the results of the remaining lifetime (e.g. for phase A: „mechan . TRIP A=“). They act as counters which count only the trips whose tripping currents are below the value of the current criterion.

I²t-Procedure

During the I²t-procedure the squared fault current integral occurring per trip is added up phase-selectively. The integral is derived from the squared instantaneous values of the currents occurring during arc time of the circuit breaker. This results in:

$$T_{CB \text{ arc}} = (\text{parameter } 266 \text{ T } 52 \text{ BREAKTIME}) - (\text{parameter } 267 \text{ T } 52 \text{ OPENING}).$$

The three sums of the calculated integrals are represented as statistic values referred to the squared device nominal current (I_{nom}^2). As with the other procedures, a threshold logically combines the three sums via an OR operation and evaluates them.

The calculated squared tripping current integrals are added to the existing statistic values. Subsequently, threshold comparison is started using threshold „ $\Sigma I^2 t >$ “, and the new statistic values are output. If one of the values lies above the threshold, the message „Thresh . $\Sigma I^2 t >$ “ is generated.

Commissioning

Usually, no measures are required for commissioning. However, should the protection device be exchanged (e.g. old circuit breaker and a new protection device), the initial values of the respective limit or statistical values must be determined via the switching statistics of the respective circuit breaker.

2.23.2.3 Setting Notes

Reading/Setting/Resetting Counters

The SIPROTEC 4 System Description provides a description of how to read out the statistical counters via the device front panel or DIGSI. Setting or resetting of these statistical counters takes place under the menu item **MESSAGES** → **STATISTICS** by overwriting the counter values displayed.

Circuit Breaker Maintenance

Under address 172 **52 B.WEAR MONIT** one of the alternatives ΣI^x procedure, 2P procedure, I^2t procedure or **Disabled** can be set. All parameters relevant to this function are available at parameter block **P.System Data 1** (see Section 2.1.3).

The following setting values are important input values the subfunctions require in order to operate correctly:

The CB Tripping Time is a characteristic value provided by the manufacturer. It covers the entire tripping process from the trip command (applying auxiliary power to the trip element of the circuit breaker) up to arc extinction in all poles. The time is set at address 266 **T 52 BREAKTIME**.

The CB Operating Time **T 52 OPENING** is equally a characteristic value of the circuit breaker. It covers the time span between the trip command (applying auxiliary power to the trip element of the circuit breaker) and separation of CB contacts in all poles. It is entered at address 267 **T 52 OPENING**.

The following diagram illustrates the relationship between these CB times.

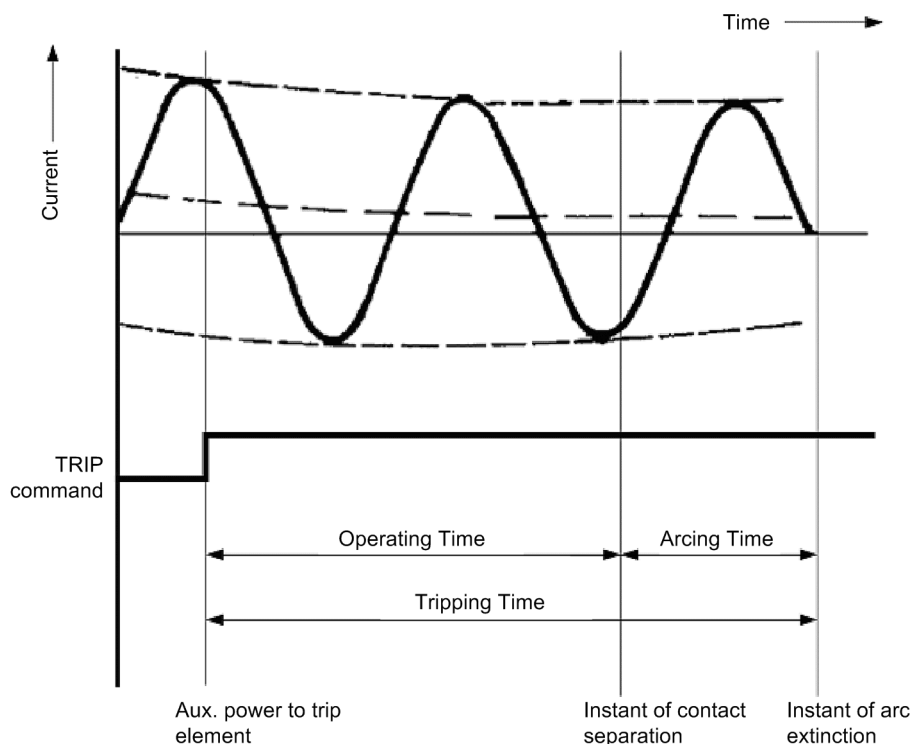

Figure 2-136 Illustration of the CB times

Current flow monitoring 212 **BkrClosed I MIN**, which some protective functions rely upon to detect a closed CB, is used as the current zero criterion. It should be set with respect to the actually used device functions (see also margin heading „Current Flow Monitoring (CB)“ in Section 2.1.3.2.

ΣI Procedure

Being the basic function of summation current formation, the ΣI -procedure is always active and does not require any additional settings. This is irrespective of the configuration in address 172 **52 B.WEAR MONIT**. This method does not offer integrated threshold evaluation. The latter could, however, be implemented using CFC.

ΣI^x Procedure

Parameter 172 **52 B.WEAR MONIT** can be set to activate the ΣI^x procedure. In order to facilitate evaluating the sum of all tripping current powers, the values are referred to the involuted CB rated operational current. This value is indicated in the CB data at address 260 **Ir-52** in the **P.System Data 1** and can be set as primary value. This reference allows the threshold of the ΣI^x procedure to correspond to the maximum number of make-break operations. For a circuit breaker, whose contacts have not yet been worn, the maximum number of make-break operations can be entered directly as threshold. The exponent for the involution of the rated operational current and of the tripping currents is set at address 264 **Ix EXPONENT**. To meet different customer requirements, this exponent 264 **Ix EXPONENT** can be increased from **1.0** (default setting = **2.0**) to **3.0**.

For the procedure to operate correctly, the time response of the circuit breaker must be specified in parameters 266 **T 52 BREAKTIME** and 267 **T 52 OPENING**.

The summated values can be interpreted as the number of tripping operations at rated operational current of the CB. They are displayed in the statistical values without unit and with two decimal places.

2P-Procedure

Parameter 172 **52 B.WEAR MONIT** can be set to activate the 2P procedure. An operating cycles diagram (see sample diagram in the functional description of the 2P procedure), provided by the manufacturer, shows the relationship of make-break operations and tripping current. The two vertices of this characteristic in a double logarithmic scale are decisive for the setting of addresses 260 to 263:

Point P1 is determined by the number of permitted make-break operations (parameter 261 **OP.CYCLES AT Ir**) for rated operational current I_r (parameter 260 **Ir-52**)

Point P2 is determined by the maximum number of make-break operations (parameter 263 **OP.CYCLES I_{sc}**) for rated fault tripping current I_{sc} (parameter 262 **I_{sc}-52**).

For the procedure to operate correctly, the time response of the circuit breaker must be specified in parameters 266 **T 52 BREAKTIME** and 267 **T 52 OPENING**.

I²t-Procedure

The I²t-procedure is activated via configuration parameter 172 **52 B.WEAR MONIT**. The square fault current integrals are referred to the squared device nominal current. For purposes of determining the arc time, the device must be informed of the CB tripping time **T 52 BREAKTIME** as well as the CB opening time **T 52 OPENING** of the circuit breaker. For recognition of the last zero crossing (arc deletion) of the currents after tripping, the „Current-zero“ Criterion is required.

2.23.2.4 Information List

No.	Information	Type of Information	Comments
-	#of TRIPs=	PMV	Number of TRIPs=
409	>BLOCK Op Count	SP	>BLOCK Op Counter
1020	Op.Hours=	VI	Counter of operating hours
1021	$\Sigma I_a =$	VI	Accumulation of interrupted current Ph A
1022	$\Sigma I_b =$	VI	Accumulation of interrupted current Ph B
1023	$\Sigma I_c =$	VI	Accumulation of interrupted current Ph C
2896	79 #Close1./3p=	VI	No. of 1st AR-cycle CLOSE commands,3pole
2898	79 #Close2./3p=	VI	No. of higher AR-cycle CLOSE commands,3p
16001	$\Sigma I^x A=$	VI	Sum Current Exponentiation Ph A to I_r^x
16002	$\Sigma I^x B=$	VI	Sum Current Exponentiation Ph B to I_r^x
16003	$\Sigma I^x C=$	VI	Sum Current Exponentiation Ph C to I_r^x
16006	Resid.Endu. A=	VI	Residual Endurance Phase A
16007	Resid.Endu. B=	VI	Residual Endurance Phase B
16008	Resid.Endu. C=	VI	Residual Endurance Phase C
16011	mechan.TRIP A=	VI	Number of mechanical Trips Phase A
16012	mechan.TRIP B=	VI	Number of mechanical Trips Phase B
16013	mechan.TRIP C=	VI	Number of mechanical Trips Phase C
16014	$\Sigma I^2t A=$	VI	Sum Squared Current Integral Phase A
16015	$\Sigma I^2t B=$	VI	Sum Squared Current Integral Phase B
16016	$\Sigma I^2t C=$	VI	Sum Squared Current Integral Phase C

2.23.3 Measurement

A series of measured values and the values derived from them are constantly available for call up on site, or for data transfer.

Applications

- Information on the actual status of the system
- Conversion of secondary values to primary values and percentages

Prerequisites

Except for secondary values, the device is able to indicate the primary values and percentages of the measured values.

A precondition correct display of the primary and percentage values is the complete and correct entry of the nominal values for the instrument transformers and the protected equipment as well as current and voltage transformer ratios in the ground paths when configuring the device. The following table shows the formulas which are the basis for the conversion of secondary values to primary values and percentages.

When using the capacitive voltage connection, or with the connection types **Vab**, **Vbc** or **Vab**, **Vbc**, **VSyn** or **Vab**, **Vbc**, **Vx** or **Vph-g**, **VSyn** of the voltage transformers (address 213 **VT Connect. 3ph**), the measured values for power P, Q, S, power factor, energy and the derived values, such as mean values etc. are not available.

Measured values which cannot be calculated due to the selected voltage connection are shown as dots.

2.23.3.1 Display of Measured Values

Table 2-24 Conversion formulae between secondary, primary and percentage values

Measured values	Secondary	Primary	%
$I_A, I_B, I_C,$ I_1, I_2	$I_{sec.}$	$\frac{CT PRIM}{CT SEC} \cdot I_{sec}$	$\frac{I_{prim}}{FullScaleCurr.}$
$I_N = 3 \cdot I_0$ (calculated)	$I_{N sec.}$	$\frac{CT PRIM}{CT SEC} \cdot I_{n sec}$	$\frac{I_{Nom prim}}{FullScaleCurr.}$
$I_N =$ measured value of I_N input	$I_{N sec.}$	$\frac{IN CT PRIM}{IN CT SEC} \cdot I_{N sec}$	$\frac{I_{Nom prim}}{FullScaleCurr.}$
I_{Ns} ($I_{Ns_rms},$ $I_{Ns_active},$ $I_{Ns_reactive}$)	$I_{Ns sec.}$	$\frac{IN CT PRIM}{IN CT SEC} \cdot I_{Ns sec}$	$\frac{I_{Ns prim}}{FullScaleCurr.}$
$I_{N2} =$ measured value of I_{N2} input	$I_{N2 sec.}$	$\frac{IB-CT PRIM}{IB-CT SEC} \cdot I_{e sec}$	$\frac{I_{Nom prim}}{FullScaleCurr.}$
$V_A, V_B, V_C,$ $V_0, V_1, V_2,$ V_{syn}	$V_{ph-n sec.}$	$\frac{Vnom PRIMARY}{Vnom SECONDARY} \cdot U_{PhNsec}$	$\frac{V_{prim}}{FullScaleVolt. / (\sqrt{3})}$
$V_{A-B}, V_{B-C}, V_{C-A}$	$V_{ph-ph sec.}$	$\frac{Vnom PRIMARY}{Vnom SECONDARY} \cdot V_{Ph-Ph sec}$	$\frac{V_{prim}}{FullScaleVolt.}$
V_N	$V_{N sec.}$	$V_{ph/Vdelta} \cdot \frac{Vnom PRIM}{Vnom SEC} \cdot V_{N sec}$	$\frac{V_{prim}}{\sqrt{3} \cdot FullScaleVolt.}$

Measured values	Secondary	Primary	%
V_x	$V_{x \text{ sec.}}$	$\frac{VXnom \text{ PRIMARY}}{VXnom \text{ SECONDARY}} \cdot V_x$	$\frac{V_{prim}}{V \text{ REF } 100\% \text{ PRIM}}$
P, Q, S (P and Q phase-segregated)	No secondary measured values		$\frac{Power_{prim}}{\sqrt{3} \cdot (\text{Full.Scal.Volt.}) \cdot (\text{Full.Scal.Curr.})}$
Power factor (phase-segregated)	$\cos \varphi$	$\cos \varphi$	$\cos \varphi \cdot 100 \text{ in } \%$
Frequency	f in Hz	f in Hz	$\frac{f \text{ in Hz}}{f_{Nom}} \cdot 100$

Table 2-25 Legend for the conversion formulae

Parameter	Address	Parameter	Address
Vnom PRIMARY	202	Ignd-CT PRIM	217
Vnom SECONDARY	203	Ignd-CT SEC	218
CT PRIMARY	204	Ignd2-CT PRIM.	238
CT SECONDARY	205	Ignd2-CT SEC.	239
Vph / Vdelta	206	FullScaleVolt.	1101
VXnom PRIMARY	232	FullScaleCurr.	1102
VXnom SECONDARY	233		

Depending on the type of device ordered and the device connections, some of the operational measured values listed below may not be available. The phase-to-Ground voltages are either measured directly, if the voltage inputs are connected phase-to-Ground, or they are calculated from the phase-to-phase voltages V_{A-B} and V_{B-C} and the displacement voltage V_N .

The displacement voltage V_N is either measured directly or calculated from the phase-to-Ground voltages:

$$V_N = \frac{3 \cdot V_0}{\sqrt{V_{ph}} / \sqrt{V_{delta}}} \quad \text{with} \quad \begin{aligned} 3V_0 &= (V_{A-G} + V_{B-G} + V_{C-G}) \\ V_{ph} / V_{delta} &= \text{Transformation adjustment for ground input voltage (setting 0206A)} \end{aligned}$$

Please note that value V_0 is indicated in the operational measured values.

The ground current I_N is either measured directly or calculated from the conductor currents.

$$I_N = \frac{3 \cdot I_0}{I_{gnd-CT} / (CT)} \quad \text{with} \quad \begin{aligned} 3I_0 &= (I_A + I_B + I_C) \\ I_{gnd-CT} &= \text{setting 0217 or 0218} \\ CT &= \text{setting 0204 or 0205} \end{aligned}$$

Upon delivery, the power and operating values are set in such manner that power in line direction is positive. Active components in line direction and inductive reactive components in line direction are also positive. The same applies to the power factor $\cos \varphi$. It is occasionally desired to define the power drawn from the line (e.g. as seen from the consumer) positively. Using parameter 1108 **P, Q sign** the signs for these components can be inverted.

The calculation of the operational measured values also takes place while a fault is running. The values are updated at intervals of > 0.3 s and < 1 s.

2.23.3.2 Transmitting Measured Values

Measured values can be transferred to a central control and storage device via port B.

The measuring range in which these values are transmitted depend on the protocol and, if necessary, additional settings.

Protocol	Transmittable measuring range, format
IEC 60870–5–103	0 to 240 % of the measured value.
IEC 61850	The primary operational measured values are transmitted. The measured values as well as their unit format are set out in detail in manual PIXIT 7SJ. The measured values are transmitted in „Float“ format. The transmitted measuring range is not limited and corresponds to the operational measurement.
PROFIBUS, Modbus, DNP 3.0 DNP3 TCP PROFINET	The unit format of the measured values on the device side is at first automatically generated by means of the selected nominal values of current and voltage within the system data. The current unit format can be determined in DIGSI or at the device via Menu Operational Values. The user can select via DIGSI which operational measured values (primary, secondary or percentage) must be transmitted. The measured values are always transmitted as 16-bit values including sign (range ± 32768). The user can define the scaling of the operational measured value to be transmitted. This will result in the respective transmittable measuring range. For further details, please refer to the descriptions and protocol profiles.

2.23.3.3 Information List

No.	Information	Type of Information	Comments
601	Ia =	MV	Ia
602	Ib =	MV	Ib
603	Ic =	MV	Ic
604	In =	MV	In
605	I1 =	MV	I1 (positive sequence)
606	I2 =	MV	I2 (negative sequence)
621	Va =	MV	Va
622	Vb =	MV	Vb
623	Vc =	MV	Vc
624	Va-b=	MV	Va-b
625	Vb-c=	MV	Vb-c
626	Vc-a=	MV	Vc-a
627	VN =	MV	VN
629	V1 =	MV	V1 (positive sequence)
630	V2 =	MV	V2 (negative sequence)
632	Vsync =	MV	Vsync (synchronism)
641	P =	MV	P (active power)
642	Q =	MV	Q (reactive power)
644	Freq=	MV	Frequency
645	S =	MV	S (apparent power)
680	Phi A =	MV	Angle Va-Ia

No.	Information	Type of Information	Comments
681	Phi B =	MV	Angle Vb-Ib
682	Phi C =	MV	Angle Vc-Ic
701	INs Real	MV	Resistive ground current in isol systems
702	INs Reac	MV	Reactive ground current in isol systems
807	Θ/Θ_{trip}	MV	Thermal Overload
830	INs =	MV	INs Sensitive Ground Fault Current
831	3I ₀ =	MV	3I ₀ (zero sequence)
832	V ₀ =	MV	V ₀ (zero sequence)
901	PF =	MV	Power Factor
16031	$\varphi(3V_0, I_{Ns}) =$	MV	Angle between 3V ₀ and I _{Ns} ens.
30701	P _a =	MV	P _a (active power, phase A)
30702	P _b =	MV	P _b (active power, phase B)
30703	P _c =	MV	P _c (active power, phase C)
30704	Q _a =	MV	Q _a (reactive power, phase A)
30705	Q _b =	MV	Q _b (reactive power, phase B)
30706	Q _c =	MV	Q _c (reactive power, phase C)
30707	PF _a =	MV	Power Factor, phase A
30708	PF _b =	MV	Power Factor, phase B
30709	PF _c =	MV	Power Factor, phase C
30800	V _X =	MV	Voltage V _X
30801	V _{ph-n} =	MV	Voltage phase-neutral

2.23.4 Average Measurements

The long-term averages are calculated and output by the 7SJ80.

2.23.4.1 Description

Long-Term Averages

The long-term averages of the three phase currents I_x , the positive sequence components I_1 for the three phase currents, and the real power P, reactive power Q, and apparent power S are calculated within a set period of time and indicated in primary values.

For the long-term averages mentioned above, the length of the time window for averaging and the frequency with which it is updated can be set.

2.23.4.2 Setting Notes

Average Calculation

The selection of the time period for measured value averaging is set with parameter 8301 **DMD Interval** in the corresponding setting group from A to D under **MEASUREMENT**. The first number specifies the averaging time window in minutes while the second number gives the frequency of updates within the time window. **15 Min., 3 Subs**, for example, means: Time average is generated for all measured values with a window of 15 minutes. The output is updated every $15/3 = 5$ minutes.

With address 8302 **DMD Sync.Time**, the starting time for the averaging window set under address 8301 is determined. This setting specifies if the window should start on the hour (**On The Hour**) or 15 minutes later (**15 After Hour**) or 30 minutes / 45 minutes after the hour (**30 After Hour, 45 After Hour**).

If the settings for averaging are changed, then the measured values stored in the buffer are deleted, and new results for the average calculation are only available after the set time period has passed.

2.23.4.3 Settings

Addr.	Parameter	Setting Options	Default Setting	Comments
8301	DMD Interval	15 Min., 1 Sub 15 Min., 3 Subs 15 Min., 15 Subs 30 Min., 1 Sub 60 Min., 1 Sub 60 Min., 10 Subs 5 Min., 5 Subs	60 Min., 1 Sub	Demand Calculation Intervals
8302	DMD Sync.Time	On The Hour 15 After Hour 30 After Hour 45 After Hour	On The Hour	Demand Synchronization Time

2.23.4.4 Information List

No.	Information	Type of Information	Comments
833	I1 dmd=	MV	I1 (positive sequence) Demand
834	P dmd =	MV	Active Power Demand
835	Q dmd =	MV	Reactive Power Demand
836	S dmd =	MV	Apparent Power Demand
963	Ia dmd=	MV	I A demand
964	Ib dmd=	MV	I B demand
965	Ic dmd=	MV	I C demand

2.23.5 Min/Max Measurement Setup

Minimum and maximum values are calculated by the 7SJ80. Time and date of the last update of the values can also be read out.

2.23.5.1 Description

Minimum and Maximum Values

The minimum and maximum values for the three phase currents I_x , the three phase voltages V_{x-N} , the phase-to-phase voltages V_{xy} , the positive sequence component I_1 and V_1 , the voltage V_N , the active power P, reactive power Q, and apparent power S, the frequency, and the power factor $\cos \varphi$ primary values are formed including the date and time they were last updated.

The minimum and maximum values of the long-term averages listed in the previous section are also calculated.

The minimum and maximum values can be reset at any time via binary inputs or by using the integrated control panel or the DIGSI software. Additionally, the reset can be carried out cyclically, starting at a preset point of time.

2.23.5.2 Setting Notes

Minimum and Maximum Values

The tracking of minimum and maximum values can be reset automatically at a programmable point in time. To select this feature, address 8311 **MinMax cycRESET** should be set to **YES**. The point in time when reset is to take place (the minute of the day in which reset will take place) is set at address 8312 **MiMa RESET TIME**. The reset cycle in days is entered at address 8313 **MiMa RESETCYCLE**, and the beginning date of the cyclical process, from the time of the setting procedure (in days), is entered at address 8314 **MinMaxRES.START**.

2.23.5.3 Settings

Addr.	Parameter	Setting Options	Default Setting	Comments
8311	MinMax cycRESET	NO YES	YES	Automatic Cyclic Reset Function
8312	MiMa RESET TIME	0 .. 1439 min	0 min	MinMax Reset Timer
8313	MiMa RESETCYCLE	1 .. 365 Days	7 Days	MinMax Reset Cycle Period
8314	MinMaxRES.START	1 .. 365 Days	1 Days	MinMax Start Reset Cycle in

2.23.5.4 Information List

No.	Information	Type of Information	Comments
-	ResMinMax	IntSP_Ev	Reset Minimum and Maximum counter
395	>I MinMax Reset	SP	>I MIN/MAX Buffer Reset
396	>I1 MiMaReset	SP	>I1 MIN/MAX Buffer Reset
397	>V MiMaReset	SP	>V MIN/MAX Buffer Reset
398	>VphphMiMaRes	SP	>Vphph MIN/MAX Buffer Reset

No.	Information	Type of Information	Comments
399	>V1 MiMa Reset	SP	>V1 MIN/MAX Buffer Reset
400	>P MiMa Reset	SP	>P MIN/MAX Buffer Reset
401	>S MiMa Reset	SP	>S MIN/MAX Buffer Reset
402	>Q MiMa Reset	SP	>Q MIN/MAX Buffer Reset
403	>Idmd MiMaReset	SP	>Idmd MIN/MAX Buffer Reset
404	>Pdmd MiMaReset	SP	>Pdmd MIN/MAX Buffer Reset
405	>Qdmd MiMaReset	SP	>Qdmd MIN/MAX Buffer Reset
406	>Sdmd MiMaReset	SP	>Sdmd MIN/MAX Buffer Reset
407	>Frq MiMa Reset	SP	>Frq. MIN/MAX Buffer Reset
408	>PF MiMaReset	SP	>Power Factor MIN/MAX Buffer Reset
412	> θ MiMa Reset	SP	>Theta MIN/MAX Buffer Reset
837	IAdmdMin	MVT	I A Demand Minimum
838	IAdmdMax	MVT	I A Demand Maximum
839	IBdmdMin	MVT	I B Demand Minimum
840	IBdmdMax	MVT	I B Demand Maximum
841	ICdmdMin	MVT	I C Demand Minimum
842	ICdmdMax	MVT	I C Demand Maximum
843	I1dmdMin	MVT	I1 (positive sequence) Demand Minimum
844	I1dmdMax	MVT	I1 (positive sequence) Demand Maximum
845	PdMin=	MVT	Active Power Demand Minimum
846	PdMax=	MVT	Active Power Demand Maximum
847	QdMin=	MVT	Reactive Power Minimum
848	QdMax=	MVT	Reactive Power Maximum
849	SdMin=	MVT	Apparent Power Minimum
850	SdMax=	MVT	Apparent Power Maximum
851	Ia Min=	MVT	Ia Min
852	Ia Max=	MVT	Ia Max
853	Ib Min=	MVT	Ib Min
854	Ib Max=	MVT	Ib Max
855	Ic Min=	MVT	Ic Min
856	Ic Max=	MVT	Ic Max
857	I1 Min=	MVT	I1 (positive sequence) Minimum
858	I1 Max=	MVT	I1 (positive sequence) Maximum
859	Va-nMin=	MVT	Va-n Min
860	Va-nMax=	MVT	Va-n Max
861	Vb-nMin=	MVT	Vb-n Min
862	Vb-nMax=	MVT	Vb-n Max
863	Vc-nMin=	MVT	Vc-n Min
864	Vc-nMax=	MVT	Vc-n Max
865	Va-bMin=	MVT	Va-b Min
867	Va-bMax=	MVT	Va-b Max
868	Vb-cMin=	MVT	Vb-c Min
869	Vb-cMax=	MVT	Vb-c Max
870	Vc-aMin=	MVT	Vc-a Min
871	Vc-aMax=	MVT	Vc-a Max
872	Vn Min =	MVT	V neutral Min

No.	Information	Type of Information	Comments
873	Vn Max =	MVT	V neutral Max
874	V1 Min =	MVT	V1 (positive sequence) Voltage Minimum
875	V1 Max =	MVT	V1 (positive sequence) Voltage Maximum
876	Pmin=	MVT	Active Power Minimum
877	Pmax=	MVT	Active Power Maximum
878	Qmin=	MVT	Reactive Power Minimum
879	Qmax=	MVT	Reactive Power Maximum
880	Smin=	MVT	Apparent Power Minimum
881	Smax=	MVT	Apparent Power Maximum
882	fmin=	MVT	Frequency Minimum
883	fmax=	MVT	Frequency Maximum
884	PF Max=	MVT	Power Factor Maximum
885	PF Min=	MVT	Power Factor Minimum
1058	⊖/⊖TrpMax=	MVT	Overload Meter Max
1059	⊖/⊖TrpMin=	MVT	Overload Meter Min

2.23.6 Set Points for Measured Values

SIPROTEC devices facilitate the setting of limit values for some measured and metered values. If any of these limit values is reached, exceeded or fallen below during operation, the device issues an alarm which is indicated in the form of an operational message. This can be allocated to LEDs and/or binary outputs, transferred via the interfaces and linked in DIGSI CFC. The limit values can be configured via DIGSI CFC and allocated via the DIGSI device matrix.

Applications

- This monitoring program works with multiple measurement repetitions and a lower priority than the protection functions. Therefore, it may not pick up if measured values are changed spontaneously in the event of a fault, before a pickup or tripping of the protection function occurs. This monitoring program is therefore absolutely unsuitable for blocking protection functions.

2.23.6.1 Setting Notes

Setpoints for Measured Values

Setting is performed in the DIGSI configuration Matrix under **Settings, Masking I/O (Configuration Matrix)**. Apply the filter "Measured and Metered Values Only" and select the configuration group "Set Points (MV)".

Here you can insert new limit values via the Information Catalog which are subsequently linked to the measured value to be monitored using CFC.

This view also allows you to change the default settings of the limit values under **Properties**.

The settings for limit values must be in percent and usually refer to nominal values of the device.

For more details, see the SIPROTEC 4 System Description and the DIGSI CFC Manual.

2.23.7 Set Points for Statistic

2.23.7.1 Description

For the statistical counters, limit values may be entered so that a message is generated as soon as they are reached. These messages can be allocated to both output relays and LEDs.

2.23.7.2 Setting Notes

Limit Values for the Statistics Counter

The limit values for the statistics counters can be set in DIGSI under **Annunciation** → **Statistic** in the sub-menu **Statistics**. Double-click to display the corresponding contents in new window. By overwriting the previous value, a new value can be entered (see also SIPROTEC 4 System Description).

2.23.7.3 Information List

No.	Information	Type of Information	Comments
-	OpHour>	LV	Operating hours greater than
272	SP. Op Hours>	OUT	Set Point Operating Hours
16004	$\Sigma I^x >$	LV	Threshold Sum Current Exponentiation
16005	Threshold $\Sigma I^x >$	OUT	Threshold Sum Curr. Exponent. exceeded
16009	Resid.Endu. <	LV	Lower Threshold of CB Residual Endurance
16010	Thresh.R.Endu.<	OUT	Dropped below Threshold CB Res.Endurance
16017	$\Sigma I^2 t >$	LV	Threshold Sum Squared Current Integral
16018	Thresh. $\Sigma I^2 t >$	OUT	Threshold Sum Squa. Curr. Int. exceeded

2.23.8 Energy Metering

Metered values for active and reactive energy are determined by the device. They can be output via the display of the device, read out with DIGSI via the operator interface or transmitted to a control center via port B.

2.23.8.1 Description

Metered Values for Active and Reactive Energy

Metered values of the real power W_p and reactive power (W_q) are acquired in kilowatt, megawatt or gigawatt hours primary or in kVARh, MVARh or GVARh primary, separately according to the input (+) and output (-), or capacitive and inductive. The measured-value resolution can be configured. The signs of the measured values appear as configured in address 1108 **P, Q sign** (see Section „Display of Measured Values“).

2.23.8.2 Setting Notes

Setting of parameter for meter resolution

Parameter 8315 **MeterResolution** allows increasing the resolution of the energy metered values by the **Factor 10** or **Factor 100** compared to the **Standard** setting.

2.23.8.3 Settings

Addr.	Parameter	Setting Options	Default Setting	Comments
8315	MeterResolution	Standard Factor 10 Factor 100	Standard	Meter resolution

2.23.8.4 Information List

No.	Information	Type of Information	Comments
-	Meter res	IntSP_Ev	Reset meter
888	Wp(puls)	PMV	Pulsed Energy Wp (active)
889	Wq(puls)	PMV	Pulsed Energy Wq (reactive)
916	WpΔ=	-	Increment of active energy
917	WqΔ=	-	Increment of reactive energy
924	WpForward	MVMV	Wp Forward
925	WqForward	MVMV	Wq Forward
928	WpReverse	MVMV	Wp Reverse
929	WqReverse	MVMV	Wq Reverse

2.23.9 Commissioning Aids

In test mode or during commissioning, the device information transmitted to a central or storage device can be influenced. There are tools available for testing the system interface (port B) and the binary inputs and outputs of the device.

Applications

- Test Mode
- Commissioning

Prerequisites

In order to be able to use the commissioning aids described in the following, the device must be connected to a control center via port B.

2.23.9.1 Description

Influencing Information to the Control Center During Test Mode

Some of the available protocols allow for identifying all messages and measured values transmitted to the control center with "test mode" as the message cause while the device is tested on site. This identification prevents the message from being incorrectly interpreted as resulting from an actual fault. Moreover, a transmission block can be set during the test so that no messages are transferred to the control center.

This can be implemented via binary inputs, using the interface on the device front and a PC.

The SIPROTEC 4 System Description states in detail how to activate and deactivate test mode and blocked data transmission.

Testing the Connection to a Control Center

Via the DIGSI device control it can be tested whether messages are transmitted correctly.

A dialog box shows the display texts of all messages which were allocated to the system interface (port B) in the DIGSI matrix. In another column of the dialog box, a value for the messages to be tested can be defined (e.g. message ON / message OFF). After having entered password no. 6 (for hardware test menus), the corresponding message is issued and can be read out in the event log of the SIPROTEC 4 device and in the substation control center.

The procedure is described in detail in Chapter "Mounting and Commissioning".

Checking the Binary Inputs and Outputs

The binary inputs, outputs, and LEDs of a SIPROTEC 4 device can be individually and precisely controlled in DIGSI. This feature can be used, for example, to verify control wiring from the device to substation equipment (operational checks), during start-up.

A dialog box shows all binary inputs and outputs as well as LEDs of the device with their present status. The operating equipment, commands, or messages that are configured (masked) to the hardware components are also displayed. After having entered password no. 6 (for hardware test menus), it is possible to switch to the opposite status in another column of the dialog box. Thus, you can energize every single output relay to check the wiring between protected device and the system without having to create the alarm allocated to it.

The procedure is described in detail in Chapter "Mounting and Commissioning".

Creating Oscillographic Recordings for Tests

During commissioning, energization sequences should be carried out to check the stability of the protection also during closing operations. Oscillographic event recordings contain the maximum information on the behavior of the protection.

Along with the capability of storing fault recordings via pickup of the protection function, the 7SJ80 also has the capability of capturing the same data when commands are given to the device via the service program DIGSI, the serial interface, or a binary input. For the latter, event „>Trig.Wave.Cap.“ must be allocated to a binary input. Triggering for the oscillographic recording then occurs, for instance, via the binary input when the protection object is energized.

An oscillographic recording that is triggered externally (that is, without a protective element pickup) are processed by the device as a normal oscillographic record. For each oscillographic record a fault record is created which is given its individual number to ensure that assignment can be made properly. However, these oscillographic recordings are not displayed in the fault log buffer in the display as they are no network fault events.

The procedure is described in detail in Chapter "Mounting and Commissioning".

2.24 Breaker Control

A control command function is integrated in the SIPROTEC 4 7SJ80 to coordinate the operation of circuit breakers and other equipment in the power system.

Control commands can originate from four command sources:

- Local control at the device's operator panel
- Operation using DIGSI
- Remote control via network control center or substation controller (e.g. SICAM)
- Automatic functions (e.g., via binary input)

Switchgear with single and multiple busbars are supported. The number of switchgear devices to be controlled is limited only by the number of binary inputs and outputs. Interlocking checks ensure high security against maloperation and a multitude of switchgear types and operating modes are available.

2.24.1 Control Device

Switchgear can also be controlled via the device's operator panel, DIGSI or a connection to the substation control equipment.

Applications

- Switchgear with single and double busbars

Prerequisites

The number of switchgear devices to be controlled is limited by the

- existing binary inputs
- existing binary outputs.

2.24.1.1 Description

Operation Using the Device's Operator Panel

For controlling the device, there are two independent colored keys located below the graphic display. If you are somewhere in the menu system outside the control submenu, you can return to the control mode via one of these keys.

Then, select the switchgear to be operated with the help of the navigation keys. The switching direction is determined by operating the I or O pushbutton. The selected switching direction is displayed flashing in the bottom line of the following security prompt.

Password and security prompts prevent unintended switching operations. With ENTER the entries are confirmed.

Cancellation is possible at any time before the control command is issued or during switch selection via the Esc key.

Command end, feedback or any violation of the interlocking conditions are indicated.

For further information on the device operation, please refer to Chapter 2.25.

Operation using DIGSI

Switchgear can be controlled via the operator control interface with a PC using the DIGSI software. The procedure to do so is described in the SIPROTEC 4 System Description (Control of Switchgear).

Operation Using the System Interface

Switchgear can be controlled via the serial system interface and a connection to the substation control equipment. For that it is necessary that the required periphery is physically existing in the device as well as in the substation. Furthermore, certain settings for the serial interface need to be made in the device (see SIPROTEC 4 System Description).

2.24.1.2 Information List

No.	Information	Type of Information	Comments
-	52Breaker	CF_D12	52 Breaker
-	52Breaker	DP	52 Breaker
-	Disc.Swit.	CF_D2	Disconnect Switch
-	Disc.Swit.	DP	Disconnect Switch
-	GndSwit.	CF_D2	Ground Switch
-	GndSwit.	DP	Ground Switch
31000	Q0 OpCnt=	VI	Q0 operationcounter=
31001	Q1 OpCnt=	VI	Q1 operationcounter=
31008	Q8 OpCnt=	VI	Q8 operationcounter=

2.24.2 Command Types

In conjunction with the power system control several command types can be distinguished for the device:

2.24.2.1 Description

Commands to the Process

These are all commands that are directly output to the switchgear to change their process state:

- Switching commands for controlling the circuit breakers (not synchronized), disconnectors and ground electrodes
- Step commands, e.g. raising and lowering transformer LTCs
- Set-point commands with configurable time settings, e.g. to control Petersen coils

Internal / Pseudo Commands

They do not directly operate binary outputs. They serve to initiate internal functions, simulate changes of state, or to acknowledge changes of state.

- Manual overriding commands to manually update information on process-dependent objects such as annunciations and switching states, e.g. if the communication with the process is interrupted. Manually overridden objects are flagged as such in the information status and can be displayed accordingly.
- Tagging commands (for "setting") of the information value of internal objects, for example switching authority (remote/local), settings group switching, data transmission block and deleting/presetting metered values.
- Acknowledgment and resetting commands for setting and resetting internal buffers or data states.
- Information status command to set/reset the additional information "information status" of a process object, such as:
 - Input blocking
 - Output blocking

2.24.3 Command Sequence

Safety mechanisms in the command sequence ensure that a command can only be released after a thorough check of preset criteria has been successfully concluded. Standard Interlocking checks are provided for each individual control command. Additionally, user-defined interlocking conditions can be programmed separately for each command. The actual execution of the command is also monitored afterwards. The overall command task procedure is described in brief in the following list:

2.24.3.1 Description

Check Sequence

Please observe the following:

- Command Entry, e.g. using the keypad on the local user interface of the device
 - Check Password → Access Rights
 - Check Switching Mode (interlocking activated/deactivated) → Selection of Deactivated interlocking Recognition.
- User configurable interlocking checks
 - Switching Authority
 - Device Position Check (set vs. actual comparison)
 - Interlocking, Zone Controlled (logic using CFC)
 - System Interlocking (centrally, using SCADA system or substation controller)
 - Double Operation (interlocking against parallel switching operation)
 - Protection Blocking (blocking of switching operations by protective functions).
- Fixed Command Checks
 - Internal Process Time (software watch dog which checks the time for processing the control action between initiation of the control and final close of the relay contact)
 - Setting Modification in Process (if setting modification is in process, commands are denied or delayed)
 - Operating equipment enabled as output (if an operating equipment component was configured, but not configured to a binary input, the command is denied)
 - Output Block (if an output block has been programmed for the circuit breaker, and is active at the moment the command is processed, then the command is denied)
 - Board Hardware Error
 - Command in Progress (only one command can be processed at a time for one operating equipment, object-related Double Operation Block)
 - 1-of-n-check (for schemes with multiple assignments, such as relays contact sharing a common terminal a check is made if a command is already active for this set of output relays).

Monitoring the Command Execution

The following is monitored:

- Interruption of a command because of a Cancel Command
- Runtime Monitor (feedback message monitoring time)

2.24.4 Interlocking

System interlocking is executed by the user-defined logic (CFC).

2.24.4.1 Description

Interlocking checks in a SICAM / SIPROTEC 4 system are normally divided in the following groups:

- System interlocking relies on the system data base in the substation or central control system.
- Bay interlocking relies on the object data base (feedbacks) of the bay unit.
- Cross-bay interlocking via GOOSE messages directly between bay units and protection relays (inter-relay communication with GOOSE is accomplished via the EN100 module).

The extent of the interlocking checks is determined by the configuration of the relay. To obtain more information about GOOSE, please refer to the SIPROTEC 4 System Description /1/.

Switching objects that require system interlocking in a central control system are assigned to a specific parameter inside the bay unit (via configuration matrix).

For all commands, operation with interlocking (normal mode) or without interlocking (Interlocking OFF) can be selected:

- For local commands by reprogramming the settings with password prompt
- For automatic commands, via command processing, by CFC and deactivated interlocking recognition,
- For local / remote commands, using an additional interlocking disable command, via Profibus.

Interlocked / Non-Interlocked Switching

The configurable command checks in the SIPROTEC 4 devices are also called "standard interlocking". These checks can be activated via DIGSI (interlocked switching/tagging) or deactivated (non-interlocked).

Deactivated interlock switching means the configured interlocking conditions are not checked in the relay.

Interlocked switching means that all configured interlocking conditions are checked within the command processing. If a condition is not fulfilled, the command will be rejected by a message with a minus added to it (e.g. „CO-“), immediately followed by a message.

The following table shows the possible types of commands in a switching device and their corresponding annunciations. For the device the messages designated with *) are displayed in the event logs, for DIGSI they appear in spontaneous messages.

Type of Command	Command	Cause	Message
Control issued	Switching	CO	CO+/-
Manual tagging (positive / negative)	Manual tagging	MT	MT+/-
Information state command, input blocking	Input blocking	ST	ST+/- *)
Information state command, output blocking	Output blocking	ST	ST+/- *)
Cancel command	Cancel	CA	CA+/-

The "plus" appearing in the message is a confirmation of the command execution. The command execution was as expected, in other words positive. The minus sign means a negative confirmation, the command was rejected. Possible command feedbacks and their causes are dealt with in the SIPROTEC 4 System Description. The following figure shows operational indications relating to command execution and operation response information for successful switching of the circuit breaker.

The check of interlocking can be programmed separately for all switching devices and tags that were set with a tagging command. Other internal commands such as manual entry or abort are not checked, i.e. carried out independent of the interlocking.

EVENT LOG	
19.06.01	11:52:05,625
Q0	CO+ Close
19.06.01	11:52:06,134
Q0	FB+ Close

Figure 2-137 Example of an operational annunciation for switching circuit breaker 52 (Q0)

Standard Interlocking (default)

The standard interlockings contain the following fixed programmed tests for each switching device, which can be individually enabled or disabled using parameters:

- **Device Status Check (set = actual):** The switching command is rejected, and an error indication is displayed if the circuit breaker is already in the set position. (If this check is enabled, then it works whether interlocking, e.g. zone controlled, is activated or deactivated.) This condition is checked in both interlocked and non-interlocked status modes.
- **System Interlocking:** To check the power system interlocking, a local command is transmitted to the central unit with Switching Authority = LOCAL. A switching device that is subject to system interlocking cannot be switched by DIGSI.
- **Zone control:** User-specific logic links created with CFC are interrogated and considered during interlocked switching.
- **Blocking by Protection:** Switch-ON commands are rejected with interlocked switches, as soon as one of the protection functions of the unit has opened a fault case. However, trip commands can always be executed. Please be aware, activation of thermal overload protection elements or sensitive ground fault detection can create and maintain a fault condition status, and can therefore block CLOSE commands.
- **Double Operation Block:** Parallel switching operations are interlocked against one another; while one command is processed, a second cannot be carried out.
- **Switching Authority LOCAL:** A switch command from local control (command with source LOCAL) is only allowed if local control is enabled at the device (by configuration).
- **Switching Authority DIGSI:** Switching commands that are issued locally or remotely via DIGSI (command with source DIGSI) are only allowed if remote control is enabled at the device (by configuration). If a DIGSI computer logs on to the device, it leaves a Virtual Device Number (VD). Only commands with this VD (when Switching Authority = REMOTE) will be accepted by the device. Remote switching commands will be rejected.
- **Switching authority REMOTE:** A remote switch command (command with source REMOTE) is only allowed if remote control is enabled at the device (by configuration).

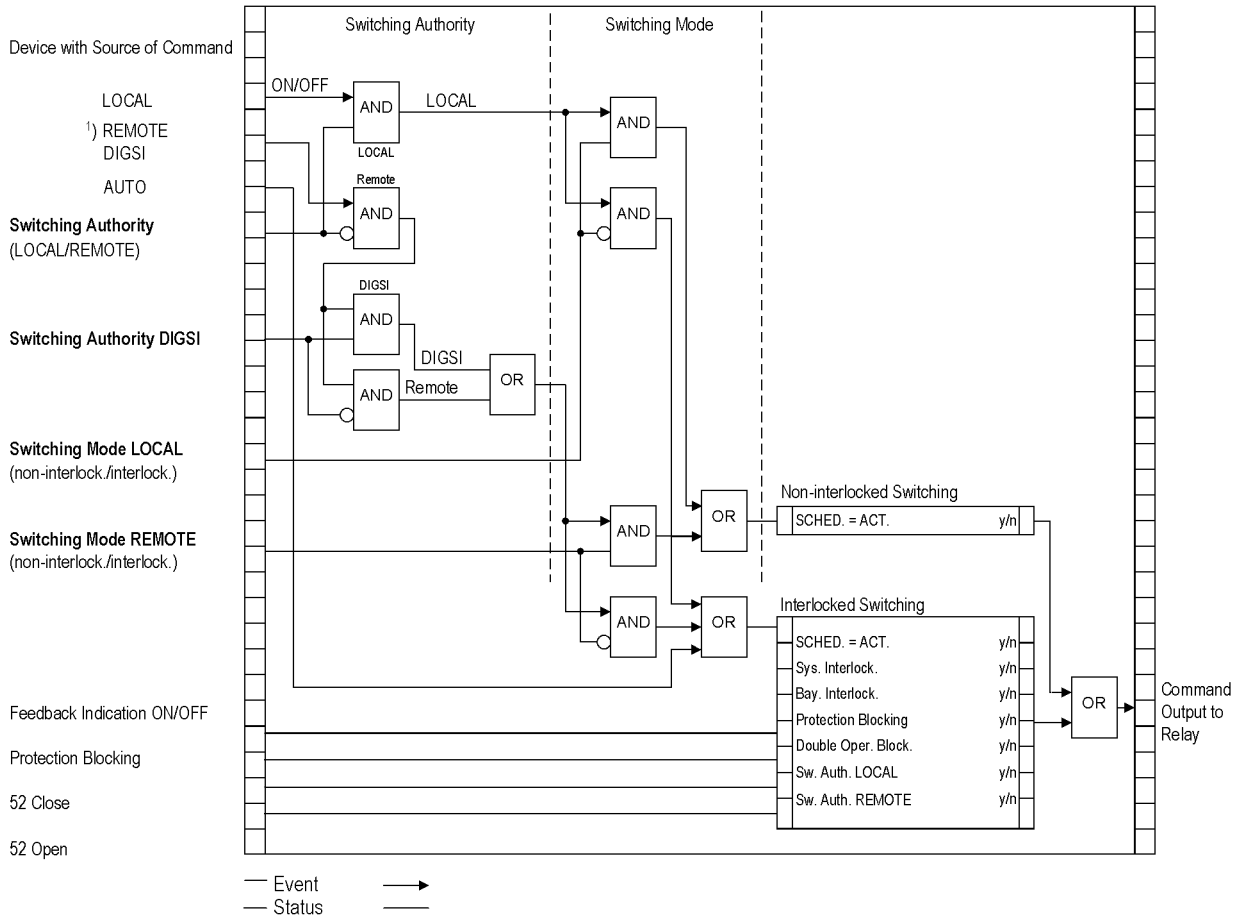

*) Source REMOTE also includes SAS.
 (LOCAL Command using substation controller
 REMOTE Command using remote source such as SCADA through controller to device.)

Figure 2-138 Standard interlockings

The following figure shows the configuration of the interlocking conditions using DIGSI.

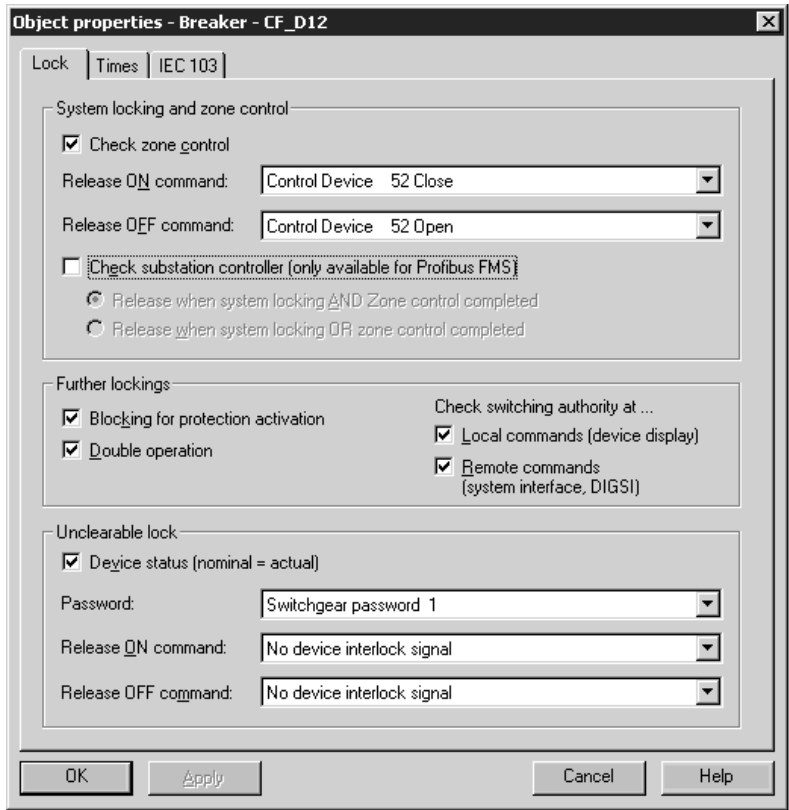

Figure 2-139 DIGSI dialog box for setting the interlocking conditions

The configured interlocking causes are displayed on the device display. They are marked by letters explained in the following table.

Table 2-26 Command types and corresponding messages

Interlocking Commands	Abbrev.	Display
Switching Authority	L	L
System interlocking	S	A
Zone controlled	Z	Z
SET = ACTUAL (switch direction check)	P	P
Protection blocking	B	B

Control Logic using CFC

For bay interlocking, a release logic can be created using CFC. Via specific release conditions the information "released" or "bay interlocked" are available (e.g. object "52 Close" and "52 Open" with the data values: ON/OFF).

Switching Authority

The interlocking condition "Switching authority" serves for determining the switching authority. It enables the user to select the authorized command source. The following switching authority ranges are defined in the following priority sequence:

- LOCAL
- DIGSI
- REMOTE

The "Switching authority" object serves for interlocking or enabling LOCAL control but not REMOTE or DIGSI commands. With a 7SJ80, the switching authority can be changed between "REMOTE" and "LOCAL" on the operator panel after having entered the password or by means of CFC also via binary inputs and a function key.

The "Switching authority DIGSI" object is used for interlocking or enabling operation via DIGSI. This allows for local as well as remote DIGSI connections. When a (local or remote) DIGSI PC logs on to the device, it enters its virtual device number (VD). Only commands with this VD (when switching authority = OFF or REMOTE) are accepted by the device. When the DIGSI PC logs off again, the VD is canceled.

Commands are checked for their source CS and the device settings and compared to the current status set in the objects "Switching authority" and "Switching authority DIGSI".

Configuration

Switching authority available	y/n (create appropriate object)
Switching authority DIGSI available:	y/n (create appropriate object)
Specific device (e.g. switchgear)	Switching authority LOCAL (check for LOCAL status): y/n
Specific device (e.g. switchgear)	Switching authority REMOTE (check for LOCAL, REMOTE or DIGSI commands): y/n

Table 2-27 Interlocking logic

Current switching authority status	Switching authority DIGSI	Command issued with CS ³⁾ =LOCAL	Command issued with CS=LOCAL or REMOTE	Command issued with CS=DIGSI
LOCAL (ON)	Not registered	Enabled	Interlocked ²⁾ - "Switching authority LOCAL"	Interlocked - "DIGSI not registered"
LOCAL (ON)	Registered	Enabled	Interlocked ²⁾ - "Switching authority LOCAL"	Interlocked ²⁾ - "Switching authority LOCAL"
REMOTE (OFF)	Not registered	Interlocked ¹⁾ - "Switching authority REMOTE"	Enabled	Interlocked - "DIGSI not registered"
REMOTE (OFF)	Registered	Interlocked ¹⁾ - "Switching authority DIGSI"	Interlocked ²⁾ - "Switching authority DIGSI"	Enabled

1) also "Enabled" for: "Switching Authority LOCAL (check for LOCAL status): n"
 2) also "Enabled" for: "Switching authority REMOTE (check for LOCAL, REMOTE or DIGSI commands): n"
 3) CS = command source

CS = Auto:

Commands that are initiated internally (command processing in the CFC) are not subject to the switching authority and are therefore always "enabled".

Switching Mode

The switching mode serves for activating or deactivating the configured interlocking conditions at the time of the switching operation.

The following switching modes (local) are defined:

- For local commands (CS = LOCAL)
 - locked (normal) or
 - unlocked (unlatched) switching.

With a 7SJ80, the switching mode can be changed between "locked" and "unlocked" on the operator panel after having entered the password or by means of CFC also via binary inputs and a function key.

The following switching modes (remote) are defined:

- For remote or DIGSI commands (CS = LOCAL, REMOTE or DIGSI)
 - locked or
 - unlocked (unlatched) switching. Here, deactivation of the interlocking is accomplished via a separate unlocking command.
 - For commands from CFC (CS = Auto), please observe the notes in the CFC manual (component: BOOL to command).

Zone Controlled / Field Interlocking

Zone controlled / field interlocking (e.g. via CFC) includes the verification that predetermined switchgear position conditions are satisfied to prevent switching errors (e.g. disconnecter vs. ground switch, ground switch only if no voltage applied) as well as verification of the state of other mechanical interlocking in the switchgear bay (e.g. High Voltage compartment doors).

Interlocking conditions can be programmed separately, for each switching device, for device control CLOSE and/or OPEN.

The enable information with the data "switching device is interlocked (OFF/NV/FLT) or enabled (ON)" can be set up,

- directly, using a single-point or double-point indication or internal message (tagging), or
- by means of a control logic via CFC.

When a switching command is initiated, the actual status is scanned cyclically. The assignment is done via "Release object CLOSE/OPEN".

System Interlocking

Substation Controller (System interlocking) involves switchgear conditions of other bays evaluated by a central control system.

Double Activation Blockage

Parallel switching operations are interlocked. As soon as the command has arrived all command objects subject to the interlocking are checked to know whether a command is being processed. While the command is being executed, interlocking is enabled for other commands.

Blocking by Protection

The pickup of protective elements blocks switching operations. Protective elements are configured, separately for each switching component, to block specific switching commands sent in CLOSE and TRIP direction.

When enabled, "Block CLOSE commands" blocks CLOSE commands, whereas "Block TRIP commands" blocks TRIP signals. Switching operations in progress will immediately be aborted by the pickup of a protective element.

Device Status Check (set = actual)

For switching commands, a check takes place whether the selected switching device is already in the set/desired position (set/actual comparison). This means, if a circuit breaker is already in the CLOSED position and an attempt is made to issue a closing command, the command will be refused, with the operating message "set condition equals actual condition". If the circuit breaker / switchgear device is in the intermediate position, then this check is not performed.

Bypassing Interlocking

Bypassing configured interlockings at the time of the switching action happens device-internal via interlocking recognition in the command job or globally via so-called switching modes.

- SC=LOCAL
 - The user can switch between the modes "interlocked" or "non-interlocked" (bypassed) in the operator panel after entering the password or using CFC via binary input and function key.
- REMOTE and DIGSI
 - Commands issued by SICAM or DIGSI are unlocked via a global switching mode REMOTE. A separate request must be sent for the unlocking. The unlocking applies only for one switching operation and for commands caused by the same source.
 - Job order: command to object "Switching mode REMOTE", ON
 - Job order: switching command to "switching device"
- Command via CFC (automatic command, SC=Auto SICAM):
 - Behavior configured in the CFC block ("BOOL to command").

2.24.5 Command Logging

During the processing of the commands, independent of the further message routing and processing, command and process feedback information are sent to the message processing center. These messages contain information on the cause. With the corresponding allocation (configuration) these messages are entered in the event list, thus serving as a report.

Prerequisites

A listing of possible operating messages and their meaning as well as the command types needed for tripping and closing of the switchgear or for raising and lowering of transformer taps are described in the SIPROTEC 4 System Description.

2.24.5.1 Description

Acknowledgment of Commands to the Device Front

All messages with the source of command LOCAL are transformed into a corresponding response and shown in the display of the device.

Acknowledgment of commands to Local / Remote / DigsI

The acknowledgment of messages with source of command Local/ Remote/DIGSI are sent back to the initiating point independent of the routing (configuration on the serial digital interface).

The acknowledgment of commands is therefore not executed by a response indication as it is done with the local command but by ordinary command and feedback information recording.

Monitoring of Feedback Information

The processing of commands monitors the command execution and timing of feedback information for all commands. At the same time the command is sent, the monitoring time is started (monitoring of the command execution). This time controls whether the device achieves the required final result within the monitoring time. The monitoring time is stopped as soon as the feedback information arrives. If no feedback information arrives, a response "Timeout command monitoring time" appears and the process is terminated.

Commands and information feedback are also recorded in the event list. Normally the execution of a command is terminated as soon as the feedback information (**FB+**) of the relevant switchgear arrives or, in case of commands without process feedback information, the command output resets and a message is output.

The "plus" sign appearing in a feedback information confirms that the command was successful. The command was as expected, in other words positive. The "minus" is a negative confirmation and means that the command was not executed as expected.

Command Output and Switching Relays



The command types needed for tripping and closing of the switchgear or for raising and lowering of transformer taps are described in the configuration section of the SIPROTEC 4 System Description /1/ .

2.25 Notes on Device Operation

The operation of the 7SJ80 slightly differs from the other SIPROTEC 4 devices. These differences are described in the following. General information regarding the operation and configuration of SIPROTEC 4 devices is set out in the SIPROTEC 4 System Description.

2.25.1 Different operation

Pushbuttons of the Control Panels

Pushbutton	Function/meaning
Enter	Confirming entries and navigating forward in the menus
Esc	Navigating to the main menu (where necessary, press repeatedly), navigating backwards in the menus, discarding entries
	Testing the LEDs Resetting the LED memory and binary outputs
Fn	Function key Fn for displaying the assignment of the function keys. If several function keys have been assigned, a second page is displayed for the assignment when leaving through, if required. Combined pushbutton with numeric keys for a faster navigation (e.g. Fn + 1 operational messages) Navigation to the main menu with Fn in combination with the numeric key 0.
	For setting the contrast, keep the pushbutton pressed for about 5 seconds. Set the contrast in the menu with the scrolling keys (downward: less contrast, upward: more contrast).

Entry of Negative Signs

Only a few parameters can reach a negative value, i.e. a negative sign can only be entered for these.

If a negative sign is permissible, the prompt `-/+ --> v/^` appears in the bottom line when changing the parameter. The sign can be determined via the scrolling keys: downward = negative sign, upward = positive sign.

Display

The SIPROTEC 4 System Description applies to devices with a 4-line ASCII display. Apart from that there are devices with a graphical display and a size of 30 lines. The 7SJ80 uses the outputs of the graphical display, but with 6 lines. Therefore, the representation might differ from the representations in the System Description.

The basic differences of the device with regard to the representation are the following:

The current selection is indicated by inverse representation (not by the prefix `>`)

MAIN MENU	04/05

Annunciation	-> 1
Measurement	-> 2
Control	-> 3
Parameter	-> 4

Figure 2-140 Inverse representation of the current selection

In part, the sixth line is used for representing e.g. the active parameter group.

PARAMETER	01/08

Functional Scope ->	01
Allocation ->	02

active Setting Group	A

Figure 2-141 Representation of the active parameter group (line 6)

■

Mounting and Commissioning

3

This chapter is intended for experienced commissioning staff. He must be familiar with the commissioning of protection and control systems, the management of power systems and the safety rules and regulations. Hardware adjustments to the power system data might be necessary. The primary tests require the protected object (line, transformer, etc.) to carry load.

3.1	Mounting and Connections	356
3.2	Checking Connections	373
3.3	Commissioning	378
3.4	Final Preparation of the Device	399

3.1 Mounting and Connections

General



WARNING!

Warning of improper transport, storage, installation or assembly of the device.

Failure to observe these precautions can result in death, personal injury, or serious material damage.

Trouble-free and safe use of this device depends on proper transport, storage, installation, and assembly of the device according to the warnings in this device manual.

Of particular importance are the general installation and safety regulations for work in a high-voltage environment (for example, ANSI, IEC, EN, DIN, or other national and international regulations). These regulations must be observed.

3.1.1 Configuration Information

Prerequisites

For installation and connections the following conditions must be met:

The rated device data have been checked as recommended in the SIPROTEC 4 System Description. It has been verified that these data comply with the power system data.

General Diagrams

Block diagrams for the terminal assignment of the 7SJ80 are shown in Appendix A.2. Connection examples for the current and voltage transformer circuits are provided in Appendix A.3.

Voltage Connection Examples

Connection examples for voltage transformers are provided in Appendix A.3. It must be checked that the configuration of the **Power System Data 1** (Section 2.1.3.2) corresponds with the connections.

The normal connection is set at address 213 **VT Connect. 3ph = Van, Vbn, Vcn**.

When connecting an open delta winding of the voltage transformer set, address 213 **VT Connect. 3ph** must be set to **Vab, Vbc, VGnd**.

For the synchrocheck function, address 213 must be set to **Vab, Vbc, VSyn** or **Vph-g, VSyn**.

Another example shows the connection mode 213 = **Vab, Vbc, Vx**. The voltage connected to the third transformer Vx is only used by the flexible protection functions.

Moreover, there are examples for the connection modes **Vab, Vbc** and **Vph-g, VSyn**.

Binary Inputs and Outputs

The configuration options of the binary in- and outputs, i.e. the procedure for the individual adaptation to the plant conditions, are described in the SIPROTEC 4 System Description. The connections to the plant are dependent on this configuration. The presettings of the device are listed in Appendix A.5. Please also check that the labeling strips on the front panel correspond to the configured message functions.

Setting Group Change Function

If binary inputs are used to switch setting groups, please observe the following:

- Two binary inputs must be dedicated to the purpose of changing setting groups when four groups are to be switched. One binary input must be set for „>Set Group Bit0“, the other input for „>Set Group Bit1“. If either of these input functions is not assigned, then it is considered as not controlled.
- For the control of 2 setting groups one binary input is sufficient, namely „>Set Group Bit0“, since the non-assigned binary input „>Set Group Bit1“ is then regarded as not connected.
- The control signals must be permanently active so that the selected setting group is and remains active.

The following table shows the allocation of the binary inputs to the setting groups A to D and a simplified connection diagram for the two binary inputs is illustrated in the following figure. The figure illustrates an example in which both Set Group Bits 0 and 1 are configured to be controlled (actuated) when the associated binary input is energized (high).

Where:

- no = not energized or not connected
yes = energized

Table 3-1 Changing setting groups using binary inputs

Binary Input		Active Group
>Set Group Bit 0	>Set Group Bit 1	
No	No	Group A
Yes	No	Group B
No	Yes	Group C
Yes	Yes	Group D

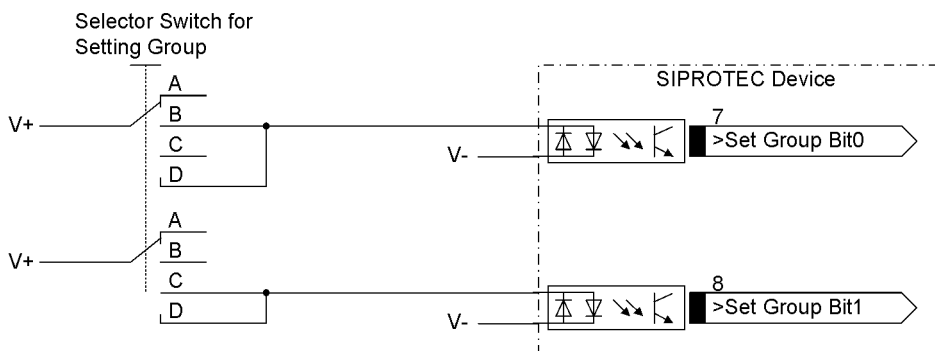

Figure 3-1 Connection diagram (example) for setting group switching using binary inputs

Trip Circuit Supervision 74TC

Please note that two binary inputs or one binary input and one bypass resistor R must be connected in series. The pick-up threshold of the binary inputs must therefore stay substantially below half the rated control DC voltage.

If one binary input is used, a bypass resistor R must be used (see following figure). The resistor R is inserted into the circuit of the 52b circuit breaker auxiliary contact to facilitate the detection of a malfunction also when the 52a circuit breaker auxiliary contact is open and the trip contact has dropped out. The value of this resistor must be such that in the circuit breaker open condition (therefore 52a is open and 52b is closed), the circuit breaker trip coil (52TC) is no longer energized and binary input (BI1) is still energized if the command relay contact is open.

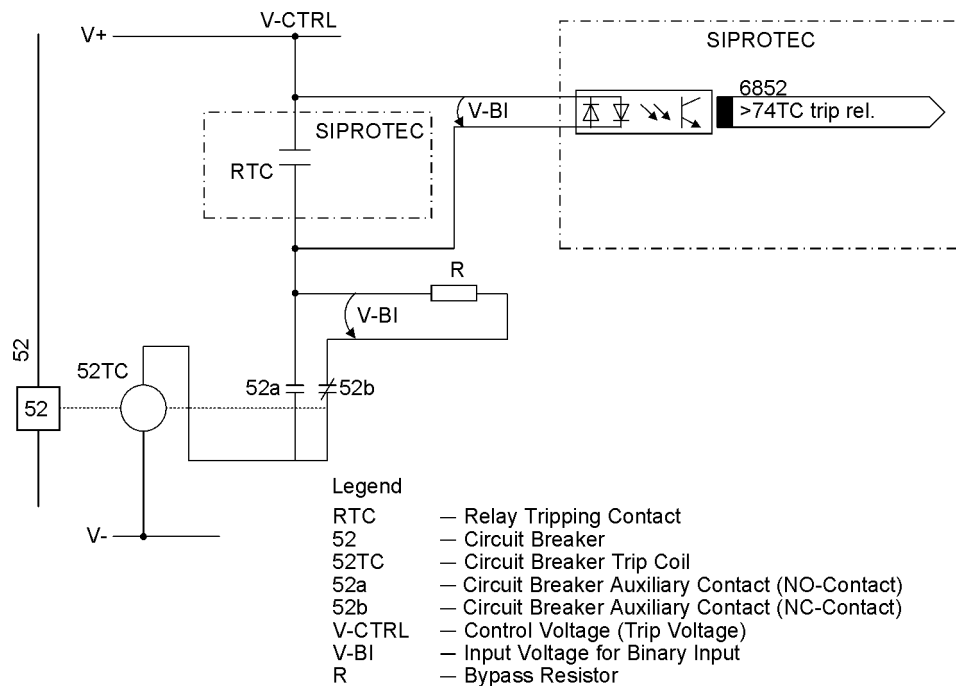

Figure 3-2 Trip circuit supervision with one binary input

This results in an upper limit for the resistance dimension, R_{max} , and a lower limit R_{min} , from which the optimal value of the arithmetic mean R should be selected:

$$R = \frac{R_{max} + R_{min}}{2}$$

In order that the minimum voltage for controlling the binary input is ensured, R_{max} is derived as:

$$R_{max} = \left(\frac{V_{CTR} - V_{BI \min}}{I_{BI \text{ (High)}}} \right) - R_{CBTC}$$

So the circuit breaker trip coil does not remain energized in the above case, R_{min} is derived as:

$$R_{min} = R_{CBTC} \cdot \left(\frac{V_{CTR} - V_{CBTC \text{ (LOW)}}}{V_{CBTC \text{ (LOW)}}} \right)$$

$I_{BI(HIGH)}$	Constant current with activated BI (= 0.25 mA)
$V_{BI\ min}$	Minimum control voltage for BI (= 19 V at delivery setting for nominal voltages of 24 V/ 48 V; 88 V at delivery setting for nominal voltages of 60 V/ 110 V/ 125 V/ 220 V/ 250 V)
V_{CTR}	Control voltage for trip circuit
R_{CBTC}	Ohmic resistance of the circuit breaker coil
$V_{CBTC(LOW)}$	Maximum voltage on the circuit breaker coil that does not lead to tripping

If the calculation has the result $R_{max} < R_{min}$, the calculation has to be repeated with the next smaller threshold $V_{BI\ min}$. This threshold is determined via the parameters 220 **Threshold BI 1** to 226 **Threshold BI 7**. The settings **Thresh. BI 176V**, **Thresh. BI 88V**, **Thresh. BI 19V** are possible.

For the power consumption of the resistance:

$$P_R = I^2 \cdot R = \left(\frac{V_{CTR}}{R + R_{CBTC}} \right)^2 \cdot R$$

Example

$I_{BI(HIGH)}$	0.25 mA (SIPROTEC 4 7SJ80)
$V_{BI\ min}$	19 V at delivery setting for nominal voltages of 24 V/ 48 V; 88 V at delivery setting for nominal voltages of 60 V/ 110 V/ 125 V/ 220 V/ 250 V)
V_{CTR}	110 V (from the system / trip circuit)
R_{CBTC}	500 Ω (from the system / trip circuit)
$V_{CBTC(LOW)}$	2 V (from the system / trip circuit)

$$R_{max} = \left(\frac{110\ V - 19\ V}{0.25\ mA} \right) - 500\ \Omega = 363.5\ k\Omega$$

$$R_{min} = \left(\frac{110\ V - 2\ V}{2\ V} \right) \cdot 500\ \Omega = 27\ k\Omega$$

$$R = \frac{R_{max} + R_{min}}{2} = 195.25\ k\Omega$$

The closest standard value 200 k Ω is selected; the following applies for the power:

$$P_R = \left(\frac{110\ V}{200\ k\Omega + 0.5\ k\Omega} \right)^2 \cdot 200\ k\Omega \geq 60\ mW$$

3.1.2 Hardware Modifications

3.1.2.1 Disassembly

Work on the Printed Circuit Boards

**Note**

Before carrying out the following steps, make sure that the device is not operative.

**Note**

Apart from the communication modules and the fuse, there are no further components that can be configured or operated by the user inside the device. Any service activities exceeding the installation or exchange of communication modules must only be carried out by Siemens personnel.

For preparing the workplace, a pad suitable for electrostatic sensitive devices (ESD) is required.

Additionally, the following tools are required:

- a screwdriver with a 5 mm to 6 mm (0.20 – 0.24 in) wide blade,
- a Philips screwdriver size 1,
- a 5 mm (0.20 in) socket or nut driver

In order to disassemble the device, first remove it from the substation installation. To do so, perform the steps stated in Sections Panel Flush Mounting, Panel Surface Mounting or Cubicle Mounting in reverse order.

**Note**

The following must absolutely be observed:

Disconnect the communication connections at the device bottom (ports A and B). If this is not observed, the communication lines and/or the device might be destroyed.

**Note**

To use the device, all terminal blocks must be plugged in.

**Caution!**

Mind electrostatic discharges

Failure to observe these precautions can result in personal injury or material damage.

Any electrostatic discharges while working at the electronics block are to be avoided. We recommend ESD protective equipment (grounding strap, conductive grounded shoes, ESD-suitable clothing, etc.). Alternatively, an electrostatic charge is to be discharged by touching grounded metal parts.



Note

In order to minimize the expenditure for reconnecting the device, remove the completely wired terminal blocks from the device. To do so, open the elastic holders of the terminal blocks in pairs with a flat screwdriver and remove the terminal blocks to the back. When reinstalling the device, insert the terminal blocks back into the device like assembled terminals (Sections Panel Flush Mounting, Panel Surface Mounting or Cubicle Mounting).

In order to install or exchange communication modules or to replace the fuse, proceed as follows:

Remove the two covers at the top and bottom. Thus, 1 housing screw each at the top and bottom becomes accessible. First, only unscrew the bottom housing screw so far that its tip no longer looks out of the thread of the mounting bracket (the housing screws are captive, they remain in the front cover even when unscrewed).

Unscrew all screws that fasten any existing communication modules in the module cover on the bottom side of the device. Also unscrew the 4 countersunk screws that fasten the module cover on the bottom side of the device. Carefully pull the entire module cover out of the device.

Only now completely unscrew the two housing screws at the top and bottom in the cover and carefully remove the complete electronics block from the housing (Figure 3-3).



Note

If you have not removed the terminal blocks from the rear panel, much more force is required for removing and reinstalling the electronics block, which might lead to the damaging of the device. Therefore, we absolutely recommend to remove the terminal blocks before removing the electronics block.

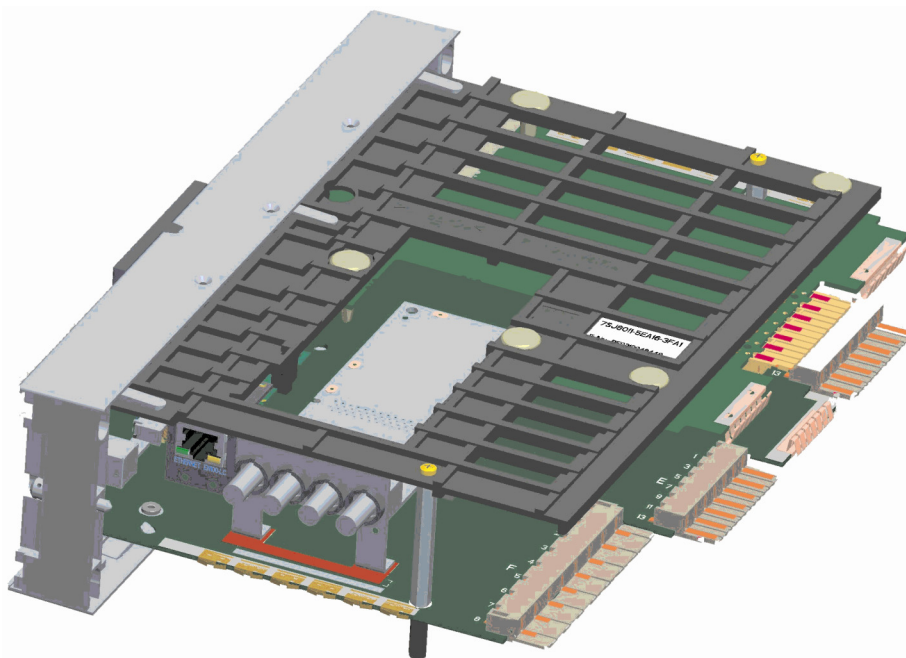

Figure 3-3 Electronics block without housing

Replacing the Fuse

The fuse holder is located at the edge of the basic I/O board close to the power supply connection.

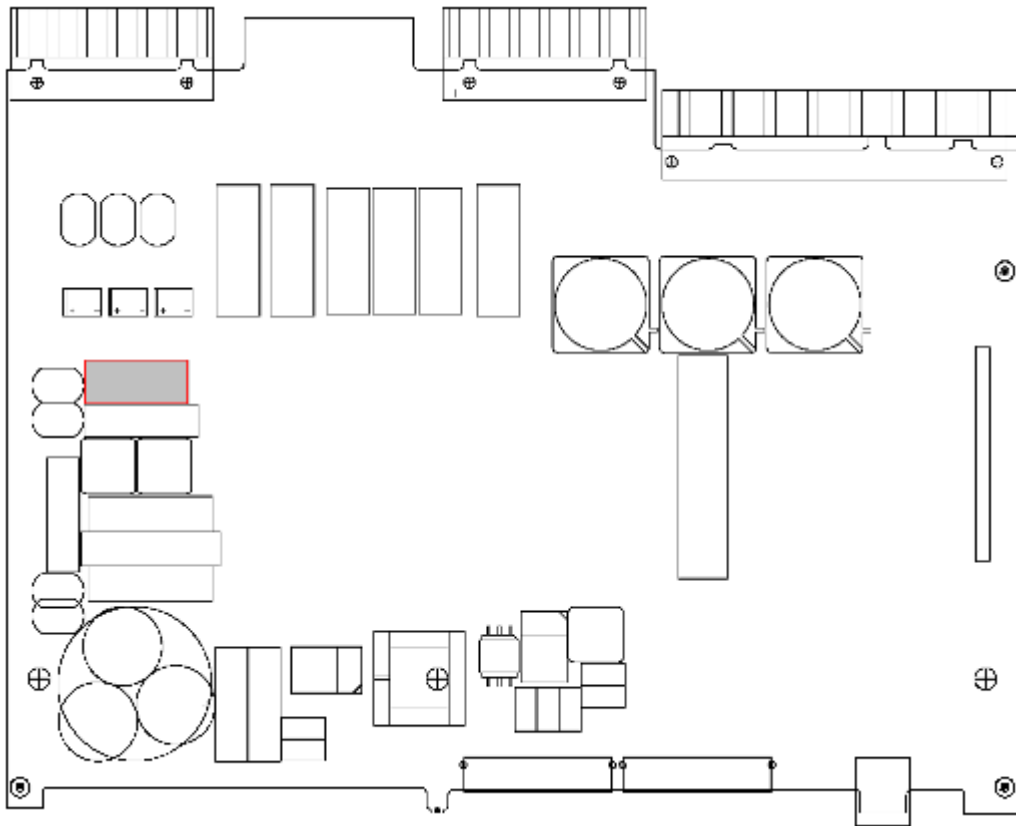

Figure 3-4 Placing the fuse

Remove the defective fuse. Insert the new fuse with the following technical data into the fuse holder:

5 mm x 20 mm (0.20 * 0.79 in) safety fuse

T characteristic

2.0 A nominal current

250 V nominal voltage

Switching capability 1500 VA/ 300 VDC

Only UL-approved fuses may be used.

This data applies to all device types (24 V/48 V and 60 V – 250 V).

Make sure that the defective fuse has not left any obvious damage on the device. If the fuse trips again after reconnection of the device, refrain from any further repairs and send the device to Siemens for repair.

The device can now be reassembled again (see Section Reassembly).

3.1.2.2 Connections of the Current Terminals

Fixing Elements

The fixing elements for the transformer connection are part of the current terminal (housing side). They have a stress-crack- and corrosion-resistant alloy. The head shape of the terminal screw allows for using a flat screwdriver (5.0 x 1.0 mm) or a crosstip screwdriver (PZ2). We recommend PZ2.

Cable Lugs and Wire Cross-sections

There are two connection options: the connection of single wires and the connection with a ring lug. Only copper wires may be used.

We recommend ring lugs with the following dimensions:

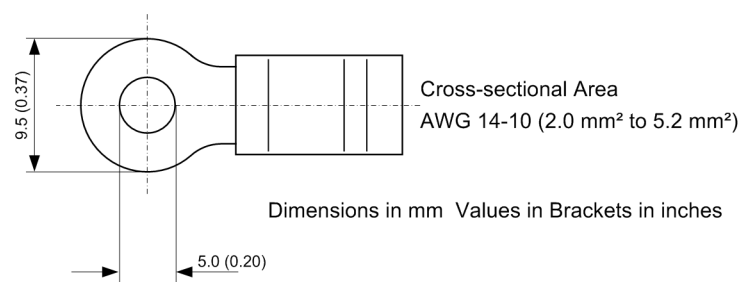

Figure 3-5 Ring lug

For complying with the required insulation clearances, insulated ring lugs have to be used. Otherwise, the crimp zone has to be insulated with corresponding means (e.g. by pulling a shrink-on sleeve over).

We recommend ring lugs of the PIDG range from Tyco Electronics.

Two ring lugs can be mounted per connection.

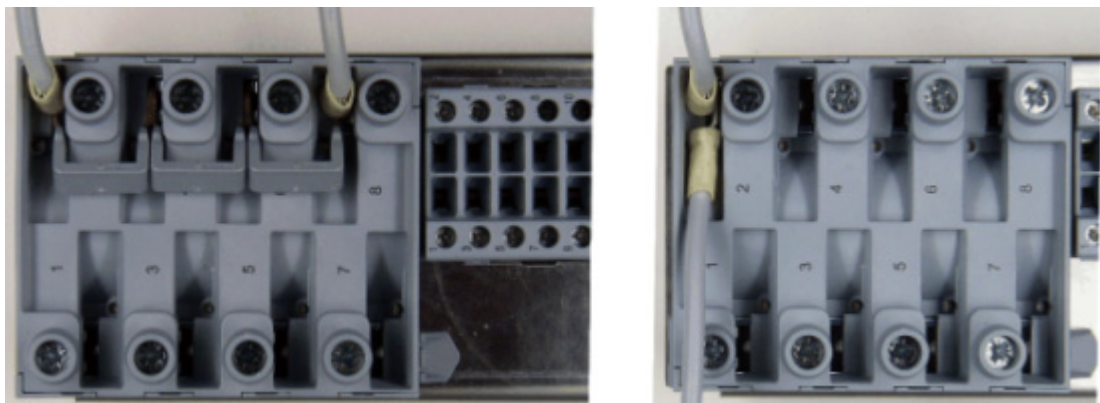

Figure 3-6 Current transformer connection

As single wires, solid conductors as well as stranded conductors with conductor sleeves can be used. Up to two single wires with identical cross-sections can be used per connection.

Alternatively jumpers (Order No. C53207-A406-D193-1) can be used with terminal points in a stacked arrangement. When using jumpers, only ring lugs are allowed.

When connecting single wires, the following cross-sections are allowed:

Cable cross-section:	AWG 14-10 (2.0 mm ² to 5.2 mm ²)
Connector sleeve with plastic collar	L = 10 mm (0.39 in) or L = 12 mm (0.47 in)
Stripping length: (when used without conductor sleeve)	15 mm (0.59 in) Use exclusively solid copper conductors.

Mechanical Requirements

The fixing elements and the connected components are designed for the following mechanical requirements:

Permissible tightening torque at the terminal screw	2.7 Nm (23.9 lb.in) With solid conductors the allowed maximum tightening torque is 2 Nm
Permissible traction per connected conductor	80 N based on IEC 60947-1 (VDE 660, Part 100)

3.1.2.3 Connections of the Voltage Terminals

Fixing Elements

The fixing elements for the voltage transformer connection are part of the voltage terminal (housing side). They have a stress-crack- and corrosion-resistant alloy. The head shape of the terminal screw allows for using a flat screwdriver (4.0 mm x 0.8 mm / 0.16 in x 0.031 in) or a crosstip screwdriver (PZ1). PZ1 is recommended.

Cable Lugs and Wire Cross-sections

The connection mode available is the connection as single cable. As single cables, solid conductors as well as stranded conductors with or without conductor sleeves can be used. We recommend using twin cable end sleeves when connecting two single cables. We recommend the twin cable end sleeves of the series PN 966 144 from Tyco Electronics.

When connecting single cables, the following cross-sections are allowed:

Cable cross-sections:	AWG 20-14 (0.5 mm ² to 2.0 mm ²)
Connector sleeve with plastic collar	L = 10 mm (0.39 in) or L = 12 mm (0.47 in)
Stripping length: (when used without conductor sleeve)	12 mm (0.47 in) Only copper cables may be used.

With terminal points lying one below the other you may connect single conductors and jumpers (Order No. C53207-A406-D194-1) together. Please make sure that neighboring jumpers are built in/connected alternately.

Mechanical Requirements

The fixing elements and the connected components are designed for the following mechanical requirements:

Permissible tightening torque at the terminal screw	1.0 Nm (8.85 lb.in)
Permissible traction per connected conductor	50 N based on IEC 60947-1 (VDE 660, Part 100)

3.1.2.4 Interface Modules

General

The 7SJ80 relay is supplied with preconfigured interfaces according to the ordering version. You do not have to make any adaptations to the hardware (e.g. plugging in jumpers) yourself, except for the installation or replacement of communication modules.

The use of the interface modules RS232, RS485 and optical can be defined via the parameter 617 ServiProt. This parameter is only visible if the 11th digit of the ordering number was selected to be 1 for RS232, 2 for RS485 or 3 for optical.

Installation or Replacement of the Ethernet Interface Module

The following requirement must be fulfilled:

There is no SIPROTEC 4 communication module mounted yet. Otherwise, this has to be removed before actually installing the Ethernet interface module (see below).

The Ethernet interface module is inserted in the respective slot, most suitably from the open bottom, i.e. above the back of the battery case. A supporting frame is placed over the modular plug. The narrow spacer lies at edge of the printed circuit board. The module is attached to the 50-pole plug connector of the CPU module slightly inclined to the basic I/O board. The supporting plate is slightly pulled outwards in this area. The module can now be inserted vertically up to the stop. Then, the supporting plate is pressed against in the area of the locking latch until the upper edge of the printed circuit board of the Ethernet interface module snaps into the locking latch.

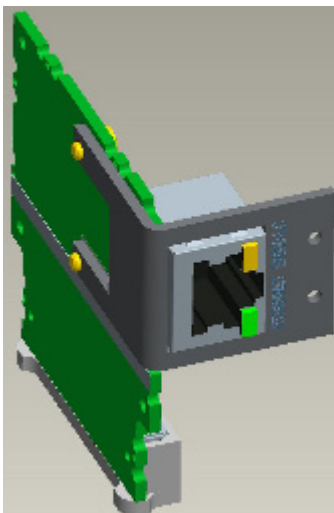

Figure 3-7 Ethernet interface with support frame

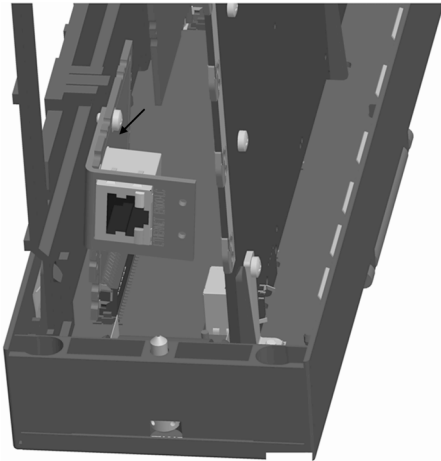

Figure 3-8 Installation of the Ethernet interface

Now, a SIPROTEC 4 communication module can be installed (see Section Installation or Replacement of a SIPROTEC 4 Communication Module). Otherwise, the device can be reassembled again (see Section Reassembly).

Installation or Replacement of a SIPROTEC 4 Communication Module

The following description assumes the normal case that a SIPROTEC 4 communication module which has not yet been existing is retrofitted.

If a SIPROTEC 4 communication module has to be removed or replaced, the steps are to be performed in reverse order.



Note

The installation can only be performed alone or after the installation of the Ethernet module.

The SIPROTEC 4 communication module is inserted via the large window in the plastic supporting plate. The direction of insertion is not arbitrary. The module is held at its mounting bracket. The opposite end of the module is inserted with the same orientation in the window opening, under the supporting plate and any existing extension I/O. The module bracket is turned towards the Ethernet module locking latch at the supporting plate. Thus, even the longest connection elements of the communication module can be moved in this space between the lower supporting plate reinforcement and the locking latch in the direction of the transformer module. The mounting bracket of the module is now drawn up to the stop in the direction of the lower supporting plate reinforcement. Thus, the 60-pin plug connector on the module and the basic I/O board are aligned on top of each other. The alignment has to be checked via the opening at the bottom of the rack. Attach the module's mounting rail from the back side of the basic I/O using 2 M 2.5 screws.

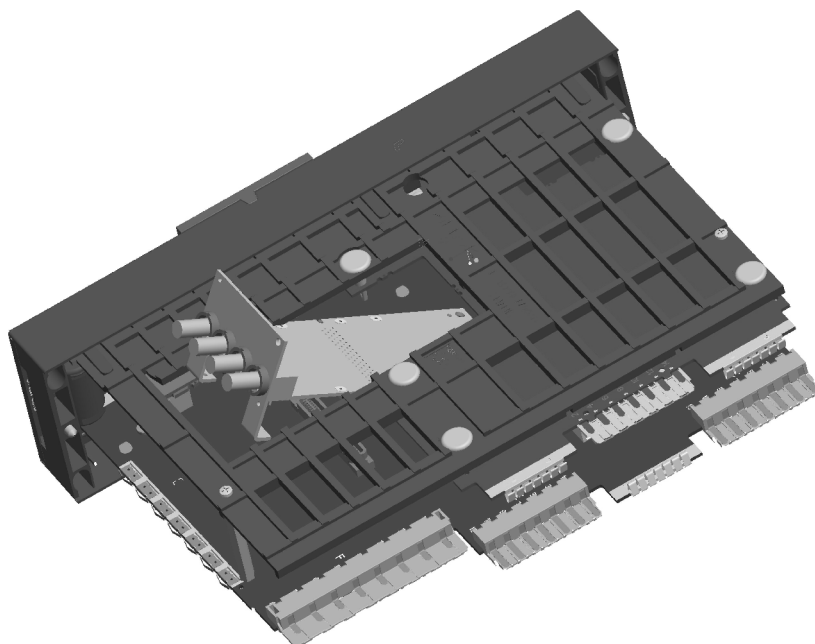

Figure 3-9 Installation of a SIPROTEC 4 communication module

The device can now be reassembled again (see Section Reassembly).

3.1.2.5 Reassembly

The reassembly of the device is performed in the following steps:

Carefully insert the complete electronics block into the housing. Please observe the following:

The connections of the communication modules point at the bottom of the housing. If there is no communication module, orient yourself to the connections for the current terminal. These connections are located on the side of the printed circuit board pointing at the device bottom.

Insert the electronics block into the housing, until the supporting part rests against the front edge of the housing. Press the left housing wall slightly out and insert the electronics block carefully further into the housing. When the front edge of the housing and the inside of the front plate touch, center the front plate by careful lateral movements. This makes sure that the front plate encloses/surrounds the housing. The electronics block can only be inserted centered up to the end stop.

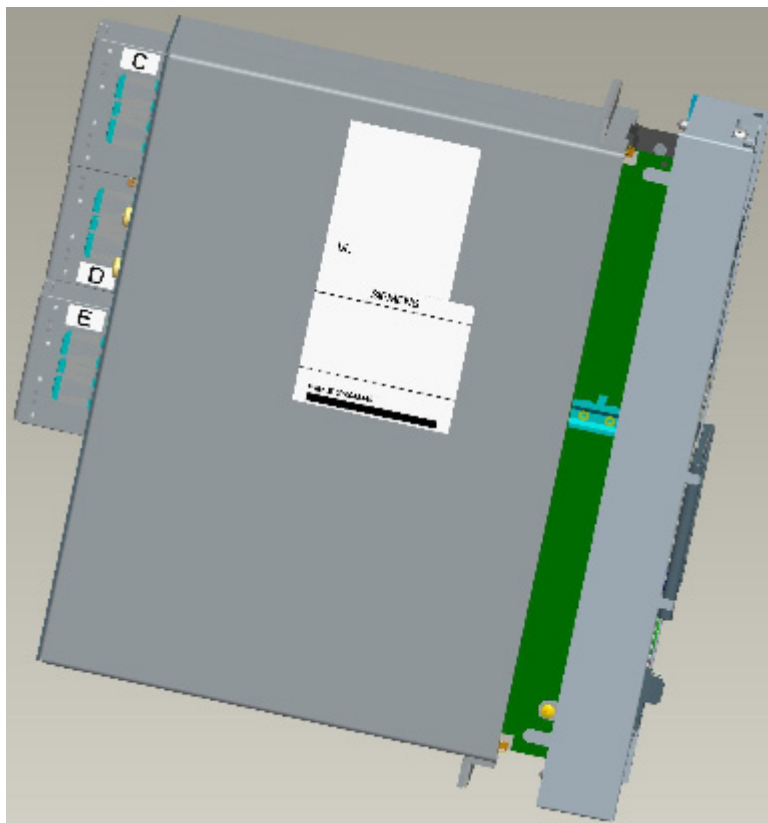

Figure 3-10 Reassembly of Device

Fix the front cover to the housing with the two medium screws at the top and bottom of the front cover. The two covers can be inserted again either now or after the reinstallation of the device. Now install the device in accordance with the Sections Panel Flush Mounting, Panel Surface Mounting or Cubicle Mounting.



Note

Insert the current and voltage terminal blocks again and lock them in place!

3.1.3 Installation

3.1.3.1 General

The 7SJ80 relay has a housing size 1/6. The housing has 2 covers and 4 fixing holes each at the top and bottom (see Figure 3-11 and Figure 3-12).

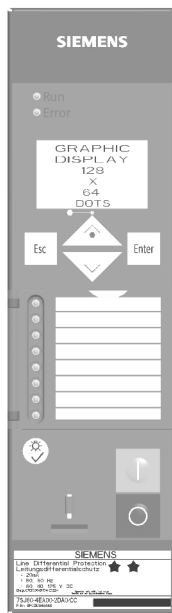

Figure 3-11 Housing with covers



Figure 3-12 Housing with fixing holes (without covers)

3.1.3.2 Panel Flush Mounting

The housing (housing size $\frac{1}{6}$) has 2 covers and 4 fixing holes.

- Remove the 2 covers at the top and bottom of the front cover. Thus, 4 elongated holes are revealed in the mounting bracket and can be accessed.
- Insert the device into the panel cut-out and fasten it with four screws. For dimensional drawings, refer to Section 4.25.
- Mount the 2 covers again.
- Connect a solid low-ohmic protective and operational ground to the grounding terminal of the device. The cross-section of the cable used must correspond to the maximum connected cross-section but must be at least 2.5 mm².
- Connections are to be established via the screw terminals on the rear panel of the device in accordance with the circuit diagram. The details on the connection technique for the communication modules at the bottom of the device (port A and port B) in accordance with the SIPROTEC 4 System Description and the details on the connection technique for the current and voltage terminals on the rear of the device in the Sections „Connections of the Current Terminals“ and „Connections of the Voltage Terminals“ must be strictly observed.

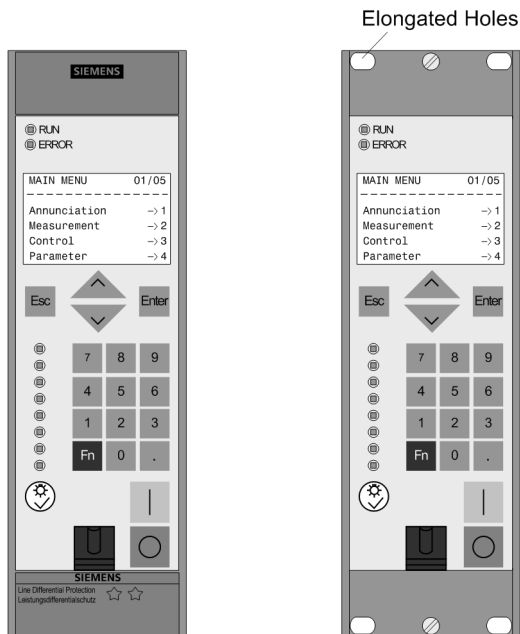

Figure 3-13 Panel flush mounting of a 7SJ80

3.1.3.3 Cubicle Mounting

To install the device in a rack or cubicle, two mounting brackets are required. The ordering codes are stated in Appendix, Section A.1.

The housing (housing size $\frac{1}{6}$) has 2 covers and 4 fixing holes.

- Loosely screw the two angle rails into the rack or cubicle with 4 screws each.
- Remove the 2 covers at the top and bottom of the front cover. Thus, 4 elongated holes are revealed in the mounting bracket and can be accessed.
- Secure the device to the angle rails with 4 screws.
- Mount the 2 covers again.
- Tighten the 8 screws of the the angle rails in the rack or cubicle.
- Connect a solid low-ohmic protective and operational ground to the grounding terminal of the device. The cross-section of the cable used must correspond to the maximum connected cross-section but must be at least 2.5 mm².
- Connections are to be established via the screw terminals at the rear panel of the device in accordance with the circuit diagram. The details on the connection technique for the communication modules on the bottom of the device (port A and port B) in accordance with the SIPROTEC 4 System Description and the details on the connection technique for the current and voltage terminals at the rear of the device in the Sections „Connections of the Current Terminals“ and „Connections of the Voltage Terminals“ must be strictly observed.

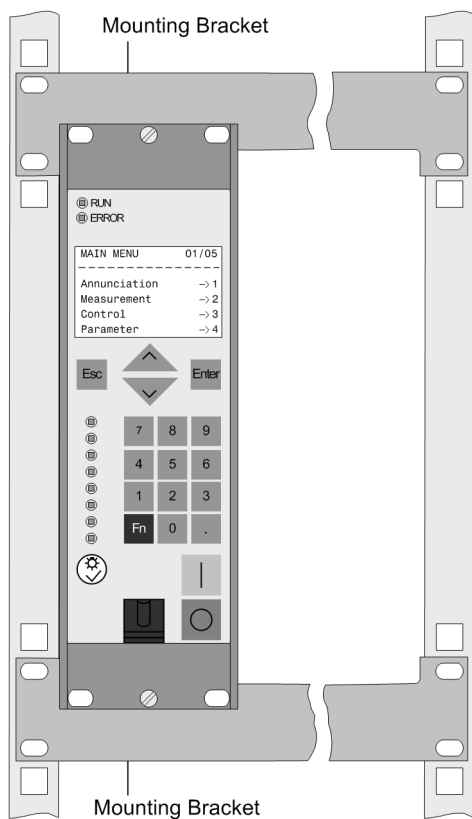

Figure 3-14 Example installation of a 7SJ80 in a rack or cubicle

3.1.3.4 Panel Surface Mounting

When ordering the device as surface-mounting case (9th digit of the ordering number= B), the mounting frame shown below is part of the scope of delivery.

For installation, proceed as follows:

- Drill the holes for the mounting frame into the control panel.
- Fasten the mounting frame with 4 screws to the control panel (the continuously open side of the mounting frame is intended for the cable harnesses and can point at the top or bottom according to customer specification).
- Loosen the terminal blocks for the wiring, wire the terminal blocks and then click them in again.
- Connect a solid low-ohmic protective and operational ground to the grounding terminal of the device. The cross-section of the cable used must correspond to the maximum connected cross-section but must be at least 2.5 mm^2 .
- Connections are to be established via the screw terminals on the rear panel of the device in accordance with the circuit diagram. The details on the connection technique for the communication modules at the bottom of the device (port A and port B) in accordance with the SIPROTEC 4 System Description and the details on the connection technique for the current and voltage terminals on the rear of the device in the Sections „Connections of the Current Terminals“ and „Connections of the Voltage Terminals“ must be strictly observed.
- Insert the device into the mounting frame (make sure that no cables are jammed).
- Secure the device to the mounting frame with 4 screws. For dimensional drawings, refer to the Technical Data, Section 4.25.

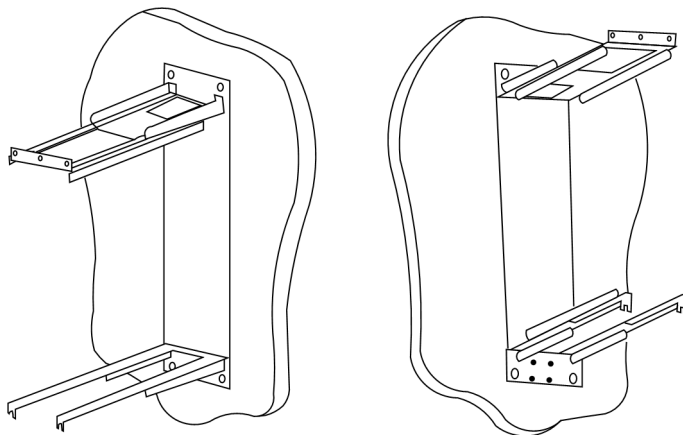

Figure 3-15 Mounting rails for panel surface mounting

3.2 Checking Connections

3.2.1 Checking the Data Connections of the Interfaces

Pin Assignment

The following tables show the pin assignment of the various interfaces. The position of the connections can be seen in the following figures.

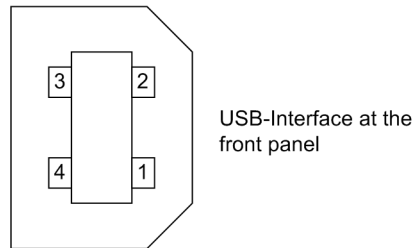

Figure 3-16 USB interface

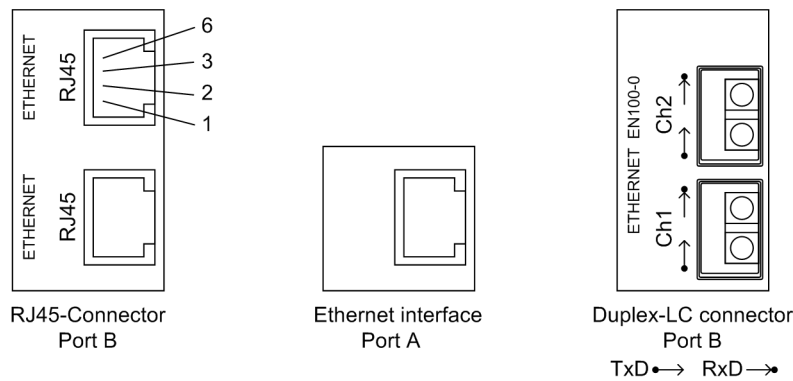
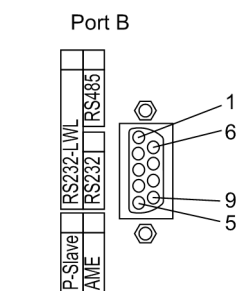

Figure 3-17 Ethernet connections at the device bottom



Serial Interface on the device bottom

Figure 3-18 Serial interface at the device bottom

USB Interface

The USB interface can be used to establish a connection between the protection device and your PC. For the communication, the Microsoft Windows USB driver is used which is installed together with DIGSI (as of version V4.82). The interface is installed as a virtual serial COM port. We recommend the use of standard USB cables with a maximum length of 5 m/16 ft.

Table 3-2 Assignment of the USB socket

Pin No.	1	2	3	4	Housing
USB	VBUS (unused)	D-	D+	GND	Shield

Connections at port A

If the interface is used for communication with the device, the data connection is to be checked.

Table 3-3 Assignment of the port A socket

Pin No.	Ethernet interface
1	Tx+
2	Tx-
3	Rx+
4	—
5	—
6	Rx-
7	—
8	—

Connections at port B

When a serial interface of the device is connected to a control center, the data connection must be checked. A visual check of the assignment of the transmit and receive channels is important. With RS232 and fiber optic interfaces, each connection is dedicated to one transmission direction. For that reason the data output of one device must be connected to the data input of the other device and vice versa.

Table 3-4 Assignment of the port B sockets

Pin No.	RS232	RS485	Profibus DP, RS485	Modbus RS485	Ethernet EN 100	IEC 60870-5-103 redundant
				DNP3.0 RS485		
1	Shield (electrically connected with shield shroud)				Tx+	B/B' (RxD/TxD-P)
2	RxD	–	–	–	Tx–	A/A' (RxD/TxD-N)
3	TxD	A/A' (RxD/TxD-N)	B/B' (RxD/TxD-P)	A	Rx+	–
4	–	–	CNTR-A (TTL)	RTS (TTL level)	–	–
5	GND	C/C' (GND)	C/C' (GND)	GND1	–	–
6	–	–	+5 V (max. load <100 mA)	VCC1	Rx–	–
7	RTS	– ¹⁾	–	–	–	–
8	CTS	B/B' (RxD/TxD-P)	A/A' (RxD/TxD-N)	B	–	–
9	–	–	–	–	not available	not available

¹⁾ Pin 7 also carries the RTS signal with RS232 level when operated as RS485 interface. Pin 7 must therefore not be connected!

With data cables, the connections are designated according to DIN 66020 and ISO 2110:

- TxD = Data output
- RxD = Data input
- $\overline{\text{RTS}}$ = Request to send
- $\overline{\text{CTS}}$ = Clear to send
- GND = Signal/Chassis Ground

The cable shield is to be grounded at **both ends**. For extremely EMC-prone environments, the GND may be connected via a separate individually shielded wire pair to improve immunity to interference.

Fiber-optic Cables



WARNING!

Laser Radiation! Class 1

Do not look directly into the fiber-optic elements!

Signals transmitted via optical fibers are unaffected by interference. The fibers guarantee electrical isolation between the connections. Transmit and receive connections are represented by symbols.

The standard setting of the character idle state for the optical fiber interface is „Light off“. If the character idle state is to be changed, use the operating program DIGSI as described in the SIPROTEC 4 System Description.

3.2.2 Checking the System Connections



WARNING!

Warning of dangerous voltages

Non-observance of the following measures can result in death, personal injury or substantial property damage.

Therefore, only qualified people who are familiar with and adhere to the safety procedures and precautionary measures should perform the inspection steps.



Caution!

Take care when operating the device without a battery on a battery charger.

Non-observance of the following measures can lead to unusually high voltages and consequently, the destruction of the device.

Do not operate the device on a battery charger without a connected battery. (For limit values see also Technical Data, Section 4.1).

If undervoltage protection is configured and enabled in the device and if, at the same time, the current criterion is disabled, the device picks up right after auxiliary voltage has been connected, since no measuring voltage is available. To make the device configurable, pickup is to be stopped, i.e. the measuring voltage is connected or voltage protection is blocked. This can be performed by operation.

Before the device is energized for the first time, it should be in the final operating environment for at least 2 hours to equalize the temperature, to minimize humidity and to avoid condensation. Connections are checked with the device at its final location. The plant must first be switched off and grounded.

Proceed as follows for checking the system connections:

- Circuit breakers for the auxiliary power supply and the measuring voltage must be opened.
- Check the continuity of all current and voltage transformer connections against the system and connection diagrams:
 - Are the current transformers grounded properly?
 - Are the polarities of the current transformer connections the same?
 - Is the phase assignment of the current transformers correct?
 - Are the voltage transformers grounded properly?
 - Are the polarities of the voltage transformer connections the same and correct?
 - Is the phase assignment of the voltage transformers correct?
 - Is the polarity for the current input I_N , I_{Ns} correct (if used)?
 - Is the polarity for the voltage input V_3 correct (if used e.g. for broken delta winding or busbar voltage)?

- If the voltage measurement is carried out via feedthrough capacitances, the feedthrough capacitance for the 7SJ80 must be available exclusively.. Parallel connections such as, for example, CAPDIS are not permissible.

In the case of a voltage measurement via feedthrough capacitances, the value of the individual capacitances C1 and C2 for the three phases must be known approximately (also see Section 2.1.3.2, „Capacitive Voltage Measurement“). These capacitance values are configured via the parameter addresses 241

Volt.trans.A:C1 to 246 **Volt.trans.C:C2** in the **Power System Data 1**. The value for the feedthrough capacitances (C1) is usually in the range from 5 pF to 10 pF. The values for the line capacitances (C2) - also including the stray capacitance - basically depend on the cable type used and the cable length for the measuring voltage connection. When entering the parameter for C2, the value of the capacitance of the voltage input has to be added. This input capacitance can be estimated as 2200 pF. Inexactly configured capacitance values will result in deviations during the measurement of the voltage amplitude and the voltage phase angle.

If the phase-selective voltages on the primary side are known (usually the nominal voltage of the system divided by $\sqrt{3}$), the values for the capacitances C1 can be optimized afterwards. The configured values of C2 can also be optimized if the phase angles between the phase-to-ground voltages and the phase currents are known. An explanation of the procedure for optimizing the input capacitances is to be found in Section 2.1.3.2, „Capacitive Voltage Measurement“.

- If test switches are used for the secondary testing of the device, their functions must also be checked, in particular that in the „Check“ position the current transformer secondary lines are automatically short-circuited.
- Connect an ammeter in the supply circuit of the power supply. A range of about 2.5 A to 5 A for the meter is appropriate.
- Switch on m.c.b. for auxiliary voltage (supply protection), check the voltage level and, if applicable, the polarity of the voltage at the device terminals or at the connection modules.
- The current input should correspond to the power input in neutral position of the device. The measured steady state current should be insignificant. Transient movement of the ammeter merely indicates the charging current of capacitors.
- Remove the voltage from the power supply by opening the protective switches.
- Disconnect the measuring test equipment; restore the normal power supply connections.
- Apply voltage to the power supply.
- Close the protective switches for the voltage transformers.
- Verify that the voltage phase rotation at the device terminals is correct.
- Open the protective switches for the voltage transformers and the power supply.
- Check the trip and close circuits to the power system circuit breakers.
- Verify that the control wiring to and from other devices is correct.
- Check the signaling connections.
- Switch the mcb back on.

3.3 Commissioning



WARNING!

Warning of dangerous voltages when operating an electrical device

Non-observance of the following measures can result in death, personal injury or substantial property damage.

Only qualified people shall work on and around this device. They must be thoroughly familiar with all warnings and safety notices in this instruction manual as well as with the applicable safety steps, safety regulations, and precautionary measures.

Before making any connections, the device must be grounded at the protective conductor terminal.

Hazardous voltages can exist in all switchgear components connected to the power supply and to measurement and test circuits.

Hazardous voltages can be present in the device even after the power supply voltage has been removed (capacitors can still be charged).

After switching off the auxiliary voltage, wait a minimum of 10 seconds before reconnecting this voltage so that steady conditions can be established.

The limit values given in Technical Data (Chapter 4) must not be exceeded, neither during testing nor during commissioning.

When testing the device with secondary test equipment, make sure that no other measurement quantities are connected and that the trip and close circuits to the circuit breakers and other primary switches are disconnected from the device.



DANGER!

Hazardous voltages during interruptions in secondary circuits of current transformers

Non-observance of the following measure will result in death, severe personal injury or substantial property damage.

Short-circuit the current transformer secondary circuits before current connections to the device are opened.

Switching operations have to be carried out during commissioning. A prerequisite for the prescribed tests is that these switching operations can be executed without danger. They are accordingly not intended for operational checks.



WARNING!

Warning of dangers evolving from improper primary tests

Non-observance of the following measures can result in death, personal injury or substantial property damage.

Primary tests are only allowed to be carried out by qualified personnel, who are familiar with the commissioning of protection systems, the operation of the plant and the safety rules and regulations (switching, grounding, etc.).

3.3.1 Test Mode and Transmission Block

Activation and Deactivation

If the device is connected to a central or main computer system via the SCADA interface, then the information that is transmitted can be influenced. This is only possible with some of the protocols available (see Table „Protocol-dependent functions“ in the Appendix A.6).

If the **test mode** is switched on, the messages sent by a SIPROTEC 4 device to the main system has an additional test bit. This bit allows the messages to be recognized as not resulting from actual faults. Furthermore, it can be determined by activating the **transmission block** that no annunciations are transmitted via the system interface during test mode.

The SIPROTEC 4 System Manual describes in detail how to activate and deactivate the test mode and blocked data transmission. Please note that when DIGSI is being used for device editing, the program must be in the **online** operating mode for the test features to be used.

3.3.2 Testing the System Interface (at Port B)

Preliminary Remarks

If the device features a system interface which is used to communicate with a control center, the DIGSI device operation can be used to test if messages are transmitted correctly. This test option should however definitely not be used while the device is in service on a live system.



DANGER!

Danger evolving from operating the equipment (e.g. circuit breakers, disconnectors) by means of the test function

Non-observance of the following measure will result in death, severe personal injury or substantial property damage.

Equipment used to allow switching such as circuit breakers or disconnectors is to be checked only during commissioning. Do not under any circumstances check them by means of the test function during real operation by transmitting or receiving messages via the system interface.



Note

After termination of the system interface test the device will reboot. Thereby, all annunciation buffers are erased. If required, these buffers should be extracted with DIGSI prior to the test.

The interface test is carried out using DIGSI in the Online operating mode:

- Open the **Online** directory by double-clicking; the operating functions for the device appear.
- Click on **Test**; the function selection appears in the right half of the screen.
- Double-click **Generate Indications** in the list view. The **Generate Indications** dialog box opens (see following figure).

Structure of the Test Dialog Box

In the column **Indication** the display texts of all indications are displayed which were allocated to the system interface in the matrix. In the column **SETPOINT Status** the user has to define the value for the messages to be tested. Depending on annunciation type, several input fields are offered (e.g. message „ON“ / message „OFF“). By clicking on one of the fields you can select the desired value from the pull-down menu.

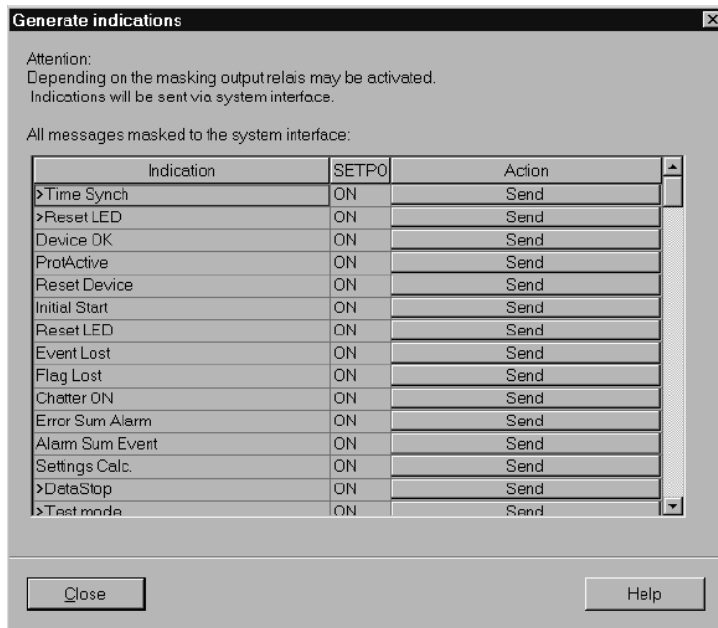

Figure 3-19 Interface test with the dialog box: creating messages – example

Changing the Operating State

When clicking one of the buttons in the column **Action** for the first time, you will be prompted for the password no. 6 (for hardware test menus). After correct entry of the password, individual annunciations can be initiated. To do so, click on the button **Send** on the corresponding line. The corresponding message is issued and can be read out either from the event log of the SIPROTEC 4 device or from the substation control system.

As long as the window is open, further tests can be performed.

Test in Message Direction

For all information that is transmitted to the central station, test the options in the list which appears in **SET-POINT Status**:

- Make sure that each checking process is carried out carefully without causing any danger (see above and refer to DANGER!)
- Click on Send in the function to be tested and check whether the transmitted information reaches the central station and shows the desired reaction. Data which are normally linked via binary inputs (first character „>“) are likewise indicated to the central power system with this procedure. The function of the binary inputs itself is tested separately.

Exiting the Test Mode

To end the System Interface Test, click on **Close**. The device is briefly out of service while the start-up routine is executed. The dialog box closes.

Test in Command Direction

The information transmitted in command direction must be indicated by the central station. Check whether the reaction is correct.

3.3.3 Configuring Communication Modules

Required Settings in DIGSI 4

The following applies in general:

In the case of a first-time installation or replacement of a communication module, the ordering number (MLFB) does not need to be changed. The ordering number can be retained. Thus, all previously created parameter sets remain valid for the device.

Changes in the DIGSI Manager

In order that the protection device can access the new communication module, a change has to be made in the parameter set within the DIGSI Manager.

Mark the SIPROTEC device in your project in **DIGSI 4 Manager** and choose the menu entry "Edit" - "Object Properties" to open the dialog box „Properties – SIPROTEC 4 Device“ zu öffnen (see pict. 3-20). In the properties box „communications module“ for „11. Port B“ (on back of device bottom) and for „12. Port A“ (on front of device bottom) an interface has to be selected via the Pull-Down button. The entry „further protocols, see addition L“ has to be selected for Profibus DP, Modbus or DNP3.0.

The type of communication module for port B is to be stated in the dialog box "Additional information" which can be reached via the pushbutton "L: ...".

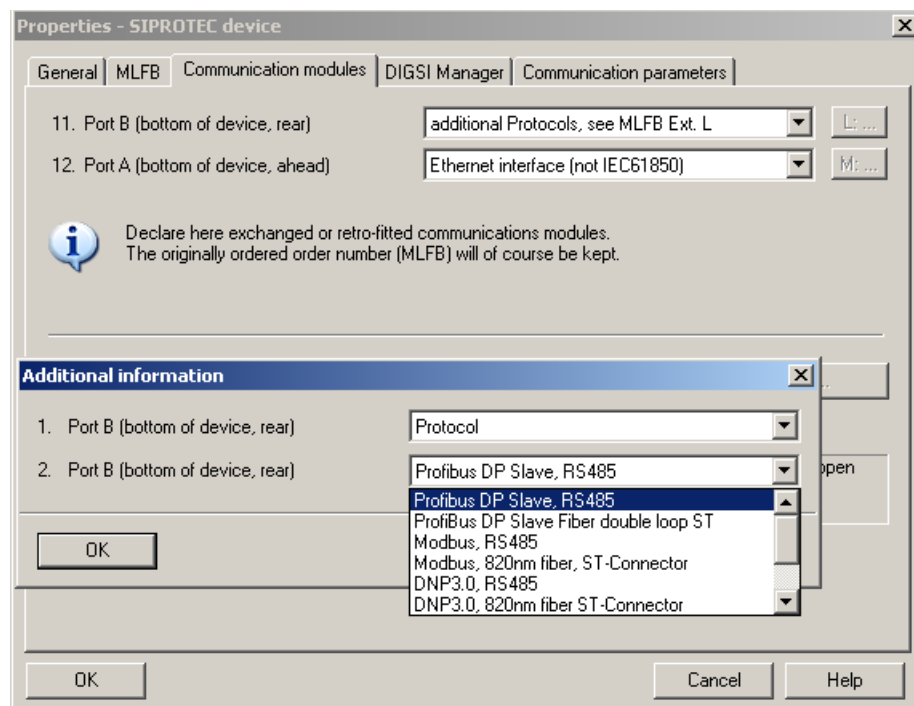

Figure 3-20 DIGSI 4.3: Profibus DP protocol selection (example)

Mapping File

For Profibus DP, Modbus, DNP3.0 and VDEW Redundant, a matching bus mapping has to be selected.

For the selection of the mapping file please open the SIPROTEC device in DIGSI and choose the function „Interfaces“ in „Parameter“ (see pict. 3-21).

The dialog box "**Interface parameters**" offers the following dialog elements in the properties tab "**Additional protocols on the device**":

- Display of the selected communication module
- Selection box "**Mapping file**" listing all Profibus DP, Modbus, DNP3.0 and VDEW Redundant mapping files available for the respective device type, with their names and reference to the corresponding bus mapping document
- Edit field "**Module-specific settings**" for changing the bus-specific parameters

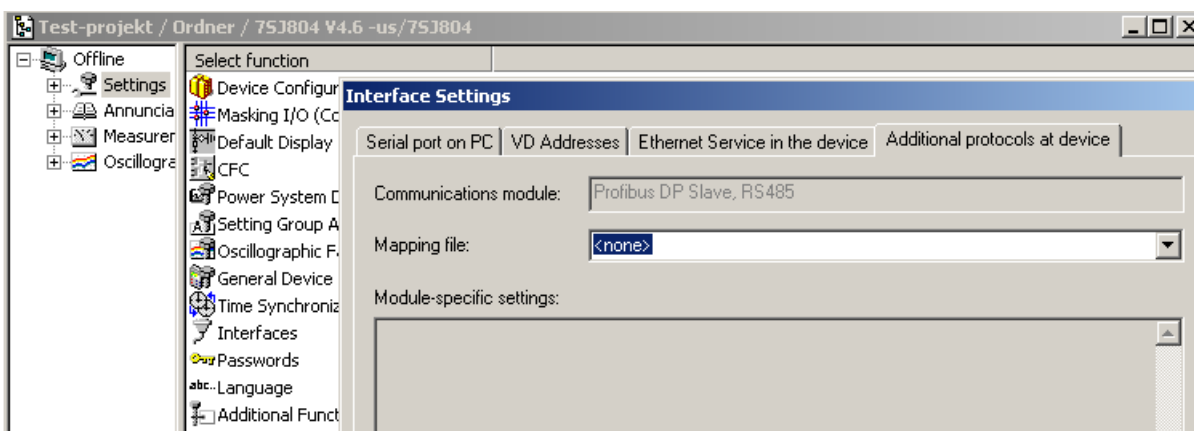

Figure 3-21 DIGSI 4.3: Selection of a mapping file and setting of bus-specific parameters



Note

If the mapping file assignment for a SIPROTEC device has been changed, this is usually connected with a change of the allocations of the SIPROTEC objects to the system interface.

After having selected a new mapping file, please check the allocations to "Target system interface" or "Source system interface" in the **DIGSI allocation matrix**.

Edit Field "Module-specific settings"

In the edit field "Module-specific settings", only change the numbers in the lines not starting with "/" and observe the semicolon at the end of the lines.

Further changes in the edit field might lead to an error message when closing the dialog box "**Interface parameters**".

Please select the bus mapping corresponding to your requirements. The documentation of the individual bus mappings is available on the Internet (www.siprotec.com in the download area).

After having selected the bus mapping, the area of the mapping file in which you can make device-specific settings appears in the window (see Figure 3-22). The type of this setting depends of the protocol used and is described in the protocol documentation. Please only perform the described changes in the settings window and confirm your entries with "OK".

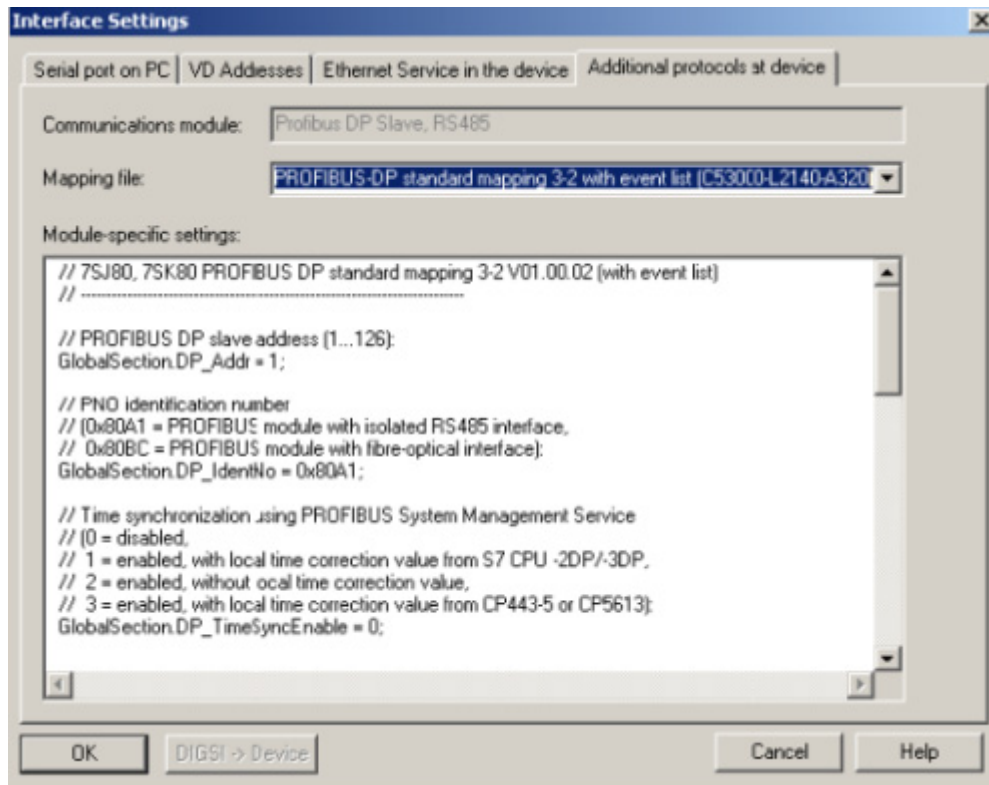

Figure 3-22 Module-specific settings

Then, transfer the data to the protection device (see the following figure).

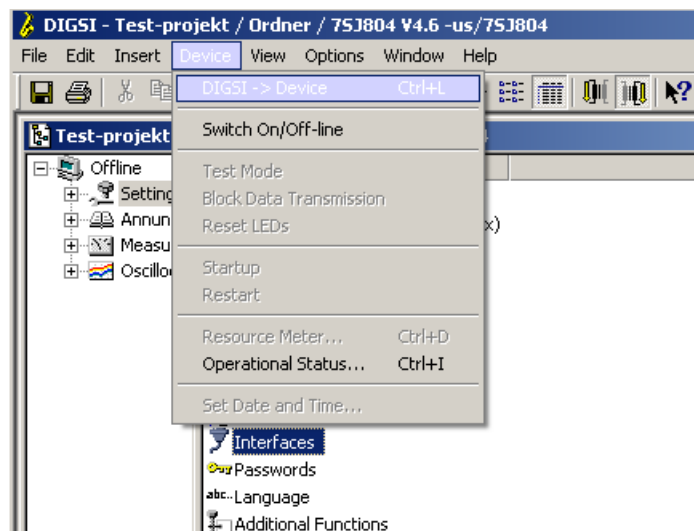

Figure 3-23 Transmitting data

Terminal Test

The system interface (EN 100) is preassigned with the default value zero and the module is thus set to DHCP mode. The IP address can be set in the DIGSI Manager (Object properties... / Communication parameters / System interface [Ethernet]).

The Ethernet interface is preassigned with the following IP address and can be changed on the device at any time (DIGSI device processing / Parameters / Interfaces / Ethernet service):

IP address: 192.168.100.10

Network mask: 255.255.255.0

The following restrictions must be observed:

For subnet mask: 255.255.255.0 the IP bandwidth 192.168.64.xx is not available.

For subnet mask 255.255.255.0, the IP-Band 192.168.1.xx is not available

For subnet mask: 255.255.0.0 the IP bandwidth 192.168.xx.xx is not available.

For subnet mask: 255.0.0.0 the IP band 192.xx.xx.xx is not available.

3.3.4 Checking the Status of Binary Inputs and Outputs

Prefacing Remarks

The binary inputs, outputs, and LEDs of a SIPROTEC 4 device can be individually and precisely controlled in DIGSI. This feature is used to verify control wiring from the device to plant equipment (operational checks) during commissioning. This test option should however definitely not be used while the device is in „real“ operation.



DANGER!

Danger evolving from operating the equipment (e.g. circuit breakers, disconnectors) by means of the test function

Non-observance of the following measure will result in death, severe personal injury or substantial property damage.

Equipment used to allow switching such as circuit breakers or disconnectors is to be checked only during commissioning. Do not under any circumstances check them by means of the test function during real operation by transmitting or receiving messages via the system interface.



Note

After finishing the hardware tests, the device will reboot. Thereby, all annunciation buffers are erased. If required, these buffers should be read out with DIGSI and saved prior to the test.

The hardware test can be carried out using DIGSI in the Online operating mode:

- Open the **Online** directory by double-clicking; the operating functions for the device appear.
- Click on **Test**; the function selection appears in the right half of the screen.
- Double-click in the list view on **Hardware Test**. The dialog box of the same name opens (see the following figure).

Structure of the Test Dialog Box

The dialog box is classified into three groups: **BI** for binary inputs, **REL** for output relays, and **LED** for light-emitting diodes. On the left of each of these groups is an accordingly labeled button. By double-clicking a button, information regarding the associated group can be shown or hidden.

In the column **Status** the present (physical) state of the hardware component is displayed. Indication is made by symbols. The physical actual states of the binary inputs and outputs are indicated by an open or closed switch symbol, the LEDs by a dark or illuminated LED symbol.

The opposite state of each element is displayed in the column **Scheduled**. The display is made in plain text.

The right-most column indicates the commands or messages that are configured (masked) to the hardware components.

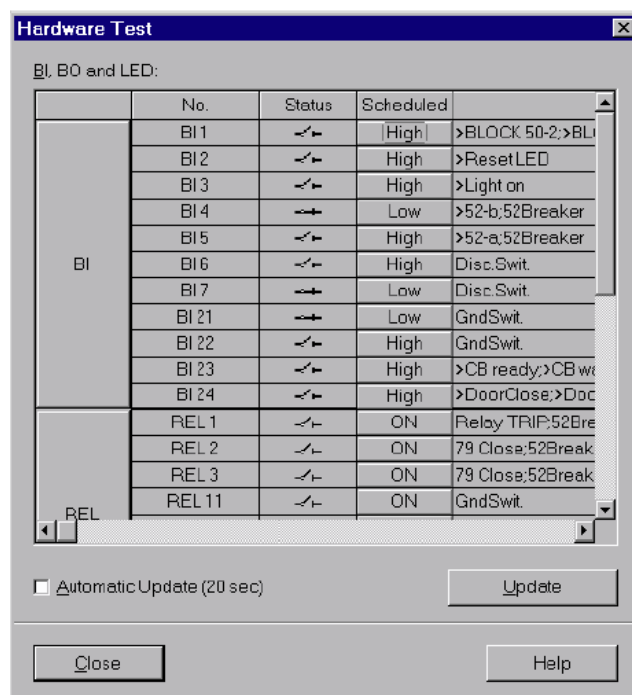

Figure 3-24 Testing the inputs and outputs

Changing the Operating State

To change the status of a hardware component, click on the associated button in the **Scheduled** column.

Password No. 6 (if activated during configuration) will be requested before the first hardware modification is allowed. After entry of the correct password a status change will be executed. Further status changes remain possible while the dialog box is open.

Test of the Output Relays

Each individual output relay can be energized for checking the wiring between the output relay of the 7SJ80 and the substation, without having to generate the message assigned to it. As soon as the first change of state for any one of the output relays is initiated, all output relays are separated from the internal device functions and can only be operated by the hardware test function. This for example means that a switching command coming from a protection function or a control command from the operator panel to an output relay cannot be executed.

Proceed as follows in order to check the output relay:

- Ensure that the switching of the output relay can be executed without danger (see above under DANGER!).
- Each output relay must be tested via the corresponding **Scheduled**-cell in the dialog box.
- Finish the testing (see margin title below „Exiting the Test Mode“), so that during further testings no unwanted switchings are initiated.

Test of the Binary Inputs

To test the wiring between the substation and the binary inputs of the 7SJ80, the condition in the substation which initiates the binary input must be generated and the response of the device checked.

To do so, the dialog box **Hardware Test** must be opened again to view the physical state of the binary inputs. The password is not yet required.

Proceed as follows in order to check the binary inputs:

- Activate each of function in the system which causes a binary input to pick up.
- Check the reaction in the **Status** column of the dialog box. To do so, the dialog box must be updated. The options may be found below under the margin heading „Updating the Display“.
- Finish the testing (see margin heading below „Exiting the Test Mode“).

If ,however, the effect of a binary input must be checked without carrying out any switching in the plant, it is possible to trigger individual binary inputs with the hardware test function. As soon as the first state change of any binary input is triggered and the password No. 6 has been entered, all binary inputs are separated from the plant and can only be activated via the hardware test function.

Test of the LEDs

The LEDs may be tested in a similar manner to the other input/output components. As soon as the first state change of any LED has been triggered, all LEDs are separated from the internal device functionality and can only be controlled via the hardware test function. This means e.g. that no LED is illuminated anymore by a protection function or by pressing the LED reset button.

Updating the Display

As the **Hardware Test** dialog opens, the operating states of the hardware components which are current at this time are read in and displayed.

An update is made:

- for each hardware component, if a command to change the condition is successfully performed,
- for all hardware components if the **Update** button is clicked,
- for all hardware components with cyclical updating (cycle time is 20 seconds) if the **Automatic Update (20sec)** field is marked.

Exiting the Test Mode

To end the hardware test, click on **Close**. The dialog box is closed. The device becomes unavailable for a brief start-up period immediately after this. Then all hardware components are returned to the operating conditions determined by the plant settings.

3.3.5 Tests for Breaker Failure Protection

General

If the device provides a breaker failure protection and if this is used, the integration of this protection function in the system must be tested under practical conditions.

Due to the variety of application options and the available system configurations, it is not possible to make a detailed description of the necessary tests. It is important to observe local conditions and protection and system drawings.

Before starting the circuit breaker tests it is recommended to isolate the circuit breaker of the tested feeder at both ends, i.e. line isolators and busbar isolators should be open so that the breaker can be operated without risk.



Caution!

Also for tests on the local circuit breaker of the feeder a trip command to the surrounding circuit breakers can be issued for the busbar.

Non-observance of the following measure can result in minor personal injury or property damage.

Therefore, primarily it is recommended to interrupt the tripping commands to the adjacent (busbar) breakers, e.g. by interrupting the corresponding pickup voltages.

Before the breaker is finally closed for normal operation, the trip command of the feeder protection routed to the circuit breaker must be disconnected so that the trip command can only be initiated by the breaker failure protection.

Although the following lists do not claim to be complete, they may also contain points which are to be ignored in the current application.

Auxiliary Contacts of the CB

The circuit breaker auxiliary contact(s) form an essential part of the breaker failure protection system in case they have been connected to the device. Make sure the correct assignment has been checked.

External Initiation Conditions

If the breaker failure protection can be started by external protection devices, the external start conditions must be checked.

In order for the breaker failure protection to be started, a current must flow at least via the monitored phase. This may be a secondary injected current.

- Start by trip command of the external protection: binary input functions „>50BF ext SRC“ (FNo 1431) (in spontaneous or fault annunciations).
- After every start, the message „50BF ext Pickup“ (FNo 1457) must appear in the spontaneous or fault annunciations.
- After time expiration **TRIP-Timer** (address 7005) tripping command of the breaker failure protection.

Switch off test current.

If start is possible without current flow:

- Closing the circuit breaker to be monitored to both sides with the disconnecter switches open.
- Start by trip command of the external protection: Binary input functions „>50BF ext SRC“ (FNo 1431) (in spontaneous or fault annunciations).

- After every start, the message „50BF ext Pickup“ (FNo 1457) must appear in the spontaneous or fault annunciations.
- After time expiration **TRIP-Timer** (address 7005) tripping command of the breaker failure protection.

Open the circuit breaker again.

Busbar Tripping

For testing the distribution of the trip commands in the substation in the case of breaker failures it is important to check that the trip commands to the adjacent circuit breakers are correct.

The adjacent circuit breakers are those of all feeders which must be tripped in order to ensure interruption of the fault current should the local breaker fail. These are therefore the circuit breakers of all feeders which feed the busbar or busbar section to which the feeder with the fault is connected.

A general detailed test guide cannot be specified because the layout of the adjacent circuit breakers largely depends on the system topology.

In particular with multiple busbars, the trip distribution logic for the adjacent circuit breakers must be checked. Here it should be checked for every busbar section that all circuit breakers which are connected to the same busbar section as the feeder circuit breaker under observation are tripped, and no other breakers.

Termination

All temporary measures taken for testing must be undone, e.g. especially switching states, interrupted trip commands, changes to setting values or individually switched off protection functions.

3.3.6 Testing User-Defined Functions

CFC Logic

The device has a vast capability for allowing functions to be defined by the user, especially with the CFC logic. Any special function or logic added to the device must be checked.

Of course, general test procedures cannot be given. Configuration of these functions and the target conditions must be actually known beforehand and tested. Possible interlocking conditions of switching devices (circuit breakers, disconnectors, ground switch) are of particular importance. They must be observed and tested.

3.3.7 Current, Voltage, and Phase Rotation Testing

Preliminary Remark



Note

The voltage and phase rotation test is only relevant for devices with voltage transformers.

≥ 10 % of Load Current

The connections of the current and voltage transformers are tested using primary quantities. Secondary load current of at least 10 % of the nominal current of the device is necessary. The line is energized and will remain in this state during the measurements.

With proper connections of the measuring circuits, none of the measured-values supervision elements in the device should pick up. If an element detects a problem, the causes which provoked it may be viewed in the Event Log. If current or voltage summation errors occur, then check the matching factors.

Messages from the symmetry monitoring could occur because there actually are asymmetrical conditions in the network. If these asymmetrical conditions are normal service conditions, the corresponding monitoring functions should be made less sensitive.

Current and Voltage Values

Currents and voltages can be seen in the display field on the front of the device or the operator interface via a PC. They can be compared to the quantities measured by an independent source, as primary and secondary quantities.

If the measured values are not plausible, the connection must be checked and corrected after the line has been isolated and the current transformer circuits have been short-circuited. The measurements must then be repeated.



Note

If the voltage measurement is carried out via feed through capacitances, the display of the values of the phase-to-ground voltages and phase angle between the phase-to-ground voltages and the phase currents can be used to optimize the configured capacitance values afterwards and to achieve an improvement of the measuring accuracy. An explanation of the procedure for optimizing the input capacitances is to be found in Section 2.1.3.2, „Capacitive Voltage Measurement“.

Phase Rotation

The phase rotation must correspond to the configured phase rotation, in general a clockwise phase rotation. If the system has an anti-clockwise phase rotation, this must have been considered when the power system data was set (address 209 **PHASE SEQ.**). If the phase rotation is incorrect, the alarm „Fail Ph. Seq.“ (FNo 171) is generated. The measured value phase allocation must be checked and corrected, if required, after the line has been isolated and current transformers have been short-circuited. The measurement must then be repeated.

Voltage Transformer Miniature Circuit Breaker (VT mcb)

The VT mcb of the feeder (if used) must be opened. The measured voltages in the operational measured values appear with a value close to zero (small measured voltages are of no consequence).

Check in the spontaneous annunciations that the VT mcb trip was entered (annunciation „>FAIL:FEEDER VT“ „ON“ in the spontaneous annunciations). Beforehand it has to be assured that the position of the VT mcb is connected to the device via a binary input.

Close the VT mcb again: The above messages appear under the spontaneous messages as „OFF“, i.e. „>FAIL:FEEDER VT“ „OFF“.

If one of the events does not appear, the connection and allocation of these signals must be checked.

If the „ON“-state and „OFF“-state are swapped, the contact type (H-active or L-active) must be checked and remedied.

3.3.8 Test for High Impedance Protection

Polarity of Transformers

When using the high impedance protection, the current corresponds to the fault current in the protection object. It is essential in this case that all current transformers feeding the resistor whose current is measured at I_{Ns} have the same polarity. Through-flowing currents are used for that. Each of the current transformers has to be included in a measurement. The current at I_{Ns} must never exceed half the pickup value of the single-phase overcurrent protection.

3.3.9 Testing the Reverse Interlocking Scheme

(only if used)

Testing reverse interlocking is available if at least one of the binary inputs available is configured for this purpose (e.g. presetting of binary input BI1 „>BLOCK 50-2“ and „>BLOCK 50N-2“ to open circuit system). Tests can be performed with phase currents or ground current. For ground current the corresponding ground current settings apply.

Please note that the blocking function can either be configured for the pickup current connected (open circuit system) or the pickup current missing (closed circuit system). For open circuit system the following tests are to be proceeded:

The feeder protection relays of all associated feeders must be in operation. At the beginning no auxiliary voltage is fed to the reverse interlocking system.

A test current higher than the pickup values of **50-2 PICKUP** and **50-1 PICKUP** or **51 PICKUP** is set. As a result of the missing blocking signal, the protection function trips after (short) time delay **50-2 DELAY**.

Caution!



Test with currents above 20 A continuous current cause an overload of the input circuits.

Perform the test only for a short time (see Technical Data, Section 4.1). Afterwards, the device has to cool off!

The direct voltage for reverse interlocking is now switched on to the line. The precedent test is repeated, the result will be the same.

Subsequently, at each of the protection devices of the feeders, a pickup is simulated. Meanwhile, another fault is simulated for the protection function of the infeed, as described before. Tripping is performed within time **50-1 DELAY** (longer time period) (with definite time overcurrent protection) or according to Curve (with inverse time overcurrent protection).

These tests also check the proper functioning of the wiring for reverse interlocking.

3.3.10 Direction Check with Load Current

Preliminary Remark



Note

The direction check is only relevant for devices with voltage transformers.

≥ 10 % of Load Current

The correct connection of the current and voltage transformers is tested via the protected line using the load current. For this purpose, connect the line. The load current the line carries must be at least $0.1 \cdot I_{Nom}$. The load current should be in-phase or lagging the voltage (resistive or resistive-inductive load). The direction of the load current must be known. If there is any doubt, network or ring loops should be opened. The line remains energized during the test.

The direction can be derived directly from the operational measured values. Initially the correlation of the measured load direction with the actual direction of load flow is checked. In this case the normal situation is assumed whereby the forward direction (measuring direction) extends from the busbar towards the line

- P** positive, if active power flows into the line,
- P** negative, if active power flows towards the busbar,
- Q** positive, if reactive power flows into the line,
- Q** negative, if reactive power flows toward the busbar.

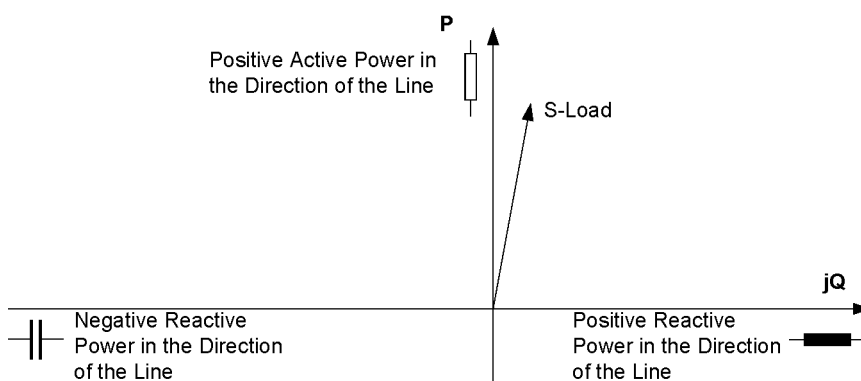

Figure 3-25 Apparent Load Power

All signs of powers may be inverted deliberately. Check whether polarity is inverted in address 1108 **P,Q sign** in the **P.System Data 2**. In that case the signs for active and reactive power are inverse as well.

The power measurement provides an initial indication as to whether the measured values have the correct polarity. If both the active power and the reactive power have the wrong sign and 1108 **P,Q sign** is set to **not reversed**, the polarity according to address 201 **CT Starpoint** must be checked and corrected.

However, power measurement itself is not able to detect all connection errors. For this reason, directional messages should be generated by means of the directional overcurrent protection. Therefore, pickup thresholds must be reduced so that the available load current causes a continuous pickup of the element. The direction reported in the messages, such as „Phase A forward“ or „Phase A reverse“ must correspond to the actual power flow. Be careful that the „Forward“ direction of the protective element is in the direction of the line

(or object to be protected). This is not necessarily identical with the direction of the normal the power flow. For all three phases, the directional messages to the power flow must be reported properly.

If all directions differ from each other, individual phases in current or voltage transformer connections are interchanged, not connected properly or phase assignment is incorrect. After isolation of the line and short-circuiting of the current transformers the connections must be checked and corrected. The measurements must then be repeated.

Finally, switch off the protected power line.



Note

Reset the pickup values changed for the check to valid values.

3.3.11 Polarity Check for Voltage Input V_3

Depending on the application of the voltage measuring input V_3 of a 7SJ80, a polarity check may be necessary. If no measuring voltage is connected to this input, this section is irrelevant.

If input V_3 is used for the measurement of the **displacement voltage V_N** (Power System Data 1 address 213 **VT Connect. 3ph = V_{ab} , V_{bc} , V_{Gnd}**), the polarity is checked together with the current input I_N/I_{Ns} (see further below).

If the input V_3 is used for measuring a voltage for **synchrocheck** (Power System Data 1, address 213 **VT Connect. 3ph = V_{ab} , V_{bc} , V_{Syn} or V_{ph-g} , V_{Syn}**), the following is to be observed:

- The single-phase voltage V_2 to be synchronized must be connected to input V_3 .
- The correct polarity is to be checked as follows using the synchrocheck function:

The device must provide the synchrocheck function which is to be configured in address 161 = **25 Function 1 = SYNCHROCHECK**.

The voltage V_2 to be synchronized must be set correctly in address 6123 **CONNECTIONof V2**.

If a transformer is located between the measuring points of the reference voltage V_1 and the voltage to be synchronized V_2 , its phase rotation must be taken into consideration. For this purpose, a corresponding angle is entered in address 6122 **ANGLE ADJUSTM.**, in the direction of the busbar seen from the feeder. An example is shown in Section 2.20.

If necessary different transformation ratios of the transformers on the busbar and the feeder may have to be considered under address **Balancing V1/V2**.

The synchrocheck function must be activated at address 6101 **Synchronizing = ON**.

A further aid for checking the connections are the messages 170.2090 „25 $V_2 > V_1$ “, 170.2091 „25 $V_2 < V_1$ “, 170.2094 „25 $\alpha_2 > \alpha_1$ “ and 170.2095 „25 $\alpha_2 < \alpha_1$ “ in the spontaneous messages.

- Circuit breaker is open. The feeder is de-energized. The circuit breakers of both voltage transformer circuits must be closed.
- For the synchrocheck, the program **Direct C0** is set to **YES** (address 6110); the other programs (addresses 6107 to 6109) are set to **NO**.
- Via a binary input (170.0043 „>25 Sync requ.“) a measurement request is entered. The synchrocheck must release closing (message 170.0049 „25 CloseRelease“). If not, check all relevant parameters again (synchrocheck configured and enabled correctly, see Sections 2.1.1 and 2.20).
- Set address 6110 **Direct C0** to **NO**.
- Then the circuit breaker is closed while the line isolator is open (see Figure 3-26). Thus, both voltage transformers receive the same voltage.
- For the synchrocheck, the program **25 Function 1** is set to **SYNCHROCHECK** (address 161)

- Via a binary input (170.0043 „>25 Sync requ.“) a measurement request is entered. The synchrocheck must release closing (message „25 CloseRelease“, 170.0049).
- If not, first check whether one of the aforesaid messages 170.2090 „25 V2>V1“ or 170.2091 „25 V2<V1“ or 170.2094 „25 $\alpha_2 > \alpha_1$ “ or 170.2095 „25 $\alpha_2 < \alpha_1$ “ is available in the spontaneous messages.
The message „25 V2>V1“ or „25 V2<V1“ indicates that the magnitude adaption is incorrect. Check address 6121 **Balancing V1/V2** and recalculate the adaptation factor.
The message „25 $\alpha_2 > \alpha_1$ “ or „25 $\alpha_2 < \alpha_1$ “ indicates that the phase relation of the busbar voltage does not match the setting under address **CONNECTION of V2** (see Section 2.20). When measuring via a transformer, address 6122 **ANGLE ADJUSTM.** must also be checked; this must adapt the vector group. If these are correct, there is probably a reverse polarity of the voltage transformer terminals for V₁.
- For the synchrocheck, the program **SYNC V1>V2<** is set to **YES** (address 6108)
- Open the VT mcb of the busbar voltage.
- Via a binary input (170.0043 „>25 Sync requ.“) a measurement request is entered. There is no close release. If there is, the VT mcb for the busbar voltage is not allocated. Check whether this is the required state, alternatively check the binary input „>FAIL: BUS VT“ (6510).
- Close the VT mcb of the busbar voltage again.
- Open the circuit breaker.
- For the synchrocheck, the program **SYNC V1<V2>** is set to **YES** (address 6107) and **SYNC V1>V2<** is set to **NO** (address 6108).
- Via a binary input (170.0043 „>25 Sync requ.“) a measurement request is entered. The synchrocheck must release closing (message „25 CloseRelease“, 170.0049). Otherwise check all voltage connections and the corresponding parameters again thoroughly as described in Section 2.20.
- Open the VT mcb of the feeder voltage.
- Via a binary input (170.0043 „>25 Sync requ.“) a measurement request is entered. No close release is given.
- Close the VT mcb of the busbar voltage again.

Addresses 6107 to 6110 must be restored as they were changed for the test. If the allocation of the LEDs or signal relays was changed for the test, this must also be restored.

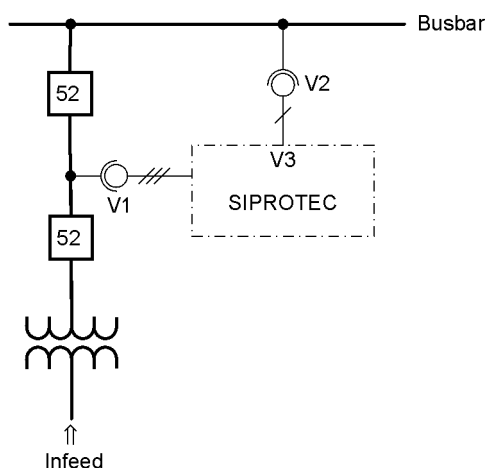

Figure 3-26 Measuring voltages for synchrocheck

3.3.12 Ground Fault Check

Ungrounded Systems

The ground fault check is only necessary if the device is connected to an isolated or resonant-grounded system and the ground fault detection is applied. The device must thus have been preset during configuration of the device functions to **Sens. Gnd Fault = Enabled** (address 131). In all other cases, this section is irrelevant. Ground fault direction detection only works with devices in which the 15th digit of the is B or C.

The primary check serves to find out the correct polarity of the transformer connections for the determination of the ground fault direction.



DANGER!

Energized equipment of the power system ! Capacitive coupled voltages at disconnected equipment of the power system !

Non-observance of the following measure will result in death, severe personal injury or substantial property damage.

Primary measurements must only be carried out on disconnected and grounded equipment of the power system !

Using the primary ground fault method a most reliable test result is guaranteed. Therefore please proceed as follows:

- Isolate the line and ground it on both ends. During the whole testing procedure the line must be open at the remote end.
- Make a test connection between a single phase and ground. On overhead lines it can be connected anywhere, however, it must be located behind the current transformers (looking from the busbar of the feeder to be checked). Cables are grounded on the remote end (sealing end).
- Remove the protective grounding of the line.
- Connect a circuit breaker to the line end that is to be tested.
- Check the direction indication (LED if allocated)
- The faulty phase (FNo 1272 for A or 1273 for B or 1274 for C) and the direction of the line, i.e. „SensGnd Forward“ (FNo 1276) must be indicated in the ground fault protocol.
- The active and reactive components of the ground current are also indicated („INs Reac“, FNo. 702). The reactive current „INs Rea1“, FNo. 701) is the most relevant for isolated systems. If the display shows the message „SensGnd Reverse“ (FNo. 1277), either the current or voltage transformer terminals are swapped in the neutral path. If message „SensGnd undef.“ (FNo 1278) appears, the ground current may be too low.
- Deenergize and ground the line.

The test is then finished.

3.3.13 Polarity Check for Current Input I_N

General

If the standard connection of the device is used with current input I_N connected in the neutral point of the set of current transformers (see also connection circuit diagram in Appendix A.3), then the correct polarity of the ground current path usually occurs automatically.

If, however, current I_N is derived from a separate summation CT (see e.g. a connection circuit diagram in the Appendix A.3), an additional direction check with this current is necessary.

If the device features the sensitive current input for I_N and if it is used in an isolated or resonant-grounded system, the polarity check for I_N was already carried out with the ground fault check according to the previous section. Then this section is not relevant.

Otherwise the test is done with a disconnected trip circuit and primary load current. It must be noted that during all simulations that do not exactly correspond with situations that may occur in practice, the non-symmetry of measured values may cause the measured value monitoring to pick up. This must therefore be ignored during such tests.



DANGER!

Hazardous voltages during interruptions in secondary circuits of current transformers

Non-observance of the following measure will result in death, severe personal injury or substantial property damage.

Short-circuit the current transformer secondary circuits before current connections to the device are opened.

Directional Testing for Grounded Systems

The check can either be carried out with function „directional ground fault protection“ (address 116) or with the function „ground fault detection“ (address 131), which can be operated as additional fault protection.

In the following the check is described using the „directional ground fault protection“ function (address 116) as an example.

To generate a displacement voltage, the e–n winding of one phase in the voltage transformer set (e.g. A) is bypassed (see Figure 3-27). If no connection on the e–n windings of the voltage transformer is provided, the corresponding phase is disconnected on the secondary side (see Figure 3-28). Only the current of the transformer which is not provided with voltage in its voltage path is fed into the current path. If the line carries resistive-inductive load, the protection is subject to the same conditions as exist during a ground fault in line direction.

The directional ground fault protection must be configured to enabled and activated (address 116 or 131). Its pickup threshold must be below the load current of the line; if necessary the pickup threshold must be reduced. The parameters that have been changed, must be noted.

After switching the line on and off again, the direction indication must be checked: In the fault log the messages „67N picked up“ and „Ground forward“ must at least be present. If the directional pickup is not present, either the ground current connection or the displacement voltage connection is incorrect. If the wrong direction is indicated, either the direction of load flow is from the line toward the busbar or the ground current path has a swapped polarity. In the latter case, the connection must be rectified after the line has been isolated and the current transformers short-circuited.

If the pickup message is missing, the measured ground (residual) current or the displacement voltage emerged may be too small. This can be checked via operational measured values.

Important! If parameters were changed for this test, they must be returned to their original state after completion of the test !

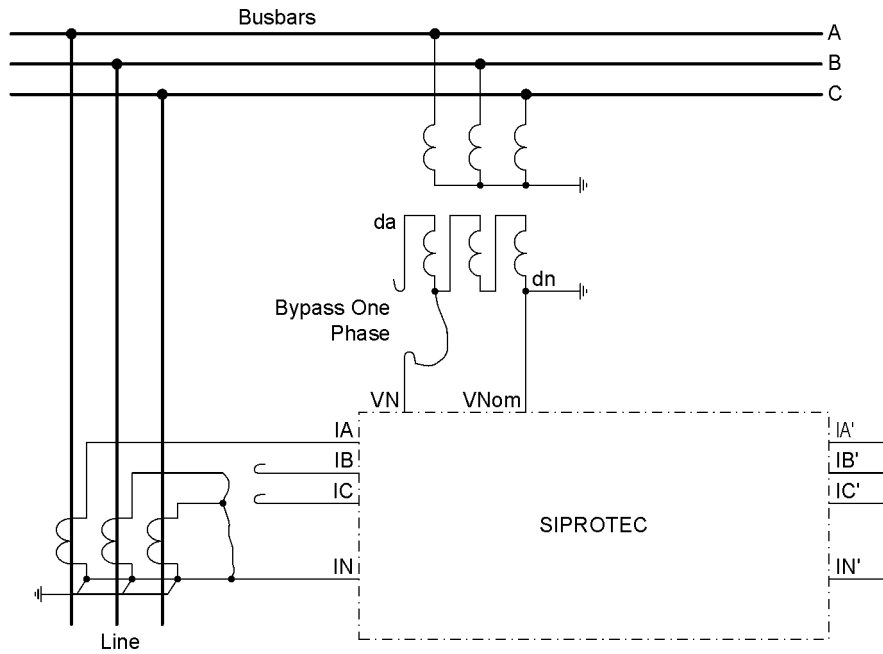

Figure 3-27 Polarity testing for I_N , example with current transformers configured in a Holmgreen-connection (VTs with broken delta connection -- e-n winding)

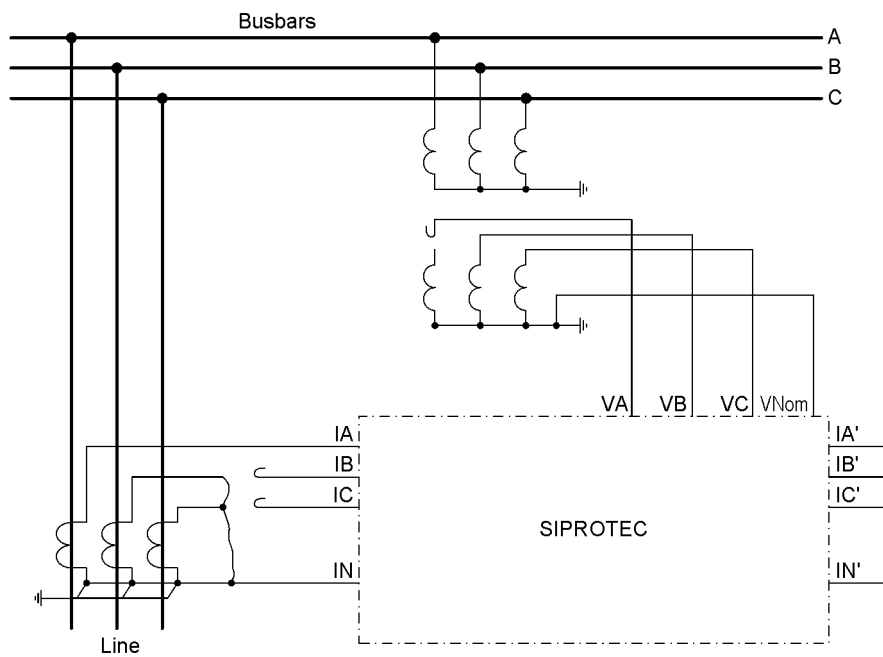

Figure 3-28 Polarity testing for I_N , example with current transformers configured in a Holmgreen-connection (VTs Wye-connected)

3.3.14 Trip/Close Tests for the Configured Operating Devices

Control by Local Command

If the configured equipment was not switched sufficiently in the hardware test already described, configured equipment must be switched on and off from the device via the integrated control element. The feedback information on the circuit breaker position injected via binary inputs is to be read out at the device and compared with the actual breaker position.

The switching procedure is described in the SIPROTEC 4 System Description. The switching authority must be set according to the command source used. The switching mode can be selected from interlocked and non-interlocked switching. Please note that non-interlocked switching can be a safety hazard.

Control by Protective Functions

For OPEN-commands sent to the circuit breaker please take into consideration that if the internal or external automatic reclosure function is used a TRIP-CLOSE test cycle is initiated.



DANGER!

A test cycle successfully started by the automatic reclosure function can lead to the closing of the circuit breaker !

Non-observance of the following statement will result in death, severe personal injury or substantial property damage.

Be fully aware that OPEN-commands sent to the circuit breaker can result in a trip-close-trip event of the circuit breaker by an external reclosing device.

Control from a Remote Control Center

If the device is connected to a remote substation via a system interface, the corresponding switching tests may also be checked from the substation. Please also take into consideration that the switching authority is set in correspondence with the source of commands used.

3.3.15 Creating Oscillographic Recordings for Tests

General

In order to be able to test the stability of the protection during switchon procedures also, switchon trials can also be carried out at the end. Oscillographic records obtain the maximum information about the behaviour of the protection.

Requirements

To be able to trip a test fault record, parameter **Osc Fault Rec.** must be configured to in the **Functional Scope**. Apart from the option to store fault records via pickup of the protection function, the 7SJ80 also allows for initiating a measured value recording via the DIGSI operating program, the serial interface and binary input. For the latter, the information „>Trig.Wave.Cap.“ must have been allocated to a binary input. Triggering for the oscillographic recording then occurs, for instance, via the binary input when the protection object is energized.

Those that are externally triggered (that is, without a protective element pickup) are processed by the device as a normal oscillographic record. For each oscillographic record a fault record is created which is given its individual number to ensure that assignment can be made properly. However, these recordings are not displayed in the fault indication buffer, as they are not fault events.

Triggering Oscillographic Recording

To trigger test measurement recording with DIGSI, click on **Test** in the left part of the window. Double click the entry **Test Wave Form** in the list of the window.

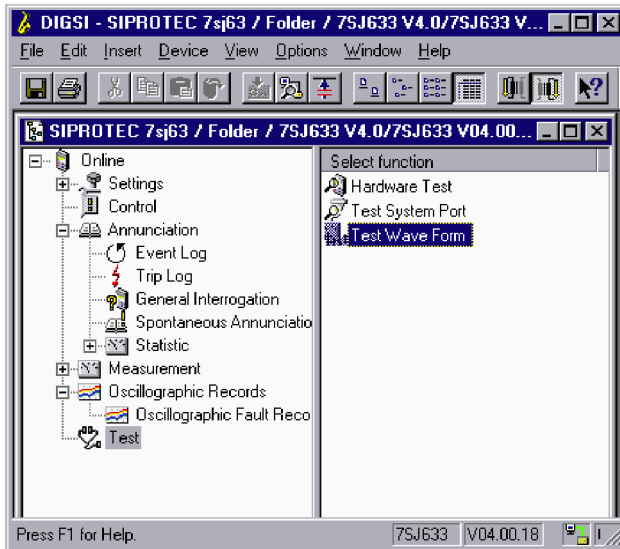

Figure 3-29 Screen for starting the test fault recording in DIGSI

Oscillographic recording is started immediately. During recording, a report is given in the left part of the status bar. Bar segments additionally indicate the progress of the procedure.

The SIGRA or the Comtrade Viewer program is required to view and analyse the oscillographic data.

3.4 Final Preparation of the Device

Firmly tighten all screws. Tighten all terminal screws, including those that are not used.



Caution!

Inadmissible Tightening Torques

Non-observance of the following measure can result in minor personal injury or property damage.

The tightening torques must not be exceeded as the threads and terminal chambers may otherwise be damaged!

The settings should be checked again, if they were changed during the tests. Check if all protection, control and auxiliary functions to be found with the configuration parameters are set correctly (Section 2.1.1, Functional Scope) and all desired functions are set to **ON**. Keep a copy of all setting values on a PC.

The device-internal clock should be checked and set, if necessary.

The annunciation buffers are deleted under **MAIN MENU** → **Annunciations** → **Set/Reset**, so that future information will only apply to actual events and states (see also SIPROTEC 4 System Description). The counters in the switching statistics should be reset to the values that were existing prior to the testing (see also SIPROTEC 4 System Description).

Reset the counter of the operational measured values (e.g. operation counter, if available) under **MAIN MENU** → **Measured Values** → **Reset** (also see SIPROTEC 4 System Description).

Press the Esc key (several times, if necessary) to return to the default display. The default display appears in the display box (e.g. the display of operational measured values).

Clear the LEDs on the front panel of the device by pressing the LED key so that they will show only real events and states in the future. In this context, also output relays probably memorized are reset. While pressing the LED key, the allocatable LEDs on the front panel light up, therefore this also serves as an LED test. LEDs indicating current conditions remain on, of course.

The green „RUN“ LED must light up, whereas the red „ERROR“ must not light up.

Close the protective switches. If test switches are available, then these must be in the operating position.

The device is now ready for operation.



This chapter provides the technical data of the device SIPROTEC 7SJ80 and its individual functions, including the limit values that may not be exceeded under any circumstances. The electrical and functional data for the maximum functional scope are followed by the mechanical specifications with dimensioned drawings.

4.1	General Device Data	402
4.2	Definite-time Overcurrent Protection	411
4.3	Inverse-time Overcurrent Protection	413
4.4	Directional Overcurrent Protection	424
4.5	Inrush Restraint	426
4.6	Dynamic Cold Load Pickup	427
4.7	1-phase Overcurrent Protection	428
4.8	Voltage Protection	429
4.9	Negative Sequence Protection (definite-time characteristic)	432
4.10	Negative Sequence Protection (inverse-time characteristics)	433
4.11	Frequency Protection	439
4.12	Undervoltage-controlled reactive power protection (27/Q)	442
4.13	Thermal Overload Protection	444
4.14	Ground Fault Detection (Sensitive/Insensitive)	446
4.15	Intermittent Ground Fault Protection	450
4.16	Directional intermittent ground fault protection	451
4.17	Automatic Reclosing System 79	452
4.18	Fault Locator	453
4.19	Breaker Failure Protection 50BF	454
4.20	Flexible Protection Functions	455
4.21	Synchrocheck 25	458
4.22	User-defined Functions (CFC)	460
4.23	Additional Functions	465
4.24	Switching Device Control	470
4.25	Dimensions	471

4.1 General Device Data

4.1.1 Analog Inputs

Current Inputs

Nominal Frequency	f_{Nom}	50 Hz or 60 Hz	(adjustable)
Operating range frequency (not dependent on the nominal frequency)		25 Hz to 70 Hz	
Nominal current	I_{Nom}	1 A or 5 A	
Ground current, sensitive	I_{Ns}	$\leq 1,6 \cdot I_{Nom}$ linear range ¹⁾	
Burden per phase and ground path			
- at $I_{Nom} = 1$ A		≤ 0.05 VA	
- at $I_{Nom} = 5$ A		≤ 0.3 VA	
- for sensitive ground fault detection at 1 A		≤ 0.05 VA	
- for sensitive ground fault detection at 5 A		≤ 0.3 VA	
Load capacity current path			
- thermal (rms)		500 A for 1 s 150 A for 10 s 20 A continuous	
- dynamic (peak value)		1250 A (half-cycle)	
Load capacity input for sensitive ground fault detection I_{Ns} ¹⁾			
- thermal (rms)		300 A for 1 s 100 A for 10 s 15 A continuous	
- dynamic (peak value)		750 A (half-cycle)	

¹⁾ only in models with input for sensitive ground fault detection (see ordering data in Appendix A.1)

Voltage Inputs

Nominal voltage		34 V – 225 V (adjustable) for connection of phase-to-ground voltages 34 V – 200 V (adjustable) for connection of phase-to-phase voltages
Measuring Range		0 V to 200 V
Burden	at 100 V	approx. 0.005 VA
Overload capacity in the voltage path		
– thermal (rms)		230 V continuous

4.1.2 Auxiliary voltage

Direct Voltage

Voltage supply via an integrated converter		
Nominal auxiliary DC voltage V_{Aux}	DC 24 V to 48 V	DC 60 V to 250 V
Permissible voltage ranges	DC 19 V to 60 V	DC 48 V to 300 V
Overvoltage category, IEC 60255-27	III	
AC ripple voltage peak to peak, IEC 60255-11	15 % of auxiliary voltage	

Power input	Quiescent	Energized
7SJ80	approx. 5 W	approx. 12 W
Bridging time for failure/short-circuit, IEC 60255-11	≥ 50 ms at $V \geq 110$ V	
	≥ 10 ms at $V < 110$ V	

Alternating Voltage

Voltage supply via an integrated converter		
Nominal auxiliary AC voltage V_H	AC 115 V	AC 230 V
Permissible voltage ranges	AC 92 V to 132 V	AC 184 V to 265 V
Overvoltage category, IEC 60255-27	III	

Power input (at 115 VAC / 230 VAC)	< 15 VA
Bridging time for failure/short-circuit	≥ 10 ms at $V = 115$ V/230 V

4.1.3 Binary Inputs and Outputs

Binary Inputs

Variant	Quantity	
7SJ801/803	3 (configurable)	
7SJ802/804	7 (configurable)	
7SJ807/808	11 (configurable)	
Nominal direct voltage range	24 V to 250 V	
Current input, energized (independent of the control voltage)	Approx. 0,4 mA	
Pickup time Response Time of the binary output after trigger signal via binary input	Approx. 3 ms approx. 9 ms	
Dropout time Response Time of the binary output after trigger signal via binary input	Approx. 4 ms approx. 5 ms	
Secured switching thresholds	(adjustable)	
for nominal voltages	24 to 125 VDC	V high > 19 VDC V low < 10 VDC
for nominal voltages	110 to 250 VDC	V high > 88 VDC V low < 44 VDC

for nominal voltages	220 to 250 VDC	V high > 176 VDC V low < 88 VDC
Maximum permissible voltage	300 VDC	
Input interference suppression	220 Vdc across 220nF at a recovery time between two switching operations ≥ 60 ms	

Output Relays

Signal/command Relay, Alarm Relay		
Quantity and data	depending on the order variant (allocatable)	
Order variant	NO contact	NO/NC selectable
7SJ801/803/807/808	3	2 (+ 1 life contact not allocatable)
7SJ802/804	6	2 (+ 1 life contact not allocatable)
Switching Capability MAKE	1000 W / 1000 VA	
Switching capability BREAK	40 W or 30 VA at L/R ≤ 40 ms	
Switching voltage AC and DC	250 V	
Admissible current per contact (continuous)	5 A	
Permissible current per contact (close and hold)	30 A for 1 s (NO contact)	
Interference suppression capacitor at the relay outputs 2.2 nF, 250 V, ceramic	Frequency	Impedance
	50 Hz	1,4 · 10 ⁶ Ω ± 20 %
	60 Hz	1,2 · 10 ⁶ Ω ± 20 %

4.1.4 Communication Interfaces

User Interface

Terminal	Front side, non-isolated, USB type B socket for connecting a personal computer Operation from DIGSI V4.82 via USB 2.0 full speed
Operation	With DIGSI
Transmission speed	up to 12 Mbit/s max.
Bridgeable distance	5 m

Port A

Ethernet electrical for DIGSI or SICAM I/O Unit 7XV5673	Operation	With DIGSI
	Terminal	Front case bottom, mounting location "A", RJ45 socket 100BaseT in acc. with IEEE802.3 LED yellow: 10/100 Mbit/s (on/off) LED green: connection/no connection (on/off)
	Test voltage	500 V; 50 Hz
	Transmission speed	10/100 Mbit/s
	Bridgeable distance	20 m (66 ft)

Port B

IEC 60870-5-103 single	Isolated interface for data transfer to a control center	
	RS232/RS485/FO depending on the order variant	
RS232	Terminal	Back case bottom, mounting location "B", 9-pin DSUB socket
	Test voltage	500 V; 50 Hz
	Transmission speed	min. 1,200 Bd; max. 115,000 Bd; factory setting 9,600 Bd
	Bridgeable distance	15 m
RS485	Terminal	Back case bottom, mounting location "B", 9-pin DSUB socket
	Test voltage	500 V; 50 Hz
	Transmission speed	min. 1,200 Bd; max. 115,000 Bd; factory setting 9,600 Bd
	Bridgeable distance	max. 1 km
Fiber optic cable (FO)	FO connector type	ST connector
	Terminal	Back case bottom, mounting location "B"
	Optical wavelength	$\lambda = 820 \text{ nm}$
	Laser Class 1 according to EN 60825-1/-2	When using glass fiber 50 μm /125 μm or glass fiber 62.5 μm /125 μm
	Permissible optical signal attenuation	max. 8 dB, with glass fiber 62.5 μm /125 μm
	Bridgeable distance	max. 1.5 km
	Character idle state	Configurable; factory setting „Light off“
IEC 60870-5-103 redundant RS485	Isolated interface for data transfer to a control center	
	Terminal	Back case bottom, mounting location "B", RJ45 socket
	Test voltage	500 V; 50 Hz
	Transmission speed	min. 2,400 Bd, max. 57,600 Bd; factory setting 19,200 Bd
	Bridgeable distance	max. 1 km
Profibus RS485 (DP)	Terminal	Back case bottom, mounting location "B", 9-pin DSUB socket
	Test voltage	500 V; 50 Hz
	Transmission speed	Up to 1.5 MBd
	Bridgeable distance	1 000 m (3 300 ft) at $\leq 93.75 \text{ kBd}$ 500 m (1 600 ft) at $\leq 187.5 \text{ kBd}$ 200 m (660 ft) at $\leq 1.5 \text{ MBd}$

Profibus FO (DP)	FO connector type	ST connector Double ring
	Terminal	Back case bottom, mounting location "B"
	Transmission speed	Up to 1.5 MBd
	Recommended:	> 500 kBd with normal casing
	Optical wavelength	$\lambda = 820 \text{ nm}$
	Laser Class 1 according to EN 60825-1/-2	When using glass fiber 50 μm 125 μm or glass fiber 62.5 μm /125 μm
	Permissible optical signal attenuation	max. 8 dB, with glass fiber 62.5/125 μm
	Bridgeable distance	max. 2 km
DNP3.0 /MODBUS RS485	Terminal	Back case bottom, mounting location "B", 9-pin DSUB socket
	Test voltage	500 V; 50 Hz
	Transmission speed	Up to 19,200 Bd
	Bridgeable distance	max. 1 km
	DNP3.0 /MODBUS FO	FO connector type
Terminal		Back case bottom, mounting location "B"
Transmission speed		Up to 19,200 Bd
Optical wavelength		$\lambda = 820 \text{ nm}$
Laser Class 1 according to EN 60825-1/-2		When using glass fiber 50 μm /125 μm or glass fiber 62.5 μm /125 μm
Permissible optical signal attenuation		max. 8 dB, with glass fiber 62.5 μm /125 μm
Bridgeable distance		max. 1.5 km
Ethernet electrical (EN 100) for DIGSI IEC61850 DNP3 TCP PROFINET or SICAM I/O unit 7XV5673	Terminal	Back case bottom, mounting location "B", 2 x RJ45 socket 100BaseT in acc. with IEEE802.3
	Test voltage (with regard to the socket)	500 V; 50 Hz
	Transmission speed	100 Mbit/s
	Bridgeable distance	21.87 yd
	Ethernet optical (EN 100) for DIGSI IEC61850 DNP3 TCP PROFINET or SICAM I/O unit 7XV5673	Terminal
Transmission speed		100 Mbit/s
Optical wavelength		1300 nm
Bridgeable distance		max. 2 km (1.24 mi)

4.1.5 Electrical Tests

Regulations

Standards:	IEC 60255 IEEE Std C37.90, see individual functions VDE 0435 for more standards see also individual functions
------------	--

Insulation Test

Standards:	IEC 60255-27 and IEC 60870-2-1
Voltage test (routine test) of all circuits except auxiliary voltage, binary inputs and communication ports	2.5 kV, 50 Hz
Voltage test (routine test) of auxiliary voltage and binary inputs	DC 3.5 kV
Voltage test (routine test) of isolated communication ports only (A and B)	500 V, 50 Hz
Impulse voltage test (type test) of all process circuits (except for communication ports) against the internal electronics	6 kV (peak value); 1.2 µs/50 µs; 0.5 J; 3 positive and 3 negative impulses at intervals of 1 s
Impulse voltage test (type test) of all process circuits against each other (except for communication ports) and against the PE terminal of class III	5 kV (peak value); 1.2 µs/50 µs; 0.5 J; 3 positive and 3 negative impulses at intervals of 1 s

EMC Tests for Immunity (Type Tests)

Standards:	IEC 60255-6 and -22, (product standards) IEC/EN 61000-6-2 VDE 0435 For more standards see also individual functions	
1 MHz test, Class III IEC 60255-22-1, IEC 61000-4-18, IEEE C37.90.1	2.5 kV (Peak); 1 MHz; $\tau = 15 \mu\text{s}$; 400 Surges per s; Test duration 2 s; $R_i = 200 \Omega$	
Electrostatic discharge, Class IV IEC 60255-22-2, IEC 61000-4-2	8 kV contact discharge; 15 kV air discharge, both polarities; 150 pF; $R_i = 330 \Omega$	
Radio frequency electromagnetic field, amplitude-modulated, Class III IEC 60255-22-3, IEC 61000-4-3	10 V/m; 80 MHz to 2.7 GHz; 80 % AM; 1 kHz	
Fast transient bursts, Class IV IEC 60255-22-4, IEC 61000-4-4, IEEE C37.90.1	4 kV; 5 ns/50 ns; 5 kHz; burst length = 15 ms; repetition rate 300 ms; both polarities; $R_i = 50 \Omega$; test duration 1 min	
High energy surge voltages (SURGE), Installation Class III IEC 60255-22-5, IEC 61000-4-5	Impulse: 1.2 µs/50 µs	
	Auxiliary voltage	common mode: 4 kV; 12 Ω ; 9 µF Diff. mode: 1 kV; 2 Ω ; 18 µF
	Measuring inputs, binary inputs and relay outputs	common mode: 4 kV; 42 Ω ; 0,5 µF Diff. mode: 1 kV; 42 Ω ; 0,5 µF
HF on lines, amplitude-modulated, Class III IEC 60255-22-6, IEC 61000-4-6	10 V; 150 kHz to 80 MHz; 80 % AM; 1 kHz	
Power system frequency magnetic field IEC 61000-4-8, Class IV;	30 A/m continuous; 300 A/m for 3 s;	

Radiated Electromagnetic Interference IEEE Std C37.900.2	20 V/m; 80 MHz to 1 GHz; 80 % AM; 1 kHz
Damped oscillations IEC 61000-4-18	2.5 kV (peak value); 100 kHz; 40 pulses per s; Test Duration 2 s; $R_i = 200 \Omega$

EMC Tests for Noise Emission (Type Test)

Standard:	IEC/EN 61000-6-4
Radio noise voltage to lines, only auxiliary voltage IEC-CISPR 11	150 kHz to 30 MHz Limit Class A
Interference field strength IEC-CISPR 11	30 MHz to 1000 MHz Limit Class A
Harmonic currents on the network lead at AC 230 V IEC 61000-3-2	Device is to be assigned Class D (applies only to devices with > 50 VA power consumption)
Voltage fluctuations and flicker on the network lead at AC 230 V IEC 61000-3-3	Limit values are kept

4.1.6 Mechanical Tests

Vibration and Shock Stress during Steady-State Operation

Standards:	IEC 60255-21 and IEC 60068
Oscillation IEC 60255-21-1, Class II; IEC 60068-2-6	Sinusoidal 10 Hz to 60 Hz: ± 0.075 mm amplitude; 60 Hz to 150 Hz: 1g acceleration frequency sweep rate 1 octave/min 20 cycles in 3 orthogonal axes.
Shock IEC 60255-21-2, Class I; IEC 60068-2-27	Semi-sinusoidal 5 g acceleration, duration 11 ms, each 3 shocks in both directions of the 3 axes
Seismic Vibration IEC 60255-21-3, Class II; IEC 60068-3-3	Sinusoidal 1 Hz to 8 Hz: ± 7.5 mm amplitude (horizontal axis) 1 Hz to 8 Hz: ± 3.5 mm amplitude (vertical axis) 8 Hz to 35 Hz: 2 g acceleration (horizontal axis) 8 Hz to 35 Hz: 1 g acceleration (vertical axis) Frequency sweep 1 octave/min 1 cycle in 3 orthogonal axes

Vibration and Shock Stress during Transport

Standards:	IEC 60255-21 and IEC 60068
Oscillation IEC 60255-21-1, Class 2; IEC 60068-2-6	Sinusoidal 5 Hz to 8 Hz: ± 7.5 mm amplitude; 8 Hz to 150 Hz: 2 g acceleration Frequency sweep 1 octave/min 20 cycles in 3 orthogonal axes
Shock IEC 60255-21-2, Class 1; IEC 60068-2-27	Semi-sinusoidal 15 g acceleration, duration 11 ms, each 3 shocks (in both directions of the 3 axes)
Continuous Shock IEC 60255-21-2, Class 1; IEC 60068-2-29	Semi-sinusoidal 10 g acceleration, duration 16 ms, each 1000 shocks (in both directions of the 3 axes)

4.1.7 Climatic Stress Tests

Temperatures

Standards:	IEC 60255-6
Type test (in acc. with IEC 60068-2-1 and -2, Test Bd for 16 h)	-25 °C to +85 °C or -13 °F to +185 °F
Permissible temporary operating temperature (tested for 96 h)	-20 °C to +70 °C or -4 °F to +158 °F (clearness of the display may be impaired from +55 °C or +131 °F)
Recommended for permanent operation (in acc. with IEC 60255-6)	-5 °C to +55 °C or +23 °F to +131 °F
Limit temperatures for storage	-25 °C to +55 °C or -13 °F to +131 °F
Limit temperatures for transport	-25 °C to +70 °C or -13 °F to +158 °F
Storage and transport with factory packaging	

Humidity

Permissible humidity	Mean value per year \leq 75 % relative humidity; on 56 days of the year up to 93 % relative humidity; condensation must be avoided!
Siemens recommends that all devices be installed such that they are not exposed to direct sunlight, nor subject to large fluctuations in temperature that may cause condensation to occur.	

4.1.8 Service Conditions

<p>The protective device is designed for use in an industrial environment and an electrical utility environment. Proper installation procedures should be followed to ensure electromagnetic compatibility (EMC).</p> <p>In addition, the following is recommended:</p> <ul style="list-style-type: none"> • All contacts and relays that operate in the same cubicle, cabinet, or relay panel as the numerical protective device should, as a rule, be equipped with suitable surge suppression components. • For substations with operating voltages of 100 kV and above, all external cables should be shielded with a conductive shield grounded at both ends. For substations with lower operating voltages, no special measures are normally required. • Do not withdraw or insert individual modules or boards while the protective device is energized. In withdrawn condition, some components are electrostatically endangered; during handling the ESD standards (for Electrostatic Sensitive Developments) must be observed. They are not endangered when inserted into the case.

4.1.9 Constructive Design

Case	7XP20
Dimensions	see dimensional drawings, Section 4.25

Device	Case	Size	Weight
7SJ80**-*B	for panel surface mounting	1/6	4.5 kg (9.9 lb)
7SJ80**-*E	for panel flush mounting	1/6	4 kg (8.8 lb)

Protection type acc. to IEC 60529	
For equipment in the surface-mounting case	IP 50
For equipment in flush mounting case	Front IP 51 Rear IP 50
for operator protection	IP 2x for current terminal IP 1x for voltage terminal
Degree of pollution, IEC 60255-27	2

4.1.10 UL certification conditions

The data in the following table apply to the device variants 7SJ801, 7SJ802, 7SJ803 and 7SJ804. UL certification for 7SJ807 and 7SJ808 is under way.

Output Relays	24 VDC	5 A General Purpose
	48 VDC	0.8 A General Purpose
	240 VDC	0.1 A General Purpose
	240 VAC	5 A General Purpose
	120 VAC	1/3 hp
	250 VAC	1/2 hp
	B300, R300	
Voltage Inputs	Input voltage range	300 V
Battery	<p>Servicing of the circuitry involving the batteries and replacement of the lithium batteries shall be done by a trained technician. Replace Battery with VARTA or Panasonic Cat. Nos. CR 1/2 AA or BR 1/2 AA only. Use of another Battery may present a risk of fire or explosion. See manual for safety instructions. Caution: The battery used in this device may present a fire or chemical burn hazard if mistreated. Do not recharge, disassemble, heat above 100 °C (212 °F) or incinerate. Dispose of used battery promptly. Keep away from children.</p>	
Climatic Stress Tests	Surrounding air temperature	tsurr: max. 70 °C (158 °F), normal operation
Design	<p>Field Wires of Control Circuits shall be separated from other circuits with respect to the end use requirements! Type 1 if mounted into a door or front cover of an enclosure.</p>	

4.2 Definite-time Overcurrent Protection

Operating Modes

Three-phase	Standard
Two-phase	Phases A and C

Measuring Method

All elements	First harmonic, r.m.s. value (true RMS)
51Ns-3	Additional instantaneous values

Setting Ranges / Increments

Pickup current 50-1, 50-2 (phases)	for $I_{Nom} = 1 \text{ A}$	0.10 A to 35.00 A or ∞ (disabled)	Increments 0.01 A
	for $I_{Nom} = 5 \text{ A}$	0.50 A to 175.00 A or ∞ (disabled)	
Pickup current 50-3 (phases)	for $I_{Nom} = 1 \text{ A}$	1.0 A to 35.00 A or ∞ (disabled)	
	for $I_{Nom} = 5 \text{ A}$	5.0 A to 175.00 A or ∞ (disabled)	
Pickup Current 50N-1, 50N-2 (ground)	for $I_{Nom} = 1 \text{ A}$	0.05 A to 35.00 A or ∞ (disabled)	Increments 0.01 A
	for $I_{Nom} = 5 \text{ A}$	0.25 A to 175.00 A or ∞ (disabled)	
Pickup Current 50N-3 (ground)	for $I_{Nom} = 1 \text{ A}$	0.25 A to 35.00 A or ∞ (disabled)	
	for $I_{Nom} = 5 \text{ A}$	1.25 A to 175.00 A or ∞ (disabled)	
Time delays T		0.00 s to 60.00 s or ∞ (disabled)	Increments 0.01 s
Dropout time delays 50 T DROP-OUT, 50N T DROP-OUT		0.00 s to 60.00 s	Increments 0.01 s

Times

Pickup times (without inrush restraint, with restraint + 1 period)	
First harmonic, rms value - for 2 x setting value - for 10 x setting value	approx. 30 ms Approx. 20 ms
Instantaneous value - for 2 x setting value - for 10 x setting value	approx. 16 ms approx. 16 ms
Dropout Times First harmonic, rms value Instantaneous value	approx. 30 ms approx. 40 ms

Dropout Ratio

Dropout ratio for - first harmonic, rms value - instantaneous value	approx. 0,95 for $I/I_{Nom} \geq 0.3$ approx. 0,90 for $I/I_{Nom} \geq 0.3$
---	--

Tolerances

Pickup times	3 % of setting value or 15 mA at $I_{Nom} = 1 \text{ A}$ or 75 mA at $I_{Nom} = 5 \text{ A}$
Time delays T	1 % or 10 ms

Influencing Variables for Pickup and Dropout

Auxiliary DC voltage in range $0.8 \leq V_{Aux}/V_{AuxNom} \leq 1.15$	1 %
Temperature in range $-5 \text{ °C (41 °F)} \leq \Theta_{amb} \leq 55 \text{ °C (131 °F)}$	0.5 %/10 K
Frequency in the range of 25 Hz – 70 Hz	
Frequency in the range of $0.95 \leq f/f_{Nom} \leq 1.05$ ($f_{Nom} = 50 \text{ Hz or } 60 \text{ Hz}$)	1 %
Frequency outside range $0.95 \leq f/f_{Nom} \leq 1.05$	Increased tolerances
Harmonics - up to 10 % 3rd harmonic - up to 10 % 5th harmonic at instantaneous value of 50-3/50N-3 elements	1 % 1 % Increased tolerances
Transient overreaction for $\tau > 100 \text{ ms}$ (with full displacement)	<5 %

4.3 Inverse-time Overcurrent Protection

Modes of Operation

Three-phase	Standard
Two-phase	Phases A and C
voltage-independent, voltage-controlled, voltage-dependent	

Measuring Technique

All elements	First harmonic, rms value (true rms)
--------------	--------------------------------------

Setting Ranges / Increments

Pickup currents 51 (phases)	for $I_{Nom} = 1\text{ A}$	0.10 A to 4.00 A	Increments 0.01 A
	for $I_{Nom} = 5\text{ A}$	0.50 A to 20.00 A	
Pickup currents 51N (ground)	for $I_{Nom} = 1\text{ A}$	0.05 A to 4.00 A	Increments 0.01 A
	for $I_{Nom} = 5\text{ A}$	0.25 A to 20.00 A	
Time multiplier T for 51, 51N for IEC characteristics		0.05 s to 3.20 s or ∞ (disabled)	Increments 0.01 s
Time multiplier T for 51, 51N for ANSI characteristics		0.50 s to 15.00 s or ∞ (disabled)	Increments 0.01 s
Undervoltage threshold 51V V< for release of 51		10.0 V to 125.0 V	Increments 0.1 V

Trip Time Curves acc. to IEC

Acc. to IEC 60255-3 or BS 142, Section 3.5.2 (see also Figures 4-1 and 4-2)	
INVERSE (Type A)	$t = \frac{0.14}{(I/I_p)^{0.02} - 1} \cdot T_p \quad [s]$
VERY INVERSE (Type B)	$t = \frac{13.5}{(I/I_p)^1 - 1} \cdot T_p \quad [s]$
EXTREMELY INV. (Type C)	$t = \frac{80}{(I/I_p)^2 - 1} \cdot T_p \quad [s]$
LONG INVERSE (Type B)	$t = \frac{120}{(I/I_p)^1 - 1} \cdot T_p \quad [s]$
Where: t Trip time in seconds T_p Setting Value of the Time Multiplier I Fault Current I_p Setting Value of the Pickup Current	
The tripping times for $I/I_p \geq 20$ are identical with those for $I/I_p = 20$	
For zero sequence current, read $3I_{0p}$ instead of I_p and $T_{3I_{0p}}$ instead of T_p ; for ground fault, read I_{Ep} instead of I_p and T_{IEp} instead of T_p	
Pickup threshold	approx. $1.10 \cdot I_p$

Dropout Time Characteristics with Disk Emulation acc. to IEC

Acc. to IEC 60255-3 or BS 142, Section 3.5.2 (see also Figures 4-1 and 4-2)	
INVERSE (Type A)	$t_{Reset} = \frac{9.7}{1 - (I/I_p)^2} \cdot T_p \quad [s]$
VERY INV. (Type B)	$t_{Reset} = \frac{43.2}{1 - (I/I_p)^2} \cdot T_p \quad [s]$
EXTREMELY INV. (Type C)	$t_{Reset} = \frac{58.2}{1 - (I/I_p)^2} \cdot T_p \quad [s]$
LONG INVERSE (Type B)	$t_{Reset} = \frac{80}{1 - (I/I_p)^2} \cdot T_p \quad [s]$
Where:	
t_{Reset}	Reset Time
T_p	Setting Value of the Time Multiplier
I	Fault Current
I_p	Setting Value of the Pickup Current
The dropout time curves apply to $(I/I_p) \leq 0.90$	
For zero sequence current, read $3I_{0p}$ instead of I_p and $T_{3I_{0p}}$ instead of T_p ; for ground fault, read I_{Ep} instead of I_p and T_{IEp} instead of T_p	

Dropout Setting

IEC without Disk Emulation	approx. $1.05 \cdot$ setting value I_p for $I_p/I_N \geq 0.3$, this corresponds to approx. $0.95 \cdot$ pickup value
IEC with Disk Emulation	approx. $0.90 \cdot I_p$ setting value

Tolerances

Pickup/dropout thresholds I_p, I_{Ep}	3 % of setting value or 15 mA for $I_{Nom} = 1$ A, or 75 mA for $I_{Nom} = 5$ A
Trip time for $2 \leq I/I_p \leq 20$	5 % of reference (calculated) value +2 % current tolerance, or 30 ms
Dropout time for $I/I_p \leq 0.90$	5 % of reference (calculated) value +2 % current tolerance, or 30 ms

Influencing Variables for Pickup and Dropout

Power supply direct voltage in range $0.8 \leq V_{Aux}/V_{AuxNom} \leq 1.15$	1 %
Temperature in Range $23.00 \text{ °F } (-5 \text{ °C}) \leq \Theta_{amb} \leq 131.00 \text{ °F } (55 \text{ °C})$	0.5 %/10 K
Frequency in range of 25 Hz – 70 Hz	
Frequency in range of $0.95 \leq f/f_{Nom} \leq 1.05$ ($f_{Nom} = 50$ Hz or 60 Hz)	1 %
Frequency in Range $0.95 \leq f/f_{Nom} \leq 1.05$	Increased Tolerances
Harmonics	
- up to 10 % 3rd harmonic	1 %
- up to 10 % 5th harmonic	1 %
Transient overreaction during first harmonic measuring technique for $\tau > 100$ ms (with full displacement)	<5 %

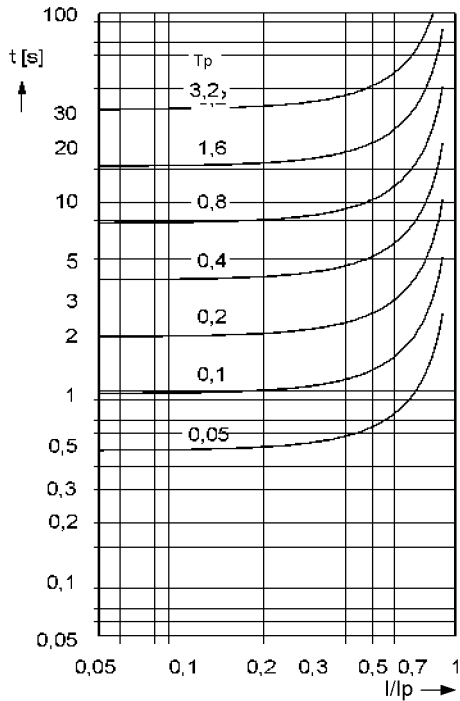

Dropout normal inverse: $t = \frac{9.7}{1 - (I/I_p)^2} \cdot T_p$ [s]
Type A

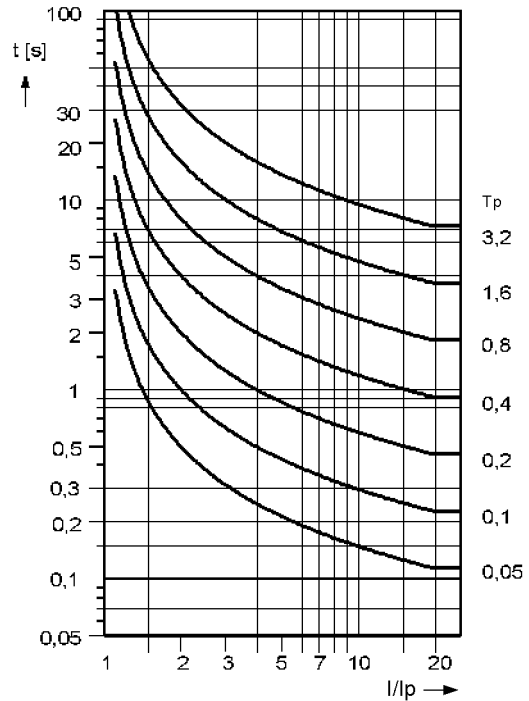

Normal Inverse: $t = \frac{0.14}{(I/I_p)^{0.02} - 1} \cdot T_p$ [s]
Type A

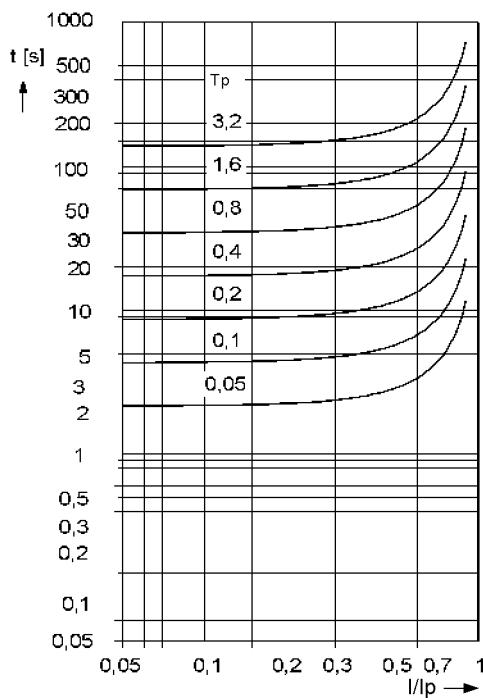

Reset Very Inverse: $t = \frac{43.2}{1 - (I/I_p)^2} \cdot T_p$ [s]
Type B

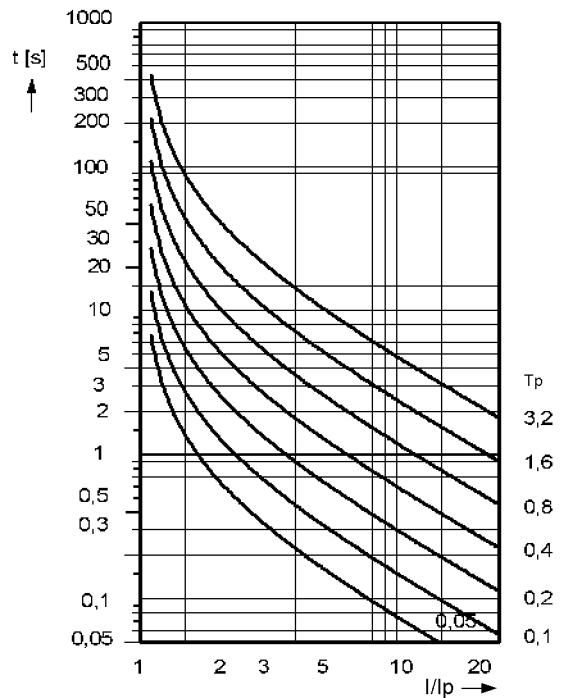

VERY INVERSE: $t = \frac{13.5}{(I/I_p)^1 - 1} \cdot T_p$ [s]
Type B

Figure 4-1 Dropout time and trip time curves of the inverse time overcurrent protection, acc. to IEC

4.3 Inverse-time Overcurrent Protection

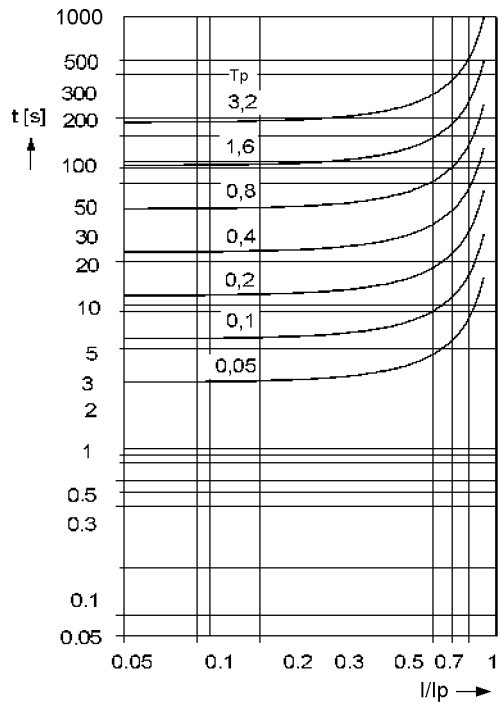

**Reset Extremely Inverse:
Type C**
$$t = \frac{58.2}{1 - (I/I_p)^2} \cdot T_p \text{ [s]}$$

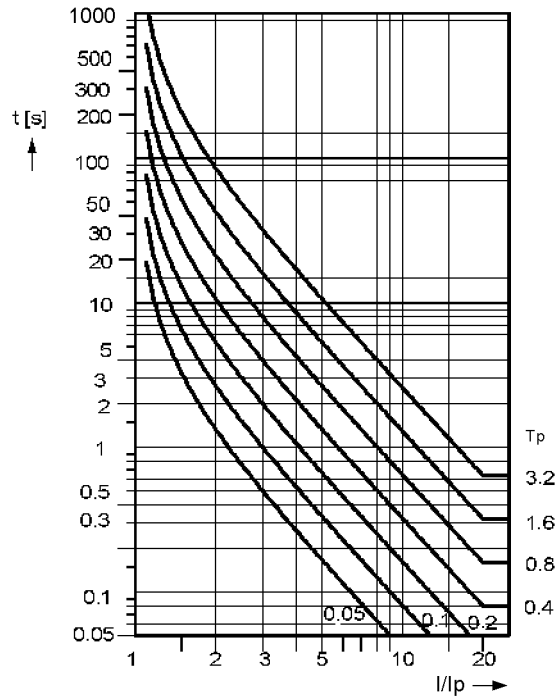

**Extremely Inverse:
Type C**
$$t = \frac{80}{(I/I_p)^2 - 1} \cdot T_p \text{ [s]}$$

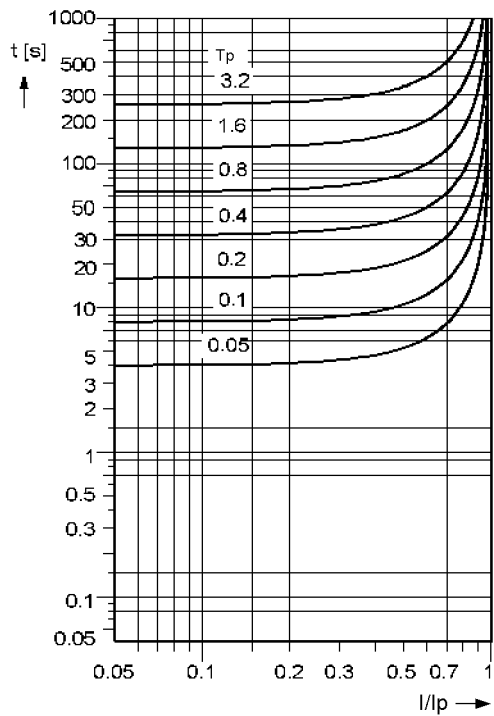

**Reset long inverse:
Type B**
$$t = \frac{80}{1 - (I/I_p)^2} \cdot T_p \text{ [s]}$$

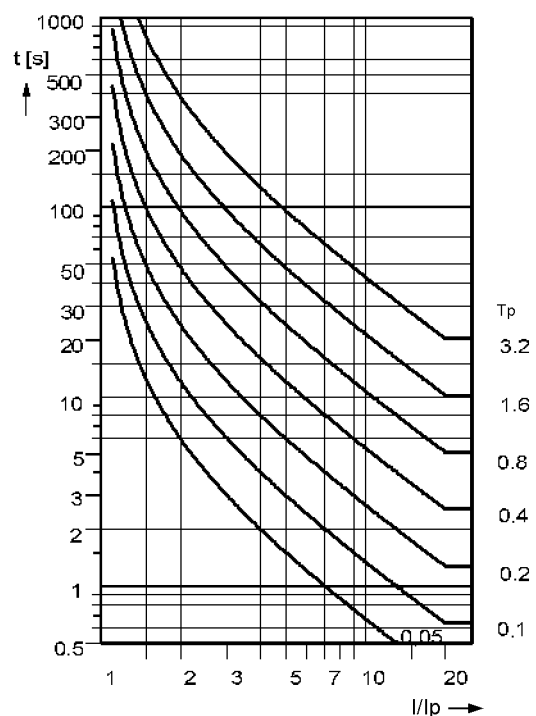

**Long time Inverse:
Type B**
$$t = \frac{120}{(I/I_p)^1 - 1} \cdot T_p \text{ [s]}$$

Figure 4-2 Dropout time and trip time curves of the inverse time overcurrent protection, acc. to IEC

Trip Time Curves acc. to ANSI

Acc. to ANSI/IEEE (see also Figures 4-3 to 4-6)	
INVERSE	$t = \left(\frac{8.9341}{(I/I_p)^{2.0938} - 1} + 0.17966 \right) \cdot D \quad [s]$
SHORT INVERSE	$t = \left(\frac{0.2663}{(I/I_p)^{1.2969} - 1} + 0.03393 \right) \cdot D \quad [s]$
LONG INVERSE	$t = \left(\frac{5.6143}{(I/I_p) - 1} + 2.18592 \right) \cdot D \quad [s]$
MODERATELY INV.	$t = \left(\frac{0.0103}{(I/I_p)^{0.02} - 1} + 0.0228 \right) \cdot D \quad [s]$
VERY INVERSE	$t = \left(\frac{3.922}{(I/I_p)^2 - 1} + 0.0982 \right) \cdot D \quad [s]$
EXTREMELY INV.	$t = \left(\frac{5.64}{(I/I_p)^2 - 1} + 0.02434 \right) \cdot D \quad [s]$
DEFINITE INV.	$t = \left(\frac{0.4797}{(I/I_p)^{1.5625} - 1} + 0.21359 \right) \cdot D \quad [s]$
Where: t Trip Time D Setting Value of the Time Multiplier I Fault Current I _p Setting Value of the Pickup Current	
The tripping times for I/I _p ≥ 20 are identical with those for I/I _p = 20.	
For zero sequence current read 3I _{0p} instead of I _p and T _{3I_{0p}} instead of T _p ; for ground fault read I _{Ep} instead of I _p and T _{I_{Ep}} instead of T _p	
Pickup Threshold	approx. 1.10 · I _p

Dropout Time Characteristics with Disk Emulation acc. to ANSI/IEEE

Acc. to ANSI/IEEE (see also Figures 4-3 to 4-6)	
INVERSE	$t_{Reset} = \left(\frac{8.8}{1 - (I/I_p)^{2.0938}} \right) \cdot D \quad [s]$
SHORT INVERSE	$t_{Reset} = \left(\frac{0.831}{1 - (I/I_p)^{1.2969}} \right) \cdot D \quad [s]$
LONG INVERSE	$t_{Reset} = \left(\frac{12.9}{1 - (I/I_p)^1} \right) \cdot D \quad [s]$
MODERATELY INV.	$t_{Reset} = \left(\frac{0.97}{1 - (I/I_p)^2} \right) \cdot D \quad [s]$
VERY INVERSE	$t_{Reset} = \left(\frac{4.32}{1 - (I/I_p)^2} \right) \cdot D \quad [s]$
EXTREMELY INV.	$t_{Reset} = \left(\frac{5.82}{1 - (I/I_p)^2} \right) \cdot D \quad [s]$
DEFINITE INV.	$t_{Reset} = \left(\frac{1.03940}{1 - (I/I_p)^{1.5625}} \right) \cdot D \quad [s]$
Where:	
	t_{Reset} Reset time
	D Setting value of the multiplier
	I Fault Current
	I_p Setting value of the pickup current
for $0.5 < (I/I_p) \leq 0.90$	
The dropout time curves apply to $(I/I_p) \leq 0.90$	
For zero sequence current read $3I_{0p}$ instead of I_p and $T_{3I_{0p}}$ instead of T_p ; for ground fault read I_{Ep} instead of I_p and T_{IEp} instead of T_p	

Dropout Setting

ANSI without Disk Emulation	approx. $1.05 \cdot$ setting value I_p for $I_p/I_N \geq 0.3$; this corresponds to approx. $0.95 \cdot$ pickup value
ANSI with Disk Emulation	approx. $0.90 \cdot I_p$ setting value

Tolerances

Pickup and Dropout Thresholds I_p , I_{Np}	3 % of setting value or 15 mA for $I_{Nom} = 1$ A or 75 mA for $I_{Nom} = 5$ A
Trip Time for $2 \leq I/I_p \leq 20$	5 % of reference (calculated) value +2 % current tolerance, or 30 ms
Dropout Time for $I/I_p \leq 0,90$	5 % of reference (calculated) value +2 % current tolerance, or 30 ms

Influencing Variables for Pickup and Dropout

Power supply direct voltage in range $0.8 \leq V_{Aux}/V_{AuxNom} \leq 1.15$	1 %
Temperature in range $23.00 \text{ °F } (-5 \text{ °C}) \leq \Theta_{amb} \leq 131.00 \text{ °F } (55 \text{ °C})$	0.5 %/10 K
Frequency in range of 25 Hz – 70 Hz	
Frequency in range of $0.95 \leq f/f_{Nom} \leq 1.05$ ($f_{Nom} = 50 \text{ Hz or } 60 \text{ Hz}$)	1 %
Frequency in range $0.95 \leq f/f_{Nom} \leq 1.05$	Increased Tolerances
Harmonics - up to 10 % 3rd harmonic - up to 10 % 5th harmonic	1% 1%
Transient overreaction during first harmonic measuring technique for $\tau > 100 \text{ ms}$ (with full displacement)	<5 %

4.3 Inverse-time Overcurrent Protection

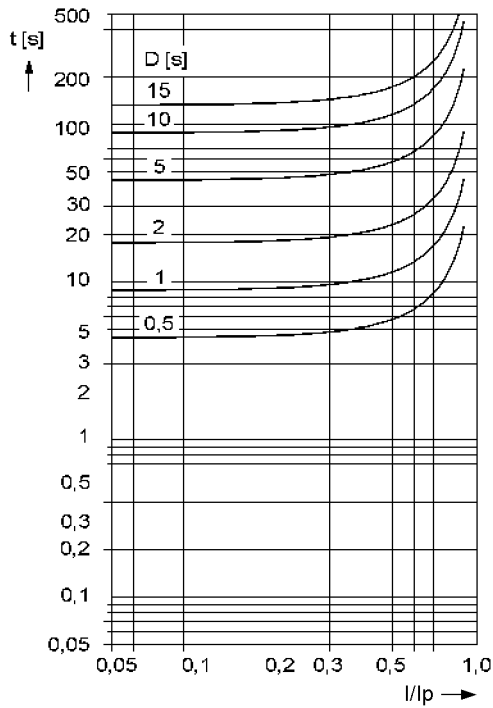

RESET INVERSE
$$t = \frac{8.8}{1 - (I/I_p)^{2.0938}} \cdot D \text{ [s]}$$

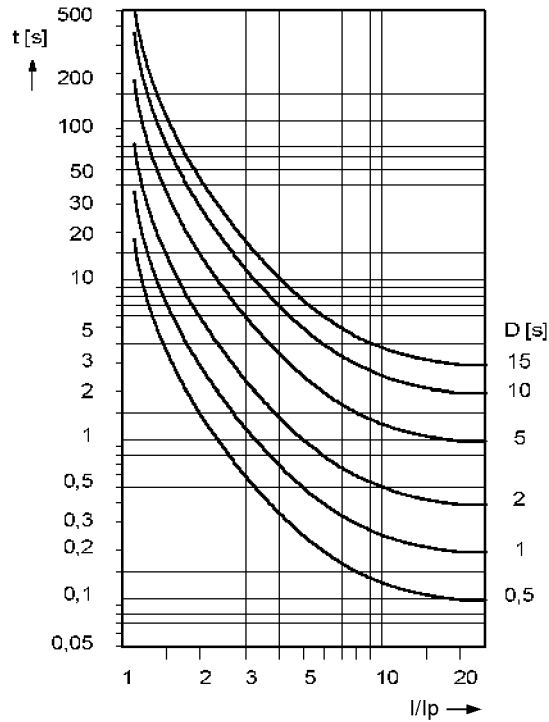

INVERSE
$$t = \left(\frac{8.9341}{(I/I_p)^{2.0938} - 1} + 0.17966 \right) \cdot D \text{ [s]}$$

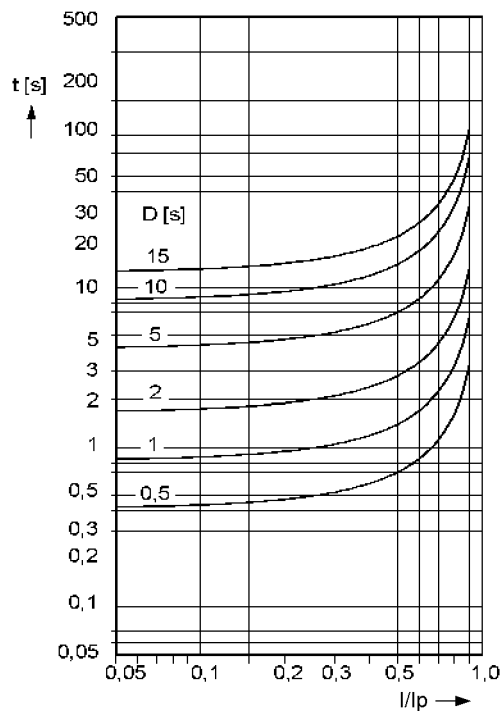

RESET SHORT INVERSE
$$t = \frac{0.831}{1 - (I/I_p)^{1.2969}} \cdot D \text{ [s]}$$

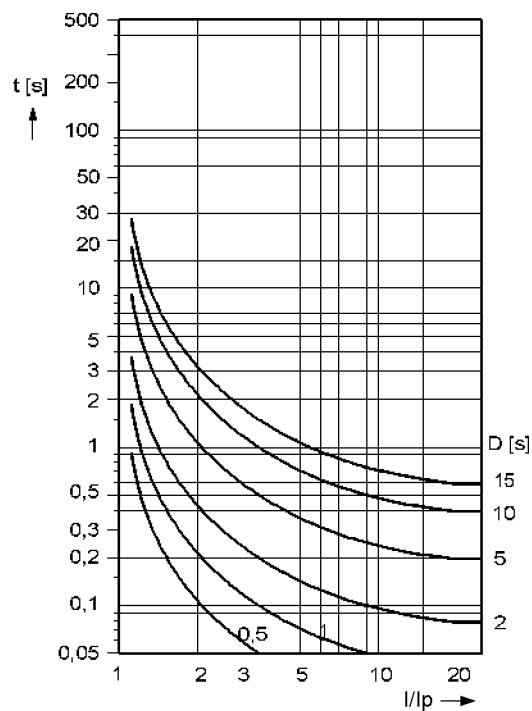

SHORT INVERSE
$$t = \left(\frac{0.2663}{(I/I_p)^{1.2969} - 1} + 0.03393 \right) \cdot D \text{ [s]}$$

Figure 4-3 Dropout time and trip time curves of the inverse time overcurrent protection, acc. to ANSI/IEEE

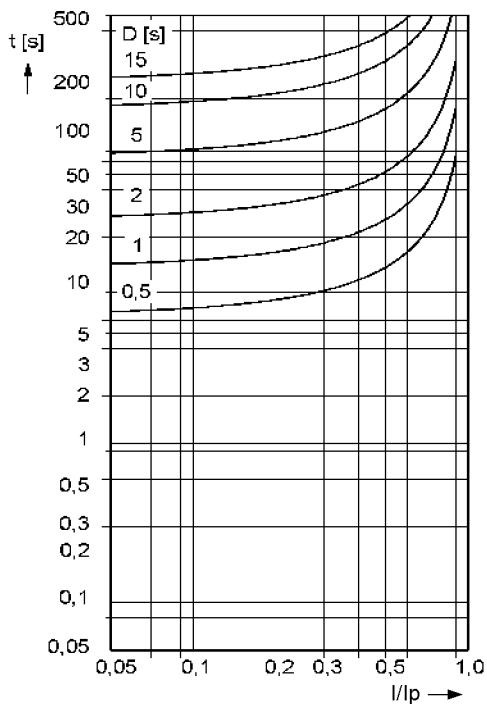

RESET LONG INVERSE

$$t = \left(\frac{12.9}{1 - (I/I_p)^1} \right) \cdot D \text{ [s]}$$

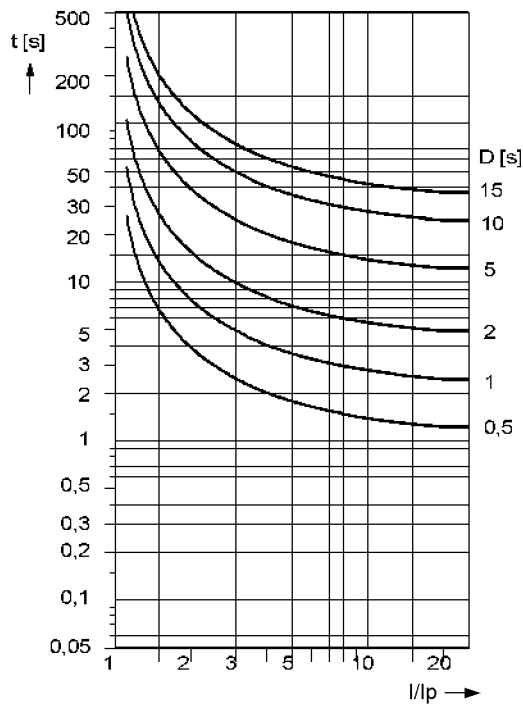

LONG INVERSE

$$t = \left(\frac{5.6143}{(I/I_p)^1 - 1} + 2.18592 \right) \cdot D \text{ [s]}$$

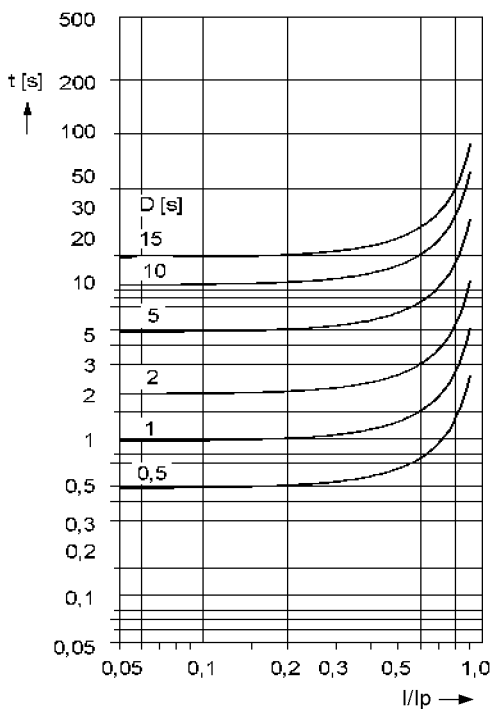

RESET MODERATELY INVERSE

$$t = \left(\frac{0.97}{1 - (I/I_p)^2} \right) \cdot D \text{ [s]}$$

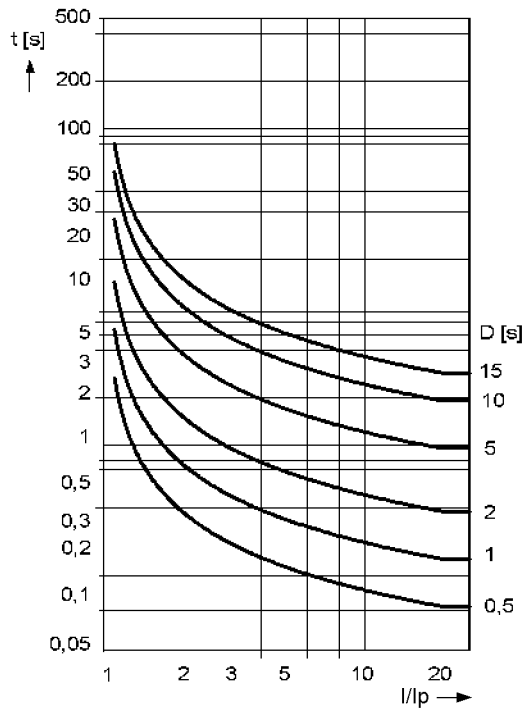

MODERATELY INVERSE

$$t = \left(\frac{0.0103}{(I/I_p)^{0.02} - 1} + 0.0228 \right) \cdot D \text{ [s]}$$

Figure 4-4 Dropout time and trip time curves of the inverse time overcurrent protection, acc. to ANSI/IEEE

4.3 Inverse-time Overcurrent Protection

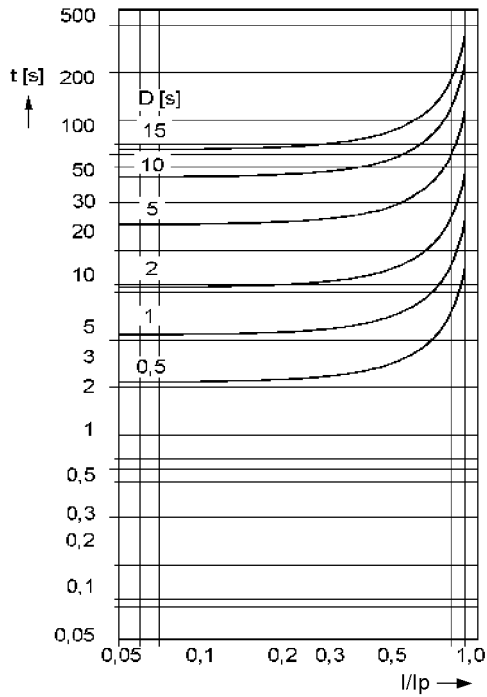

RESET VERY INVERSE $t = \left(\frac{4.32}{1 - (I/I_p)^2} \right) \cdot D \text{ [s]}$

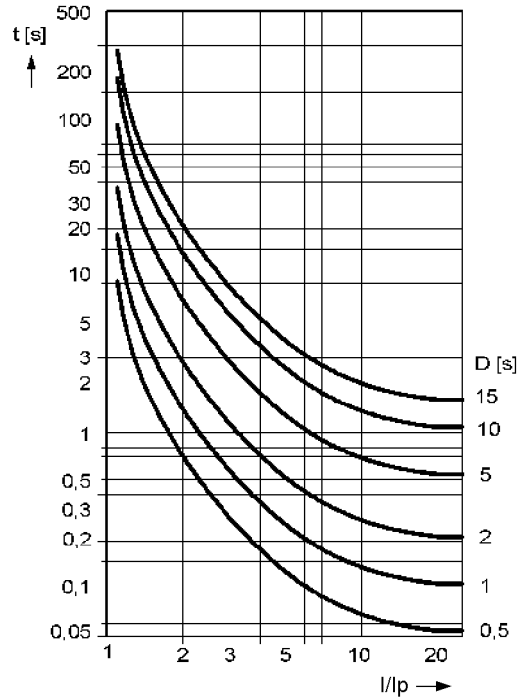

VERY INVERSE: $t = \left(\frac{3.922}{(I/I_p)^2 - 1} + 0.0982 \right) \cdot D \text{ [s]}$

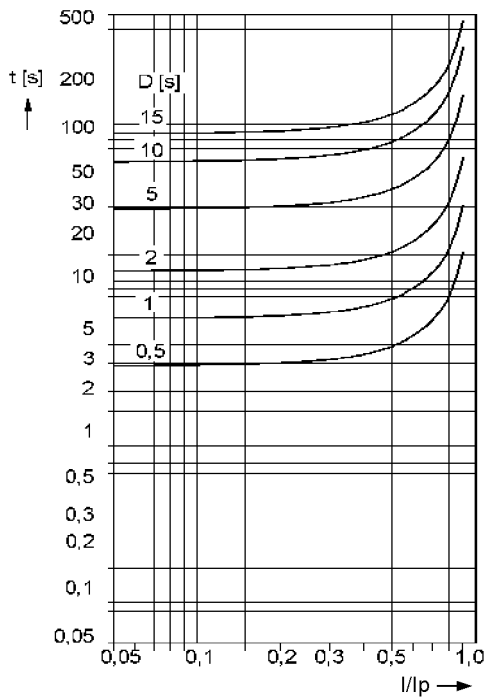

RESET EXTREMELY INVERSE $t = \left(\frac{5.82}{1 - (I/I_p)^2} \right) \cdot D \text{ [s]}$

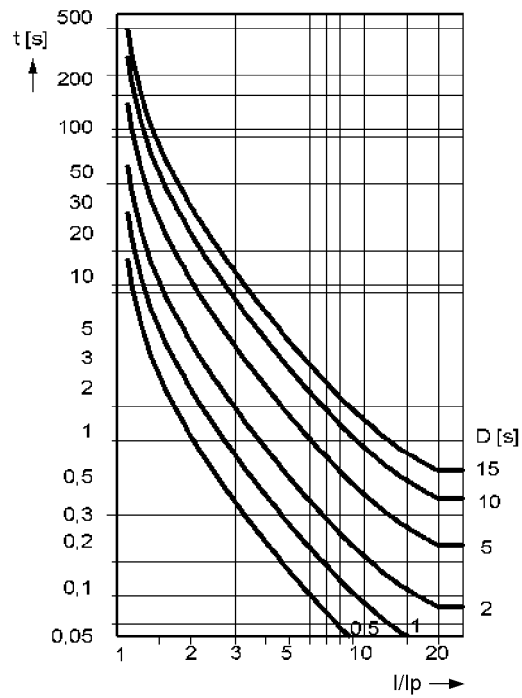

EXTREMELY INVERSE $t = \left(\frac{5.64}{(I/I_p)^2 - 1} + 0.02434 \right) \cdot D \text{ [s]}$

Figure 4-5 Dropout time and trip time curves of the inverse time overcurrent protection, acc. to ANSI/IEEE

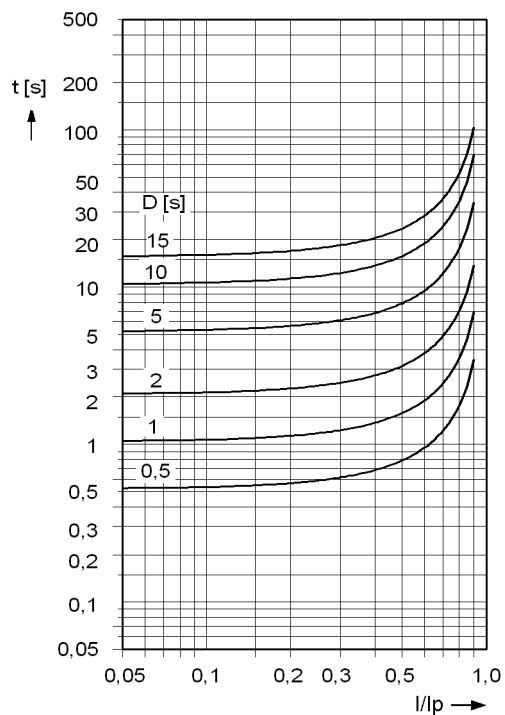

RESET DEFINITE INVERSE

$$t = \left(\frac{1.0394}{1 - (I/I_p)^{1.5625}} \right) \cdot D \text{ [s]}$$

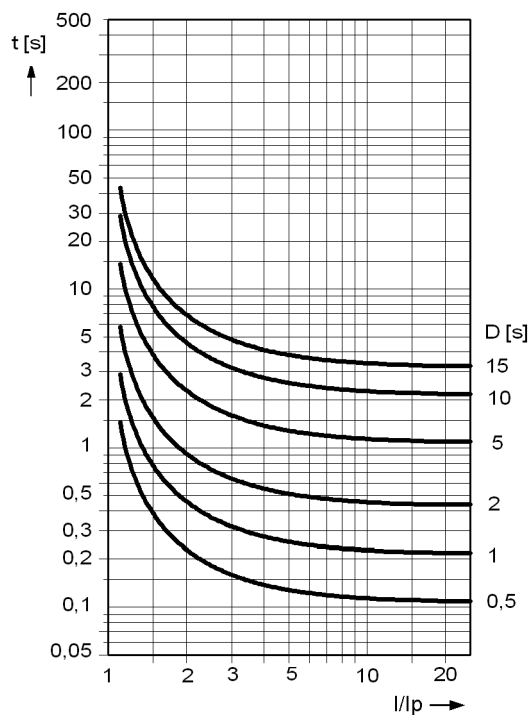

DEFINITE INVERSE

$$t = \left(\frac{0.4797}{(I/I_p)^{1.5625} - 1} + 0.21359 \right) \cdot D \text{ [s]}$$

Note:
For earth fault read IEP instead of Ip and DIEp instead of Dip.

Figure 4-6 Dropout time and trip time curve of the inverse time overcurrent protection, acc. to ANSI/IEEE

4.4 Directional Overcurrent Protection

Time Overcurrent Elements

The same specifications and characteristics apply as for non-directional time overcurrent protection (see previous Sections).

Determination of Direction

Moreover, the following data apply to direction determination:

For Phase Faults

Type	With cross-polarized voltages; with voltage memory (memory depth 2 seconds) for measuring voltages which are too small
Forward range	$V_{ref,rot} \pm 86^\circ$
Rotation of the reference voltage $V_{ref,rot}$	-180° to +180° Increments 1°
Dropout difference	3°
Directional sensitivity	Unlimited for single- and two-phase faults For three-phase faults, dynamically unlimited, steady-state approx. 7V phase-to-phase

For Ground Faults

Polarization	with zero sequence quantities $3V_0, 3I_0$
Forward range	$V_{ref,rot} \pm 86^\circ$
Rotation of the reference voltage $V_{ref,rot}$	-180° to +180° Increments 1°
Dropout difference	3°
Directional sensitivity	$V_N \approx 2.5$ V displacement voltage, measured $3V_0 \approx 5$ V displacement voltage, calculated

Polarization	with negative sequence quantities $3V_2, 3I_2$
Forward range	$V_{ref,rot} \pm 86^\circ$
Rotation of the reference voltage $V_{ref,rot}$	-180° to +180° Increments 1°
Dropout difference	3°
Directional sensitivity	$3V_2 \approx 5$ V negative sequence voltage $3I_2 \approx 45$ mA negative sequence current with $I_{Nom} = 1$ A $3I_2 \approx 225$ mA negative sequence current with $I_{Nom} = 5$ A

Times

Pickup times (without inrush restraint, with restraint + 1 period)	
50-1, 50-2, 50-3, 50N-1, 50N-2, 50N-3 - for 2 x setting value - for 10 x setting value	approx. 45 ms approx. 40 ms
Dropout Times 50-1, 50-2, 50-3, 50N-1, 50N-2, 50N-3	approx. 40 ms

Tolerances

Angle faults for phase and ground faults	$\pm 1^\circ$ electrical
--	--------------------------

Influencing Variables

Frequency Influence – With no memory voltage	approx 1° in range 25 Hz to 50 Hz
---	--

4.5 Inrush Restraint

Controlled Functions

Overcurrent elements	50-1, 50N-1, 51, 51N, 67-1, 67N-1
----------------------	-----------------------------------

Setting Ranges / Increments

Stabilization factor I_{2f}/I	10 % to 45 %	Increments 1 %
---------------------------------	--------------	----------------

Functional Limits

Lower function limit phases	for $I_{Nom} = 1$ A	at least one phase current (50 Hz and 100 Hz) ≥ 50 mA	
	for $I_{Nom} = 5$ A	at least one phase current (50 Hz and 100 Hz) ≥ 125 mA	
Lower function limit ground	for $I_{Nom} = 1$ A	Ground current (50 Hz and 100 Hz) ≥ 50 mA	
	for $I_{Nom} = 5$ A	Ground current (50 Hz and 100 Hz) ≥ 125 mA	
Upper function limit, configurable	for $I_{Nom} = 1$ A	0.30 A to 25.00 A	Increments 0.01 A
	for $I_{Nom} = 5$ A	1.50 A to 125.00 A	Increments 0.01 A

Cross-blocking

Cross-blocking I_A, I_B, I_C	ON/OFF
--------------------------------	--------

4.6 Dynamic Cold Load Pickup

Timed Changeover of Settings

Controlled functions	Directional and non-directional time overcurrent protection (separated acc. to phases and Ground)
Initiation criteria	Current Criteria "BkrClosed I MIN"
	Interrogation of the circuit breaker position
	Automatic reclosing function ready
	Binary input
Time control	3 time elements ($T_{CB\ Open}$, T_{Active} , T_{Stop})
Current control	Current threshold "BkrClosed I MIN" (reset on current falling below threshold: monitoring with timer)

Setting Ranges / Increments

Current Control	for $I_{Nom} = 1\ A$	0.04 A to 1.00 A	Increments 0.01 A
	for $I_{Nom} = 5\ A$	0.20 A to 5.00 A	
Time Until Changeover To Dynamic Settings $T_{CB\ OPEN}$		0 s to 21600 s (= 6 h)	Increments 1 s
Period Dynamic Settings are Effective After a Reclosure T_{Active}		1 s to 21600 s (= 6 h)	Increments 1 s
Fast Reset Time T_{Stop}		1 s to 600 s (= 10 min) or ∞ (fast reset inactive)	Increments 1 s
Dynamic Settings of Pickup Currents and Time Delays or Time Multipliers		Adjustable within the same ranges and with the same increments as the directional and non-directional time overcurrent protection	

4.7 1-phase Overcurrent Protection

Current Elements

High-set current elements	50-2	0.001 A to 1.6 A or ∞ (element disabled) for $I_{Nom} = 1$ A 0.005 A to 8 A or ∞ (element disabled) for $I_{Nom} = 5$ A	Increments 0.001 A
	T_{50-2}	0.00 s to 60.00 s or ∞ (no trip)	Increments 0.01 s
Definite time current element	50-1	0.001 A to 1.6 A or ∞ (element disabled) for $I_{Nom} = 1$ A 0.005 A to 8 A or ∞ (element disabled) for $I_{Nom} = 5$ A	Increments 0.001 A
	T_{50-1}	0.00 s to 60.00 s or ∞ (no trip)	Increments 0.01 s

Operating Times

Pickup/Dropout Times		
Frequency Pickup Time	50 Hz	60 Hz
minimum	14 ms	13 ms
maximum	≤ 35 ms	≤ 35 ms
Dropout time approx.	25 ms	22 ms

Dropout Ratios

Current Elements	approx. 0.95 for $I/I_{Nom} \geq 0.5$
------------------	---------------------------------------

Tolerances

Currents	5 % of setting value or 1 mA
Times	1 % of setting value or 10 ms

Influencing Variables for Pickup Values

Auxiliary DC voltage in range $0.8 \leq V_{Aux}/V_{AuxNom} \leq 1.15$	1 %
Temperature in range $-5 \text{ °C (41 °F)} \leq \Theta_{amb} \leq 55 \text{ °C (131 °F)}$	0.5 %/10 K
Frequency in range of 25 Hz – 70 Hz	
Frequency in range of $0.95 \leq f/f_{Nom} \leq 1.05$ ($f_{Nom} = 50$ Hz or 60 Hz)	1 %
Frequency outside range $0.95 \leq f/f_{Nom} \leq 1.05$	Increased tolerances
Harmonics	
- up to 10 % 3rd harmonic	1 %
- up to 10 % 5th harmonic	1 %

4.8 Voltage Protection

4.8.1 Voltage Protection (Global standard)

Setting Ranges / Increments

Undervoltages 27-1, 27-2		
Measured quantity used With three-phase connection:	- Positive sequence system of the voltages - Smallest phase-to-phase voltage - Smallest phase-to-Ground voltage	
Measured quantity used with single-phase connection	Connected single-phase Phase-to-Ground voltage	
Connection of phase-to-Ground voltages: - Evaluation of phase-to-Ground voltages - Evaluation of phase-to-phase voltages - Evaluation of positive sequence system	10 V to 120 V 10 V to 210 V 10 V to 210 V	Increments 1 V Increments 1 V Increments 1 V
Connection of phase-to-phase voltages	10 V to 120 V	Increments 1 V
Connection: Single-phase	10 V to 120 V	Increments 1 V
Dropout ratio r for 27-1, 27-2 ¹⁾	1.01 to 3.00	Increments 0.01
Dropout threshold for (r· 27-1) or (r· 27-2)	max. 130 V for phase-to-phase voltage max. 225 V for phase-to-Ground voltage Minimum hysteresis 1.0 V	
Time delays T 27-1, T 27-2	0.00 s to 100.00 s or ∞ (disabled)	Increments 0.01 s
Current criterion "BkrClosed I MIN"	for I _{Nom} = 1 A	0.04 A to 1.00 A
	for I _{Nom} = 5 A	0.20 A to 5.00 A
Increments 0.01 A		
Overvoltages 59-1, 59-2		
Measured quantity used With three-phase connection:	- Positive sequence system of the voltages - Negative sequence system of the voltages - Largest phase-to-phase voltage - Largest phase-to-Ground voltage	
Measured quantity used with single-phase connection	Connected single-phase Phase-to-Ground voltage	
Connection of phase-to-Ground voltages: - Evaluation of phase-to-Ground voltages - Evaluation of phase-to-phase voltages - Evaluation of positive sequence system - Evaluation of negative sequence system	20 V to 150 V 20 V to 260 V 20 V to 150 V 2 V to 150 V	Increments 1 V Increments 1 V Increments 1 V Increments 1 V
Connection of phase-to-phase voltages: - Evaluation of phase-to-phase voltages - Evaluation of positive sequence system - Evaluation of negative sequence system	20 V to 150 V 20 V to 150 V 2 V to 150 V	Increments 1 V Increments 1 V Increments 1 V
Connection: Single-phase	20 V to 150 V	Increments 1 V
Dropout ratio r for 59-1, 59-2 ¹⁾	0.90 to 0.99	Increments 0.01
Dropout threshold for (r· 59-1) or (r· 59-2)	max. 150 V for phase-to-phase voltage max. 260 V for phase-to-Ground voltage Minimum hysteresis 0.6 V	
Time delay T 59-1, T 59-2	0.00 s to 100.00 s or ∞ (disabled)	Increments 0.01 s

1) $r = V_{\text{dropout}}/V_{\text{pickup}}$

Times

Pickup Times	
- Undervoltage 27-1, 27-2, 27-1 V ₁ , 27-2 V ₁	Approx. 50 ms
- Overvoltage 59-1, 59-2	Approx. 50 ms
- Overvoltage 59-1 V ₁ , 59-2 V ₁ , 59-1 V ₂ , 59-2 V ₂	Approx. 60 ms
Dropout Times	
- Undervoltage 27-1, 27-2, 27-1 V ₁ , 27-2 V ₁	Approx. 50 ms
- Overvoltage 59-1, 59-2	Approx. 50 ms
- Overvoltage 59-1 V ₁ , 59-2 V ₁ , 59-1 V ₂ , 59-2 V ₂	Approx. 60 ms

Tolerances

Voltage Limits	3 % of setting value or 1 V
Time delays T	1 % of setting value or 10 ms

Influencing Variables

Auxiliary DC voltage in range $0.8 \leq V_{\text{Aux}}/V_{\text{AuxNom}} \leq 1.15$	1 %
Temperature in range $-5 \text{ °C (41 °F)} \leq \Theta_{\text{amb}} \leq 55 \text{ °C (131 °F)}$	0.5 %/10 K
Frequency in range of 25 Hz – 70 Hz	
Frequency in range of $0.95 \leq f/f_{\text{Nom}} \leq 1.05$ ($f_{\text{Nom}} = 50 \text{ Hz or } 60 \text{ Hz}$)	1 %
Frequency outside range $0.95 \leq f/f_{\text{Nom}} \leq 1.05$	Increased tolerances
Harmonics	
- up to 10 % 3rd harmonic	1 %
- up to 10 % 5th harmonic	1 %

4.8.2 Voltage Protection (CEI 0-16 standard)

Setting Ranges / Increments

<u>Undervoltages 27.S1, 27.S2</u>		
Measured quantity used	- Smallest phase-to-phase voltage	
27.S1 or 27.S2	0.10Un to 1.20Un	Increments 0.01Un
Dropout ratio r for 27.S1, 27.S2 ¹⁾	1.01 to 3.00	Increments 0.01
Dropout threshold for (r · 27.S1) or (r · 27.S2)	max. 130 V for phase-to-phase voltage Minimum hysteresis 1.0 V	
Time delays T 27.S1, T 27.S2	0.05 s to 100.00 s or ∞(disabled)	Increments 0.01 s
<u>Overvoltages 59.S1, 59.S2</u>		
Measured quantity used	- Largest phase-to-phase voltage	
59.S1 or 59.S2	0.20Un to 1.50Un	Increments 0.01Un
Dropout ratio r for 59.S1, 59.S2 ¹⁾	0.90 to 0.99	Increments 0.01
Dropout threshold for (r · 59.S1) or (r · 59.S2)	max. 150 V for phase-to-phase voltage Minimum hysteresis 1.0 V	
Time delay T 59.S2	0.05 s to 100.00 s or ∞ (disabled)	Increments 0.01 s

$$1) r = V_{\text{dropout}} / V_{\text{pickup}}$$

Times

Pickup Times	
- Undervoltage 27.S1, 27.S2	Approx. 50 ms
- Overvoltage 59.S2	Approx. 30 ms
Dropout Times	
- Undervoltage 27.S1, 27.S2	Approx. 30 ms
- Overvoltage 59.S2	Approx. 30 ms

Tolerances

Voltage Limits	3 % of setting value or 1 V
Time delays T	1 % of setting value or 20 ms

Influencing Variables

Auxiliary DC voltage in range $0.8 \leq V_{\text{Aux}} / V_{\text{AuxNom}} \leq 1.15$	1 %
Temperature in range $-5 \text{ °C (41 °F)} \leq \Theta_{\text{amb}} \leq 55 \text{ °C (131 °F)}$	0.5 %/10 K
Frequency in range of 25 Hz – 70 Hz	
Frequency in range of $0.95 \leq f / f_{\text{Nom}} \leq 1.05$ ($f_{\text{Nom}} = 50 \text{ Hz or } 60 \text{ Hz}$)	1 %
Frequency outside range $0.95 \leq f / f_{\text{Nom}} \leq 1.05$	Increased tolerances
Harmonics	
- up to 10 % 3rd harmonic	1 %
- up to 10 % 5th harmonic	1 %

4.9 Negative Sequence Protection (definite-time characteristic)

Setting Ranges / Increments

Unbalanced load tripping element 46-1,46-2	for $I_{Nom} = 1 \text{ A}$	0.05 A to 3.00 A or ∞ (disabled)	Increments 0.01 A
	for $I_{Nom} = 5 \text{ A}$	0.25 A to 15.00 A or ∞ (disabled)	
Delay Times 46-1, 46-2		0.00 s to 60.00 s or ∞ (disabled)	Increments 0.01 s
Dropout Delay Times 46 T DROP-OUT		0.00 s to 60.00 s	Increments 0.01 s

Functional Limit

Functional Limit	for $I_{Nom} = 1 \text{ A}$	all phase currents $\leq 10 \text{ A}$
	for $I_{Nom} = 5 \text{ A}$	all phase currents $\leq 50 \text{ A}$
	for $I_{Nom} = 1 \text{ A}$	one phase current $\geq 0.05 \text{ A}$
	for $I_{Nom} = 5 \text{ A}$	one phase current $\geq 0.25 \text{ A}$

Times

Pickup Times	Approx. 35 ms
Dropout Times	Approx. 35 ms

Dropout Ratio

Characteristic 46-1, 46-2	Approx. 0.95 for $I_2/I_{Nom} \geq 0.3$
---------------------------	---

Tolerances

Pickup values 46-1, 46-2	3 % of setting value or 15 mA for $I_{Nom} = 1 \text{ A}$, or 75 mA for $I_{Nom} = 5 \text{ A}$
Time Delays	1 % or 10 ms

Influencing Variables for Pickup Values

Auxiliary DC voltage in range $0.8 \leq V_{Aux}/V_{AuxNom} \leq 1.15$	1 %
Temperature in range $-5 \text{ °C} (41 \text{ °F}) \leq \Theta_{amb} \leq 55 \text{ °C} (131 \text{ °F})$	0.5 %/10 K
Frequency in range of 25 Hz – 70 Hz	
Frequency in range of $0.95 \leq f/f_{Nom} \leq 1.05$ ($f_{Nom} = 50 \text{ Hz}$ or 60 Hz)	1 %
Frequency outside range $0.95 \leq f/f_{Nom} \leq 1.05$	Increased tolerances
Harmonics	
- up to 10 % 3rd harmonic	1 %
- up to 10 % 5th harmonic	1 %
Transient overreaction for $\tau > 100 \text{ ms}$ (with full displacement)	<5 %

4.10 Negative Sequence Protection (inverse-time characteristics)

Setting Ranges / Increments

Pickup value 46-TOC (I_{2p})	for $I_{Nom} = 1\text{ A}$	0.05 A to 2.00 A	Increments 0.01 A
	for $I_{Nom} = 5\text{ A}$	0.25 A to 10.00 A	
Time Multiplier T_{I2p} (IEC)		0.05 s to 3.20 s or ∞ (disabled)	Increments 0.01 s
Time Multiplier D_{I2p} (ANSI)		0.50 s to 15.00 s or ∞ (disabled)	Increments 0.01 s

Functional Limit

Functional Limit	for $I_{Nom} = 1\text{ A}$	all phase currents $\leq 10\text{ A}$
	for $I_{Nom} = 5\text{ A}$	all phase currents $\leq 50\text{ A}$

Trip Time Curves acc. to IEC

See also Figure 4-7	
INVERSE	$t_{TRIP} = \frac{0.14}{(I_2/I_{2p})^{0.02} - 1} \cdot T_{I2p} \quad [s]$
VERY INVERSE	$t_{TRIP} = \frac{13.5}{(I_2/I_{2p})^1 - 1} \cdot T_{I2p} \quad [s]$
EXTREMELY INV.	$t_{TRIP} = \frac{80}{(I_2/I_{2p})^2 - 1} \cdot T_{I2p} \quad [s]$
Where: t_{TRIP} Trip Time T_{I2p} Setting Value of the Time Multiplier I_2 Negative Sequence Current I_{2p} Setting Value of the Pickup Current	
The trip times for $I_2/I_{2p} \geq 20$ are identical to those for $I_2/I_{2p} = 20$.	
Pickup Threshold	Approx. $1.10 \cdot I_{2p}$

Trip Time Curves acc. to ANSI

It can be selected one of the represented trip time characteristic curves in the figures 4-8 and 4-9 each on the right side of the figure.	
INVERSE	$t_{TRIP} = \left(\frac{8.9341}{(I_2/I_{2p})^{2.0938} - 1} + 0.17966 \right) \cdot D_{I_{2p}} \quad [s]$
MODERATELY INVERSE	$t_{TRIP} = \left(\frac{0.0103}{(I_2/I_{2p})^{0.02} - 1} + 0.0228 \right) \cdot D_{I_{2p}} \quad [s]$
VERY INVERSE	$t_{TRIP} = \left(\frac{3.922}{(I_2/I_{2p})^2 - 1} + 0.0982 \right) \cdot D_{I_{2p}} \quad [s]$
EXTREMELY INV.	$t_{TRIP} = \left(\frac{5.64}{(I_2/I_{2p})^2 - 1} + 0.02434 \right) \cdot D_{I_{2p}} \quad [s]$
Where: t_{TRIP} Trip Time $D_{I_{2p}}$ Setting Value of the Time Multiplier I_2 Negative Sequence Currents I_{2p} Setting Value of the Pickup Current	
The trip times for $I_2/I_{2p} \geq 20$ are identical to those for $I_2/I_{2p} = 20$.	
Pickup Threshold	Approx. $1.10 \cdot I_{2p}$

Tolerances

Pickup threshold I_{2p}	3 % of setting value or 15 mA for $I_{Nom} = 1$ A or 75 mA at $I_{Nom} = 5$ A
Time for $2 \leq I/I_{2p} \leq 20$	5 % of reference (calculated) value +2 % current tolerance, or 30 ms

Dropout Time Curves with Disk Emulation acc. to ANSI

Representation of the possible dropout time curves, see figure 4-8 and 4-9 each on the left side of the figure

INVERSE	$t_{Reset} = \left(\frac{8.8}{1 - (I_2/I_{2p})^{2.0938}} \right) \cdot D_{I2p} \quad [s]$
MODERATELY INV.	$t_{Reset} = \left(\frac{0.97}{1 - (I_2/I_{2p})^2} \right) \cdot D_{I2p} \quad [s]$
VERY INVERSE	$t_{Reset} = \left(\frac{4.32}{1 - (I_2/I_{2p})^2} \right) \cdot D_{I2p} \quad [s]$
EXTREMELY INV.	$t_{Reset} = \left(\frac{5.82}{1 - (I_2/I_{2p})^2} \right) \cdot D_{I2p} \quad [s]$
<p>Where:</p> <ul style="list-style-type: none"> t_{Reset} Reset Time D_{I2p} Setting Value of the Time Multiplier I_2 Negative Sequence Current I_{2p} Setting Value of the Pickup Current 	
The dropout time constants apply to $(I_2/I_{2p}) \leq 0.90$	

Dropout Value

IEC and ANSI (without Disk Emulation)	Approx. $1.05 \cdot I_{2p}$ setting value, which is approx. $0.95 \cdot$ pickup threshold I_2
ANSI with Disk Emulation	Approx. $0.90 \cdot I_{2p}$ setting value

Tolerances

Dropout value I_{2p}	3 % of setting value or 15 mA for $I_{Nom} = 1$ A or 75 mA for $I_{Nom} = 5$ A
Time for $I_2/I_{2p} \leq 0.90$	5 % of reference (calculated) value +2 % current tolerance, or 30 ms

Influencing Variables for Pickup Values

Power Supply DC Voltage in Range $0,8 \leq V_{Aux}/V_{AuxNom} \leq 1.15$	1 %
Temperature in range $23.00 \text{ °F } (-5 \text{ °C}) \leq \Theta_{amb} \leq 131.00 \text{ °F } (55 \text{ °C})$	0.5 %/10 K
Frequency in range of 25 Hz – 70 Hz	
Frequency in range of $0.95 \leq f/f_{Nom} \leq 1.05$ ($f_{Nom} = 50$ Hz or 60 Hz)	1 %
Frequency in range $0.95 \leq f/f_{Nom} \leq 1.05$	Increased Tolerances
Harmonics	
- up to 10 % 3rd harmonic	1 %
- up to 10 % 5th harmonic	1 %
Transient overreaction for $\tau > 100$ ms (with full displacement)	<5 %

4.10 Negative Sequence Protection (inverse-time characteristics)

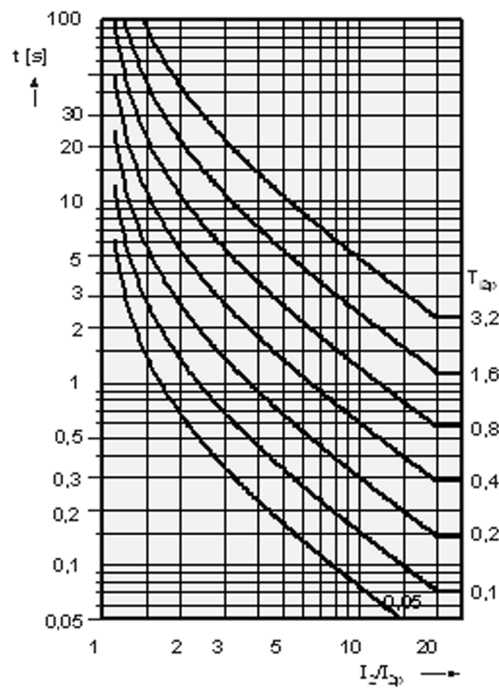
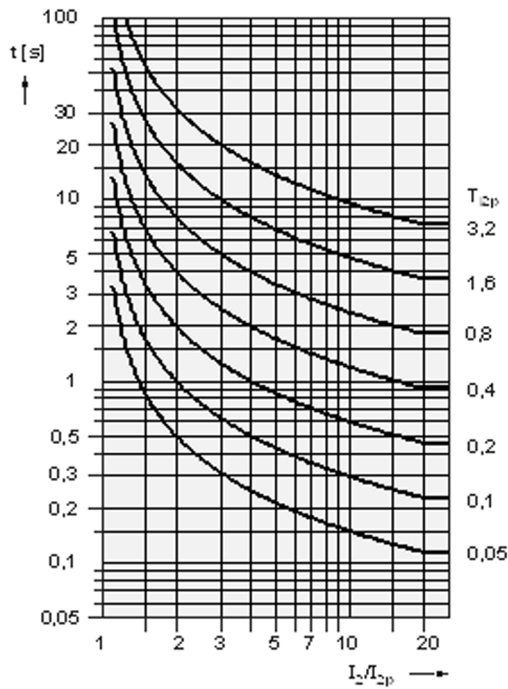

IEC INVERSE:
$$t = \frac{0,14}{(I_2/I_{2p})^{0,02} - 1} \cdot T_{I2p} \text{ [s]}$$

IEC VERY INVERSE:
$$t = \frac{13,5}{(I_2/I_{2p})^1 - 1} \cdot T_{I2p} \text{ [s]}$$

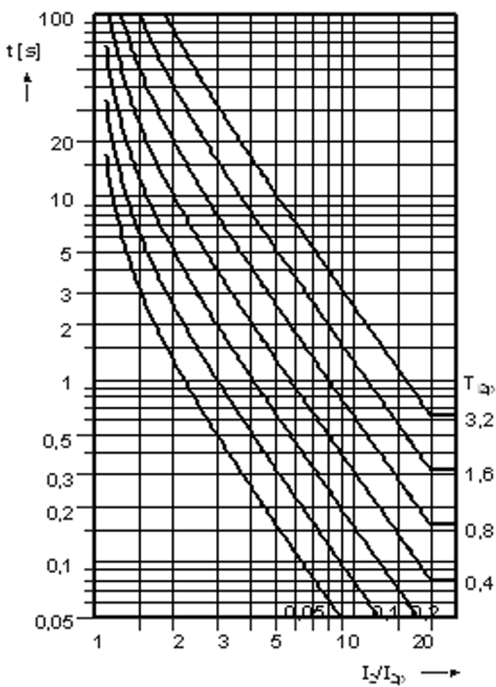

- t Tripping Time
- T_{I2p} Setting Value of the Time Factor
- I_2 Inverse current
- I_{2p} Pickup current of unbalanced load protection

IEC EXTREMELY INVERSE:
$$t = \frac{80}{(I_2/I_{2p})^2 - 1} \cdot T_{I2p} \text{ [s]}$$

Figure 4-7 Trip time characteristics of the inverse time negative sequence element 46-TOC, acc. to IEC

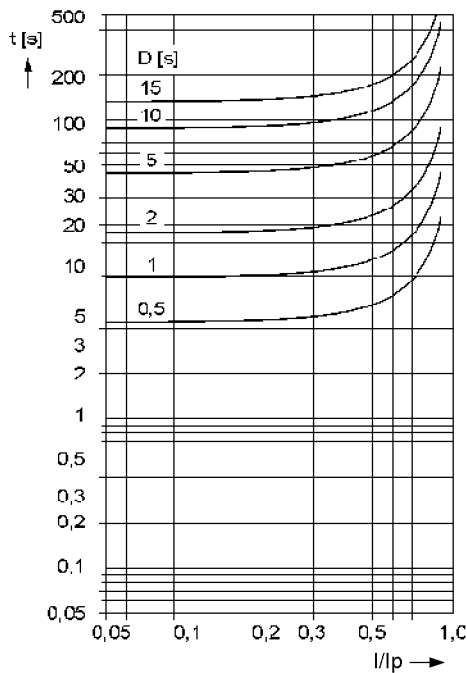

RESET INVERSE

$$t = \left(\frac{8.8}{1 - (I_2/I_{2p})^{2.0938}} \right) \cdot D \text{ [s]}$$

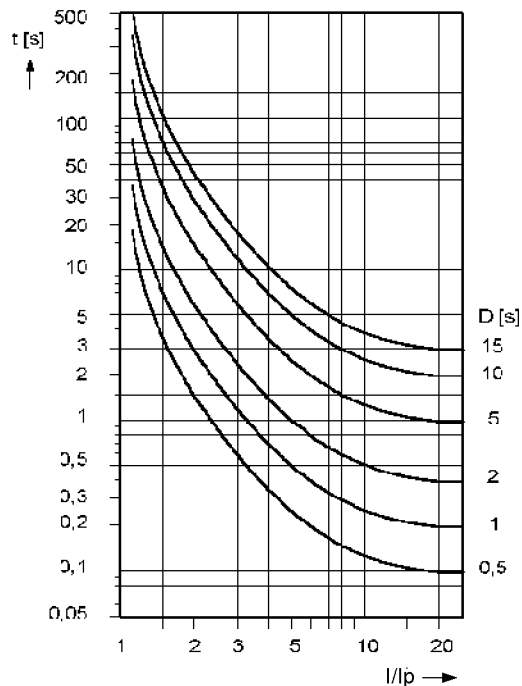

INVERSE

$$t = \left(\frac{8.9341}{(I_2/I_{2p})^{2.0938} - 1} + 0.17966 \right) \cdot D \text{ [s]}$$

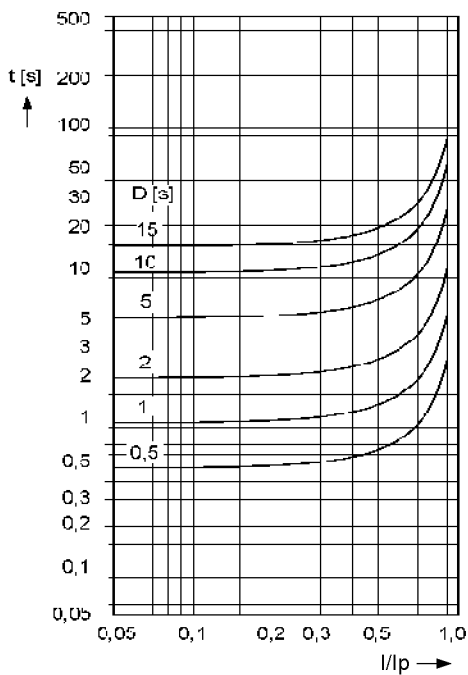

RESET MODERATELY INVERSE

$$t = \left(\frac{0.97}{1 - (I_2/I_{2p})^2} \right) \cdot D \text{ [s]}$$

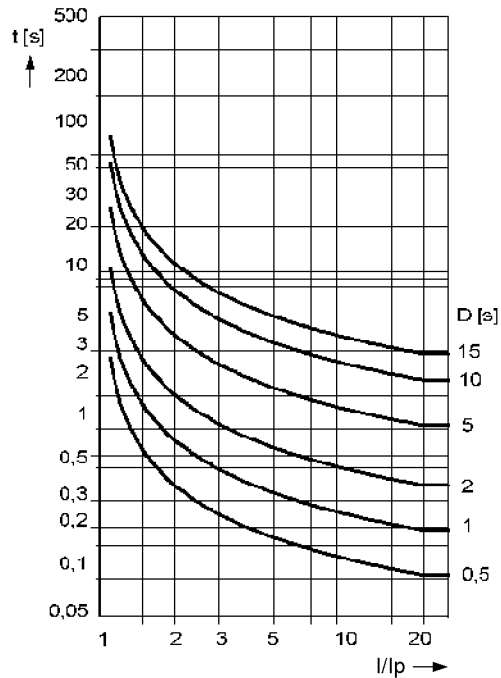

MODERATELY INVERSE

$$t = \left(\frac{0.0103}{(I_2/I_{2p})^{0.02} - 1} + 0.0228 \right) \cdot D \text{ [s]}$$

Figure 4-8 Dropout time and trip time characteristics of the inverse time unbalanced load stage, acc. to ANSI

4.10 Negative Sequence Protection (inverse-time characteristics)

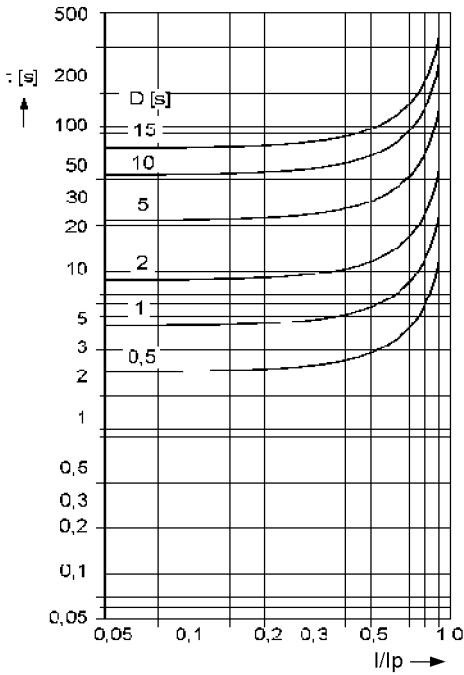

RESET VERY INVERSE

$$t = \left(\frac{4.32}{1 - (I_2/I_{2p})^2} \right) \cdot D \text{ [s]}$$

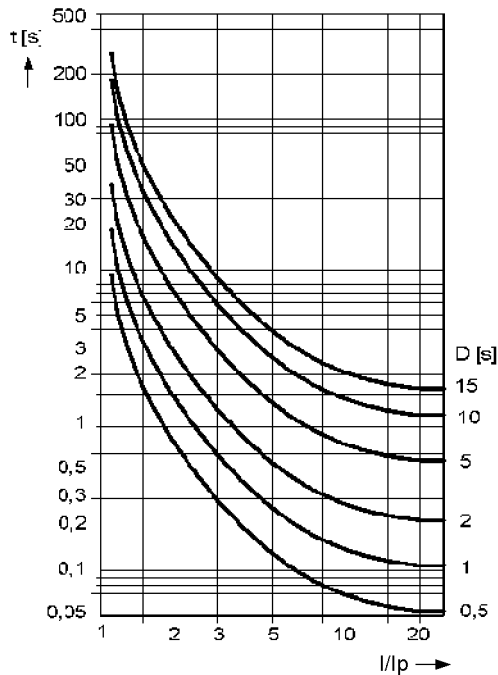

VERY INVERSE:

$$t = \left(\frac{3.922}{(I_2/I_{2p})^2 - 1} + 0.0982 \right) \cdot D \text{ [s]}$$

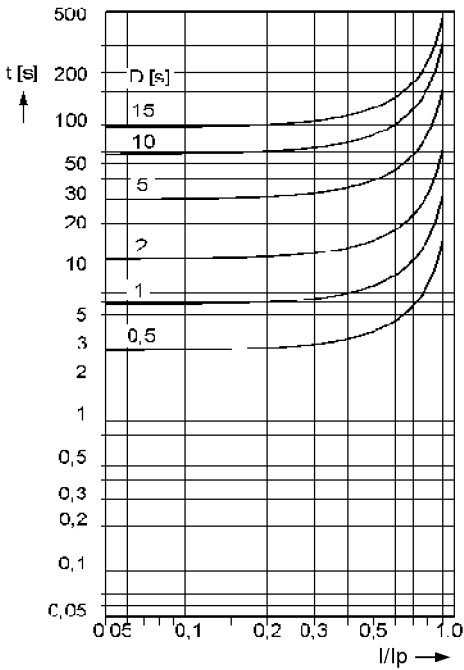

RESET EXTREMELY INVERSE

$$t = \left(\frac{5.82}{1 - (I_2/I_{2p})^2} \right) \cdot D \text{ [s]}$$

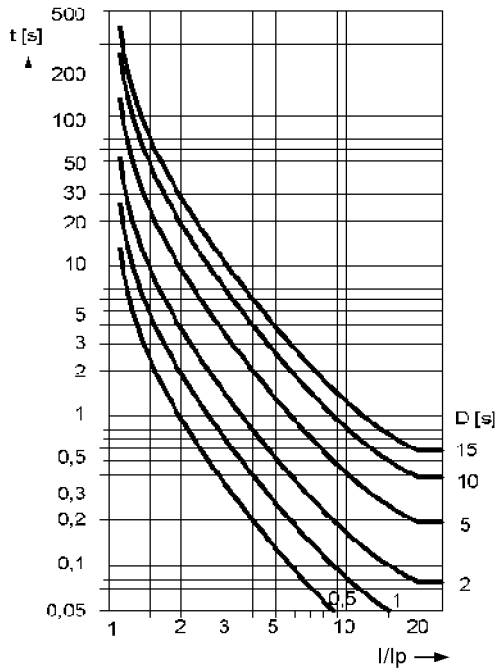

EXTREMELY INVERSE

$$t = \left(\frac{5.64}{(I_2/I_{2p})^2 - 1} + 0.02434 \right) \cdot D \text{ [s]}$$

Figure 4-9 Dropout time and trip time characteristics of the inverse time unbalanced load stage, acc. to ANSI

4.11 Frequency Protection

4.11.1 Frequency Protection 81 O/U (Global Standard)

Setting Ranges / Increments

Number of frequency elements	4; each can be set to f> or f<	
Pickup values f> or f< for $f_{Nom} = 50$ Hz	40.00 Hz to 60.00 Hz	Increments 0.01 Hz
Pickup values f> or f< for $f_{Nom} = 60$ Hz	50.00 Hz to 70.00 Hz	Increments 0.01 Hz
Dropout threshold = pickup threshold - dropout threshold	0.02 Hz to 1.00 Hz	Increments 0.01 Hz
Time delays T	0.00 s to 100.00 s or ∞ (dis-abled)	Increments 0.01 s
Undervoltage blocking with three-phase connection: Positive sequence component V_1 with single-phase connection (connection type "Vph-n, Vsyn"): single-phase Phase-to-ground voltage	10 V to 150 V	Increments 1 V

Times

Pickup times f>, f<	approx. 100 ms at $f_{Nom} = 50$ Hz approx. 80 ms at $f_{Nom} = 60$ Hz
Dropout times f>, f<	approx. 100 ms at $f_{Nom} = 50$ Hz approx. 80 ms at $f_{Nom} = 60$ Hz

Dropout Difference

$\Delta f = I$ pickup value - dropout value I	0.02 Hz to 1 Hz
---	-----------------

Dropout Ratio

Dropout Ratio for Undervoltage Blocking	approx. 1.05
---	--------------

Tolerances

Pickup frequencies 81/O or 81U Undervoltage blocking Time delays 81/O or 81/U	15 mHz (with $V = V_{nom}$, $f = f_{Nom} \pm 5$ Hz) 3 % of setting value or 1 V 1 % of setting value or 10 ms
---	--

Influencing Variables

Power supply direct voltage in range $0.8 \leq V_{PS}/V_{PSNom} \leq 1.15$	1 %
Temperature in range 23.00 °F (-5 °C) $\leq \theta_{amb} \leq 131.00$ °F (55 °C)	0.5 %/10 K
Harmonics - up to 10 % 3rd harmonic - up to 10 % 5th harmonic	1 % 1 %

4.11.2 Frequency Protection 81 O/U (CEI 0-16 Standard)

Setting Ranges / Increments

Frequency 81>. 81<		
Number of frequency elements	4; each can be switched ON/OFF	
Pickup frequency 81>	f _{Nom} = 50Hz	50.00 Hz to 60.00 Hz
	f _{Nom} = 60Hz	60.00 Hz to 70.00 Hz
Pickup frequency 81<	f _{Nom} = 50Hz	40.00 Hz to 50.00 Hz
	f _{Nom} = 60Hz	50.00 Hz to 60.00 Hz
Dropout threshold = pickup value - dropout value	0.02 Hz to 1.00 Hz	Increments 0.01 Hz
Time delays T	0.05 s to 100.00 s ;or ∞	Increments 0.01 s
Undervoltage Blocking	0.20 Un to 1.50 Un	Increments 0.01 Un
Dropout Ratio for Undervoltage Blocking	approx. 1.05	
zero sequence overvoltage 59V0		
59V0	0.01 Uen to 1.15 Uen	Increments 0.01 Uen
Dropout ratio r for 59V0 ¹⁾	0.90 to 0.99	Increments 0.01
Dropout threshold for (r· 59V0)	max. 200 V Minimum hysteresis 1.0 V	
Time delays T 59V0	0.05 s to 100.00 s ;or ∞	Increments 0.01 s
Voltage element 81V		
81V 27V1	0.10 Uphn to 1.20 Uphn	Increments 0.01 Uphn
81V 59V2	0.02 Uphn to 1.50 Uphn	Increments 0.01 Uphn
Dropout ratio r for 81V 27V1 ¹⁾	1.01 to 3.00	Increments 0.01
Dropout ratio r for 81V 59V2 ¹⁾	0.90 to 0.99	Increments 0.01
Dropout threshold for (r·81V 27V1)	max. 130 V Minimum hysteresis 1.0 V	
Dropout threshold for (r·81V 59V2)	max. 150 V Minimum hysteresis 1.0 V	

¹⁾ $r = V_{\text{dropout}} / V_{\text{pickup}}$

Times

Pickup times	
- 81> and 81<	Approx. 50 ms
- 59V0	Approx. 40 ms
- 81V	Approx. 40 ms
Dropout times	
- 81> and 81<	Approx. 40 ms
- 59V0	Approx. 40 ms
- 81V	Approx. 40 ms

Tolerances

Pickup Frequencies 81> or 81<	15 mHz (with $V = V_{Nom}$ and $f = f_{Nom}$)
Undervoltage blocking	20 mHz (with $V = V_{Nom}$ and $f \neq f_{Nom}$)
59V0, 81V	3 % of setting value or 1 V
Times delays 81> or 81<, 59V0	3 % of setting value or 1 V
	1 % of setting value or 20 ms

Influencing Variables

Power supply direct voltage in range $0.8 \leq V_{PS}/V_{PSNom} \leq 1.15$	1 %
Temperature in range $23.00 \text{ °F} (-5 \text{ °C}) \leq \Theta_{amb} \leq 131.00 \text{ °F} (55 \text{ °C})$	0.5 %/10 K
Harmonics	
- up to 10 % 3rd harmonic	1 %
- up to 10 % 5th harmonic	1 %

4.12 Undervoltage-controlled reactive power protection (27/Q)

Measured Values / Modes of Operation

3-phase	I1, V, Q,
Measuring method for I, V	Fundamental wave,
Pickup when	Exceeding threshold value or falling below threshold value

Setting Ranges / Increments

Pickup thresholds:			
Current I_1	for $I_{Nom} = 1\text{ A}$	0.02 to 0.20 A	Increments 0.01 A
	for $I_{Nom} = 5\text{ A}$	0.10 to 1.00 A	
Voltage V		10.0 to 210.00 V	Increments 0.1 V
Power Q	for $I_{Nom} = 1\text{ A}$	1.0 to 100 VAR	Increments 0.01 VAR
	for $I_{Nom} = 5\text{ A}$	5.0 to 500 VAR	
Pickup delay (standard)		0.00 to 60.00 s	Increments 0.01 s
Command delay time		0.00 to 3600.00 s	Increments 0.01 s
Dropout delay		0.00 to 60.00 s	Increments 0.01 s

Function Limits

Power measurement three-phase	for $I_{Nom} = 1\text{ A}$	Positive sequence system current > 0.03 A
	for $I_{Nom} = 5\text{ A}$	Positive sequence system current > 0.15 A

Times

Pickup times:	
QU protection typical maximum (small signals and thresholds)	approx. 120 ms approx. 350 ms
Binary input	approx. 20 ms
Dropout times:	
QU protection typical maximum	< 50 ms < 350 ms
Binary input	<10 ms

Dropout Ratio

U< Pickup	Approx. 1.02
U> Reclose	Approx. 0.98

Tolerances

Pickup thresholds:		
Current	for $I_{Nom} = 1 \text{ A}$	1% of setting value or 10 mA at $I_{Nom} \geq 0.03 \text{ A}$ 2% of setting value or 20 mA at $I_{Nom} < 0.03 \text{ A}$
	for $I_{Nom} = 5 \text{ A}$	1% of setting value or 50 mA at $I_{Nom} \geq 0.25 \text{ A}$ 2% of setting value or 100 mA at $I_{Nom} < 0.25 \text{ A}$
Current (symmetrical components)	for $I_{Nom} = 1 \text{ A}$	2% of setting value or 20 mA
	for $I_{Nom} = 5 \text{ A}$	2% of setting value or 100 mA
Voltage		1% of setting value or 0.1 V
Voltage (symmetrical components)		2% of setting value or 0.2 V
Power		1% of setting value or 0.3 VAR
Times		1% of setting value or 10 ms

Influencing Variables for Pickup Values

Auxiliary direct voltage in the range from $0.8 \leq V_{PS}/V_{PSNom} \leq 1.15$	1 %
Temperature in the range from $23.00 \text{ °F} (-5 \text{ °C}) \leq \theta_{amb} \leq 131.00 \text{ °F} (55 \text{ °C})$	0.5 %/10 K
Frequency in the range from 25 Hz to 70 Hz	1 %
Harmonics	
- up to 10 % 3rd harmonic	1 %
- up to 10 % 5th harmonic	1 %

4.13 Thermal Overload Protection

Setting ranges / increments

Factor k according to IEC 60255-8	0.10 to 4.00	Increments 0.01
Time constant τ_{th}	1.0 min to 999.9 min	Increments 0.1 min
Current alarm element I_{Alarm}	for $I_{Nom} = 1\text{ A}$	0.10 A to 4.00 A
	for $I_{Nom} = 5\text{ A}$	0.50 A to 20.00 A
Extension with machine at rest $k\tau$ factor	1.0 to 10.0 relative to the time constant for the machine running	Increments 0.1
Dropout time (emergency start) $T_{Emergency}$	10 s to 15000 s	Increments 1 s

Trip Characteristic

Formula for primary values:	
Trip Characteristic Curve for $(I/k \cdot I_{Nom}) \leq 8$	$t = \tau_{th} \cdot \ln \frac{\left(\frac{I}{k \cdot I_{Nom}}\right)^2 - \left(\frac{I_{pre}}{k \cdot I_{Nom}}\right)^2}{\left(\frac{I}{k \cdot I_{Nom}}\right)^2 - 1}$
Where:	<ul style="list-style-type: none"> t Trip Time in minutes τ_{th} Heating-up Time Constant I Actual Load Current I_{pre} Preload Current k Setting Factor per IEC 60255-8 I_{Nom} Nominal Current of the Protected Object

Dropout Ratios

Θ/Θ_{Trip}	Drops out with Θ_{Alarm}
Θ/Θ_{Alarm}	
I/I_{Alarm}	

Tolerances

Referring to $k \cdot I_{Nom}$	3 % or 15 mA for $I_{Nom} = 1\text{ A}$, or 75 mA for $I_{Nom} = 5\text{ A}$, 2 % class according to IEC 60255-8
Referring to trip time	3 % or 1 s for $I/(k \cdot I_{Nom}) > 1.25$; 3 % class according to IEC 60255-8

Influencing Variables Referring to $k \cdot I_{Nom}$

Auxiliary DC voltage in range $0,8 \leq V_{Aux}/V_{AuxNom} \leq 1.15$	1 %
Temperature in range -5 °C (41 °F) $\leq \Theta_{amb} \leq 55\text{ °C}$ (131 °F)	0.5 %/10 K
Frequency in range of 25 Hz – 70 Hz	
Frequency in the range of $0.95 \leq f/f_{Nom} \leq 1.05$ ($f_{Nom} = 50\text{ Hz}$ or 60 Hz)	1 %
Frequency outside range $0.95 \leq f/f_{Nom} \leq 1.05$	Increased tolerances

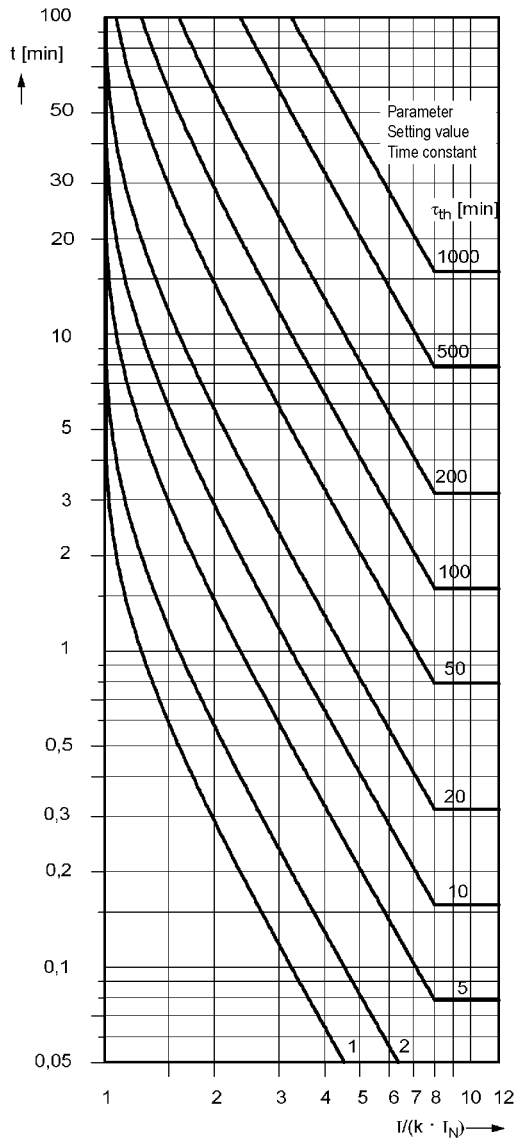

without pre-load:

$$t = \tau_{th} \cdot \ln \frac{\left(\frac{I}{k \cdot I_N}\right)^2}{\left(\frac{I}{k \cdot I_N}\right)^2 - 1} \text{ [min]}$$

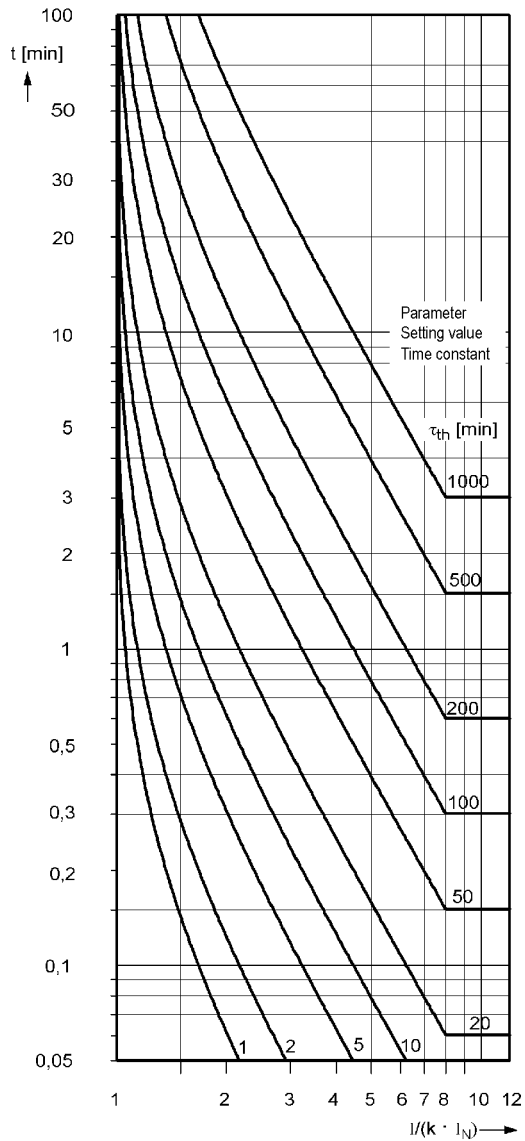

with 90 % pre-load:

$$t = \tau_{th} \cdot \ln \frac{\left(\frac{I}{k \cdot I_N}\right)^2 - \left(\frac{I_{pre}}{k \cdot I_N}\right)^2}{\left(\frac{I}{k \cdot I_N}\right)^2 - 1} \text{ [min]}$$

Figure 4-10 Trip time curves for the thermal overload protection (49)

4.14 Ground Fault Detection (Sensitive/Insensitive)

Displacement Voltage Element For all Types of Ground Faults

Displacement voltage, measured	$V_0 > 1.8 \text{ V}$ to 200.0 V	Increments 0.1 V
Displacement voltage, calculated	$3V_0 > 10.0 \text{ V}$ to 225.0 V	Increments 0.1 V
Pickup delay T-DELAY Pickup	0.04 s to 320.00 s or ∞	Increments 0.01 s
Additional tripping delay 64-1 DELAY	0.10 s to 40000.00 s or ∞ (disabled)	Increments 0.01 s
Operating time	approx. 50 ms	
Dropout value	0.95 or (pickup value – 0.6 V)	
Measurement tolerance $V_0 >$ (measured) $3V_0 >$ (calculated)	3 % of setting value or 0.3 V 3 % of setting value or 3 V	
Operating time tolerances	1 % of setting value or 10 ms	

Phase Detection for Ground Faults on an Ungrounded System

Measuring Principle	Voltage measurement (phase-Ground)	
$V_{\text{PHASE MIN}}$ (Ground Fault Phase)	10 V to 100 V	Increments 1V
$V_{\text{PHASE MAX}}$ (Healthy Phase)	10 V to 100 V	Increments 1V
Measurement Tolerance acc. to VDE 0435, Part 303	3 % of setting value or 1 V	

Ground Fault Pickup for All Types of Ground Faults (Definite Time Characteristic)

Pickup current 50Ns-2 PICKUP, 50Ns-1 PICKUP for sensitive 1 A transformer for sensitive 5 A transformer for normal 1 A transformer for normal 5 A transformer	0.001 A to 1.600 A 0.005 A to 8.000 A 0.05 A to 35.00 A 0.25 A to 175.00 A	Increments 0.001 A Increments 0.005 A Increments 0.01 A Increments 0.05 A
Time delay 50Ns-2 DELAY, 50Ns-1 DELAY	0.00 s to 320.00 s or ∞ (disabled)	Increments 0.01 s
Dropout time delay 50Ns T DROP-OUT	0.00 s to 60.00 s	Increments 0.01 s
Operating time	$\leq 50 \text{ ms}$ (non-directional) $\leq 50 \text{ ms}$ (directional)	
Dropout ratio	approx. 0.95 for 50Ns > 50 mA	
Measurement tolerance sensitive non-sensitive	3 % of setting value or 1 mA for $I_{\text{Nom}} = 1 \text{ A}$, or 5 mA for $I_{\text{Nom}} = 5 \text{ A}$ for setting values < 10 mA approx. 20 % 3 % of setting value or 15 mA for $I_{\text{Nom}} = 1 \text{ A}$, or 75 mA for $I_{\text{Nom}} = 5 \text{ A}$	
Operating time tolerance	1 % of setting value or 10 ms	

Ground Fault Pickup for All Types of Ground Faults (Inverse Time Characteristic)

User-defined characteristic (defined by a maximum of 20 value pairs of current and time delay in direction measurement method "cos phi and sin phi")		
Pickup current 51Ns for sensitive 1 A transformer for sensitive 5 A transformer for normal 1 A transformer for normal 5-A transformer	0.001 A to 1.400 A 0.005 A to 7.000 A 0.05 A to 4.00 A 0.25 A to 20.00 A	Increments 0.001 A Increments 0.005 A Increments 0.01 A Increments 0.05 A
Time multiplier T_{51Ns}	0.10 s to 4.00 s or ∞ (disabled)	Increments 0.01 s
Pickup threshold	Approx. $1.10 \cdot I_{51Ns}$	
Dropout ratio	Approx. $1.05 \cdot I_{51Ns}$ for $I_{51Ns} > 50$ mA	
Measurement tolerance sensitive	3 % of setting value or 1 mA at $I_{Nom} = 1$ A or 5 mA at $I_{Nom} = 5$ A for setting values < 10 mA approx. 20 %	
non-sensitive	3 % of setting value or 15 mA for $I_{Nom} = 1$ A or 75 mA for $I_{Nom} = 5$ A	
Operating time tolerance in linear range	7 % of reference (calculated) value for $2 \leq I/I_{51Ns} \leq 20 + 2$ % current tolerance, or 70 ms	

Influencing Variables

Auxiliary DC voltage in range $0,8 \leq V_{Aux}/V_{AuxNom} \leq 1.15$	1 %
Temperature in range $-5 \text{ }^\circ\text{C} (41 \text{ }^\circ\text{F}) \leq \Theta_{amb} \leq 55 \text{ }^\circ\text{C} (131 \text{ }^\circ\text{F})$	0.5 %/10 K
Frequency in range of 25 Hz – 70 Hz	
Frequency in range of $0.95 \leq f/f_{Nom} \leq 1.05$ ($f_{Nom} = 50$ Hz or 60 Hz)	1 %
Frequency outside range $0.95 \leq f/f_{Nom} \leq 1.05$	Increased tolerances
Harmonics - up to 10 % 3rd harmonic - up to 10 % 5th harmonic	1 % 1 %
Note: When using the sensitive transformer, the linear range of the measuring input for sensitive ground fault detection is from 0.001 A to 1.6 A or 0.005 A to 8.0 A, depending on parameter 205 CT SECONDARY. The function is however still preserved for larger currents.	

Direction Determination for all Types of Ground Fault with $\cos \varphi / \sin \varphi$ Measurement

Direction measurement	- I_N and V_N measured - $3I_0$ and $3V_0$ calculated	
Measuring principle	Active/reactive power measurement	
Measuring release RELEASE DIRECT. (current component perpendicular (90°) to directional limit line) for sensitive 1 A transformer for sensitive 5 A transformer for normal 1 A transformer for normal 5-A transformer	0.001 A to 1.600 A 0.005 A to 8.000 A 0.05 A to 35.00 A 0.25 A to 175.00 A	Increments 0.001 A Increments 0.005 A Increments 0.01 A Increments 0.05 A
Dropout ratio	Approx. 0.80	
Measurement method	$\cos \varphi$ and $\sin \varphi$	
Directional limit line PHI CORRECTION	-45.0° to +45.0°	Increments 0.1°
Dropout delay RESET DELAY	1 s to 60 s	Increments 1 s
Limitation of the directional areas using α_1 and α_2	1° to 15°	Increments 1°
Angle tolerance	3°	

Direction Determination for all Types of Ground Fault with V_0 / I_0 Measurement

Direction measurement	- I_N and V_N measured - $3I_0$ and $3V_0$ calculated	
Measuring principle	U_0 / I_0 phase angle measurement	
50Ns-1 element		
Minimum voltage 50Ns-1 V_{min} V_0 measured $3V_0$ calculated	0.4 V to 50 V 10 V to 90 V	Increments 0.1 V Increments 1 V
Phase angle 50Ns-1 Φ	- 180° to 180°	Increments 1°
Delta phase angle 50Ns-1 $\Delta\Phi$	0° to 180°	Increments 1°
50Ns-2 element		
Minimum voltage 50Ns-2 V_{min} V_0 measured $3V_0$ calculated	0.4 V to 50 V 10 V to 90 V	Increments 0.1 V Increments 1 V
Phase angle 50Ns-2 Φ	- 180° to 180°	Increments 1°
Delta phase angle 50Ns-2 $\Delta\Phi$	0° to 180°	Increments 1°

Angle Correction

Angle correction for cable converter in two operating points F1/I1 and F2/I2:		
Angle correction F1, F2 (for resonant-grounded system)	0.0° to 5.0°	Increments 0.1°
Current values I1, I2 for angle correction for sensitive 1 A transformer for sensitive 5 A transformer for normal 1 A transformer for normal 5 A transformer	0.001 A to 1.600 A 0.005 A to 8.000 A 0.05 A to 35.00 A 0.25 A to 175.00 A	Increments 0.001 A Increments 0.005 A Increments 0.01 A Increments 0.05 A
Measurement tolerance sensitive non-sensitive	3 % of setting value or 1 mA at $I_N = 1$ A or 5 mA at $I_{Nom} = 5$ A for setting values < 10 mA approx. 20 % 3 % of setting value or 15 mA at $I_{Nom} = 1$ A or 75 mA at $I_{Nom} = 5$ A	
Angle tolerance	3°	
Note: Due to the high sensitivity, the linear range of the measuring input I_{Nom} with integrated sensitive input transformer is from $0.001 \cdot I_{Nom}$ to $1.6 \cdot I_{Nom}$. For currents greater than $1.6 \cdot I_{Nom}$, correct direction determination can no longer be guaranteed.		

4.15 Intermittent Ground Fault Protection

Setting Ranges / Increments

Pickup threshold with I _{Nom}	for I _{Nom} = 1 A	0.05 A to 35.00 A	Increments 0.01 A
	for I _{Nom} = 5 A	0.25 A to 175.00 A	Increments 0.01 A
with 3I0	for I _{Nom} = 1 A	0.05 A to 35.00 A	Increments 0.01 A
	for I _{Nom} = 5 A	0.25 A to 175.00 A	Increments 0.01 A
with I _N	for I _{Nom} = 1 A	0.005 A to 1.500 A	Increments 0.001 A
	for I _{Nom} = 5 A	0.025 A to 7.500 A	Increments 0.001 A
Pickup extension time T _v		0.00 s to 10.00 s	Increments 0.01 s
Ground Fault Accumulation Time T _{sum}		0.00 s to 100.00 s	Increments 0.01 s
Reset Time for Accumulation T _{res}		1 s to 600 s	Increments 1 s
Number of Pickups for Intermittent Ground Faults		2 to 10	Increments 1

Times

Pickup Times	
– Current = 1.25 x Pickup Value	Approx. 30 ms
– for ≥ 2 · Pickup Value	Approx. 22 ms
Dropout Time (without extension time)	Approx. 22 ms

Tolerances

Pickup threshold I	3 % of setting value or 10 mA for I _{Nom} = 1 A or 50 mA for I _{Nom} = 5 A
Times T _v , T _{sum} , T _{res}	1 % of setting value or 10 ms

Influencing Variables

Power supply direct voltage in range $0.8 \leq V_{PS}/V_{PSNom} \leq 1.15$	<1 %
Temperature in range $23.00 \text{ °F } (-5 \text{ °C}) \leq \Theta_{amb} \leq 131.00 \text{ °F } (55 \text{ °C})$	<0.5 %/ K
Frequency in range 25 Hz to 70 Hz	<5% relating to the set time

4.16 Directional intermittent ground fault protection

Setting Ranges / Increments

Pickup threshold V _{gnd> / 3V0>}	2.0 V to 100.0 V	Increments 1 V
Monitoring time after pickup detected	0.04 s ... 10.00 s	Increments 0.01 s
Pulse no. for detecting the intern. E/F	2 ... 50	Increments 1

Dropout ratio

Dropout ratio V _{gnd> / 3V0>}	0,95 or (pickup value - 0,6 V)
--	--------------------------------

Tolerances

Measurement tolerance V _{gnd> / 3V0>}	3 % of setting value
Times	1 % of setting value or 10 ms

Influencing Variables

Power supply direct voltage in range $0.8 \leq V_{PS}/V_{PSNom} \leq 1.15$	<1 %
Temperature in range $23.00 \text{ °F } (-5 \text{ °C}) \leq \Theta_{amb} \leq 131.00 \text{ °F } (55 \text{ °C})$	<0.5 %/ K

4.17 Automatic Reclosing System 79

Number of reclosures	0 to 9 (separately for phase and ground) Cycles 1 to 4 can be adjusted individually	
The following protection functions initiate the 79 AR (no 79 start / 79 start / 79 blocked)	50-3, 50-2, 50-1, 51, 67-3, 67-2, 67-1, 67-TOC, 50N-3, 50N-2, 50N-1, 51N, 67N-3, 67N-2, 67N-1, 67N-TOC sensitive ground fault detection, unbalanced load, binary input	
Blocking of 79 AR by	Pickup of protection functions for which 79 AR blocking is set (see above)	
	Three-phase pickup (optional)	
	Binary input	
	Last trip command after the reclosing cycle is complete (unsuccessful reclosing)	
	Trip command from the breaker failure protection	
	Opening of the circuit breaker without 79 AR start	
	External CLOSE Command	
Dead times T_{Dead} (separately for phase and ground and individually for cycles 1 to 4)	0.01 s to 320.00 s	Increments 0.01 s
	Using binary input with time monitoring	
Extension of dead time	Using binary input with time monitoring	
Blocking duration for manual CLOSE detection $T_{Blk Manual Close}$	0.50 s to 320.00 s or ∞	Increments 0.01 s
Blocking duration after reclosing $T_{Blk Time}$	0.50 s to 320.00 s	Increments 0.01 s
Blocking duration after dynamic blocking $T_{Blk Dyn}$	0.01 s to 320.00 s	Increments 0.01 s
Start signal monitoring time $T_{Start Monitor}$	0.01 s to 320.00 s or ∞	Increments 0.01 s
Circuit breaker monitoring time $T_{CB Monitor}$	0.10 s to 320.00 s	Increments 0.01 s
Maximum dead time extension $T_{Dead Exten}$	0.50 s to 320.00 s or ∞	Increments 0.01 s
Start delay of dead time	Using binary input with time monitoring	
Max. start delay of dead time $T_{Dead Delay}$	0.0 s to 1800.0 s or ∞	Increments 1.0 s
Operating time T_{Operat}	0.01 s to 320.00 s or ∞	Increments 0.01 s
The following protection functions can be influenced by the automatic reclosing function individually for cycles 1 to 4 (setting value $T=T/$ instantaneous $T=0/$ blocked $T=infinite$):	50-3, 50-2, 50-1, 51, 67-3, 67-2, 67-1, 67-TOC, 50N-3, 50N-2, 50N-1, 51N, 67N-3, 67N-2, 67N-1, 67N-TOC	
Additional functions	Final trip Circuit breaker monitoring by evaluating the auxiliary contacts Synchronous closing (optionally with integrated or external synchrocheck)	

4.18 Fault Locator

Units of Distance Measurement		in Ω primary and secondary in km or miles line length or in % of line length ¹⁾	
Trigger		trip command, Dropout of an Element, or External command via binary input	
Reactance Setting (secondary)	for $I_{Nom} = 1 \text{ A}$	0.0050 to 9.5000 Ω/km	Increments 0.0001
		0.0050 to 15.0000 Ω/mile	Increments 0.0001
	for $I_{Nom} = 5 \text{ A}$	0.0010 to 1.9000 Ω/km	Increments 0.0001
		0.0010 to 3.0000 Ω/mile	Increments 0.0001
For the remaining parameters refer to the Power System Data 2.			
When configuring mixed lines, the reactance value must be set for each line section (A1 to A3).			
Measurement Tolerance acc. to VDE 0435, Part 303 for Sinusoidal Measurement Quantities		2.0 % fault location (without intermediate infeed) $30^\circ \leq \varphi_K \leq 90^\circ$ and $V_K/V_{Nom} \geq 0.1$ and $I_K/I_{Nom} \geq 1.0$	

¹⁾ Homogeneous lines or correctly configured line sections are assumed when the fault distance is given in km, miles or %.

4.19 Breaker Failure Protection 50BF

Setting Ranges / Increments

Pickup threshold 50-1 BF	for $I_{Nom} = 1 \text{ A}$	0.05 A to 20.00 A	Increments 0.01 A
	for $I_{Nom} = 5 \text{ A}$	0.25 A to 100.00 A	
Pickup threshold 50N-1 BF	for $I_{Nom} = 1 \text{ A}$	0.05 A to 20.00 A	Increments 0.01 A
	for $I_{Nom} = 5 \text{ A}$	0.25 A to 100.00 A	
Time delay 50 BF trip timer		0.06 s to 60.00 s or ∞	Increments 0.01 s

Times

Pickup times - for internal start - for external start	Included in time delay Included in time delay
Dropout time Dropout ratio	approx. 25 ms = 0,95 (minimal hysteresis between pickup and tripping $\geq 32,5 \text{ mA}$)

Tolerances

Pickup threshold 50-1 BF, 50N-1 BF	3 % of setting value, or 15 mA for $I_{Nom} = 1 \text{ A}$ or 75 mA for $I_{Nom} = 5 \text{ A}$
Time delay 50 BF trip timer	1 % or 20 ms

Influencing Variables for Pickup Values

Auxiliary DC voltage in range $0.8 \leq V_{Aux}/V_{AuxNom} \leq 1.15$	1 %
Temperature in range $-5 \text{ °C (41 °F)} \leq \Theta_{amb} \leq 55 \text{ °C (131 °F)}$	0.5 %/10 K
Frequency in range $0.95 \leq f/f_{Nom} \leq 1.05$	1 %
Harmonics - up to 10 % 3rd harmonic - up to 10 % 5th harmonic	1 % 1 %

1) A further delay for the current may be caused by compensation in the secondary CT circuit.

4.20 Flexible Protection Functions

Measured Values / Modes of Operation

Three-phase	I, $3I_0$, I1, I2, I2/I1, V, $3V_0$, V1, V2, dV/dt, P forward, P reverse, Q forward, Q reverse, $\cos\varphi$
Single-phase	I, I_N , I_{Ns} , I_{N2} , V, V_N , V_x , P forward, P reverse, Q forward, Q reverse, $\cos\varphi$
Without fixed phase reference	f, df/dt, binary input
Measurement method for I, V	Fundamental, r.m.s. value (true RMS), positive sequence system, negative sequence system, zero sequence system
Pickup on	exceeding threshold value or falling below threshold value

Setting Ranges / Increments

Pickup thresholds:			
Current I, I ₁ , I ₂ , $3I_0$, I_N	for $I_N = 1\text{ A}$	0.05 A to 40.00 A	Increments 0.01 A
	for $I_N = 5\text{ A}$	0.25 A to 200.00 A	
Relationship I_2/I_1		15 % to 100 %	Increments 1%
Sensitive ground current I_{Ns}		0.001 A to 1.500 A	Increments 0.001 A
Voltage V, V ₁ , V ₂ , $3V_0$		2.0 V to 260.0 V	Increments 0.1 V
Displacement voltage V_N		2.0 V to 200.0 V	Increments 0.1 V
Power P, Q	for $I_N = 1\text{ A}$	2.0 W to 10000 W	Increment 0.1 W
	for $I_N = 5\text{ A}$	10 W to 50000 W	
Power factor $\cos\varphi$		-0.99 to +0.99	Increments 0.01
Frequency	for $f_{Nom} = 50\text{ Hz}$	40.0 Hz to 60.0 Hz	Increments 0.01 Hz
	for $f_{Nom} = 60\text{ Hz}$	50.0 Hz to 70.0 Hz	Increments 0.01 Hz
Frequency change df/dt		0.10 Hz/s to 20.00 Hz/s	Increments 0.01 Hz/s
Voltage change dV/dt		4 V/s to 100 V/s	Increments 1 V/s
Dropout ratio > element		1.01 to 3.00	Increments 0.01
Dropout ratio < element		0.70 to 0.99	Increments 0.01
Dropout difference f		0.02 Hz to 1.00 Hz	Increments 0.01 Hz
Pickup delay (standard)		0.00 s to 60.00 s	Increments 0.01 s
Pickup delay for I_2/I_1		0.00 s to 28800.00 s	Increments 0.01 s
Command delay time		0.00 s to 3600.00 s	Increments 0.01 s
Dropout delay		0.00 s to 60.00 s	Increments 0.01 s

Fixed Dropout Difference

Dropout difference df/dt	0.1 Hz/s
Dropout difference dV/dt	3 V/s

Function Limits

Power measurement three-phase	for $I_{Nom} = 1 \text{ A}$	Positive sequence system current > 0.03 A
	for $I_{Nom} = 5 \text{ A}$	Positive sequence system current > 0.15 A
Power measurement single-phase	for $I_{Nom} = 1 \text{ A}$	Phase current > 0.03 A
	for $I_{Nom} = 5 \text{ A}$	Phase current > 0.15 A
Relationship I_2/I_1 measurement	for $I_{Nom} = 1 \text{ A}$	Positive or negative sequence system current > 0.1 A
	for $I_{Nom} = 5 \text{ A}$	Positive or negative sequence system current > 0.5 A

Times

Pickup times:	
Current, voltage (phase quantities) for 2 times the setting value for 10 times the setting value	approx. 30 ms approx. 20 ms
Current, voltage (symmetrical components) for 2 times the setting value for 10 times the setting value	approx. 40 ms approx. 30 ms
Power typical maximum (small signals and threshold values)	approx. 120 ms approx. 350 ms
Power factor	300 to 600 ms
Frequency	approx. 100 ms
Frequency change for 1.25 times the setting value	approx. 220 ms
Voltage change dV/dt for 2 times the setting value	approx. 220 ms
Binary input	approx. 20 ms
Dropout times:	
Current, voltage (phase quantities)	< 20 ms
Current, voltage (symmetrical components)	< 30 ms
Power typical maximum	< 50 ms < 350 ms
Power factor	< 300 ms
Frequency	< 100 ms
Frequency change	< 200 ms
Voltage change	<200 ms
Binary input	< 10 ms

Tolerances

Pickup thresholds:		
Current	for $I_{Nom} = 1\text{ A}$	3% of setting value or 15 mA
	for $I_{Nom} = 5\text{ A}$	3% of setting value or 75 mA
Current (symmetrical components)	for $I_{Nom} = 1\text{ A}$	4% of setting value or 20 mA
	for $I_{Nom} = 5\text{ A}$	4% of setting value or 100 mA
Current (I_2/I_1)		4% of setting value
Voltage		3% of setting value or 0.2 V
Voltage (symmetrical components)		4% of setting value or 0.2 V
Voltage change dV/dt		5 % of setting value or 2 V/s
Power	for $I_{Nom} = 1\text{ A}$	3% of setting value or 0.5 W
	for $I_{Nom} = 5\text{ A}$	3% of setting value or 2.5 W
Power factor		3°
Frequency		15 mHz
Frequency change		5% of setting value or 0.05 Hz/s
Times		1% of setting value or 10 ms

Influencing Variables for Pickup Values

Auxiliary DC voltage in range $0.8 \leq V_{Aux}/V_{AuxNom} \leq 1.15$	1 %
Temperature in range $-5\text{ °C (41 °F)} \leq \Theta_{amb} \leq 55\text{ °C (131 °F)}$	0.5 %/10 K
Frequency in range of 25 Hz to 70 Hz	
Frequency in the range of $0.95 \leq f/f_{Nom} \leq 1.05$ ($f_{Nom} = 50\text{ Hz}$ or 60 Hz)	1 %
Frequency outside range $0.95 \leq f/f_{Nom} \leq 1.05$	Increased tolerances
Harmonics	
- up to 10 % 3rd harmonic	1 %
- up to 10 % 5th harmonic	1 %

4.21 Synchrocheck 25

Modes of Operation

- Synchrocheck

Additional Release Conditions

- Live bus / dead line, - Dead bus / live line, - Dead bus and dead line - Bypassing

Voltages

Maximum operating voltage V_{max}	20 V to 140 V (phase-to-phase)	Increments 1 V
Minimum operating voltage V_{min}	20 V to 125 V (phase-to-phase)	Increments 1 V
$V<$ for dead line $V>$ for live line	1 V to 60 V (phase-to-phase) 20 V to 140 V (phase-to-phase)	Increments 1 V Increments 1 V
Primary transformer rated voltage $V2N$	0.10 kV to 800.00 kV	Increments 0.01 kV
Tolerances	2 % of pickup value or 2 V	
Dropout Ratios	approx. 0.9 ($V>$) or 1.1 ($V<$)	

Permissible Differences

Voltage differences $V2>V1$; $V2<V1$ Tolerance	0.5 V to 50.0 V (phase-to-phase) 1 V	Increments 0.1 V
Frequency difference $f2>f1$; $f2<f1$ Tolerance	0.01 Hz to 2.00 Hz 30 mHz	Increments 0.01 Hz
Angle differences $\alpha2 > \alpha1$; $\alpha2 < \alpha1$ Tolerance	2° to 80° 2°	Increments 1°
Max. angle error	5° for $\Delta f \leq 1$ Hz 10° for $\Delta f \leq 1$ Hz	

Matching

Vector group matching via angle	0° to 360°	Increments 1°
Different voltage transformer $V1/V2$	0.50 to 2.00	Increments 0.01

Times

Minimum Measuring Time	approx. 80 ms	
Maximum Duration $T_{SYN DURATION}$	0.01 s to 1200.00 s or ∞ (disabled)	Increments 0.01 s
Monitoring Time $T_{SUP VOLTAGE}$	0.00 s to 60.00 s	Increments 0.01 s
Tolerance of all times	1 % of setting value or 10 ms	

Measured Values of the Synchrocheck Function

Reference voltage V1 - Range - Tolerance ¹⁾	in kV primary, in V secondary or in % of V_{Nom} 10 % to 120 % of V_{Nom} ≤ 1 % of measured value, or 0.5 % of V_{Nom}
Voltage to be synchronized V2 - Range - Tolerance ¹⁾	in kV primary, in V secondary or in % of V_{Nom} 10 % to 120 % of V_{Nom} ≤ 1 % of measured value, or 0.5 % of V_{Nom}
Frequency of the voltage V1 - Range - Tolerance ¹⁾	f1 in Hz 25 Hz $\leq f \leq$ 70 Hz 20 mHz
Frequency of the voltage V2 - Range - Tolerance ¹⁾	f2 in Hz 25 Hz $\leq f \leq$ 70 Hz 20 mHz
Voltage difference V2-V1 - Range - Tolerance ¹⁾	in kV primary, in V secondary or in % of V_{Nom} 10 % to 120 % of V_{Nom} ≤ 1 % of measured value, or 0.5 % of V_{Nom}
Frequency difference f2-f1 - Range - Tolerance ¹⁾	in mHz $f_{Nom} \pm 3$ Hz 30 mHz
Angle difference $\alpha_2 - \alpha_1$ - Range - Tolerance ¹⁾	in $^\circ$ 0 to 180 $^\circ$ 1 $^\circ$

¹⁾ at nominal frequency

4.22 User-defined Functions (CFC)

Function Blocks and Their Possible Assignments to Task Levels

Function block	Explanation	Task level			
		MW_ BEARB	PLC1_ BEARB	PLC_ BEARB	SFS_ BEARB
ABSVALUE	Magnitude Calculation	X	—	—	—
ADD	Addition	X	X	X	X
ALARM	Alarm	X	X	X	X
AND	AND - Gate	X	X	X	X
BLINK	Blink block	X	X	X	X
BOOL_TO_CO	Boolean to Control (conversion)	—	X	X	—
BOOL_TO_DI	Boolean to Double Point (conversion)	—	X	X	X
BOOL_TO_IC	Bool to Internal SI, Conversion	—	X	X	X
BUILD_DI	Create Double Point Annunciation	—	X	X	X
CMD_CANCEL	Cancel command	X	X	X	X
CMD_CHAIN	Switching Sequence	—	X	X	—
CMD_INF	Command Information	—	—	—	X
COMPARE	Metered value comparison	X	X	X	X
CONNECT	Connection	—	X	X	X
COUNTER	Counter	X	X	X	X
DI_GET_STATUS	Decode status of double-point indication	X	X	X	X
DI_SET_STATUS	Generate double-point indication with status	X	X	X	X
D_FF	D- Flipflop	—	X	X	X
D_FF_MEMO	Status Memory for Restart	X	X	X	X
DI_TO_BOOL	Double Point to Boolean (conversion)	—	X	X	X
DINT_TO_REAL	Adaptor	X	X	X	X
DIST_DECODE	Convert double-point indication with status into four single-point indications with status	X	X	X	X
DIV	Division	X	X	X	X
DM_DECODE	Decode Double Point	X	X	X	X
DYN_OR	Dynamic OR	X	X	X	X
INT_TO_REAL	Conversion	X	X	X	X
IO_UNIT	SICAM I/O Unit		X	X	
LIVE_ZERO	Live-zero, non-linear Curve	X	—	—	—
LONG_TIMER	Timer (max.1193h)	X	X	X	X
LOOP	Feedback Loop	X	X	—	X

Function block	Explanation	Task level			
		MW_ BEARB	PLC1_ BEARB	PLC_ BEARB	SFS_ BEARB
LOWER_SETPOINT	Lower Limit	X	—	—	—
MUL	Multiplication	X	X	X	X
MV_GET_STATUS	Decode status of a value	X	X	X	X
MV_SET_STATUS	Set status of a value	X	X	X	X
NAND	NAND - Gate	X	X	X	X
NEG	Negator	X	X	X	X
NOR	NOR - Gate	X	X	X	X
OR	OR - Gate	X	X	X	X
REAL_TO_DINT	Adaptor	X	X	X	X
REAL_TO_INT	Conversion	X	X	X	X
REAL_TO_UINT	Conversion	X	X	X	X
RISE_DETECT	Edge detector	X	X	X	X
RS_FF	RS- Flipflop	—	X	X	X
RS_FF_MEMO	RS- Flipflop with status memory	—	X	X	X
SQUARE_ROOT	Root Extractor	X	X	X	X
SR_FF	SR- Flipflop	—	X	X	X
SR_FF_MEMO	SR- Flipflop with status memory	—	X	X	X
ST_AND	AND gate with status	X	X	X	X
ST_NOT	Inverter with status	X	X	X	X
ST_OR	OR gate with status	X	X	X	X
SUB	Substraction	X	X	X	X
TIMER	Timer	—	X	X	—
TIMER_SHORT	Simple timer	—	X	X	—
UINT_TO_REAL	Conversion	X	X	X	X
UPPER_SETPOINT	Upper Limit	X	—	—	—
X_OR	XOR - Gate	X	X	X	X
ZERO_POINT	Zero Supression	X	—	—	—

Device-specific CFC Blocks

Table 4-1 ASWITCH – This block is used to switch between two REAL inputs (RMS values).

	Name	Type	Description	Default function
Input	SWITCH	BOOL	Analog value selection	FALSE
	IN1	REAL	Analog value	0.0
	IN2	REAL	Analog value	0.0
Output	OUT	REAL	Selected analog value	

Task levels:	<p>Recommendation: Into task levels PLC1_BEARB and PLC_BEARB, because these levels are directly triggered. Note: If you use thi block in the task levels MW_BEARB and SFS_BEARB, a change of the SWITCH signal is only recognized if the signal lasts longer than the processing cycle of the task level.</p>						
Behavior of inputs and outputs:	<table border="1"> <thead> <tr> <th>SWITCH</th> <th>OUT</th> </tr> </thead> <tbody> <tr> <td>0</td> <td>IN1</td> </tr> <tr> <td>1</td> <td>IN2</td> </tr> </tbody> </table>	SWITCH	OUT	0	IN1	1	IN2
SWITCH	OUT						
0	IN1						
1	IN2						

General Limits

Description	Limit	Comment
Maximum number of all CFC charts considering all task levels	32	If the limit is exceeded, the device rejects the parameter set with an error message, restores the last valid parameter set and restarts using that parameter set.
Maximum number of all CFC charts considering one task level	16	When the limit is exceeded, an error message is output by the device. Consequently, the device starts monitoring. The red ERROR-LED lights up.
Maximum number of all CFC inputs considering all charts	400	When the limit is exceeded, an error message is output by the device. Consequently, the device starts monitoring. The red ERROR-LED lights up.
Maximum number of reset-resistant flipflops D_FF_MEMO	350	When the limit is exceeded, an error message is output by the device. Consequently, the device starts monitoring. The red ERROR-LED lights up.

Device-Specific Limits

Description	Limit	Comment
Maximum number of synchronous changes of chart inputs per task level	165	When the limit is exceeded, an error message is output by the device. Consequently, the device starts monitoring. The red ERROR-LED lights up.
Maximum number of chart outputs per task level	150	

Additional Limits

Additional limits ¹⁾ for the following CFC blocks:		
Task Level	Maximum Number of Modules in the Task Levels	
	TIMER ^{2) 3)}	TIMER_SHORT ^{2) 3)}
MW_BEARB	—	—
PLC1_BEARB	15	30
PLC_BEARB		
SFS_BEARB	—	—

- 1) When the limit is exceeded, an error message is issued by the device. Consequently, the device starts monitoring. The red ERROR-LED lights up.
- 2) The following condition applies for the maximum number of timers: $(2 \cdot \text{number of TIMER} + \text{number of TIMER_SHORT}) < 30$. TIMER and TIMER_SHORT hence share the available timer resources within the frame of this inequation. The limit does not apply to the LONG_TIMER.
- 3) The time values for the blocks TIMER and TIMER_SHORT must not be selected shorter than the time resolution of the device of 10 ms, as then, the blocks will not then start with the starting pulse.

Maximum Number of TICKS in the Task Levels

Task level	Limit in TICKS ¹⁾
MW_BEARB (measured value processing)	10000
PLC1_BEARB (slow PLC processing)	12000
PLC_BEARB (fast PLC processing)	600
SFS_BEARB (interlocking)	10000

¹⁾ When the sum of TICKS of all blocks exceeds the limits mentioned before, an error message is output in the CFC.

Processing Times in TICKS for the Individual Elements

Individual element		Number of TICKS
Block, basic requirement		5
Each input from the 3rd additional input on for generic modules		1
Combination with input signal border		6
Combination with output signal border		7
Additionally for each chart		1
Arithmetic	ABS_VALUE	5
	ADD	26
	SUB	26
	MUL	26
	DIV	54
	SQUARE_ROOT	83
Base logic	AND	5
	CONNECT	4
	DYN_OR	6
	NAND	5
	NEG	4
	NOR	5
	OR	5
	RISE_DETECT	4
X_OR	5	
Information status	SI_GET_STATUS	5
	CV_GET_STATUS	5
	DI_GET_STATUS	5
	MV_GET_STATUS	5
	SI_SET_STATUS	5
	DI_SET_STATUS	5
	MV_SET_STATUS	5
	ST_AND	5
	ST_OR	5
ST_NOT	5	

	Individual element	Number of TICKS
Memory	D_FF	5
	D_FF_MEMO	6
	RS_FF	4
	RS_FF_MEMO	4
	SR_FF	4
	SR_FF_MEMO	4
Control commands	BOOL_TO_CO	5
	BOOL_TO_IC	5
	CMD_INF	4
	CMD_INF_EXE	4
	CMD_CHAIN	34
	CMD_CANCEL	3
	LOOP	8
Type converter	BOOL_TO_DI	5
	BUILD_DI	5
	DI_TO_BOOL	5
	DM_DECODE	8
	DINT_TO_REAL	5
	DIST_DECODE	8
	UINT_TO_REAL	5
	REAL_TO_DINT	10
	REAL_TO_UINT	10
Comparison	COMPARE	12
	LOWER_SETPOINT	5
	UPPER_SETPOINT	5
	LIVE_ZERO	5
	ZERO_POINT	5
Metered value (counter)	COUNTER	6
Time and clock pulse	TIMER	5
	TIMER_LONG	5
	TIMER_SHORT	8
	ALARM	21
	BLINK	11
Other	IO_UNIT	17

Routeable in Matrix

In addition to the defined preassignments, indications and measured values can be freely routed to buffers, preconfigurations can be removed.

4.23 Additional Functions

Operational Measured Values

Currents I_A, I_B, I_C Positive sequence component I_1 Negative sequence component I_2 I_N or $3I_0$	in A (kA) primary and in A secondary or in % of I_{Nom}
Range Tolerance ¹⁾	10 % to 150 % I_{Nom} 1.5 % of measured value, or 1 % I_{Nom} and between 151 % and 200 % I_{Nom} 3 % of measured value
Voltages (phase-to-ground) $V_{A-N}, V_{B-N}, V_{C-N}$ Voltages (phase-to-phase) $V_{A-B}, V_{B-C}, V_{C-A}, V_{SYN}$ V_N, V_{ph-N}, V_x or V_0 Positive sequence component V_1 Negative sequence component V_2	in kV primary, in V secondary or in % of V_{Nom}
Range Tolerance ¹⁾	10 % to 120 % of V_{Nom} 1.5 % of measured value, or 0.5 % of V_{Nom}
S, apparent power	in kVAR (MVAR or GVAR) primary and in % of S_{Nom}
Range Tolerance ¹⁾	0 % to 120 % of S_{Nom} 1.5 % of S_{Nom} for V/V_{Nom} and $I/I_{Nom} = 50$ to 120%
P, active power	with sign, total and phase-segregated in kW (MW or GW) primary and in % S_{Nom}
Range Tolerance ¹⁾	0 % to 120 % of S_{Nom} 2 % of S_{Nom} for V/V_{Nom} and $I/I_{Nom} = 50$ to 120% and $ \cos \varphi = 0.707$ to 1 with $S_{Nom} = \sqrt{3} \cdot V_{Nom} \cdot I_{Nom}$
Q, reactive power	with sign, total and phase-segregated in kVAR (MVAR or GVAR) primary and in % of S_{Nom}
Range Tolerance ¹⁾	0 % to 120 % of S_{Nom} 2 % of S_{Nom} for V/V_{Nom} and $I/I_{Nom} = 50$ to 120% and $ \sin \varphi = 0.707$ to 1 with $S_{Nom} = \sqrt{3} \cdot V_{Nom} \cdot I_{Nom}$
$\cos \varphi$, power factor ²⁾	total and phase-segregated
Range Tolerance ¹⁾	-1 to +1 2 % for $ \cos \varphi \geq 0.707$
Angle $\varphi_A, \varphi_B, \varphi_C$,	in degrees (°)
Range Tolerance ¹⁾	0 to 180° 0,5°
Frequency f	in Hz
Range Tolerance ¹⁾	$f_N \pm 5$ Hz 20 mHz
Temperature overload protection Θ / Θ_{Trip}	in %
Range Tolerance ¹⁾	0 % to 400 % 5 % class accuracy in acc. with IEC 60255-8
Currents of sensitive ground fault detection (total, active, and reactive current) $I_{Ns}, I_{Ns \text{ active}}, I_{Ns \text{ reactive}}$	in A (kA) primary and in mA secondary

Range	0 mA to 1600 mA or 0 A to 8 A for $I_{Nom} = 5 A$
Tolerance ¹⁾	3 % of measured value or 1 mA
Synchrocheck function	see section (Synchrocheck)

- 1) at nominal frequency
- 2) Displaying of $\cos \varphi$ as of I/I_{Nom} and V/V_{Nom} greater than 10%

Long-Term Mean Values

Time Window	5, 15, 30 or 60 minutes
Frequency of Updates	adjustable
Long-Term Averages	
of Currents of Real Power of Reactive Power of Apparent Power	$I_{Admd}; I_{Bdmd}; I_{Cdmd}; I_{1dmd}$ in A (kA) P_{dmd} in W (kW, MW) Q_{dmd} in VAR (kVAR, MVAR) S_{dmd} in VAR (kVAR, MVAR)

Min./Max. Memory

Storage of Measured Values	with date and time
Reset automatic	Time of day adjustable (in minutes, 0 to 1439 min) Time frame and starting time adjustable (in days, 1 to 365 days, and ∞)
Manual Reset	Using binary input Using keypad Via communication
Min/Max Values for Current	$I_A; I_B; I_C;$ I_1 (positive sequence component)
Min/Max Values for Voltages	$V_{A-N}; V_{B-N}; V_{C-N};$ V_1 (Positive Sequence Component); $V_{A-B}; V_{B-C}; V_{C-A}$
Min/Max Values for Power	S, P; Q, $\cos \varphi$; frequency
Min/Max Values for Overload Protection	Θ/Θ_{Trip}
Min/Max Values for Mean Values	$I_{Admd}; I_{Bdmd}; I_{Cdmd};$ I_1 (positive sequence component); $S_{dmd}; P_{dmd}; Q_{dmd}$

Fuse Failure Monitor

Setting range of the displacement voltage 3U0 above which voltage failure is detected	10 - 100 V
Setting range of the ground current above which no voltage failure is assumed	0.1 - 1 A for $I_{Bdmd} = 1 A$ 0.5 - 5A for $I_{Bdmd} = 5A$
Setting range of the pickup threshold I> above which no voltage failure is assumed	0.1 - 35 A for $I_{Bdmd} = 1 A$ 0.5 - 175 A for $I_{Bdmd} = 5A$
Measuring voltage monitoring	depends on the MLFB and configuration with measured and calculated values V_N and I_N

Broken-wire Monitoring of Voltage Transformer Circuits

suited for single-, two- or three-pole broken-wire detection of voltage transformer circuits;
only for connection of phase-Ground voltages

Local Measured Value Monitoring

Current asymmetry	$I_{\max}/I_{\min} > \text{symmetry factor, for } I > I_{\text{limit}}$
Voltage asymmetry	$V_{\max}/V_{\min} > \text{symmetry factor, for } V > V_{\text{limit}}$
Current sum	$ i_A + i_B + i_C + k_I \cdot i_N > \text{limit value, with}$ $k_I = \frac{I_{\text{gnd-CT PRIM}} / I_{\text{gnd-CT SEC}}}{CT \text{ PRIMARY} / CT \text{ SECONDARY}}$
Current phase sequence	Clockwise (ABC) / counter-clockwise (ACB)
Voltage phase sequence	Clockwise (ABC) / counter-clockwise (ACB)

Fault Logging

Recording of indications of the last 8 power system faults
Recording of indications of the last 3 power system ground faults

Time Allocation

Resolution for Event Log (Operational Annunciations)	1 ms
Resolution for Trip Log (Fault Annunciations)	1 ms
Maximum Time Deviation (Internal Clock)	0.01 %
Battery	Lithium battery 3 V/1 Ah, type CR 1/2 AA Message „Battery Fault“ for insufficient battery charge

Fault Recording

maximum of 8 fault records saved; memory maintained by buffer battery in the case of auxiliary voltage failure	
Recording time	5 s per fault record, in total up to 18 s at 50 Hz (max. 15 s at 60 Hz)
Intervals at 50 Hz Intervals at 60 Hz	1 instantaneous value each per 1.0 ms 1 instantaneous value each per 0.83 ms

Energy Counter

Meter Values for Energy Wp, Wq (real and reactive energy)	in kWh (MWh or GWh) and in kVARh (MVARh or GVARh)
Range	28 bit or 0 to 2 68 435 455 decimal for IEC 60870-5-103 (VDEW protocol) 31 bit or 0 to 2 147 483 647 decimal for other protocols (other than VDEW) $\leq 2\%$ for $I > 0.1 I_{\text{Nom}}$, $V > 0.1 V_{\text{Nom}}$ and $ \cos \varphi \geq 0.707$
Tolerance ¹⁾	

¹⁾ At nominal frequency

Switching Statistics

Saved Number of Trips	Up to 9 digits
Number of Automatic Reclosing Commands (segregated according to 1st and ≥ 2nd cycle)	Up to 9 digits
Accumulated Interrupted Current (segregated according to pole)	Up to 4 digits

Operating Hours Counter

Display Range	Up to 7 digits
Criterion	Overshoot of an adjustable current threshold (element 50-1, BkrClosed I MIN)

Circuit Breaker Monitoring

Calculation method	on r.m.s. value basis: ΣI , ΣI^x , 2P; on instantaneous value basis: I^2t
Measured value acquisition/processing	phase-selective
Evaluation	one limit value each per subfunction
Saved number of statistical values	up to 13 decimal places

Trip Circuit Supervision

With one or two binary inputs.

Commissioning Aids

- Phase rotation test
- Operational measured values
- Circuit breaker test by means of control function
- Creation of a test fault report
- Creation of messages

Clock

Time synchronization		Binary input Communication
Modes of operation for time tracking		
No.	Mode of operation	Explanations
1	Internal	Internal synchronization using RTC (presetting)
2	IEC 60870-5-103	External synchronization using port B (IEC 60870-5-103)
3	Pulse via binary input	External synchronization with pulse via binary input
4	Fieldbus (DNP (serial or DNP3 TCIP, Modbus, IEC 60870-5-103 redundant)	External synchronization using field bus
5	SNTP (IEC 61850, DNP3 TCP, PROFINET IO)	External synchronization using port B (IEC 61850)
-	SNTP (no IEC61850)	External synchronization via port A Parameterization via device; notes under 2.1.2.2

Group Switchover of the Function Parameters

Number of available setting groups	4 (parameter group A, B, C and D)
Switchover can be performed via	the keypad on the device DIGSI using the operator interface protocol using port B binary input

IEC 61850 GOOSE (Inter-Relay Communication)

The GOOSE communication service of IEC 61850 is qualified for switchgear interlocking. Since the transmission time of GOOSE messages depends on both the number of IEC 61850 clients and the relay's pickup condition, GOOSE is not generally qualified for protection-relevant applications. The protective application is to be checked with regard to the required transmission time and cleared with the manufacturer.

4.24 Switching Device Control

Number of Controlled Switching Devices	Depends on the number of binary inputs and outputs available
Interlocking	Freely programmable interlocking
Messages	Feedback messages; closed, open, intermediate position
Control Commands	Single command / double command
Switching Command to Circuit Breaker	1-, 1½ - and 2-pole
Programmable Logic Controller	PLC logic, graphic input tool
Local Control	Control via menu control assignment of function keys
Remote Control	Using Communication Interfaces Using a substation automation and control system (e.g. SICAM) Using DIGSI (e.g. via Modem)

4.25 Dimensions

4.25.1 Panel Flush and Cubicle Mounting (Housing Size 1/6)

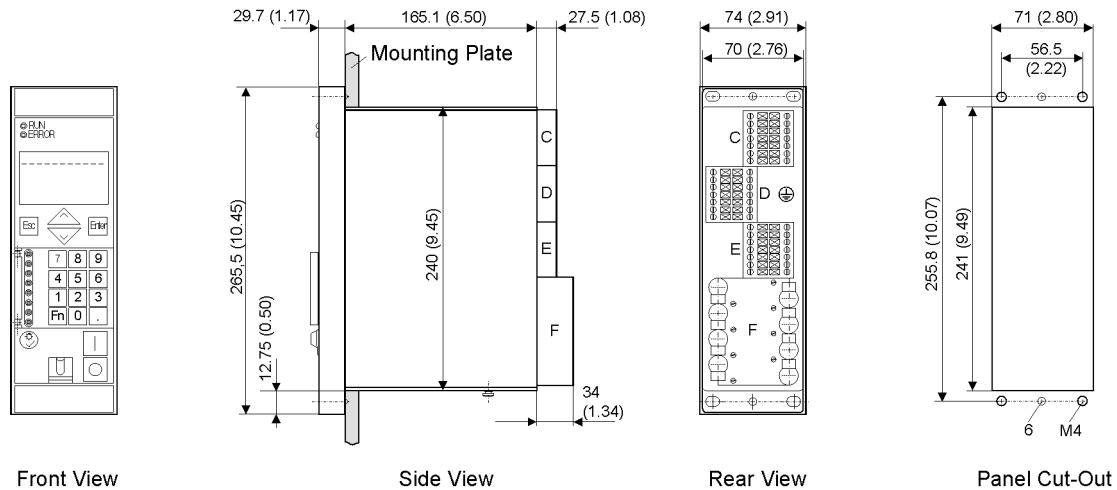

Figure 4-11 Dimensional drawing of a 7SJ80 for panel flush or cubicle mounting (housing size $\frac{1}{6}$)

Note: A set of mounting brackets (consisting of upper and lower mounting rail) (order no. C73165-A63-D200-1) is required for cubicle mounting. When using the Ethernet interface, it may be necessary to rework the lower mounting rail.

Provide for sufficient space at the device bottom side or below the device to accommodate the cables of the communication modules.

4.25.2 Panel Surface Mounting (Housing Size 1/6)

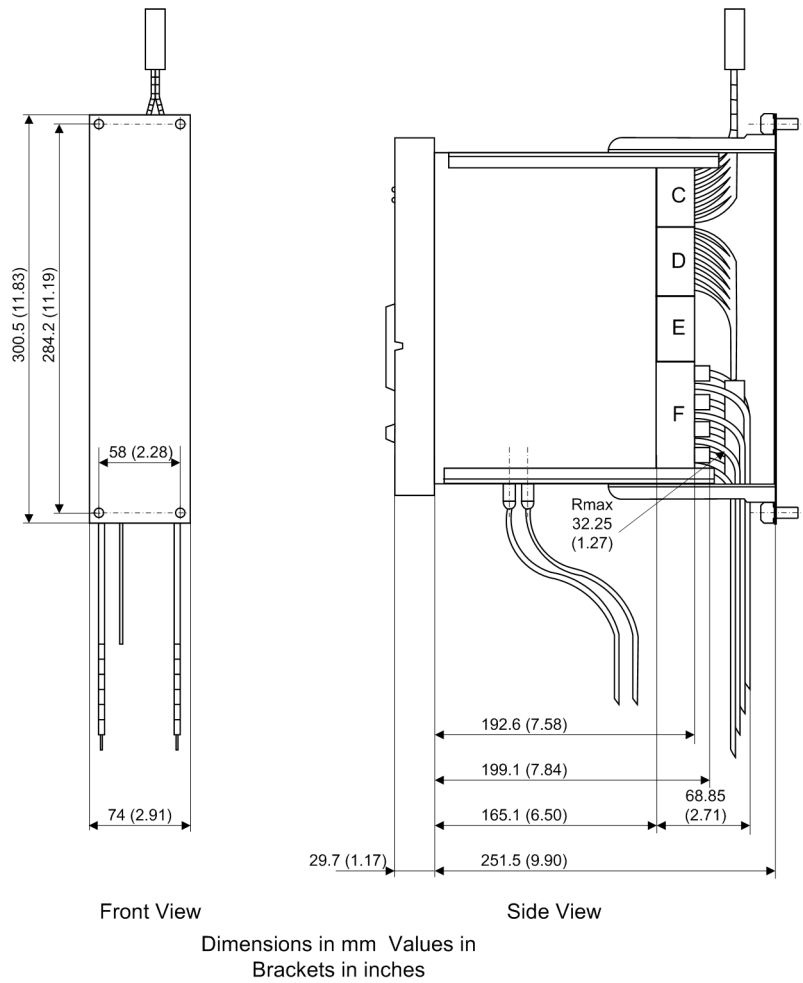

Figure 4-12 Dimensional drawing of a 7SJ80 for panel surface mounting (housing size 1/6)

4.25.3 Bottom view

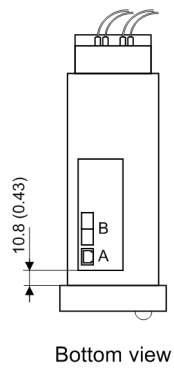
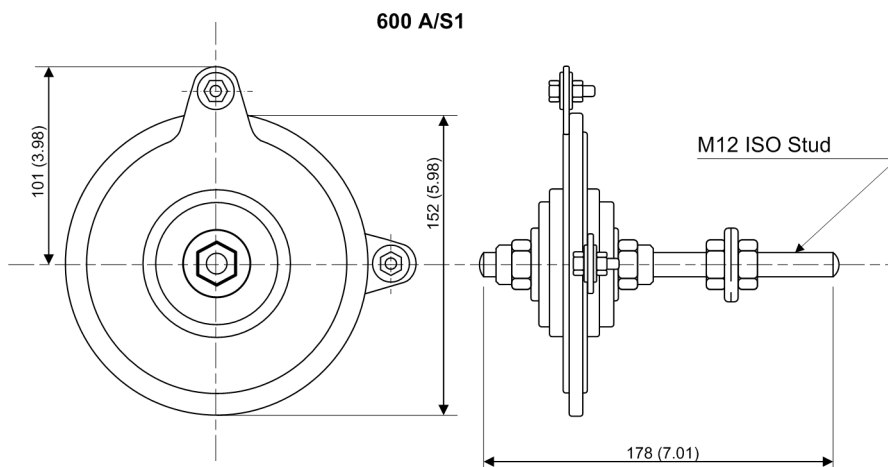

Figure 4-13 Bottom view of a 7SJ80 (housing size 1/6)

4.25.4 Varistor



Dimensions in mm Values in Brackets in inches

Figure 4-14 Dimensional drawing of the varistor for voltage limiting in high-impedance differential protection



Appendix

A

This appendix is primarily a reference for the experienced user. This section provides ordering information for the models of this device. Connection diagrams indicating the terminal connections of the models of this device are included. Following the general diagrams are diagrams that show the proper connections of the devices to primary equipment in many typical power system configurations. Tables with all settings and all information available in this device equipped with all options are provided. Default settings are also given.

A.1	Ordering Information and Accessories	476
A.2	Terminal Assignments	482
A.3	Connection Examples	488
A.4	Current Transformer Requirements	502
A.5	Default Settings	505
A.6	Protocol-dependent Functions	511
A.7	Functional Scope	512
A.8	Settings	516
A.9	Information List	537
A.10	Group Alarms	560
A.11	Measured Values	563

A.1 Ordering Information and Accessories

A.1.1 Ordering Information

A.1.1.1 7SJ80 V4.7

Multifunctional protection device with control	6	7	8	9	10	11	12	13	14	15	16	Supplementary			
	7	S	J	8	0	<input type="text"/>	<input type="text"/>	-	<input type="text"/>	<input type="text"/>	<input type="text"/>		<input type="text"/>	+	<input type="text"/>

Number of binary inputs and outputs	Pos. 6
Housing 1/6 19" 4 x I, 3 BI, 5 BO (2 changeover contacts), 1 life status contact	1
Housing 1/6 19" 4 x I, 7 BI, 8 BO (2 changeover contacts), 1 life status contact	2
Housing 1/6 19" 4 x I, 3x V, 3 BI, 5 BO (2 changeover contacts), 1 life status contact	3
Housing 1/6 19" 4 x I, 3 x V, 7 BI, 8 BO (2 changeover contacts), 1 life status contact	4
Housing 1/6 19" 4 x I, 11 BI, 5 BO (2 changeover contacts), 1 life contact	7
Housing 1/6 19" 4 x I, 3 x V, 11 BI, 5 BO (2 changeover contacts), 1 life contact	8

Measuring inputs (4 x I)	Pos. 7
$I_{ph} = 1 A, I_n = 1 A / 5 A$	1
$I_{ph} = 1 A, I_{ns} \text{ (sensitive)} = 0.001 \text{ to } 1.6 A / 0.005 \text{ to } 8 A$	2

Auxiliary voltage (power supply, pilot voltage)	Pos. 8
DC 24 V/48 V	1
DC 60 V / 110 V / 125 V / 220 V / 250 V, AC 115 V, AC 230 V	5

Construction	Pos. 9
Surface-mounting case, screw-type terminals	B
Flush mounting case, screw-type terminals	E

Region-specific default settings / function versions and language default settings	Pos. 10
Region DE, IEC, language German (language can be changed, standard front panel	A
Region world, IEC/ANSI, language English (language can be changed), standard front panel	B
Region US, ANSI, language US-English (language can be changed), US front panel	C
Region FR, IEC/ANSI, language French (language can be changed), standard front panel	D
Region world, IEC/ANSI, language Spanish (language can be changed), standard front panel	E
Region world, IEC/ANSI, language Italian (language can be changed), standard front panel	F
Region RUS, IEC/ANSI, language Russian (language can be changed), standard front panel	G
Region CHN, IEC/ANSI, language Chinese (language can not be changed), standard front panel Chinese	K

Port B (bottom side of device, rear)	Pos. 11
not equipped	0
IEC60870-5-103 or DIGSI4/Modem, electrical RS232	1
IEC60870-5-103 or DIGSI4/Modem, electrical RS485	2
IEC60870-5-103 or DIGSI4/Modem, optical 820nm, ST connector	3
For further interface options see Additional Information in the following	9

Additional information for additional ports (bottom side of device, rear, port B)	Supplementary
Profibus DP Slave, electrical RS485	+ L 0 A
Profibus DP Slave, 820 nm, optical double ring, ST connector	+ L 0 B
Modbus, electrical RS485	+ L 0 D
Modbus, optical 820 nm, ST connector	+ L 0 E
DNP3.0, electrical RS485	+ L 0 G
DNP3.0, optical 820 nm, ST connector	+ L 0 H
IEC 60870-5-103 Protocol, redundant, electrical RS485, RJ45 connector	+ L 0 P
IEC 61850, 100Mbit Ethernet electrical, double, RJ45 connector	+ L 0 R
IEC 61850 100 Mbit Ethernet optical, double, LC connector	+ L 0 S
DNP3 TCP+ IEC 61850, 100 Mbit Ethernet electrical, double, RJ45 connector	+ L 2 R
DNP3 TCP+ IEC 61850, 100 Mbit Ethernet optical, double, LC connector	+ L 2 S
PROFINET+ IEC 61850 100Mbit Ethernet electrical, double, RJ45 connector	+ L 3 R
PROFINET+ IEC 61850 100 Mbit Ethernet optical, double, LC connector	+ L 3 S
IEC 60870-5-104 + IEC 61850, 100Mbit Ethernet, electrical, double, RJ45 connector	+ L 4 R
IEC 60870-5-104 + IEC 61850, 100Mbit Ethernet, optical, double, LC connector	+ L 4 S

Converter	Order number	Use
SIEMENS OLM ¹⁾	6GK1502-2CB10	for single ring
SIEMENS OLM ¹⁾	6GK1502-3CB10	for twin ring

¹⁾ The converter requires an operating voltage of 24 VDC. If the available operating voltage is > 24 VDC the additional power supply 7XV5810-0BA00 is required.

Port A (bottom side of device, front)	Pos. 12
not equipped	0
with Ethernet interface (DIGSI interface, I/O unit connection, not IEC61850), RJ45 connector	6

Measurement / Fault Recording	Pos. 13
With fault recording	1
With fault recording, average values, min/max values	3

Standard	Pos. 14
With Standard functions	F
With CEI 0-16 PI functions. (27/59/59V0/81/81V) ¹⁾	G

¹⁾ only deliverable with position 15 = B, C or F. Option G of Pos. 14 is chosen only when using Italian CEI 0-16 standard.

Functions			Pos. 15
Name	ANSI No.	Description	A
Basic function (included in all versions) ³⁾	—	Control	
	50/51	Time overcurrent protection phase 50-1, 50-2, 50-3, 51	
	50N/51N	Time overcurrent protection ground 50N-1, 50N-2, 50N-3, 51N	
	50N(s)/ 51N(s)	Ground fault protection/ ground short-circuit protection 50Ns-1, 50Ns-2, 51Ns ¹⁾	
	—	Intermittent ground fault protection	
	87N	High-impedance ground fault differential protection (87N (REF) only available with sensitive ground current input (position 7 = 2))	
	49	Thermal overload protection	
	74TC	Trip circuit supervision	
	46	Negative sequence overcurrent protection	
	50BF	Breaker failure protection 50BF	
	37	Undercurrent surveillance	
	86	Lock out	
	—	Cold-load pickup Monitoring functions Circuit breaker control Flexible protection functions (parameters from current) Inrush restraint	
Basic design ⁴⁾ + ground fault direction detection + voltage protection + frequency protection	51V	Voltage-controlled inverse-time overcurrent protection	B
	67N	Directional ground fault protection 67N-1, 67N-2, 67N-3, 67N-TOC	
	67N(s)	Directional ground fault protection/ground short circuit protection 67Ns-1, 67Ns-2, 67Ns-TOC ¹⁾	
	64/59N	Displacement voltage	
	27/59	Undervoltage / overvoltage	
	81 U/O	Underfrequency / overfrequency, f<, f>	
	47	Phase sequence	
	32/55/81R/ 27R/59R	Flexible protection functions (parameters from current and voltage): Voltage protection, power protection, power factor pro- tection, frequency change protection and voltage change protection	

Functions			Pos. 15
Basic design ⁴⁾ + ground fault direction detection + direction determination for phase + voltage protection + frequency protection	51V	Voltage-controlled inverse-time overcurrent protection	C
	67	Direction determination for overcurrent phases 67-1, 67-2, 67-3, 67-TOC	
	67N	Directional ground fault protection 67N-1, 67N-2, 67N-3, 67N-TOC	
	67N(s)	Directional ground fault protection/ground short circuit protection 67Ns-1, 67Ns-2, 67Ns-TOC ¹⁾	
	64/59N	Displacement voltage	
	27/59	Undervoltage / overvoltage	
	81 U/O	Underfrequency / overfrequency, f< ,f>	
	47	Phase sequence	
32/55/81R/ 27R/59R	Flexible protection functions (parameters from current and voltage): Voltage protection, power protection, power factor protection, frequency change protection and voltage change protection		
Basic design ⁴⁾ + ground fault direction detection + direction determination for phase + voltage protection + frequency protection + QU protection + directional intermittent ground fault protection	51V	Voltage-controlled inverse-time overcurrent protection	F
	67	Direction determination for overcurrent phases 67-1, 67-2, 67-3, 67-TOC	
	67N	Directional ground fault protection 67N-1, 67N-2, 67N-3, 67N-TOC	
	67N(s)	Directional ground fault protection/ground short circuit protection 67Ns-1, 67Ns-2, 67Ns-TOC ¹⁾	
	67Ns	Directional intermittent ground fault protection ²⁾	
	64/59N	Displacement voltage	
	27/59	Undervoltage / overvoltage	
	81 U/O	Underfrequency / overfrequency, f< ,f>	
	—	Undervoltage-controlled reactive power protection (Q>/U<)	
	47	Phase sequence	
32/55/81R2 7R/59R	Flexible protection functions (parameters from current and voltage): Voltage protection, power protection, power factor protection, frequency change protection and voltage change protection		
Basic design ⁵⁾ + direction determination for phase + voltage protection + frequency protection + synchrocheck	51V	Voltage-controlled inverse-time overcurrent protection	Q
	67	Direction determination for overcurrent phases 67-1, 67-2, 67-3, 67-TOC	
	27/59	Undervoltage / overvoltage	
	81 U/O	Underfrequency / overfrequency, f< ,f>	
	47	Phase sequence	
	25	Synchronism check	
	81R/27R/5 9R	Flexible protection functions (parameters from current and voltage): Voltage protection, frequency change protection and voltage change protection	

- 1) depending on the ground current input at position 7, the function works either as ground fault protection (sensitive input) or as ground short circuit protection (normal Ie input)
- 2) only with sensitive input, Position 7=2
- 3) only deliverable with position 6 = 1, 2 or 7
- 4) only deliverable with position 6 = 3, 4 (3 x V) or 8
- 5) only deliverable with position 6 = 3, 4 (3 x V) or 8 and position 16 = 0 or 1

Automatic reclosing function 79AR / Fault locator 21FL			Pos. 16
		No 79, no fault locator	0
	79	With 79	1
	21FL	With fault locator ¹⁾	2
	79, 21FL	With AR, with fault locator ¹⁾	3

- 1) only deliverable with position 6 = 1, 2 or 7

A.1.2 Accessories

Exchangeable interface modules

Name	Order No.
RS232	C53207-A351-D641-1
RS485	C53207-A351-D642-1
FO 820 nm	C53207-A351-D643-1
Profibus DP RS485	C53207-A351-D611-1
Profibus DP double ring	C53207-A351-D613-1
Modbus RS485	C53207-A351-D621-1
Modbus 820 nm	C53207-A351-D623-1
DNP 3.0 RS 485	C53207-A351-D631-1
DNP 3.0 820 nm	C53207-A351-D633-1
Ethernet electrical (EN 100)	C53207-A351-D675-2
Ethernet optical (EN 100), 4 ST connectors	C53207-A351-D676-1
Ethernet electrical (EN 100, PROFINET IO)	C53207-A351-D688-1
Ethernet optical (EN 100, PROFINET IO)	C53207-A351-D689-1
Ethernet electrical (EN 100, DNP3 TCP)	C53207-A351-D684-1
Ethernet optical (EN 100, DNP3 TCP), multimode	C53207-A351-D686-1
IEC 60870-5-103 protocol, redundant, RS485	C53207-A351-D644-1
Ethernet port electrical at port A	C53207-A351-D151-1

RS485 FO converter

RS485 FO converter	Order No.
820 nm; FC-Connector	7XV5650-0AA00
820 nm, with ST-Connector	7XV5650-0BA00

Mounting Rail for 19"-Racks

Name	Order Number
Mounting Rail Set	C73165-A63-D200-1

Surface mounting console (converts flush mounting variants into surface mounting variant)

Surface mounting console	C53207-A356-D850-1
--------------------------	--------------------

Battery

Lithium battery 3 V/1 Ah, type CR 1/2 AA	Order No.
VARTA	6127 101,301
Panasonic	BR-1/2AA

Terminals

Voltage terminal block C or block E	C53207-A406-D181-1
Voltage terminal block D (inverse print)	C53207-A406-D182-1
Current terminal block 4xl	C53207-A406-D185-1
Current terminal block 3xl,1xINs (sensitive)	C53207-A406-D186-1
Current terminal short circuit links, 3 pieces	C53207-A406-D193-1
Voltage terminal short circuit links, 6 pieces	C53207-A406-D194-1

Varistor

Voltage-limiting resistor for high-impedance differential protection	
Name	Order number
125 Veff, 600 A, 1S/S256	W73028-V3125-A1
240 Veff, 600 A, 1S/S1088	W73028-V3300-A2

A.2 Terminal Assignments

A.2.1 7SJ80 — Housing for panel flush mounting and cubicle installation and for panel surface mounting

7SJ801*

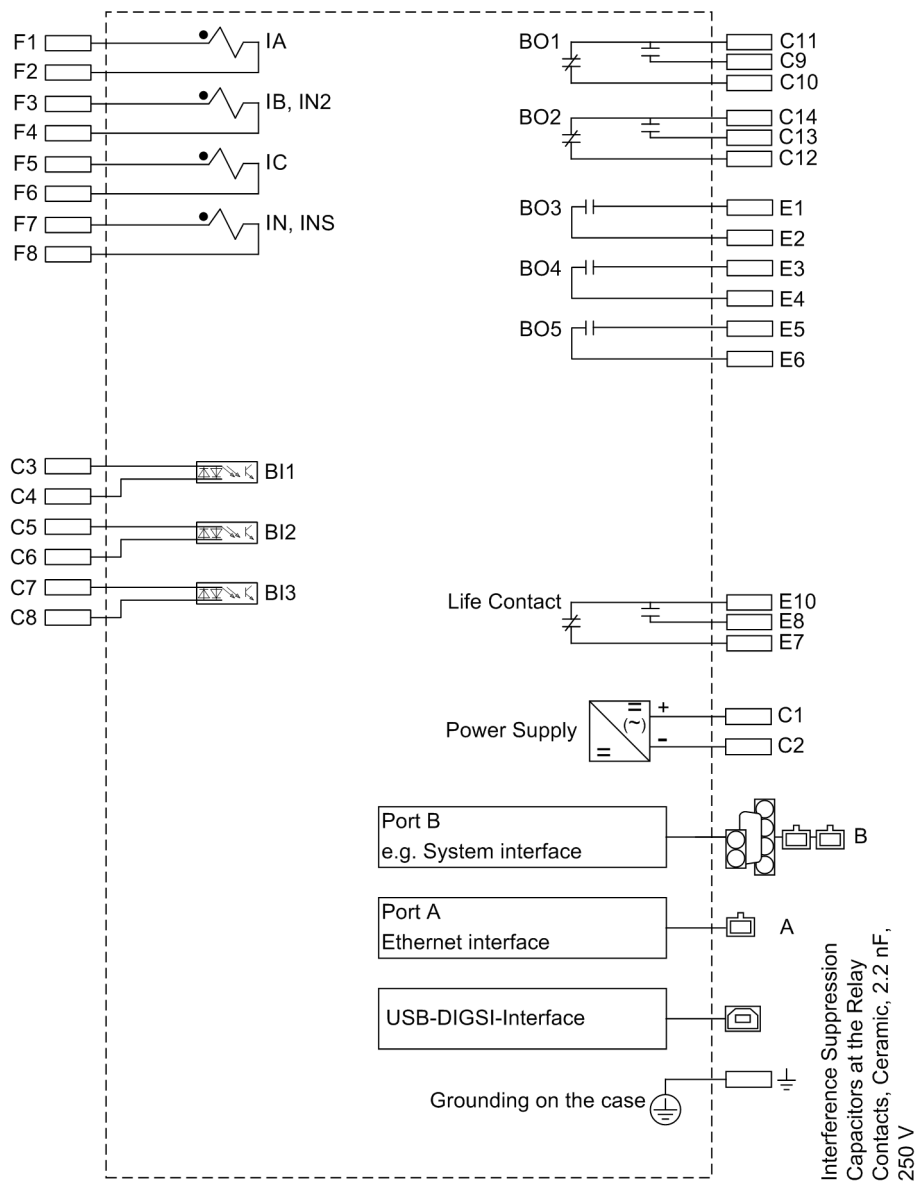
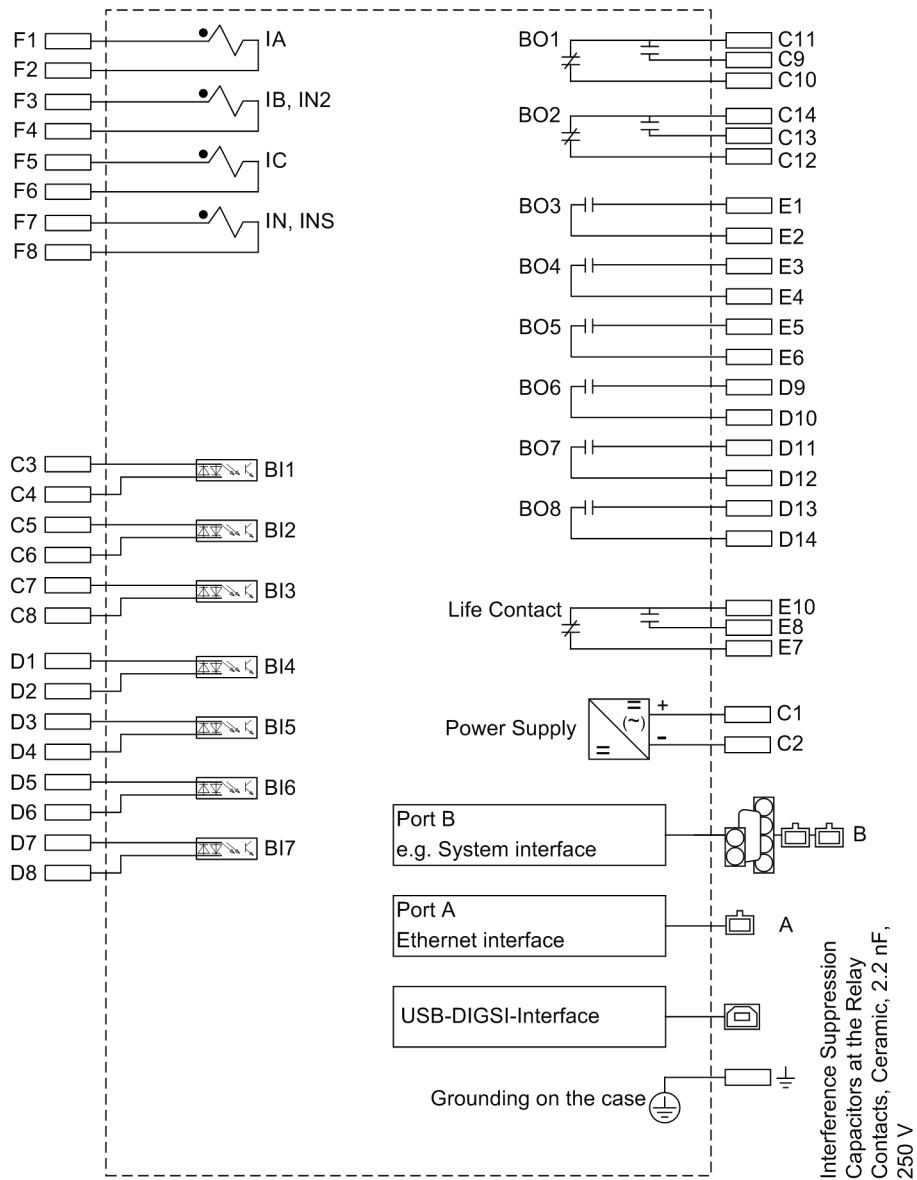

Figure A-1 Block diagram 7SJ801*

7SJ802*



7SJ803*

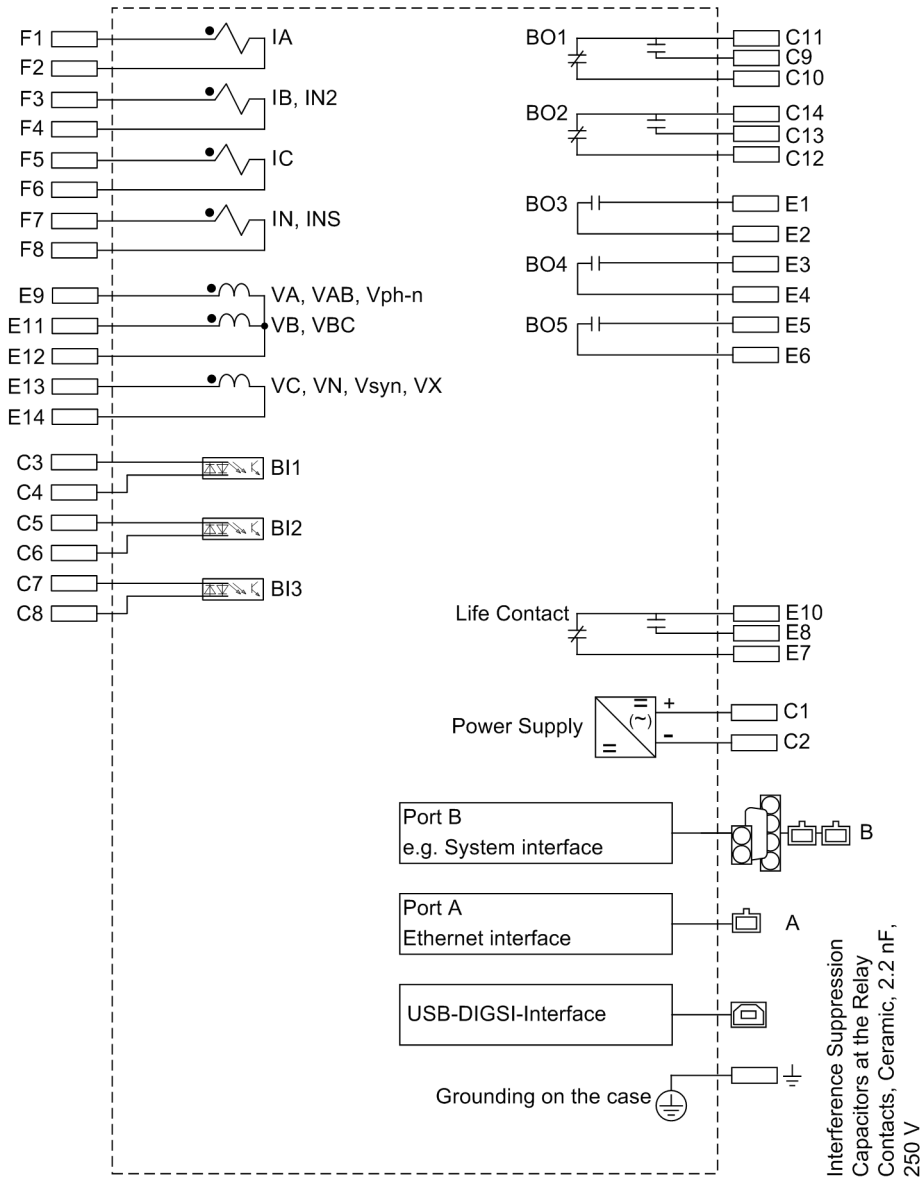

Figure A-3 Block diagram 7SJ803*

7SJ804*

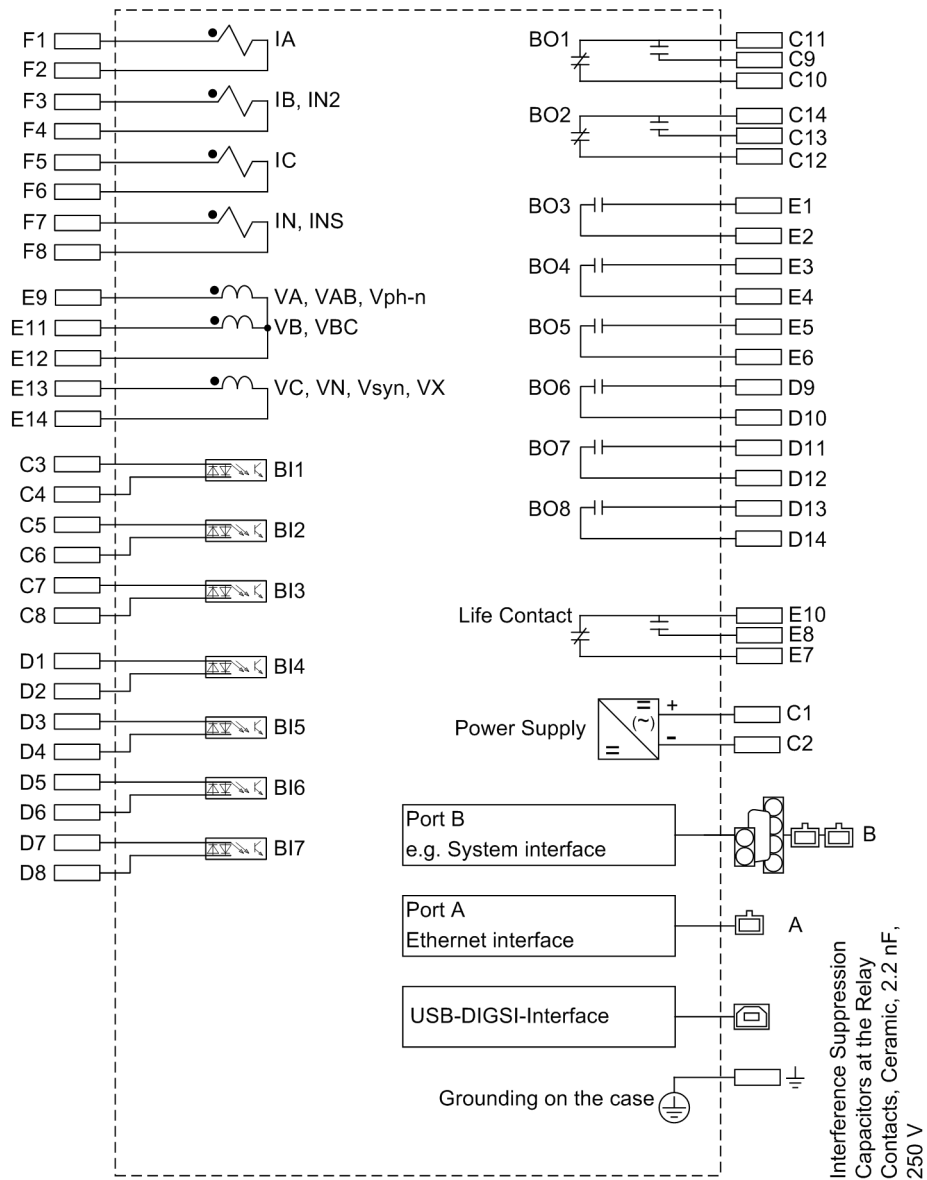

Figure A-4 Block diagram 7SJ804*

7SJ807*

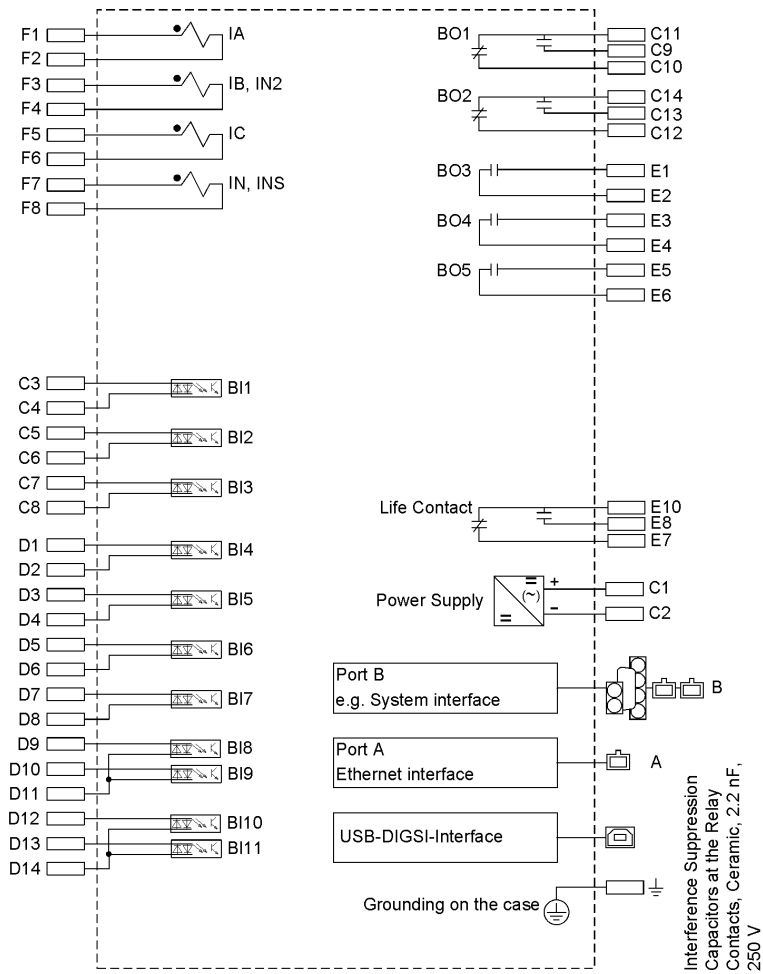

Figure A-5 Connection diagram 7SJ807*

*) The shield of the connecting cable is connected directly to the shield cover.

7SJ808*

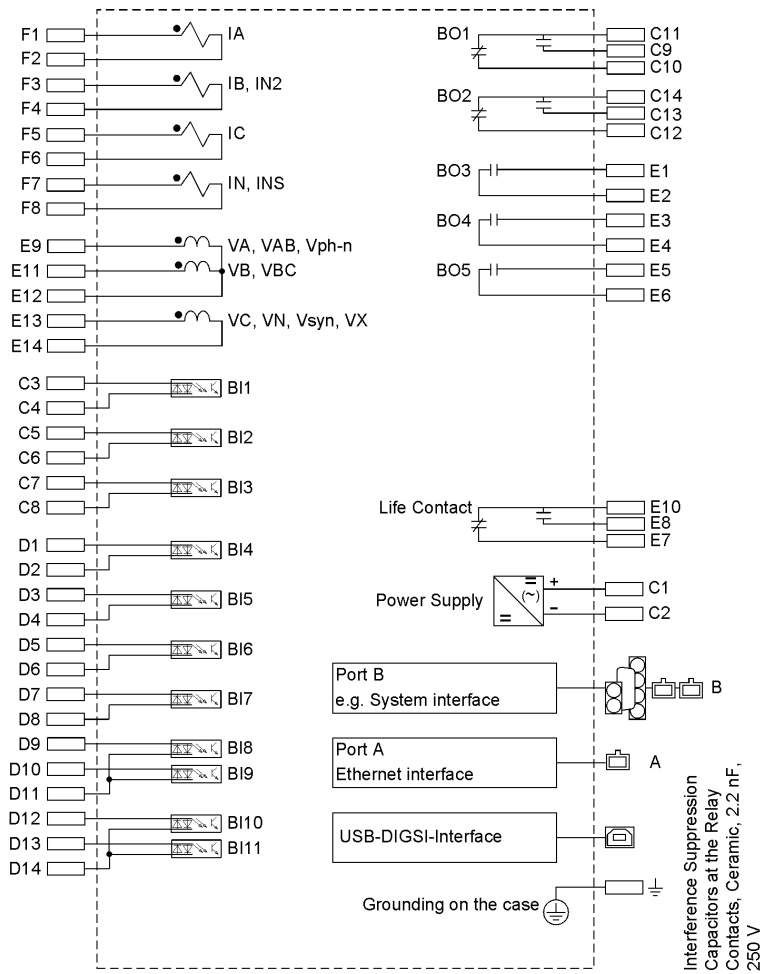

Figure A-6 Connection diagram 7SJ808*

*) The shield of the connecting cable is connected directly to the shield cover.

A.3 Connection Examples

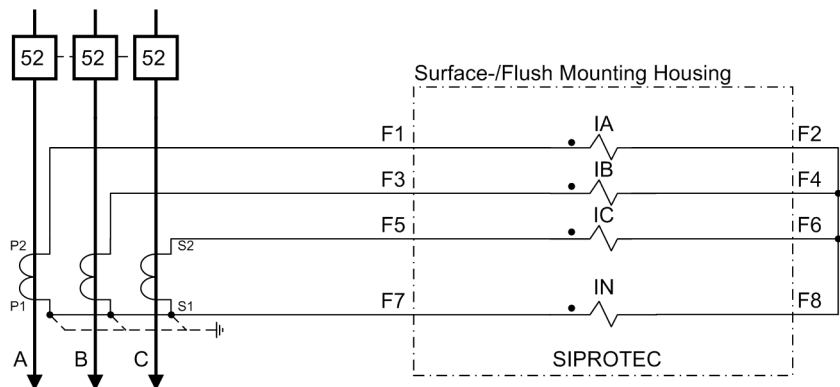

Figure A-7 Current transformer connections to three current transformers and neutral point current (ground current) (Holmgreen connection) – appropriate for all networks

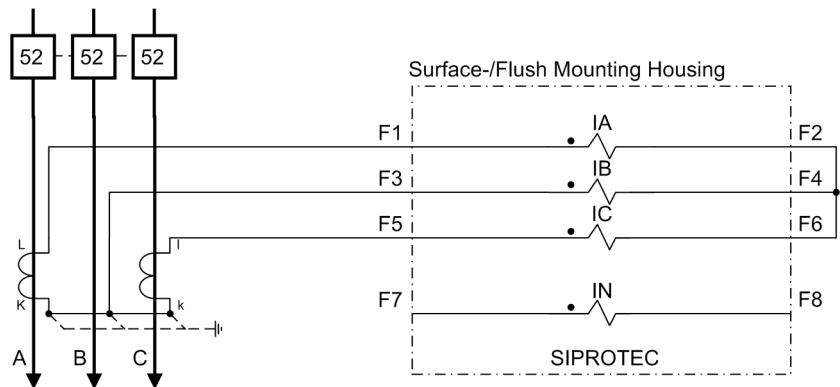

Figure A-8 Current transformer connections to two current transformers – only for isolated or resonant-grounded networks

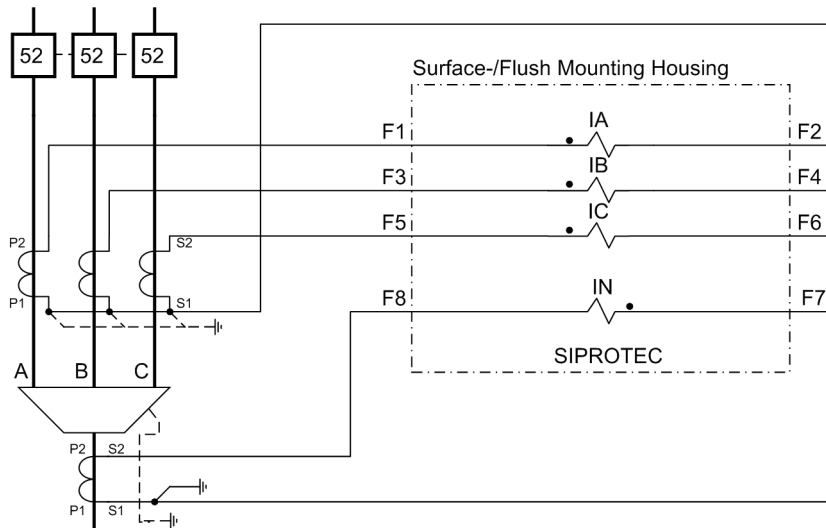

Figure A-9 Current transformer connections to three current transformers, ground current from additional summation current transformer – preferably for effectively or low-resistance grounded networks

Important: Grounding of the cable shield must be effected at the cable side

Note: The switchover of the current polarity (address 201) also reverses the polarity of the current input IN!

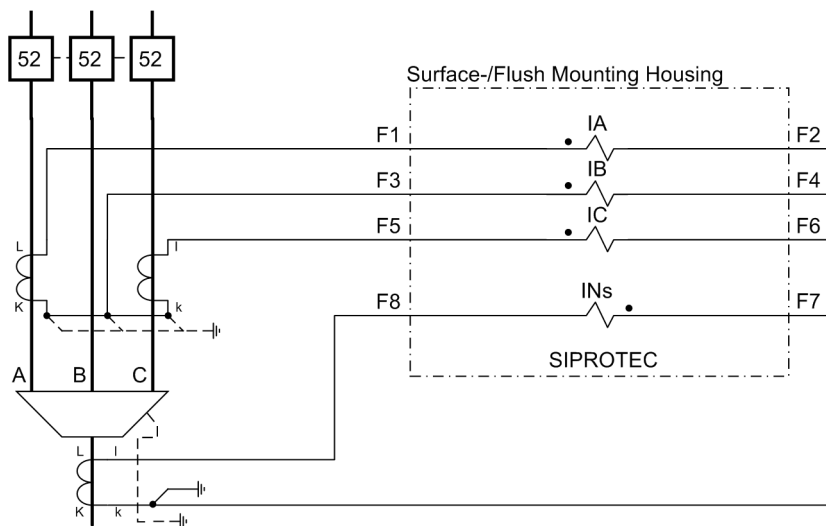

Figure A-10 Current transformer connections to two current transformers - additional cable-type current transformer for sensitive ground fault detection - only for isolated or resonant-grounded networks

Important: Grounding of the cable shield must be effected at the cable side

Note: The switchover of the current polarity (address 201) also reverses the polarity of the current input INs!

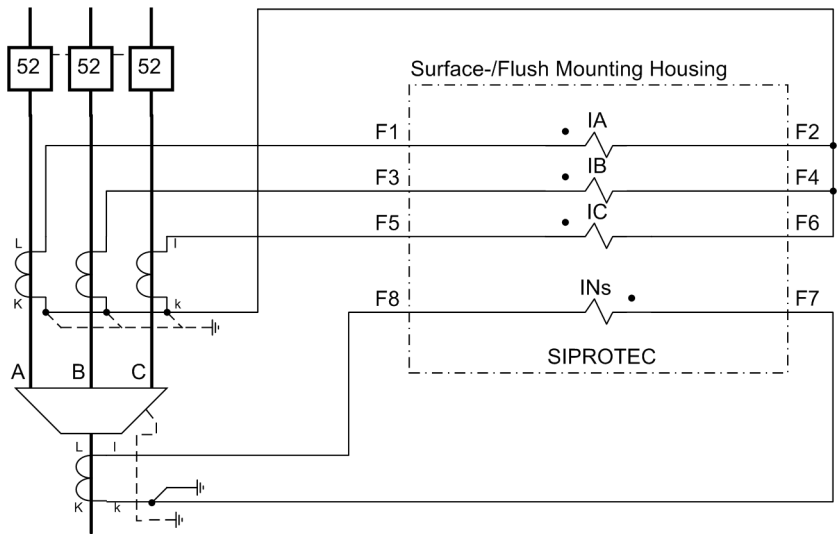

Figure A-11 Current transformer connections to three current transformers - ground current from additional cable-type current transformer for sensitive ground fault detection

Important: Grounding of the cable shield must be effected at the cable side

Note: The switchover of the current polarity (address 201) also reverses the polarity of the current input INs!

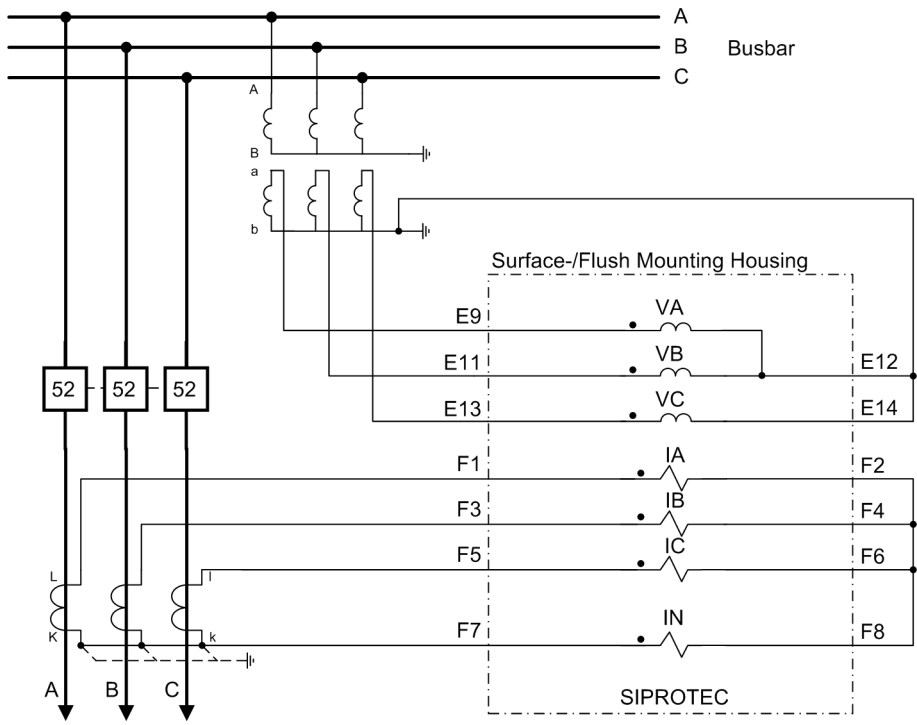

Figure A-12 Transformer connections to three current transformers and three voltage transformers (phase-to-ground voltages), normal circuit layout – appropriate for all networks

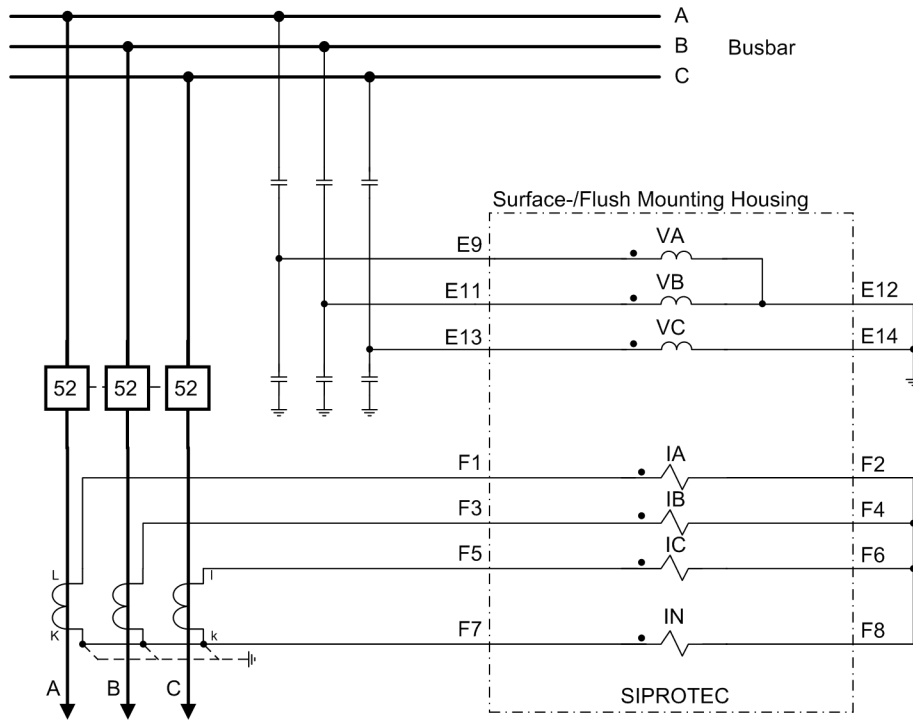

Figure A-13 Transformer connections to three current transformers and three voltage transformers - capacitive -

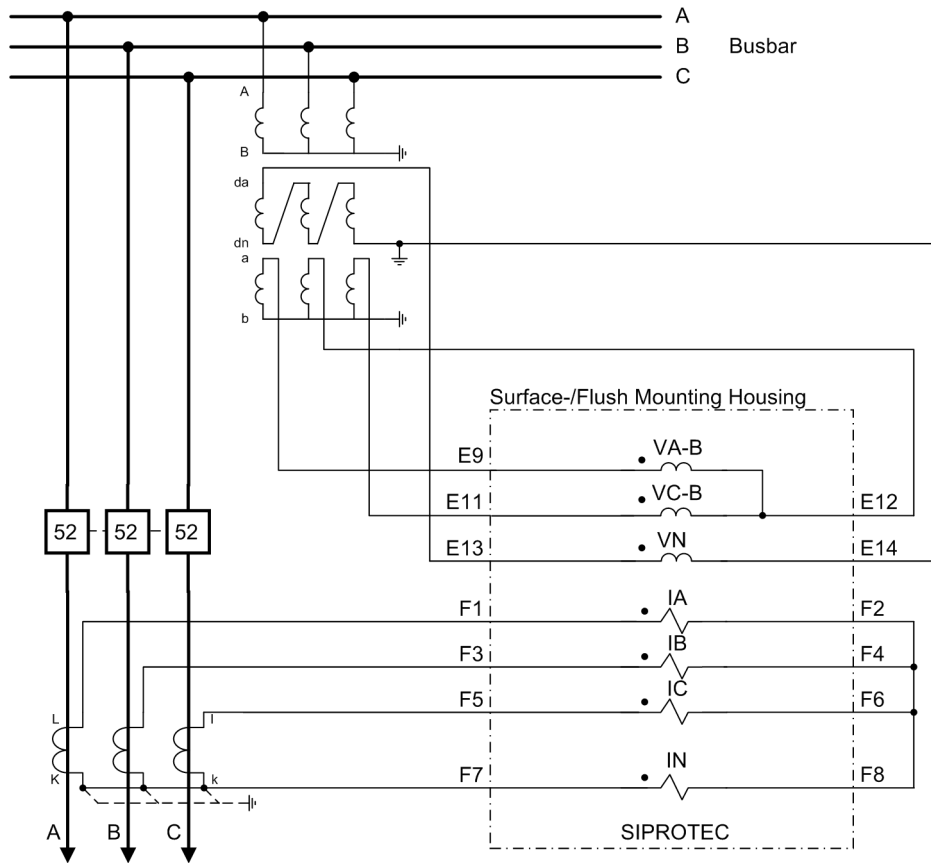

Figure A-14 Transformer connections to three current transformers, two voltage transformers (phase-to-phase voltages) and broken delta winding (da-dn) – appropriate for all networks

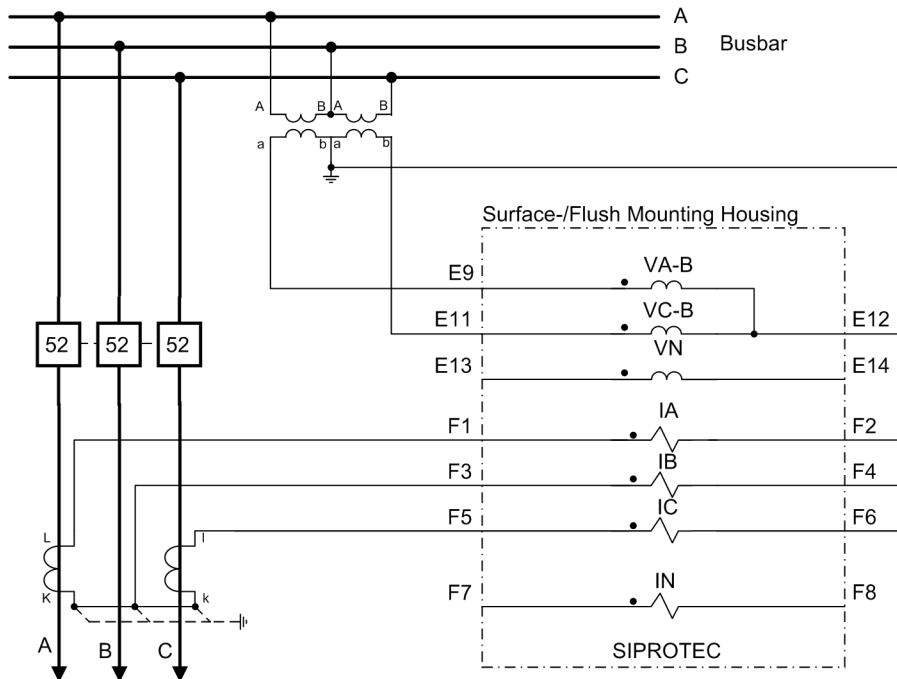

Figure A-15 Current transformer connections to two current transformers and as open-delta connection the voltage transformer – for isolated or resonant-grounded networks when no directional ground protection is needed

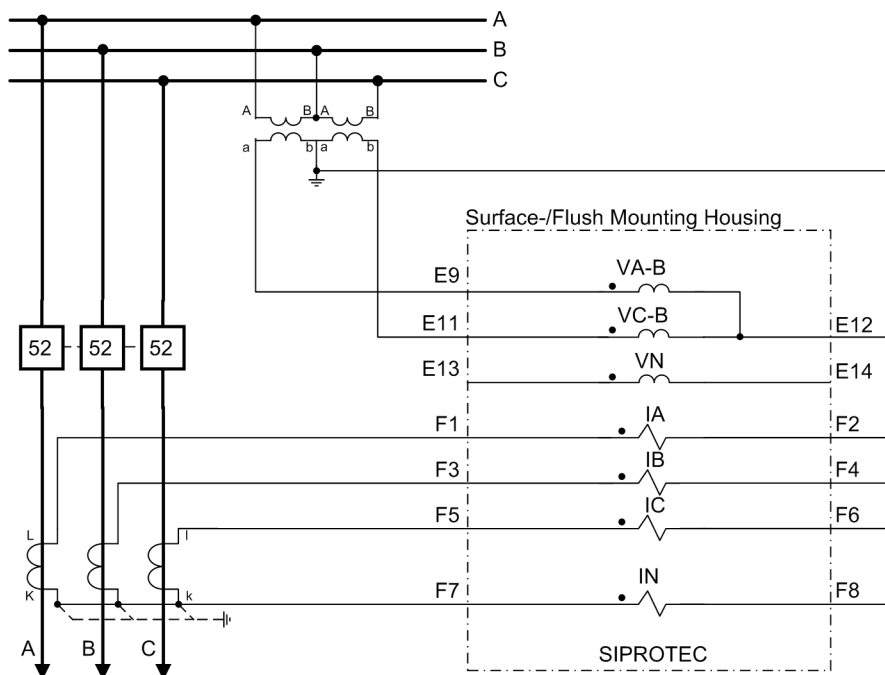

Figure A-16 Current transformer connections to three current transformers, two voltage transformers in open-delta connection, only for isolated or resonant-grounded networks; no directional ground protection since displacement voltage cannot be calculated

Hint If the system has only 2 voltage transformers (open-delta connection), the device, too, should be connected in open-delta connection and the unused voltage input should be short-circuited.

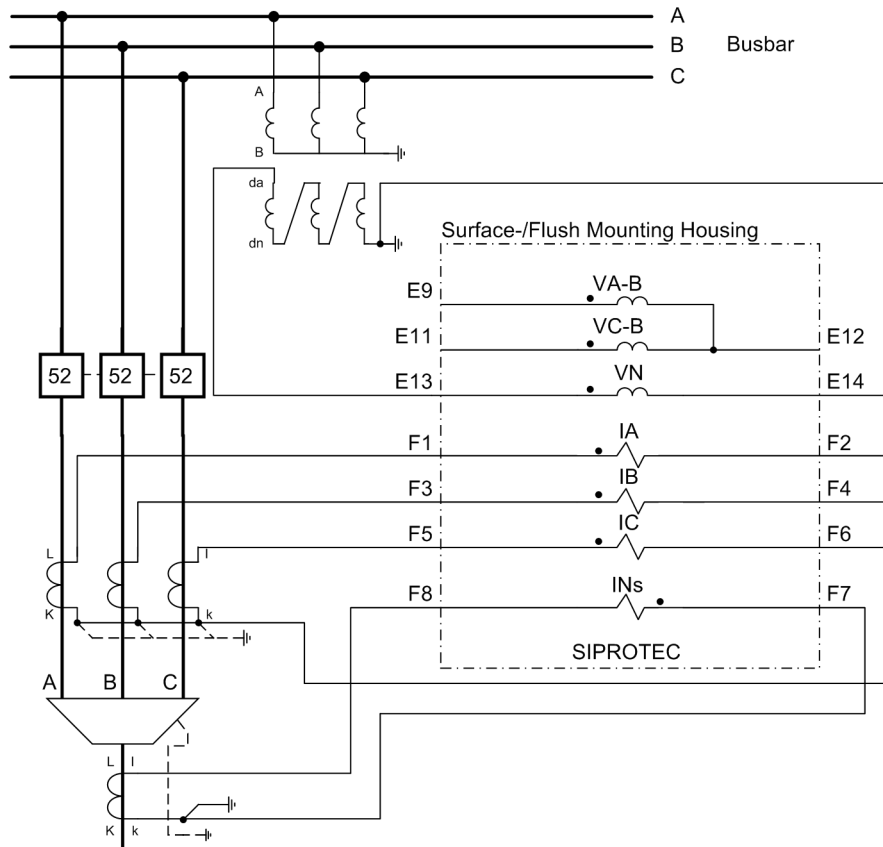

Figure A-17 Transformer connections to three current transformers, cable-type current transformer and broken delta winding, maximum precision for sensitive ground fault detection

Important: Grounding of the cable shield must be effected at the cable side

For busbar-side grounding of the current transformers, the current polarity of the device is changed via address 0201. This also reverses the polarity of the current input IN/INs. When using a cable-type current transformer, the connection of k and I at F8 and F7 must be exchanged.

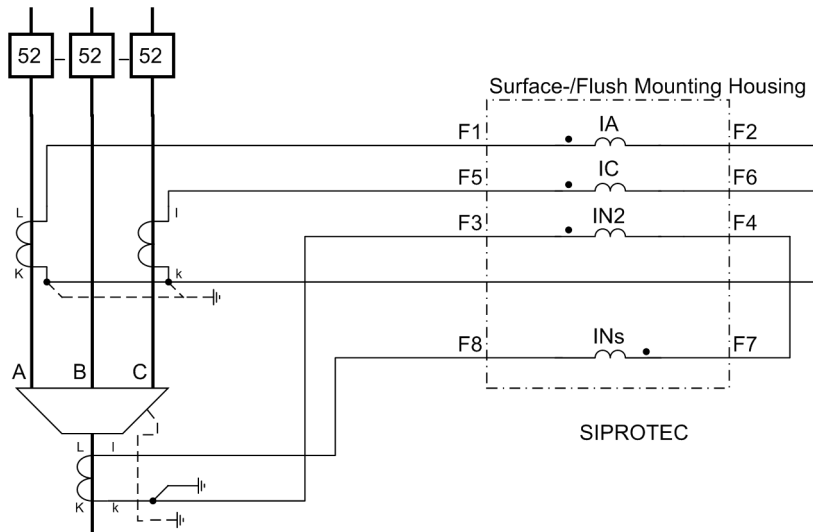

Figure A-18 Current transformer connections to two phase-current transformers and a ground-current transformer; the ground current is taken via the highly sensitive and sensitive ground input.

Important! Grounding of the cable shield must be effected at the cable side

For busbar-side grounding of the current transformers, the current polarity of the device is changed via address 0201. This also reverses the polarity of current input INs. When using a cable-type current transformer, the connection of k and I at F8 and F7 must be exchanged.

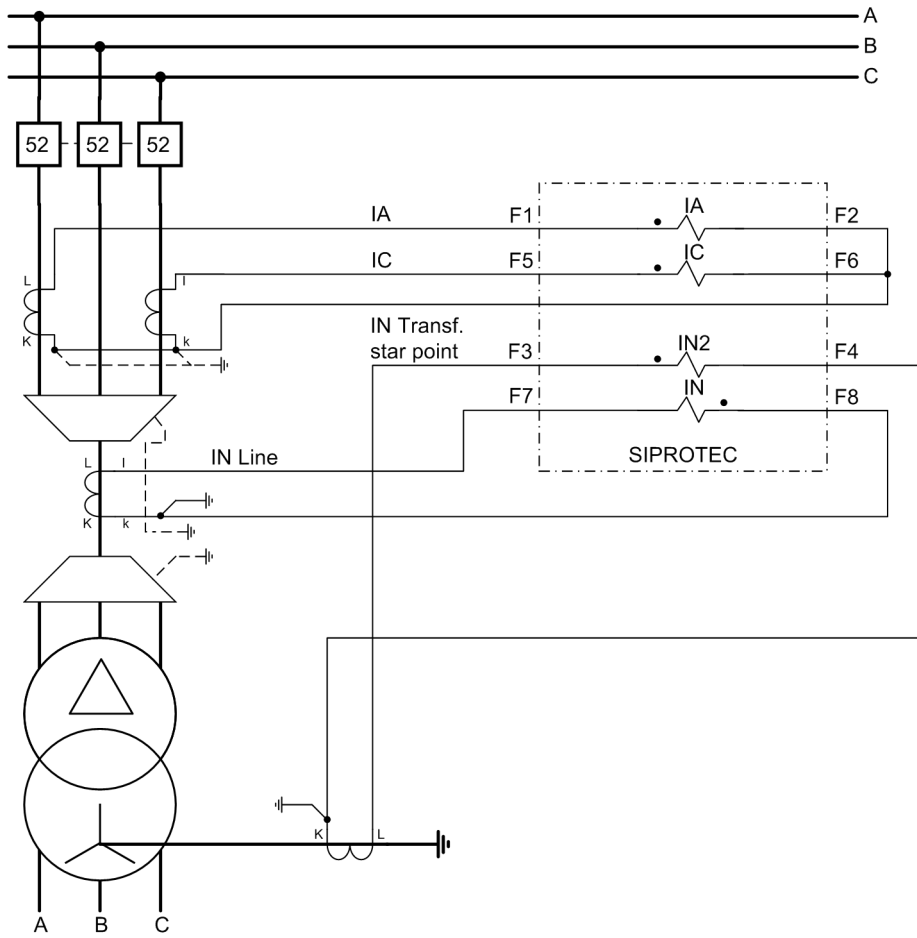

Figure A-19 Current transformer connections to two phase currents and two ground currents; IN/INs – ground current of the line, IN2 – ground current of the transformer star point

Important! Grounding of the cable shield must be effected at the cable side

For busbar-side grounding of the current transformers, the current polarity of the device is changed via address 0201. This also reverses the polarity of the current input IN/INs. When using a cable-type current transformer, the connection of k and l at F8 and F7 must be exchanged.

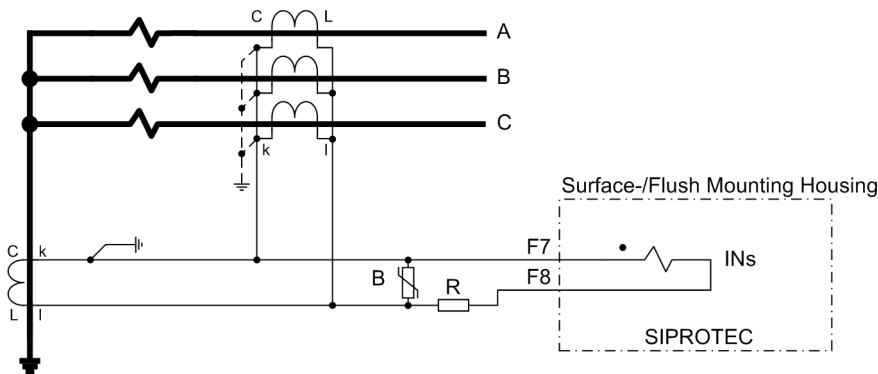

Figure A-20 High-impedance differential protection for a grounded transformer winding (the illustration shows the partial connection for high-impedance differential protection)

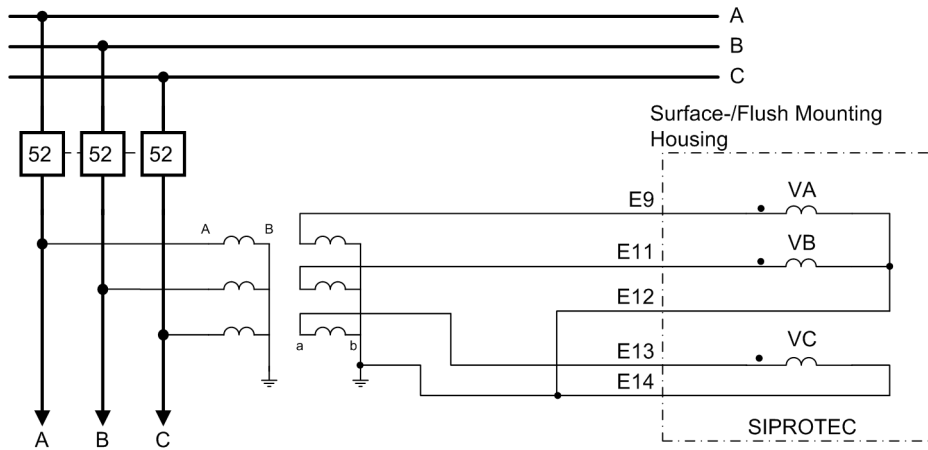

Figure A-21 Example for the connection type "VAN, VBN, VCN" with voltage connection on the feeder side

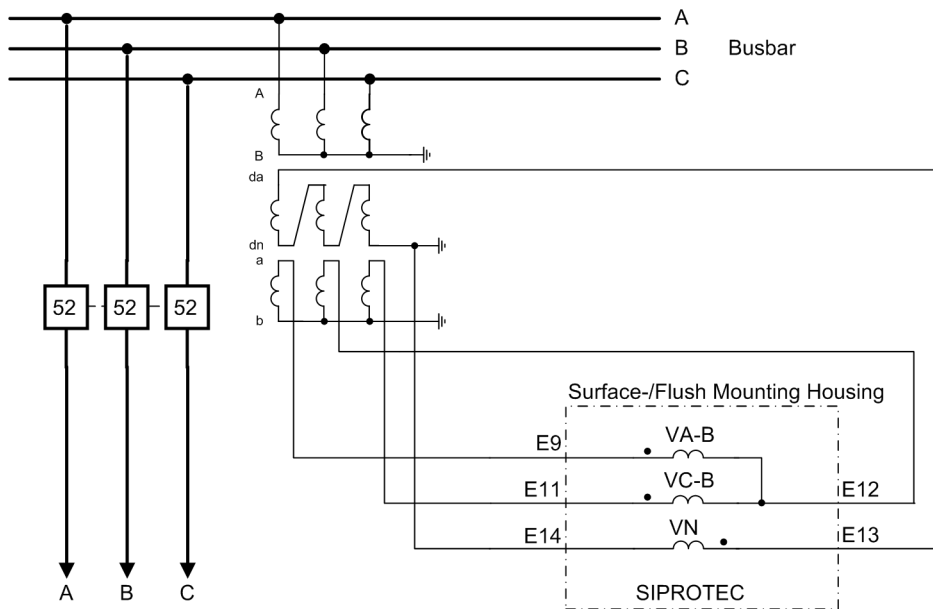

Figure A-22 Voltage transformer connections to two voltage transformers (phase-to-phase voltages) and broken delta winding (da-dn) – appropriate for all networks

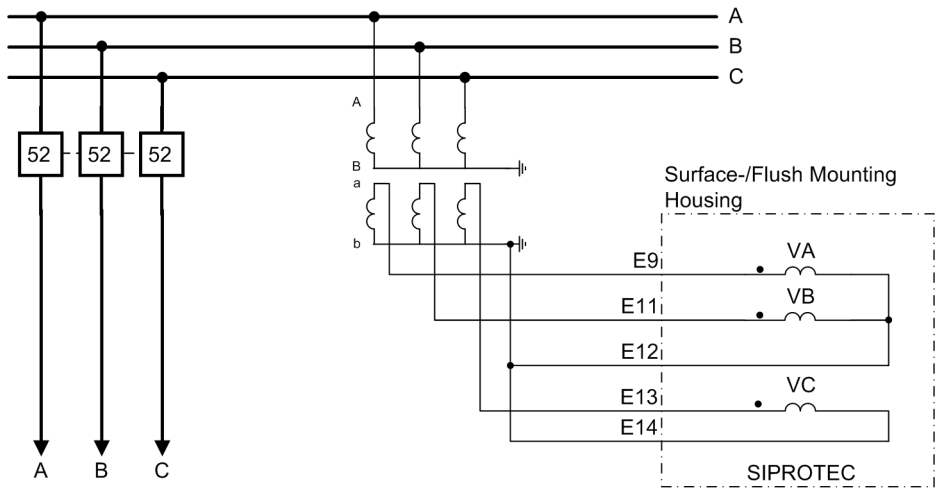

Figure A-23 Example for connection type "VAN, VBN, VCN" busbar-side voltage connection

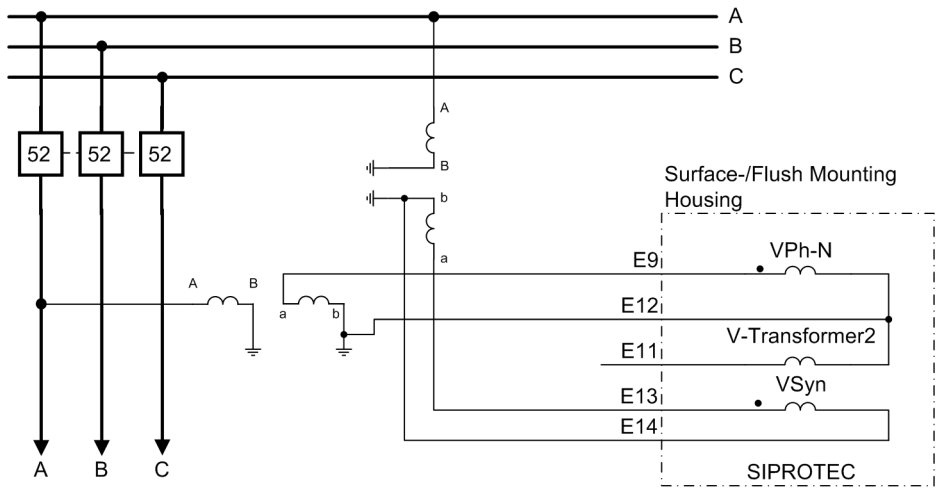

Figure A-24 Example for connection type "Vph-n, Vsyn"

The connection can be established at any one of the three phases. The phase must be the same for Vph-n and Vsyn.

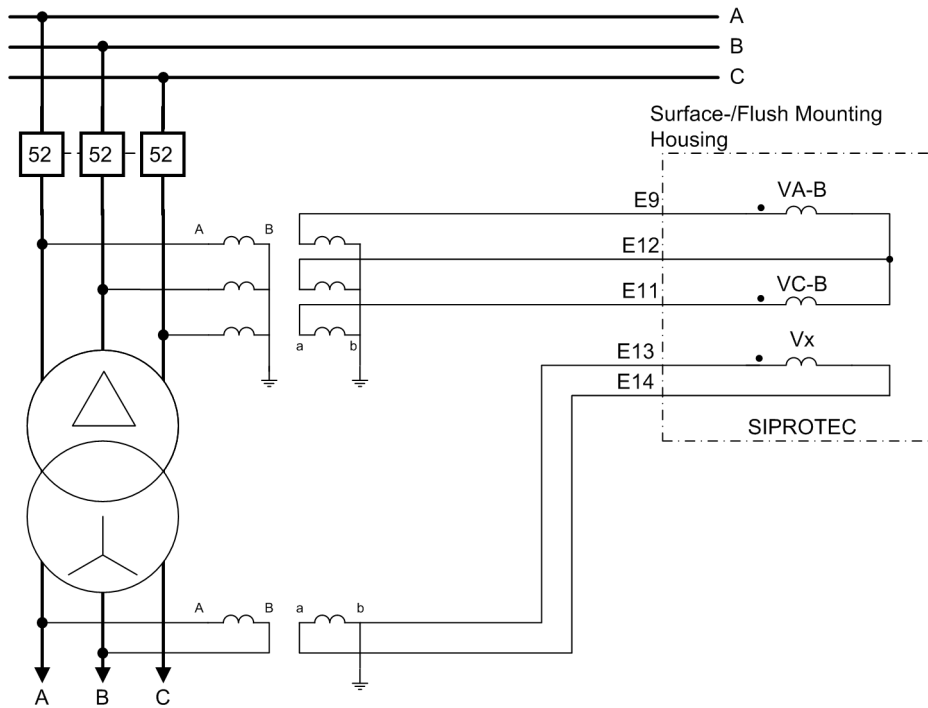

Figure A-25 Example for connection type "VAB, VBC, Vx"

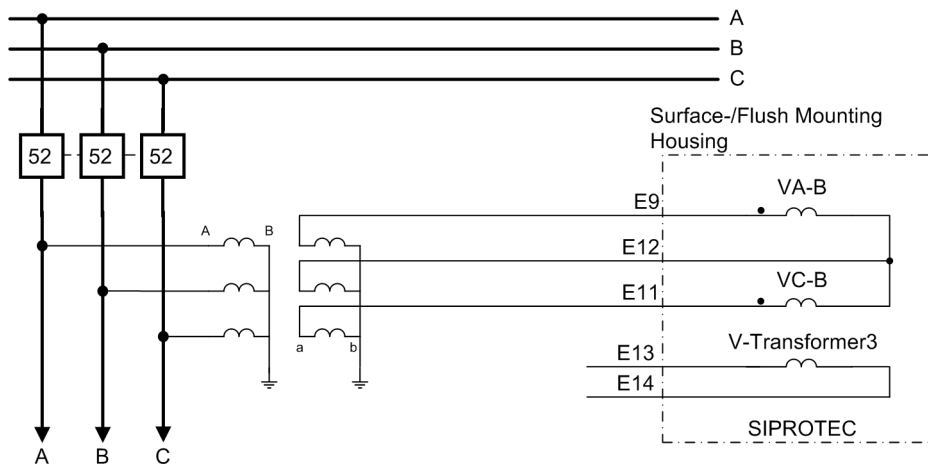

Figure A-26 Example for connection type "VAB, VBC"

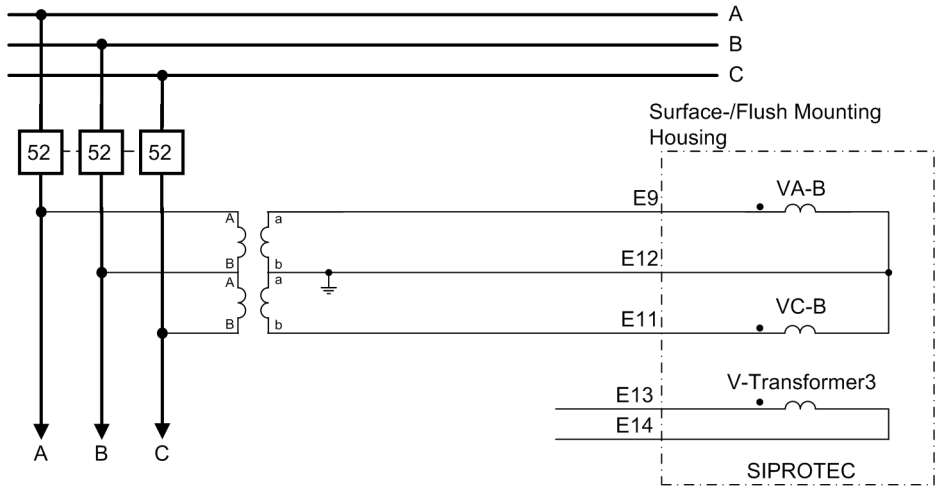

Figure A-27 Example for connection type "VAB, VBC" with phase voltage connection as open-delta connection

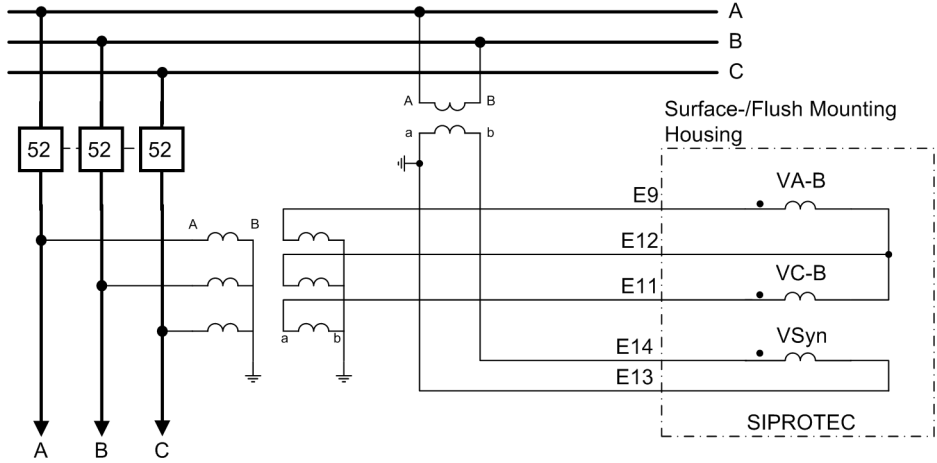

Figure A-28 Example for connection type "VAB, VBC, VSYN"

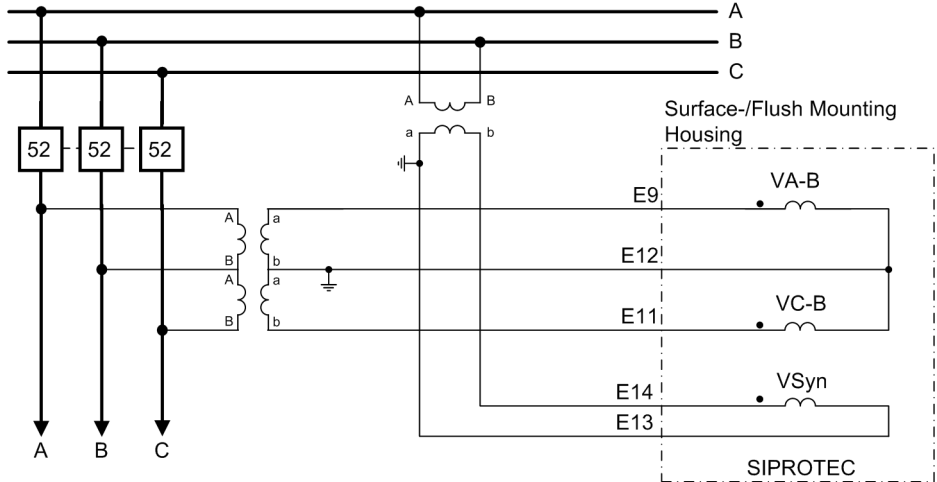

Figure A-29 Example for connection type "VAB, VBC, VSYN" with phase voltage connection as open-delta connection

A.3.1 Connection Examples for SICAM I/O Units

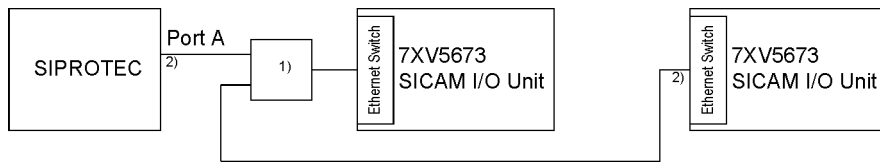

Figure A-30 Connection of 2 SICAM I/O units to port A via Y cable (up to 2 SICAM I/O units connectable)

- 1 Y cable 7KE6000-8GD00-0BA2
- 2 RJ45 cable

A.4 Current Transformer Requirements

The requirements for phase current transformers are usually determined by the overcurrent time protection, particularly by the high-current element settings. Besides, there is a minimum requirement based on experience.

The recommendations are given according to the standard IEC 60044-1.

The standards IEC 60044-6, BS 3938 and ANSI/IEEE C 57.13 are referred to for converting the requirement into the knee-point voltage and other transformer classes.

A.4.1 Accuracy limiting factors

Effective and Rated Accuracy Limiting Factor

Required minimum effective accuracy limiting factor	$K_{ALF'} = \frac{50 \cdot 2_{PU}}{I_{pNom}}$	
	but at least 20	
	with	
	$K_{ALF'}$	Minimum effective accuracy limiting factor
	$50 \cdot 2_{PU}$	Primary pickup value of the high-current element
Resulting rated accuracy limiting factor	I_{pNom}	Primary nominal transformer current
	$K_{ALF} = \frac{R_{BC} + R_{Ct}}{R_{BN} + R_{Ct}} \cdot K_{ALF'}$	
	with	
	K_{ALF}	Rated accuracy limiting factor
	R_{BC}	Connected burden resistance (device and cables)
	R_{BN}	Nominal burden resistance
	R_{Ct}	Transformer internal burden resistance

Calculation example according to IEC 60044-1

$I_{sNom} = 1 \text{ A}$	$K_{ALF} = \frac{0.6 + 3}{5 + 3} \cdot 20 = 9$
$K_{ALF'} = 20$	
$R_{BC} = 0.6 \ \Omega$ (device and cables)	
$R_{Ct} = 3 \ \Omega$	
$R_{BN} = 5 \ \Omega$ (5 VA)	K_{ALF} set to 10, so that: 5P10, 5 VA
with	
I_{sNom} = secondary transformer nominal current	

A.4.2 Class conversion

Table A-1 Conversion into other classes

British Standard BS 3938	$V_k = \frac{(R_{Ct} + R_{BN}) \cdot I_{sNom}}{1.3} \cdot K_{ALF}$	
ANSI/IEEE C 57.13, class C	$V_{s.t.max} = 20 \cdot I_{sNom} \cdot R_{BN} \cdot \frac{K_{ALF}}{20}$ $I_{sNom} = 5 \text{ A (typical value)}$	
IEC 60044-6 (transient response), class TPS Classes TPX, TPY, TPZ	$V_{al} = K \cdot k_{SSC} \cdot (R_{Ct} + R_{BN}) \cdot I_{sNom}$ $K \approx 1$ $K_{SSC} \approx K_{ALF}$ Calculation See Chapter A.4.1 Accuracy limiting factors with: $K_{SSC} \approx K_{ALF}$ T_p depending on power system and specified closing sequence	
	with	
	V_k	Knee-point voltage
	R_{Ct}	Internal burden resistance
	R_{BN}	Nominal burden resistance
	I_{sNom}	Secondary nominal transformer current
	K_{ALF}	Rated accuracy limiting factor
	$V_{s.t.max}$	Sec. terminal voltage at $20 I_{pNom}$
	V_{al}	Sec. magnetization limit voltage
	K	Dimensioning factor
	K_{SSC}	Factor symmetr. Rated fault current
	T_p	Primary time constant

A.4.3 Cable core balance current transformer

General

The requirements to the cable core balance current transformer are determined by the function „sensitive ground fault detection“.

The recommendations are given according to the standard IEC 60044-1.

Requirements

Transformation ratio, typical It may be necessary to select a different transformation ratio to suit the specific power system and thus the amount of the maximum ground fault current.	60 / 1
Accuracy limiting factor	FS = 10
Minimum power	1.2 VA
Maximum connected load – For secondary current threshold values $\geq 20 \text{ mA}$ – For secondary current threshold values $< 20 \text{ mA}$	$\leq 1.2 \text{ VA } (\leq 1.2 \Omega)$ $\leq 0.4 \text{ VA } (\leq 0.4 \Omega)$

Class accuracy

Table A-2 Minimum required class accuracy depending on neutral grounding and function operating principle

Neutral point	isolated	resonant-grounded	high-resistance grounded
Function directional	Class 1	Class 1	Class 1
Function non-directional	Class 3	Class 1	Class 3

For extremely small ground fault currents it may become necessary to correct the angle at the device (see function description of „sensitive ground fault detection“).

A.5 Default Settings

When the device leaves the factory, many LED indications, binary inputs, binary outputs and function keys are already preset. They are summarized in the following table.

A.5.1 LEDs

Table A-3 7SJ801*

LEDs	Default function	Function No.	Description
LED1	Relay TRIP	511	Relay GENERAL TRIP command
LED2	50/51 Ph A PU	1762	50/51 Phase A picked up
LED3	50/51 Ph B PU	1763	50/51 Phase B picked up
LED4	50/51 Ph C PU	1764	50/51 Phase C picked up
LED5	50N/51NPickedup	1765	50N/51N picked up
LED6	Failure Σ I	162	Failure: Current Summation
	Fail I balance	163	Failure: Current Balance
	Fail Ph. Seq. I	175	Failure: Phase Sequence Current
LED7	Not configured	1	No Function configured
LED8	Brk OPENED		Breaker OPENED

Table A-4 7SJ802*

LEDs	Default function	Function No.	Description
LED1	Relay TRIP	511	Relay GENERAL TRIP command
LED2	50/51 Ph A PU	1762	50/51 Phase A picked up
LED3	50/51 Ph B PU	1763	50/51 Phase B picked up
LED4	50/51 Ph C PU	1764	50/51 Phase C picked up
LED5	50N/51NPickedup	1765	50N/51N picked up
LED6	Failure Σ I	162	Failure: Current Summation
	Fail I balance	163	Failure: Current Balance
	Fail Ph. Seq. I	175	Failure: Phase Sequence Current
LED7	Not configured	1	No Function configured
LED8	Brk OPENED		Breaker OPENED

Table A-5 7SJ803*

LEDs	Default function	Function No.	Description
LED1	Relay TRIP	511	Relay GENERAL TRIP command
LED2	50/51 Ph A PU	1762	50/51 Phase A picked up
	67 A picked up	2692	67/67-TOC Phase A picked up
LED3	50/51 Ph B PU	1763	50/51 Phase B picked up
	67 B picked up	2693	67/67-TOC Phase B picked up
LED4	50/51 Ph C PU	1764	50/51 Phase C picked up
	67 C picked up	2694	67/67-TOC Phase C picked up
LED5	50N/51NPickedup	1765	50N/51N picked up
LED6	Failure Σ I	162	Failure: Current Summation
	Fail I balance	163	Failure: Current Balance
	Fail V balance	167	Failure: Voltage Balance
	Fail Ph. Seq. I	175	Failure: Phase Sequence Current
	Fail Ph. Seq. V	176	Failure: Phase Sequence Voltage
	VT brk. wire	253	Failure VT circuit: broken wire
LED7	Not configured	1	No Function configured
LED8	Brk OPENED		Breaker OPENED

Table A-6 7SJ804*

LEDs	Default function	Function No.	Description
LED1	Relay TRIP	511	Relay GENERAL TRIP command
LED2	50/51 Ph A PU 67 A picked up	1762 2692	50/51 Phase A picked up 67/67-TOC Phase A picked up
LED3	50/51 Ph B PU 67 B picked up	1763 2693	50/51 Phase B picked up 67/67-TOC Phase B picked up
LED4	50/51 Ph C PU 67 C picked up	1764 2694	50/51 Phase C picked up 67/67-TOC Phase C picked up
LED5	50N/51NPickedup 67N picked up	1765 2695	50N/51N picked up 67N/67N-TOC picked up
LED6	Failure Σ I Fail I balance Fail V balance Fail Ph. Seq. I Fail Ph. Seq. V VT brk. wire	162 163 167 175 176 253	Failure: Current Summation Failure: Current Balance Failure: Voltage Balance Failure: Phase Sequence Current Failure: Phase Sequence Voltage Failure VT circuit: broken wire
LED7	Not configured	1	No Function configured
LED8	Brk OPENED		Breaker OPENED

A.5.2 Binary Input

Table A-7 Binary input presettings for all devices and ordering variants

Binary Input	Default function	Function No.	Description
BI1	>BLOCK 50-2 >BLOCK 50N-2	1721 1724	>BLOCK 50-2 >BLOCK 50N-2
BI2	>52-b 52Breaker	4602	>52-b contact (OPEN, if bkr is closed) 52 Breaker
BI3	>52-a 52Breaker	4601	>52-a contact (OPEN, if bkr is open) 52 Breaker

Table A-8 Further binary input presettings for 7SJ802* or 7SJ804*

Binary Input	Default function	Function No.	Description
BI4	not pre-assigned	-	-
BI5	not pre-assigned	-	-
BI6	not pre-assigned	-	-
BI7	not pre-assigned	-	-

Table A-9 Further binary input presettings for 7SJ807* or 7SJ808*

Binary Input	Default function	Function No.	Description
BI4	not pre-assigned	-	-
BI5	not pre-assigned	-	-
BI6	not pre-assigned	-	-
BI7	not pre-assigned	-	-
BI8	not pre-assigned	-	-
BI9	not pre-assigned	-	-
BI10	not pre-assigned	-	-
BI11	not pre-assigned	-	-

A.5.3 Binary Output

Table A-10 Output Relay Presettings for All Devices and Ordering Variants

Binary Output	Default function	Function No.	Description
BO1	Relay TRIP 52Breaker	511	Relay GENERAL TRIP command 52 Breaker
BO2	52Breaker 79 Close	2851	52 Breaker 79 - Close command
BO3	52Breaker 79 Close	2851	52 Breaker 79 - Close command
BO4	Failure Σ I Fail I balance Fail V balance Fail Ph. Seq. I Fail Ph. Seq. V VT brk. wire	162 163 167 175 176 253	Failure: Current Summation Failure: Current Balance Failure: Voltage Balance Failure: Phase Sequence Current Failure: Phase Sequence Voltage Failure VT circuit: broken wire
BO5	Relay PICKUP	501	Relay PICKUP

Table A-11 Output Relay Presettings for CEI 0-16 (Ordering data position 14= G)

Binary Output	Default function	Function No.	Description
BO1	Relay TRIP	511	Relay GENERAL TRIP command
BO2	PI Trip NC	18424	PI Trip NC(ON,if Device ok & No Trip)
BO3	not pre-assigned	-	-
BO4	Failure Σ I Fail I balance Fail V balance Fail Ph. Seq. I Fail Ph. Seq. V VT brk. wire	162 163 167 175 176 253	Failure: Current Summation Failure: Current Balance Failure: Voltage Balance Failure: Phase Sequence Current Failure: Phase Sequence Voltage Failure VT circuit: broken wire
BO5	Relay PICKUP	501	Relay PICKUP

Table A-12 Further Output Relay Presettings for 7SJ802* or 7SJ804*

Binary Output	Default function	Function No.	Description
BO6	not pre-assigned	-	-
BO7	not pre-assigned	-	-
BO8	not pre-assigned	-	-

A.5.4 Function Keys

Table A-13 Applies to All Devices and Ordered Variants

Function Keys	Default function
F1	Display of the operational indications
F2	Display of the primary operational measured values
F3	Display of the last fault log buffer
F4	not pre-assigned
F5	not pre-assigned
F6	not pre-assigned
F7	not pre-assigned
F8	not pre-assigned
F9	not pre-assigned

A.5.5 Default Display

A number of pre-defined measured value pages are available depending on the device type. The start page of the default display appearing after startup of the device can be selected in the device data via parameter 640 **Start image DD**.

for the 6-line Display of 7SJ80

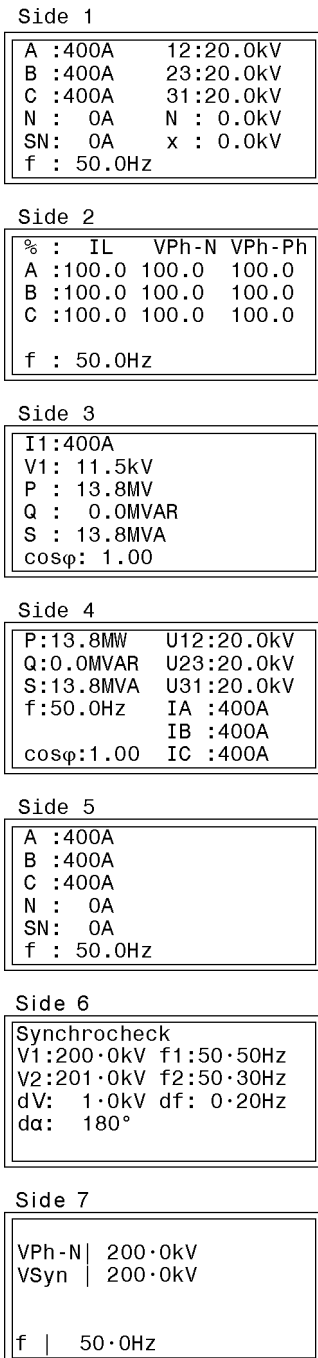

Figure A-31 Default display of the 7SJ80 for models with V without extended measured values

With the V0/IO φ measurement, the measured ground current IN2 is displayed under N and the ground current IN or INs under Ns.

Side 1

```
A :400A    12:20.0kV
B :400A    23:20.0kV
C :400A    31:20.0kV
N :  0A     N : 0.0kV
SN:  0A     x : 0.0kV
f : 50.0Hz
```

Side 2

```
% : IL  VPh-N VPh-Ph
A :100.0 100.0 100.0
B :100.0 100.0 100.0
C :100.0 100.0 100.0

f : 50.0Hz
```

Side 3

```
I1:400A
V1: 11.5kV
P : 13.8MW
Q : 0.0MVAR
S : 13.8MVA
cos $\varphi$ : 1.00
```

Side 4

```
P:13.8MW  A12:20.0kV
Q:0.0MVAR A23:20.0kV
S:13.8MVA A31:20.0kV
f:50.0Hz  IA :400A
           IB :400A
cos $\varphi$ :1.00 IC :400A
```

Side 5

```
A :400A    MAX400A
B :400A    MAX400A
C :400A    MAX400A
N :  0A
SN:  0A
f : 50.0Hz
```

Side 6

```
A :400A
B :400A
C :400A
N :  0A
SN:  0A
f : 50.0Hz
```

Side 7

```
Synchrocheck
V1:200.0kV f1:50.50Hz
V2:201.0kV f2:50.30Hz
dV: 1.0kV df: 0.20Hz
d $\alpha$ : 180°
```

Side 8

```
VPh-N | 200.0kV
VSyn  | 200.0kV

f | 50.0Hz
```

Figure A-32 Default display of the 7SJ80 for models with V with extended measured values

```

Side 1
A :400A      100%
B :400A      100%
C :400A      100%
N :  0A
SN:  0A
f : 50.0Hz
    
```

Figure A-33 Default display of the 7SJ80 for models without V and extended measured values

```

Side 1
A :400A      100%
B :400A      100%
C :400A      100%
N :  0A
SN:  0A
f : 50.0Hz
    
```

```

Side 2
A :400A      MAX400A
B :400A      MAX400A
C :400A      MAX400A
N :  0A
SN:  0A
f : 50.0Hz
    
```

Figure A-34 Default display of the 7SJ80 for models without V with extended measured values

Spontaneous Fault Display

After a fault has occurred, the most important fault data are automatically displayed after general device pickup in the order shown in the picture below.

50-1 PICKUP	Protective Function that Picked up First;
50-1 TRIP	Protective Function that Tripped Last;
T - Pickup	Operating Time from General Pickup to Dropout;
T - TRIP	Operating Time from General Pickup to the First Trip Command;

Figure A-35 Representation of spontaneous messages on the device display

A.6 Protocol-dependent Functions

Protocol → Function ↓	IEC 60870-5-103, single	IEC 60870-5-103, redundant	IEC 61850 Ethernet (EN 100)	PROFINET Ethernet (EN100)	Profibus DP	DNP3 TCP Ethernet (EN100)	DNP3.0 Modbus ASCII/RTU
Operational measured values	Yes	Yes	Yes	Yes	Yes	Yes	Yes
Metered values	Yes	Yes	Yes	Yes	Yes	Yes	Yes
Fault recording	Yes	Yes	Yes	No	No	Yes	No
Remote protection setting	No	Yes	Yes	No	No	No	No
User-defined indications and switching objects	Yes	Yes	Yes	Yes	Yes	Yes	Yes
Time synchronization	Yes	Yes	Yes	Yes	Yes	Yes	Yes
Messages with time stamp	Yes	Yes	Yes	Yes	Yes	Yes	Yes
Commissioning aids							
Data transmission stop	Yes	Yes	Yes	No	No	No	No
Creating test messages	Yes	Yes	Yes	No	No	No	No
Physical mode	Asynchronous	Asynchronous	Synchronous		Asynchronous		Asynchronous
Transmission mode	cyclic/event	cyclic/event	cyclic/event	cyclically	cyclic	cyclically / event	cyclic/event ^(DNP) cyclic ^(Modbus)
Baud rate	1,200 to 115,000	2,400 to 57,600	Up to 100 MBaud	up to 100 MBaud	up to 1.5 MBaud (optical fiber) 6 MBaud (RS485)	up to 100 MBaud	9600 to 57600 ^(DNP) 300 to 57600 ^(Modbus)
Type	RS232 RS485 optical fiber	RS485	Ethernet TP Ethernet optical fiber	Ethernet TP	RS485 optical fiber (double ring)	Ethernet TP Ethernet optical fiber	RS485 optical fiber

A.7 Functional Scope

A.7.1 Functional Scope (Global Standard)

Addr.	Parameter	Setting Options	Default Setting	Comments
103	Grp Chge OPTION	Disabled Enabled	Disabled	Setting Group Change Option
104	OSC. FAULT REC.	Disabled Enabled	Enabled	Oscillographic Fault Records
112	Charac. Phase	Disabled Definite Time TOC IEC TOC ANSI	Definite Time	50/51
113	Charac. Ground	Disabled Definite Time TOC IEC TOC ANSI	Definite Time	50N/51N
115	67/67-TOC	Disabled Definite Time TOC IEC TOC ANSI	Definite Time	67, 67-TOC
116	67N/67N-TOC	Disabled Definite Time TOC IEC TOC ANSI	Definite Time	67N, 67N-TOC
117	Coldload Pickup	Disabled Enabled	Disabled	Cold Load Pickup
122	InrushRestraint	Disabled Enabled	Disabled	2nd Harmonic Inrush Restraint
127	50 1Ph	Disabled Enabled	Disabled	50 1Ph
130	S.Gnd.F.Dir.Ch	$\cos \varphi / \sin \varphi$ V0/I0 φ mea.	$\cos \varphi / \sin \varphi$	(sens.) Ground fault dir. characteristic
131	Sens. Gnd Fault	Disabled Definite Time User Defined PU	Disabled	(sensitive) Ground fault
133	INTERM.EF	Disabled with Ignd with 3I0 with Ignd,sens.	Disabled	Intermittent earth fault protection
134	Dir. Interm. EF	Disabled Enabled	Disabled	Dir. Intermittent earth fault protection
140	46	Disabled TOC ANSI TOC IEC Definite Time	Disabled	46 Negative Sequence Protection
142	49	Disabled No ambient temp	No ambient temp	49 Thermal Overload Protection
150	27/59	Disabled Enabled	Disabled	27, 59 Under/Overvoltage Protection
154	81 O/U	Disabled Enabled	Disabled	81 Over/Underfrequency Protection

Addr.	Parameter	Setting Options	Default Setting	Comments
155	27/Q-Protection	Disabled Enabled	Disabled	27 / Q dir. con. Protection
161	25 Function 1	Disabled SYNCHROCHECK	Disabled	25 Function group 1
170	50BF	Disabled Enabled enabled w/ 3I0>	Disabled	50BF Breaker Failure Protection
171	79 Auto Recl.	Disabled Enabled	Disabled	79 Auto-Reclose Function
172	52 B.WEAR MONIT	Disabled I _x -Method 2P-Method I _{2t} -Method	Disabled	52 Breaker Wear Monitoring
180	Fault Locator	Disabled Enabled	Disabled	Fault Locator
181	L-sections FL	1 Section 2 Sections 3 Sections	1 Section	Line sections for fault locator
182	74 Trip Ct Supv	Disabled 2 Binary Inputs 1 Binary Input	Disabled	74TC Trip Circuit Supervision
192	Cap. Volt.Meas.	NO YES	NO	Capacitive voltage measurement
617	ServiProt (CM)	Disabled T103 DIGSI	T103	Port B usage
-	FLEXIBLE FUNC. 1...20	Flex. Function 01 Flex. Function 02 Flex. Function 03 Flex. Function 04 Flex. Function 05 Flex. Function 06 Flex. Function 07 Flex. Function 08 Flex. Function 09 Flex. Function 10 Flex. Function 11 Flex. Function 12 Flex. Function 13 Flex. Function 14 Flex. Function 15 Flex. Function 16 Flex. Function 17 Flex. Function 18 Flex. Function 19 Flex. Function 20	Please select	Flexible Functions

A.7.2 Functional Scope (CEI 0-16 Standard)

Addr.	Parameter	Setting Options	Default Setting	Comments
103	Grp Chge OPTION	Disabled Enabled	Disabled	Setting Group Change Option
104	OSC. FAULT REC.	Disabled Enabled	Enabled	Oscillographic Fault Records

Addr.	Parameter	Setting Options	Default Setting	Comments
112	Charac. Phase	Disabled Definite Time TOC IEC TOC ANSI	Disabled	50/51
113	Charac. Ground	Disabled Definite Time TOC IEC TOC ANSI	Disabled	50N/51N
115	67/67-TOC	Disabled Definite Time TOC IEC TOC ANSI	Definite Time	67, 67-TOC
116	67N/67N-TOC	Disabled Definite Time TOC IEC TOC ANSI	Disabled	67N, 67N-TOC
117	Coldload Pickup	Disabled Enabled	Disabled	Cold Load Pickup
122	InrushRestraint	Disabled Enabled	Disabled	2nd Harmonic Inrush Restraint
127	50 1Ph	Disabled Enabled	Disabled	50 1Ph
130	S.Gnd.F.Dir.Ch	$\cos \varphi / \sin \varphi$ V0/I0 φ mea.	V0/I0 φ mea.	(sens.) Ground fault dir. characteristic
131	Sens. Gnd Fault	Disabled Definite Time User Defined PU	Disabled	(sensitive) Ground fault
133	INTERM.EF	Disabled with Ignd with 3I0 with Ignd,sens.	Disabled	Intermittent earth fault protection
134	Dir. Interm. EF	Disabled Enabled	Disabled	Dir. Intermittent earth fault protection
140	46	Disabled TOC ANSI TOC IEC Definite Time	Disabled	46 Negative Sequence Protection
142	49	Disabled No ambient temp	Disabled	49 Thermal Overload Protection
150	27/59	Disabled Enabled	Enabled	27, 59 Under/Overvoltage Protection
154	81 O/U	Disabled Enabled	Enabled	81 Over/Underfrequency Protection
155	27/Q-Protection	Disabled Enabled	Disabled	27 / Q dir. con. Protection
161	25 Function 1	Disabled SYNCHROCHECK	Disabled	25 Function group 1
170	50BF	Disabled Enabled enabled w/ 3I0>	Disabled	50BF Breaker Failure Protection
171	79 Auto Recl.	Disabled Enabled	Disabled	79 Auto-Reclose Function

Addr.	Parameter	Setting Options	Default Setting	Comments
172	52 B.WEAR MONIT	Disabled I _x -Method 2P-Method I _{2t} -Method	Disabled	52 Breaker Wear Monitoring
180	Fault Locator	Disabled Enabled	Disabled	Fault Locator
181	L-sections FL	1 Section 2 Sections 3 Sections	1 Section	Line sections for fault locator
182	74 Trip Ct Supv	Disabled 2 Binary Inputs 1 Binary Input	Disabled	74TC Trip Circuit Supervision
192	Cap. Volt.Meas.	NO YES	NO	Capacitive voltage measurement
617	ServiProt (CM)	Disabled T103 DIGSI	T103	Port B usage
-	FLEXIBLE FUNC. 1...20	Flex. Function 01 Flex. Function 02 Flex. Function 03 Flex. Function 04 Flex. Function 05 Flex. Function 06 Flex. Function 07 Flex. Function 08 Flex. Function 09 Flex. Function 10 Flex. Function 11 Flex. Function 12 Flex. Function 13 Flex. Function 14 Flex. Function 15 Flex. Function 16 Flex. Function 17 Flex. Function 18 Flex. Function 19 Flex. Function 20	Please select	Flexible Functions

A.8 Settings

Addresses which have an appended "A" can only be changed with DIGSI, under "Display Additional Settings".

The table indicates region-specific default settings. Column C (configuration) indicates the corresponding secondary nominal current of the current transformer.

Addr.	Parameter	Function	C	Setting Options	Default Setting	Comments
0	FLEXIBLE FUNC.	Flx		OFF ON Alarm Only	OFF	Flexible Function
0	OPERRAT. MODE	Flx		3-phase 1-phase no reference	3-phase	Mode of Operation
0	BLK f out of r	Flx		YES NO	YES	Block while Freq. is out of range
0	MEAS. QUANTITY	Flx		Please select Current Voltage P forward P reverse Q forward Q reverse Power factor dV/dt rising dV/dt falling Frequency df/dt rising df/dt falling Binray Input	Please select	Selection of Measured Quantity
0	MEAS. METHOD	Flx		Fundamental True RMS Positive seq. Negative seq. Zero sequence Ratio I2/I1	Fundamental	Selection of Measurement Method
0	PICKUP WITH	Flx		Exceeding Dropping below	Exceeding	Pickup with
0	CURRENT	Flx		Ia Ib Ic In In sensitive In2	Ia	Current
0	VOLTAGE	Flx		Please select Va-n Vb-n Vc-n Va-b Vb-c Vc-a Vn Vx	Please select	Voltage
0	POWER	Flx		Ia Va-n Ib Vb-n Ic Vc-n	Ia Va-n	Power
0	VOLTAGE SYSTEM	Flx		Phase-Phase Phase-Ground	Phase-Phase	Voltage System
0	P.U. THRESHOLD	Flx		0.05 .. 40.00 A	2.00 A	Pickup Threshold
0	P.U. THRESHOLD	Flx	1A	0.05 .. 40.00 A	2.00 A	Pickup Threshold
			5A	0.25 .. 200.00 A	10.00 A	
0	P.U. THRESHOLD	Flx	1A	0.001 .. 1.500 A	0.100 A	Pickup Threshold
			5A	0.005 .. 7.500 A	0.500 A	
0	P.U. THRESHOLD	Flx		2.0 .. 260.0 V	110.0 V	Pickup Threshold
0	P.U. THRESHOLD	Flx		2.0 .. 200.0 V	110.0 V	Pickup Threshold
0	P.U. THRESHOLD	Flx		40.00 .. 60.00 Hz	51.00 Hz	Pickup Threshold
0	P.U. THRESHOLD	Flx		50.00 .. 70.00 Hz	61.00 Hz	Pickup Threshold
0	P.U. THRESHOLD	Flx		0.10 .. 20.00 Hz/s	5.00 Hz/s	Pickup Threshold

Addr.	Parameter	Function	C	Setting Options	Default Setting	Comments
0	P.U. THRESHOLD	Flx	1A	2.0 .. 10000.0 W	200.0 W	Pickup Threshold
			5A	10.0 .. 50000.0 W	1000.0 W	
0	P.U. THRESHOLD	Flx		-0.99 .. 0.99	0.50	Pickup Threshold
0	P.U. THRESHOLD	Flx		15 .. 100 %	20 %	Pickup Threshold
0	P.U. THRESHOLD	Flx		4 .. 100 V/s	60 V/s	Pickup Threshold
0	P.U. THRESHOLD	Flx		2.0 .. 260.0 V	110.0 V	Pickup Threshold
0	T TRIP DELAY	Flx		0.00 .. 3600.00 sec	1.00 sec	Trip Time Delay
0A	T PICKUP DELAY	Flx		0.00 .. 60.00 sec	0.00 sec	Pickup Time Delay
0	T PICKUP DELAY	Flx		0.00 .. 28800.00 sec	0.00 sec	Pickup Time Delay
0A	T DROPOUT DELAY	Flx		0.00 .. 60.00 sec	0.00 sec	Dropout Time Delay
0A	BLK.by Vol.Loss	Flx		NO YES	YES	Block in case of Meas.-Voltage Loss
0A	DROPOUT RATIO	Flx		0.70 .. 0.99	0.95	Dropout Ratio
0A	DROPOUT RATIO	Flx		1.01 .. 3.00	1.05	Dropout Ratio
0	DO differential	Flx		0.02 .. 1.00 Hz	0.03 Hz	Dropout differential
132	GND CT Scaling	Device, General		Sensitive Normal	Normal	Ground CT Scaling
201	CT Starpoint	P.System Data 1		towards Line towards Busbar	towards Line	CT Starpoint
202	Vnom PRIMARY	P.System Data 1		0.10 .. 800.00 kV	20.00 kV	Rated Primary Voltage
203	Vnom SECONDARY	P.System Data 1		34 .. 225 V	100 V	Rated Secondary Voltage (L-L)
204	CT PRIMARY	P.System Data 1		10 .. 50000 A	400 A	CT Rated Primary Current
205	CT SECONDARY	P.System Data 1		1A 5A	1A	CT Rated Secondary Current
206A	Vph / Vdelta	P.System Data 1		1.00 .. 3.00	1.73	Matching ratio Phase-VT To Open-Delta-VT
206A	Vph / Vdelta	P.System Data 1		1.00 .. 3.00	3.00	Matching ratio Phase-VT To Open-Delta-VT (For CEI 0-16)
209	PHASE SEQ.	P.System Data 1		A B C A C B	A B C	Phase Sequence
210A	TMin TRIP CMD	P.System Data 1		0.01 .. 32.00 sec	0.15 sec	Minimum TRIP Command Duration
211A	TMax CLOSE CMD	P.System Data 1		0.01 .. 32.00 sec	1.00 sec	Maximum Close Command Duration
212	BkrClosed I MIN	P.System Data 1	1A	0.04 .. 1.00 A	0.04 A	Closed Breaker Min. Current Threshold
			5A	0.20 .. 5.00 A	0.20 A	
213	VT Connect. 3ph	P.System Data 1		Van, Vbn, Vcn Vab, Vbc, VGnd Vab, Vbc, VSyn Vab, Vbc Vph-g, VSyn Vab, Vbc, Vx	Van, Vbn, Vcn	VT Connection, three-phase
213	VT Connect. 3ph	P.System Data 1		Vab, Vbc, VGnd	Vab, Vbc, VGnd	VT Connection, three-phase (For CEI 0-16)
214	Rated Frequency	P.System Data 1		50 Hz 60 Hz	50 Hz	Rated Frequency
215	Distance Unit	P.System Data 1		km Miles	km	Distance measurement unit
217	Ignd-CT PRIM	P.System Data 1		1 .. 50000 A	60 A	Ignd-CT rated primary current
218	Ignd-CT SEC	P.System Data 1		1A 5A	1A	Ignd-CT rated secondary current
220	Threshold BI 1	P.System Data 1		Thresh. BI 176V Thresh. BI 88V Thresh. BI 19V	Thresh. BI 176V	Threshold for Binary Input 1
221	Threshold BI 2	P.System Data 1		Thresh. BI 176V Thresh. BI 88V Thresh. BI 19V	Thresh. BI 176V	Threshold for Binary Input 2
222	Threshold BI 3	P.System Data 1		Thresh. BI 176V Thresh. BI 88V Thresh. BI 19V	Thresh. BI 176V	Threshold for Binary Input 3
223	Threshold BI 4	P.System Data 1		Thresh. BI 176V Thresh. BI 88V Thresh. BI 19V	Thresh. BI 176V	Threshold for Binary Input 4

Addr.	Parameter	Function	C	Setting Options	Default Setting	Comments
224	Threshold BI 5	P.System Data 1		Thresh. BI 176V Thresh. BI 88V Thresh. BI 19V	Thresh. BI 176V	Threshold for Binary Input 5
225	Threshold BI 6	P.System Data 1		Thresh. BI 176V Thresh. BI 88V Thresh. BI 19V	Thresh. BI 176V	Threshold for Binary Input 6
226	Threshold BI 7	P.System Data 1		Thresh. BI 176V Thresh. BI 88V Thresh. BI 19V	Thresh. BI 176V	Threshold for Binary Input 7
227	Threshold BI 8	P.System Data 1		Thresh. BI 176V Thresh. BI 88V Thresh. BI 19V	Thresh. BI 176V	Threshold for Binary Input 8
228	Threshold BI 9	P.System Data 1		Thresh. BI 176V Thresh. BI 88V Thresh. BI 19V	Thresh. BI 176V	Threshold for Binary Input 9
229	Threshold BI 10	P.System Data 1		Thresh. BI 176V Thresh. BI 88V Thresh. BI 19V	Thresh. BI 176V	Threshold for Binary Input 10
230	Threshold BI 11	P.System Data 1		Thresh. BI 176V Thresh. BI 88V Thresh. BI 19V	Thresh. BI 176V	Threshold for Binary Input 11
232	VXnom PRIMARY	P.System Data 1		0.10 .. 800.00 kV	20.00 kV	Rated Primary Voltage X
233	VXnom SECONDARY	P.System Data 1		100 .. 225 V	100 V	Rated Secondary Voltage X
235A	ATEX100	P.System Data 1		NO YES	YES	Storage of th. Replicas w/o Power Supply
238	Ignd2-CT PRIM.	P.System Data 1		1 .. 50000 A	400 A	Ignd2-CT rated primary c. (conn. to I2)
239	Ignd2-CT SEC.	P.System Data 1		1A 5A	1A	Ignd2-CT rated secondary current (I2)
241	Volt.trans.A:C1	P.System Data 1		1.0 .. 100.0 pF	10.0 pF	Voltage transducer A: Capacity C1
242	Volt.trans.A:C2	P.System Data 1		250 .. 10000 pF	2200 pF	Voltage transducer A: Capacity C2
243	Volt.trans.B:C1	P.System Data 1		1.0 .. 100.0 pF	10.0 pF	Voltage transducer B: Capacity C1
244	Volt.trans.B:C2	P.System Data 1		250 .. 10000 pF	2200 pF	Voltage transducer B: Capacity C2
245	Volt.trans.C:C1	P.System Data 1		1.0 .. 100.0 pF	10.0 pF	Voltage transducer C: Capacity C1
246	Volt.trans.C:C2	P.System Data 1		250 .. 10000 pF	2200 pF	Voltage transducer C: Capacity C2
250A	50/51 2-ph prot	P.System Data 1		OFF ON	OFF	50, 51 Time Overcurrent with 2ph. prot.
251A	CT Connect.	P.System Data 1		A, B, C, (Gnd) A,G2,C,G; G->B A,G2,C,G; G2->B	A, B, C, (Gnd)	CT Connection
252	Ph LPCT pol.	P.System Data 1		not reversed reversed	not reversed	Phase LPCT orientation / polarity
260	I _r -52	P.System Data 1		10 .. 50000 A	125 A	Rated Normal Current (52 Breaker)
261	OP.CYCLES AT I _r	P.System Data 1		100 .. 1000000	10000	Switching Cycles at Rated Normal Current
262	I _{sc} -52	P.System Data 1		10 .. 100000 A	25000 A	Rated Short-Circuit Breaking Current
263	OP.CYCLES I _{sc}	P.System Data 1		1 .. 1000	50	Switch. Cycles at Rated Short-Cir. Curr.
264	I _x EXPONENT	P.System Data 1		1.0 .. 3.0	2.0	Exponent for the I _x -Method
265	Cmd.via control	P.System Data 1		(Setting options depend on configuration)	None	52 B.Wear: Open Cmd. via Control Device
266	T 52 BREAKTIME	P.System Data 1		1 .. 600 ms	80 ms	Breaktime (52 Breaker)
267	T 52 OPENING	P.System Data 1		1 .. 500 ms	65 ms	Opening Time (52 Breaker)
280	Holmgr. for ΣI	P.System Data 1		NO YES	NO	Holmgreen-conn. (for fast sum-i-monit.)

Addr.	Parameter	Function	C	Setting Options	Default Setting	Comments
302	CHANGE	Change Group		Group A Group B Group C Group D Binary Input Protocol	Group A	Change to Another Setting Group
310	Iph-PRIM ref.	P.System Data 1		10 .. 50000 A	400 A	Primary refer. phase current for prot.
311	Iph-LPCT PRIM	P.System Data 1		1 .. 5000 A	400 A	Rated primary phase current LPCT
312	Ignd-PRIM ref.	P.System Data 1		1 .. 50000 A	60 A	Primary refer. ground current for prot.
313	Ignd-LPCT PRIM	P.System Data 1		0.01 .. 5000.00 A	2.00 A	Rated primary ground current LPCT
314	Vph-LPCT SEC	P.System Data 1		10.0 .. 1000.0 mV	225.0 mV	Rated secondary phase voltage LPCT
315	Vgnd-LPCT SEC	P.System Data 1		10.0 .. 1000.0 mV	225.0 mV	Rated secondary ground voltage LPCT
320A	Corr.factor IL1	P.System Data 1		0.9000 .. 1.1000	1.0000	Correction factor for magnitude IL1
321A	Corr.factor IL2	P.System Data 1		0.9000 .. 1.1000	1.0000	Correction factor for magnitude IL2
322A	Corr.factor IL3	P.System Data 1		0.9000 .. 1.1000	1.0000	Correction factor for magnitude IL3
323A	Corr.factor IE	P.System Data 1		0.9000 .. 1.1000	1.0000	Correction factor for magnitude IE
324A	Corr.factor IEE	P.System Data 1		0.9000 .. 1.1000	1.0000	Correction factor for magnitude IEE
330	V-LPVT SEC	P.System Data 1		3.00 .. 17.00 V	3.25 V	rated secondary voltage LPVT
332A	V-LPVT PHA	P.System Data 1		-10.00 .. 10.00 °	0.00 °	phase angle LPVT
401	WAVEFORMTRIGGER	Osc. Fault Rec.		Save w. Pickup Save w. TRIP Start w. TRIP	Save w. Pickup	Waveform Capture
402	WAVEFORM DATA	Osc. Fault Rec.		Fault event Pow.Sys.Flt.	Fault event	Scope of Waveform Data
403	MAX. LENGTH	Osc. Fault Rec.		0.30 .. 5.00 sec	2.00 sec	Max. length of a Waveform Capture Record
404	PRE. TRIG. TIME	Osc. Fault Rec.		0.05 .. 0.50 sec	0.25 sec	Captured Waveform Prior to Trigger
405	POST REC. TIME	Osc. Fault Rec.		0.05 .. 0.50 sec	0.10 sec	Captured Waveform after Event
406	BinIn CAPT.TIME	Osc. Fault Rec.		0.10 .. 5.00 sec; ∞	0.50 sec	Capture Time via Binary Input
610	FitDisp.LED/LCD	Device, General		Target on PU Target on TRIP	Target on PU	Fault Display on LED / LCD
611	Spont. FitDisp.	Device, General		YES NO	NO	Spontaneous display of flt.annunciations
613A	Gnd O/Cprot. w.	P.System Data 1		Ignd (measured) 3I0 (calcul.)	Ignd (measured)	Ground Overcurrent protection with
614A	OP. QUANTITY 59	P.System Data 1		Vphph Vph-n V1 V2	Vphph	Opera. Quantity for 59 Overvolt. Prot.
614A	OP. QUANTITY 59	P.System Data 1		Vphph	Vphph	Opera. Quantity for 59 Overvolt. Prot. (For CEI 0-16)
615A	OP. QUANTITY 27	P.System Data 1		V1 Vphph Vph-n	V1	Opera. Quantity for 27 Undervolt. Prot.
616	STATIC GEN.	P.System Data 1		YES NO	NO	Static or non self-exc. Asyn. Generator
640	Start image DD	Device, General		image 1 image 2 image 3 image 4 image 5 image 6	image 1	Start image Default Display
651	ParEN100(LC)blk	Device, General		OFF ON	OFF	DIGSI-config. over EN100 (LC) blocked

Appendix
A.8 Settings

Addr.	Parameter	Function	C	Setting Options	Default Setting	Comments
660	IP adr[0](Prim)	Device, General		0 .. 255	0	IP address [0] (NTP-Primary)
661	IP adr[1](Prim)	Device, General		0 .. 255	0	IP address [1] (NTP-Primary)
662	IP adr[2](Prim)	Device, General		0 .. 255	0	IP address [2] (NTP-Primary)
663	IP adr[3](Prim)	Device, General		0 .. 255	0	IP address [3] (NTP-Primary)
664	IP adr[0] (Sec)	Device, General		0 .. 255	0	IP address [0] (NTP-Sekundary)
665	IP adr[1] (Sec)	Device, General		0 .. 255	0	IP address [1] (NTP-Sekundary)
666	IP adr[2] (Sec)	Device, General		0 .. 255	0	IP address [2] (NTP-Sekundary)
667	IP adr[3] (Sec)	Device, General		0 .. 255	0	IP address [3] (NTP-Sekundary)
668	Client activ	Device, General		OFF ON	OFF	Client activ
669	Daylight Set	Device, General		OFF ON	OFF	Daylight Set
670	Offset TZ/min	Device, General		-1440 .. 1440 min	60 min	Offset for time zone in minutes
671	Offset DayT/min	Device, General		-1440 .. 1440 min	60 min	Offset for daylight in minutes
672	W2S month	Device, General		1 .. 12	3	month of time set winter to summer
673	W2S week	Device, General		1 .. 5	5	week of time set winter to summer
674	W2S day	Device, General		Monday Tuesday Wednesday Thursday Friday Saturday Sunday	Sunday	day of time set winter to summer
675	W2S hour	Device, General		1 .. 24	2	hour of time set winter to summer
676	S2W month	Device, General		1 .. 12	10	month of time set summer to winter
677	S2W week	Device, General		1 .. 5	5	week of time set summer to winter
678	S2W day	Device, General		Monday Tuesday Wednesday Thursday Friday Saturday Sunday	Sunday	day of time set summer to winter
679	S2W hour	Device, General		1 .. 24	3	hour of time set summer to winter
700	GOOSE-Stop	Device, General		YES NO	NO	GOOSE-Stop
1101	FullScaleVolt.	P.System Data 2		0.10 .. 800.00 kV	20.00 kV	Measuram:FullScaleVoltage(Equipm.rating)
1102	FullScaleCurr.	P.System Data 2		10 .. 50000 A	400 A	Measuram:FullScaleCurrent(Equipm.rating)
1103	RE/RL	P.System Data 2		-0.33 .. 7.00	1.00	Zero seq. compensating factor RE/RL
1104	XE/XL	P.System Data 2		-0.33 .. 7.00	1.00	Zero seq. compensating factor XE/XL
1105	x'	P.System Data 2	1A	0.0050 .. 15.0000 Ω/mi	0.2420 Ω/mi	feeder reactance per mile: x'
			5A	0.0010 .. 3.0000 Ω/mi	0.0484 Ω/mi	
1106	x'	P.System Data 2	1A	0.0050 .. 9.5000 Ω/km	0.1500 Ω/km	feeder reactance per km: x'
			5A	0.0010 .. 1.9000 Ω/km	0.0300 Ω/km	
1107	I MOTOR START	P.System Data 2	1A	0.40 .. 10.00 A	2.50 A	Motor Start Current (Block 49, Start 48)
			5A	2.00 .. 50.00 A	12.50 A	
1108	P,Q sign	P.System Data 2		not reversed reversed	not reversed	P,Q operational measured values sign
1109	Line angle	P.System Data 2		10 .. 89 °	85 °	Line angle
1110	Line length	P.System Data 2		0.1 .. 1000.0 km	100.0 km	Line length in kilometer
1111	Line length	P.System Data 2		0.1 .. 650.0 Miles	62.1 Miles	Line length in miles
1201	FCT 50/51	50/51 Overcur.		ON OFF	ON	50, 51 Phase Time Overcurrent
1202	50-2 PICKUP	50/51 Overcur.	1A	0.10 .. 35.00 A; ∞	4.00 A	50-2 Pickup
			5A	0.50 .. 175.00 A; ∞	20.00 A	

Addr.	Parameter	Function	C	Setting Options	Default Setting	Comments
1203	50-2 DELAY	50/51 Overcur.		0.00 .. 60.00 sec; ∞	0.00 sec	50-2 Time Delay
1204	50-1 PICKUP	50/51 Overcur.	1A	0.10 .. 35.00 A; ∞	1.00 A	50-1 Pickup
			5A	0.50 .. 175.00 A; ∞	5.00 A	
1205	50-1 DELAY	50/51 Overcur.		0.00 .. 60.00 sec; ∞	0.50 sec	50-1 Time Delay
1207	51 PICKUP	50/51 Overcur.	1A	0.10 .. 4.00 A	1.00 A	51 Pickup
			5A	0.50 .. 20.00 A	5.00 A	
1208	51 TIME DIAL	50/51 Overcur.		0.05 .. 3.20 sec; ∞	0.50 sec	51 Time Dial
1209	51 TIME DIAL	50/51 Overcur.		0.50 .. 15.00 ; ∞	5.00	51 Time Dial
1210	51 Drop-out	50/51 Overcur.		Instantaneous Disk Emulation	Disk Emulation	Drop-out characteristic
1211	51 IEC CURVE	50/51 Overcur.		Normal Inverse Very Inverse Extremely Inv. Long Inverse	Normal Inverse	IEC Curve
1212	51 ANSI CURVE	50/51 Overcur.		Very Inverse Inverse Short Inverse Long Inverse Moderately Inv. Extremely Inv. Definite Inv.	Very Inverse	ANSI Curve
1213A	MANUAL CLOSE	50/51 Overcur.		50-3 instant. 50-2 instant. 50 -1 instant. 51 instant. Inactive	50-2 instant.	Manual Close Mode
1214A	50-2 active	50/51 Overcur.		Always with 79 active	Always	50-2 active
1215A	50 T DROP-OUT	50/51 Overcur.		0.00 .. 60.00 sec	0.00 sec	50 Drop-Out Time Delay
1216A	50-3 active	50/51 Overcur.		Always with 79 active	Always	50-3 active
1217	50-3 PICKUP	50/51 Overcur.	1A	1.00 .. 35.00 A; ∞	∞ A	50-3 Pickup
			5A	5.00 .. 175.00 A; ∞	∞ A	
1218	50-3 DELAY	50/51 Overcur.		0.00 .. 60.00 sec; ∞	0.00 sec	50-3 Time Delay
1219A	50-3 measur.	50/51 Overcur.		Fundamental True RMS Instantaneous	Fundamental	50-3 measurement of
1220A	50-2 measur.	50/51 Overcur.		Fundamental True RMS	Fundamental	50-2 measurement of
1221A	50-1 measur.	50/51 Overcur.		Fundamental True RMS	Fundamental	50-1 measurement of
1222A	51 measur.	50/51 Overcur.		Fundamental True RMS	Fundamental	51 measurement of
1223	VOLT. INFLUENCE	50/51 Overcur.		NO Volt. controll. Volt. restraint	NO	51V Voltage Influence
1224	51V V<	50/51 Overcur.		10.0 .. 125.0 V	75.0 V	51V V< Threshold for Release Ip
1301	FCT 50N/51N	50/51 Overcur.		ON OFF	ON	50N, 51N Ground Time Overcurrent
1302	50N-2 PICKUP	50/51 Overcur.	1A	0.05 .. 35.00 A; ∞	0.50 A	50N-2 Pickup
			5A	0.25 .. 175.00 A; ∞	2.50 A	
1303	50N-2 DELAY	50/51 Overcur.		0.00 .. 60.00 sec; ∞	0.10 sec	50N-2 Time Delay
1304	50N-1 PICKUP	50/51 Overcur.	1A	0.05 .. 35.00 A; ∞	0.20 A	50N-1 Pickup
			5A	0.25 .. 175.00 A; ∞	1.00 A	
1305	50N-1 DELAY	50/51 Overcur.		0.00 .. 60.00 sec; ∞	0.50 sec	50N-1 Time Delay
1307	51N PICKUP	50/51 Overcur.	1A	0.05 .. 4.00 A	0.20 A	51N Pickup
			5A	0.25 .. 20.00 A	1.00 A	
1308	51N TIME DIAL	50/51 Overcur.		0.05 .. 3.20 sec; ∞	0.20 sec	51N Time Dial
1309	51N TIME DIAL	50/51 Overcur.		0.50 .. 15.00 ; ∞	5.00	51N Time Dial
1310	51N Drop-out	50/51 Overcur.		Instantaneous Disk Emulation	Disk Emulation	Drop-Out Characteristic

Appendix
A.8 Settings

Addr.	Parameter	Function	C	Setting Options	Default Setting	Comments
1311	51N IEC CURVE	50/51 Overcur.		Normal Inverse Very Inverse Extremely Inv. Long Inverse	Normal Inverse	IEC Curve
1312	51N ANSI CURVE	50/51 Overcur.		Very Inverse Inverse Short Inverse Long Inverse Moderately Inv. Extremely Inv. Definite Inv.	Very Inverse	ANSI Curve
1313A	MANUAL CLOSE	50/51 Overcur.		50N-3 instant. 50N-2 instant. 50N-1 instant. 51N instant. Inactive	50N-2 instant.	Manual Close Mode
1314A	50N-2 active	50/51 Overcur.		Always With 79 Active	Always	50N-2 active
1315A	50N T DROP-OUT	50/51 Overcur.		0.00 .. 60.00 sec	0.00 sec	50N Drop-Out Time Delay
1316A	50N-3 active	50/51 Overcur.		Always with 79 active	Always	50N-3 active
1317	50N-3 PICKUP	50/51 Overcur.		0.25 .. 35.00 A; ∞	∞ A	50N-3 Pickup
1318	50N-3 DELAY	50/51 Overcur.		0.00 .. 60.00 sec; ∞	0.05 sec	50N-3 Time Delay
1319A	50N-3 measurem.	50/51 Overcur.		Fundamental True RMS Instantaneous	Fundamental	50N-3 measurement of
1320A	50N-2 measurem.	50/51 Overcur.		Fundamental True RMS	Fundamental	50N-2 measurement of
1321A	50N-1 measurem.	50/51 Overcur.		Fundamental True RMS	Fundamental	50N-1 measurement of
1322A	51N measurem.	50/51 Overcur.		Fundamental True RMS	Fundamental	51N measurement of
1501	FCT 67/67-TOC	67 Direct. O/C		OFF ON	OFF	67, 67-TOC Phase Time Over-current
1502	67-2 PICKUP	67 Direct. O/C	1A	0.10 .. 35.00 A; ∞	2.00 A	67-2 Pickup
			5A	0.50 .. 175.00 A; ∞	10.00 A	
1503	67-2 DELAY	67 Direct. O/C		0.00 .. 60.00 sec; ∞	0.10 sec	67-2 Time Delay
1504	67-1 PICKUP	67 Direct. O/C	1A	0.10 .. 35.00 A; ∞	1.00 A	67-1 Pickup
			5A	0.50 .. 175.00 A; ∞	5.00 A	
1505	67-1 DELAY	67 Direct. O/C		0.00 .. 60.00 sec; ∞	0.50 sec	67-1Time Delay
1507	67-TOC PICKUP	67 Direct. O/C	1A	0.10 .. 4.00 A	1.00 A	67-TOC Pickup
			5A	0.50 .. 20.00 A	5.00 A	
1508	67 TIME DIAL	67 Direct. O/C		0.05 .. 3.20 sec; ∞	0.50 sec	67-TOC Time Dial
1509	67 TIME DIAL	67 Direct. O/C		0.50 .. 15.00 ; ∞	5.00	67-TOC Time Dial
1510	67-TOC Drop-out	67 Direct. O/C		Instantaneous Disk Emulation	Disk Emulation	Drop-Out Characteristic
1511	67- IEC CURVE	67 Direct. O/C		Normal Inverse Very Inverse Extremely Inv. Long Inverse	Normal Inverse	IEC Curve
1512	67- ANSI CURVE	67 Direct. O/C		Very Inverse Inverse Short Inverse Long Inverse Moderately Inv. Extremely Inv. Definite Inv.	Very Inverse	ANSI Curve
1513A	MANUAL CLOSE	67 Direct. O/C		67-3 instant. 67-2 instant. 67-1 instant. 67-TOC instant. Inactive	67-2 instant.	Manual Close Mode
1514A	67-2 active	67 Direct. O/C		with 79 active always	always	67-2 active
1518A	67 T DROP-OUT	67 Direct. O/C		0.00 .. 60.00 sec	0.00 sec	67 Drop-Out Time Delay
1519A	ROTATION ANGLE	67 Direct. O/C		-180 .. 180 °	45 °	Rotation Angle of Reference Voltage

Addr.	Parameter	Function	C	Setting Options	Default Setting	Comments
1520A	67-2 MEASUREM.	67 Direct. O/C		Fundamental True RMS	Fundamental	67-2 measurement of
1521A	67-1 MEASUREM.	67 Direct. O/C		Fundamental True RMS	Fundamental	67-1 measurement of
1522A	67-TOC MEASUR.	67 Direct. O/C		Fundamental True RMS	Fundamental	67-TOC measurement of
1523	67-2 Direction	67 Direct. O/C		Forward Reverse Non-Directional	Forward	67-2 Direction
1524	67-1 Direction	67 Direct. O/C		Forward Reverse Non-Directional	Forward	67-1 Direction
1525	67-TOC Direct.	67 Direct. O/C		Forward Reverse Non-Directional	Forward	67-TOC Direction
1526	67-3 Direction	67 Direct. O/C		Forward Reverse Non-Directional	Forward	67-3 Direction
1527A	67-3 MEASUREM.	67 Direct. O/C		Fundamental True RMS	Fundamental	67-3 measurement of
1528	67-3 PICKUP	67 Direct. O/C	1A	1.00 .. 35.00 A; ∞	∞ A	67-3 Pickup
			5A	5.00 .. 175.00 A; ∞	∞ A	
1529	67-3 DELAY	67 Direct. O/C		0.00 .. 60.00 sec; ∞	0.00 sec	67-3 Time Delay
1532A	67-3 active	67 Direct. O/C		always with 79 active	always	67-3 active
1601	FCT 67N/67N-TOC	67 Direct. O/C		OFF ON	OFF	67N, 67N-TOC Ground Time Overcurrent
1602	67N-2 PICKUP	67 Direct. O/C	1A	0.05 .. 35.00 A; ∞	0.50 A	67N-2 Pickup
			5A	0.25 .. 175.00 A; ∞	2.50 A	
1603	67N-2 DELAY	67 Direct. O/C		0.00 .. 60.00 sec; ∞	0.10 sec	67N-2 Time Delay
1604	67N-1 PICKUP	67 Direct. O/C	1A	0.05 .. 35.00 A; ∞	0.20 A	67N-1 Pickup
			5A	0.25 .. 175.00 A; ∞	1.00 A	
1605	67N-1 DELAY	67 Direct. O/C		0.00 .. 60.00 sec; ∞	0.50 sec	67N-1 Time Delay
1607	67N-TOC PICKUP	67 Direct. O/C	1A	0.05 .. 4.00 A	0.20 A	67N-TOC Pickup
			5A	0.25 .. 20.00 A	1.00 A	
1608	67N-TOC T-DIAL	67 Direct. O/C		0.05 .. 3.20 sec; ∞	0.20 sec	67N-TOC Time Dial
1609	67N-TOC T-DIAL	67 Direct. O/C		0.50 .. 15.00 ; ∞	5.00	67N-TOC Time Dial
1610	67N-TOC DropOut	67 Direct. O/C		Instantaneous Disk Emulation	Disk Emulation	Drop-Out Characteristic
1611	67N-TOC IEC	67 Direct. O/C		Normal Inverse Very Inverse Extremely Inv. Long Inverse	Normal Inverse	IEC Curve
1612	67N-TOC ANSI	67 Direct. O/C		Very Inverse Inverse Short Inverse Long Inverse Moderately Inv. Extremely Inv. Definite Inv.	Very Inverse	ANSI Curve
1613A	MANUAL CLOSE	67 Direct. O/C		67N-3 instant. 67N-2 instant. 67N-1 instant. 67N-TOC instant Inactive	67N-2 instant.	Manual Close Mode
1614A	67N-2 active	67 Direct. O/C		always with 79 active	always	67N-2 active
1617	67N POLARIZAT.	67 Direct. O/C		with VN and IN with V2 and I2	with VN and IN	Ground Polarization
1618A	67N T DROP-OUT	67 Direct. O/C		0.00 .. 60.00 sec	0.00 sec	67N Drop-Out Time Delay
1619A	ROTATION ANGLE	67 Direct. O/C		-180 .. 180 °	-45 °	Rotation Angle of Reference Voltage
1620A	67N-2 MEASUREM.	67 Direct. O/C		Fundamental True RMS	Fundamental	67N-2 measurement of

Appendix
A.8 Settings

Addr.	Parameter	Function	C	Setting Options	Default Setting	Comments
1621A	67N-1 MEASUREM.	67 Direct. O/C		Fundamental True RMS	Fundamental	67N-1 measurement of
1622A	67N-TOC MEASUR.	67 Direct. O/C		Fundamental True RMS	Fundamental	67N-TOC measurement of
1623	67N-2 Direction	67 Direct. O/C		Forward Reverse Non-Directional	Forward	67N-2 Direction
1624	67N-1 Direction	67 Direct. O/C		Forward Reverse Non-Directional	Forward	67N-1 Direction
1625	67N-TOC Direct.	67 Direct. O/C		Forward Reverse Non-Directional	Forward	67N-TOC Direction
1626	67N-3 Direction	67 Direct. O/C		Forward Reverse Non-Directional	Forward	67N-3 Direction
1627A	67N-3 MEASUREM.	67 Direct. O/C		Fundamental True RMS	Fundamental	67N-3 measurement of
1628	67N-3 PICKUP	67 Direct. O/C		0.50 .. 35.00 A; ∞	∞ A	67N-3 Pickup
1629	67N-3 DELAY	67 Direct. O/C		0.00 .. 60.00 sec; ∞	0.00 sec	67N-3 Time Delay
1632A	67N-3 active	67 Direct. O/C		always with 79 active	always	67N-3 active
1701	COLDLOAD PICKUP	ColdLoadPickup		OFF ON	OFF	Cold-Load-Pickup Function
1702	Start Condition	ColdLoadPickup		No Current Breaker Contact 79 ready	No Current	Start Condition
1703	CB Open Time	ColdLoadPickup		0 .. 21600 sec	3600 sec	Circuit Breaker OPEN Time
1704	Active Time	ColdLoadPickup		0 .. 21600 sec	3600 sec	Active Time
1705	Stop Time	ColdLoadPickup		1 .. 600 sec; ∞	600 sec	Stop Time
1801	50c-2 PICKUP	ColdLoadPickup	1A	0.10 .. 35.00 A; ∞	10.00 A	50c-2 Pickup
			5A	0.50 .. 175.00 A; ∞	50.00 A	
1802	50c-2 DELAY	ColdLoadPickup		0.00 .. 60.00 sec; ∞	0.00 sec	50c-2 Time Delay
1803	50c-1 PICKUP	ColdLoadPickup	1A	0.10 .. 35.00 A; ∞	2.00 A	50c-1 Pickup
			5A	0.50 .. 175.00 A; ∞	10.00 A	
1804	50c-1 DELAY	ColdLoadPickup		0.00 .. 60.00 sec; ∞	0.30 sec	50c-1 Time Delay
1805	51c PICKUP	ColdLoadPickup	1A	0.10 .. 4.00 A	1.50 A	51c Pickup
			5A	0.50 .. 20.00 A	7.50 A	
1806	51c TIME DIAL	ColdLoadPickup		0.05 .. 3.20 sec; ∞	0.50 sec	51c Time dial
1807	51c TIME DIAL	ColdLoadPickup		0.50 .. 15.00 ; ∞	5.00	51c Time dial
1808	50c-3 PICKUP	ColdLoadPickup	1A	1.00 .. 35.00 A; ∞	∞ A	50c-3 Pickup
			5A	5.00 .. 175.00 A; ∞	∞ A	
1809	50c-3 DELAY	ColdLoadPickup		0.00 .. 60.00 sec; ∞	0.00 sec	50c-3 Time Delay
1901	50Nc-2 PICKUP	ColdLoadPickup	1A	0.05 .. 35.00 A; ∞	7.00 A	50Nc-2 Pickup
			5A	0.25 .. 175.00 A; ∞	35.00 A	
1902	50Nc-2 DELAY	ColdLoadPickup		0.00 .. 60.00 sec; ∞	0.00 sec	50Nc-2 Time Delay
1903	50Nc-1 PICKUP	ColdLoadPickup	1A	0.05 .. 35.00 A; ∞	1.50 A	50Nc-1 Pickup
			5A	0.25 .. 175.00 A; ∞	7.50 A	
1904	50Nc-1 DELAY	ColdLoadPickup		0.00 .. 60.00 sec; ∞	0.30 sec	50Nc-1 Time Delay
1905	51Nc PICKUP	ColdLoadPickup	1A	0.05 .. 4.00 A	1.00 A	51Nc Pickup
			5A	0.25 .. 20.00 A	5.00 A	
1906	51Nc T-DIAL	ColdLoadPickup		0.05 .. 3.20 sec; ∞	0.50 sec	51Nc Time Dial
1907	51Nc T-DIAL	ColdLoadPickup		0.50 .. 15.00 ; ∞	5.00	51Nc Time Dial
1908	50Nc-3 PICKUP	ColdLoadPickup		0.05 .. 35.00 A; ∞	∞ A	50Nc-3 Pickup
1909	50Nc-3 DELAY	ColdLoadPickup		0.00 .. 60.00 sec; ∞	0.00 sec	50Nc-3 Time Delay
2001	67c-2 PICKUP	ColdLoadPickup	1A	0.10 .. 35.00 A; ∞	10.00 A	67c-2 Pickup
			5A	0.50 .. 175.00 A; ∞	50.00 A	
2002	67c-2 DELAY	ColdLoadPickup		0.00 .. 60.00 sec; ∞	0.00 sec	67c-2 Time Delay

Addr.	Parameter	Function	C	Setting Options	Default Setting	Comments
2003	67c-1 PICKUP	ColdLoadPickup	1A	0.10 .. 35.00 A; ∞	2.00 A	67c-1 Pickup
			5A	0.50 .. 175.00 A; ∞	10.00 A	
2004	67c-1 DELAY	ColdLoadPickup		0.00 .. 60.00 sec; ∞	0.30 sec	67c-1 Time Delay
2005	67c-TOC PICKUP	ColdLoadPickup	1A	0.10 .. 4.00 A	1.50 A	67c Pickup
			5A	0.50 .. 20.00 A	7.50 A	
2006	67c-TOC T-DIAL	ColdLoadPickup		0.05 .. 3.20 sec; ∞	0.50 sec	67c Time Dial
2007	67c-TOC T-DIAL	ColdLoadPickup		0.50 .. 15.00 ; ∞	5.00	67c Time Dial
2008	67c-3 PICKUP	ColdLoadPickup	1A	1.00 .. 35.00 A; ∞	∞ A	67c-3 Pickup
			5A	5.00 .. 175.00 A; ∞	∞ A	
2009	67c-3 DELAY	ColdLoadPickup		0.00 .. 60.00 sec; ∞	0.00 sec	67c-3 Time Delay
2101	67Nc-2 PICKUP	ColdLoadPickup	1A	0.05 .. 35.00 A; ∞	7.00 A	67Nc-2 Pickup
			5A	0.25 .. 175.00 A; ∞	35.00 A	
2102	67Nc-2 DELAY	ColdLoadPickup		0.00 .. 60.00 sec; ∞	0.00 sec	67Nc-2 Time Delay
2103	67Nc-1 PICKUP	ColdLoadPickup	1A	0.05 .. 35.00 A; ∞	1.50 A	67Nc-1 Pickup
			5A	0.25 .. 175.00 A; ∞	7.50 A	
2104	67Nc-1 DELAY	ColdLoadPickup		0.00 .. 60.00 sec; ∞	0.30 sec	67Nc-1 Time Delay
2105	67Nc-TOC PICKUP	ColdLoadPickup	1A	0.05 .. 4.00 A	1.00 A	67Nc-TOC Pickup
			5A	0.25 .. 20.00 A	5.00 A	
2106	67Nc-TOC T-DIAL	ColdLoadPickup		0.05 .. 3.20 sec; ∞	0.50 sec	67Nc-TOC Time Dial
2107	67Nc-TOC T-DIAL	ColdLoadPickup		0.50 .. 15.00 ; ∞	5.00	67Nc-TOC Time Dial
2108	67Nc-3 PICKUP	ColdLoadPickup		0.25 .. 35.00 A; ∞	∞ A	67Nc-3 Pickup
2109	67Nc-3 DELAY	ColdLoadPickup		0.00 .. 60.00 sec; ∞	0.00 sec	67Nc-3 Time Delay
2201	INRUSH REST.	50/51 Overcur.		OFF ON	OFF	Inrush Restraint
2202	2nd HARMONIC	50/51 Overcur.		10 .. 45 %	15 %	2nd. harmonic in % of fundamental
2203	CROSS BLOCK	50/51 Overcur.		NO YES	NO	Cross Block
2204	CROSS BLK TIMER	50/51 Overcur.		0.00 .. 180.00 sec	0.00 sec	Cross Block Time
2205	I Max	50/51 Overcur.	1A	0.30 .. 25.00 A	7.50 A	Maximum Current for Inrush Restraint
			5A	1.50 .. 125.00 A	37.50 A	
2701	50 1Ph	50 1Ph		OFF ON	OFF	50 1Ph
2703	50 1Ph-2 PICKUP	50 1Ph	1A	0.001 .. 1.600 A; ∞	0.300 A	50 1Ph-2 Pickup
			5A	0.005 .. 8.000 A; ∞	1.500 A	
2704	50 1Ph-2 DELAY	50 1Ph		0.00 .. 60.00 sec; ∞	0.10 sec	50 1Ph-2 Time Delay
2706	50 1Ph-1 PICKUP	50 1Ph	1A	0.001 .. 1.600 A; ∞	0.100 A	50 1Ph-1 Pickup
			5A	0.005 .. 8.000 A; ∞	0.500 A	
2707	50 1Ph-1 DELAY	50 1Ph		0.00 .. 60.00 sec; ∞	0.50 sec	50 1Ph-1 Time Delay
3101	Sens. Gnd Fault	Sens. Gnd Fault		OFF ON ON with GF log Alarm Only	OFF	(Sensitive) Ground Fault
3102	CT Err. I1	Sens. Gnd Fault	1A	0.001 .. 1.600 A	0.050 A	Current I1 for CT Angle Error
			5A	0.005 .. 8.000 A	0.250 A	
3102	CT Err. I1	Sens. Gnd Fault	1A	0.05 .. 35.00 A	1.00 A	Current I1 for CT Angle Error
			5A	0.25 .. 175.00 A	5.00 A	
3103	CT Err. F1	Sens. Gnd Fault		0.0 .. 5.0 °	0.0 °	CT Angle Error at I1
3104	CT Err. I2	Sens. Gnd Fault	1A	0.001 .. 1.600 A	1.000 A	Current I2 for CT Angle Error
			5A	0.005 .. 8.000 A	5.000 A	
3104	CT Err. I2	Sens. Gnd Fault	1A	0.05 .. 35.00 A	10.00 A	Current I2 for CT Angle Error
			5A	0.25 .. 175.00 A	50.00 A	
3105	CT Err. F2	Sens. Gnd Fault		0.0 .. 5.0 °	0.0 °	CT Angle Error at I2
3106	VPH MIN	Sens. Gnd Fault		10 .. 100 V	40 V	L-Gnd Voltage of Faulted Phase Vph Min
3107	VPH MAX	Sens. Gnd Fault		10 .. 100 V	75 V	L-Gnd Voltage of Unfaulted Phase Vph Max

Appendix
A.8 Settings

Addr.	Parameter	Function	C	Setting Options	Default Setting	Comments
3109	64-1 VGND	Sens. Gnd Fault		1.8 .. 200.0 V; ∞	40.0 V	64-1 Ground Displacement Voltage
3110	64-1 VGND	Sens. Gnd Fault		10.0 .. 225.0 V; ∞	70.0 V	64-1 Ground Displacement Voltage
3111	T-DELAY Pickup	Sens. Gnd Fault		0.04 .. 320.00 sec; ∞	1.00 sec	Time-DELAY Pickup
3112	64-1 DELAY	Sens. Gnd Fault		0.10 .. 40000.00 sec; ∞	10.00 sec	64-1 Time Delay
3113	50Ns-2 PICKUP	Sens. Gnd Fault	1A	0.001 .. 1.600 A	0.300 A	50Ns-2 Pickup
			5A	0.005 .. 8.000 A	1.500 A	
3113	50Ns-2 PICKUP	Sens. Gnd Fault	1A	0.05 .. 35.00 A	10.00 A	50Ns-2 Pickup
			5A	0.25 .. 175.00 A	50.00 A	
3114	50Ns-2 DELAY	Sens. Gnd Fault		0.00 .. 320.00 sec; ∞	1.00 sec	50Ns-2 Time Delay
3115	67Ns-2 DIRECT	Sens. Gnd Fault		Forward Reverse Non-Directional	Forward	67Ns-2 Direction
3117	50Ns-1 PICKUP	Sens. Gnd Fault	1A	0.001 .. 1.600 A	0.100 A	50Ns-1 Pickup
			5A	0.005 .. 8.000 A	0.500 A	
3117	50Ns-1 PICKUP	Sens. Gnd Fault	1A	0.05 .. 35.00 A	2.00 A	50Ns-1 Pickup
			5A	0.25 .. 175.00 A	10.00 A	
3118	50Ns-1 DELAY	Sens. Gnd Fault		0.00 .. 320.00 sec; ∞	2.00 sec	50Ns-1 Time delay
3119	51Ns PICKUP	Sens. Gnd Fault	1A	0.001 .. 1.400 A	0.100 A	51Ns Pickup
			5A	0.005 .. 7.000 A	0.500 A	
3119	51Ns PICKUP	Sens. Gnd Fault	1A	0.05 .. 4.00 A	1.00 A	51Ns Pickup
			5A	0.25 .. 20.00 A	5.00 A	
3120	51NsTIME DIAL	Sens. Gnd Fault		0.10 .. 4.00 sec; ∞	1.00 sec	51Ns Time Dial
3121A	50Ns T DROP-OUT	Sens. Gnd Fault		0.00 .. 60.00 sec	0.00 sec	50Ns Drop-Out Time Delay
3122	67Ns-1 DIRECT.	Sens. Gnd Fault		Forward Reverse Non-Directional	Forward	67Ns-1 Direction
3123	RELEASE DIRECT.	Sens. Gnd Fault	1A	0.001 .. 1.200 A	0.010 A	Release directional element
			5A	0.005 .. 6.000 A	0.050 A	
3123	RELEASE DIRECT.	Sens. Gnd Fault	1A	0.05 .. 30.00 A	0.50 A	Release directional element
			5A	0.25 .. 150.00 A	2.50 A	
3124	PHI CORRECTION	Sens. Gnd Fault		-45.0 .. 45.0 °	0.0 °	Correction Angle for Dir. Determination
3125	MEAS. METHOD	Sens. Gnd Fault		COS φ SIN φ	COS φ	Measurement method for Direction
3126	RESET DELAY	Sens. Gnd Fault		0 .. 60 sec	1 sec	Reset Delay
3130	PU CRITERIA	Sens. Gnd Fault		Vgnd OR INs Vgnd AND INs	Vgnd OR INs	Sensitive Ground Fault PICKUP criteria
3131	M.of PU TD	Sens. Gnd Fault		1.00 .. 20.00 MofPU; ∞ 0.01 .. 999.00 TD		Multiples of PU Time-Dial
3150	50Ns-2 Vmin	Sens. Gnd Fault		0.4 .. 50.0 V	2.0 V	50Ns-2 minimum voltage
3150	50Ns-2 Vmin	Sens. Gnd Fault		10.0 .. 90.0 V	10.0 V	50Ns-2 minimum voltage
3151	50Ns-2 Phi	Sens. Gnd Fault		-180.0 .. 180.0 °	-90.0 °	50Ns-2 angle phi
3152	50Ns-2 DeltaPhi	Sens. Gnd Fault		0.0 .. 180.0 °	30.0 °	50Ns-2 angle delta phi
3153	50Ns-1 Vmin	Sens. Gnd Fault		0.4 .. 50.0 V	6.0 V	50Ns-1 minimum voltage
3153	50Ns-1 Vmin	Sens. Gnd Fault		10.0 .. 90.0 V	15.0 V	50Ns-1 minimum voltage
3154	50Ns-1 Phi	Sens. Gnd Fault		-180.0 .. 180.0 °	-160.0 °	50Ns-1 angle phi
3155	50Ns-1 DeltaPhi	Sens. Gnd Fault		0.0 .. 180.0 °	100.0 °	50Ns-1 angle delta phi
3160	α1 red.dir.area	Sens. Gnd Fault		1 .. 15 °	2 °	Alpha1 (reduction directional area)
3161	α2 red.dir.area	Sens. Gnd Fault		1 .. 15 °	2 °	Alpha2 (reduction directional area)
3301	INTERM.EF	Intermit. EF		OFF ON	OFF	Intermittent earth fault protection
3302	lie>	Intermit. EF	1A	0.05 .. 35.00 A	1.00 A	Pick-up value of interm. E/F stage
			5A	0.25 .. 175.00 A	5.00 A	
3302	lie>	Intermit. EF	1A	0.05 .. 35.00 A	1.00 A	Pick-up value of interm. E/F stage
			5A	0.25 .. 175.00 A	5.00 A	

Addr.	Parameter	Function	C	Setting Options	Default Setting	Comments
3302	lie>	Intermit. EF		0.005 .. 1.500 A	1.000 A	Pick-up value of interm. E/F stage
3303	T-det.ext.	Intermit. EF		0.00 .. 10.00 sec	0.10 sec	Detection extension time
3304	T-sum det.	Intermit. EF		0.00 .. 100.00 sec	20.00 sec	Sum of detection times
3305	T-reset	Intermit. EF		1 .. 600 sec	300 sec	Reset time
3306	Nos.det.	Intermit. EF		2 .. 10	3	No. of det. for start of int. E/F prot
3401	Dir. Interm. EF	Dir. Interm. EF		OFF ON ON with GF log Alarm Only	OFF	Dir. Intermittent earth fault protection
3402	Direction	Dir. Interm. EF		Forward Reverse	Forward	Direction to be protected
3403	No. of pulses	Dir. Interm. EF		2 .. 50	5	Pulse no. for detecting the interm. E/F
3404	Monitoring time	Dir. Interm. EF		0.04 .. 10.00 sec	2.00 sec	Monitoring time after pickup detected
3405	Vgnd> / 3V0>	Dir. Interm. EF		2.0 .. 100.0 V	20.0 V	Vgnd> measured / 3V0> calculated
3406	Pickup	Dir. Interm. EF		with Vgnd/3V0> with oper. dir.	with Vgnd/3V0>	Pickup of the function
4001	FCT 46	46 Negative Seq		OFF ON	OFF	46 Negative Sequence Protection
4002	46-1 PICKUP	46 Negative Seq	1A	0.05 .. 3.00 A	0.10 A	46-1 Pickup
			5A	0.25 .. 15.00 A	0.50 A	
4003	46-1 DELAY	46 Negative Seq		0.00 .. 60.00 sec; ∞	1.50 sec	46-1 Time Delay
4004	46-2 PICKUP	46 Negative Seq	1A	0.05 .. 3.00 A	0.50 A	46-2 Pickup
			5A	0.25 .. 15.00 A	2.50 A	
4005	46-2 DELAY	46 Negative Seq		0.00 .. 60.00 sec; ∞	1.50 sec	46-2 Time Delay
4006	46 IEC CURVE	46 Negative Seq		Normal Inverse Very Inverse Extremely Inv.	Extremely Inv.	IEC Curve
4007	46 ANSI CURVE	46 Negative Seq		Extremely Inv. Inverse Moderately Inv. Very Inverse	Extremely Inv.	ANSI Curve
4008	46-TOC PICKUP	46 Negative Seq	1A	0.05 .. 2.00 A	0.90 A	46-TOC Pickup
			5A	0.25 .. 10.00 A	4.50 A	
4009	46-TOC TIMEDIAL	46 Negative Seq		0.50 .. 15.00 ; ∞	5.00	46-TOC Time Dial
4010	46-TOC TIMEDIAL	46 Negative Seq		0.05 .. 3.20 sec; ∞	0.50 sec	46-TOC Time Dial
4011	46-TOC RESET	46 Negative Seq		Instantaneous Disk Emulation	Instantaneous	46-TOC Drop Out
4012A	46 T DROP-OUT	46 Negative Seq		0.00 .. 60.00 sec	0.00 sec	46 Drop-Out Time Delay
4201	FCT 49	49 Th.Overload		OFF ON Alarm Only	OFF	49 Thermal overload protection
4202	49 K-FACTOR	49 Th.Overload		0.10 .. 4.00	1.10	49 K-Factor
4203	TIME CONSTANT	49 Th.Overload		1.0 .. 999.9 min	100.0 min	Time Constant
4204	49 Θ ALARM	49 Th.Overload		50 .. 100 %	90 %	49 Thermal Alarm Stage
4205	I ALARM	49 Th.Overload	1A	0.10 .. 4.00 A	1.00 A	Current Overload Alarm Setpoint
			5A	0.50 .. 20.00 A	5.00 A	
4207A	Kτ-FACTOR	49 Th.Overload		1.0 .. 10.0	1.0	Kτ-FACTOR when motor stops
4208A	T EMERGENCY	49 Th.Overload		10 .. 15000 sec	100 sec	Emergency time
5001	FCT 59	27/59 O/U Volt.		OFF ON Alarm Only	OFF	59 Overvoltage Protection
5001	FCT 59	27/59 O/U Volt.		OFF ON Alarm Only	ON	59 Overvoltage Protection (For CEI 0-16)
5002	59-1 PICKUP	27/59 O/U Volt.		20 .. 260 V	110 V	59-1 Pickup
5003	59-1 PICKUP	27/59 O/U Volt.		20 .. 150 V	110 V	59-1 Pickup
5004	59-1 DELAY	27/59 O/U Volt.		0.00 .. 100.00 sec; ∞	0.50 sec	59-1 Time Delay
5005	59-2 PICKUP	27/59 O/U Volt.		20 .. 260 V	120 V	59-2 Pickup

Appendix
A.8 Settings

Addr.	Parameter	Function	C	Setting Options	Default Setting	Comments
5006	59-2 PICKUP	27/59 O/U Volt.		20 .. 150 V	120 V	59-2 Pickup
5007	59-2 DELAY	27/59 O/U Volt.		0.00 .. 100.00 sec; ∞	0.50 sec	59-2 Time Delay
5015	59-1 PICKUP V2	27/59 O/U Volt.		2 .. 150 V	30 V	59-1 Pickup V2
5016	59-2 PICKUP V2	27/59 O/U Volt.		2 .. 150 V	50 V	59-2 Pickup V2
5017A	59-1 DOUT RATIO	27/59 O/U Volt.		0.90 .. 0.99	0.95	59-1 Dropout Ratio
5018A	59-2 DOUT RATIO	27/59 O/U Volt.		0.90 .. 0.99	0.95	59-2 Dropout Ratio
5019	59-1 PICKUP V1	27/59 O/U Volt.		20 .. 150 V	110 V	59-1 Pickup V1
5020	59-2 PICKUP V1	27/59 O/U Volt.		20 .. 150 V	120 V	59-2 Pickup V1
5030	59.S1 PICKUP	27/59 O/U Volt.		0.20 .. 1.50Un	1.10Un	59.S1 Pickup
5032A	59.S1 D-RATIO	27/59 O/U Volt.		0.90 .. 0.99	0.96	59.S1 Dropout Ratio
5034	59.S2 PICKUP	27/59 O/U Volt.		0.20 .. 1.50Un	1.20Un	59.S2 Pickup
5035	59.S2 Opert. T	27/59 O/U Volt.		0.05 .. 100.00 sec; ∞	0.60 sec	59.S2 Operation Time
5036A	59.S2 D-RATIO	27/59 O/U Volt.		0.90 .. 0.99	0.96	59.S2 Dropout Ratio
5101	FCT 27	27/59 O/U Volt.		OFF ON Alarm Only	OFF	27 Undervoltage Protection
5101	FCT 27	27/59 O/U Volt.		OFF ON Alarm Only	ON	27 Undervoltage Protection (For CEI 0-16)
5102	27-1 PICKUP	27/59 O/U Volt.		10 .. 210 V	75 V	27-1 Pickup
5103	27-1 PICKUP	27/59 O/U Volt.		10 .. 120 V	45 V	27-1 Pickup
5106	27-1 DELAY	27/59 O/U Volt.		0.00 .. 100.00 sec; ∞	1.50 sec	27-1 Time Delay
5110	27-2 PICKUP	27/59 O/U Volt.		10 .. 210 V	70 V	27-2 Pickup
5111	27-2 PICKUP	27/59 O/U Volt.		10 .. 120 V	40 V	27-2 Pickup
5112	27-2 DELAY	27/59 O/U Volt.		0.00 .. 100.00 sec; ∞	0.50 sec	27-2 Time Delay
5113A	27-1 DOUT RATIO	27/59 O/U Volt.		1.01 .. 3.00	1.20	27-1 Dropout Ratio
5114A	27-2 DOUT RATIO	27/59 O/U Volt.		1.01 .. 3.00	1.20	27-2 Dropout Ratio
5120A	CURRENT SUPERV.	27/59 O/U Volt.		OFF ON	ON	Current Supervision
5130	27.S1 PICKUP	27/59 O/U Volt.		0.10 .. 1.20Un	0.85Un	27.S1 Pickup
5131	27.S1 Opert. T	27/59 O/U Volt.		0.05 .. 100.00 sec; ∞	1.50 sec	27.S1 Operation Time
5132A	27.S1 D-RATIO	27/59 O/U Volt.		1.01 .. 3.00	1.04	27.S1 Dropout Ratio
5134	27.S2 PICKUP	27/59 O/U Volt.		0.10 .. 1.20Un	0.30Un	27.S2 Pickup
5135	27.S2 Opert. T	27/59 O/U Volt.		0.05 .. 100.00 sec; ∞	0.20 sec	27.S2 Operation Time
5136A	27.S2 D-RATIO	27/59 O/U Volt.		1.01 .. 3.00	1.04	27.S2 Dropout Ratio
5201	VT BROKEN WIRE	Measur. Superv		ON OFF	OFF	VT broken wire supervision
5202	Σ V>	Measur. Superv		1.0 .. 100.0 V	8.0 V	Threshold voltage sum
5203	Vph-ph max<	Measur. Superv		1.0 .. 100.0 V	16.0 V	Maximum phase to phase voltage
5204	Vph-ph min<	Measur. Superv		1.0 .. 100.0 V	16.0 V	Minimum phase to phase voltage
5205	Vph-ph max-min>	Measur. Superv		10.0 .. 200.0 V	16.0 V	Symmetry phase to phase voltages
5206	I min>	Measur. Superv	1A 5A	0.04 .. 1.00 A 0.20 .. 5.00 A	0.04 A 0.20 A	Minimum line current
5208	T DELAY ALARM	Measur. Superv		0.00 .. 32.00 sec	1.25 sec	Alarm delay time
5301	FUSE FAIL MON.	Measur. Superv		OFF Solid grounded Coil.gnd./isol.	OFF	Fuse Fail Monitor
5302	FUSE FAIL 3Vo	Measur. Superv		10 .. 100 V	30 V	Zero Sequence Voltage
5303	FUSE FAIL RESID	Measur. Superv	1A 5A	0.10 .. 1.00 A 0.50 .. 5.00 A	0.10 A 0.50 A	Residual Current
5308A	FFM Idiff (3ph)	Measur. Superv	1A 5A	0.05 .. 1.00 A 0.25 .. 5.00 A	0.10 A 0.50 A	Differential Current Threshold (3phase)
5310	BLOCK PROT.	Measur. Superv		NO YES	YES	Block protection by FFM
5401	FCT 81 O/U	81 O/U Freq.		OFF ON	OFF	81 Over/Under Frequency Protection

Addr.	Parameter	Function	C	Setting Options	Default Setting	Comments
5401	FCT 81 O/U	81 O/U Freq.		OFF ON	ON	81 Over/Under Frequency Protection (For CEI 0-16)
5402	Vmin	81 O/U Freq.		10 .. 150 V	65 V	Minimum required voltage for operation
5402	Vmin	81 O/U Freq.		20 .. 150 V	35 V	Minimum required voltage for operation
5403	81-1 PICKUP	81 O/U Freq.		40.00 .. 60.00 Hz	49.50 Hz	81-1 Pickup
5404	81-1 PICKUP	81 O/U Freq.		50.00 .. 70.00 Hz	59.50 Hz	81-1 Pickup
5405	81-1 DELAY	81 O/U Freq.		0.00 .. 100.00 sec; ∞	60.00 sec	81-1 Time Delay
5406	81-2 PICKUP	81 O/U Freq.		40.00 .. 60.00 Hz	49.00 Hz	81-2 Pickup
5407	81-2 PICKUP	81 O/U Freq.		50.00 .. 70.00 Hz	59.00 Hz	81-2 Pickup
5408	81-2 DELAY	81 O/U Freq.		0.00 .. 100.00 sec; ∞	30.00 sec	81-2 Time Delay
5409	81-3 PICKUP	81 O/U Freq.		40.00 .. 60.00 Hz	47.50 Hz	81-3 Pickup
5410	81-3 PICKUP	81 O/U Freq.		50.00 .. 70.00 Hz	57.50 Hz	81-3 Pickup
5411	81-3 DELAY	81 O/U Freq.		0.00 .. 100.00 sec; ∞	3.00 sec	81-3 Time delay
5412	81-4 PICKUP	81 O/U Freq.		40.00 .. 60.00 Hz	51.00 Hz	81-4 Pickup
5413	81-4 PICKUP	81 O/U Freq.		50.00 .. 70.00 Hz	61.00 Hz	81-4 Pickup
5414	81-4 DELAY	81 O/U Freq.		0.00 .. 100.00 sec; ∞	30.00 sec	81-4 Time delay
5415A	DO differential	81 O/U Freq.		0.02 .. 1.00 Hz	0.02 Hz	Dropout differential
5421	FCT 81-1 O/U	81 O/U Freq.		OFF ON f> ON f<	OFF	81-1 Over/Under Frequency Protection
5422	FCT 81-2 O/U	81 O/U Freq.		OFF ON f> ON f<	OFF	81-2 Over/Under Frequency Protection
5423	FCT 81-3 O/U	81 O/U Freq.		OFF ON f> ON f<	OFF	81-3 Over/Under Frequency Protection
5424	FCT 81-4 O/U	81 O/U Freq.		OFF ON f> ON f<	OFF	81-4 Over/Under Frequency Protection
5430	FCT 81>.S1	81 O/U Freq.		OFF ON	ON	81 S1 Over Frequency Protection
5431	FCT 81<.S1	81 O/U Freq.		OFF ON	ON	81 S1 Under Frequency Protection
5432	FCT 81>.S2	81 O/U Freq.		OFF ON	ON	81 S2 Over Frequency Protection
5433	FCT 81<.S2	81 O/U Freq.		OFF ON	ON	81 S2 Under Frequency Protection
5435A	Vmin	81 O/U Freq.		0.20 .. 1.50 Un	0.20 Un	Minimum required voltage for operation
5436A	DO differential	81 O/U Freq.		0.02 .. 1.00 Hz	0.10 Hz	Dropout Differential
5437A	Accel. Act. T	81 O/U Freq.		0.00 .. 60.00 sec	30.00 sec	Active Time of Accelerating Function
5438A	Accel. Oper. T	81 O/U Freq.		0.05 .. 5.00 sec	0.20 sec	Accelerated Operating Time
5439	81>.S1 PICKUP	81 O/U Freq.		50.00 .. 60.00 Hz	50.20 Hz	81>.S1 Pickup
5440	81>.S1 PICKUP	81 O/U Freq.		60.00 .. 70.00 Hz	60.20 Hz	81>.S1 Pickup
5441	81>.S1 Oper. T	81 O/U Freq.		0.05 .. 100.00 sec;∞	0.15 sec	81>.S1 Operating Time
5443	81<.S1 PICKUP	81 O/U Freq.		40.00 .. 50.00 Hz	49.80 Hz	81<.S1 Pickup
5444	81<.S1 PICKUP	81 O/U Freq.		50.00 .. 60.00 Hz	59.80 Hz	81<.S1 Pickup
5445	81<.S1 Oper. T	81 O/U Freq.		0.05 .. 100.00 sec;∞	0.15 sec	81<.S1 Operating Time
5447	81>.S2 PICKUP	81 O/U Freq.		50.00 .. 60.00 Hz	51.50 Hz	81>.S2 Pickup
5448	81>.S2 PICKUP	81 O/U Freq.		60.00 .. 70.00 Hz	61.50 Hz	81>.S2 Pickup
5449	81>.S2 Oper. T	81 O/U Freq.		0.05 .. 100.00 sec; ∞	1.00 sec	81>.S2 Operating Time
5451	81<.S2 PICKUP	81 O/U Freq.		40.00 .. 50.00 Hz	47.50 Hz	81<.S2 Pickup
5452	81<.S2 PICKUP	81 O/U Freq.		50.00 .. 60.00 Hz	57.50 Hz	81<.S2 Pickup
5453	81<.S2 Oper. T	81 O/U Freq.		0.05 .. 100.00 sec;∞	4.00 sec	81<.S2 Operating Time
5456	59V0 PICKUP	81 O/U Freq.		0.01 .. 1.15 Uen	0.05 Uen	59V0 Pickup
5457	59V0 Oper. T	81 O/U Freq.		0.05 .. 100.00 sec;∞	25.00 sec	59V0 Operating Time
5458A	59V0 D-RATIO	81 O/U Freq.		0.90 .. 0.99	0.96	59V0 Dropout Ratio

Appendix
A.8 Settings

Addr.	Parameter	Function	C	Setting Options	Default Setting	Comments
5460	81V 27V1 PICKUP	81 O/U Freq.		0.10 .. 1.20 Uphn	0.70 Uphn	81V 27V1 Pickup
5461A	81V 27V1 DO	81 O/U Freq.		1.01 .. 3.00	1.04	81V 27V1 Dropout Ratio
5462	81V 59V2 PICKUP	81 O/U Freq.		0.02 .. 1.50 Uphn	0.15 Uphn	81V 59V2 Pickup
5463A	81V 59V2 DO	81 O/U Freq.		0.90 .. 0.99	0.96	81V 59V2 Dropout Ratio
5464A	81V Rst T1 59V0	81 O/U Freq.		0.00 .. 0.20 sec	0.20 sec	81V Reset Time 1 for 59V0
5465A	81V Rst T2 81V	81 O/U Freq.		1.00 .. 240.00 sec	30.00 sec	81V Reset Time 2 for volt release
5466	59V0	81 O/U Freq.		OFF ON	ON	59V0 Zero sequence overvoltage
5501	27/Q-Protection	27/Q		OFF ON	OFF	27 / Q dir. con. Protection
5502	I-Release	27/Q	1A	0.02 .. 0.20 A	0.10 A	Current-Rel. for Trip and Reclose
			5A	0.10 .. 1.00 A	0.50 A	
5503	Inrush blk	27/Q		NO YES	NO	blocking with inrush
5511	Q> Pickup	27/Q	1A	1.70 .. 10000.00 VAR	8.70 VAR	Reactive power threshold for pickup
			5A	8.50 .. 50000.00 VAR	43.50 VAR	
5512	U< Pickup	27/Q		10.00 .. 210.00 V	85.00 V	Undervoltage threshold for pickup
5513	Delay Gen. CB	27/Q		0.00 .. 60.00 sec	0.50 sec	Trip time delay generator CB
5514	Delay Grid CB	27/Q		0.00 .. 60.00 sec	1.50 sec	Trip time delay grid CB
5521	Recl. release	27/Q		OFF ON	OFF	Reclosure release
5522	U> Reclose	27/Q		10.00 .. 210.00 V	95.00 V	Voltage threshold for reclosure rel.
5523	T Reclose	27/Q		0.00 .. 3600.00 sec	0.00 sec	Reclosure Delay Time
5524	Pos. f-diff	27/Q		0.01 .. 5.00 Hz	0.05 Hz	Pos. f-diff threshold for reclosure rel.
5525	Neg. f-diff	27/Q		-5.00 .. -0.01 Hz	-2.50 Hz	Neg. f-diff threshold for reclosure rel.
5526A	Incl. 27/Q Trip	27/Q		NO YES	NO	Include 27/Q Trip for reclosure rel.
6001	S1: RE/RL	P.System Data 2		-0.33 .. 7.00	1.00	S1: Zero seq. compensating factor RE/RL
6002	S1: XE/XL	P.System Data 2		-0.33 .. 7.00	1.00	S1: Zero seq. compensating factor XE/XL
6003	S1: x'	P.System Data 2	1A	0.0050 .. 15.0000 Ω/mi	0.2420 Ω/mi	S1: feeder reactance per mile: x'
			5A	0.0010 .. 3.0000 Ω/mi	0.0484 Ω/mi	
6004	S1: x'	P.System Data 2	1A	0.0050 .. 9.5000 Ω/km	0.1500 Ω/km	S1: feeder reactance per km: x'
			5A	0.0010 .. 1.9000 Ω/km	0.0300 Ω/km	
6005	S1: Line angle	P.System Data 2		10 .. 89 °	85 °	S1: Line angle
6006	S1: Line length	P.System Data 2		0.1 .. 650.0 Miles	62.1 Miles	S1: Line length in miles
6007	S1: Line length	P.System Data 2		0.1 .. 1000.0 km	100.0 km	S1: Line length in kilometer
6011	S2: RE/RL	P.System Data 2		-0.33 .. 7.00	1.00	S2: Zero seq. compensating factor RE/RL
6012	S2: XE/XL	P.System Data 2		-0.33 .. 7.00	1.00	S2: Zero seq. compensating factor XE/XL
6013	S2: x'	P.System Data 2	1A	0.0050 .. 15.0000 Ω/mi	0.2420 Ω/mi	S2: feeder reactance per mile: x'
			5A	0.0010 .. 3.0000 Ω/mi	0.0484 Ω/mi	
6014	S2: x'	P.System Data 2	1A	0.0050 .. 9.5000 Ω/km	0.1500 Ω/km	S2: feeder reactance per km: x'
			5A	0.0010 .. 1.9000 Ω/km	0.0300 Ω/km	
6015	S2: Line angle	P.System Data 2		10 .. 89 °	85 °	S2: Line angle
6016	S2: Line length	P.System Data 2		0.1 .. 650.0 Miles	62.1 Miles	S2: Line length in miles
6017	S2: Line length	P.System Data 2		0.1 .. 1000.0 km	100.0 km	S2: Line length in kilometer
6021	S3: RE/RL	P.System Data 2		-0.33 .. 7.00	1.00	S3: Zero seq. compensating factor RE/RL
6022	S3: XE/XL	P.System Data 2		-0.33 .. 7.00	1.00	S3: Zero seq. compensating factor XE/XL
6023	S3: x'	P.System Data 2	1A	0.0050 .. 15.0000 Ω/mi	0.2420 Ω/mi	S3: feeder reactance per mile: x'
			5A	0.0010 .. 3.0000 Ω/mi	0.0484 Ω/mi	

Addr.	Parameter	Function	C	Setting Options	Default Setting	Comments
6024	S3: x'	P.System Data 2	1A	0.0050 .. 9.5000 Ω/km	0.1500 Ω/km	S3: feeder reactance per km: x'
			5A	0.0010 .. 1.9000 Ω/km	0.0300 Ω/km	
6025	S3: Line angle	P.System Data 2		10 .. 89 °	85 °	S3: Line angle
6026	S3: Line length	P.System Data 2		0.1 .. 650.0 Miles	62.1 Miles	S3: Line length in miles
6027	S3: Line length	P.System Data 2		0.1 .. 1000.0 km	100.0 km	S3: Line length in kilometer
6101	Synchronizing	SYNC function 1		ON OFF	OFF	Synchronizing Function
6102	SyncCB	SYNC function 1		(Setting options depend on configuration)	None	Synchronizable circuit breaker
6103	Vmin	SYNC function 1		20 .. 125 V	90 V	Minimum voltage limit: Vmin
6104	Vmax	SYNC function 1		20 .. 140 V	110 V	Maximum voltage limit: Vmax
6105	V<	SYNC function 1		1 .. 60 V	5 V	Threshold V1, V2 without voltage
6106	V>	SYNC function 1		20 .. 140 V	80 V	Threshold V1, V2 with voltage
6107	SYNC V1<V2>	SYNC function 1		YES NO	NO	ON-Command at V1< and V2>
6108	SYNC V1>V2<	SYNC function 1		YES NO	NO	ON-Command at V1> and V2<
6109	SYNC V1<V2<	SYNC function 1		YES NO	NO	ON-Command at V1< and V2<
6110A	Direct CO	SYNC function 1		YES NO	NO	Direct ON-Command
6111A	TSUP VOLTAGE	SYNC function 1		0.00 .. 60.00 sec	0.10 sec	Supervision time of V1>;V2> or V1<;V2<
6112	T-SYN. DURATION	SYNC function 1		0.01 .. 1200.00 sec; ∞	30.00 sec	Maximum duration of Synchronization
6113A	25 Synchron	SYNC function 1		YES NO	YES	Switching at synchronous condition
6121	Balancing V1/V2	SYNC function 1		0.50 .. 2.00	1.00	Balancing factor V1/V2
6122A	ANGLE ADJUSTM.	SYNC function 1		0 .. 360 °	0 °	Angle adjustment (transformer)
6123	CONNECTIONof V2	SYNC function 1		A-B B-C C-A	A-B	Connection of V2
6125	VT Vn2, primary	SYNC function 1		0.10 .. 800.00 kV	20.00 kV	VT nominal voltage V2, primary
6150	dV SYNCHK V2>V1	SYNC function 1		0.5 .. 50.0 V	5.0 V	Maximum voltage difference V2>V1
6151	dV SYNCHK V2<V1	SYNC function 1		0.5 .. 50.0 V	5.0 V	Maximum voltage difference V2<V1
6152	df SYNCHK f2>f1	SYNC function 1		0.01 .. 2.00 Hz	0.10 Hz	Maximum frequency difference f2>f1
6153	df SYNCHK f2<f1	SYNC function 1		0.01 .. 2.00 Hz	0.10 Hz	Maximum frequency difference f2<f1
6154	dα SYNCHK α2>α1	SYNC function 1		2 .. 80 °	10 °	Maximum angle difference alpha2>alpha1
6155	dα SYNCHK α2<α1	SYNC function 1		2 .. 80 °	10 °	Maximum angle difference alpha2<alpha1
7001	FCT 50BF	50BF BkrFailure		OFF ON	OFF	50BF Breaker Failure Protection
7004	Chk BRK CONTACT	50BF BkrFailure		OFF ON	OFF	Check Breaker contacts
7005	TRIP-Timer	50BF BkrFailure		0.06 .. 60.00 sec; ∞	0.25 sec	TRIP-Timer
7006	50BF PICKUP	50BF BkrFailure	1A	0.05 .. 20.00 A	0.10 A	50BF Pickup current threshold
			5A	0.25 .. 100.00 A	0.50 A	
7007	50BF PICKUP IE>	50BF BkrFailure	1A	0.05 .. 20.00 A	0.10 A	50BF Pickup earth current threshold
			5A	0.25 .. 100.00 A	0.50 A	
7101	FCT 79	79M Auto Recl.		OFF ON	OFF	79 Auto-Reclose Function
7103	BLOCK MC Dur.	79M Auto Recl.		0.50 .. 320.00 sec; 0	1.00 sec	AR blocking duration after manual close
7105	TIME RESTRAINT	79M Auto Recl.		0.50 .. 320.00 sec	3.00 sec	79 Auto Reclosing reset time
7108	SAFETY 79 ready	79M Auto Recl.		0.01 .. 320.00 sec	0.50 sec	Safety Time until 79 is ready
7113	CHECK CB?	79M Auto Recl.		No check Chk each cycle	No check	Check circuit breaker before AR?

Appendix
A.8 Settings

Addr.	Parameter	Function	C	Setting Options	Default Setting	Comments
7114	T-Start MONITOR	79M Auto Recl.		0.01 .. 320.00 sec; ∞	0.50 sec	AR start-signal monitoring time
7115	CB TIME OUT	79M Auto Recl.		0.10 .. 320.00 sec	3.00 sec	Circuit Breaker (CB) Supervision Time
7116	Max. DEAD EXT.	79M Auto Recl.		0.50 .. 1800.00 sec; ∞	100.00 sec	Maximum dead time extension
7117	T-ACTION	79M Auto Recl.		0.01 .. 320.00 sec; ∞	∞ sec	Action time
7118	T DEAD DELAY	79M Auto Recl.		0.0 .. 1800.0 sec; ∞	1.0 sec	Maximum Time Delay of Dead-Time Start
7127	DEADTIME 1: PH	79M Auto Recl.		0.01 .. 320.00 sec	0.50 sec	Dead Time 1: Phase Fault
7128	DEADTIME 1: G	79M Auto Recl.		0.01 .. 320.00 sec	0.50 sec	Dead Time 1: Ground Fault
7129	DEADTIME 2: PH	79M Auto Recl.		0.01 .. 320.00 sec	0.50 sec	Dead Time 2: Phase Fault
7130	DEADTIME 2: G	79M Auto Recl.		0.01 .. 320.00 sec	0.50 sec	Dead Time 2: Ground Fault
7131	DEADTIME 3: PH	79M Auto Recl.		0.01 .. 320.00 sec	0.50 sec	Dead Time 3: Phase Fault
7132	DEADTIME 3: G	79M Auto Recl.		0.01 .. 320.00 sec	0.50 sec	Dead Time 3: Ground Fault
7133	DEADTIME 4: PH	79M Auto Recl.		0.01 .. 320.00 sec	0.50 sec	Dead Time 4: Phase Fault
7134	DEADTIME 4: G	79M Auto Recl.		0.01 .. 320.00 sec	0.50 sec	Dead Time 4: Ground Fault
7135	# OF RECL. GND	79M Auto Recl.		0 .. 9	1	Number of Reclosing Cycles Ground
7136	# OF RECL. PH	79M Auto Recl.		0 .. 9	1	Number of Reclosing Cycles Phase
7137	Cmd.via control	79M Auto Recl.		(Setting options depend on configuration)	None	Close command via control device
7138	Internal SYNC	79M Auto Recl.		(Setting options depend on configuration)	None	Internal 25 synchronisation
7139	External SYNC	79M Auto Recl.		YES NO	NO	External 25 synchronisation
7140	ZONE SEQ.COORD.	79M Auto Recl.		OFF ON	OFF	ZSC - Zone sequence coordination
7150	50-1	79M Auto Recl.		No influence Starts 79 Stops 79	No influence	50-1
7151	50N-1	79M Auto Recl.		No influence Starts 79 Stops 79	No influence	50N-1
7152	50-2	79M Auto Recl.		No influence Starts 79 Stops 79	No influence	50-2
7153	50N-2	79M Auto Recl.		No influence Starts 79 Stops 79	No influence	50N-2
7154	51	79M Auto Recl.		No influence Starts 79 Stops 79	No influence	51
7155	51N	79M Auto Recl.		No influence Starts 79 Stops 79	No influence	51N
7156	67-1	79M Auto Recl.		No influence Starts 79 Stops 79	No influence	67-1
7157	67N-1	79M Auto Recl.		No influence Starts 79 Stops 79	No influence	67N-1
7158	67-2	79M Auto Recl.		No influence Starts 79 Stops 79	No influence	67-2
7159	67N-2	79M Auto Recl.		No influence Starts 79 Stops 79	No influence	67N-2
7160	67 TOC	79M Auto Recl.		No influence Starts 79 Stops 79	No influence	67 TOC
7161	67N TOC	79M Auto Recl.		No influence Starts 79 Stops 79	No influence	67N TOC
7162	sens Ground Fit	79M Auto Recl.		No influence Starts 79 Stops 79	No influence	(Sensitive) Ground Fault

Addr.	Parameter	Function	C	Setting Options	Default Setting	Comments
7163	46	79M Auto Recl.		No influence Starts 79 Stops 79	No influence	46
7164	BINARY INPUT	79M Auto Recl.		No influence Starts 79 Stops 79	No influence	Binary Input
7165	3Pol.PICKUP BLK	79M Auto Recl.		YES NO	NO	3 Pole Pickup blocks 79
7166	50-3	79M Auto Recl.		No influence Starts 79 Stops 79	No influence	50-3
7167	50N-3	79M Auto Recl.		No influence Starts 79 Stops 79	No influence	50N-3
7168	67-3	79M Auto Recl.		No influence Starts 79 Stops 79	No influence	67-3
7169	67N-3	79M Auto Recl.		No influence Starts 79 Stops 79	No influence	67N-3
7200	bef.1.Cy:50-1	79M Auto Recl.		Set value T=T instant. T=0 blocked T=∞	Set value T=T	before 1. Cycle: 50-1
7201	bef.1.Cy:50N-1	79M Auto Recl.		Set value T=T instant. T=0 blocked T=∞	Set value T=T	before 1. Cycle: 50N-1
7202	bef.1.Cy:50-2	79M Auto Recl.		Set value T=T instant. T=0 blocked T=∞	Set value T=T	before 1. Cycle: 50-2
7203	bef.1.Cy:50N-2	79M Auto Recl.		Set value T=T instant. T=0 blocked T=∞	Set value T=T	before 1. Cycle: 50N-2
7204	bef.1.Cy:51	79M Auto Recl.		Set value T=T instant. T=0 blocked T=∞	Set value T=T	before 1. Cycle: 51
7205	bef.1.Cy:51N	79M Auto Recl.		Set value T=T instant. T=0 blocked T=∞	Set value T=T	before 1. Cycle: 51N
7206	bef.1.Cy:67-1	79M Auto Recl.		Set value T=T instant. T=0 blocked T=∞	Set value T=T	before 1. Cycle: 67-1
7207	bef.1.Cy:67N-1	79M Auto Recl.		Set value T=T instant. T=0 blocked T=∞	Set value T=T	before 1. Cycle: 67N-1
7208	bef.1.Cy:67-2	79M Auto Recl.		Set value T=T instant. T=0 blocked T=∞	Set value T=T	before 1. Cycle: 67-2
7209	bef.1.Cy:67N-2	79M Auto Recl.		Set value T=T instant. T=0 blocked T=∞	Set value T=T	before 1. Cycle: 67N-2
7210	bef.1.Cy:67 TOC	79M Auto Recl.		Set value T=T instant. T=0 blocked T=∞	Set value T=T	before 1. Cycle: 67 TOC
7211	bef.1.Cy:67NTOC	79M Auto Recl.		Set value T=T instant. T=0 blocked T=∞	Set value T=T	before 1. Cycle: 67N TOC
7212	bef.2.Cy:50-1	79M Auto Recl.		Set value T=T instant. T=0 blocked T=∞	Set value T=T	before 2. Cycle: 50-1
7213	bef.2.Cy:50N-1	79M Auto Recl.		Set value T=T instant. T=0 blocked T=∞	Set value T=T	before 2. Cycle: 50N-1
7214	bef.2.Cy:50-2	79M Auto Recl.		Set value T=T instant. T=0 blocked T=∞	Set value T=T	before 2. Cycle: 50-2
7215	bef.2.Cy:50N-2	79M Auto Recl.		Set value T=T instant. T=0 blocked T=∞	Set value T=T	before 2. Cycle: 50N-2

Appendix
A.8 Settings

Addr.	Parameter	Function	C	Setting Options	Default Setting	Comments
7216	bef.2.Cy:51	79M Auto Recl.		Set value T=T instant. T=0 blocked T=∞	Set value T=T	before 2. Cycle: 51
7217	bef.2.Cy:51N	79M Auto Recl.		Set value T=T instant. T=0 blocked T=∞	Set value T=T	before 2. Cycle: 51N
7218	bef.2.Cy:67-1	79M Auto Recl.		Set value T=T instant. T=0 blocked T=∞	Set value T=T	before 2. Cycle: 67-1
7219	bef.2.Cy:67N-1	79M Auto Recl.		Set value T=T instant. T=0 blocked T=∞	Set value T=T	before 2. Cycle: 67N-1
7220	bef.2.Cy:67-2	79M Auto Recl.		Set value T=T instant. T=0 blocked T=∞	Set value T=T	before 2. Cycle: 67-2
7221	bef.2.Cy:67N-2	79M Auto Recl.		Set value T=T instant. T=0 blocked T=∞	Set value T=T	before 2. Cycle: 67N-2
7222	bef.2.Cy:67 TOC	79M Auto Recl.		Set value T=T instant. T=0 blocked T=∞	Set value T=T	before 2. Cycle: 67 TOC
7223	bef.2.Cy:67NTOC	79M Auto Recl.		Set value T=T instant. T=0 blocked T=∞	Set value T=T	before 2. Cycle: 67N TOC
7224	bef.3.Cy:50-1	79M Auto Recl.		Set value T=T instant. T=0 blocked T=∞	Set value T=T	before 3. Cycle: 50-1
7225	bef.3.Cy:50N-1	79M Auto Recl.		Set value T=T instant. T=0 blocked T=∞	Set value T=T	before 3. Cycle: 50N-1
7226	bef.3.Cy:50-2	79M Auto Recl.		Set value T=T instant. T=0 blocked T=∞	Set value T=T	before 3. Cycle: 50-2
7227	bef.3.Cy:50N-2	79M Auto Recl.		Set value T=T instant. T=0 blocked T=∞	Set value T=T	before 3. Cycle: 50N-2
7228	bef.3.Cy:51	79M Auto Recl.		Set value T=T instant. T=0 blocked T=∞	Set value T=T	before 3. Cycle: 51
7229	bef.3.Cy:51N	79M Auto Recl.		Set value T=T instant. T=0 blocked T=∞	Set value T=T	before 3. Cycle: 51N
7230	bef.3.Cy:67-1	79M Auto Recl.		Set value T=T instant. T=0 blocked T=∞	Set value T=T	before 3. Cycle: 67-1
7231	bef.3.Cy:67N-1	79M Auto Recl.		Set value T=T instant. T=0 blocked T=∞	Set value T=T	before 3. Cycle: 67N-1
7232	bef.3.Cy:67-2	79M Auto Recl.		Set value T=T instant. T=0 blocked T=∞	Set value T=T	before 3. Cycle: 67-2
7233	bef.3.Cy:67N-2	79M Auto Recl.		Set value T=T instant. T=0 blocked T=∞	Set value T=T	before 3. Cycle: 67N-2
7234	bef.3.Cy:67 TOC	79M Auto Recl.		Set value T=T instant. T=0 blocked T=∞	Set value T=T	before 3. Cycle: 67 TOC
7235	bef.3.Cy:67NTOC	79M Auto Recl.		Set value T=T instant. T=0 blocked T=∞	Set value T=T	before 3. Cycle: 67N TOC
7236	bef.4.Cy:50-1	79M Auto Recl.		Set value T=T instant. T=0 blocked T=∞	Set value T=T	before 4. Cycle: 50-1
7237	bef.4.Cy:50N-1	79M Auto Recl.		Set value T=T instant. T=0 blocked T=∞	Set value T=T	before 4. Cycle: 50N-1
7238	bef.4.Cy:50-2	79M Auto Recl.		Set value T=T instant. T=0 blocked T=∞	Set value T=T	before 4. Cycle: 50-2

Addr.	Parameter	Function	C	Setting Options	Default Setting	Comments
7239	bef.4.Cy:50N-2	79M Auto Recl.		Set value T=T instant. T=0 blocked T=∞	Set value T=T	before 4. Cycle: 50N-2
7240	bef.4.Cy:51	79M Auto Recl.		Set value T=T instant. T=0 blocked T=∞	Set value T=T	before 4. Cycle: 51
7241	bef.4.Cy:51N	79M Auto Recl.		Set value T=T instant. T=0 blocked T=∞	Set value T=T	before 4. Cycle: 51N
7242	bef.4.Cy:67-1	79M Auto Recl.		Set value T=T instant. T=0 blocked T=∞	Set value T=T	before 4. Cycle: 67-1
7243	bef.4.Cy:67N-1	79M Auto Recl.		Set value T=T instant. T=0 blocked T=∞	Set value T=T	before 4. Cycle: 67N-1
7244	bef.4.Cy:67-2	79M Auto Recl.		Set value T=T instant. T=0 blocked T=∞	Set value T=T	before 4. Cycle: 67-2
7245	bef.4.Cy:67N-2	79M Auto Recl.		Set value T=T instant. T=0 blocked T=∞	Set value T=T	before 4. Cycle: 67N-2
7246	bef.4.Cy:67 TOC	79M Auto Recl.		Set value T=T instant. T=0 blocked T=∞	Set value T=T	before 4. Cycle: 67 TOC
7247	bef.4.Cy:67NTOC	79M Auto Recl.		Set value T=T instant. T=0 blocked T=∞	Set value T=T	before 4. Cycle: 67N TOC
7248	bef.1.Cy:50-3	79M Auto Recl.		Set value T=T instant. T=0 blocked T=∞	Set value T=T	before 1. Cycle: 50-3
7249	bef.1.Cy:50N-3	79M Auto Recl.		Set value T=T instant. T=0 blocked T=∞	Set value T=T	before 1. Cycle: 50N-3
7250	bef.2.Cy:50-3	79M Auto Recl.		Set value T=T instant. T=0 blocked T=∞	Set value T=T	before 2. Cycle: 50-3
7251	bef.2.Cy:50N-3	79M Auto Recl.		Set value T=T instant. T=0 blocked T=∞	Set value T=T	before 2. Cycle: 50N-3
7252	bef.3.Cy:50-3	79M Auto Recl.		Set value T=T instant. T=0 blocked T=∞	Set value T=T	before 3. Cycle: 50-3
7253	bef.3.Cy:50N-3	79M Auto Recl.		Set value T=T instant. T=0 blocked T=∞	Set value T=T	before 3. Cycle: 50N-3
7254	bef.4.Cy:50-3	79M Auto Recl.		Set value T=T instant. T=0 blocked T=∞	Set value T=T	before 4. Cycle: 50-3
7255	bef.4.Cy:50N-3	79M Auto Recl.		Set value T=T instant. T=0 blocked T=∞	Set value T=T	before 4. Cycle: 50N-3
7256	bef.1.Cy:67-3	79M Auto Recl.		Set value T=T instant. T=0 blocked T=∞	Set value T=T	before 1. Cycle: 67-3
7257	bef.1.Cy:67N-3	79M Auto Recl.		Set value T=T instant. T=0 blocked T=∞	Set value T=T	before 1. Cycle: IE>>> directional
7258	bef.2.Cy:67-3	79M Auto Recl.		Set value T=T instant. T=0 blocked T=∞	Set value T=T	before 2. Cycle: 67-3
7259	bef.2.Cy:67N-3	79M Auto Recl.		Set value T=T instant. T=0 blocked T=∞	Set value T=T	before 2. Cycle: IE>>> directional
7260	bef.3.Cy:67-3	79M Auto Recl.		Set value T=T instant. T=0 blocked T=∞	Set value T=T	before 3. Cycle: 67-3
7261	bef.3.Cy:67N-3	79M Auto Recl.		Set value T=T instant. T=0 blocked T=∞	Set value T=T	before 3. Cycle: IE>>> directional

Appendix
A.8 Settings

Addr.	Parameter	Function	C	Setting Options	Default Setting	Comments
7262	bef.4.Cy:67-3	79M Auto Recl.		Set value T=T instant. T=0 blocked T=∞	Set value T=T	before 4. Cycle: 67-3
7263	bef.4.Cy:67N-3	79M Auto Recl.		Set value T=T instant. T=0 blocked T=∞	Set value T=T	before 4. Cycle: 67N-3
8001	START	Fault Locator		Pickup TRIP	Pickup	Start fault locator with
8101	MEASURE. SUPERV	Measurem.Superv		OFF ON	ON	Measurement Supervision
8101	MEASURE. SUPERV	Measurem.Superv		OFF ON	OFF	Measurement Supervision (For CEI 0-16)
8102	BALANCE V-LIMIT	Measurem.Superv		10 .. 100 V	50 V	Voltage Threshold for Balance Monitoring
8103	BAL. FACTOR V	Measurem.Superv		0.58 .. 0.90	0.75	Balance Factor for Voltage Monitor
8104	BALANCE I LIMIT	Measurem.Superv	1A	0.10 .. 1.00 A	0.50 A	Current Threshold for Balance Monitoring
			5A	0.50 .. 5.00 A	2.50 A	
8105	BAL. FACTOR I	Measurem.Superv		0.10 .. 0.90	0.50	Balance Factor for Current Monitor
8106	Σ I THRESHOLD	Measurem.Superv	1A	0.05 .. 2.00 A; ∞	0.10 A	Summated Current Monitoring Threshold
			5A	0.25 .. 10.00 A; ∞	0.50 A	
8107	Σ I FACTOR	Measurem.Superv		0.00 .. 0.95	0.10	Summated Current Monitoring Factor
8109	FAST Σ i MONIT	Measurem.Superv		OFF ON	ON	Fast Summated Current Monitoring
8110A	T BAL. V LIMIT	Measurem.Superv		0 .. 100 sec	5 sec	T Balance Factor for Voltage Monitor
8111A	T BAL. I LIMIT	Measurem.Superv		0 .. 100 sec	5 sec	T Current Balance Monitor
8201	FCT 74TC	74TC TripCirc.		ON OFF	ON	74TC TRIP Circuit Supervision
8202	Alarm Delay	74TC TripCirc.		1 .. 30 sec	2 sec	Delay Time for alarm
8301	DMD Interval	Demand meter		15 Min., 1 Sub 15 Min., 3 Subs 15 Min., 15 Subs 30 Min., 1 Sub 60 Min., 1 Sub 60 Min., 10 Subs 5 Min., 5 Subs	60 Min., 1 Sub	Demand Calculation Intervals
8302	DMD Sync.Time	Demand meter		On The Hour 15 After Hour 30 After Hour 45 After Hour	On The Hour	Demand Synchronization Time
8311	MinMax cycRESET	Min/Max meter		NO YES	YES	Automatic Cyclic Reset Function
8312	MiMa RESET TIME	Min/Max meter		0 .. 1439 min	0 min	MinMax Reset Timer
8313	MiMa RESETCYCLE	Min/Max meter		1 .. 365 Days	7 Days	MinMax Reset Cycle Period
8314	MinMaxRES.START	Min/Max meter		1 .. 365 Days	1 Days	MinMax Start Reset Cycle in
8315	MeterResolution	Energy		Standard Factor 10 Factor 100	Standard	Meter resolution

A.9 Information List

Indications for IEC 60 870-5-103 are always reported ON / OFF if they are subject to general interrogation for IEC 60 870-5-103. If not, they are reported only as ON.

New user-defined indications or such newly allocated to IEC 60 870-5-103 are set to ON / OFF and subjected to general interrogation if the information type is not a spontaneous event („...Ev“). Further information with regard to the indications is set out in the SIPROTEC 4 System Description, Order No. E50417-H1100-C151.

In columns „Event Log“, „Trip Log“ and „Ground Fault Log“ the following applies:

UPPER CASE NOTATION “ON/OFF”: definitely set, not allocatable

lower case notation “on/off”: preset, allocatable

*: not preset, allocatable

<blank>: neither preset nor allocatable

In the column „Marked in Oscill. Record“ the following applies:

UPPER CASE NOTATION “M”: definitely set, not allocatable

lower case notation “m”: preset, allocatable

*: not preset, allocatable

<blank>: neither preset nor allocatable

No.	Description	Function	Type of Information	Log Buffers				Configurable in Matrix					IEC 60870-5-103				
				Event Log ON/OFF	Trip (Fault) Log ON/OFF	Ground Fault Log ON/OFF	Marked in Oscill. Record	LED	Binary Input	Function Key	Relay	Chatter Suppression	Type	Information Number	Data Unit	General Interrogation	
-	>Back Light on (>Light on)	Device, General	SP	On Off	*		*	LED	BI		BO						
-	Reset LED (Reset LED)	Device, General	IntSP	on	*		*	LED			BO	160	19	1	No		
-	Stop data transmission (DataS-top)	Device, General	IntSP	On Off	*		*	LED			BO	160	20	1	Yes		
-	Test mode (Test mode)	Device, General	IntSP	On Off	*		*	LED			BO	160	21	1	Yes		
-	Feeder GROUNDED (Feeder gnd)	Device, General	IntSP	*	*		*	LED			BO						
-	Breaker OPENED (Brk OPENED)	Device, General	IntSP	*	*		*	LED			BO						
-	Hardware Test Mode (HWTest-Mod)	Device, General	IntSP	On Off	*		*	LED			BO						
-	Clock Synchronization (Synch-Clock)	Device, General	IntSP_Ev	*	*		*										
-	Disturbance CFC (Distur.CFC)	Device, General	OUT	On Off	*			LED			BO						
-	Fault Recording Start (FltRecSta)	Osc. Fault Rec.	IntSP	On Off	*		m	LED			BO						
-	Setting Group A is active (P-GrpA act)	Change Group	IntSP	On Off	*		*	LED			BO	160	23	1	Yes		
-	Setting Group B is active (P-GrpB act)	Change Group	IntSP	On Off	*		*	LED			BO	160	24	1	Yes		
-	Setting Group C is active (P-GrpC act)	Change Group	IntSP	On Off	*		*	LED			BO	160	25	1	Yes		
-	Setting Group D is active (P-GrpD act)	Change Group	IntSP	On Off	*		*	LED			BO	160	26	1	Yes		

Appendix
A.9 Information List

No.	Description	Function	Type of Information	Log Buffers				Configurable in Matrix				IEC 60870-5-103					
				Event Log ON/OFF	Trip (Fault) Log ON/OFF	Ground Fault Log ON/OFF	Marked in Oscill. Record	LED	Binary Input	Function Key	Relay	Chatter Suppression	Type	Information Number	Data Unit	General Interrogation	
-	Controlmode REMOTE (ModeREMOTE)	Cntrl Authority	IntSP	On Off	*			LED			BO						
-	Control Authority (Cntrl Auth)	Cntrl Authority	IntSP	On Off	*			LED			BO	101	85	1	Yes		
-	Controlmode LOCAL (ModeLOCAL)	Cntrl Authority	IntSP	On Off	*			LED			BO	101	86	1	Yes		
-	52 Breaker (52Breaker)	Control Device	CF_D12	On Off				LED			BO	240	160	20			
-	52 Breaker (52Breaker)	Control Device	DP	On Off					BI		CB	240	160	1	Yes		
-	Disconnect Switch (Disc.Swit.)	Control Device	CF_D2	On Off				LED			BO	240	161	20			
-	Disconnect Switch (Disc.Swit.)	Control Device	DP	On Off					BI		CB	240	161	1	Yes		
-	Ground Switch (GndSwit.)	Control Device	CF_D2	On Off				LED			BO	240	164	20			
-	Ground Switch (GndSwit.)	Control Device	DP	On Off					BI		CB	240	164	1	Yes		
-	>CB ready Spring is charged (>CB ready)	Process Data	SP	*	*		*	LED	BI		BO	CB					
-	>Door closed (>DoorClose)	Process Data	SP	*	*		*	LED	BI		BO	CB					
-	>Cabinet door open (>Door open)	Process Data	SP	On Off	*		*	LED	BI		BO	CB	101	1	1	Yes	
-	>CB waiting for Spring charged (>CB wait)	Process Data	SP	On Off	*		*	LED	BI		BO	CB	101	2	1	Yes	
-	>No Voltage (Fuse blown) (>No Volt.)	Process Data	SP	On Off	*		*	LED	BI		BO	CB	160	38	1	Yes	
-	>Error Motor Voltage (>Err Mot V)	Process Data	SP	On Off	*		*	LED	BI		BO	CB	240	181	1	Yes	
-	>Error Control Voltage (>ErrCntrlV)	Process Data	SP	On Off	*		*	LED	BI		BO	CB	240	182	1	Yes	
-	>SF6-Loss (>SF6-Loss)	Process Data	SP	On Off	*		*	LED	BI		BO	CB	240	183	1	Yes	
-	>Error Meter (>Err Meter)	Process Data	SP	On Off	*		*	LED	BI		BO	CB	240	184	1	Yes	
-	>Transformer Temperature (>Tx Temp.)	Process Data	SP	On Off	*		*	LED	BI		BO	CB	240	185	1	Yes	
-	>Transformer Danger (>Tx Danger)	Process Data	SP	On Off	*		*	LED	BI		BO	CB	240	186	1	Yes	
-	Reset Minimum and Maximum counter (ResMinMax)	Min/Max meter	IntSP_Ev	ON													
-	Reset meter (Meter res)	Energy	IntSP_Ev	ON					BI								
-	Error Systeminterface (SysIntErr.)	Protocol	IntSP	On Off	*	*		LED			BO						
-	DCP identify (DCP ident)	Protocol	IntSP	*	*	*		LED			BO						
-	Threshold Value 1 (ThreshVal1)	Thresh.-Switch	IntSP	On Off				LED		FC TN	BO	CB					
1	No Function configured (Not configured)	Device, General	SP	*	*												
2	Function Not Available (Non Existent)	Device, General	SP	*	*												
3	>Synchronize Internal Real Time Clock (>Time Synch)	Device, General	SP_Ev	*	*			LED	BI		BO	135	48	1	Yes		
4	>Trigger Waveform Capture (>Trig.Wave.Cap.)	Osc. Fault Rec.	SP	*	*		m	LED	BI		BO	135	49	1	Yes		

No.	Description	Function	Type of Information	Log Buffers				Configurable in Matrix					IEC 60870-5-103			
				Event Log ON/OFF	Trip (Fault) Log ON/OFF	Ground Fault Log ON/OFF	Marked in Oscill. Record	LED	Binary Input	Function Key	Relay	Chatter Suppression	Type	Information Number	Data Unit	General Interrogation
5	>Reset LED (>Reset LED)	Device, General	SP	*	*		*	LED	BI		BO		135	50	1	Yes
7	>Setting Group Select Bit 0 (>Set Group Bit0)	Change Group	SP	*	*		*	LED	BI		BO		135	51	1	Yes
8	>Setting Group Select Bit 1 (>Set Group Bit1)	Change Group	SP	*	*		*	LED	BI		BO		135	52	1	Yes
009.0100	Failure EN100 Modul (Failure Modul)	EN100-Modul 1	IntSP	On Off	*		*	LED			BO					
009.0101	Failure EN100 Link Channel 1 (Ch1) (Fail Ch1)	EN100-Modul 1	IntSP	On Off	*		*	LED			BO					
009.0102	Failure EN100 Link Channel 2 (Ch2) (Fail Ch2)	EN100-Modul 1	IntSP	On Off	*		*	LED			BO					
15	>Test mode (>Test mode)	Device, General	SP	*	*		*	LED	BI		BO		135	53	1	Yes
16	>Stop data transmission (>DataStop)	Device, General	SP	*	*		*	LED	BI		BO		135	54	1	Yes
51	Device is Operational and Protecting (Device OK)	Device, General	OUT	On Off	*		*	LED			BO		135	81	1	Yes
52	At Least 1 Protection Funct. is Active (ProtActive)	Device, General	IntSP	On Off	*		*	LED			BO		160	18	1	Yes
55	Reset Device (Reset Device)	Device, General	OUT	on	*		*						160	4	1	No
56	Initial Start of Device (Initial Start)	Device, General	OUT	on	*		*	LED			BO		160	5	1	No
67	Resume (Resume)	Device, General	OUT	on	*		*	LED			BO					
68	Clock Synchronization Error (Clock SyncError)	Device, General	OUT	On Off	*		*	LED			BO					
69	Daylight Saving Time (DayLight-SavTime)	Device, General	OUT	On Off	*		*	LED			BO					
70	Setting calculation is running (Settings Calc.)	Device, General	OUT	On Off	*		*	LED			BO		160	22	1	Yes
71	Settings Check (Settings Check)	Device, General	OUT	*	*		*	LED			BO					
72	Level-2 change (Level-2 change)	Device, General	OUT	On Off	*		*	LED			BO					
73	Local setting change (Local change)	Device, General	OUT	*	*		*									
110	Event lost (Event Lost)	Device, General	OUT_Ev	on	*			LED			BO		135	130	1	No
113	Flag Lost (Flag Lost)	Device, General	OUT	on	*		m	LED			BO		135	136	1	Yes
125	Chatter ON (Chatter ON)	Device, General	OUT	On Off	*		*	LED			BO		135	145	1	Yes
126	Protection ON/OFF (via system port) (ProtON/OFF)	P.System Data 2	IntSP	On Off	*		*	LED			BO					
127	79 ON/OFF (via system port) (79 ON/OFF)	79M Auto Recl.	IntSP	On Off	*		*	LED			BO					
140	Error with a summary alarm (Error Sum Alarm)	Device, General	OUT	On Off	*		*	LED			BO		160	47	1	Yes
160	Alarm Summary Event (Alarm Sum Event)	Device, General	OUT	On Off	*		*	LED			BO		160	46	1	Yes
161	Failure: General Current Supervision (Fail I Superv.)	Measurem.Superv	OUT	On Off	*		*	LED			BO		160	32	1	Yes
162	Failure: Current Summation (Failure Σ I)	Measurem.Superv	OUT	On Off	*		*	LED			BO		135	182	1	Yes
163	Failure: Current Balance (Fail I balance)	Measurem.Superv	OUT	On Off	*		*	LED			BO		135	183	1	Yes
167	Failure: Voltage Balance (Fail V balance)	Measurem.Superv	OUT	On Off	*		*	LED			BO		135	186	1	Yes
169	VT Fuse Failure (alarm >10s) (VT FuseFail>10s)	Measurem.Superv	OUT	On Off	*		*	LED			BO		135	188	1	Yes

No.	Description	Function	Type of Information	Log Buffers				Configurable in Matrix					IEC 60870-5-103				
				Event Log ON/OFF	Trip (Fault) Log ON/OFF	Ground Fault Log ON/OFF	Marked in Oscill. Record	LED	Binary Input	Function Key	Relay	Chatter Suppression	Type	Information Number	Data Unit	General Interrogation	
170	VT Fuse Failure (alarm instantaneous) (VT FuseFail)	Measurment.Superv	OUT	On Off	*		*	LED			BO						
170.0001	>25-group 1 activate (>25-1 act)	SYNC function 1	SP	On Off			*	LED	BI								
170.0043	>25 Synchronization request (>25 Sync requ.)	SYNC function 1	SP	On Off			*	LED	BI								
170.0049	25 Sync. Release of CLOSE Command (25 CloseRelease)	SYNC function 1	OUT	On Off			*	LED			BO	41	201	1	Yes		
170.0050	25 Synchronization Error (25 Sync. Error)	SYNC function 1	OUT	On Off			*	LED			BO	41	202	1	Yes		
170.0051	25-group 1 is BLOCKED (25-1 BLOCK)	SYNC function 1	OUT	On Off			*	LED			BO	41	204	1	Yes		
170.2007	25 Sync. Measuring request of Control (25 Measu. req.)	SYNC function 1	SP	On Off			*	LED									
170.2008	>BLOCK 25-group 1 (>BLK 25-1)	SYNC function 1	SP	On Off			*	LED	BI								
170.2009	>25 Direct Command output (>25direct CO)	SYNC function 1	SP	On Off			*	LED	BI								
170.2011	>25 Start of synchronization (>25 Start)	SYNC function 1	SP	On Off			*	LED	BI								
170.2012	>25 Stop of synchronizaiton (>25 Stop)	SYNC function 1	SP	On Off			*	LED	BI								
170.2013	>25 Switch to V1> and V2< (>25 V1>V2<)	SYNC function 1	SP	On Off			*	LED	BI								
170.2014	>25 Switch to V1< and V2> (>25 V1<V2>)	SYNC function 1	SP	On Off			*	LED	BI								
170.2015	>25 Switch to V1< and V2< (>25 V1<V2<)	SYNC function 1	SP	On Off			*	LED	BI								
170.2016	>25 Switch to Sync (>25 synchr.)	SYNC function 1	SP	On Off			*	LED	BI								
170.2022	25-group 1: measurement in progress (25-1 meas.)	SYNC function 1	OUT	On Off			*	LED			BO	41	203	1	Yes		
170.2025	25 Monitoring time exceeded (25 MonTimeExc)	SYNC function 1	OUT	On Off			*	LED			BO	41	205	1	Yes		
170.2026	25 Synchronization conditions okay (25 Synchron)	SYNC function 1	OUT	On Off			*	LED			BO	41	206	1	Yes		
170.2027	25 Condition V1>V2< fulfilled (25 V1> V2<)	SYNC function 1	OUT	On Off			*	LED			BO						
170.2028	25 Condition V1<V2> fulfilled (25 V1< V2>)	SYNC function 1	OUT	On Off			*	LED			BO						
170.2029	25 Condition V1<V2< fulfilled (25 V1< V2<)	SYNC function 1	OUT	On Off			*	LED			BO						
170.2030	25 Voltage difference (Vdiff) okay (25 Vdiff ok)	SYNC function 1	OUT	On Off			*	LED			BO	41	207	1	Yes		
170.2031	25 Frequency difference (fdiff) okay (25 fdiff ok)	SYNC function 1	OUT	On Off			*	LED			BO	41	208	1	Yes		
170.2032	25 Angle difference (alphadiff) okay (25 adiff ok)	SYNC function 1	OUT	On Off			*	LED			BO	41	209	1	Yes		
170.2033	25 Frequency f1 > fmax permissible (25 f1>>)	SYNC function 1	OUT	On Off			*	LED			BO						
170.2034	25 Frequency f1 < fmin permissible (25 f1<<)	SYNC function 1	OUT	On Off			*	LED			BO						
170.2035	25 Frequency f2 > fmax permissible (25 f2>>)	SYNC function 1	OUT	On Off			*	LED			BO						
170.2036	25 Frequency f2 < fmin permissible (25 f2<<)	SYNC function 1	OUT	On Off			*	LED			BO						

No.	Description	Function	Type of Information	Log Buffers			Configurable in Matrix					IEC 60870-5-103					
				Event Log ON/OFF	Trip (Fault) Log ON/OFF	Ground Fault Log ON/OFF	Marked in Oscill. Record	LED	Binary Input	Function Key	Relay	Chatter Suppression	Type	Information Number	Data Unit	General Interrogation	
170.2037	25 Voltage V1 > Vmax permissible (25 V1>>)	SYNC function 1	OUT	On Off			*	LED			BO						
170.2038	25 Voltage V1 < Vmin permissible (25 V1<<)	SYNC function 1	OUT	On Off			*	LED			BO						
170.2039	25 Voltage V2 > Vmax permissible (25 V2>>)	SYNC function 1	OUT	On Off			*	LED			BO						
170.2040	25 Voltage V2 < Vmin permissible (25 V2<<)	SYNC function 1	OUT	On Off			*	LED			BO						
170.2090	25 Vdiff too large (V2>V1) (25 V2>V1)	SYNC function 1	OUT	On Off			*	LED			BO						
170.2091	25 Vdiff too large (V2<V1) (25 V2<V1)	SYNC function 1	OUT	On Off			*	LED			BO						
170.2092	25 fdiff too large (f2>f1) (25 f2>f1)	SYNC function 1	OUT	On Off			*	LED			BO						
170.2093	25 fdiff too large (f2<f1) (25 f2<f1)	SYNC function 1	OUT	On Off			*	LED			BO						
170.2094	25 alphadiff too large (a2>a1) (25 α2>α1)	SYNC function 1	OUT	On Off			*	LED			BO						
170.2095	25 alphadiff too large (a2<a1) (25 α2<α1)	SYNC function 1	OUT	On Off			*	LED			BO						
170.2096	25 Multiple selection of func-groups (25 FG-Error)	SYNC function 1	OUT	On Off				LED			BO						
170.2097	25 Setting error (25 Set-Error)	SYNC function 1	OUT	On Off				LED			BO						
170.2101	Sync-group 1 is switched OFF (25-1 OFF)	SYNC function 1	OUT	On Off			*	LED			BO	41	36	1	Yes		
170.2102	>BLOCK 25 CLOSE command (>BLK 25 CLOSE)	SYNC function 1	SP	On Off			*	LED	BI								
170.2103	25 CLOSE command is BLOCKED (25 CLOSE BLK)	SYNC function 1	OUT	On Off			*	LED			BO	41	37	1	Yes		
171	Failure: Phase Sequence (Fail Ph. Seq.)	Measurem.Superv	OUT	On Off	*		*	LED			BO	160	35	1	Yes		
175	Failure: Phase Sequence Current (Fail Ph. Seq. I)	Measurem.Superv	OUT	On Off	*		*	LED			BO	135	191	1	Yes		
176	Failure: Phase Sequence Voltage (Fail Ph. Seq. V)	Measurem.Superv	OUT	On Off	*		*	LED			BO	135	192	1	Yes		
177	Failure: Battery empty (Fail Battery)	Device, General	OUT	On Off	*		*	LED			BO						
178	I/O-Board Error (I/O-Board error)	Device, General	OUT	On Off	*		*	LED			BO						
181	Error: A/D converter (Error A/D-conv.)	Device, General	OUT	On Off	*		*	LED			BO						
191	Error: Offset (Error Offset)	Device, General	OUT	On Off	*		*	LED			BO						
193	Alarm: NO calibration data available (Alarm NO calibr)	Device, General	OUT	On Off	*		*	LED			BO						
194	Error: Neutral CT different from MLFB (Error neutralCT)	Device, General	OUT	On Off	*												
197	Measurement Supervision is switched OFF (MeasSup OFF)	Measurem.Superv	OUT	On Off	*		*	LED			BO	135	197	1	Yes		
203	Waveform data deleted (Wave. deleted)	Osc. Fault Rec.	OUT_Ev	on	*			LED			BO	135	203	1	No		
232	LPCT phase Current Transf. mismatching (CT ph mismatch)	Device, General	OUT	On Off			*	LED			BO						
233	LPCT ground Current Transf. mismatching (CT gnd mismatch)	Device, General	OUT	On Off			*	LED			BO						

Appendix
A.9 Information List

No.	Description	Function	Type of Information	Log Buffers				Configurable in Matrix					IEC 60870-5-103				
				Event Log ON/OFF	Trip (Fault) Log ON/OFF	Ground Fault Log ON/OFF	Marked in Oscill. Record	LED	Binary Input	Function Key	Relay	Chatter Suppression	Type	Information Number	Data Unit	General Interrogation	
234.2100	27, 59 blocked via operation (27, 59 blk)	27/59 O/U Volt.	IntSP	On Off	*		*	LED			BO						
235.2110	>BLOCK Function \$00 (>BLOCK \$00)	Flx	SP	On Off	On Off	*	*	LED	BI	FC TN	BO						
235.2111	>Function \$00 instantaneous TRIP (>\$00 instant.)	Flx	SP	On Off	On Off	*	*	LED	BI	FC TN	BO						
235.2112	>Function \$00 Direct TRIP (>\$00 Dir.TRIP)	Flx	SP	On Off	On Off	*	*	LED	BI	FC TN	BO						
235.2113	>Function \$00 BLOCK TRIP Time Delay (>\$00 BLK.TDly)	Flx	SP	On Off	On Off	*	*	LED	BI	FC TN	BO						
235.2114	>Function \$00 BLOCK TRIP (>\$00 BLK.TRIP)	Flx	SP	On Off	On Off	*	*	LED	BI	FC TN	BO						
235.2115	>Function \$00 BLOCK TRIP Phase A (>\$00 BL.TripA)	Flx	SP	On Off	On Off	*	*	LED	BI	FC TN	BO						
235.2116	>Function \$00 BLOCK TRIP Phase B (>\$00 BL.TripB)	Flx	SP	On Off	On Off	*	*	LED	BI	FC TN	BO						
235.2117	>Function \$00 BLOCK TRIP Phase C (>\$00 BL.TripC)	Flx	SP	On Off	On Off	*	*	LED	BI	FC TN	BO						
235.2118	Function \$00 is BLOCKED (\$00 BLOCKED)	Flx	OUT	On Off	On Off	*	*	LED			BO						
235.2119	Function \$00 is switched OFF (\$00 OFF)	Flx	OUT	On Off	*	*	*	LED			BO						
235.2120	Function \$00 is ACTIVE (\$00 ACTIVE)	Flx	OUT	On Off	*	*	*	LED			BO						
235.2121	Function \$00 picked up (\$00 picked up)	Flx	OUT	On Off	On Off	*	*	LED			BO						
235.2122	Function \$00 Pickup Phase A (\$00 pickup A)	Flx	OUT	On Off	On Off	*	*	LED			BO						
235.2123	Function \$00 Pickup Phase B (\$00 pickup B)	Flx	OUT	On Off	On Off	*	*	LED			BO						
235.2124	Function \$00 Pickup Phase C (\$00 pickup C)	Flx	OUT	On Off	On Off	*	*	LED			BO						
235.2125	Function \$00 TRIP Delay Time Out (\$00 Time Out)	Flx	OUT	On Off	On Off	*	*	LED			BO						
235.2126	Function \$00 TRIP (\$00 TRIP)	Flx	OUT	On Off	on	*	*	LED			BO						
235.2128	Function \$00 has invalid settings (\$00 inval.set)	Flx	OUT	On Off	On Off	*	*	LED			BO						
236.2127	BLOCK Flexible Function (BLK. Flex.Fct.)	Device, General	IntSP	On Off	*	*	*	LED			BO						
253	Failure VT circuit: broken wire (VT brk. wire)	Measurem.Superv	OUT	On Off	*		*	LED			BO						
255	Failure VT circuit (Fail VT circuit)	Measurem.Superv	OUT	On Off	*		*	LED			BO						
256	Failure VT circuit: 1 pole broken wire (VT b.w. 1 pole)	Measurem.Superv	OUT	On Off	*		*	LED			BO						
257	Failure VT circuit: 2 pole broken wire (VT b.w. 2 pole)	Measurem.Superv	OUT	On Off	*		*	LED			BO						
258	Failure VT circuit: 3 pole broken wire (VT b.w. 3 pole)	Measurem.Superv	OUT	On Off	*		*	LED			BO						
272	Set Point Operating Hours (SP. Op Hours>)	SetPoint(Stat)	OUT	On Off	*		*	LED			BO		135	229	1	Yes	
301	Power System fault (Pow.Sys.Flt.)	Device, General	OUT	On Off	On Off								135	231	2	Yes	
302	Fault Event (Fault Event)	Device, General	OUT	*	on								135	232	2	Yes	

No.	Description	Function	Type of Information	Log Buffers				Configurable in Matrix					IEC 60870-5-103				
				Event Log ON/OFF	Trip (Fault) Log ON/OFF	Ground Fault Log ON/OFF	Marked in Oscill. Record	LED	Binary Input	Function Key	Relay	Chatter Suppression	Type	Information Number	Data Unit	General Interrogation	
303	sensitive Ground fault (sens Gnd ft)	Device, General	OUT			On Off											
320	Warn: Limit of Memory Data exceeded (Warn Mem. Data)	Device, General	OUT	On Off	*		*	LED			BO						
321	Warn: Limit of Memory Parameter exceeded (Warn Mem. Para.)	Device, General	OUT	On Off	*		*	LED			BO						
322	Warn: Limit of Memory Operation exceeded (Warn Mem. Oper.)	Device, General	OUT	On Off	*		*	LED			BO						
323	Warn: Limit of Memory New exceeded (Warn Mem. New)	Device, General	OUT	On Off	*		*	LED			BO						
335	>GOOSE-Stop (>GOOSE-Stop)	Device, General	SP	On Off			*	LED	BI	FC TN	BO						
356	>Manual close signal (>Manual Close)	P.System Data 2	SP	*	*		*	LED	BI		BO	150	6	1	Yes		
395	>I MIN/MAX Buffer Reset (>I MinMax Reset)	Min/Max meter	SP	on	*		*	LED	BI		BO						
396	>I1 MIN/MAX Buffer Reset (>I1 MiMaReset)	Min/Max meter	SP	on	*		*	LED	BI		BO						
397	>V MIN/MAX Buffer Reset (>V MiMaReset)	Min/Max meter	SP	on	*		*	LED	BI		BO						
398	>Vphph MIN/MAX Buffer Reset (>VphphMiMaRes)	Min/Max meter	SP	on	*		*	LED	BI		BO						
399	>V1 MIN/MAX Buffer Reset (>V1 MiMa Reset)	Min/Max meter	SP	on	*		*	LED	BI		BO						
400	>P MIN/MAX Buffer Reset (>P MiMa Reset)	Min/Max meter	SP	on	*		*	LED	BI		BO						
401	>S MIN/MAX Buffer Reset (>S MiMa Reset)	Min/Max meter	SP	on	*		*	LED	BI		BO						
402	>Q MIN/MAX Buffer Reset (>Q MiMa Reset)	Min/Max meter	SP	on	*		*	LED	BI		BO						
403	>Idmd MIN/MAX Buffer Reset (>Idmd MiMaReset)	Min/Max meter	SP	on	*		*	LED	BI		BO						
404	>Pdmd MIN/MAX Buffer Reset (>Pdmd MiMaReset)	Min/Max meter	SP	on	*		*	LED	BI		BO						
405	>Qdmd MIN/MAX Buffer Reset (>Qdmd MiMaReset)	Min/Max meter	SP	on	*		*	LED	BI		BO						
406	>Sdmd MIN/MAX Buffer Reset (>Sdmd MiMaReset)	Min/Max meter	SP	on	*		*	LED	BI		BO						
407	>Frq. MIN/MAX Buffer Reset (>Frq MiMa Reset)	Min/Max meter	SP	on	*		*	LED	BI		BO						
408	>Power Factor MIN/MAX Buffer Reset (>PF MiMaReset)	Min/Max meter	SP	on	*		*	LED	BI		BO						
409	>BLOCK Op Counter (>BLOCK Op Count)	Statistics	SP	On Off			*	LED	BI		BO						
412	>Theta MIN/MAX Buffer Reset (>Θ MiMa Reset)	Min/Max meter	SP	on	*		*	LED	BI		BO						
465.4011	Local 81V Enable command (Loc 81V En)	81 O/U Freq.	IntSP	On Off	*		*	LED			BO						
466.4010	Trip via control command (Cmd Trip)	P.System Data 2	IntSP	On Off	*		*	LED			BO						
501	Relay PICKUP (Relay PICKUP)	P.System Data 2	OUT		ON		m	LED			BO	150	151	2	Yes		
502	Relay Drop Out (Relay Drop Out)	Device, General	SP	*	*												
510	General CLOSE of relay (Relay CLOSE)	Device, General	SP	*	*												
511	Relay GENERAL TRIP command (Relay TRIP)	P.System Data 2	OUT		ON		m	LED			BO	150	161	2	Yes		

Appendix
A.9 Information List

No.	Description	Function	Type of Information	Log Buffers				Configurable in Matrix					IEC 60870-5-103			
				Event Log ON/OFF	Trip (Fault) Log ON/OFF	Ground Fault Log ON/OFF	Marked in Oscill. Record	LED	Binary Input	Function Key	Relay	Chatter Suppression	Type	Information Number	Data Unit	General Interrogation
533	Primary fault current Ia (Ia =)	P.System Data 2	VI		On Off								150	177	4	No
534	Primary fault current Ib (Ib =)	P.System Data 2	VI		On Off								150	178	4	No
535	Primary fault current Ic (Ic =)	P.System Data 2	VI		On Off								150	179	4	No
545	Time from Pickup to drop out (PU Time)	Device, General	VI													
546	Time from Pickup to TRIP (TRIP Time)	Device, General	VI													
561	Manual close signal detected (Man.Clos.Detect)	P.System Data 2	OUT	On Off	*		*	LED			BO					
916	Increment of active energy (WpΔ=)	Energy	-													
917	Increment of reactive energy (WqΔ=)	Energy	-													
1020	Counter of operating hours (Op.Hours=)	Statistics	VI													
1021	Accumulation of interrupted current Ph A (Σ Ia =)	Statistics	VI													
1022	Accumulation of interrupted current Ph B (Σ Ib =)	Statistics	VI													
1023	Accumulation of interrupted current Ph C (Σ Ic =)	Statistics	VI													
1106	>Start Fault Locator (>Start Flt. Loc)	Fault Locator	SP	on	*		*	LED	BI		BO		151	6	1	Yes
1114	Flt Locator: primary RESISTANCE (Rpri =)	Fault Locator	VI		On Off								151	14	4	No
1115	Flt Locator: primary REACTANCE (Xpri =)	Fault Locator	VI		On Off								151	15	4	No
1117	Flt Locator: secondary RESISTANCE (Rsec =)	Fault Locator	VI		On Off								151	17	4	No
1118	Flt Locator: secondary REACTANCE (Xsec =)	Fault Locator	VI		On Off								151	18	4	No
1119	Flt Locator: Distance to fault (dist =)	Fault Locator	VI		On Off								151	19	4	No
1120	Flt Locator: Distance [%] to fault (d[%] =)	Fault Locator	VI		On Off								151	20	4	No
1122	Flt Locator: Distance to fault (dist =)	Fault Locator	VI		On Off								151	22	4	No
1123	Fault Locator Loop AG (FL Loop AG)	Fault Locator	OUT	*	on		*	LED			BO					
1124	Fault Locator Loop BG (FL Loop BG)	Fault Locator	OUT	*	on		*	LED			BO					
1125	Fault Locator Loop CG (FL Loop CG)	Fault Locator	OUT	*	on		*	LED			BO					
1126	Fault Locator Loop AB (FL Loop AB)	Fault Locator	OUT	*	on		*	LED			BO					
1127	Fault Locator Loop BC (FL Loop BC)	Fault Locator	OUT	*	on		*	LED			BO					
1128	Fault Locator Loop CA (FL Loop CA)	Fault Locator	OUT	*	on		*	LED			BO					
1132	Fault location invalid (Flt.Loc.invalid)	Fault Locator	OUT	*	on		*	LED			BO					
1201	>BLOCK 64 (>BLOCK 64)	Sens. Gnd Fault	SP	On Off	*		*	LED	BI		BO		151	101	1	Yes

No.	Description	Function	Type of Information	Log Buffers				Configurable in Matrix					IEC 60870-5-103			
				Event Log ON/OFF	Trip (Fault) Log ON/OFF	Ground Fault Log ON/OFF	Marked in Oscill. Record	LED	Binary Input	Function Key	Relay	Chatter Suppression	Type	Information Number	Data Unit	General Interrogation
1202	>BLOCK 50Ns-2 (>BLOCK 50Ns-2)	Sens. Gnd Fault	SP	On Off	*		*	LED	BI		BO		151	102	1	Yes
1203	>BLOCK 50Ns-1 (>BLOCK 50Ns-1)	Sens. Gnd Fault	SP	On Off	*		*	LED	BI		BO		151	103	1	Yes
1204	>BLOCK 51Ns (>BLOCK 51Ns)	Sens. Gnd Fault	SP	On Off	*		*	LED	BI		BO		151	104	1	Yes
1207	>BLOCK 50Ns/67Ns (>BLK 50Ns/67Ns)	Sens. Gnd Fault	SP	On Off	*		*	LED	BI		BO		151	107	1	Yes
1211	50Ns/67Ns is OFF (50Ns/67Ns OFF)	Sens. Gnd Fault	OUT	On Off	*		*	LED			BO		151	111	1	Yes
1212	50Ns/67Ns is ACTIVE (50Ns/67Ns ACT)	Sens. Gnd Fault	OUT	On Off	*		*	LED			BO		151	112	1	Yes
1215	64 displacement voltage pick up (64 Pickup)	Sens. Gnd Fault	OUT	*	On Off		*	LED			BO		151	115	2	Yes
1217	64 displacement voltage element TRIP (64 TRIP)	Sens. Gnd Fault	OUT	*	on		m	LED			BO		151	117	2	Yes
1221	50Ns-2 Pickup (50Ns-2 Pickup)	Sens. Gnd Fault	OUT	*	On Off		*	LED			BO		151	121	2	Yes
1223	50Ns-2 TRIP (50Ns-2 TRIP)	Sens. Gnd Fault	OUT	*	on		m	LED			BO		151	123	2	Yes
1224	50Ns-1 Pickup (50Ns-1 Pickup)	Sens. Gnd Fault	OUT	*	On Off		*	LED			BO		151	124	2	Yes
1226	50Ns-1 TRIP (50Ns-1 TRIP)	Sens. Gnd Fault	OUT	*	on		m	LED			BO		151	126	2	Yes
1227	51Ns picked up (51Ns Pickup)	Sens. Gnd Fault	OUT	*	On Off		*	LED			BO		151	127	2	Yes
1229	51Ns TRIP (51Ns TRIP)	Sens. Gnd Fault	OUT	*	on		m	LED			BO		151	129	2	Yes
1230	Sensitive ground fault detection BLOCKED (Sens. Gnd block)	Sens. Gnd Fault	OUT	On Off	On Off		*	LED			BO		151	130	1	Yes
1264	Corr. Resistive Earth current (IEEa =)	Sens. Gnd Fault	VI				On Off									
1265	Corr. Reactive Earth current (IEEr =)	Sens. Gnd Fault	VI				On Off									
1266	Earth current, absolute Value (IEE =)	Sens. Gnd Fault	VI				On Off									
1267	Displacement Voltage VGND, 3Vo (VGND, 3Vo)	Sens. Gnd Fault	VI				On Off									
1271	Sensitive Ground fault pick up (Sens.Gnd Pickup)	Sens. Gnd Fault	OUT	*	*			LED			BO		151	171	1	Yes
1272	Sensitive Ground fault picked up in Ph A (Sens. Gnd Ph A)	Sens. Gnd Fault	OUT	On Off	on	On Off	*	LED			BO		160	48	1	Yes
1273	Sensitive Ground fault picked up in Ph B (Sens. Gnd Ph B)	Sens. Gnd Fault	OUT	On Off	on	On Off	*	LED			BO		160	49	1	Yes
1274	Sensitive Ground fault picked up in Ph C (Sens. Gnd Ph C)	Sens. Gnd Fault	OUT	On Off	on	On Off	*	LED			BO		160	50	1	Yes
1276	Sensitive Gnd fault in forward direction (SensGnd Forward)	Sens. Gnd Fault	OUT	On Off	on	On Off	*	LED			BO		160	51	1	Yes
1277	Sensitive Gnd fault in reverse direction (SensGnd Reverse)	Sens. Gnd Fault	OUT	On Off	on	On Off	*	LED			BO		160	52	1	Yes
1278	Sensitive Gnd fault direction undefined (SensGnd undef.)	Sens. Gnd Fault	OUT	On Off	on	On Off	*	LED			BO		151	178	1	Yes
1403	>BLOCK 50BF (>BLOCK 50BF)	50BF BkrFailure	SP	On Off	*		*	LED	BI		BO		166	103	1	Yes
1404	>50BF Activate 3I0> threshold (>50BFactiv.3I0>)	50BF BkrFailure	SP	On Off	*		*	LED	BI		BO					
1431	>50BF initiated externally (>50BF ext SRC)	50BF BkrFailure	SP	On Off	*		*	LED	BI		BO		166	104	1	Yes

A.9 Information List

No.	Description	Function	Type of Information	Log Buffers				Configurable in Matrix					IEC 60870-5-103			
				Event Log ON/OFF	Trip (Fault) Log ON/OFF	Ground Fault Log ON/OFF	Marked in Oscill. Record	LED	Binary Input	Function Key	Relay	Chatter Suppression	Type	Information Number	Data Unit	General Interrogation
1451	50BF is switched OFF (50BF OFF)	50BF BkrFailure	OUT	On Off	*		*	LED			BO		166	151	1	Yes
1452	50BF is BLOCKED (50BF BLOCK)	50BF BkrFailure	OUT	On Off	On Off		*	LED			BO		166	152	1	Yes
1453	50BF is ACTIVE (50BF ACTIVE)	50BF BkrFailure	OUT	On Off	*		*	LED			BO		166	153	1	Yes
1456	50BF (internal) PICKUP (50BF int Pickup)	50BF BkrFailure	OUT	*	On Off		*	LED			BO		166	156	2	Yes
1457	50BF (external) PICKUP (50BF ext Pickup)	50BF BkrFailure	OUT	*	On Off		*	LED			BO		166	157	2	Yes
1471	50BF TRIP (50BF TRIP)	50BF BkrFailure	OUT	*	on		m	LED			BO		160	85	2	No
1480	50BF (internal) TRIP (50BF int TRIP)	50BF BkrFailure	OUT	*	on		*	LED			BO		166	180	2	Yes
1481	50BF (external) TRIP (50BF ext TRIP)	50BF BkrFailure	OUT	*	on		*	LED			BO		166	181	2	Yes
1503	>BLOCK 49 Overload Protection (>BLOCK 49 O/L)	49 Th.Overload	SP	*	*		*	LED	BI		BO		167	3	1	Yes
1507	>Emergency start of motors (>EmergencyStart)	49 Th.Overload	SP	On Off	*		*	LED	BI		BO		167	7	1	Yes
1511	49 Overload Protection is OFF (49 O / L OFF)	49 Th.Overload	OUT	On Off	*		*	LED			BO		167	11	1	Yes
1512	49 Overload Protection is BLOCKED (49 O/L BLOCK)	49 Th.Overload	OUT	On Off	On Off		*	LED			BO		167	12	1	Yes
1513	49 Overload Protection is ACTIVE (49 O/L ACTIVE)	49 Th.Overload	OUT	On Off	*		*	LED			BO		167	13	1	Yes
1515	49 Overload Current Alarm (I alarm) (49 O/L I Alarm)	49 Th.Overload	OUT	On Off	*		*	LED			BO		167	15	1	Yes
1516	49 Overload Alarm! Near Thermal Trip (49 O/L θ Alarm)	49 Th.Overload	OUT	On Off	*		*	LED			BO		167	16	1	Yes
1517	49 Winding Overload (49 Winding O/L)	49 Th.Overload	OUT	On Off	*		*	LED			BO		167	17	1	Yes
1521	49 Thermal Overload TRIP (49 Th O/L TRIP)	49 Th.Overload	OUT	*	on		m	LED			BO		167	21	2	Yes
1580	>49 Reset of Thermal Overload Image (>RES 49 Image)	49 Th.Overload	SP	On Off	*		*	LED	BI		BO					
1581	49 Thermal Overload Image reset (49 Image res.)	49 Th.Overload	OUT	On Off	*		*	LED			BO					
1704	>BLOCK 50/51 (>BLK 50/51)	50/51 Overcur.	SP	*	*		*	LED	BI		BO					
1714	>BLOCK 50N/51N (>BLK 50N/51N)	50/51 Overcur.	SP	*	*		*	LED	BI		BO					
1718	>BLOCK 50-3 (>BLOCK 50-3)	50/51 Overcur.	SP	*	*		*	LED	BI		BO		60	144	1	Yes
1719	>BLOCK 50N-3 (>BLOCK 50N-3)	50/51 Overcur.	SP	*	*		*	LED	BI		BO		60	145	1	Yes
1721	>BLOCK 50-2 (>BLOCK 50-2)	50/51 Overcur.	SP	*	*		*	LED	BI		BO		60	1	1	Yes
1722	>BLOCK 50-1 (>BLOCK 50-1)	50/51 Overcur.	SP	*	*		*	LED	BI		BO		60	2	1	Yes
1723	>BLOCK 51 (>BLOCK 51)	50/51 Overcur.	SP	*	*		*	LED	BI		BO		60	3	1	Yes
1724	>BLOCK 50N-2 (>BLOCK 50N-2)	50/51 Overcur.	SP	*	*		*	LED	BI		BO		60	4	1	Yes
1725	>BLOCK 50N-1 (>BLOCK 50N-1)	50/51 Overcur.	SP	*	*		*	LED	BI		BO		60	5	1	Yes
1726	>BLOCK 51N (>BLOCK 51N)	50/51 Overcur.	SP	*	*		*	LED	BI		BO		60	6	1	Yes
1730	>BLOCK Cold-Load-Pickup (>BLOCK CLP)	ColdLoadPickup	SP	*	*		*	LED	BI		BO					
1731	>BLOCK Cold-Load-Pickup stop timer (>BLK CLP stpTim)	ColdLoadPickup	SP	On Off	*		*	LED	BI		BO		60	243	1	Yes
1732	>ACTIVATE Cold-Load-Pickup (>ACTIVATE CLP)	ColdLoadPickup	SP	On Off	*		*	LED	BI		BO					

No.	Description	Function	Type of Information	Log Buffers				Configurable in Matrix					IEC 60870-5-103			
				Event Log ON/OFF	Trip (Fault) Log ON/OFF	Ground Fault Log ON/OFF	Marked in Oscill. Record	LED	Binary Input	Function Key	Relay	Chatter Suppression	Type	Information Number	Data Unit	General Interrogation
1751	50/51 O/C switched OFF (50/51 PH OFF)	50/51 Overcur.	OUT	On Off	*		*	LED			BO		60	21	1	Yes
1752	50/51 O/C is BLOCKED (50/51 PH BLK)	50/51 Overcur.	OUT	On Off	On Off		*	LED			BO		60	22	1	Yes
1753	50/51 O/C is ACTIVE (50/51 PH ACT)	50/51 Overcur.	OUT	On Off	*		*	LED			BO		60	23	1	Yes
1756	50N/51N is OFF (50N/51N OFF)	50/51 Overcur.	OUT	On Off	*		*	LED			BO		60	26	1	Yes
1757	50N/51N is BLOCKED (50N/51N BLK)	50/51 Overcur.	OUT	On Off	On Off		*	LED			BO		60	27	1	Yes
1758	50N/51N is ACTIVE (50N/51N ACT)	50/51 Overcur.	OUT	On Off	*		*	LED			BO		60	28	1	Yes
1761	50(N)/51(N) O/C PICKUP (50(N)/51(N) PU)	50/51 Overcur.	OUT	*	On Off		m	LED			BO		160	84	2	Yes
1762	50/51 Phase A picked up (50/51 Ph A PU)	50/51 Overcur.	OUT	*	On Off		m	LED			BO		160	64	2	Yes
1763	50/51 Phase B picked up (50/51 Ph B PU)	50/51 Overcur.	OUT	*	On Off		m	LED			BO		160	65	2	Yes
1764	50/51 Phase C picked up (50/51 Ph C PU)	50/51 Overcur.	OUT	*	On Off		m	LED			BO		160	66	2	Yes
1765	50N/51N picked up (50N/51NPickedup)	50/51 Overcur.	OUT	*	On Off		m	LED			BO		160	67	2	Yes
1767	50-3 picked up (50-3 picked up)	50/51 Overcur.	OUT	*	On Off		*	LED			BO		60	146	2	Yes
1768	50N-3 picked up (50N-3 picked up)	50/51 Overcur.	OUT	*	On Off		*	LED			BO		60	147	2	Yes
1769	50-3 TRIP (50-3 TRIP)	50/51 Overcur.	OUT	*	on		*	LED			BO		60	148	2	Yes
1770	50N-3 TRIP (50N-3 TRIP)	50/51 Overcur.	OUT	*	on		*	LED			BO		60	149	2	Yes
1787	50-3 TimeOut (50-3 TimeOut)	50/51 Overcur.	OUT	*	*		*	LED			BO		60	167	2	Yes
1788	50N-3 TimeOut (50N-3 TimeOut)	50/51 Overcur.	OUT	*	*		*	LED			BO		60	168	2	Yes
1791	50(N)/51(N) TRIP (50(N)/51(N)TRIP)	50/51 Overcur.	OUT	*	on		m	LED			BO		160	68	2	No
1800	50-2 picked up (50-2 picked up)	50/51 Overcur.	OUT	*	On Off		*	LED			BO		60	75	2	Yes
1804	50-2 Time Out (50-2 TimeOut)	50/51 Overcur.	OUT	*	*		*	LED			BO		60	49	2	Yes
1805	50-2 TRIP (50-2 TRIP)	50/51 Overcur.	OUT	*	on		m	LED			BO		160	91	2	No
1810	50-1 picked up (50-1 picked up)	50/51 Overcur.	OUT	*	On Off		*	LED			BO		60	76	2	Yes
1814	50-1 Time Out (50-1 TimeOut)	50/51 Overcur.	OUT	*	*		*	LED			BO		60	53	2	Yes
1815	50-1 TRIP (50-1 TRIP)	50/51 Overcur.	OUT	*	on		m	LED			BO		160	90	2	No
1820	51 picked up (51 picked up)	50/51 Overcur.	OUT	*	On Off		*	LED			BO		60	77	2	Yes
1824	51 Time Out (51 Time Out)	50/51 Overcur.	OUT	*	*		*	LED			BO		60	57	2	Yes
1825	51 TRIP (51 TRIP)	50/51 Overcur.	OUT	*	on		m	LED			BO		60	58	2	Yes
1831	50N-2 picked up (50N-2 picked up)	50/51 Overcur.	OUT	*	On Off		*	LED			BO		60	59	2	Yes
1832	50N-2 Time Out (50N-2 TimeOut)	50/51 Overcur.	OUT	*	*		*	LED			BO		60	60	2	Yes
1833	50N-2 TRIP (50N-2 TRIP)	50/51 Overcur.	OUT	*	on		m	LED			BO		160	93	2	No
1834	50N-1 picked up (50N-1 picked up)	50/51 Overcur.	OUT	*	On Off		*	LED			BO		60	62	2	Yes
1835	50N-1 Time Out (50N-1 TimeOut)	50/51 Overcur.	OUT	*	*		*	LED			BO		60	63	2	Yes
1836	50N-1 TRIP (50N-1 TRIP)	50/51 Overcur.	OUT	*	on		m	LED			BO		160	92	2	No

Appendix
A.9 Information List

No.	Description	Function	Type of Information	Log Buffers				Configurable in Matrix					IEC 60870-5-103			
				Event Log ON/OFF	Trip (Fault) Log ON/OFF	Ground Fault Log ON/OFF	Marked in Oscill. Record	LED	Binary Input	Function Key	Relay	Chatter Suppression	Type	Information Number	Data Unit	General Interrogation
1837	51N picked up (51N picked up)	50/51 Overcur.	OUT	*	On Off		*	LED			BO		60	64	2	Yes
1838	51N Time Out (51N TimeOut)	50/51 Overcur.	OUT	*	*		*	LED			BO		60	65	2	Yes
1839	51N TRIP (51N TRIP)	50/51 Overcur.	OUT	*	on		m	LED			BO		60	66	2	Yes
1840	Phase A inrush detection (PhA InrushDet)	50/51 Overcur.	OUT	*	On Off		*	LED			BO		60	101	2	Yes
1841	Phase B inrush detection (PhB InrushDet)	50/51 Overcur.	OUT	*	On Off		*	LED			BO		60	102	2	Yes
1842	Phase C inrush detection (PhC InrushDet)	50/51 Overcur.	OUT	*	On Off		*	LED			BO		60	103	2	Yes
1843	Cross blk: PhX blocked PhY (INRUSH X-BLK)	50/51 Overcur.	OUT	*	On Off		*	LED			BO		60	104	2	Yes
1851	50-1 BLOCKED (50-1 BLOCKED)	50/51 Overcur.	OUT	On Off	On Off		*	LED			BO		60	105	1	Yes
1852	50-2 BLOCKED (50-2 BLOCKED)	50/51 Overcur.	OUT	On Off	On Off		*	LED			BO		60	106	1	Yes
1853	50N-1 BLOCKED (50N-1 BLOCKED)	50/51 Overcur.	OUT	On Off	On Off		*	LED			BO		60	107	1	Yes
1854	50N-2 BLOCKED (50N-2 BLOCKED)	50/51 Overcur.	OUT	On Off	On Off		*	LED			BO		60	108	1	Yes
1855	51 BLOCKED (51 BLOCKED)	50/51 Overcur.	OUT	On Off	On Off		*	LED			BO		60	109	1	Yes
1856	51N BLOCKED (51N BLOCKED)	50/51 Overcur.	OUT	On Off	On Off		*	LED			BO		60	110	1	Yes
1866	51 Disk emulation Pickup (51 Disk Pickup)	50/51 Overcur.	OUT	*	*		*	LED			BO					
1867	51N Disk emulation picked up (51N Disk Pickup)	50/51 Overcur.	OUT	*	*		*	LED			BO					
1994	Cold-Load-Pickup switched OFF (CLP OFF)	ColdLoadPickup	OUT	On Off	*		*	LED			BO		60	244	1	Yes
1995	Cold-Load-Pickup is BLOCKED (CLP BLOCKED)	ColdLoadPickup	OUT	On Off	On Off		*	LED			BO		60	245	1	Yes
1996	Cold-Load-Pickup is RUNNING (CLP running)	ColdLoadPickup	OUT	On Off	*		*	LED			BO		60	246	1	Yes
1997	Dynamic settings are ACTIVE (Dyn set. ACTIVE)	ColdLoadPickup	OUT	On Off	*		*	LED			BO		60	247	1	Yes
2603	67N-3 TRIP (67N-3 TRIP)	67 Direct. O/C	OUT	*	on		*	LED			BO					
2604	>BLOCK 67/67-TOC (>BLK 67/67-TOC)	67 Direct. O/C	SP	*	*		*	LED	BI		BO					
2605	67N-3 is BLOCKED (67N-3 BLOCKED)	67 Direct. O/C	OUT	On Off	On Off		*	LED			BO					
2606	67-3 is BLOCKED (67-3 BLOCKED)	67 Direct. O/C	OUT	On Off	On Off		*	LED			BO					
2614	>BLOCK 67N/67N-TOC (>BLK 67N/67NTOC)	67 Direct. O/C	SP	*	*		*	LED	BI		BO					
2615	>BLOCK 67-2 (>BLOCK 67-2)	67 Direct. O/C	SP	*	*		*	LED	BI		BO		63	73	1	Yes
2616	>BLOCK 67N-2 (>BLOCK 67N-2)	67 Direct. O/C	SP	*	*		*	LED	BI		BO		63	74	1	Yes
2617	>BLOCK 67-3 (>BLOCK 67-3)	67 Direct. O/C	SP	*	*		*	LED	BI		BO					
2618	>BLOCK 67N-3 (>BLOCK 67N-3)	67 Direct. O/C	SP	*	*		*	LED	BI		BO					
2621	>BLOCK 67-1 (>BLOCK 67-1)	67 Direct. O/C	SP	*	*		*	LED	BI		BO		63	1	1	Yes
2622	>BLOCK 67-TOC (>BLOCK 67-TOC)	67 Direct. O/C	SP	*	*		*	LED	BI		BO		63	2	1	Yes
2623	>BLOCK 67N-1 (>BLOCK 67N-1)	67 Direct. O/C	SP	*	*		*	LED	BI		BO		63	3	1	Yes

No.	Description	Function	Type of Information	Log Buffers				Configurable in Matrix					IEC 60870-5-103			
				Event Log ON/OFF	Trip (Fault) Log ON/OFF	Ground Fault Log ON/OFF	Marked in Oscill. Record	LED	Binary Input	Function Key	Relay	Chatter Suppression	Type	Information Number	Data Unit	General Interrogation
2624	>BLOCK 67N-TOC (>BLOCK 67N-TOC)	67 Direct. O/C	SP	*	*		*	LED	BI		BO		63	4	1	Yes
2628	Phase A forward (Phase A forward)	67 Direct. O/C	OUT	on	*		*	LED			BO		63	81	1	Yes
2629	Phase B forward (Phase B forward)	67 Direct. O/C	OUT	on	*		*	LED			BO		63	82	1	Yes
2630	Phase C forward (Phase C forward)	67 Direct. O/C	OUT	on	*		*	LED			BO		63	83	1	Yes
2632	Phase A reverse (Phase A reverse)	67 Direct. O/C	OUT	on	*		*	LED			BO		63	84	1	Yes
2633	Phase B reverse (Phase B reverse)	67 Direct. O/C	OUT	on	*		*	LED			BO		63	85	1	Yes
2634	Phase C reverse (Phase C reverse)	67 Direct. O/C	OUT	on	*		*	LED			BO		63	86	1	Yes
2635	Ground forward (Ground forward)	67 Direct. O/C	OUT	on	*		*	LED			BO		63	87	1	Yes
2636	Ground reverse (Ground reverse)	67 Direct. O/C	OUT	on	*		*	LED			BO		63	88	1	Yes
2637	67-1 is BLOCKED (67-1 BLOCKED)	67 Direct. O/C	OUT	On Off	On Off		*	LED			BO		63	91	1	Yes
2642	67-2 picked up (67-2 picked up)	67 Direct. O/C	OUT	*	On Off		*	LED			BO		63	67	2	Yes
2646	67N-2 picked up (67N-2 picked up)	67 Direct. O/C	OUT	*	On Off		*	LED			BO		63	62	2	Yes
2647	67-2 Time Out (67-2 Time Out)	67 Direct. O/C	OUT	*	*		*	LED			BO		63	71	2	Yes
2648	67N-2 Time Out (67N-2 Time Out)	67 Direct. O/C	OUT	*	*		*	LED			BO		63	63	2	Yes
2649	67-2 TRIP (67-2 TRIP)	67 Direct. O/C	OUT	*	on		m	LED			BO		63	72	2	Yes
2651	67/67-TOC switched OFF (67/67-TOC OFF)	67 Direct. O/C	OUT	On Off	*		*	LED			BO		63	10	1	Yes
2652	67/67-TOC is BLOCKED (67 BLOCKED)	67 Direct. O/C	OUT	On Off	On Off		*	LED			BO		63	11	1	Yes
2653	67/67-TOC is ACTIVE (67 ACTIVE)	67 Direct. O/C	OUT	On Off	*		*	LED			BO		63	12	1	Yes
2655	67-2 is BLOCKED (67-2 BLOCKED)	67 Direct. O/C	OUT	On Off	On Off		*	LED			BO		63	92	1	Yes
2656	67N/67N-TOC switched OFF (67N OFF)	67 Direct. O/C	OUT	On Off	*		*	LED			BO		63	13	1	Yes
2657	67N/67N-TOC is BLOCKED (67N BLOCKED)	67 Direct. O/C	OUT	On Off	On Off		*	LED			BO		63	14	1	Yes
2658	67N/67N-TOC is ACTIVE (67N ACTIVE)	67 Direct. O/C	OUT	On Off	*		*	LED			BO		63	15	1	Yes
2659	67N-1 is BLOCKED (67N-1 BLOCKED)	67 Direct. O/C	OUT	On Off	On Off		*	LED			BO		63	93	1	Yes
2660	67-1 picked up (67-1 picked up)	67 Direct. O/C	OUT	*	On Off		*	LED			BO		63	20	2	Yes
2664	67-1 Time Out (67-1 Time Out)	67 Direct. O/C	OUT	*	*		*	LED			BO		63	24	2	Yes
2665	67-1 TRIP (67-1 TRIP)	67 Direct. O/C	OUT	*	on		m	LED			BO		63	25	2	Yes
2668	67N-2 is BLOCKED (67N-2 BLOCKED)	67 Direct. O/C	OUT	On Off	On Off		*	LED			BO		63	94	1	Yes
2669	67-TOC is BLOCKED (67-TOC BLOCKED)	67 Direct. O/C	OUT	On Off	On Off		*	LED			BO		63	95	1	Yes
2670	67-TOC picked up (67-TOC picked up)	67 Direct. O/C	OUT	*	On Off		*	LED			BO		63	30	2	Yes
2674	67-TOC Time Out (67-TOC Time Out)	67 Direct. O/C	OUT	*	*		*	LED			BO		63	34	2	Yes
2675	67-TOC TRIP (67-TOC TRIP)	67 Direct. O/C	OUT	*	on		m	LED			BO		63	35	2	Yes

Appendix
A.9 Information List

No.	Description	Function	Type of Information	Log Buffers				Configurable in Matrix					IEC 60870-5-103				
				Event Log ON/OFF	Trip (Fault) Log ON/OFF	Ground Fault Log ON/OFF	Marked in Oscill. Record	LED	Binary Input	Function Key	Relay	Chatter Suppression	Type	Information Number	Data Unit	General Interrogation	
2676	67-TOC disk emulation is ACTIVE (67-TOC DiskPU)	67 Direct. O/C	OUT	*	*		*	LED			BO						
2677	67N-TOC is BLOCKED (67N-TOC BLOCKED)	67 Direct. O/C	OUT	On Off	On Off		*	LED			BO	63	96	1	Yes		
2678	67-3 TRIP (67-3 TRIP)	67 Direct. O/C	OUT	*	on		*	LED			BO						
2679	67N-2 TRIP (67N-2 TRIP)	67 Direct. O/C	OUT	*	on		m	LED			BO	63	64	2	Yes		
2681	67N-1 picked up (67N-1 picked up)	67 Direct. O/C	OUT	*	On Off		*	LED			BO	63	41	2	Yes		
2682	67N-1 Time Out (67N-1 Time Out)	67 Direct. O/C	OUT	*	*		*	LED			BO	63	42	2	Yes		
2683	67N-1 TRIP (67N-1 TRIP)	67 Direct. O/C	OUT	*	on		m	LED			BO	63	43	2	Yes		
2684	67N-TOC picked up (67N-TOCPickedup)	67 Direct. O/C	OUT	*	On Off		*	LED			BO	63	44	2	Yes		
2685	67N-TOC Time Out (67N-TOC TimeOut)	67 Direct. O/C	OUT	*	*		*	LED			BO	63	45	2	Yes		
2686	67N-TOC TRIP (67N-TOC TRIP)	67 Direct. O/C	OUT	*	on		m	LED			BO	63	46	2	Yes		
2687	67N-TOC disk emulation is ACTIVE (67N-TOC Disk PU)	67 Direct. O/C	OUT	*	*		*	LED			BO						
2691	67/67N picked up (67/67N pickedup)	67 Direct. O/C	OUT	*	On Off		m	LED			BO	63	50	2	Yes		
2692	67/67-TOC Phase A picked up (67 A picked up)	67 Direct. O/C	OUT	*	On Off		*	LED			BO	63	51	2	Yes		
2693	67/67-TOC Phase B picked up (67 B picked up)	67 Direct. O/C	OUT	*	On Off		*	LED			BO	63	52	2	Yes		
2694	67/67-TOC Phase C picked up (67 C picked up)	67 Direct. O/C	OUT	*	On Off		*	LED			BO	63	53	2	Yes		
2695	67N/67N-TOC picked up (67N picked up)	67 Direct. O/C	OUT	*	On Off		*	LED			BO	63	54	2	Yes		
2696	67/67N TRIP (67/67N TRIP)	67 Direct. O/C	OUT	*	on		m	LED			BO	63	55	2	Yes		
2697	67-3 picked up (67-3 picked up)	67 Direct. O/C	OUT	*	On Off		*	LED			BO						
2698	67N-3 picked up (67N-3 picked up)	67 Direct. O/C	OUT	*	On Off		*	LED			BO						
2699	67-3 Time Out (67-3 Time Out)	67 Direct. O/C	OUT	*	*		*	LED			BO						
2700	67N-3 Time Out (67N-3 Time Out)	67 Direct. O/C	OUT	*	*		*	LED			BO						
2701	>79 ON (>79 ON)	79M Auto Recl.	SP	On Off	*		*	LED	BI		BO	40	1	1	Yes		
2702	>79 OFF (>79 OFF)	79M Auto Recl.	SP	On Off	*		*	LED	BI		BO	40	2	1	Yes		
2703	>BLOCK 79 (>BLOCK 79)	79M Auto Recl.	SP	On Off	*		*	LED	BI		BO	40	3	1	Yes		
2711	>79 External start of internal A/R (>79 Start)	79M Auto Recl.	SP	*	On Off		*	LED	BI		BO						
2715	>Start 79 Ground program (>Start 79 Gnd)	79M Auto Recl.	SP	*	on		*	LED	BI		BO	40	15	2	Yes		
2716	>Start 79 Phase program (>Start 79 Ph)	79M Auto Recl.	SP	*	on		*	LED	BI		BO	40	16	2	Yes		
2720	>Enable 50/67-(N)-2 (override 79 blk) (>Enable ANSI#-2)	P.System Data 2	SP	On Off	*		*	LED	BI		BO	40	20	1	Yes		
2722	>Switch zone sequence coordination ON (>ZSC ON)	79M Auto Recl.	SP	On Off	*		*	LED	BI		BO						
2723	>Switch zone sequence coordination OFF (>ZSC OFF)	79M Auto Recl.	SP	On Off	*		*	LED	BI		BO						

No.	Description	Function	Type of Information	Log Buffers				Configurable in Matrix					IEC 60870-5-103			
				Event Log ON/OFF	Trip (Fault) Log ON/OFF	Ground Fault Log ON/OFF	Marked in Oscill. Record	LED	Binary Input	Function Key	Relay	Chatter Suppression	Type	Information Number	Data Unit	General Interrogation
2730	>Circuit breaker READY for re-closing (>CB Ready)	79M Auto Recl.	SP	On Off	*		*	LED	BI		BO		40	30	1	Yes
2731	>79: Sync. release from ext. sync.-check (>Sync.release)	79M Auto Recl.	SP	*	on		*	LED	BI		BO					
2753	79: Max. Dead Time Start Delay expired (79 DT delay ex.)	79M Auto Recl.	OUT	on	*		*	LED			BO					
2754	>79: Dead Time Start Delay (>79 DT St.Delay)	79M Auto Recl.	SP	On Off	*		*	LED	BI		BO					
2781	79 Auto recloser is switched OFF (79 OFF)	79M Auto Recl.	OUT	on	*		*	LED			BO	40	81	1	Yes	
2782	79 Auto recloser is switched ON (79 ON)	79M Auto Recl.	IntSP	On Off	*		*	LED			BO	160	16	1	Yes	
2784	79 Auto recloser is NOT ready (79 is NOT ready)	79M Auto Recl.	OUT	On Off	*		*	LED			BO	160	130	1	Yes	
2785	79 - Auto-reclose is dynamically BLOCKED (79 DynBlock)	79M Auto Recl.	OUT	On Off	on		*	LED			BO	40	85	1	Yes	
2788	79: CB ready monitoring window expired (79 T-CBreadyExp)	79M Auto Recl.	OUT	on	*		*	LED			BO					
2801	79 - in progress (79 in progress)	79M Auto Recl.	OUT	*	on		*	LED			BO	40	101	2	Yes	
2808	79: CB open with no trip (79 BLK: CB open)	79M Auto Recl.	OUT	On Off	*		*	LED			BO					
2809	79: Start-signal monitoring time expired (79 T-Start Exp)	79M Auto Recl.	OUT	on	*		*	LED			BO					
2810	79: Maximum dead time expired (79 TdeadMax Exp)	79M Auto Recl.	OUT	on	*		*	LED			BO					
2823	79: no starter configured (79 no starter)	79M Auto Recl.	OUT	On Off	*		*	LED			BO					
2824	79: no cycle configured (79 no cycle)	79M Auto Recl.	OUT	On Off	*		*	LED			BO					
2827	79: blocking due to trip (79 BLK by trip)	79M Auto Recl.	OUT	on	*		*	LED			BO					
2828	79: blocking due to 3-phase pickup (79 BLK:3ph p.u.)	79M Auto Recl.	OUT	on	*		*	LED			BO					
2829	79: action time expired before trip (79 Tact expired)	79M Auto Recl.	OUT	on	*		*	LED			BO					
2830	79: max. no. of cycles exceeded (79 Max. No. Cyc)	79M Auto Recl.	OUT	on	*		*	LED			BO					
2844	79 1st cycle running (79 1stCyc. run.)	79M Auto Recl.	OUT	*	on		*	LED			BO					
2845	79 2nd cycle running (79 2ndCyc. run.)	79M Auto Recl.	OUT	*	on		*	LED			BO					
2846	79 3rd cycle running (79 3rdCyc. run.)	79M Auto Recl.	OUT	*	on		*	LED			BO					
2847	79 4th or higher cycle running (79 4thCyc. run.)	79M Auto Recl.	OUT	*	on		*	LED			BO					
2851	79 - Close command (79 Close)	79M Auto Recl.	OUT	*	on		m	LED			BO	160	128	2	No	
2862	79 - cycle successful (79 Successful)	79M Auto Recl.	OUT	on	on		*	LED			BO	40	162	1	Yes	
2863	79 - Lockout (79 Lockout)	79M Auto Recl.	OUT	on	on		*	LED			BO	40	163	2	Yes	
2865	79: Synchro-check request (79 Sync.Request)	79M Auto Recl.	OUT	*	on		*	LED			BO					
2878	79-A/R single phase reclosing sequence (79 L-N Sequence)	79M Auto Recl.	OUT	*	on		*	LED			BO	40	180	2	Yes	
2879	79-A/R multi-phase reclosing sequence (79 L-L Sequence)	79M Auto Recl.	OUT	*	on		*	LED			BO	40	181	2	Yes	

Appendix
A.9 Information List

No.	Description	Function	Type of Information	Log Buffers				Configurable in Matrix					IEC 60870-5-103				
				Event Log ON/OFF	Trip (Fault) Log ON/OFF	Ground Fault Log ON/OFF	Marked in Oscill. Record	LED	Binary Input	Function Key	Relay	Chatter Suppression	Type	Information Number	Data Unit	General Interrogation	
2883	Zone Sequencing is active (ZSC active)	79M Auto Recl.	OUT	On Off	on		*	LED			BO						
2884	Zone sequence coordination switched ON (ZSC ON)	79M Auto Recl.	OUT	on	*		*	LED			BO						
2885	Zone sequence coordination switched OFF (ZSC OFF)	79M Auto Recl.	OUT	on	*		*	LED			BO						
2889	79 1st cycle zone extension release (79 1.CycZoneRel)	79M Auto Recl.	OUT	*	*		*	LED			BO						
2890	79 2nd cycle zone extension release (79 2.CycZoneRel)	79M Auto Recl.	OUT	*	*		*	LED			BO						
2891	79 3rd cycle zone extension release (79 3.CycZoneRel)	79M Auto Recl.	OUT	*	*		*	LED			BO						
2892	79 4th cycle zone extension release (79 4.CycZoneRel)	79M Auto Recl.	OUT	*	*		*	LED			BO						
2896	No. of 1st AR-cycle CLOSE commands,3pole (79 #Close1./3p=)	Statistics	VI														
2898	No. of higher AR-cycle CLOSE commands,3p (79 #Close2./3p=)	Statistics	VI														
2899	79: Close request to Control Function (79 CloseRequest)	79M Auto Recl.	OUT	*	on		*	LED			BO						
4601	>52-a contact (OPEN, if bkr is open) (>52-a)	P.System Data 2	SP	On Off	*		*	LED	BI		BO						
4602	>52-b contact (OPEN, if bkr is closed) (>52-b)	P.System Data 2	SP	On Off	*		*	LED	BI		BO						
5143	>BLOCK 46 (>BLOCK 46)	46 Negative Seq	SP	*	*		*	LED	BI		BO	70	126	1	Yes		
5145	>Reverse Phase Rotation (>Reverse Rot.)	P.System Data 1	SP	On Off	*		*	LED	BI		BO						
5147	Phase rotation ABC (Rotation ABC)	P.System Data 1	OUT	On Off	*		*	LED			BO	70	128	1	Yes		
5148	Phase rotation ACB (Rotation ACB)	P.System Data 1	OUT	On Off	*		*	LED			BO	70	129	1	Yes		
5151	46 switched OFF (46 OFF)	46 Negative Seq	OUT	On Off	*		*	LED			BO	70	131	1	Yes		
5152	46 is BLOCKED (46 BLOCKED)	46 Negative Seq	OUT	On Off	On Off		*	LED			BO	70	132	1	Yes		
5153	46 is ACTIVE (46 ACTIVE)	46 Negative Seq	OUT	On Off	*		*	LED			BO	70	133	1	Yes		
5159	46-2 picked up (46-2 picked up)	46 Negative Seq	OUT	*	On Off		*	LED			BO	70	138	2	Yes		
5165	46-1 picked up (46-1 picked up)	46 Negative Seq	OUT	*	On Off		*	LED			BO	70	150	2	Yes		
5166	46-TOC picked up (46-TOC pickedup)	46 Negative Seq	OUT	*	On Off		*	LED			BO	70	141	2	Yes		
5170	46 TRIP (46 TRIP)	46 Negative Seq	OUT	*	on		m	LED			BO	70	149	2	Yes		
5171	46 Disk emulation picked up (46 Dsk pickedup)	46 Negative Seq	OUT	*	*		*	LED			BO						
5203	>BLOCK 81O/U (>BLOCK 81O/U)	81 O/U Freq.	SP	On Off	*		*	LED	BI		BO	70	176	1	Yes		
5206	>BLOCK 81-1 (>BLOCK 81-1)	81 O/U Freq.	SP	On Off	*		*	LED	BI		BO	70	177	1	Yes		
5207	>BLOCK 81-2 (>BLOCK 81-2)	81 O/U Freq.	SP	On Off	*		*	LED	BI		BO	70	178	1	Yes		
5208	>BLOCK 81-3 (>BLOCK 81-3)	81 O/U Freq.	SP	On Off	*		*	LED	BI		BO	70	179	1	Yes		
5209	>BLOCK 81-4 (>BLOCK 81-4)	81 O/U Freq.	SP	On Off	*		*	LED	BI		BO	70	180	1	Yes		

No.	Description	Function	Type of Information	Log Buffers				Configurable in Matrix					IEC 60870-5-103			
				Event Log ON/OFF	Trip (Fault) Log ON/OFF	Ground Fault Log ON/OFF	Marked in Oscill. Record	LED	Binary Input	Function Key	Relay	Chatter Suppression	Type	Information Number	Data Unit	General Interrogation
5211	81 OFF (81 OFF)	81 O/U Freq.	OUT	On Off	*		*	LED			BO		70	181	1	Yes
5212	81 BLOCKED (81 BLOCKED)	81 O/U Freq.	OUT	On Off	On Off		*	LED			BO		70	182	1	Yes
5213	81 ACTIVE (81 ACTIVE)	81 O/U Freq.	OUT	On Off	*		*	LED			BO		70	183	1	Yes
5214	81 Under Voltage Block (81 Under V Blk)	81 O/U Freq.	OUT	On Off	On Off		*	LED			BO		70	184	1	Yes
5232	81-1 picked up (81-1 picked up)	81 O/U Freq.	OUT	*	On Off		*	LED			BO		70	230	2	Yes
5233	81-2 picked up (81-2 picked up)	81 O/U Freq.	OUT	*	On Off		*	LED			BO		70	231	2	Yes
5234	81-3 picked up (81-3 picked up)	81 O/U Freq.	OUT	*	On Off		*	LED			BO		70	232	2	Yes
5235	81-4 picked up (81-4 picked up)	81 O/U Freq.	OUT	*	On Off		*	LED			BO		70	233	2	Yes
5236	81-1 TRIP (81-1 TRIP)	81 O/U Freq.	OUT	*	on		m	LED			BO		70	234	2	Yes
5237	81-2 TRIP (81-2 TRIP)	81 O/U Freq.	OUT	*	on		m	LED			BO		70	235	2	Yes
5238	81-3 TRIP (81-3 TRIP)	81 O/U Freq.	OUT	*	on		m	LED			BO		70	236	2	Yes
5239	81-4 TRIP (81-4 TRIP)	81 O/U Freq.	OUT	*	on		m	LED			BO		70	237	2	Yes
5951	>BLOCK 50 1Ph (>BLK 50 1Ph)	50 1Ph	SP	*	*		*	LED	BI		BO					
5952	>BLOCK 50 1Ph-1 (>BLK 50 1Ph-1)	50 1Ph	SP	*	*		*	LED	BI		BO					
5953	>BLOCK 50 1Ph-2 (>BLK 50 1Ph-2)	50 1Ph	SP	*	*		*	LED	BI		BO					
5961	50 1Ph is OFF (50 1Ph OFF)	50 1Ph	OUT	On Off	*		*	LED			BO					
5962	50 1Ph is BLOCKED (50 1Ph BLOCKED)	50 1Ph	OUT	On Off	On Off		*	LED			BO					
5963	50 1Ph is ACTIVE (50 1Ph ACTIVE)	50 1Ph	OUT	On Off	*		*	LED			BO					
5966	50 1Ph-1 is BLOCKED (50 1Ph-1 BLK)	50 1Ph	OUT	On Off	On Off		*	LED			BO					
5967	50 1Ph-2 is BLOCKED (50 1Ph-2 BLK)	50 1Ph	OUT	On Off	On Off		*	LED			BO					
5971	50 1Ph picked up (50 1Ph Pickup)	50 1Ph	OUT	*	On Off		*	LED			BO					
5972	50 1Ph TRIP (50 1Ph TRIP)	50 1Ph	OUT	*	on		*	LED			BO					
5974	50 1Ph-1 picked up (50 1Ph-1 PU)	50 1Ph	OUT	*	On Off		*	LED			BO					
5975	50 1Ph-1 TRIP (50 1Ph-1 TRIP)	50 1Ph	OUT	*	on		*	LED			BO					
5977	50 1Ph-2 picked up (50 1Ph-2 PU)	50 1Ph	OUT	*	On Off		*	LED			BO					
5979	50 1Ph-2 TRIP (50 1Ph-2 TRIP)	50 1Ph	OUT	*	on		*	LED			BO					
5980	50 1Ph: I at pick up (50 1Ph I:)	50 1Ph	VI	*	On Off											
6401	>QV-Protection Blocked (>27/Q Block)	27/Q	SP	*	*		*	LED	BI		BO		74	201	1	Yes
6411	27/Q -Protection off (27/Q OFF)	27/Q	OUT	On Off	*		*	LED			BO		74	211	1	Yes
6412	27/Q -Protection blocked (27/Q block)	27/Q	OUT	On Off	On Off		*	LED			BO		74	212	1	Yes
6413	27/Q -Protection active (27/Q ACT)	27/Q	OUT	On Off	*		*	LED			BO		74	213	1	Yes

A.9 Information List

No.	Description	Function	Type of Information	Log Buffers				Configurable in Matrix					IEC 60870-5-103			
				Event Log ON/OFF	Trip (Fault) Log ON/OFF	Ground Fault Log ON/OFF	Marked in Oscill. Record	LED	Binary Input	Function Key	Relay	Chatter Suppression	Type	Information Number	Data Unit	General Interrogation
6421	27/Q -Protection Gen TRIP (27/Q Gen TRIP)	27/Q	OUT	*	On Off		*	LED			BO	74	221	2	Yes	
6422	27/Q -Protection Grid TRIP (27/Q Grid TRIP)	27/Q	OUT	*	On Off		*	LED			BO	74	222	2	Yes	
6423	27/Q-Protection PICKUP (27/Q PICKUP)	27/Q	OUT	*	On Off		*	LED			BO	74	223	2	No	
6424	Reclosure release (Reclosure rel.)	27/Q	OUT	*	On Off		*	LED			BO	74	224	2	Yes	
6425	27/Q pickup blocked by Inrush (27/Q blk.b.Inr.)	27/Q	OUT	On Off	On Off		*	LED			BO	74	225	2	Yes	
6503	>BLOCK 27 undervoltage protection (>BLOCK 27)	27/59 O/U Volt.	SP	*	*		*	LED	BI		BO	74	3	1	Yes	
6505	>27-Switch current supervision ON (>27 I SUPRVSN)	27/59 O/U Volt.	SP	On Off	*		*	LED	BI		BO	74	5	1	Yes	
6506	>BLOCK 27-1 Undervoltage protection (>BLOCK 27-1)	27/59 O/U Volt.	SP	On Off	*		*	LED	BI		BO	74	6	1	Yes	
6508	>BLOCK 27-2 Undervoltage protection (>BLOCK 27-2)	27/59 O/U Volt.	SP	On Off	*		*	LED	BI		BO	74	8	1	Yes	
6509	>Failure: Feeder VT (>FAIL:FEEDER VT)	Measuram.Superv	SP	On Off	*		*	LED	BI		BO	74	9	1	Yes	
6510	>Failure: Busbar VT (>FAIL: BUS VT)	Measuram.Superv	SP	On Off	*		*	LED	BI		BO	74	10	1	Yes	
6513	>BLOCK 59 overvoltage protection (>BLOCK 59)	27/59 O/U Volt.	SP	*	*		*	LED	BI		BO	74	13	1	Yes	
6530	27 Undervoltage protection switched OFF (27 OFF)	27/59 O/U Volt.	OUT	On Off	*		*	LED			BO	74	30	1	Yes	
6531	27 Undervoltage protection is BLOCKED (27 BLOCKED)	27/59 O/U Volt.	OUT	On Off	On Off		*	LED			BO	74	31	1	Yes	
6532	27 Undervoltage protection is ACTIVE (27 ACTIVE)	27/59 O/U Volt.	OUT	On Off	*		*	LED			BO	74	32	1	Yes	
6533	27-1 Undervoltage picked up (27-1 picked up)	27/59 O/U Volt.	OUT	*	On Off		*	LED			BO	74	33	2	Yes	
6534	27-1 Undervoltage PICKUP w/curr. superv (27-1 PU CS)	27/59 O/U Volt.	OUT	*	On Off		*	LED			BO	74	34	2	Yes	
6537	27-2 Undervoltage picked up (27-2 picked up)	27/59 O/U Volt.	OUT	*	On Off		*	LED			BO	74	37	2	Yes	
6538	27-2 Undervoltage PICKUP w/curr. superv (27-2 PU CS)	27/59 O/U Volt.	OUT	*	On Off		*	LED			BO	74	38	2	Yes	
6539	27-1 Undervoltage TRIP (27-1 TRIP)	27/59 O/U Volt.	OUT	*	on		m	LED			BO	74	39	2	Yes	
6540	27-2 Undervoltage TRIP (27-2 TRIP)	27/59 O/U Volt.	OUT	*	on		*	LED			BO	74	40	2	Yes	
6565	59-Overvoltage protection switched OFF (59 OFF)	27/59 O/U Volt.	OUT	On Off	*		*	LED			BO	74	65	1	Yes	
6566	59-Overvoltage protection is BLOCKED (59 BLOCKED)	27/59 O/U Volt.	OUT	On Off	On Off		*	LED			BO	74	66	1	Yes	
6567	59-Overvoltage protection is ACTIVE (59 ACTIVE)	27/59 O/U Volt.	OUT	On Off	*		*	LED			BO	74	67	1	Yes	
6568	59-1 Overvoltage V> picked up (59-1 picked up)	27/59 O/U Volt.	OUT	*	On Off		*	LED			BO	74	68	2	Yes	
6570	59-1 Overvoltage V> TRIP (59-1 TRIP)	27/59 O/U Volt.	OUT	*	on		m	LED			BO	74	70	2	Yes	
6571	59-2 Overvoltage V>> picked up (59-2 picked up)	27/59 O/U Volt.	OUT	*	On Off		*	LED			BO					
6573	59-2 Overvoltage V>> TRIP (59-2 TRIP)	27/59 O/U Volt.	OUT	*	on		*	LED			BO					

No.	Description	Function	Type of Information	Log Buffers				Configurable in Matrix					IEC 60870-5-103				
				Event Log ON/OFF	Trip (Fault) Log ON/OFF	Ground Fault Log ON/OFF	Marked in Oscill. Record	LED	Binary Input	Function Key	Relay	Chatter Suppression	Type	Information Number	Data Unit	General Interrogation	
6851	>BLOCK 74TC (>BLOCK 74TC)	74TC TripCirc.	SP	*	*		*	LED	BI		BO						
6852	>74TC Trip circuit superv.: trip relay (>74TC trip rel.)	74TC TripCirc.	SP	On Off	*		*	LED	BI		BO		170	51	1	Yes	
6853	>74TC Trip circuit superv.: bkr relay (>74TC brk rel.)	74TC TripCirc.	SP	On Off	*		*	LED	BI		BO		170	52	1	Yes	
6861	74TC Trip circuit supervision OFF (74TC OFF)	74TC TripCirc.	OUT	On Off	*		*	LED			BO		170	53	1	Yes	
6862	74TC Trip circuit supervision is BLOCKED (74TC BLOCKED)	74TC TripCirc.	OUT	On Off	On Off		*	LED			BO		153	16	1	Yes	
6863	74TC Trip circuit supervision is ACTIVE (74TC ACTIVE)	74TC TripCirc.	OUT	On Off	*		*	LED			BO		153	17	1	Yes	
6864	74TC blocked. Bin. input is not set (74TC ProgFail)	74TC TripCirc.	OUT	On Off	*		*	LED			BO		170	54	1	Yes	
6865	74TC Failure Trip Circuit (74TC Trip cir.)	74TC TripCirc.	OUT	On Off	*		*	LED			BO		170	55	1	Yes	
6903	>block interm. E/F prot. (>IEF block)	Intermit. EF	SP	*	*		*	LED	BI		BO		152	1	1	Yes	
6921	Interm. E/F prot. is switched off (IEF OFF)	Intermit. EF	OUT	On Off	*		*	LED			BO		152	10	1	Yes	
6922	Interm. E/F prot. is blocked (IEF blocked)	Intermit. EF	OUT	On Off	On Off		*	LED			BO		152	11	1	Yes	
6923	Interm. E/F prot. is active (IEF enabled)	Intermit. EF	OUT	On Off	*		*	LED			BO		152	12	1	Yes	
6924	Interm. E/F detection stage lie> (IIE Fault det)	Intermit. EF	OUT	*	*		*	LED			BO						
6925	Interm. E/F stab detection (IIE stab.Flt)	Intermit. EF	OUT	*	*		*	LED			BO						
6926	Interm.E/F det.stage lie> f.Flt. ev.Prot (IIE Flt.det FE)	Intermit. EF	OUT	*	on		*						152	13	2	No	
6927	Interm. E/F detected (Intermitt.EF)	Intermit. EF	OUT	*	On Off		*	LED			BO		152	14	2	Yes	
6928	Counter of det. times elapsed (IEF Tsum exp.)	Intermit. EF	OUT	*	on		*	LED			BO		152	15	2	No	
6929	Interm. E/F: reset time running (IEF Tres run.)	Intermit. EF	OUT	*	On Off		*	LED			BO		152	16	2	Yes	
6930	Interm. E/F: trip (IEF Trip)	Intermit. EF	OUT	*	on		*	LED			BO		152	17	2	No	
6931	Max RMS current value of fault = (lie/In=)	Intermit. EF	VI		On Off		*						152	18	4	No	
6932	No. of detections by stage lie>= (Nos.IIE=)	Intermit. EF	VI		On Off		*						152	19	4	No	
6951	>Block directional interm. E/F prot. (>dIEF block)	Dir. Interm. EF	SP	On Off	*	*	*	LED	BI		BO						
6961	Dir. Interm. E/F prot. is switched off (dIEF OFF)	Dir. Interm. EF	OUT	On Off	*	*	*	LED			BO						
6962	Dir. Interm. E/F prot. is blocked (dIEF blocked)	Dir. Interm. EF	OUT	On Off	*	*	*	LED	BI		BO						
6963	Dir. Interm. E/F prot. is active (dIEF active)	Dir. Interm. EF	OUT	On Off	*	*	*	LED	BI		BO						
6972	dIEF: pick up (dIEF pick up)	Dir. Interm. EF	OUT	*	On Off	On Off	*	LED			BO						
6973	dIEF: Trip (dIEF TRIP)	Dir. Interm. EF	OUT	*	on	On Off	*	LED			BO						
6974	dIEF: No. of detected forward pulses = (No.forward=)	Dir. Interm. EF	VI	*	On Off	On Off											
6975	dIEF: No. of detected reverse pulses = (No.reverse=)	Dir. Interm. EF	VI	*	On Off	On Off											

Appendix
A.9 Information List

No.	Description	Function	Type of Information	Log Buffers				Configurable in Matrix					IEC 60870-5-103				
				Event Log ON/OFF	Trip (Fault) Log ON/OFF	Ground Fault Log ON/OFF	Marked in Oscill. Record	LED	Binary Input	Function Key	Relay	Chatter Suppression	Type	Information Number	Data Unit	General Interrogation	
6976	dIEF: No. of detected undefined pulses = (No.undef.=)	Dir. Intern. EF	VI	*	On Off	On Off											
6979	dIEF: Alarm (dIEF ALARM)	Dir. Intern. EF	OUT	*	On Off	On Off	*	LED			BO						
7551	50-1 InRush picked up (50-1 InRushPU)	50/51 Overcur.	OUT	*	On Off		*	LED			BO	60	80	2	Yes		
7552	50N-1 InRush picked up (50N-1 InRushPU)	50/51 Overcur.	OUT	*	On Off		*	LED			BO	60	81	2	Yes		
7553	51 InRush picked up (51 InRush-PU)	50/51 Overcur.	OUT	*	On Off		*	LED			BO	60	82	2	Yes		
7554	51N InRush picked up (51N InRushPU)	50/51 Overcur.	OUT	*	On Off		*	LED			BO	60	83	2	Yes		
7556	InRush OFF (InRush OFF)	50/51 Overcur.	OUT	On Off	*		*	LED			BO	60	92	1	Yes		
7557	InRush BLOCKED (InRush BLK)	50/51 Overcur.	OUT	On Off	On Off		*	LED			BO	60	93	1	Yes		
7558	InRush Ground detected (InRush Gnd Det)	50/51 Overcur.	OUT	*	On Off		*	LED			BO	60	94	2	Yes		
7559	67-1 InRush picked up (67-1 InRushPU)	50/51 Overcur.	OUT	*	On Off		*	LED			BO	60	84	2	Yes		
7560	67N-1 InRush picked up (67N-1 InRushPU)	50/51 Overcur.	OUT	*	On Off		*	LED			BO	60	85	2	Yes		
7561	67-TOC InRush picked up (67-TOC InRushPU)	50/51 Overcur.	OUT	*	On Off		*	LED			BO	60	86	2	Yes		
7562	67N-TOC InRush picked up (67N-TOC InRushPU)	50/51 Overcur.	OUT	*	On Off		*	LED			BO	60	87	2	Yes		
7563	>BLOCK InRush (>BLOCK InRush)	50/51 Overcur.	SP	*	*		*	LED	BI		BO						
7564	Ground InRush picked up (Gnd InRush PU)	50/51 Overcur.	OUT	*	On Off		*	LED			BO	60	88	2	Yes		
7565	Phase A InRush picked up (Ia InRush PU)	50/51 Overcur.	OUT	*	On Off		*	LED			BO	60	89	2	Yes		
7566	Phase B InRush picked up (Ib InRush PU)	50/51 Overcur.	OUT	*	On Off		*	LED			BO	60	90	2	Yes		
7567	Phase C InRush picked up (Ic InRush PU)	50/51 Overcur.	OUT	*	On Off		*	LED			BO	60	91	2	Yes		
10034	50-3 BLOCKED (50-3 BLOCKED)	50/51 Overcur.	OUT	On Off	On Off		*	LED			BO	60	169	1	Yes		
10035	50N-3 BLOCKED (50N-3 BLOCKED)	50/51 Overcur.	OUT	On Off	On Off		*	LED			BO	60	170	1	Yes		
10036	Malparameteriz. Volt.-divider Capacities (Capac.Par.Fail.)	P.System Data 1	OUT	On Off				LED			BO						
10080	Error Extension I/O (Error Ext I/O)	Device, General	OUT	On Off	*		*	LED			BO						
10081	Error Ethernet (Error Ethernet)	Device, General	OUT	On Off	*		*	LED			BO						
10082	Error Current Terminal (Error Terminal)	Device, General	OUT	On Off	*		*	LED			BO						
10083	Error Basic I/O (Error Basic I/O)	Device, General	OUT	On Off	*		*	LED			BO						
16001	Sum Current Exponentiation Ph A to Ir ^x (ΣI ^x A=)	Statistics	VI														
16002	Sum Current Exponentiation Ph B to Ir ^x (ΣI ^x B=)	Statistics	VI														
16003	Sum Current Exponentiation Ph C to Ir ^x (ΣI ^x C=)	Statistics	VI														

No.	Description	Function	Type of Information	Log Buffers				Configurable in Matrix					IEC 60870-5-103				
				Event Log ON/OFF	Trip (Fault) Log ON/OFF	Ground Fault Log ON/OFF	Marked in Oscill. Record	LED	Binary Input	Function Key	Relay	Chatter Suppression	Type	Information Number	Data Unit	General Interrogation	
16005	Threshold Sum Curr. Exponent. exceeded (Threshold $\Sigma I^2 x >$)	SetPoint(Stat)	OUT	On Off	*		*	LED			BO						
16006	Residual Endurance Phase A (Resid.Endu. A=)	Statistics	VI														
16007	Residual Endurance Phase B (Resid.Endu. B=)	Statistics	VI														
16008	Residual Endurance Phase C (Resid.Endu. C=)	Statistics	VI														
16010	Dropped below Threshold CB Res.Endurance (Thresh.R.Endu.<)	SetPoint(Stat)	OUT	On Off	*		*	LED			BO						
16011	Number of mechanical Trips Phase A (mechan.TRIP A=)	Statistics	VI														
16012	Number of mechanical Trips Phase B (mechan.TRIP B=)	Statistics	VI														
16013	Number of mechanical Trips Phase C (mechan.TRIP C=)	Statistics	VI														
16014	Sum Squared Current Integral Phase A ($\Sigma I^2 t A =$)	Statistics	VI														
16015	Sum Squared Current Integral Phase B ($\Sigma I^2 t B =$)	Statistics	VI														
16016	Sum Squared Current Integral Phase C ($\Sigma I^2 t C =$)	Statistics	VI														
16018	Threshold Sum Squa. Curr. Int. exceeded (Thresh. $\Sigma I^2 t >$)	SetPoint(Stat)	OUT	On Off	*		*	LED			BO						
16019	>52 Breaker Wear Start Criteria (>52 Wear start)	P.System Data 2	SP	On Off	*		*	LED	BI		BO						
16020	52 Wear blocked by Time Setting Failure (52 WearSet.fail)	P.System Data 2	OUT	On Off	*		*	LED			BO						
16027	52 Breaker Wear Logic blk Ir-CB>=Isc-CB (52WL.blk I PErr)	P.System Data 2	OUT	On Off	*		*	LED			BO						
16028	52 Breaker W.Log.blk SwCyc.Isc>=SwCyc.Ir (52WL.blk n PErr)	P.System Data 2	OUT	On Off	*		*	LED			BO						
16029	Sens.gnd.flt. 51Ns BLOCKED Setting Error (51Ns BLK PaErr)	Sens. Gnd Fault	OUT	On Off	*		*	LED			BO						
16030	Angle between 3Vo and INs. ($\varphi(3Vo, INs) =$)	Sens. Gnd Fault	VI			On Off											
18420	>Trip via Binary Input (>Trip via BI)	P.System Data 2	SP	On Off	*		*	LED	BI		BO						
18421	Trip via GOOSE (Trip via GOOSE)	P.System Data 2	ExSP	On Off			*	LED			BO						
18422	81V 27V1 picked up (81V 27V1 pickup)	81 O/U Freq.	OUT	On Off	On Off		*	LED			BO						
18423	Direct Trip (Direct Trip)	P.System Data 2	OUT	*	on		m	LED			BO						
18424	PI Trip NC(ON,if Device ok & No Trip) (PI Trip NC)	P.System Data 2	OUT	On Off	On Off		m	LED			BO						
18425	>DDI Open status (>DDI Open)	P.System Data 2	SP	On Off	*		*	LED	BI		BO						
18426	>BLOCK 27.S1 Undervoltage protection	27/59 O/U Volt.	SP	On Off	*		*	LED	BI		BO						
18427	>BLOCK 27.S2 Undervoltage protection	27/59 O/U Volt.	SP	On Off	*		*	LED	BI		BO						
18428	27.S1 Undervoltage TRIP	27/59 O/U Volt.	OUT	*	on		m	LED			BO						
18430	27.S1 Undervoltage picked up	27/59 O/U Volt.	OUT	*	On Off		*	LED			BO						

Appendix
A.9 Information List

No.	Description	Function	Type of Information	Log Buffers				Configurable in Matrix					IEC 60870-5-103				
				Event Log ON/OFF	Trip (Fault) Log ON/OFF	Ground Fault Log ON/OFF	Marked in Oscill. Record	LED	Binary Input	Function Key	Relay	Chatter Suppression	Type	Information Number	Data Unit	General Interrogation	
18431	27.S2 Undervoltage TRIP	27/59 O/U Volt.	OUT	*	on		m	LED			BO						
18433	27.S2 Undervoltage picked up	27/59 O/U Volt.	OUT	*	On Off		*	LED			BO						
18434	59.S1 Overvoltage TRIP	27/59 O/U Volt.	OUT	*	on		m	LED			BO						
18435	59.S1 Overvoltage picked up	27/59 O/U Volt.	OUT	*	On Off		*	LED			BO						
18436	59.S2 Overvoltage TRIP	27/59 O/U Volt.	OUT	*	on		m	LED			BO						
18437	59.S2 Overvoltage picked up	27/59 O/U Volt.	OUT	*	On Off		*	LED			BO						
18438	>BLOCK 81>.S1 (>BLOCK 81>.S1)	81 O/U Freq.	SP	On Off	*		*	LED	BI		BO						
18439	>BLOCK 81<.S1 (>BLOCK 81<.S1)	81 O/U Freq.	SP	On Off	*		*	LED	BI		BO						
18440	>BLOCK 81>.S2 (>BLOCK 81>.S2)	81 O/U Freq.	SP	On Off	*		*	LED	BI		BO						
18441	>BLOCK 81<.S2 (>BLOCK 81<.S2)	81 O/U Freq.	SP	On Off	*		*	LED	BI		BO						
18442	81 Under Voltage Block Phase A/AB (81 V< Blk A/AB)	81 O/U Freq.	OUT	On Off	On Off		*	LED			BO						
18443	81 Under Voltage Block Phase B/BC (81 V< Blk B/BC)	81 O/U Freq.	OUT	On Off	On Off		*	LED			BO						
18445	81>.S1 picked up (81>.S1 pickup)	81 O/U Freq.	OUT	*	On Off		*	LED			BO						
18446	81>.S1 TRIP (81>.S1 TRIP)	81 O/U Freq.	OUT	*	on		m	LED			BO						
18448	81<.S1 picked up (81<.S1 pickup)	81 O/U Freq.	OUT	*	On Off		*	LED			BO						
18449	81<.S1 TRIP (81<.S1 TRIP)	81 O/U Freq.	OUT	*	on		m	LED			BO						
18451	81>.S2 picked up (81>.S2 pickup)	81 O/U Freq.	OUT	*	On Off		*	LED			BO						
18452	81>.S2 TRIP (81>.S2 TRIP)	81 O/U Freq.	OUT	*	on		m	LED			BO						
18454	81<.S2 picked up (81<.S2 pickup)	81 O/U Freq.	OUT	*	On Off		*	LED			BO						
18455	81<.S2 TRIP (81<.S2 TRIP)	81 O/U Freq.	OUT	*	on		m	LED			BO						
18457	81V 59V2 picked up (81V 59V2 pickup)	81 O/U Freq.	OUT	On Off	On Off		*	LED			BO						
18458	59V0 TRIP (59V0 TRIP)	81 O/U Freq.	OUT	*	on		m	LED			BO						
18459	59V0 picked up (59V0 pickup)	81 O/U Freq.	OUT	*	On Off		*	LED			BO						
18460	81.S1 Released (81.S1 Released)	81 O/U Freq.	OUT	On Off	On Off		*	LED			BO						
18461	27 Undervoltage protection switched OFF	27/59 O/U Volt.	OUT	On Off	*		*	LED			BO						
18462	27 Undervoltage protection is BLOCKED	27/59 O/U Volt.	OUT	On Off	On Off		*	LED			BO						
18463	27 Undervoltage protection is ACTIVE	27/59 O/U Volt.	OUT	On Off	*		*	LED			BO						
18464	59-Overvoltage protection switched OFF	27/59 O/U Volt.	OUT	On Off	*		*	LED			BO						
18465	59-Overvoltage protection is BLOCKED	27/59 O/U Volt.	OUT	On Off	On Off		*	LED			BO						
18466	59-Overvoltage protection is ACTIVE	27/59 O/U Volt.	OUT	On Off	*		*	LED			BO						
18467	81 Frequency protection switched OFF (81 OFF)	81 O/U Freq.	OUT	On Off	*		*	LED			BO						

No.	Description	Function	Type of Information	Log Buffers				Configurable in Matrix					IEC 60870-5-103				
				Event Log ON/OFF	Trip (Fault) Log ON/OFF	Ground Fault Log ON/OFF	Marked in Oscill. Record	LED	Binary Input	Function Key	Relay	Chatter Suppression	Type	Information Number	Data Unit	General Interrogation	
18468	81 Frequency protection is BLOCKED (81 BLOCKED)	81 O/U Freq.	OUT	On Off	On Off		*	LED			BO						
18469	81 Frequency protection is ACTIVE (81 ACTIVE)	81 O/U Freq.	OUT	On Off	*		*	LED			BO						
18476	59V0 BLOCKED (59V0 BLOCKED)	81 O/U Freq.	OUT	On Off	On Off		*	LED			BO						
30053	Fault recording is running (Fault rec. run.)	Osc. Fault Rec.	OUT	*	*		*	LED			BO						
31000	Q0 operationcounter= (Q0 OpCnt=)	Control Device	VI	*													
31001	Q1 operationcounter= (Q1 OpCnt=)	Control Device	VI	*													
31008	Q8 operationcounter= (Q8 OpCnt=)	Control Device	VI	*													

A.10 Group Alarms

No.	Description	Function No.	Description
140	Error Sum Alarm	177 178 10080 10081 10082 10083 191 193	Fail Battery I/O-Board error Error Ext I/O Error Ethernet Error Terminal Error Basic I/O Error Offset Alarm NO calibr
160	Alarm Sum Event	162 163 167 175 176	Failure Σ I Fail I balance Fail V balance Fail Ph. Seq. I Fail Ph. Seq. V
161	Fail I Superv.	162 163	Failure Σ I Fail I balance
171	Fail Ph. Seq.	175 176	Fail Ph. Seq. I Fail Ph. Seq. V

No.	Description	Function No.	Description
501	Relay PICKUP	1517 5159 5165 5166 5971 5974 5977 1761 2691 1224 1221 1227 1215 6972 6423 235.2121 5232 5233 5234 5235 18445 18448 18451 18454 18459 6533 6534 6537 6538 6568 6571 18430 18433 18435 18437 1456 1457	49 Winding O/L 46-2 picked up 46-1 picked up 46-TOC pickedup 50 1Ph Pickup 50 1Ph-1 PU 50 1Ph-2 PU 50(N)/51(N) PU 67/67N pickedup 50Ns-1 Pickup 50Ns-2 Pickup 51Ns Pickup 64 Pickup dIEF pick up 27/Q PICKUP \$00 picked up 81-1 picked up 81-2 picked up 81-3 picked up 81-4 picked up 81>.S1 pickup 81<.S1 pickup 81>.S2 pickup 81<.S2 pickup 59V0 pickup 27-1 picked up 27-1 PU CS 27-2 picked up 27-2 PU CS 59-1 picked up 59-2 picked up 27.S1 picked up 27.S2 picked up 59.S1 picked up 59.S2 picked up 50BF int Pickup 50BF ext Pickup

No.	Description	Function No.	Description
511	Relay TRIP	1521	49 Th O/L TRIP
		5170	46 TRIP
		5972	50 1Ph TRIP
		5975	50 1Ph-1 TRIP
		5979	50 1Ph-2 TRIP
		1791	50(N)/51(N)TRIP
		2696	67/67N TRIP
		1226	50Ns-1 TRIP
		1223	50Ns-2 TRIP
		1229	50Ns TRIP
		1217	64 TRIP
		6930	IEF Trip
		6973	dIEF TRIP
		235.2126	\$00 TRIP
		5236	81-1 TRIP
		5237	81-2 TRIP
		5238	81-3 TRIP
		5239	81-4 TRIP
		18446	81>.S1 TRIP
		18449	81<.S1 TRIP
		18452	81>.S2 TRIP
		18455	81<.S2 TRIP
		18458	59V0 TRIP
		18424	PI Trip NC
		18423	Direct Trip
		6539	27-1 TRIP
		6540	27-2 TRIP
		6570	59-1 TRIP
		6573	59-2 TRIP
		18428	27.S1 TRIP
		18431	27.S2 TRIP
		18434	59.S1 TRIP
		18436	59.S2 TRIP
		1471	50BF TRIP

A.11 Measured Values

No.	Description	Function	IEC 60870-5-103					Configurable in Matrix		
			Type	Information Number	Compatibility	Data Unit	Position	CFC	Control Display	Default Display
-	Number of TRIPs= (#of TRIPs=)	Statistics	-	-	-	-	-	CFC		
-	Operating hours greater than (OpHour>)	SetPoint(Stat)	-	-	-	-	-	CFC		
170.2050	V1 = (V1 =)	SYNC function 1	130	1	No	9	1	CFC		
170.2051	f1 = (f1 =)	SYNC function 1	130	1	No	9	4	CFC		
170.2052	V2 = (V2 =)	SYNC function 1	130	1	No	9	3	CFC		
170.2053	f2 = (f2 =)	SYNC function 1	130	1	No	9	7	CFC		
170.2054	dV = (dV =)	SYNC function 1	130	1	No	9	2	CFC		
170.2055	df = (df =)	SYNC function 1	130	1	No	9	5	CFC		
170.2056	alpha = (dα =)	SYNC function 1	130	1	No	9	6	CFC		
601	Ia (Ia =)	Measurement	134	157	No	9	1	CFC		
602	Ib (Ib =)	Measurement	160	145	Yes	3	1	CFC		
			134	157	No	9	2			
603	Ic (Ic =)	Measurement	134	157	No	9	3	CFC		
604	In (In =)	Measurement	134	157	No	9	4	CFC		
605	I1 (positive sequence) (I1 =)	Measurement	-	-	-	-	-	CFC		
606	I2 (negative sequence) (I2 =)	Measurement	-	-	-	-	-	CFC		
621	Va (Va =)	Measurement	134	157	No	9	6	CFC		
622	Vb (Vb =)	Measurement	134	157	No	9	7	CFC		
623	Vc (Vc =)	Measurement	134	157	No	9	8	CFC		
624	Va-b (Va-b=)	Measurement	160	145	Yes	3	2	CFC		
			134	157	No	9	9			
625	Vb-c (Vb-c=)	Measurement	134	157	No	9	10	CFC		
626	Vc-a (Vc-a=)	Measurement	134	157	No	9	11	CFC		
18473	Va-b RMS(10 minute RMS value) (Va-b RMS=)	Measurement	-	-	-	-	-	CFC		
18474	Vb-c RMS(10 minute RMS value) (Vb-c RMS=)	Measurement	-	-	-	-	-	CFC		
18475	Vc-a RMS(10 minute RMS value) (Vc-a RMS=)	Measurement	-	-	-	-	-	CFC		
627	VN (VN =)	Measurement	134	118	No	9	1	CFC		
629	V1 (positive sequence) (V1 =)	Measurement	-	-	-	-	-	CFC		
630	V2 (negative sequence) (V2 =)	Measurement	-	-	-	-	-	CFC		
632	Vsync (synchronism) (Vsync =)	Measurement	-	-	-	-	-	CFC		
641	P (active power) (P =)	Measurement	134	157	No	9	12	CFC		
642	Q (reactive power) (Q =)	Measurement	134	157	No	9	13	CFC		
644	Frequency (Freq=)	Measurement	134	157	No	9	5	CFC		
645	S (apparent power) (S =)	Measurement	-	-	-	-	-	CFC		
680	Angle Va-Ia (Phi A =)	Measurement	-	-	-	-	-	CFC		
681	Angle Vb-Ib (Phi B =)	Measurement	-	-	-	-	-	CFC		
682	Angle Vc-Ic (Phi C =)	Measurement	-	-	-	-	-	CFC		
701	Resistive ground current in isol systems (INs Real)	Measurement	134	157	No	9	15	CFC		
702	Reactive ground current in isol systems (INs Reac)	Measurement	134	157	No	9	16	CFC		
807	Thermal Overload (θ/θtrip)	Measurement	-	-	-	-	-	CFC		
830	INs Sensitive Ground Fault Current (INs =)	Measurement	134	158	No	9	1	CFC		

No.	Description	Function	IEC 60870-5-103					Configurable in Matrix		
			Type	Information Number	Compatibility	Data Unit	Position	CFC	Control Display	Default Display
831	3Io (zero sequence) (3Io =)	Measurement	-	-	-	-	-	CFC		
832	Vo (zero sequence) (Vo =)	Measurement	134	118	No	9	2	CFC		
833	I1 (positive sequence) Demand (I1 dmd=)	Demand meter	-	-	-	-	-	CFC		
834	Active Power Demand (P dmd =)	Demand meter	-	-	-	-	-	CFC		
835	Reactive Power Demand (Q dmd =)	Demand meter	-	-	-	-	-	CFC		
836	Apparent Power Demand (S dmd =)	Demand meter	-	-	-	-	-	CFC		
837	I A Demand Minimum (IAdmdMin)	Min/Max meter	-	-	-	-	-	CFC		
838	I A Demand Maximum (IAdmdMax)	Min/Max meter	-	-	-	-	-	CFC		
839	I B Demand Minimum (IBdmdMin)	Min/Max meter	-	-	-	-	-	CFC		
840	I B Demand Maximum (IBdmdMax)	Min/Max meter	-	-	-	-	-	CFC		
841	I C Demand Minimum (ICdmdMin)	Min/Max meter	-	-	-	-	-	CFC		
842	I C Demand Maximum (ICdmdMax)	Min/Max meter	-	-	-	-	-	CFC		
843	I1 (positive sequence) Demand Minimum (I1dmdMin)	Min/Max meter	-	-	-	-	-	CFC		
844	I1 (positive sequence) Demand Maximum (I1dmdMax)	Min/Max meter	-	-	-	-	-	CFC		
845	Active Power Demand Minimum (PdMin=)	Min/Max meter	-	-	-	-	-	CFC		
846	Active Power Demand Maximum (PdMax=)	Min/Max meter	-	-	-	-	-	CFC		
847	Reactive Power Minimum (QdMin=)	Min/Max meter	-	-	-	-	-	CFC		
848	Reactive Power Maximum (QdMax=)	Min/Max meter	-	-	-	-	-	CFC		
849	Apparent Power Minimum (SdMin=)	Min/Max meter	-	-	-	-	-	CFC		
850	Apparent Power Maximum (SdMax=)	Min/Max meter	-	-	-	-	-	CFC		
851	Ia Min (Ia Min=)	Min/Max meter	-	-	-	-	-	CFC		
852	Ia Max (Ia Max=)	Min/Max meter	-	-	-	-	-	CFC		
853	Ib Min (Ib Min=)	Min/Max meter	-	-	-	-	-	CFC		
854	Ib Max (Ib Max=)	Min/Max meter	-	-	-	-	-	CFC		
855	Ic Min (Ic Min=)	Min/Max meter	-	-	-	-	-	CFC		
856	Ic Max (Ic Max=)	Min/Max meter	-	-	-	-	-	CFC		
857	I1 (positive sequence) Minimum (I1 Min=)	Min/Max meter	-	-	-	-	-	CFC		
858	I1 (positive sequence) Maximum (I1 Max=)	Min/Max meter	-	-	-	-	-	CFC		
859	Va-n Min (Va-nMin=)	Min/Max meter	-	-	-	-	-	CFC		
860	Va-n Max (Va-nMax=)	Min/Max meter	-	-	-	-	-	CFC		
861	Vb-n Min (Vb-nMin=)	Min/Max meter	-	-	-	-	-	CFC		
862	Vb-n Max (Vb-nMax=)	Min/Max meter	-	-	-	-	-	CFC		
863	Vc-n Min (Vc-nMin=)	Min/Max meter	-	-	-	-	-	CFC		
864	Vc-n Max (Vc-nMax=)	Min/Max meter	-	-	-	-	-	CFC		
865	Va-b Min (Va-bMin=)	Min/Max meter	-	-	-	-	-	CFC		
866	Va-b Max (Va-bMax=)	Min/Max meter	-	-	-	-	-	CFC		
867	Vb-c Min (Vb-cMin=)	Min/Max meter	-	-	-	-	-	CFC		
868	Vb-c Max (Vb-cMax=)	Min/Max meter	-	-	-	-	-	CFC		
869	Vc-a Min (Vc-aMin=)	Min/Max meter	-	-	-	-	-	CFC		
870	Vc-a Max (Vc-aMax=)	Min/Max meter	-	-	-	-	-	CFC		
871	V neutral Min (Vn Min =)	Min/Max meter	-	-	-	-	-	CFC		
872	V neutral Max (Vn Max =)	Min/Max meter	-	-	-	-	-	CFC		
873	V1 (positive sequence) Voltage Minimum (V1 Min =)	Min/Max meter	-	-	-	-	-	CFC		
874	V1 (positive sequence) Voltage Maximum (V1 Max =)	Min/Max meter	-	-	-	-	-	CFC		
875	Active Power Minimum (Pmin=)	Min/Max meter	-	-	-	-	-	CFC		
876	Active Power Maximum (Pmax=)	Min/Max meter	-	-	-	-	-	CFC		

No.	Description	Function	IEC 60870-5-103					Configurable in Matrix		
			Type	Information Number	Compatibility	Data Unit	Position	CFC	Control Display	Default Display
878	Reactive Power Minimum (Qmin=)	Min/Max meter	-	-	-	-	-	CFC		
879	Reactive Power Maximum (Qmax=)	Min/Max meter	-	-	-	-	-	CFC		
880	Apparent Power Minimum (Smin=)	Min/Max meter	-	-	-	-	-	CFC		
881	Apparent Power Maximum (Smax=)	Min/Max meter	-	-	-	-	-	CFC		
882	Frequency Minimum (fmin=)	Min/Max meter	-	-	-	-	-	CFC		
883	Frequency Maximum (fmax=)	Min/Max meter	-	-	-	-	-	CFC		
884	Power Factor Maximum (PF Max=)	Min/Max meter	-	-	-	-	-	CFC		
885	Power Factor Minimum (PF Min=)	Min/Max meter	-	-	-	-	-	CFC		
888	Pulsed Energy Wp (active) (Wp(puls))	Energy	133	55	No	205	-	CFC		
889	Pulsed Energy Wq (reactive) (Wq(puls))	Energy	133	56	No	205	-	CFC		
901	Power Factor (PF =)	Measurement	134	157	No	9	14	CFC		
924	Wp Forward (WpForward)	Energy	133	51	No	205	-	CFC		
925	Wq Forward (WqForward)	Energy	133	52	No	205	-	CFC		
928	Wp Reverse (WpReverse)	Energy	133	53	No	205	-	CFC		
929	Wq Reverse (WqReverse)	Energy	133	54	No	205	-	CFC		
963	I A demand (Ia dmd=)	Demand meter	-	-	-	-	-	CFC		
964	I B demand (Ib dmd=)	Demand meter	-	-	-	-	-	CFC		
965	I C demand (Ic dmd=)	Demand meter	-	-	-	-	-	CFC		
1058	Overload Meter Max (Θ/Θ_{TrpMax})	Min/Max meter	-	-	-	-	-	CFC		
1059	Overload Meter Min (Θ/Θ_{TrpMin})	Min/Max meter	-	-	-	-	-	CFC		
16004	Threshold Sum Current Exponentiation (ΣI^x)	SetPoint(Stat)	-	-	-	-	-	CFC		
16009	Lower Threshold of CB Residual Endurance (Resid.Endu. <)	SetPoint(Stat)	-	-	-	-	-	CFC		
16017	Threshold Sum Squared Current Integral ($\Sigma I^2 t$)	SetPoint(Stat)	-	-	-	-	-	CFC		
16031	Angle between 3Vo and INsens. ($\varphi(3Vo, INs)$)	Measurement	-	-	-	-	-	CFC		
30701	Pa (active power, phase A) (Pa =)	Measurement	-	-	-	-	-	CFC		
30702	Pb (active power, phase B) (Pb =)	Measurement	-	-	-	-	-	CFC		
30703	Pc (active power, phase C) (Pc =)	Measurement	-	-	-	-	-	CFC		
30704	Qa (reactive power, phase A) (Qa =)	Measurement	-	-	-	-	-	CFC		
30705	Qb (reactive power, phase B) (Qb =)	Measurement	-	-	-	-	-	CFC		
30706	Qc (reactive power, phase C) (Qc =)	Measurement	-	-	-	-	-	CFC		
30707	Power Factor, phase A (PFa =)	Measurement	-	-	-	-	-	CFC		
30708	Power Factor, phase B (PFb =)	Measurement	-	-	-	-	-	CFC		
30709	Power Factor, phase C (PFc =)	Measurement	-	-	-	-	-	CFC		
30800	Voltage VX (VX =)	Measurement	-	-	-	-	-	CFC		
30801	Voltage phase-neutral (Vph-n =)	Measurement	-	-	-	-	-	CFC		



Literature

- /1/ SIPROTEC 4 System Description; E50417-H1176-C151-A1
- /2/ SIPROTEC DIGSI, Start UP; E50417-G1176-C152-A2
- /3/ DIGSI CFC, Manual; E50417-H1176-C098-A5
- /4/ SIPROTEC SIGRA 4, Manual; E50417-H1176-C070-A1
- /5/ Additional description for the protection of explosion-protected motors of protection type increased safety "e"; C53000-B1174-C170

Glossary

Battery

The buffer battery ensures that specified data areas, flags, timers and counters are retained retentively.

Bay controllers

Bay controllers are devices with control and monitoring functions without protective functions.

Bit pattern indication

Bit pattern indication is a processing function by means of which items of digital process information applying across several inputs can be detected together in parallel and processed further. The bit pattern length can be specified as 1, 2, 3 or 4 bytes.

BP_xx

→ Bit pattern indication (Bitstring Of x Bit), x designates the length in bits (8, 16, 24 or 32 bits).

C_xx

Command without feedback

CF_xx

Command with feedback

CFC

Continuous Function Chart. CFC is a graphics editor with which a program can be created and configured by using ready-made blocks.

CFC blocks

Blocks are parts of the user program delimited by their function, their structure or their purpose.

Chatter blocking

A rapidly intermittent input (for example, due to a relay contact fault) is switched off after a configurable monitoring time and can thus not generate any further signal changes. The function prevents overloading of the system when a fault arises.

Combination devices

Combination devices are bay devices with protection functions and a control display.

Combination matrix

DIGSI V4.6 and higher allows up to 32 compatible SIPROTEC 4 devices to communicate with each other in an inter-relay communication network (IRC). The combination matrix defines which devices exchange which information.

Communication branch

A communications branch corresponds to the configuration of 1 to n users which communicate by means of a common bus.

Communication reference CR

The communication reference describes the type and version of a station in communication by PROFIBUS.

Component view

In addition to a topological view, SIMATIC Manager offers you a component view. The component view does not offer any overview of the hierarchy of a project. It does, however, provide an overview of all the SIPROTEC 4 devices within a project.

COMTRADE

Common Format for Transient Data Exchange, format for fault records.

Container

If an object can contain other objects, it is called a container. The object Folder is an example of such a container.

Control display

The image which is displayed on devices with a large (graphic) display after pressing the control key is called control display. It contains the switchgear that can be controlled in the feeder with status display. It is used to perform switching operations. Defining this diagram is part of the configuration.

Data pane

→ The right-hand area of the project window displays the contents of the area selected in the → navigation window, for example indications, measured values, etc. of the information lists or the function selection for the device configuration.

DCF77

The extremely precise official time is determined in Germany by the "Physikalisch-Technischen-Bundesanstalt PTB" in Braunschweig. The atomic clock unit of the PTB transmits this time via the long-wave time-signal transmitter in Mainflingen near Frankfurt/Main. The emitted time signal can be received within a radius of approx. 1,500 km from Frankfurt/Main.

Device container

In the Component View, all SIPROTEC 4 devices are assigned to an object of type Device container. This object is a special object of DIGSI Manager. However, since there is no component view in DIGSI Manager, this object only becomes visible in conjunction with STEP 7.

Double command

Double commands are process outputs which indicate 4 process states at 2 outputs: 2 defined (for example ON/OFF) and 2 undefined states (for example intermediate positions)

Double-point indication

Double-point indications are items of process information which indicate 4 process states at 2 inputs: 2 defined (for example ON/OFF) and 2 undefined states (for example intermediate positions).

DP

→ Double-point indication

DP_I

→ Double point indication, intermediate position 00

Drag-and-drop

Copying, moving and linking function, used at graphics user interfaces. Objects are selected with the mouse, held and moved from one data area to another.

Electromagnetic compatibility

Electromagnetic compatibility (EMC) is the ability of an electrical apparatus to function fault-free in a specified environment without influencing the environment unduly.

EMC

→ Electromagnetic compatibility

ESD protection

ESD protection is the total of all the means and measures used to protect electrostatic sensitive devices.

ExBPxx

External bit pattern indication via an ETHERNET connection, device-specific → Bit pattern indication

ExC

External command without feedback via an ETHERNET connection, device-specific

ExCF

External command with feedback via an ETHERNET connection, device-specific

ExDP

External double point indication via an ETHERNET connection, device-specific → Double-point indication

ExDP_I

External double-point indication via an ETHERNET connection, intermediate position 00, → Double-point indication

ExMV

External metered value via an ETHERNET connection, device-specific

ExSI

External single-point indication via an ETHERNET connection, device-specific → Single-point indication

ExSI_F

External single point indication via an ETHERNET connection, device-specific, → Fleeting indication, → Single-point indication

Field devices

Generic term for all devices assigned to the field level: Protection devices, combination devices, bay controllers.

Floating

→ Without electrical connection to the → ground.

FMS communication branch

Within an FMS communication branch the users communicate on the basis of the PROFIBUS FMS protocol via a PROFIBUS FMS network.

Folder

This object type is used to create the hierarchical structure of a project.

General interrogation (GI)

During the system start-up the state of all the process inputs, of the status and of the fault image is sampled. This information is used to update the system-end process image. The current process state can also be sampled after a data loss by means of a GI.

GOOSE message

GOOSE messages (Generic Object Oriented Substation Event) in accordance with IEC 61850 are data packages that are transmitted cyclically and event-controlled via the Ethernet communication system. They serve for direct information exchange among the relays. This mechanism facilitates cross-communication between bay devices.

GPS

Global Positioning System. Satellites with atomic clocks on board orbit the earth twice a day in different parts in approx. 20,000 km. They transmit signals which also contain the GPS universal time. The GPS receiver determines its own position from the signals received. From its position it can derive the running time of a satellite and thus correct the transmitted GPS universal time.

Ground

The conductive ground whose electric potential can be set equal to zero in any point. In the area of ground electrodes the ground can have a potential deviating from zero. The term "Ground reference plane" is often used for this state.

Grounding

Grounding means that a conductive part is to connect via a grounding system to → ground.

Grounding

Grounding is the total of all means and measured used for grounding.

Hierarchy level

Within a structure with higher-level and lower-level objects a hierarchy level is a container of equivalent objects.

HV field description

The HV project description file contains details of fields which exist in a ModPara project. The actual field information of each field is memorized in an HV field description file. Within the HV project description file, each field is allocated such an HV field description file by a reference to the file name.

HV project description

All data are exported once the configuration and parameterization of PCUs and sub-modules using ModPara has been completed. This data is split up into several files. One file contains details about the fundamental project structure. This also includes, for example, information detailing which fields exist in this project. This file is called a HV project description file.

ID

Internal double-point indication → Double-point indication

ID_S

Internal double point indication intermediate position 00 → Double-point indication

IEC

International Electrotechnical Commission

IEC address

Within an IEC bus a unique IEC address has to be assigned to each SIPROTEC 4 device. A total of 254 IEC addresses are available for each IEC bus.

IEC communication branch

Within an IEC communication branch the users communicate on the basis of the IEC60-870-5-103 protocol via an IEC bus.

IEC61850

Worldwide communication standard for communication in substations. This standard allows devices from different manufacturers to interoperate on the station bus. Data transfer is accomplished through an Ethernet network.

Initialization string

An initialization string comprises a range of modem-specific commands. These are transmitted to the modem within the framework of modem initialization. The commands can, for example, force specific settings for the modem.

Inter relay communication

→ IRC combination

IRC combination

Inter Relay Communication, IRC, is used for directly exchanging process information between SIPROTEC 4 devices. You require an object of type IRC combination to configure an Inter Relay Communication. Each user of the combination and all the necessary communication parameters are defined in this object. The type and scope of the information exchanged among the users is also stored in this object.

IRIG-B

Time signal code of the Inter-Range Instrumentation Group

IS

Internal single-point indication → Single-point indication

IS_F

Internal indication fleeting → Fleeting indication, → Single-point indication

ISO 9001

The ISO 9000 ff range of standards defines measures used to ensure the quality of a product from the development to the manufacturing.

LFO filter

(Low Frequency Oscillation) Filter for low-frequency oscillation

Link address

The link address gives the address of a V3/V2 device.

List view

The right pane of the project window displays the names and icons of objects which represent the contents of a container selected in the tree view. Because they are displayed in the form of a list, this area is called the list view.

LV

Limit value

LVU

Limit value, user-defined

Master

Masters may send data to other users and request data from other users. DIGSI operates as a master.

Metered value

Metered values are a processing function with which the total number of discrete similar events (counting pulses) is determined for a period, usually as an integrated value. In power supply companies the electrical work is usually recorded as a metered value (energy purchase/supply, energy transportation).

MLFB

MLFB is the acronym of "MaschinenLesbare FabrikateBezeichnung" (machine-readable product designation). It is equivalent to the order number. The type and version of a SIPROTEC 4 device are coded in the order number.

Modem connection

This object type contains information on both partners of a modem connection, the local modem and the remote modem.

Modem profile

A modem profile consists of the name of the profile, a modem driver and may also comprise several initialization commands and a user address. You can create several modem profiles for one physical modem. To do so you need to link various initialization commands or user addresses to a modem driver and its properties and save them under different names.

Modems

Modem profiles for a modem connection are saved in this object type.

MV

Measured value

MVMV

Metered value which is formed from the measured value

MVT

Measured value with time

MVU

Measured value, user-defined

Navigation pane

The left pane of the project window displays the names and symbols of all containers of a project in the form of a folder tree.

Object

Each element of a project structure is called an object in DIGSI.

Object properties

Each object has properties. These might be general properties that are common to several objects. An object can also have specific properties.

Off-line

In offline mode a link with the SIPROTEC 4 device is not necessary. You work with data which are stored in files.

OI_F

Output indication fleeting → Transient information

On-line

When working in online mode, there is a physical link to a SIPROTEC 4 device which can be implemented in various ways. This link can be implemented as a direct connection, as a modem connection or as a PROFIBUS FMS connection.

OUT

Output indication

Parameter set

The parameter set is the set of all parameters that can be set for a SIPROTEC 4 device.

Phone book

User addresses for a modem connection are saved in this object type.

PMV

Pulse metered value

Process bus

Devices featuring a process bus interface can communicate directly with the SICAM HV modules. The process bus interface is equipped with an Ethernet module.

PROFIBUS

PROcess Field BUS, the German process and field bus standard, as specified in the standard EN 50170, Volume 2, PROFIBUS. It defines the functional, electrical, and mechanical properties for a bit-serial field bus.

PROFIBUS Address

Within a PROFIBUS network a unique PROFIBUS address has to be assigned to each SIPROTEC 4 device. A total of 254 PROFIBUS addresses are available for each PROFIBUS network.

Project

Content-wise, a project is the image of a real power supply system. Graphically, a project is represented by a number of objects which are integrated in a hierarchical structure. Physically, a project consists of a series of folders and files containing project data.

Protection devices

All devices with a protective function and no control display.

Reorganizing

Frequent addition and deletion of objects creates memory areas that can no longer be used. By cleaning up projects, you can release these memory areas. However, a clean up also reassigns the VD addresses. As a consequence, all SIPROTEC 4 devices need to be reinitialized.

RIO file

Relay data Interchange format by Omicron.

RSxxx interface

Serial interfaces RS232, RS422/485

SCADA Interface

Rear serial interface on the devices for connecting to a control system via IEC or PROFIBUS.

Service port

Rear serial interface on the devices for connecting DIGSI (for example, via modem).

Setting parameters

General term for all adjustments made to the device. Parameterization jobs are executed by means of DIGSI or, in some cases, directly on the device.

SI

→ Single point indication

SI_F

→ Single-point indication fleeting → Transient information, → Single-point indication

SICAM PAS (Power Automation System)

Substation control system: The range of possible configurations spans from integrated standalone systems (SICAM PAS and M&C with SICAM PAS CC on one computer) to separate hardware for SICAM PAS and SICAM PAS CC to distributed systems with multiple SICAM Station Units. The software is a modular system with basic and optional packages. SICAM PAS is a purely distributed system: the process interface is implemented by the use of bay units / remote terminal units.

SICAM Station Unit

The SICAM Station Unit with its special hardware (no fan, no rotating parts) and its Windows XP Embedded operating system is the basis for SICAM PAS.

SICAM WinCC

The SICAM WinCC operator control and monitoring system displays the condition of your network graphically, visualizes alarms and indications, archives the network data, allows to intervene manually in the process and manages the system rights of the individual employee.

Single command

Single commands are process outputs which indicate 2 process states (for example, ON/OFF) at one output.

Single point indication

Single indications are items of process information which indicate 2 process states (for example, ON/OFF) at one output.

SIPROTEC

The registered trademark SIPROTEC is used for devices implemented on system base V4.

SIPROTEC 4 device

This object type represents a real SIPROTEC 4 device with all the setting values and process data it contains.

SIPROTEC 4 variant

This object type represents a variant of an object of type SIPROTEC 4 device. The device data of this variant may well differ from the device data of the source object. However, all variants derived from the source object have the same VD address as the source object. For this reason, they always correspond to the same real SIPROTEC 4 device as the source object. Objects of type SIPROTEC 4 variant have a variety of uses, such as documenting different operating states when entering parameter settings of a SIPROTEC 4 device.

Slave

A slave may only exchange data with a master after being prompted to do so by the master. SIPROTEC 4 devices operate as slaves.

Time stamp

Time stamp is the assignment of the real time to a process event.

Topological view

DIGSI Manager always displays a project in the topological view. This shows the hierarchical structure of a project with all available objects.

Transformer Tap Indication

Transformer tap indication is a processing function on the DI by means of which the tap of the transformer tap changer can be detected together in parallel and processed further.

Transient information

A transient information is a brief transient → single-point indication at which only the coming of the process signal is detected and processed immediately.

Tree view

The left pane of the project window displays the names and symbols of all containers of a project in the form of a folder tree. This area is called the tree view.

TxTap

→ Transformer Tap Indication

User address

A user address comprises the name of the station, the national code, the area code and the user-specific phone number.

Users

DIGSI V4.6 and higher allows up to 32 compatible SIPROTEC 4 devices to communicate with each other in an inter-relay communication network. The individual participating devices are called users.

VD

A VD (Virtual Device) includes all communication objects and their properties and states that are used by a communication user through services. A VD can be a physical device, a module of a device or a software module.

VD address

The VD address is assigned automatically by DIGSI Manager. It exists only once in the entire project and thus serves to identify unambiguously a real SIPROTEC 4 device. The VD address assigned by DIGSI Manager must be transferred to the SIPROTEC 4 device in order to allow communication with DIGSI Device Editor.

VFD

A VFD (Virtual Field Device) includes all communication objects and their properties and states that are used by a communication user through services.

VI

Value Indication

Index

4

46-1, 46-2 160

A

Action Time 248
Alternating voltage 403
Analog Inputs 402
ATEX100 186
Automatic Reclosing 245
Automatic reclosing system 452
Automatic Reclosure Function 245
Auxiliary voltage 403

B

Binary inputs 403
Binary outputs 403
Blocking Time 249
Breaker Failure Protection 272
Breaker failure protection 454
Broken wire monitoring 199
Buffer battery 191
Busbar Protection 131
Busbar protection 136

C

Changing Setting Groups 58
Check: Circuit Breaker Failure Protection 387
Check: Phase Rotation 389
Check: Polarity for Current Input I_N 395
Check: Switching States of the Binary Inputs and Outputs 384
Check: System Connections 376
Checking: User-Defined Functions 388
Circuit Breaker Monitoring 252
Circuit breaker monitoring 468
Circuit Breaker Status Recognition 251
Climatic Stress Tests 409
Clock 468
Commissioning aids 468
Communication interfaces 404

Constructive designs 410
Cross Blocking 81
CT
 Knee-point voltage 134
Current Balance Monitoring 192
Current inputs 402
Current Symmetry Monitoring 194
Current Transformer
 Knee-point Voltage 129

D

Dead Time Start Delay 248
Definite-time overcurrent protection 411
Determination of Direction 104
Determination of Ground-faulted Phase 212, 218
Device-Specific CFC Blocks 461
Direct voltage 403
Directional intermittent ground fault protection 240, 451
Directional Inverse Time Overcurrent Elements 67-TOC, 67N-TOC 102
Directional overcurrent protection 424
Directional Overcurrent Protection Blocking by FFM 104
Directional Time Overcurrent Protection 67, 67N 96
Dynamic Blocking 250
Dynamic cold load pickup 427

E

Electrical tests 407
EMC tests for immunity (type tests) 407
EMC tests for noise emission (type test) 408
Energy counter 467

F

Fault Display
 Setting note 37
Fault Location 269
Fault location determination 269
Fault locator 453
 Double faults 269
Fault logging 467

Fault recording 56, 467
Fiber-optic Cables 375
Final Preparation of the Device 399
Flexible protection functions 455
Frequency Protection 167
Frequency protection 439
Function blocks 460
Fuse failure monitor 196

G

General Device Pickup 315
General diagrams 482
General tripping 316
Ground Fault 130, 130
Ground fault 136
 Measurement procedure $\cos \varphi$ 214
Ground Fault Check 394
Ground Fault Detection
 Current Element for $\cos\text{-}\varphi/\sin\text{-}\varphi$ 212
 Current Element for U0/10- φ 219
 Direction Determination for $\cos\text{-}\varphi/\sin\text{-}\varphi$ 213, 227
 Logic for $\cos\text{-}\varphi/\sin\text{-}\varphi$ 215
 Logic for U0/10- φ 220
 Tripping Range for U0/10- φ 219
 Voltage Element for $\cos\text{-}\varphi/\sin\text{-}\varphi$ 211
 Voltage Element for U0/10- φ 218
Ground fault detection
 Trip time delay at V0/I0 φ 229
Group switchover of the function parameters 469

H

Hardware monitoring 191
High impedance differential protection 132
High-impedance differential protection
 Sensitivity 134
 Stability conditions 133
Hours Meter "CB open" 320
Humidity 409

I

Inrush Restraint 104
Inrush restraint 104, 426
Insulation test 407
Interlocked Switching 345
Intermittent Ground Fault Protection 233
Intermittent ground fault protection 450
Inverse-time overcurrent protection 413

L

Limits for CFC blocks 462
 Limits for user-defined functions 462
 Line Sections 270
 Line sections 269
 Local measured value monitoring 467
 Long-term mean values 466

M

Malfunction responses of monitoring equipment 208
 Measured value monitoring 191
 Measuring voltage failure detection 196
 Mechanical tests 408
 Min./max. memory 466
 Monitoring of the Circuit Breaker Auxiliary Contacts 274
 Monitoring of the Current Flow 273

N

Negative sequence protection (definite-time characteristic) 432
 Negative sequence protection (inverse-time characteristics) 433
 Non-interlocked Switching 345

O

Offset Monitoring 194
 Operating hours counter 468
 Operational measured values 465
 Ordering data 476
 Output relays binary outputs 404
 Overcurrent protection
 1-phase 428
 Overcurrent Protection 50, 51, 50N, 51N
 Pickup value 132, 136
 Overcurrent protection ground current
 Frequency 428
 Overcurrent protection, 1-phase
 Current elements 428
 Dropout ratios 428
 Frequency 428
 Overfrequency 167
 Overload protection 185

P

Phase Sequence Monitoring 195
 Phase sequence reversal 313
 Pickup logic 315

Polarity Check for Current Input I_N 395
 Port A 404
 Port B 405

Q

QU protection 442

R

Reclosing Programs 248
 Recordings for Tests 397
 Regulations 407
 Reverse Interlocking Busbar Protection 84

S

Selection of Default Display
 Start page 37
 Sensitive Ground Fault Detection 211
 Sensitive ground fault detection 446
 Service conditions 409
 Software Monitoring 193
 Standard Interlocking 346
 Static Blocking 250
 Supply voltage 403
 Switchgear Control 341
 Switching authority 349
 Switching device control 470
 Switching mode 350
 Switching statistics 468
 Synchrocheck 458

T

Tank Leakage Protection 136
 Tank leakage protection 131
 Delay time 136
 Sensitivity 136
 Temperatures 409
 Terminal assignment 482
 Terminating the Trip Signal 316
 Test: system interface 379
 Test: Voltage transformer miniature circuit breaker (VT mcb) 389
 Thermal overload protection 444
 Time allocation 467
 Time overcurrent protection
 Transformer data 133
 Time Overcurrent Protection 50, 51, 50N, 51N
 Time Delay 132, 136

Time synchronization 468
Transformer
 Saturation Voltage 130
Triggering Oscillographic Recording 398
Trip circuit supervision 204, 468
Tripping Logic 316

U

Underfrequency 167
Undervoltage Consideration 78
User interface 404
User-defined functions 460

V

Vibration and shock stress during steady-state operation 408
Vibration and shock stress during transport 408
 voltage controlled 78
Voltage inputs 402
Voltage Limit 131
Voltage protection 429
Voltage supply 403
Voltage Symmetry 194
Voltage-restraint 78

W

Watchdog 193