

SIEMENS

Ingenuity for life

Analytical Products and Solutions

Standard Continuous Emissions Monitoring System (CEMS)

Specification Sheet

usa.siemens.com/analyticalproducts



Overview

The Standard CEMS is a low cost emissions monitoring package designed to operate in a general purpose, environmentally controlled shelter or cabinet. The targeted markets are NOX reduction sites at Refining, Hydrocarbon Processing and Chemical Plants. The standard monitoring requirements are based on the US EPA 1990 Clean Air Act as detailed in 40 CFR-Part 60, as well as local and state requirements. Special options are available for Part 75 monitoring upon request. The basic system is designed to monitor predefined ranges of nitrogen oxides, carbon monoxide and oxygen in process boilers and furnaces. The key features of the system are low maintenance and high uptime at an economical price.

Functional description

The system consists of two major components: the analysis rack and the sample probe box. The analysis rack contains Siemens analyzers, a Siemens system controller and a Sample Conditioning System. The probe box is mounted at the sample extraction point, usually on a stack or duct. The probe box is designed to extract and filter the hot wet sample from the stack or duct. The probe box also provides for calibration through the probe and blow back of probe filter. The filtered sample is then drawn to the analysis rack via a pump through a heated line for water removal by a chiller and quantification by the analyzers. The system is designed to measure pre-defined ranges of nitrogen oxides, carbon monoxide and oxygen.

The Oxides of Nitrogen analyzer is a Siemens Noxmat 600 CLD. This analyzer utilizes the principle of chemiluminescence for analyzing NO and NO₂ concentrations in a gaseous sample. The following ranges are offered:

- Nitrogen Oxide Ranges: 0-10 ppm
- 0-20 ppm
- 0-50 ppm
- 0-100 ppm
- 0-200 ppm
- 0-500 ppm

The Oxygen/Carbon Monoxide Analyzer is a Siemens ULTRAMAT/OXYMAT 6E. The OXYMAT 6 gas analyzer is based on the paramagnetic alternating pressure methodology. The ULTRAMAT 6 operates according to the NDIR two-beam alternating light principle. The following ranges are offered:

- Oxygen Range: 0-25%
- Carbon Monoxide Range: 0-100 ppm
- 0-200 ppm
- 0-500 ppm
- 0-1000 ppm

System Controller

The system controller is a Siemens S7 1200 PLC with Modbus TCP. It is used to control the day to day operation of the CEMS. It controls the daily automatic validation sequence and probe blow back sequence, and monitors the overall status of the system. The system controller is the primary interface for the system user.

Probe and filter assembly

The standard probe is 3' long 316 SS suitable for up to 1000° C maximum. The filter assembly is a 270S heated filter assembly (general purpose), 4" 150# RF flange 316SS NEMA 4X fiberglass enclosure.

Data Acquisition System (DAS)

The DAS is suitable for 40 CFR 60 and includes: 1 PC, local rack mount, industrial type, EMC station manager software for communications with a Siemens S7 1200 PLC.

Model Configurator

CEM-	AA	AB	AC	AD	-	AE	AF	AG	-	AH	-	AI	AJ	AK
■	AA	Base System												
■	AB	Carbon Monoxide / Oxygen Measuring Range												
■	AC	NOx Measuring Range												
■	AD	System Controller												
■	AE	Sample Extraction (Filter Assembly)												
■	AF	Sample Probe												
■	AG	Spool Piece												
■	AH	Sample Tubing												
■	AI	Sample Conditioning Scrubbers												
■	AJ	Sample Chillers												
■	AK	Data Acquisition System												

AA – Base Cabinet		
1.	NEMA Type 12, General purpose, open rack	Standard
2.	NEMA Type 12, General purpose, enclosed rack, w/ cabinet cooler	Consult Factory
3.	NEMA Type 12, Z-Purged for Div. 2, enclosed rack, w/cabinet cooler	Consult Factory

AB – Carbon Monoxide / Oxygen Measuring Range – ULTRAMAT/OXYMAT – Standard		
1.	0-100 PPM CO / 0-25% O ₂	
2.	0-200 PPM CO / 0-25% O ₂	
3.	0-500 PM CO / 0-25% O ₂	
4.	0-1000 PPM CO / 0-25% O ₂	

AC – NOx Measuring Range – NOXMAT Standard		
1.	0-10 PPM	
2.	0-20 PPM	
3.	0-50 PPM	
4.	0-100 PPM	
5.	0-200 PPM	
6.	0-500 PPM	

AD – System Controller - Standard		
1.	Siemens S7 1200 PLC Modbus TCP output	Standard
2.	Siemens S7 1200 PLC with digital and analog outputs	Consult factory

AE – Sample Extraction (Filter Assembly)		
1.	None	
2.	270S Heated Filter Assembly (General purpose), 4" 150# RF Flange 316 SST, NEMA 4X Fiberglass enclosure	Standard
3.	270S Heated Filter Assembly (General purpose), 2" 150# RF Flange 316 SST, NEMA 4X Fiberglass enclosure (included in base price)	Standard
4.	270S Heated Filter Assembly (General purpose), 3" 150# RF Flange 316 SST, NEMA 4X Fiberglass enclosure (included in base price)	Standard
5.	270S Heated Filter Assembly (Div. 2), 2" 150# RF Flange 316 SST, NEMA 4X Fiberglass enclosure	
6.	270S Heated Filter Assembly (Div. 2), 3" 150# RF Flange 316 SST, NEMA 4X Fiberglass enclosure	
7.	270S Heated Filter Assembly (Div. 2), 4" 150# RF Flange 316 SST, NEMA 4X Fiberglass enclosure	

AF – Sample Probe		
1.	None	
2.	3' Long, 316 SST Probe (Max. temp. 1000° F)	Standard
3.	Other materials or lengths	Consult factory

AG – Probe Spool Piece		
1.	None required < 700°F	Standard
2.	2" 150# RF Flange x 8" long painted carbon steel spool piece	
3.	3" 150# RF Flange x 8" long painted carbon steel spool piece	
4.	4" 150# RF Flange x 8" long painted carbon steel spool piece	

AH – Sample / Calibration Pre-insulated Tubing Bundle (includes RTD, RTD Installation and Termination Kits)		
1.	None	Standard
2.	Electrically traced bundle with PFA tubes for sample + spare, cal gas and blow back gas to maintain 250° F	

AI – Optional Sample Conditioning Scrubbers		
1.	None	Standard
2.	SO ₃ Scrubber only	
3.	NH ₃ Scrubber only	
4.	SO ₃ + NH ₃ Scrubber	

AJ – Sample Chillers		
1.	Sample Chiller 4° C	Standard
2.	Super Chiller – Minus 40°C, when SO ₂ present	

AK – Data Acquisition System (DAS)		
1.	None	Standard
2.	DAS – 40CFR60, includes – 1 PC, Local rack mount, Industrial type, EMC Station Manager Software for Communications with Siemens S7 1200 PLC	Consult factory
3.	DAS – 40CFR75	Consult factory
4.	Optional additional or remote DAS software license and connections	Consult factory

Contact your local Siemens Account Manager or Representative to help configure your system.

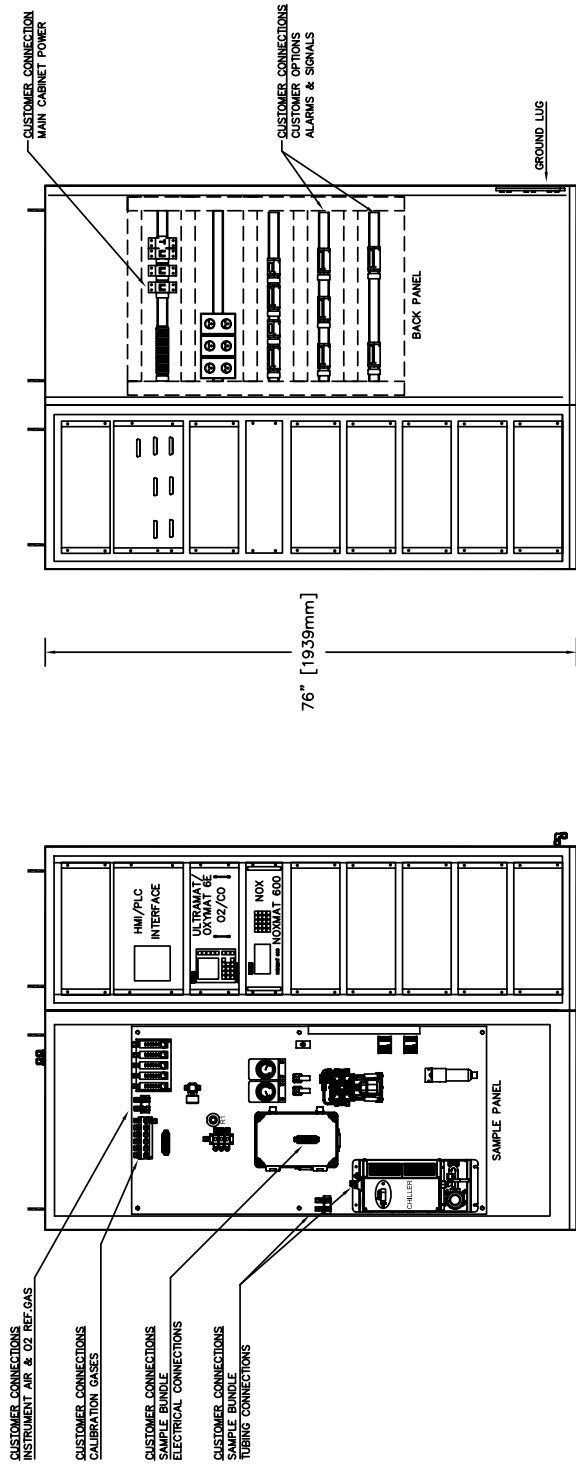
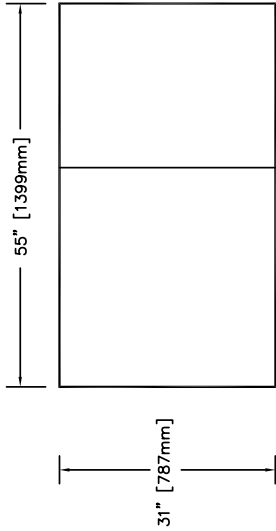

SIEMENS
CEMS CABINET

APPROXIMATE WEIGHT ~500 LBS.

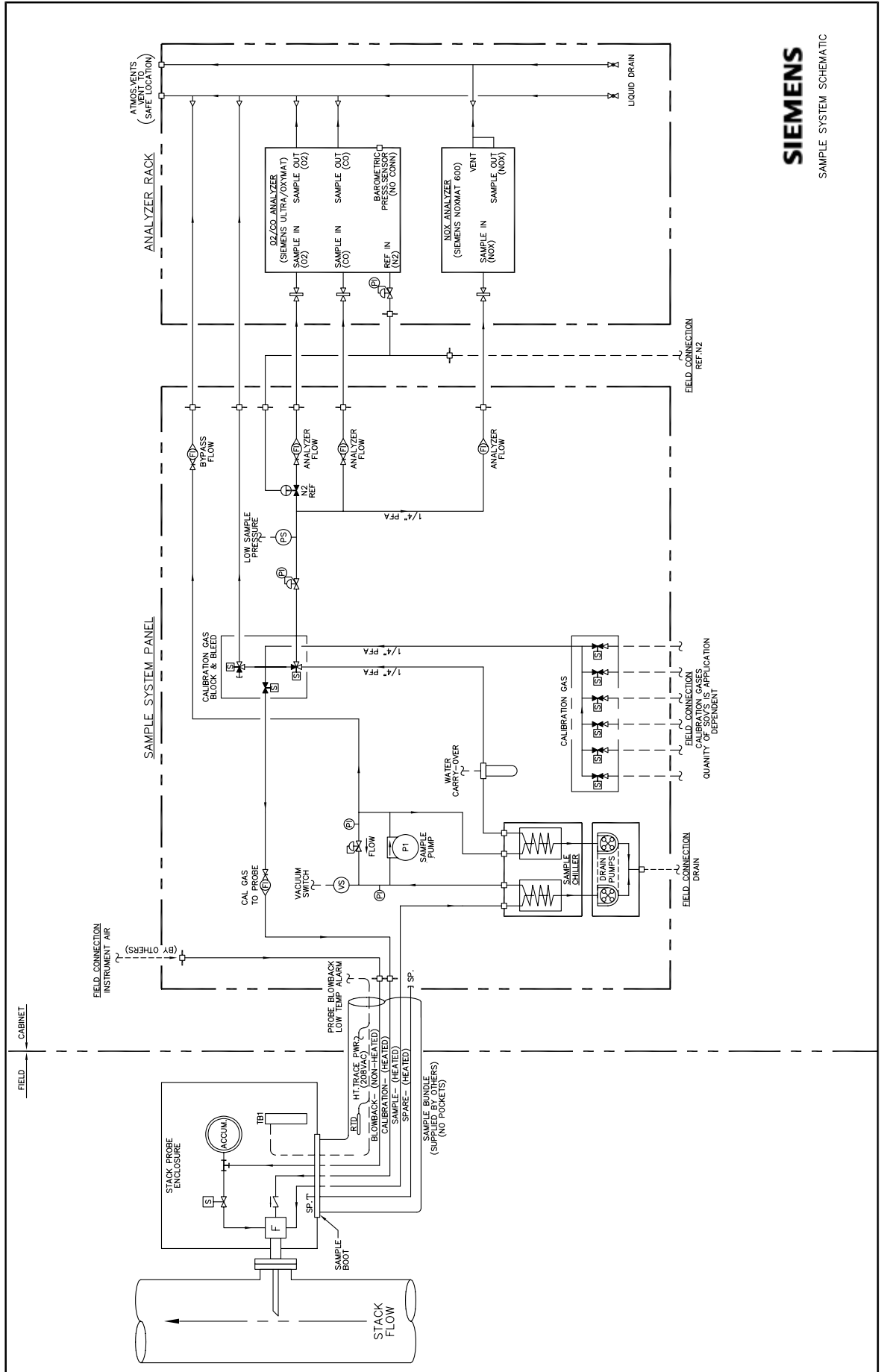

SIEMENS
SAMPLE SYSTEM SCHEMATIC

SIEMENS

SAMPLE PROBE ENCLOSURE

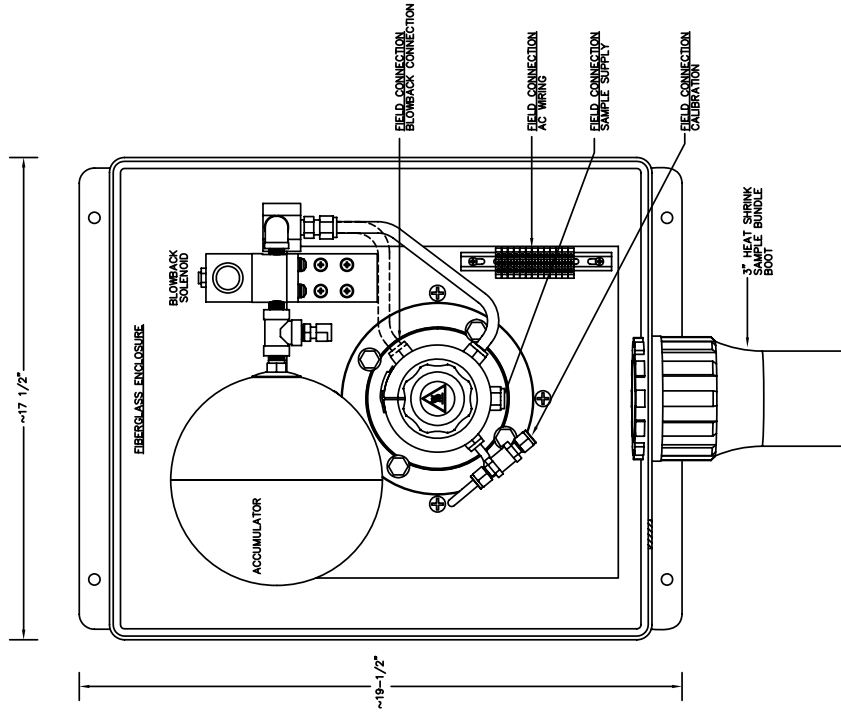

FRONT VIEW (DOOR REMOVED FOR CLARITY)

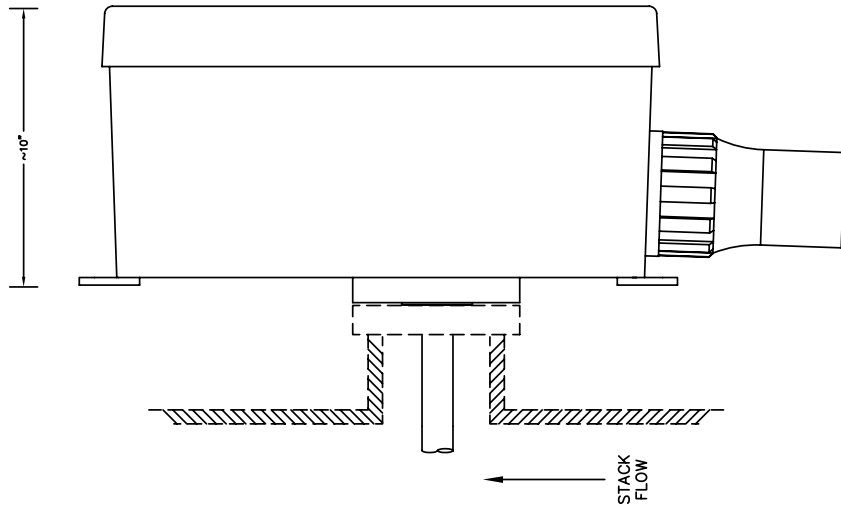

For more information, please contact:

Siemens Industry, Inc.
5980 West Sam Houston Parkway North
Suite 500
Houston, TX 77041
Phone: 713-939-7400
Email: ProcessAnalyticsSales.industry@siemens.com
usa.siemens.com/analyticalproducts

Siemens Flyer
August 2019

Published by
Siemens Industry, Inc.

1-800-964-4114
info.us@siemens.com

Process Automation
Process Industries and Drives
100 Technology Drive
Alpharetta, GA 30005

Subject to change without prior notice
Order No.: PIASS-00004-0415
Printed in USA
All rights reserved
© 2019 Siemens Industry, Inc.

The technical data presented in this document is based on an actual case or on as-designed parameters, and therefore should not be relied upon for any specific application and does not constitute a performance guarantee for any projects. Actual results are dependent on variable conditions. Accordingly, Siemens does not make representations, warranties, or assurances as to the accuracy, currency or completeness of the content contained herein. If requested, we will provide specific technical data or specifications with respect to any customer's particular applications. Our company is constantly involved in engineering and development. For that reason, we reserve the right to modify, at any time, the technology and product specifications contained herein.