

SIEMENS

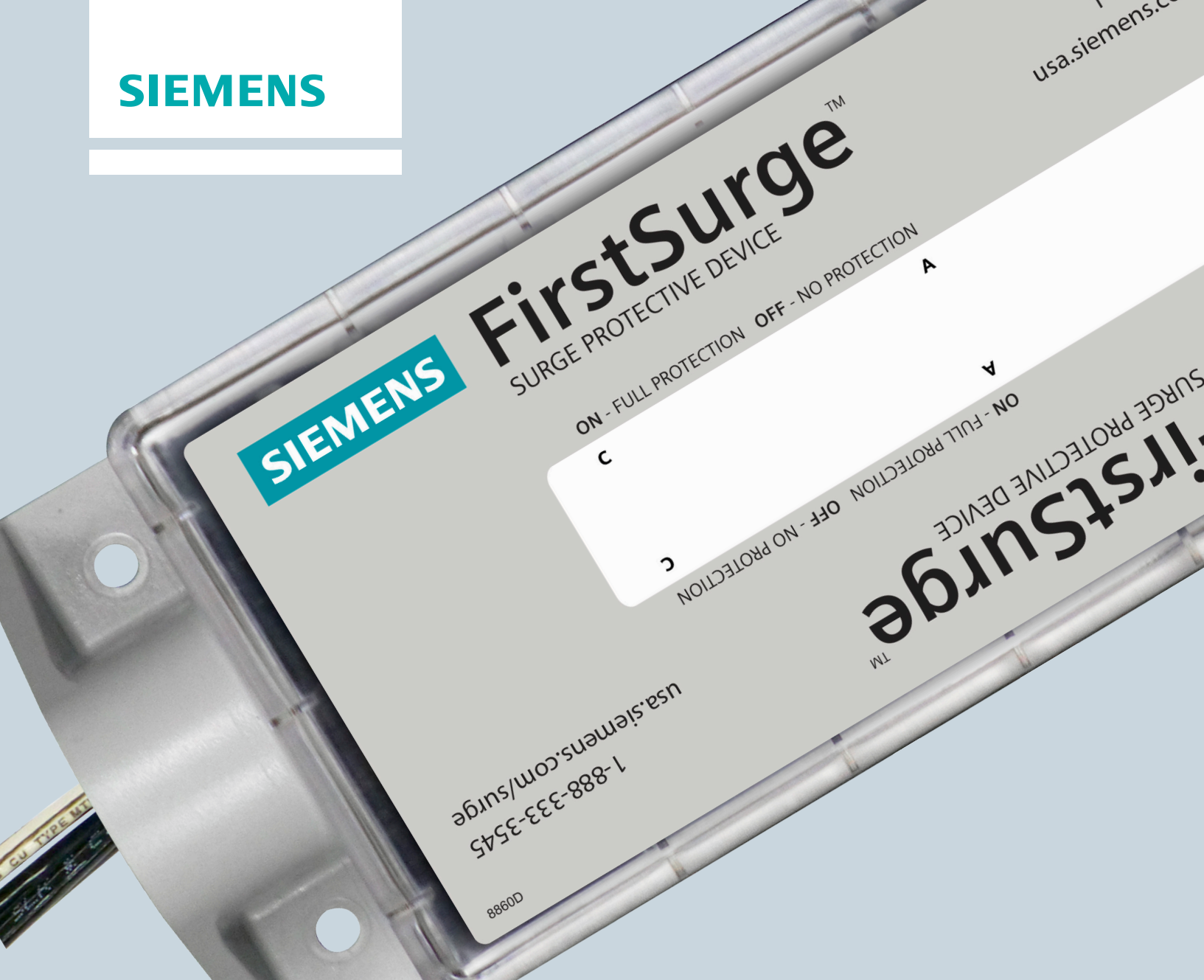

Total Home Surge Protection for Point-of-Entry

FirstSurge™

User Manual - Canada (English)



Introduction

Thank you for choosing the Siemens FirstSurge™ Residential Surge Protective Device.

Save this manual! It includes instructions for obtaining warranty service and for returning a defective device.

Please read and understand all information in this manual prior to installation. The procedures contained herein are not intended to supersede local or national electrical codes. Check all applicable electrical codes to ensure compliance. In all instances, local and national electrical code requirements are to be followed.

This manual provides instructions for installing the FirstSurge™ Surge Protective Device (SPD). The FirstSurge™ SPD can be mounted three ways. The preferred way is to mount the SPD directly to the outside of the electrical panel equipment using the chase nipple on the body of the SPD. It can also be installed against a panel/wall using installer supplied hardware, or it can be installed using an optional Flush Mount Kit. The latter two methods require use of additional conduit and hardware (not provided).

The FirstSurge™ provides protection from damaging transient voltage surges and spikes. Proper installation is imperative to maximize the effectiveness and overall performance of this device. This device must be installed by a licensed electrician. The electrician should follow the steps outlined in this manual to insure proper installation.

Note: Siemens products are extensively tested to industry standards as set by ANSI/IEEE C62.41.1-2002, C62.41.2-2002 and C62.45-2002. FirstSurge™ is listed to the most recent edition of UL 1449. This product is suitable for installation on electrical distribution equipment capable of delivering not more than 100,000 rms symmetrical amperes.

During installation into an electrical system, the FirstSurge™ must NOT be energized until the electrical system is installed, inspected and tested. All conductors must be connected and functional.

Failure to follow the guidelines in this manual can lead to abnormally high voltage being applied to the SPD. This may cause the FirstSurge™ unit to become inoperative. The warranty does not cover an incorrectly installed device.

Do not high potential test the electrical system with the SPD connected. Failure to disconnect the SPD during elevated voltage testing will result in damage to the suppression components and/or other electronic components (see Safety Information).

Parts List and Inspection

Items included in the package consist of the following:

- 1 FirstSurge™ Surge Protective Device
- Data Sheet
- 1 User's Manual (this document)

If the Flush Mount Kit (Part #XMFMKIT) was ordered, additional parts are supplied as follows:

- 1 Flush Mount Plate
- 4 Pan-head Screws

See Figure 3 for installation

Carefully inspect each item in the package for signs of damage. If damage is found, please contact Siemens Technical Support: 1-888-333-3545. For more information about this product or other Siemens products, visit www.siemens.ca/surge.

Safety Information

This section provides pertinent safety information that must be considered before installing the SPD.

- Do not install this device during a lightning storm.
- This device is rated NEMA 4X. Suitable for indoor and outdoor applications. The customer must seal the conduit nipple against the panel using watertight fittings (not supplied) to ensure a watertight connection.
- Do not install the surge protector in an excessively hot or moist location.
- Other safety considerations are listed on the previous page.

Operation

Siemens FirstSurge™ Residential surge suppressor normally requires no remedial action. However in the event of a power anomaly or a malfunction, the operational status may change and may require action. The table below outlines the operating conditions of the FirstSurge™ and any correction action if required.

This device features internal circuitry that will disconnect the surge protective component at the end of its useful life. Power will maintain to the load, however the load is now unprotected. Follow the manufacturer's instructions for replacing the device.

Light 1	Light 2	Alarm Red	Audible Alarm	Corrective Action
Out	Out	Out	Off	Reset Breaker if re-opens Replace Unit
Green	Green			No action
Out	Green	Blinks	Sounds	Replace Unit
Green	Out	Blinks	Sounds	Replace Unit
Green	Green	Blinks	Sounds	Check Neutral to Ground Connection before Replacing Unit

Model	Voltage Rating & Service Type
FirstSurge™	120/240V Single Phase

Specifications	
Temperature Operating	-40°C (-40°F) to +60°C (+140°F)
Temperature Storage	-55°C (-65°F) to +65°C (+149°F)
Audible Noise	None
Service Clearance	36 in (94.1 cm) in front of the unit
Installation Type	Chase Nipple
Wire Length vs. Response Time and Let-Through Voltage	1 ft (31.7 cm) of wire = 1 nanosecond. 175 volts per foot (6kV,3kA, 8/20 microseconds) are added to the clamp voltage.
Wire Size & Installation Torque	Wire Size = #10 AWG, torque to 18 in. lbs.
Circuit Breaker Connection	20 Amp
System Grounding	Per IEEE STD 142-1991. For sensitive electronics/computer systems, the recommended ground impedance is 25 ohms or less.

Figure 1: Typical Panel Installation

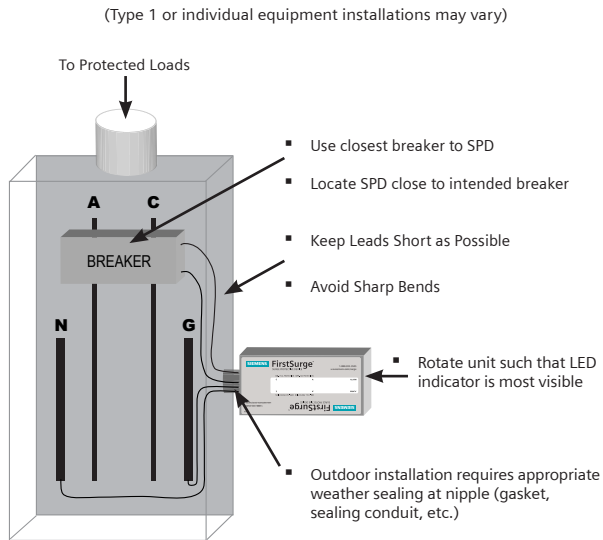
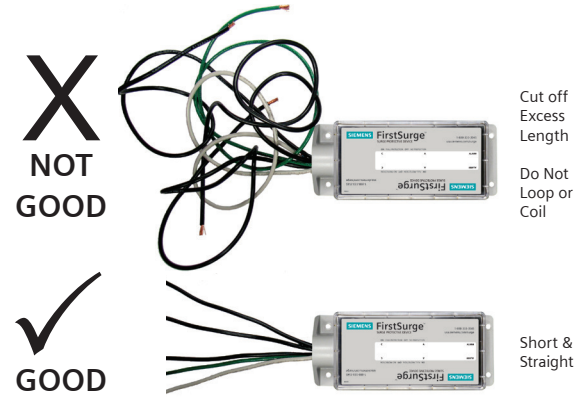

Figure 2: Leads Short & Straight



Installation

FirstSurge™ is a Type 2 SPD. It is suitable for use downstream of the service disconnect.

Pre-Plan your installation. You need to accomplish the following:

- Meet all National and Local codes (NEC® Article 285 and UL 1449 address SPDs).
 - Confirm System voltage to SPD voltage (120V SPD will fail instantly on 240V, 277V, etc.).
 - Mount SPD as close to panel or equipment as possible to keep leads short. (long leads hurt performance).
 - Ensure leads are as short and straight as possible, including neutral and ground. Use a breaker position that is close to the SPD and the panel's neutral and ground.
 - Recommended breaker size is 20A.
 - Make sure system is grounded per NEC® and clear of faults before energizing SPD. (inadvertent system problem may fail SPD).
 - Never Hi-Pot test Any SPD. (will prematurely fail SPD).
- Use voltmeter to check voltages and ensure correct SPD. See Data Sheet for specs and wire-outs.

- Determine Mounting location – weather resistant equipment may be required.
- If SPD has optional Flush Mount Kit, pre-plan its installation. See Figure 3. (If flush mounting, be careful to not drop SPD into wall).
- Remove power from panel/source. Confirm panel/source is deenergized.
- Identify breaker location and SPD location. Position SPD such that LEDs are best visible. If Flush Mount Kit was ordered, follow Flush Mount instructions and then proceed at #6.
- Mount SPD – weather resistant applications require additional sealing, etc. (not included)
 - Remove an appropriately sized knockout from panel.
 - Connect conductors as appropriate – short and straight as possible.
- Label or mark conductors as appropriate (neutral: white, ground: green, energized: black).
- Make sure system is bonded per NEC® and is clear of hazards or faults before energizing (N-G bonding not per NEC® will fail SPDs: #1 cause of SPD failures).
- Energize and confirm proper operation of green LED indicators. If any connected phase LED does not illuminate, remove power, check all connections and test again. If any connected phase LED still does not illuminate, contact Siemens Technical Support at: 1-888-333-3545.
- The SPD is equipped with an audible alarm which will sound in the event of an alarm condition. This indicates a problem with the SPD which requires further evaluation. There is no test or silence switch. De-energizing the SPD will silence the alarm.

CAUTION

VERIFY THAT ALL POWER CIRCUITS ARE DEENERGIZED BEFORE MAKING CONNECTIONS
All electrical connections should be performed by a qualified (licensed) electrician or technician. All wiring must comply with the National Electrical Code (NEC®) and applicable local codes.

Flush Mount Installation Instructions

1. Select the location where the SPD and Flush Mount Kit (XMFMKIT) will be mounted. Aesthetics may have to be sacrificed in order to achieve maximum surge protection.
2. Place the Flush Mount Kit plate where it will be mounted and trace the center hole and mounting holes. Cut this shape into the mounting surface and mount the XMFMKIT panel to the mounting surface
3. BE CAREFUL TO NOT DROP THE SPD INTO THE WALL.
4. Install the SPD to the back side of the Flush Mount Kit plate using the four 8/32 x 5/8" Thread Cutting Screws provided with the XMFMKIT kit.
5. Proceed with #6 on page 3.

Figure 3: Typical FirstSurge™ SPD installation

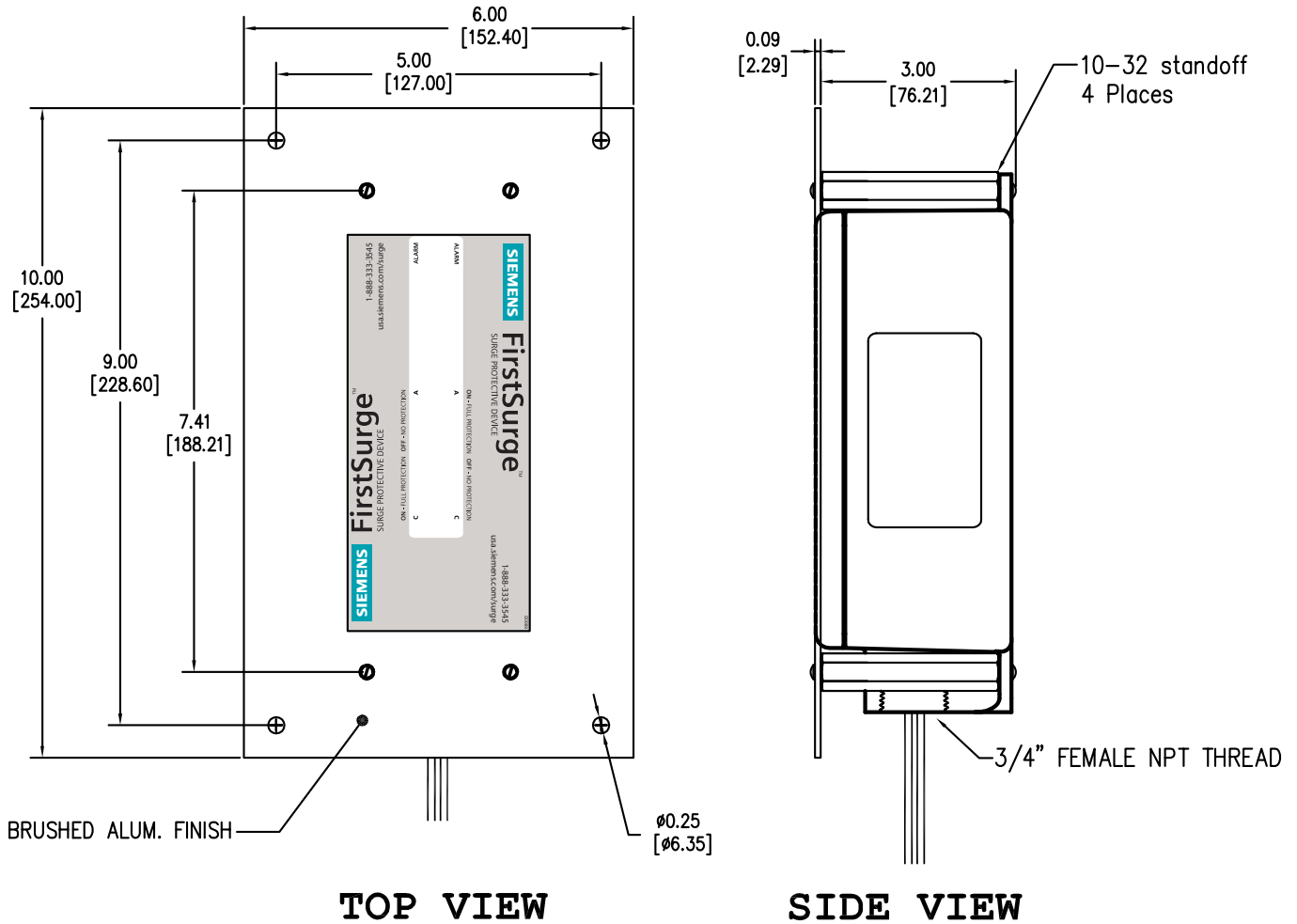

NOTICE

CONDUCTING DIELECTRIC AND/OR HIGH POTENTIAL TESTING WILL CAUSE INTERNAL DAMAGE TO THE SPD UNIT. DO NOT PERFORM DIELECTRIC OR HIGH POTENTIAL TESTS WITH THE PHASE OR NEUTRAL SPD WIRES CONNECTED.

Figure 4: Dimensions & Weight

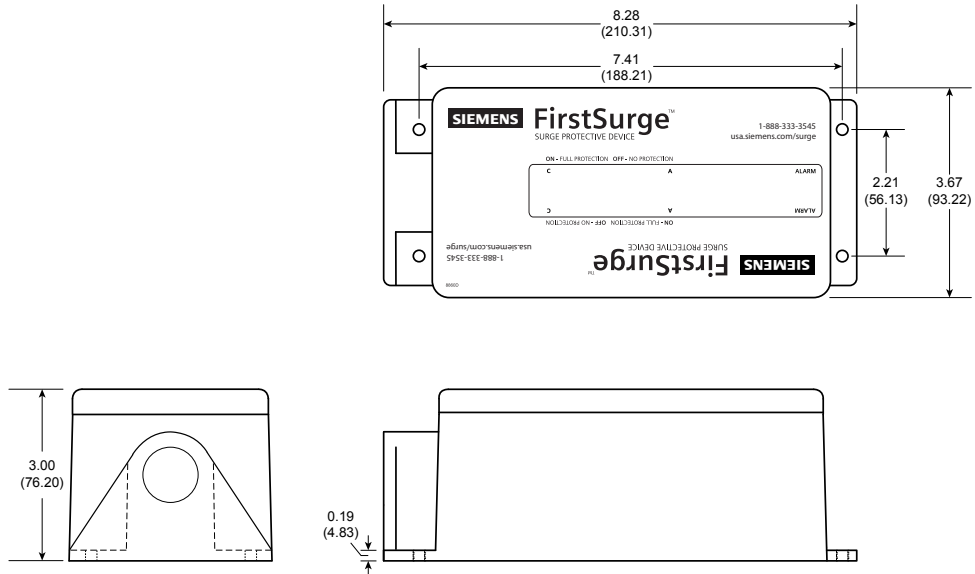

Troubleshooting & Service

Please contact us for any service related issues. We want to take care of any problems.

Quality SPDs withstand severe duty and attempt to protect their load until failure. There are electrical anomalies that SPDs cannot protect against. These are generally Sustained Overvoltages also known as Temporary Overvoltages (TOVs). In this context, Sustained Overvoltages may be only a few cycles. Failed SPDs tend to be symptoms, not root causes. As a generalization, the single largest 'killer' of SPDs is reference to ground issues. If the SPD shows problems on startup, there is reasonable chance of bonding/grounding/misapplication issue. This permanently damages the unit. If not corrected, it will happen again.

Any returns need a Return Authorization (RA) number.

Warranty & Service

LIMITED WARRANTY

Siemens warrants its AC electrical distribution equipment protection products against defective workmanship and materials for 10 years. Liability is limited to the replacement of the defective product. A Return Material Authorization number (RMA #) must be given by the company prior to the return of any product. Returned products must be sent to the factory with the transportation charges prepaid.

The company specifically disclaims all other warranties, expressed or implied. Additionally, the company will not be responsible for incidental or consequential damages resulting from any defect in any product or component thereof.

Siemens Technical Support & Customer Service

1-888-333-3545
 info@purgethesurge.com

This manual as well as information about the entire Siemens product line are available on the Internet at: www.siemens.ca/surge.

Prior to calling Siemens for technical support, please have the following information available:

Model Number of unit: _____
 Manufacture Date: _____
 Purchase Date: _____
 Your Order Number: _____

Return Shipment Address:

Siemens
 14550 58th Street North
 Clearwater, FL 33760

Attn: RMA# _____

Siemens Canada Limited
1577 North Service Road East
Oakville, ON L6H 0H6
Canada
888-333-3545
info@purgethesurge.com

European Authorized Representative
Obelis s.a.
Boulevard Général Wahis 53
1030 Brussels, BELGIUM
Tel: +(32) 2. 732.59.54
Fax: +(32) 2. 732.60.03
E-Mail: mail@obelis.net



Order No. EM-LP-1414 | Printed in USA |
© 2015, Siemens Industry, Inc.