

Modern plant control centers and operator control concepts

SIEMENS

HMI+ supports operative process control of industrial production processes by means of user-centric process visualization

Dipl.-Ing. S. Kempf, Siemens AG, Karlsruhe
Dipl.-Ing. L. Glathe, Siemens AG, Frankfurt

February 10, 2012

Summary

This article presents a user-centric concept for structuring industrial process control. The background to this concept is the constantly increasing complexity of the processes to be monitored and the working environment in control rooms from the perspective of the operators. The use of modern plant control centers and operator control concepts can support and offload operators in the execution of their tasks by means of a powerful human machine interface.

Content

HMI+ supports operative process control of industrial production processes by means of user-centric process visualization	3
1. Introduction	3
2. Concept of user-centric process visualization	3
3. Display and operator control concept using the example of a batch column	6
4. Conclusion.....	8
Bibliography.....	9

HMI+ supports operative process control of industrial production processes by means of user-centric process visualization

1. Introduction

The primary task of the operator is to carry out operative process control on the basis of process and plant information from the production process and its logistics and auxiliary processes [1].

Operative process control aims to maintain the safe operation of the production plant in accordance with requirements, to maximize the availability of the production system despite isolated faults, and to guarantee product quality despite fluctuations in raw material quality, faults in the plant, and variations in throughput [5].

Finally, the process sequence must be optimized with regard to costs, quality and safety.

The operator's primary tasks are extended in particular by high cost pressure, for example through material planning tasks, broader quality assurance and efficient operation of the plant.

These extended tasks are traditionally contained in the area of the plant control level.

The required information is presented to the operator in centralized control structures, mainly via the display and operator control components of the process control system in the control room. Furthermore, additional information from a heterogeneous system world, e.g. PIMS, ERP, LIMS etc., must be supplied to the operator and presented in relation to the task. This heterogeneous automation landscape increases the complexity of the working environment of control room operators.

In addition, the rising level of automation of today's industrial production processes results in a reduction in the number of control room personnel and, in parallel, in a sharp increase in the volume of process information to be monitored by each operator, caused, for example, by combining control rooms.

This increasing complexity in production processes, as well as the working environment in control rooms, makes it difficult for operators to

form a holistic mental picture of the plant and processes to be monitored. But precisely this mental picture is hugely important for monitoring the status of the plant/process.

The use of user-oriented and task-oriented concepts offers a solution to this problem. These are aimed at creating integrated work systems, i.e. combined optimization of the application of technology, organization, and qualification of the user. Instead of adapting people to technology, technology must be adapted to people [2].

Starting from the planning phase of process plants, these aspects of user-centric process visualization must be sufficiently taken into account in the design and conceptual definition of plant control centers and operator control concepts.

This user-centric human machine interface (HMI), referred to below as HMI+, has a crucial share in this. In the remainder of this article, special attention is given to the design of operator consoles and their elements and structures.

2. Concept of user-centric process visualization

The display and operator control concept for plant operators has changed significantly in recent years. Where previously mosaic panels were used for operator control, today the operator sits at a PC workstation with, for example, 4 screens. Until now, the benefits of the mosaic panel and recorder, such as clear representation of process states, were rarely adopted for PC workstations. Rather, the focus was on eye-catching graphics which were, however, of no great benefit in performing the actual operator task.

Visualization systems and processes used today achieve positive results only in some areas; for example, individual plant sections or sub-processes can be clearly represented using graphics displays.

The systems are characterized by:

- A mishmash of different devices and software products with non-homogenous operator interfaces
- Multiple input and output devices per PC at the operator workstation
- Standard configuration of operator workstations (e.g. always 4 screens per client)
- Cost-driven workstation design

However, the processes used to represent process values display weak points with regard to the following

- Display of the overall status of the process - the big picture
- Operators receive information predominantly through the use of alphanumeric displays instead of analog representations with pattern recognition
- Attraction of the operator's attention by means of shape-coding and color-coding
- Task-related and activity-related visualization
- Display of information

The concept and design phases are also accompanied by conceptual weaknesses:

- Process pictures are created on the basis of isolated piping and instrumentation diagrams with a different display purpose
- Particularly in new plants, it is not possible to involve the operating personnel in the design process at an early stage
- Lack of a process visualization standard encompassing all devices
- Lack of process know-how in the design process

HMI+, a user-centric concept for designing industrial process control, is described below (see Fig 1).

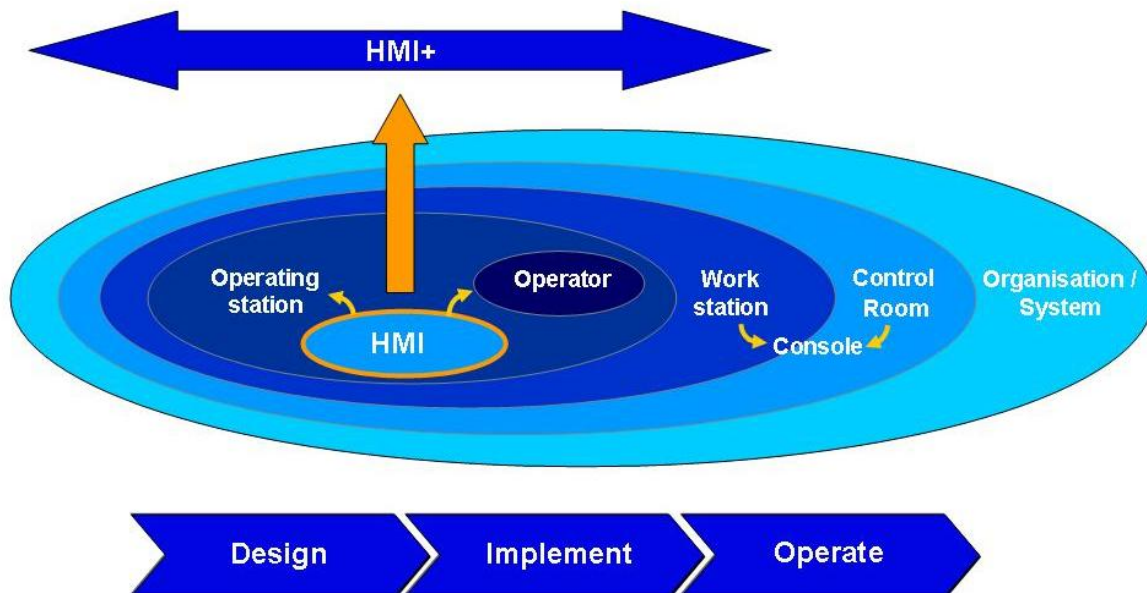

Fig. 1: HMI+, user-centric concept for designing industrial process control in accordance with [3]

This concept combines thoroughly familiar elements and structures of operator control units, such as operator interfaces and their procedures, with the design of operator consoles and control rooms, and organizational measures to form a holistic solution approach.

The starting point for all considerations is the detailed analysis of operator tasks with regard to process control and additional tasks in the control room area (see the examples in Table 1). This analysis must be carried out specifically for each plant on a project-related basis and with the involvement of the team of operators.

No.	Task	Tätigkeit	Activity	Requirements for process visualization
1	Process control	Monitoring an automated plant	Monitoring essential operating parameters (process-related KPIs)	<p>Overview displays with essential operating parameters of the plant to be monitored</p> <p>Display of the permissible tolerances</p> <p>Display of limit violations</p> <p>Display of alarms and their priorities</p> <p>Analog displays for "pattern support"</p> <p>Trend displays for assessing situations and deciding on operating strategy</p>
2	Process control	Monitoring an automated plant	Detecting/perceiving faults	<p>Attracting attention by means of color scheme with distinct alarm colors</p> <p>Avoidance of cognitive overload</p>
3	Process control	Monitoring an automated plant	Finding/identifying the cause of the fault	Jump function from alarm page to the measuring point in the process picture
4	Materials planning	Planning materials	Entering recipe parameters	<p>Uniform and device-neutral presentation of the operator screen forms</p> <p>Use of the same input and output devices as for process control</p>
5	Documentation for process control	Keeping a shift logbook	Entering the relevant process value in the shift logbook	Presentation of all relevant process values (in a log)
6	Extended quality assurance	Monitoring of quality-related process parameters	Monitoring of quality KPIs	<p>Visualization of quality KPIs in overview displays of the process control system</p> <p>Device-independent, homogeneous presentation of the quality KPIs</p>

Table 1: Requirements for process visualization resulting from operator tasks

In addition to project-specific issues, the following generally valid issues for improving process visualization have been derived from the prioritization of the requirements for process visualization (cf. Table 1):

Procedure for representing process values:

- Additional use of abstract operator procedures in which the process topology plays a subordinate role. For example: process-related overviews with essential operating parameters of the plant to be monitored in an arrangement of hybrid displays with tolerance and limit value visualization that supports pattern recognition. The operating parameters to be displayed are selected in interaction with the operating personnel according to certain criteria. Around 80% of operator input and monitoring during normal operation of the plant takes place from these overviews.
- Partial replacement of alphanumeric displays with analog displays, hybrid displays (analog and status display), and trend representations.
- Reduction in the complexity of the process flow diagrams thanks to task-oriented and process-status-oriented selection of the process values to be represented (dedicated representations for start-up and shutdown, normal operation, load change, and diagnostics)
- Use of a color scheme including alarm colors
- Process picture representations as a component in organizing the operator console
- Representation of information instead of data, e.g. innovative representational objects for temperature distributions, or trend curves for assessing situations and deciding on operating strategies

System solutions:

- Multifunctional integrated operator workstation with homogenous operator interface, operator control with the same input/output devices
- Applications of all individual devices in accordance with a device-wide style guide for process visualization
- Configuration of the operator workstation as part of the organization of the operator console
- Ergonomic design of the operator workstation
- Design of the control room as the living space for the operators

Measures in the concept and design phase:

- Specify the process visualization concept in the style guide of the process visualization system
- Integrate the users (operating personnel) into the design process at an early stage. If this is not possible, the abstract representations must be created later in the optimization phase
- Involve experts with process know-how

The concept is based on the rules and recommendations for the structure of displays where screen systems are used for process control listed in VDI/VDE 3699 "Process control using display screens" [4].

The recommendations in that document are continued in this concept and placed in the context of user-centric process visualization.

3. Display and operator control concept using the example of a batch column

The concept described in the previous section is explained below using the example of a distillation column.

The tasks of the operator of a distillation column are:

- Starting up and shutting down the distillation column
- Monitoring the process-related characteristic variables, e.g. differential pressure
- Responding to changes in pressure (fraction change) at the head of the column
- Responding to alarms

These tasks are taken into account in the display and operator control concept to guarantee an optimal working environment for the operator.

An overview display is selected for monitoring the process-related characteristic values. This contains the important process values and closed-loop controls of the column. This display has the advantage that large volumes of data can be combined for the condensed presentation of information.

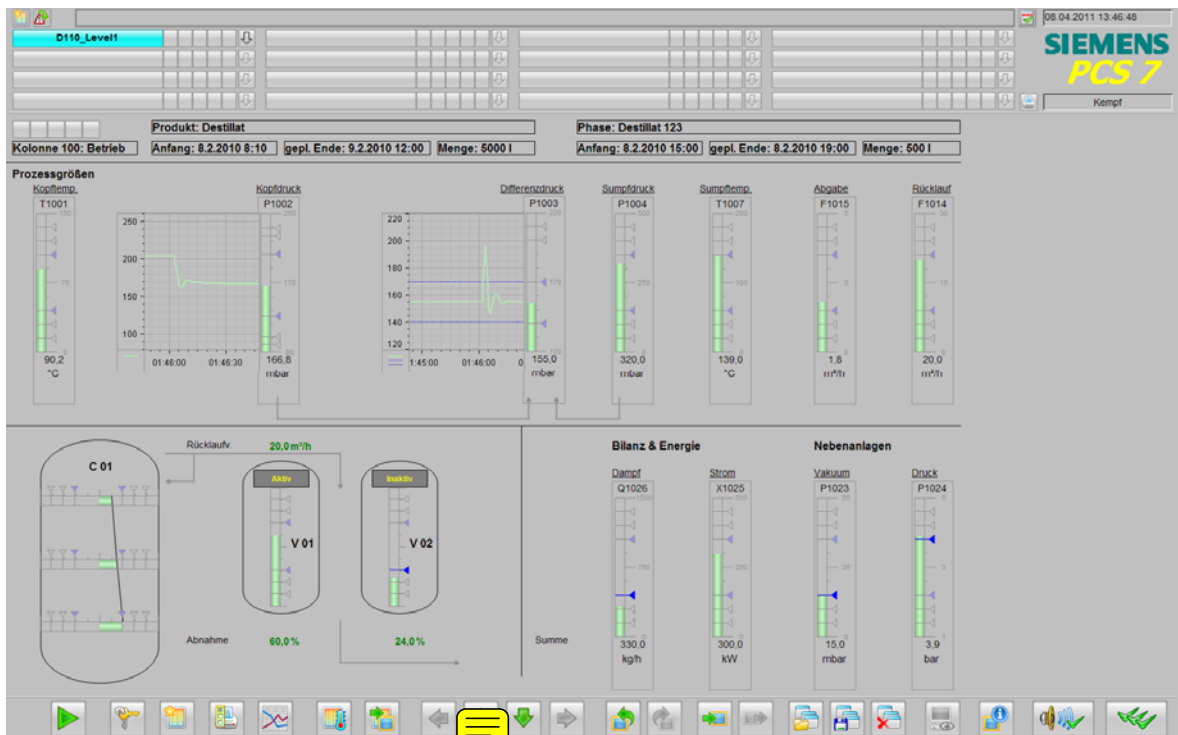

Fig. 2: Overview diagram of the column **BILD DEUTSCH**

The task "monitoring the head pressure" is effectively supported by a trend display on the operator screen. At a constant head temperature (T1001), the head pressure (P1002) drops significantly when changing from one fraction to the next. The operator must respond to this by changing the draw-off tank.

The task "monitoring the differential pressure", especially following a fraction change, is supported by a trend display showing the permissible tolerance band. The differential pressure (P1003) is a measure of the gas load in the column and must be kept approximately constant. This is why the optimal working range is represented in the trend display.

Other important characteristic variables represented include the energy consumption of the plant and the reflux ratio.

New hybrid displays enable the evaluation of the process values. These visualize the acceptable range for the process value. Otherwise, evaluation using an analog value would be possible only with experience.

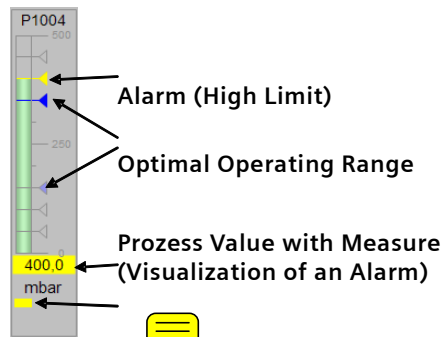

Fig. 3: **Neue Hybridanzeige**

Another example of evaluating process variables is the representation of the temperatures in the column.

Evaluating the process status using the temperatures as analog values can only be done with expert knowledge (cf. Fig. 4; are the temperatures within the optimal working range?).

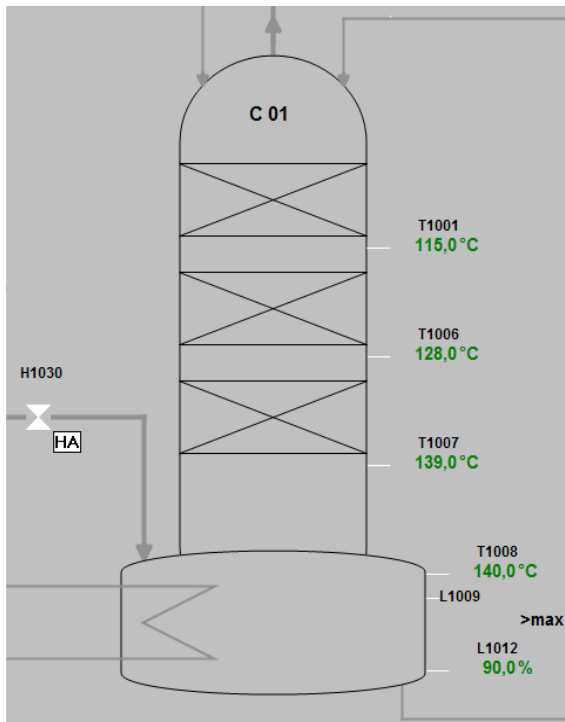

Fig. 4: Typical view of a distillation column

If the temperatures are instead visualized as a temperature curve showing the optimal working range, the evaluation can be done via the picture. (cf. Fig. 5; one temperature is not in the optimal working range).

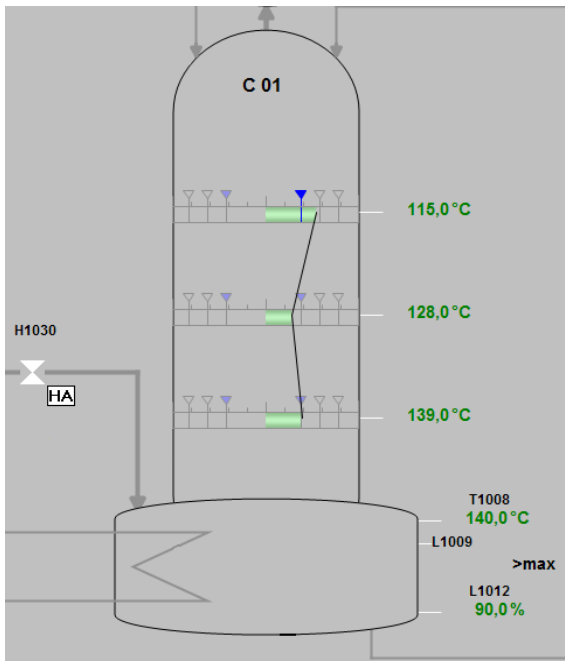

Fig. 5: View of a distillation column with vertical temperature curve

4. Conclusion

The suggested user-centric visualization concept is intended as a holistic solution approach for effectively coping with the increasing complexity of the processes to be monitored and the working environment in control rooms from the operator's perspective.

Many aspects justify investment in modern human machine interfaces or call for redesigning of traditional operator control concepts: safe operation of production plants through avoidance of operator errors, extension of operator tasks, loss of operating know-how through fluctuations in employee numbers, and, not least, increased work load resulting from the merging of control rooms. Initial experiences in application argue in favor of the use of these concepts.

Bibliography

- [1] NA 120 "Operator Workplace from the Human-Process Communication Point of View"
- [2] Wickens, C.D., Holland, J.G. (2000). Engineering psychology and human performance. New Jersey: Prentice Hall.
- [3] EEMUA 201 „PROCESS PLANT CONTROL DESK UTILISING HUMAN-COMPUTER INTERFACES - A Guide to Design, Operational and Human-Computer Interface Issues“
- [4] VDI/VDE 3699 "Process control using display screens"
- [5] Charwat, H.J. Lexikon der Mensch-Maschine Kommunikation (Lexicon of human machine communication)

www.siemens.com

All rights reserved. All trademarks used are owned by Siemens or their respective owners.

© Siemens AG 2012

Siemens AG

Siemensallee 84
76157 Karlsruhe