



SIEMENS

Ingenuity for life

Scan the
QR code with
the QR code
reader in
your mobile!



STC - GC Siemens Turbo Compressor - Standardized Integrally Geared, Compact Design

The Cost-effective and reliable solution focused
with highest energy efficiency

[siemens.com/global/en/products/energy/compression](https://www.siemens.com/global/en/products/energy/compression)

Since its inception 70 years ago (in 1948), Siemens Integrally Geared Centrifugal Turbo Compressors have been meeting demands for Compression solutions with highest unmatched efficiencies with ensuring highest reliability and best in class quality standards.

Design Concept

- STC – GC Compressors are designed according to customer specifications and process data requirement and in full compliance with API 672 as well as API 617 standards.
- STC – GC Compressors design combines highest efficiency, reliability and compact packaged design with the shortest delivery period & focus on lower investment cost.
- Several different frame sizes have been designed to cover a wide operating range (10,000 – 120,000 m³/hr of volumetric flow).
- Standardized and Pre-designed concept results in a very cost -effective integrally geared centrifugal compressors.
- STC – GC Compressors are designed as a compact single – lift unit, thereby achieving considerable less installation time at site; For an example; GC 10-50 Compressors are designed with a common base frame for drive motor and compressor.
- Compressor Control by Inlet Guide Vane at the first stage results in a wide operating range.

Highlights

- The perfect combination of highest efficiency, cost - competitiveness & optimum Delivery period.
- Powerful, robust, compact, packaged and reliable design.
- 70+ years of experience

Fields of application.

- Air Separation
- Plant Air
- Process Air
- Process Nitrogen

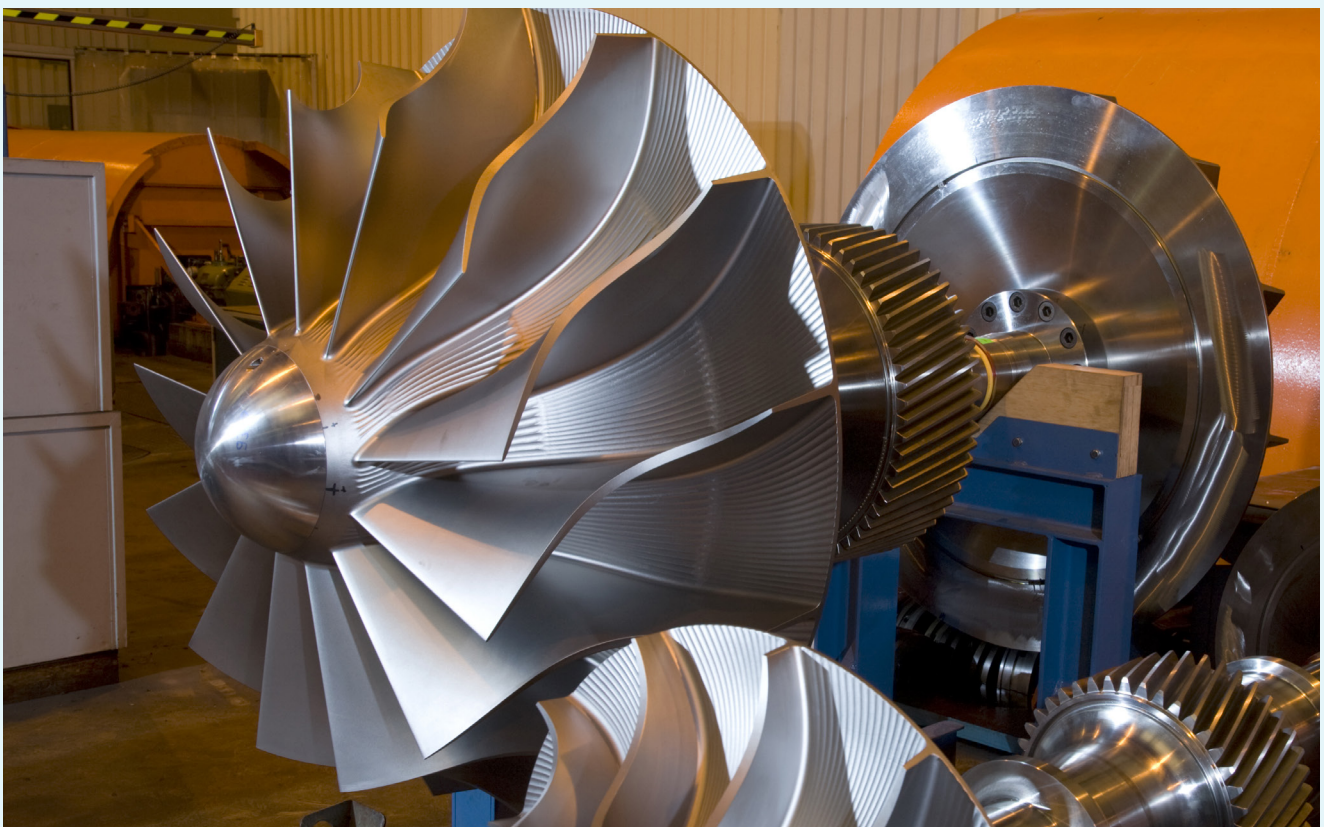

Powerful, Robust and Reliable

- The STC-GC integrally geared centrifugal compressors feature a multi-shaft arrangement with different speeds. All shafts are mounted in maintenance - free, pressure- lubricated sleeve bearings.
- With up to four compressor stages around a central bull gear, the STC-GC compressor series forms a compact unit for the multi-stage compression of air and nitrogen.
- Pre-designed gears, highest efficiency impellers, tailored aerodynamics and pre-defined auxiliaries lead to maximum performance.
- More than 210 units of STC – GC Compressors and 2000 units of STC – GV Compressors are in operation at customers' premises around the globe ensuring customer delight & smoother plant operation.

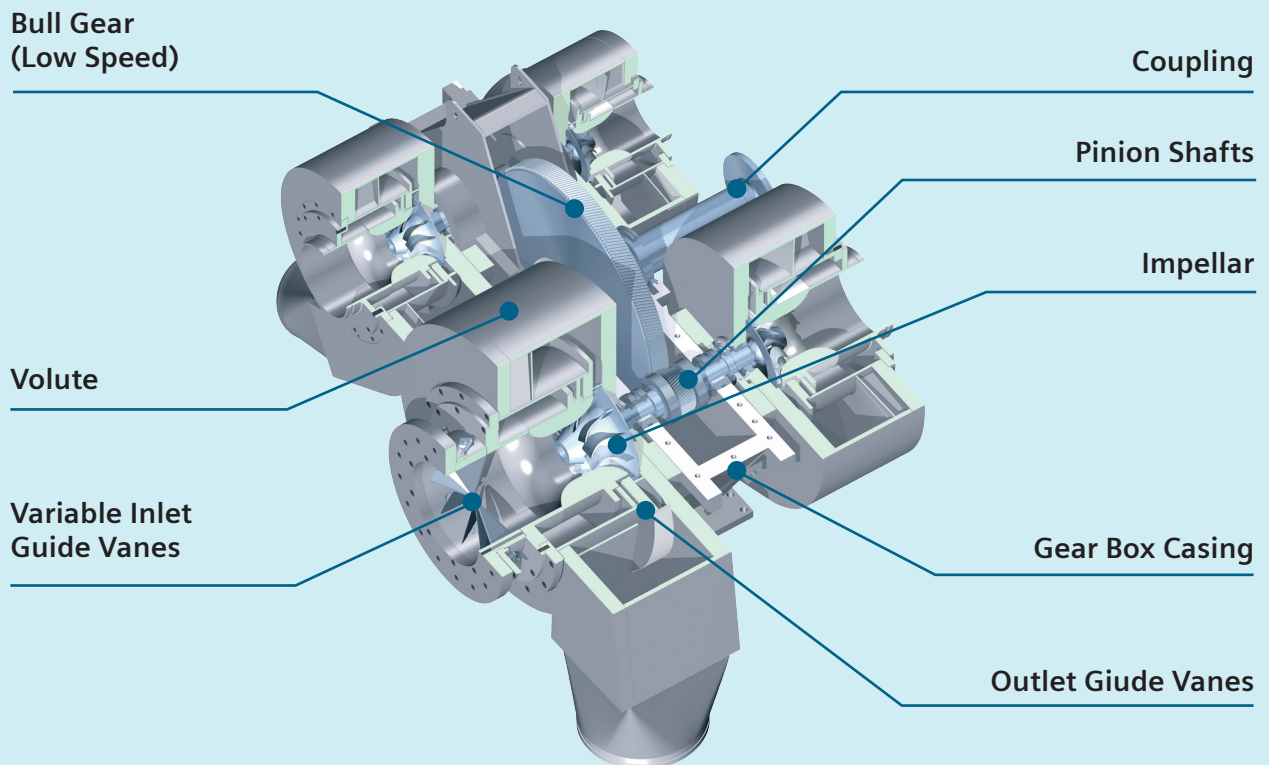

STC GC

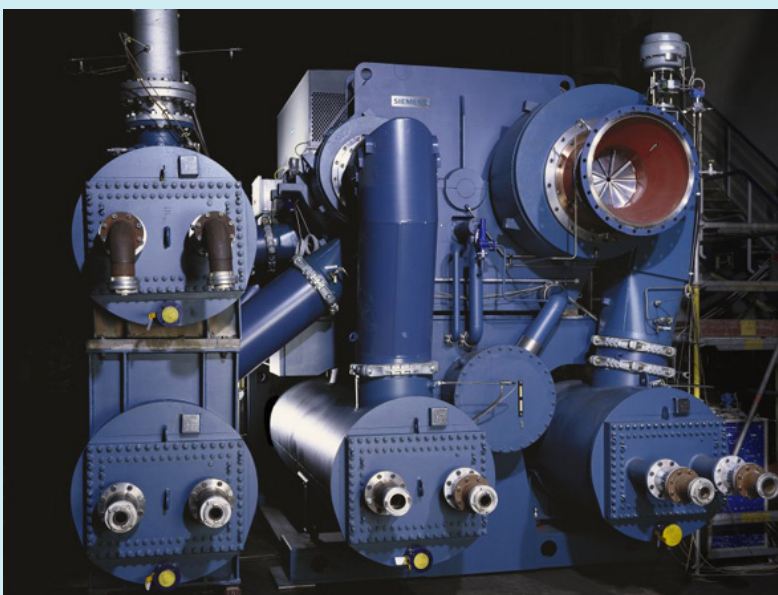

10 - 50 Frames



63 - 100 Frames

Technical Data and Application Range :

Technical Data

STC-GC

- Volume flow rates from 10,000 to 120,000 m³/h (5,900 to 70,600 cfm)
- Suction pressure up to 1.1 bar (16 psi)
- Pressure ratio up to 22 (machine size 10–50)
- Pressure ratio up to 7.5 (machine size 63–100)
- Electric motor drive (fix speed)
- Air and nitrogen

Benefits

- Compact design
- Standardized, pre-engineered for economy and reliability
- Siemens-owned gear technology
- Highest technical quality standards
- Optimized performance
- Shortest lead times
- Reduced investment costs
- Minimal on-site installation

Application Range STC – GC

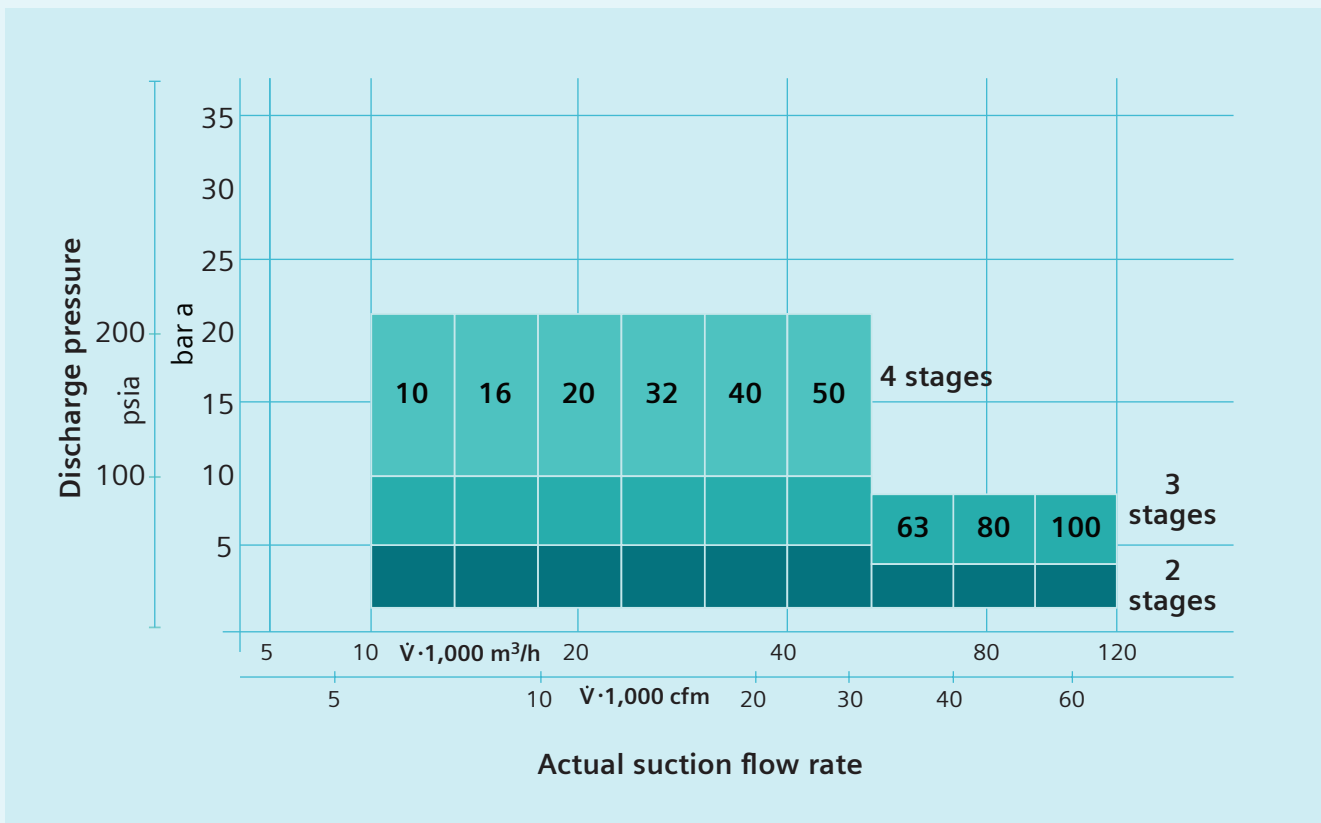

Smart Protection

Compact protection device for standardized integrally geared turbocompressors (STC - GC 10-100)

To ensure optimum operation and protection of the standardized STC-GC, Siemens has adapted and Incorporated the existing compressor automation concept SCAUT.

SCAUT CPD (Siemens Compressor AUTomation Compact Protection Device) is a most suitable and cost saving safety device for operation of Siemens pre-designed STC-GC compressor series which allows optionally the control of the compressor process.

SCAUT CPD is a module derived from the well proven SCAUT product series based on Simatic S7 hardware.

It enables customers to control the entire compression train and ensures a reliable and save operation through a standardized solution with a modular structure.

Benefits

- Highly efficient protection of compressor against incorrect operation
- Monitoring possible in customer DCS, additional anti-surge safety device not necessary
- Suitable for any DCS configuration
- Reliable IGV control for wide operation range with highest efficiency also for part- and peak load to minimize the operational costs
- Process control function optionally included without additional dedicated controller leads to reduced overall CAPEX

STC GC

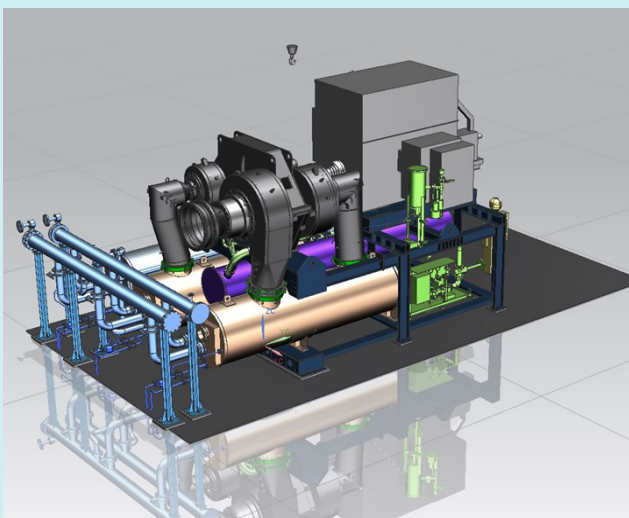

10 - 50 Layout

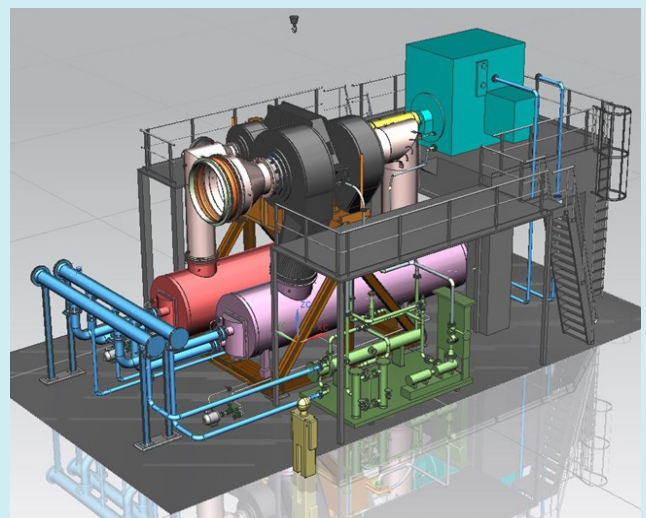

63 - 100 Layout

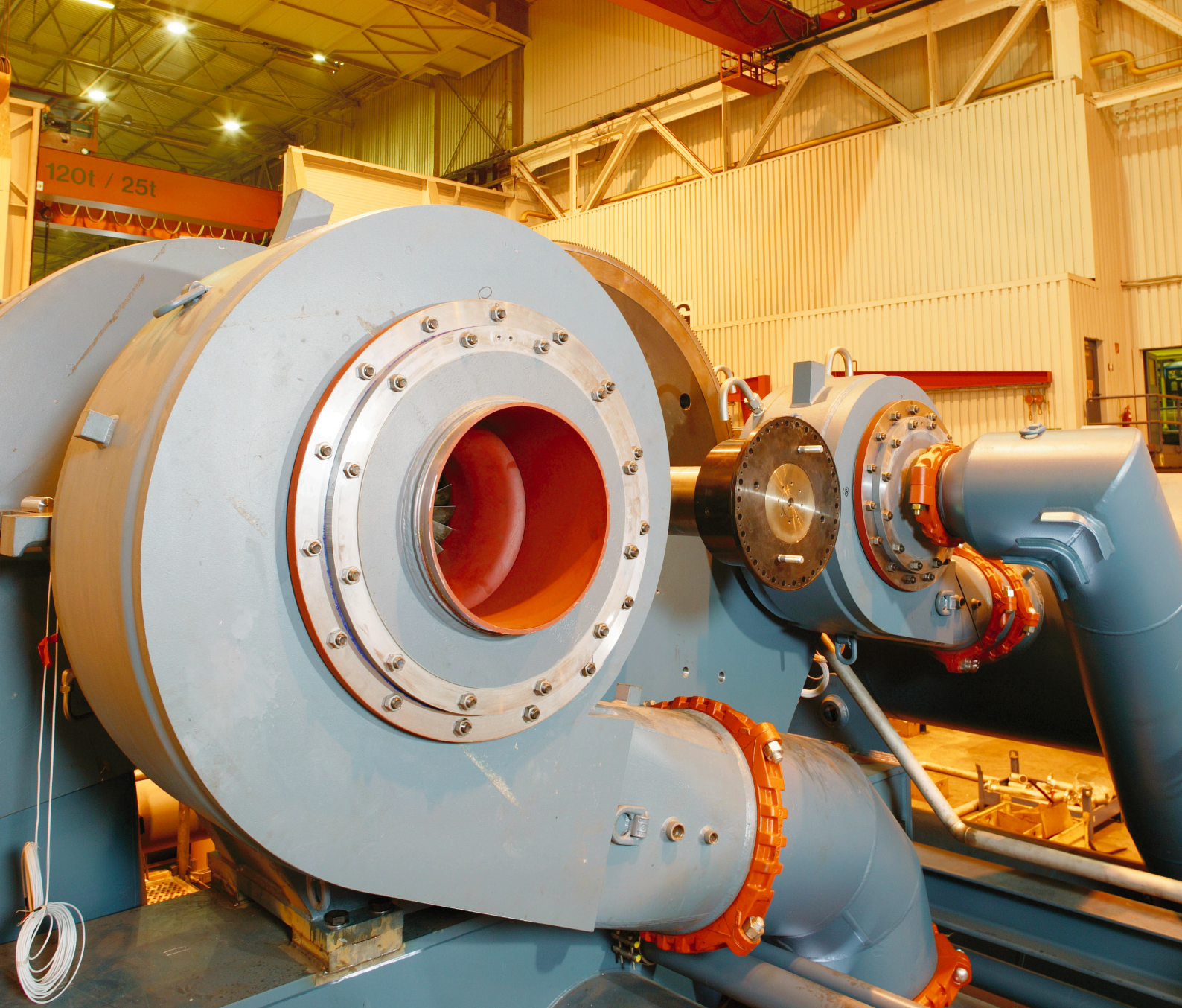

GP O&G ASU & Process Gas

Siemens Ltd.

Birla Aurora, Level 22,
Plot No. 1080, Dr. Annie Besant Road,
Worli, Mumbai – 400030, India

<https://new.siemens.com/in/en/products/energy/compression/integrally-gear-centrifugal-compressors.html>

Siemens AG / ASU & Process Gas

Wolfgang-Reuter-Platz 4
47053 Duisburg, Germany

Siemens Energy Inc.

10730 Telge Road
Huston, Texas 77095, USA

Dresser-Rand India Private Limited

A Siemens Business 187, GIDC, Naroda
Ahmedabad – 382330

**For more information,
please contact our customer support center.**

Phone: +49 180 524 70 00

Fax: +49 180 524 24 71

(Charges depending on provider)

Email: support.energy@siemens.com

All rights reserved.

Trademarks mentioned in this document are the property of Siemens AG, its affiliates or their respective owners.

Subject to change without prior notice. The information in this document contains general descriptions of the technical options available, which may not apply in all cases. The required technical options should therefore be specified in the contract.