

SIEMENS

Grade Crossing Predictor 4000 Field Manual

**Document Number: SIG-00-12-68, Version: A.8
June 2013, Revised September 2018, December 2020,
April 2021, & February 2022**

PROPRIETARY INFORMATION

The material contained herein constitutes proprietary and confidential information, and is the intellectual property of Siemens Mobility, Inc. protected under United States patent, copyright and/or other laws and international treaty provisions. This information and the software it describes are for authorized use only, and may not be: (i) modified, translated, reverse engineered, decompiled, disassembled or used to create derivative works; (ii) copied or reproduced for any reason other than specific application needs; or (iii) rented, leased, lent, sublicensed, distributed, remarketed, or in any way transferred; without the prior written authorization of Siemens Mobility, Inc. This proprietary notice and any other associated labels may not be removed.

TRANSLATIONS

The manuals and product information of Siemens Mobility, Inc. are intended to be produced and read in English. Any translation of the manuals and product information are unofficial and can be imprecise and inaccurate in whole or in part. Siemens Mobility, Inc. does not warrant the accuracy, reliability, or timeliness of any information contained in any translation of manual or product information from its original official released version in English and shall not be liable for any losses caused by such reliance on the accuracy, reliability, or timeliness of such information. Any person or entity who relies on translated information does so at his or her own risk.

WARRANTY INFORMATION

Siemens Mobility, Inc. warranty policy is as stated in the current Terms and Conditions of Sale document. Warranty adjustments will not be allowed for products or components which have been subjected to abuse, alteration, improper handling or installation, or which have not been operated in accordance with Seller's instructions. Alteration or removal of any serial number or identification mark voids the warranty.

See Back Cover for contact information

Copyright © 2022 Siemens Mobility, Inc.
All rights reserved.

TABLE OF CONTENTS

HOW TO USE THIS MANUAL	5
SYSTEM CUTOVER	6
GCP 4000 CUTOVER TEST PROCEDURE AND CHECK-OFF SHEET	6
Equipment Needed:.....	6
CIRCUIT AND PROGRAMMING VERIFICATION	6
SEAR III TESTING.....	9
MAINTENANCE CALL (MC) LIGHT	9
VERIFY OFFICE CONFIGURATION CHECK NUMBER	9
WIRE PREPARATION & INSERTION INSTRUCTIONS FOR KEYED INTERFACE CONNECTORS	9
External Wiring Connectors and Wire Size	10
Wire Preparation.....	10
Wire Insertion	10
CALIBRATION	11
RECALIBRATION/REPROGRAMMING REQUIREMENTS DUE TO MODULE REPLACEMENT	11
RECALIBRATION REQUIREMENTS DUE TO PROGRAM CHANGES.....	12
RECALIBRATION REQUIREMENTS DUE TO TRACK EQUIPMENT CHANGES.....	14
CALIBRATION PROCEDURES	16
Tuning the 62785-f Tuned Joint Coupler.....	16
Calibrating a Track Module	21
Calibrating a PSO Module.....	32
PSO Module Checkout Procedures	34
TCN and FCN	35
ADJUSTING LAMP VOLTAGES FOR SSCC IIIi.....	36
General.....	36
Meter Reading Conversion Examples.....	37
Lamp Voltage Measurement Example 1	37
Lamp Voltage Measurement Example 2	37
SSCC IIIi LAMP VOLTAGE ADJUSTMENT	39
OPERATIONAL CHECKS	41
SSCC IIIi TEST MODE	41
SSCC TEST MENU	41
Types of Tests	41
Parameters for Timed Tests.....	42
Test Status Indications	42
GCP OPERATIONAL TEST MODE	43
SSCC IIIi OPERATIONAL TESTS.....	46
SEAR IIIi SETUP	48
WAG NODE INSTALLATION	49
SEAR IIIi OPERATION	50
SEAR IIIi Communication.....	52
SEAR IIIi Alarms.....	52
TROUBLESHOOTING	54
SYSTEM STATUS INDICATORS AND LOGS.....	54
Detail View Track Status Window Color Scheme	57
Track Function Status.....	57
ISL and SSCC and System Status Indications	57
History Logs.....	58
Train Log	59
Maintenance Log.....	59
Status Log	59
Summary Log	59

SYSTEM TROUBLESHOOTING.....	60
Diagnostics	60
System Diagnostics	60
Troubleshooting the Modules	60
Release Track	81
Diagnostics Log	81
Maintenance Call Lamp Output.....	81
Transfer Output	82
Troubleshooting Flowchart	83
TESTING TRACKSIDE EQUIPMENT	85
Testing Insulated Joint Couplers	85
Testing Rail Bonds	85
Testing Termination Shunts (Hardwire, Wideband and Narrow Band (NBS)).....	86
Troubleshooting A De-Energized Predictor.....	86
High EZ and Low EX History & Calibrated Approach	87
Troubleshooting A Physical 4000 GCP Input.....	88
Troubleshooting Maintenance Call (MC) Light Problems.....	89
Nuisance Activation – Rail Phase Check	93
OUT OF SERVICE FEATURE	93
Out of Service Inputs	95
Return Track to Service.....	96
SOFTWARE VERSIONS.....	96
PROGRAMMING.....	97
PROGRAMMING THE GCP 4000.....	97
PASSWORDS	98
LOGIN USING THE FIELD PASSWORD.....	98
ATCS INFORMATION	99
ATCS Communication	99
Connecting Echelon® LONTALK Wiring.....	99
ATCS SITE ID ENTRY	100
UPLOAD SOFTWARE USING USB DEVICE	102
SET UP A USB DEVICE FOR USE	102
Creating the USB Device File Structure.....	103
INSTALLING SOFTWARE USING A USB DRIVE ...	105
A – Uploading Software onto CPU Module	105
B – Installing Software on CPU III Module	108
C – Uploading Software onto Track Module	113
D – Uploading Software onto PSO Module	113
E – Uploading Software onto RIO Module	114
F – Uploading Software onto SSCC IIIi Module	115
G – Uploading Software onto Display Module	116
CONFIGURATION FILE ACTIVITY USING USB DEVICE.....	117
A – Download Configuration File To USB Drive.....	117
B – Upload Configuration File To GCP	117
B.1 - Checking the OCCN	118
DOWNLOADING REPORTS AND LOGS	119
A – Download Configuration Report.....	119
B – Download GCP Logs	119
SEAR TRANSFERS	121
A – Installing Software on SEAR IIIi Module	121
B – CDL File Operations.....	121
C – Download SEAR Logs and Reports.....	122
D –EZ And EX Value Recording	126
D.1 – Real Time Recording of EZ and EX Values .	126
D.2 – Using Recorded EZ and EX Files	126
CHASSIS CONFIGURATIONS	127
Common Chassis Components.....	127
Track Card Compatibility	128

CPU MODULE USER INTERFACE	129
TRACK MODULE USER INTERFACE (A80418).....	134
PHASE SHIFT OVERLAY (PSO) MODULE USER INTERFACE (A80428-03).....	137
DISPLAY MODULE, A80485-1	139
SOLID-STATE CROSSING CONTROLLER (SSCC IIIi) MODULE USER INTERFACE (A80405)	140
SSCC IIIi GENERAL INFORMATION	141
Unit Overview	141
Module Function Control	141
Crossing Controller Regulation for Lamp Voltage Outputs	142
Module Health	142
Battery Surge Protection and Power Wiring.....	142
Lighting Surge Panels	143
SSCC IIIi OPERATION.....	145
Failure Operation.....	145
Crossing Controller Module Installation.....	145
Crossing Controller Connectors	146
Lamp and Bell Wiring to the Lighting Surge Panel.	147
Crossing Controller DC Power Connections	148
Connecting Power at Initial Cutover or After Changes to Warning Device Wiring	148
RELAY INPUT OUTPUT (RIO) MODULE USER INTERFACE (A80413).....	149
TRANSFER MODULES (A80406, A80468)	150
Transfer Module User Interfaces.....	151
Transfer Delay Interval Selection	153
Operation Without Transfer Module A80406.....	155
Operation Without Transfer Module A80468.....	156
APPENDIX B – OPTIONAL REMOTE CALIBRATION AND REMOTE CROSSING LAMP VOLTAGE ADJUSTMENT PROCEDURES	157
REMOTE CALIBRATION EQUIPMENT REQUIREMENTS	158
SETUP SYSTEM FOR REMOTE CALIBRATION.....	158
REMOTE CALIBRATION OPERATIONS.....	159
Remote Calibration Setup	159
Enable Remote Calibration For Track.....	160
Remote GCP Calibration	160
Remote Approach And Linearization Calibration ...	161
Remote Island Calibration	166
Remote Lamp Voltage Adjustment.....	167
Terminate Remote Calibration	170
REMOTE USER INTERFACE MENU	171
APPENDIX C – Installation of Ferrite beads.....	176
APPENDIX D – GLOSSARY	179

HOW TO USE THIS MANUAL

This handbook is intended to provide guidance to maintenance personnel. Information is provided in the indicated locations for the listed purpose:

System Cutover	Page 6
Calibration	Page 11
Operational Checks	Page 41
Troubleshooting	Page 54

WARNING

RAILROADS OR AGENCIES ARE RESPONSIBLE FOR ENSURING ONLY PROPERLY TRAINED AND/OR AUTHORIZED PERSONNEL HAVE ACCESS TO THE GCP 4000.

TRACKS MUST BE VERIFIED TO BE FREE OF ANY AND ALL TRACK RELATED ISSUES PRIOR TO BEING PLACED IN SERVICE. ANY TRACK RELATED ISSUES THAT ARE IDENTIFIED MUST BE CORRECTED AND VERIFIED TO BE CORRECT PRIOR TO PLACING THE GCP 4000 INTO SERVICE.

PROGRAM CHANGES MUST BE PERFORMED IN ACCORDANCE WITH RAILROAD PROCEDURES.

VERIFY THAT THE GCP 4000 HAS ALL PROPER COMPONENTS AND IS PROGRAMMED AS SPECIFIED BY THE RAILROAD'S OR AGENCY'S APPROVED WIRING OR INSTALLATION DIAGRAM. FAILURE TO DO SO MAY LEAD TO INCORRECT OR UNSAFE OPERATION OF THE TRACK CIRCUIT.

AFTER INSTALLATION OF A UNIT, OR WHENEVER A CHANGE IS MADE TO THE SOFTWARE OR THE CONFIGURATION, THE INSTALLATION SHOULD BE FULLY OPERATIONALLY TESTED TO ENSURE SAFETY.

SYSTEM OPERATION MUST BE VERIFIED PRIOR TO PLACING SYSTEM IN SERVICE OR FOLLOWING PROGRAMMING, HARDWARE CHANGES, OR WIRING CHANGES.

DURING INSTALLATION, CUTOVER, MODULE CHANGE OUT, MODULE SOFTWARE UPDATES, REBOOT AND CALIBRATION PROCEDURES, WARNING DEVICES MAY NOT OPERATE AS INTENDED. TAKE ALTERNATE MEANS TO WARN VEHICULAR TRAFFIC, PEDESTRIANS, AND EMPLOYEES.

SYSTEM CUTOVER

GCP 4000 CUTOVER TEST PROCEDURE AND CHECK-OFF SHEET

The Cutover Test Procedure Check-off Sheet should be used when initially installing, modifying, or after disarrangement of a GCP 4000 system and includes the SEAR Ili and SEAR Ili appliances (i.e., MTSS (Mini Track Side Sensors), Intelligent Light Out Detectors (iLODs), VHF Communicators, Ground Fault Tester (GFT), external Islands, external SSCCs, etc.)

NOTE

This procedure does not supersede procedures of the maintaining railroad. This procedure is designed to supplement railroad procedures. In case of conflicts between procedures, the most restrictive procedure should govern.

While the Diagnostic Terminal (DT) cannot be used to control the SEAR interface, SEAR programming may be accomplished through the use of a terminal emulation program. The computer is connected to the User Port on the SEAR via a male-to-female straight through cable.

Results of the tests may be documented on the GCP 4000 System Cutover Test Form, SIG-00-08-14, which is found in the rear of the Microprocessor Based Grade Crossing Predictor 4000 Family Application Guidelines, SIG-00-08-06.

Unless otherwise noted, the term 'activate crossing' means activating the flashing light signals and gates by de-energizing AND 1 XR. Do not use an Emergency Activation input unless instructed to do so.

Equipment Needed:

- Hardwire test shunt
- 0.06 ohm test shunt
- Stopwatch
- GCP 4000 Display, Web User Interface (WebUI), or PC with Diagnostic Terminal (DT) software for CPU II+ only.
- Voltmeter – Either a Agilent U1252A or equivalent with a True RMS AC + DC scale or a conventional volt-meter, which requires use of the conversion chart found in Table 18.

NOTE

It is not necessary to remove power from the GCP case before installing or removing modules. Disconnect lamp load before removing or inserting SSCC Ili modules.

CIRCUIT AND PROGRAMMING VERIFICATION

Verify the GCP 4000 modules shown on the circuit plans are properly inserted and secured into their appropriate slots (main/standby).

⚠ WARNING

THE SSCC IIII MODULES SHALL BE SECURED WITH THE BUILT IN SCREW FASTENERS.

REMOVAL OF A SSCC IIII WILL CAUSE THE GATES TO DESCEND IMMEDIATELY (WITHOUT GATE DELAY) AND THE LIGHTS WILL NOT ACTIVATE.

STEP 1

- Remove all connectors (green screw type and orange cage-clamp) from the GCP 4000.
- Close battery buss to 4000 system case.
- Verify the voltage and polarity of the B and N wiring to the GREEN plug connectors for the GCP and SSCC.
- Insert only the GREEN power plug connector above the CPU module and verify programming after system boots.
- If used, set the GCP 4000 Transfer Timer Module 80406 or Transfer Timer Assembly 80468 timer transfer switch to MAIN.
- Review the program in the GCP 4000 by using the left or right arrows and scrolling to the Program View screen, then scrolling down to or selecting option 3 to open the GCP Programming menu on the Display.
- Verify the programming per the text document in the circuit plans. Field measured parameters (approach, DAX offset and island distances, etc.) are added at this time.
 - If used, verify that the ATCS (SIN) number is per the circuit plan.
 - If used verify the office configuration check number is per the circuit plan.

NOTE

The main and standby modules do not require independent programming. Both sets of modules operate from the same stored application program. However, the main and standby modules must be individually calibrated.

STEP 2

- If used, verify the Echelon LAN wiring and termination is in place.
 - Before connecting power to other GCP connectors, verify wiring to GCP 4000 system, case wiring, wiring to surge panels, track, warning devices, and cable circuits to other locations.
- Connect track cable at house termination points.
- Connect other cable circuits at house termination points.

⚠ WARNING

DURING THE SSCC IIII BOOT-UP PROCESS AND AFTER ALL WIRING IS CONNECTED:

**THE CROSSING GATES WILL BE
DOWN WITH CROSSING LAMPS
FLASHING AND BELLS RINGING.**

**A80405 MODULE(S) WILL NOT BE
RESPONSIVE TO CROSSING
CONTROL INPUT FROM THE GCP
4000.**

**TAKE ADEQUATE PRECAUTIONS TO
WARN ANY PEDESTRIANS,
PERSONNEL, TRAINS, AND VEHICLES
IN THE AREA UNTIL PROPER SYSTEM
OPERATION IS VERIFIED.**

⚠ CAUTION

The SSCC IIIi module has active internal short circuit protection for lamp, bell and gate control outputs that is effective only after the SSCC IIIi has booted up.

Therefore, at the initial cutover it is important to boot up the system prior to connecting external loads. See connection sequence below in step 3.

Do not insert the GCP 4000 SSCC IIIi green connectors for B, N, L1, L2, GC's, bells, and inputs until directed to do so at the proper step.

Do not close the lamp, gate control, GP/GD, or bell inputs until the module health led is flashing at a 1 Hz rate, indicating that the module is healthy and ready for operation.

STEP 3

- The SSCC IIIi connectors and wiring to loads must be applied in the following sequence to avoid damage:
- Open the lamp, gate GC control, GP inputs, GD inputs and bell circuits at the surge panel(s).
- Verify battery polarity on GREEN power plugs and ORANGE input plug connector(s).
- Connect the screw-lock power connector for each SSCC IIIi module and lock by tightening screws.
- Wait approximately 40 seconds for SSCC IIIi module(s) to boot up.
- Connect the GC/bell and GP/GD ORANGE Input cage-clamp plug connectors to the appropriate SSCC IIIi.
 - Close the lamp, gate control, GP/GD inputs and bell circuits on the surge panel(s).
 - Connect warning device wiring and cables at house termination points.
- Connect all other connectors to GCP 4000 system.
- Connect all other electronic equipment to the battery busses.

SEAR Ili TESTING

Crossing Controller Failure Alarm

- Temporarily remove a SSCC Ili to generate Crossing Controller Failure alarm
- Restore SSCC Ili for a Crossing Controller Normal message.

False Detection Alarm

- Activate the crossing using test switch (or other method shown on plans) allowing the gates to drop and then cancel activation.
- After 30 minutes a False Detection alarm will be generated.
- If a normal train move occurs prior to the 30 minutes, a Pre-Ring alarm will be generated.

AC Power Off For 20 Minutes Alarm

- Turn off AC power for at least 20 minutes and this alarm will be generated.
- AC Power Back On
- Restore power and wait at least 1 minute.

This completes the SEAR Ili setup. Proceed to Maintenance Call (MC) light.

MAINTENANCE CALL (MC) LIGHT

Verify that the Maintenance Call (MC) Light, if used:

Verify that the MC extinguishes when:

- If used, Deenergizing the MAINT CALL RPT Input (observe input on I/O view).
- Restore MAINT CALL RPT input and MC lights.
- If power-off relay used to control MC light
- deenergize POK relay
- Restore POK relay and MC lights.

VERIFY OFFICE CONFIGURATION CHECK NUMBER

Verify that the office configuration check number is per the circuit plan.

- From the System View screen, scroll left or right to the **Alarms and Reports** screen
- When the Alarms and Reports screen opens, select **3 Program Report**.
- When the report opens, select **2 MCF** and Template Selection.
- When the Reports and Logs screen opens, scroll down until the Check Numbers come into view.

This completes the 4000 system check out procedure.

WIRE PREPARATION & INSERTION INSTRUCTIONS FOR KEYED INTERFACE CONNECTORS



**INCORRECT WIRING AND
INSTALLATION WILL LEAD TO
UNSAFE FUNCTIONING OF THE GCP.
THE USER MUST FOLLOW CORRECT
INSTALLATION PROCEDURES AND
PERFORM INSTALLATION TESTING TO
VERIFY CORRECTNESS OF THE
WIRING AND SYSTEM PROGRAMMING
PARAMETERS BEFORE PLACING THE
GCP IN SERVICE.**

External Wiring Connectors and Wire Size

All external wiring to a 4000 GCP Assembly is by means of plug-in connectors.

The orange cage-clamp connectors for the signal circuits should use 16 to 12 AWG wire.

The orange cage-clamp connector for the Echelon Lon Talk should use communication grade twisted wires of at least 20 AWG.

The green Screw-Lock connectors for the CPU and the SSCC should use 10 AWG wire.

Wire Preparation

Strip insulation from the end of the wire as indicated in Figure 1 below.

Table 1: Wire Strip Lengths by Connector

Type of Connection	Strip Length
Screw-down	0.28" (7 mm)
Cage clamp	0.32" – 0.35" (8 – 9 mm)

It is recommended that a stripping tool be used which allows the strip length to be set accurately. The addition of ferrules is not required. Prepare all wires in this fashion.

Wire Insertion

For screw-down type connectors:

- Insert stripped end of a wire into the wire receptor of the connector until it stops.
- Verify that no portion of the wire insulation is in contact with the wire receptor.
- Tighten screw to a torque of 4.5-inch pounds (0.5 – 0.6 Nm). (About the same tightness as required when tightening a signal terminal nut.)
- Pull on wire to determine that it does not move within the connector. (Pull with about the same amount of force as when tightening boot laces.)
- If a wire is suspected of moving when pulled, remove the wire and run the wire receptor through its full range of motion. Repeat the above steps for this wire.
- Repeat the above steps for each wire being attached to the connector.

If any wire receptor fails to hold the wire securely, replace the screw-type connector with an appropriate cage-clamp style connector.

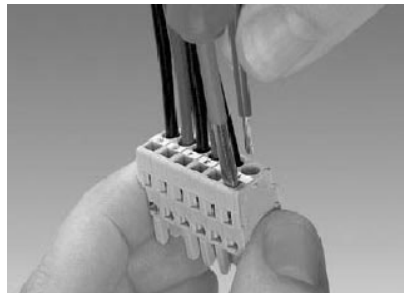

MWS_08-06_WIRE_INSERT
04-15-08

Figure 1: Inserting Wire in Cage Clamp Type Connector



Use the correct screwdriver size to prevent damage to the connector.

NOTE

The recommended flat-bladed screwdriver blade size is 0.10" wide, 0.020" thick (2.5mm x 0.5mm).

For cage clamp type connectors:

- Insert blade of appropriate sized flat bladed screwdriver in rectangular slot in connector next to the wire receptor (see Figure 1).
- Lever the wire cage clamp open by pressing straight down on the screwdriver.
- Insert the stripped end of a wire into the fully-open wire receptor until it stops.
- Hold the wire in place and remove the screwdriver blade from the slot. The wire clamp closes down on the stripped end of the wire.

CALIBRATION

The GCP 4000 is programmed using the A80485-1 Display Module, the Web User Interface (WebUI), or the Diagnostic Terminal (DT) (CPU II+). The DT is operated via laptop connection to the Diag Port on the top half of the case. DT is only compatible with CPU II+ operation. The WebUI is connected via the Laptop port on the front of the CPU III unit, using an Ethernet cable, or connected to an Ethernet port on the front of the Display. Use of WebUI is required if product being used with a CPU III (A80903).

GCP 4000 System Calibration consists of GCP calibration, SSCC lamp adjustment, and system checkout.

WARNING

IF ISLAND STATUS IS CHANGED FROM NO TO INTERNAL, ISLAND RECALIBRATION MAY BE REQUIRED.

NOTE

If the CPU module MCF is changed, requisite programming and recalibration will be required. For additional information, reference the following tables.

RECALIBRATION/REPROGRAMMING REQUIREMENTS DUE TO MODULE REPLACEMENT

The recalibration requirements due to the replacement of a module are shown in the following table.

NOTE

When using MCF gcp-t6x-02-2.mcf or newer, Tables 2, 3, and 4 have been updated to include reprogramming instructions for the new PSO module.

Table 2: Recalibration & Reprogramming Requirements Due to Module/Chassis Replacements

Module /Assembly Replacement		Calibration Required					Reprogramming Required
		GCP CAL	GCP APP	GCP LIN	ISL CAL	PSO	
A80403 or A80903	CPU	No	No	No	No	No	No
A40418	Track	Yes ¹	Yes/No ²	Yes/No ²	Yes	No	No
A80428-03	PSO	No	No	No	No	Yes	No
A80413	RIO (I/O)	No	No	No	No	No	No
A80406	Transfer	No	No	No	No	No	No
A80405	SSCC ⁵	No	No	No	No	No	No
A80485-1	Display	No	No	No	No	No	No
A80410	SEAR	No	No	No	No	No	Yes ³
A80435	ECD ⁴	No	No	No	No	No	No
n/a	Chassis	Yes	Yes	Yes	Yes	No	Yes

Notes:

1. For track with changed A80418.
2. May be bypassed using **BYPASS** button instead of the **START** button in calibration procedure.
3. Site Setup required and customer CDLs will need to be reloaded.
4. Plug-in located on chassis behind CPU Module. Requires same MCF as previously in use.
5. SSCC lamp voltages must be readjusted

RECALIBRATION REQUIREMENTS DUE TO PROGRAM CHANGES

The GCP program changes that require track recalibration are indicated in the following table.

Table 3: Recalibration Requirements Due to Program Changes

Program Changes	Calibration Required					Reprogramming Required
	GCP CAL	GCP APP	GCP LIN	ISL CAL	PSO CAL	
Increased Number of Tracks	Yes ¹	Yes ¹	Yes ¹	Yes ²	Yes ¹	Yes ¹
GCP Frequency Change	Yes ³	Yes ³	Yes ³	No	No	No
Island Frequency change	No	No	No	Yes ⁴	No	No
PSO Frequency Changed	No	No	No	No	Yes	No
Application changed: Unidirectional to Bidirectional, Bidirectional to Unidirectional or Unidirectional to Simulated Bidirectional	Yes ⁵	Yes ⁵	Yes ⁵	No	No	No
Transmit Level Changed						
Approach Distance Changed						
Ballast Compensation Value Changed						
Island Operation Changed from No to Internal or from Internal to No	Yes ⁶	No ⁷	No ⁷	Yes ⁸	No	No
Template Changed	Yes ⁹	Yes ⁹	Yes ⁹	Yes ⁹	Yes	Yes ¹⁰
Template Set to Default selected						
New Software Installed:						
• Track MEF changed	No ^{11,12}	No ⁷	No ⁷	No ^{11,12}	No	No
• Other MEFs changed	No	No	No	No	No	No
• System MCF changed	Yes ⁹	Yes ⁹	Yes ⁹	Yes ⁹	Yes ⁹	Yes ¹⁰
• PSO MEF changed	No	No	No	No	Yes ⁵	No

Table 3: Recalibration Requirements Due to Program Changes

Notes:

1. For added tracks only.
2. If island is used.
3. For tracks with new GCP frequencies.
4. For tracks with new island frequencies.
5. For changed tracks only.
6. If EZ varies more than 2.
7. Can be bypassed.
8. If changed to internal.
9. For all tracks.
10. Complete reprogramming is required. This does not apply if the changed software is any of the MEF (executive software) files but will apply if the MCF (application logic) was changed.
11. In general GCP and ISL calibration is not required when software is updated. However, in some cases due to the nature of the change, it may be necessary to force a recalibration, in this case the module will show that calibration is required after the new software has been loaded. Approach and Linearization can be bypassed after GCP calibration has been performed.
12. Calibration may be needed, check Product Release Bulletin (PRB) associated with release for specific conditions, for example an update to GCP04_80.mef, requires recalibration, see PRB0539. Approach and Linearization can be bypassed after GCP calibration has been performed.

NOTE: Uploading a new PAC may require re-calibration

RECALIBRATION REQUIREMENTS DUE TO TRACK EQUIPMENT CHANGES

Changes made to the existing track equipment that require track recalibration are shown in the following table.

Table 4: Recalibration Requirements Due to Track Equipment Changes

Track Equipment Changes	Calibration Required				
	GCP CAL	GCP APP	GCP LIN	ISL CAL	PSO CAL
Termination Shunts Changed	Yes ¹	No ³	No ³	No	Yes
Termination Shunts Moved to New Location	Yes ¹	Yes ¹	Yes ¹	No	Yes
Change of shunt or frequency in overlapping territory	Yes ¹	Yes ¹	Yes ¹	No	Yes
Termination Shunts of Other Frequencies Added, Removed From, or Moved Within the 4000 GCP Approaches)	Yes ¹	Yes ¹	Yes ¹	No	Yes
Wide band Insulated Joint Couplers (8A076 or 8A077) Replaced in 4000 GCP Approaches)	Yes ¹	No ^{2,3}	No ^{2,3}	No	Yes ¹
Tuned Insulated Joint Couplers (62785-f) Replaced in 4000 GCP Approaches)	Yes ¹	Yes ¹	Yes ¹	No	Yes
4000 GCP Track Wire(s) Replaced, Disarranged, and/or Modified	Yes ¹	No ^{2,3}	No ^{2,3}	Yes	Yes
Change of Insulated Joint Bypass Coupler (Tuned) 7A422-f	Yes	Yes	Yes	No	Yes
Notes: 1. For changed tracks only. 2. Maybe bypassed. 3. If, after completing maintenance and reconnecting Track Wires, the EZ/EX returns to the previous value, approach or linearization recalibrations are not required. But if the values are different, recalibrate the approach or linearization.					

NOTE

Approach distance in the Program menu must be changed to reflect the new approach distance prior to start of track calibration. Otherwise, the system will prompt for recalibration.

CALIBRATION PROCEDURES

⚠ WARNING

GCP TRACKS MUST BE VERIFIED TO BE FREE OF ANY AND ALL TRACK RELATED ISSUES PRIOR TO BEING PLACED IN SERVICE. ANY TRACK RELATED ISSUES THAT ARE IDENTIFIED MUST BE CORRECTED AND VERIFIED TO BE CORRECT PRIOR TO FINAL CALIBRATION AND LINEARIZATION.

NOTE

If the outlined procedures fail, they should be repeated once. If the error repeats, refer to the Troubleshooting section.

GCP calibration is divided into the following procedures:

- Tuning the Tuned Joint Coupler (TJC)
- GCP Calibration (GCP)
- Approach Distance Calibration (Approach)
- Linearization Steps Calibration (Linearization)
- Island Calibration (Island)

⚠ WARNING

THE APPROACH AND LINEARIZATION PROCEDURES REQUIRE THE RECORDING OF THE COMPUTED APPROACH DISTANCES IN FEET (NOT THE EZ VALUE).

WHEN EDITING THE COMPUTED APPROACH DISTANCES, ENTER THE VALUE IN FEET (NOT THE EZ VALUE).

FAILURE TO ENTER DISTANCES IN FEET MAY RESULT IN SHORTER WARNING TIMES THAN INTENDED.

PERFORM THE FOLLOWING TUNING PROCEDURES ON THE TUNED JOINT COUPLER PRIOR TO BEGINNING THE LINEARIZATION PROCESS.

Tuning the 62785-f Tuned Joint Coupler

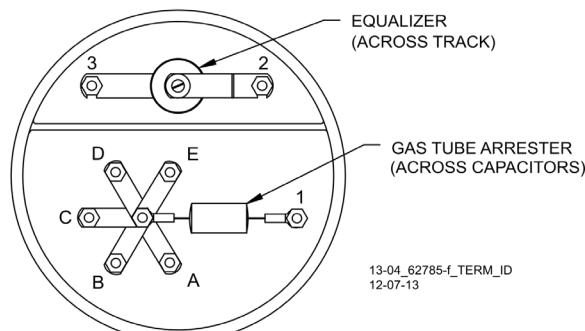

Figure 2: Tuned Joint Coupler, 62785-f

The Tunable Insulated Joint Bypass Coupler, 62785-f is the only tuned bypass coupler to be used with the GCP 4000 for bypassing insulated joints in DC coded track. The 62785-f Coupler is available in standard Siemens frequencies of 156 Hz through 970 Hz. The -f on the part number is the coupler's frequency and must match the frequency specified in the circuit book. This coupler is tuned during commissioning to pass the GCP 4000 operating frequency (f) around insulated rail joins in DC or coded DC track circuits.

⚠ WARNING

INSULATED JOINT BYPASS COUPLERS, 62531-F AND 62631-F, MUST NOT BE USED WITH THE 4000 GCP.

THE MINIMUM DISTANCES TO THE INSULATED JOINTS SPECIFIED IN TABLE 5 APPLY TO THE 3000/4000 GCP ONLY; NOT TO ANY EARLIER SIEMENS GCP'S (MODELS 660, 600, 400, AND 300).

WHEN THE 4000 GCP IS PROGRAMMED AS A PREDICTOR, THE 62785-F COUPLER CANNOT BE USED TO BYPASS INSULATED JOINTS WITHIN THE INNER TWO-THIRDS OF AN APPROACH, EXCEPT AS SPECIFIED IN TABLE 5.

THE TUNED JOINT COUPLER MUST BE TUNED PRIOR TO PERFORMING SETUP FOR APPROACH LENGTH AND LINEARIZATION PROCEDURES DURING THE TRACK CALIBRATION PROCESS.

62785-F TUNED BYPASS COUPLERS MUST ONLY BE USED TO BYPASS INSULATED JOINTS IN CODED OR NON-CODED DC TRACK CIRCUITS.

The application guidelines for Tunable Insulated Joint Bypass Coupler, 62785-f when used only with the 4000 GCP have been expanded as follows:

- In DC coded track circuits, the insulated joints within an approach may be bypassed using the Siemens 62785-f Tunable Insulated Joint Bypass Coupler, provided the minimum distances specified in Table 5 are observed.
- The 62785-f Coupler must be field tuned to pass the 4000 GCP operating frequency (f) around insulated joints in DC or coded DC track circuits.
- Field tuning of the Coupler enables precise frequency adjustment for track and joint parameters.
- The Coupler must be located within 10 ft. (3.04 m) of the insulated joints that it is coupling.
- The minimum distance to the insulated joints is generally a function of the 4000 GCP operating frequency, i.e., the lower the operating frequency, the longer the minimum distance.

Two sets of insulated joints may be coupled in any single approach, provided the minimum operating distances specified in Table 5 are observed.

Table 5 indicates the minimum operating distances (in feet/meters) to the first and second set of insulated joints that are coupled with 62785-f couplers for 4000 GCP operation.

⚠ WARNING

AT THE COMPLETION OF FIELD TUNING THE 62785-F BYPASS COUPLERS, ENSURE THAT A STANDARD AREMA NUT IS TIGHTENED SECURELY AGAINST EACH GOLD NUT ON TERMINALS A THROUGH E, INCLUDING THE TERMINALS THAT ARE NOT TIGHTENED DOWN.

NOTE

While field tuning the 62785-f Bypass Coupler, tightening the nut on terminal E produces maximum change in EZ value. Tightening the nut on terminal A produces minimum change.

The 62785-f Coupler is tuned by means of five standard AREMA binding posts

- AREMA binding posts are labeled A through E (see Figure 2).
- AREMA binding posts are equipped with special gold AREMA adjustment nuts.

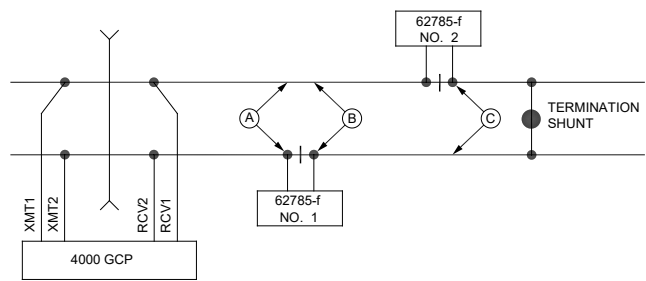

Staggered Insulated Joints

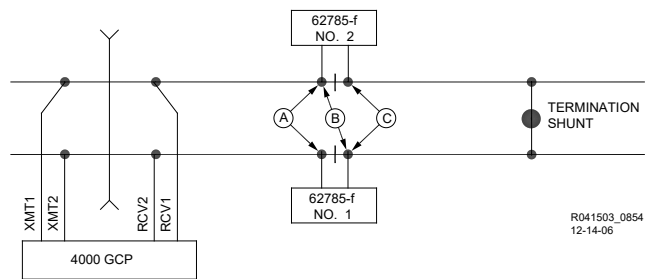

Non-Staggered Insulated Joints

Figure 3: Shunt Placement For 62785-f Bypass Coupler

Table 5: Tuned Joint Coupler, 62785-f Minimum Distances

Frequency (Hz)	Minimum Distance to 1st Set of Insulated Joints (Feet/Meters)*	Minimum Distance to 2nd Set of Insulated Joints (Feet/Meters)*
151 to 211	1500 (457.2)	2200 (670.6)
212 to 348	1000 (304.8)	1400 (426.7)
349 to 560	700 (213.4)	1000 (304.8)
561 to 790	500 (152.4)	800 (243.8)
791 to 979	400 (121.9)	700 (213.4)
<p>* Distance applies to insulated joints located on the same side of the crossing.</p> <p>NOTE: Frequencies of 86 and 114 Hz are not available with the 62785-f coupler. Contact Siemens Rail Technical Support (1-800-793-7233) for these applications.</p>		

Table 6: Method 1 for Tuning the 62785-f Tuned Joint Coupler

See Figure 3 above for locations referred to in this table.	
Step 1	Tighten the gold nut securely on terminal E of each coupler.
Step 2	Calibrate the 4000 GCP, setting the EZ value to 100.
Step 3	Place a hardwire test shunt across the track at location A.
Step 4	Note the EZ value appearing on the 4000 GCP display.
Step 5	Move the test shunt to location B.
Step 6	<p>Tune the Tunable Insulated Joint Bypass Coupler #1 to the same EZ value noted in Step 4.</p> <p>Tighten the gold nut on the Coupler #1 terminals labeled D, C, B, and A, in sequence beginning with terminal D.</p> <p>If tightening a nut results in an EZ value that is lower than the value recorded in Step 4, loosen the nut and tighten the next nut in sequence.</p> <p>If, after tightening a nut, the EZ value remains higher than the value recorded in Step 4, leave the nut tightened and tighten the next nut in sequence.</p> <p>Continue to tighten nuts D through A as necessary to obtain an EZ value that is approximately the same as that recorded in Step 4.</p>
Step 7	Move the test shunt to location C.
Step 8	<p>Tune the No. 2 Tunable Insulated Joint Bypass Coupler to the EZ value noted in step 4.</p> <p>Tighten the gold nut on the Coupler #2 terminals labeled D, C, B, and A, in sequence beginning with terminal D.</p> <p>If tightening a nut results in an EZ value that is</p>

Table 6: Method 1 for Tuning the 62785-f Tuned Joint Coupler

	<p>lower than the value recorded in step 4, loosen the nut and tighten the next nut in sequence.</p> <p>If, after tightening a nut, the EZ value remains higher than the value recorded in step 4, leave the nut tightened and tighten the next nut in sequence.</p> <p>Continue to tighten nuts D through A as necessary to obtain an EZ value that is approximately the same as that recorded in step 4.</p>
Step 9	Remove the test shunt.
Step 10	Tighten a standard AREMA nut against each gold nut of both couplers to ensure all nuts are securely locked in position.
Step 11	Secure the end caps over the terminal end of both couplers.
Step 12	Completely recalibrate the 4000 GCP and perform all operational checks.
Step 13	Verify that a smooth change in the EZ value occurs across the couplers during a train move.

Table 7: Method 2 for Tuning the 62785-f Tuned Joint Coupler

See Figure 3 above for locations referred to in this table.	
Step 1	Tighten the gold nut securely on terminal E of each coupler.
Step 2	Calibrate the 4000 GCP, setting the EZ value to 100.
Step 3	Place a hardwire test shunt across the track at location A.
Step 4	Note the EZ and EX values appearing on the 4000 GCP display.
Step 5	Move the test shunt to location B.
Step 6	Tune the Tunable Insulated Joint Bypass Coupler #1 EX value to above 75. The EZ value may be as much as 8 points above the value noted in Step 4.
Step 7	Move the test shunt to location C.
Step 8	Tune the Tunable Insulated Joint Bypass Coupler #2 EX value to above 75. The EZ value may be as much as 16 points above the value noted in Step 4.
Step 9	Remove the test shunt.
Step 10	Tighten a standard AREMA nut against each gold nut of both couplers to ensure all nuts are securely locked in position.
Step 11	Secure the end caps over the terminal end of both couplers.
Step 12	Completely recalibrate the 4000 GCP and perform all operational checks.
Step 13	Verify that a smooth change in the EZ value occurs across the couplers during a train move.

Calibrating a Track Module

WARNING

DO NOT RECALIBRATE IF AN IN-SERVICE TRACK SUDDENLY HAS A LARGE JUMP IN EZ OR HIGH SIGNAL ERROR.

THE CAUSE MAY BE A TRACK, BOND, COUPLER OR SHUNT RELATED PROBLEM WHICH MUST BE INVESTIGATED AND CORRECTED BEFORE CONSIDERING RECALIBRATION.

BEFORE STARTING CALIBRATION, ENSURE THAT TRACK BONDING IS GOOD, THAT ALL TERMINATION SHUNTS, INSULATED JOINT COUPLERS, AND TRACK ISOLATION DEVICES ARE INSTALLED AND THAT NO TRAINS ARE IN THE GCP APPROACHES.

NOTE

During approach calibration of the GCP 4000, when the island is de-energized, the EX value is locked to 100. During a new installation, an upgrade, or a Track Card replacement, with the EX locked at 100 the EZ may appear abnormally low. Once the island is energized, the EX unlocks and the EX and EZ display actual approach values based upon field conditions. The island for a given track module does not necessarily have to be on that particular module (or any module if an external island), depending upon circuit arrangement.

Track Module calibration is required if the Display's:

- Track Detail screen depicts:
 - GCP Calib Req
 - Island Calib Req
- On the Calibration screens depict:
 - GCP Calib Req
 - Approach Calib Req
 - Linearization Calib Req
 - Island Calib Req
- During Calibration, the Track Module 4-character display shows one of the following:
 - GCAL
 - GAPP
 - GLIN
 - ICAL

The Calibration screen indicates which calibrations are required with an empty box in each calibration select button. A check mark is displayed in the box when the indicated calibration is complete.

Table 8: GCP Calibration

Step 1	If system has a transfer module, set the transfer switch to MAIN .
Step 2	If a 60 or 100 Hz Cab Signal is in use, turn it off at this time.
Step 3	From the System View menu, select the track to calibrate, i.e., 1 – 6 by entering that number on the keypad. The menu shows only enabled tracks.
Step 4	From the Track Options menu, select 3) Calibration . The Track “N” Window appears, depicting the Calibration status of: 1) GCP , along with EZ and EX values 2) Approach , along with Computed Distance 3) Linearization , along with Linearization Steps 4) Island , along with Island Status and Z Level If Calib Required appears on any of the above lines, calibration is required.
Step 5	Select 1) GCP . The Track “N” GCP Calibration Window opens, listing 1) Start Calibration and 2) Add Comment. Select 1) Start Calibration . The display depicts Initiating , then In Progress messages during the calibration. If calibration is successful: <ul style="list-style-type: none"> • Passed, please wait appears in the window. • EZ should be 98 to 102 and the 1) GCP line has a green check next to Calibrated. If calibration is not successful, the display shows a Failed message. If a Failed message is received, try the calibration again. If it fails a second time, verify that the wiring is correct.
Step 6	To record the reason for the recalibration in the Maintenance log, select 3) Calibration . <ul style="list-style-type: none"> • The Track “N” Window appears. • Select 2) Add Comment. • On the Enter Text tile, type any notes concerning the reason and select Enter.
Step 7	If the cab signal was turned off in Step 2, turn it on.

The linearization procedure compensates for lumped loads in the GCP 4000 approach that can affect the linearity of EZ over the length of the approach as a train approaches the crossing. The linearization is essential to improving warning time accuracy. Linearization may be affected by narrow band shunts in other frequencies, which may occur when other GCP approaches overlap the GCP approach circuit; other track equipment in the GCP approach such as audio frequency overly track circuits, coded track circuits, etc.; and missing or incorrect track battery chokes.



USE THE FOLLOWING BYPASS PROCEDURE ONLY IF THE CURRENT COMPUTED APPROACH DISTANCE AND LINEARIZATION VALUES ARE KNOWN TO BE CORRECT.

NOTE

If an in-service 4000 GCP requires only that the GCP Calibration procedure be performed, the BYPASS procedure must be completed for both **Approach** and **Linearization**.

Table 9: Approach & Linearization Calibration Bypass Procedure

Step 1	Once GCP Calibration is completed, bypass the approach calibration by first selecting 2) Approach . After the Track “N” Approach Calibration Window opens, select 3) Bypass . Do not select 1) Start Calibration .
Step 2	Bypass the linearization calibration by first selecting 2) Approach . After the Track “N” Linearization Calibration Window opens, select 3) Bypass . Do not select 1) Start Calibration .

WARNING

THE APPROACH AND LINEARIZATION PROCEDURES REQUIRE THE RECORDING OF THE COMPUTED APPROACH DISTANCES IN FEET (NOT THE EZ VALUE). FAILURE TO ENTER DISTANCES IN FEET MAY RESULT IN SHORTER WARNING TIMES THAN INTENDED.

NOTE

Calibration Distance and Linearization Steps values are site historical data and must be recorded as specified in Table 10 in

Table 11: Calibration Value History Form, 1st Approach

& 6 in this manual as well as in Figures 1 & 2 on both the History Card and the Site Cutover form.

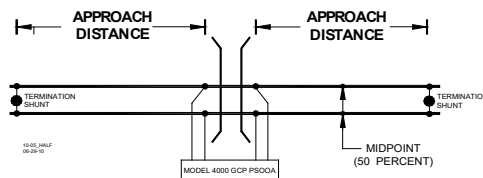

Figure 4: Midpoint Location (See Step 6 below)

Table 10: Approach Distance and Linearization Calibration

Step 1	Record the EZ and EX values for the track (before installing hardwire shunt) in the Step 1 Step 2 column (Calibrated Values) on Table 11: Calibration Value History Form, 1st Approach form at the end of this procedure. Temporarily place a hardwire shunt across the termination shunt. For bidirectional installations, use the termination shunt furthest from the crossing.
Step 2	Record the EZ and EX values for the track in the First Approach, Step 2 column on Table 11: Calibration Value History Form, 1st Approach
Step 3	Select 2) Approach . The Track “N” Approach Calibration Window opens, listing 1) Start Calibration, 2) Edit and 3) Add Comment .
Step 4	Select 1) Start Calibration . The display reports Initiating , then In Progress during the calibration. If calibration is successful: <ul style="list-style-type: none"> • Passed, please wait appears in the window, followed by Calibrated. • The Computed Distance value appears and the 2) Approach line has a green check next to Calibrated. If calibration is not successful, the display shows a Failed message.
Step 5	Record the computed approach distance in feet for the track in the First Approach, Step 5 column (Computed Distance) on Table 11: Calibration Value History Form, 1st Approach at the end of this procedure.
Step 6	Accurately (within 1%) locate the midpoint of the longest approach and move the hardwire shunt to that point on the rails.
Step 7	Select 3) Linearization . The Track “N” Linearization Calibration Window opens, listing 1) Start Calibration, 2) Edit, 3) Bypass and 4) Add Comment .
Step 8	Select 1) Start Calibration . The display reports Initiating , then In Progress during the calibration. If calibration is successful: <ul style="list-style-type: none"> • Passed, please wait appears in the window, followed by Calibrated. • The Linearization Steps value appears and the 3) Linearization line has a green check next to Calibrated. If calibration is not successful, the display shows a Failed message.
Step 9	Record the linearization step value for the track in the First Approach, Step 9 column (Linearization Steps) on Table 11: Calibration Value History Form, 1st Approach at the end of this procedure. The value should be between 68 and 132. If not, refer to Troubleshooting.

Table 10: Approach Distance and Linearization Calibration

Step 10	Verify that the computed approach distance in feet (Computed Distance, Step 5) and the linearization steps (Linearization Steps, Step 9) values recorded Table 11: Calibration Value History Form, 1st Approach are the same as the values displayed on the Track “N” window.
Step 11	Remove the hardwire shunt from the track.
Step 12	If the approach is unidirectional or simulated bidirectional, go to step 31. If the track is bidirectional go to step 13.
Step 13	Temporarily place a hardwire shunt across the termination shunt of the other approach.
Step 14	Record the EZ and EX values for the track in the Second Approach, Step 14 column Table 12:Calibration Value History Form 2nd Approach.
Step 15	Select 2) Approach . The Track “N” Approach Calibration Window opens, listing 1) Start Calibration, 2) Edit and 3) Add Comment .
Step 16	Select 1) Start Calibration . The display reports Initiating , then In Progress during the calibration. If calibration is successful: <ul style="list-style-type: none"> • Passed, please wait appears in the window, followed by Calibrated. • The Computed Distance value appears and the 2) Approach line has a green check next to Calibrated. If calibration is not successful, the display shows a Failed message.
Step 17	Record the computed approach distance in feet in the Second Approach, Step 17 column on Table 12:Calibration Value History Form 2nd Approach at the end of this procedure.
Step 18	Accurately (within 1%) locate the midpoint of this approach and move the hardwire shunt to that point on the rails.
Step 19	Select 3) Linearization . The Track “N” Linearization Calibration Window opens, listing 1) Start Calibration, 2) Edit, 3) Bypass and 4) Add Comment
Step 20	Select 1) Start Calibration . The display reports Initiating , then In Progress during the calibration. If calibration is successful: <ul style="list-style-type: none"> • Passed, please wait appears in the window, followed by Calibrated. • The Linearization Steps value appears and the 2) Approach line has a green check next to Calibrated. If calibration is not successful, the display shows a Failed message.

Table 10: Approach Distance and Linearization Calibration

Step 21	<p>Record the linearization (Linearization Steps) value (between 68 and 132) for the track in the Second Approach, Step 21 column (Linearization Steps) on Table 12: Calibration Value History Form 2nd Approach at the end of this procedure.</p> <p>Verify that the computed approach distance in feet (Computed Distance, step 17) and the linearization steps (Linearization Steps, step 21) values recorded are the same as the values displayed on the Calibration Select window.</p>
Step 22	<p>Remove the hardwire shunt from the track.</p>
Step 23	<p>If the Linearization Steps value for the second approach (step 21, Figure 6) is greater than or the same as the Linearization Steps value recorded for the first approach (step 9, Figure 5), go to step 31. If the Linearization Steps value for the second approach (step 21, Figure 6) is less than the value recorded for the first approach (step 9, Figure 5), go to step 24.</p>
Step 24	<p>Select 3) Linearization. The Track “N” Linearization Calibration Window opens, listing 1) Start Calibration, 2) Edit, and 3) Add Comment</p>
Step 25	<p>Select 2) Edit The New value dialog box appears.</p>
Step 26	<p>Enter the Linearization Steps value recorded on Table 11: Calibration Value History Form, 1st Approach for the first approach (step 9) into the New Value field using the keypad numbers and select ENTER. The entered value appears on 3) Linearization.</p>
Step 27	<p>Select 2) Approach. The Track “N” Approach Calibration Window opens, listing 1) Start Calibration, 2) Edit and 3) Add Comment.</p>
Step 28	<p>Select 2) Edit. The New value box appears.</p>
Step 29	<p>Enter the computed approach distance value recorded for the first approach (step 5, Figure 5) into the New Value field using the keypad numbers and select ENTER.</p> <ul style="list-style-type: none"> The entered value appears on 2) Approach.
Step 30	<p>Verify that the computed approach distance (Computed Distance, step 5) and the linearization steps (Linearization Steps, step 9) values recorded on Table 11: Calibration Value History Form, 1st Approach for the first approach are the same as those displayed on the Track “N” window.</p>

Table 10: Approach Distance and Linearization Calibration

Step 31	Transfer the information written in Table 11: Calibration Value History Form, 1st Approach and Table 12: Calibration Value History Form 2nd Approach below onto Figure 1 and Figure 2 of the GCP 4000 Application History Card, SIG-00-04-21 and Figure 1 and Figure 2 of the GCP 4000 System Cutover Test Procedure and Check Off Sheet, both of which are found at the back of the GCP 4000 Family Application Guidelines Manual, SIG-00-08-10. If the initial settings of the GCP were changed or equipment changes were made such that require recalibration of the GCP, Approach, and Linearization, place the updated Computed Distance and Linearization Steps data in Figure 3 and Figure 4 of the History Card.
Step 32	To record the reason for the Calibration and store it in the Maintenance log, select 3) Linearization and then 3) Add Comment . <ul style="list-style-type: none"> Type any notes about the calibration and select Enter to save the entry.

Table 11: Calibration Value History Form, 1st Approach

	Calibrated Values (Step 1)		1 st Approach E/W() (N/S			
			Hardwire Across Termination Shunt (Step 2)		Computed Approach Distance (Ft) (Computed Distance) (Step 5)	Linearization Step Value (Linearization Steps) (Step 9)
			EZ	EX		
Track 1						
Track 2						
Track 3						
Track 4						
Track 5						
Track 6						

Table 12: Calibration Value History Form 2nd Approach

	Calibrated Values (Step 1)		2 nd Approach E/W() (N/S			
			Hardwire Across Termination Shunt (Step 14)		Computed Approach Distance (Ft) (Computed Distance) (Step 17)	Linearization Step Value (Linearization Steps) (Step 21)
			EZ	EX		
Track 1						
Track 2						
Track 3						
Track 4						
Track 5						
Track 6						

NOTE

This completes **Approach and Linearization Calibration**. If the system includes an internal island, proceed to **Island Calibration (Island)**. If not, proceed to Table 15.

The island can be calibrated to respond to a shunting sensitivity of 0.12, 0.3, 0.4, or 0.5 ohms. A hardwire shunt is used for calibration.

NOTE

Island track circuit calibration is generally performed using 0.12 ohm shunting sensitivity. In an area where poor shunting is experienced or anticipated, a minimum of 0.3 ohm shunting sensitivity is recommended.

In areas of passenger operation, a minimum of 0.3 ohm shunting sensitivity is recommended.

Table 13: Island Calibration

Step 1	If an Island circuit is used, select 4) Island from the Track Menu. <ul style="list-style-type: none">• The ISLAND CALIBRATION Window appears.
Step 2	Temporarily install a hardwire shunt beyond the island receiver rail connections at the appropriate distance specified below the Calibration Required message. <ul style="list-style-type: none">• Shunt distances for island frequencies are provided in the table following the Island Calibration procedure. The appropriate ones for the configured island frequency are also shown on the calibration screen as shown in Figure 5.• Ensure EZ value is less than or equal to 5. See Figure 6.

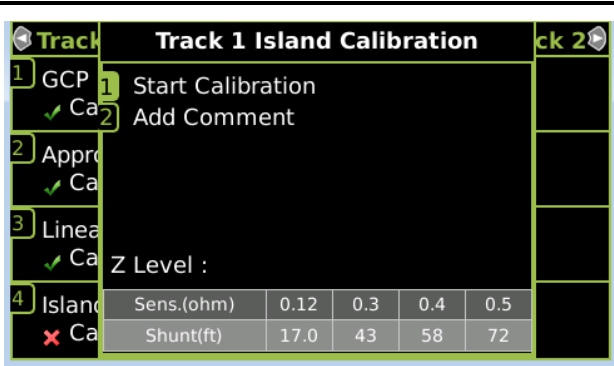

Figure 5 Island Calibration Window

Step 3	<p>Select 1) Start Calibration. The display reports Initiating, then In Progress during the calibration.</p> <p>If calibration is successful:</p> <ul style="list-style-type: none"> • Passed, Please Wait appears in the window, followed by Calibrated. • The Z Level value appears and the 4) Island line has a green check next to Calibrated. • If calibration is not successful, the display shows a Failed message (see Troubleshooting).
Step 4	<p>Verify that the Island indicator on the 4) Island line is grey and remove the hardwire shunt.</p> <ul style="list-style-type: none"> • The island indicator is now green.

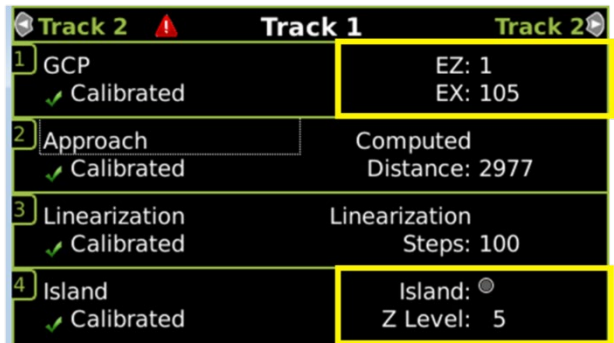

Figure 6 Track Detail View EZ Level and Island Z Level

Table 13: Island Calibration

Step 5	Ensure that no external equipment is connected to the serial port on the track board.
Step 6	Following railroad policies concerning the use of jumper wires. Place a jumper wire across the RCV1 and RCV2 receiver wires at the main terminal board and verify the EZ value is less than or equal to 5. If the EZ value is greater than 5 and the jumper is confirmed to be securely connected, use additional jumper wires in parallel until an EZ less than or equal to 5 is achieved. The crossing should activate. Note the Island Z value with the jumper applied. See Figure 6.
Step 7	Remove the jumper(s) and allow the crossing to recover.

Table 13: Island Calibration

Step 8	Following railroad policies concerning the use of jumper wires. Place a jumper wire across the XMT1 and XMT2 transmitter wires at the main terminal board and verify the EZ value is less than or equal to 5. If the EZ value is greater than 5 and the jumper is confirmed to be securely connected, use additional jumper wires in parallel until an EZ less than or equal to 5 is achieved. The crossing should activate. Note the Island Z value with the jumper applied.
Step 9	Remove the jumper(s) and allow the crossing to recover.
Step 10	If either Island Z value is 40 or greater, remove the board from service and contact Siemens Rail Automation Technical Support at (800) 793-7233 Option 1. Inform the operator you have a track board that failed functional checks for Island Z value. Be prepared to provide the following information: <ol style="list-style-type: none"> 1. Your contact information 2. Part number 3. Serial number and hardware version 4. The EZ and Island Z values recorded during the test.

Table 14: Island Shunt Distance

Island Freq. (kHz)	Shunt Distance (Feet/Meters)			
	0.12 ohm Sensitivity	0.3 ohm Sensitivity	0.4 ohm Sensitivity	0.5 ohm Sensitivity
2.14	20/6.10	50/15.24	67/20.42	84/25.60
2.63	17/5.18	43/13.11	58/17.68	72/21.95
3.24	13/3.96	33/10.06	44/13.41	55/16.76
4.0	10.5/3.20	27/8.23	36/10.97	45/13.72
4.9	9.0/2.74	23/7.01	31/9.45	39/11.89
5.9	7.5/2.29	19/5.79	26/7.92	32/9.75
7.1	6.5/1.98	17/5.18	23/7.01	29/8.84
8.3	6.0/1.82	15/4.57	20/6.10	25/7.62
10.0	5.0/1.50	13/3.96	18/5.49	22/6.71
11.5	4.5/1.37	12/3.66	16/4.88	20/6.10
13.2	4.0/1.22	10/3.20	14/4.27	17/5.18
15.2	3.5/1.07	9/2.74	12/3.66	15/4.57
17.5	3.0/0.91	8/2.44	11/3.35	14/4.27
20.2	3.0/0.91	8/2.44	11/3.35	14/4.27



WHEN USING SSCC IIII MEFXNG02_00 OR EARLIER, GATES WILL BEGIN TO LOWER IMMEDIATELY (WITHOUT GATE DELAY TIME) WHEN THE TRANSFER SWITCH IS USED TO SWAP BETWEEN HEALTHY UNITS. USE CAUTION WHEN TRANSFERRING CONTROL TO AVOID GATES HITTING VEHICLES OR PEDESTRIANS.

NOTE

Under normal conditions in the AUTO Transfer mode, gate delay time will run when the gates initially operate. If the trouble continues, the gates will already be lowered when the Transfer Module later swaps units.

Repeat all GCP, Approach, Linearization, and Island calibration steps for each standby sidetrack module installed.

Table 15: Standby Modules Calibration

Step 1	On Transfer module A80468, set the transfer switch to STBY .
Step 2	If a 60 or 100 Hz Cab Signal is in use, turn it off at this time.
Step 3	From the System View menu, select the track to calibrate, i.e., 1 -6 by entering that number on the keypad. The menu shows only enabled tracks.
Step 4	From the Track Options menu, select 3) Calibration . The Track "N" Window appears, depicting the Calibration status of: 1) GCP, along with EZ and EX values 2) Approach, along with Computed Distance 3) Linearization, along with Linearization Steps 4) Island, along with Island Status and Island Z Level If Calibration Required appears on any of the above lines, calibration is required.
Step 5	Follow the Calibration steps listed in Table 8: GCP Calibration.
Step 6	Follow the Calibration steps listed in Table 9: Approach & Linearization Calibration Bypass Procedure.
Step 7	Fill out the Calibration steps listed in Table 11: Calibration Value History Form, 1st Approach for the first approach, then the steps in Table 12 for the second approach.
Step 8	Follow the Calibration steps in Table 13: Island Calibration to complete the Calibration process for the Standby Module.
Step 9	To record the reason for the Calibration and store it in the event log, select the appropriate Menu item (1-4) and then 4) Add Comment . Type any notes about the calibration and select Enter to save the entry.
Step 10	Repeat Steps 1 through 8 if other standby-side Track Modules are installed.

Calibrating a PSO Module

With the PSO Module properly installed and programmed per the railroad's or agency's written instructions, calibrate the receiver (RX1 or RX2) as follows:

Table 16: PSO Module Calibration

Step 1	When the track ballast is good, connect a track test shunt (hardwire, 0.06-ohm, 0.2-ohm, or as required) across the track at the receiver track connections of the approach. When the ballast is poor, connect the shunt across the track at a point 30 ft. (9.14 m) beyond the receiver track connections of the approach. Ensure that the shunt has solid connections to each rail.
Step 2	From the System View menu, select the PSO to calibrate, i.e., 2 – 6 by entering that number on the keypad. The menu shows only enabled tracks and/or PSOs.
Step 3	From the PSO “N” Options menu, select 3) Calibration . The PSO “N” Window appears, depicting the Calibration status of: 1) RX1 , along with Code and Signal Level values 2) RX2 , along with Code and Signal Level values 3) Island , along with Island Status light and Z Level values 4) If Calib Required appears on any of the above lines, calibration is required.
Step 4	Either select the 1) RX1 line If the application is an Internal PSO, or select the 2) RX2 line If the application is a Center Fed PSO
Step 5	Select Start. Calibration begins.

Table 16: PSO Module Calibration

 WARNING	
<p>IF “FAIL” APPEARS ON THE DISPLAY, THE CALIBRATION REQUIRED LED (LEFT COLUMN) REMAINS LIT, OR THE CALIBRATED LED (RIGHT COLUMN) DOES NOT LIGHT, THE CALIBRATION PROCESS DID NOT COMPLETE. SHOULD THIS HAPPEN, CYCLE THE UNIT POWER AND THEN REPEAT STEP 2 ABOVE. IF “FAIL” APPEARS AGAIN, FURTHER TROUBLESHOOTING IS REQUIRED.</p>	
<ul style="list-style-type: none"> • THE FREQUENCY AND/OR ADDRESS DOES NOT MATCH BETWEEN THE TRANSMITTING AND RECEIVING UNITS. • THE TRANSMIT SIGNAL IS NOT BEING RECEIVED (THIS CAN BE CAUSED BY EITHER AN OPEN TRACK CONNECTION OR THE TRANSMITTER UNIT NOT PHYSICALLY TRANSMITTING DUE TO THE TRANSMIT ENABLE INPUT NOT BEING ENERGIZED). 	
<p>Step 6</p>	<p>Remove the track test shunt. The Occupancy LED should light. If the Occupancy LED fails to light, the calibration process has failed (refer to the WARNING above). Inspect all equipment and connections. Check Receive Value. If value is 90, then the PSO was calibrated with bad test shunt. Repeat steps 1 – 6. If the calibration fails again, further troubleshooting is required.</p>

 **WARNING**

VERIFY THAT THE PSO MODULE’S SOFTWARE, FREQUENCY, AND ADDRESS FORMATS ARE AS SPECIFIED BY THE RAILROAD’S OR AGENCY’S APPROVED WIRING OR INSTALLATION DIAGRAM. FAILURE TO DO SO MAY LEAD TO INCORRECT OR UNSAFE OPERATION OF THE TRACK CIRCUIT.

IF ANY RECEIVER IS CALIBRATED IN POOR BALLAST CONDITIONS, IT MUST BE RE-CALIBRATED WHEN BALLAST CONDITIONS IMPROVE.

FAILURE TO FOLLOW THE RAILROAD’S OR AGENCY’S

APPROVED WIRING OR INSTALLATION GUIDELINES REGARDING RECEIVER SETTINGS AND CALIBRATION MAY LEAD TO POSSIBLE UNSAFE OPERATION OF THE TRACK CIRCUIT.

AFTER CALIBRATION, VERIFY THAT THE TRACK CIRCUIT DE-ENERGIZES WHEN THE TRACK CIRCUIT IS SHUNTED WITH THE APPROPRIATE CALIBRATION RESISTANCE (0.06, 0.2, 0.3, 0.4, OR 0.5 OHMS). FAILURE TO DO SO MAY LEAD TO INCORRECT OR UNSAFE OPERATION OF THE TRACK CIRCUIT.

FOLLOWING INSTALLATION OR AFTER ANY RECEIVER MENU CHANGES HAVE BEEN MADE, RECALIBRATE THE RECEIVER AND TEST FOR PROPER OPERATION PER THE REQUIREMENTS SPECIFIED IN TABLE 2 AND TABLE 4.

PSO Module Checkout Procedures

Table 17: PSO Module Calibration

Step 1	Scroll to System View, select track number which will bring up Track Options Menu. Select 1) Detail View, then select 5) for PSO Module Details.
Step 2	Take note of the Signal Level. This is the normal receive signal value.
Step 3	In the shelter containing the transmitter, remove the transmitter's signal to the track by disconnecting a transmitter lead from the shelter's track surge equipment.
Step 4	On the receiver, take note of the Signal Level. If the Signal Level is greater than 20, an unassociated signal of like frequency may be present.
<div data-bbox="716 1419 906 1461" data-label="Image"> </div> <p>THE CONDITION DETERMINED IN STEP 4 MUST BE RESOLVED. DO NOT PROCEED TO STEP 6 AND BEYOND UNTIL THE UNASSOCIATED SIGNAL OF LIKE FREQUENCY IS NO LONGER PRESENT.</p>	
Step 5	Verify that the RX LED found in the Occupancy portion of the face of the unit is de-energized.
Step 6	Restore the Transmitter signal to the track by reconnecting the lead in the transmitter's shelter track surge equipment.

Table 17: PSO Module Calibration

Step 7	Verify that the RX LED found in the Occupancy portion of the face of the unit energizes. If the LEDs fail to light, troubleshoot the unit, recalibrate, and perform Steps 1 – 6 again.
Step 8	Verify proper operation of the track circuit equipment before placing in service in accordance with railroad or agency procedures and applicable FRA rules.
Step 9	Verify proper PSO module operation by observing train moves, per railroad or agency policy.

TCN and FCN

The GCP 4000 provides a Track Check Number (TCN) for each track. The TCN provides a way for the Maintainer to know if any track calibration changes have been made since they recorded the TCN value. This check number changes whenever any of the following are performed:

- The main and standby track cards will have different TCNs as they are calibrated at different times.
- The main and standby will have different FCNs if any TCN changes or the SSCC lamp voltages are adjusted will cause the FCN to change. The Field Check Number (FCN) is a combination of all the track check numbers and the SSCC lamp voltage settings.

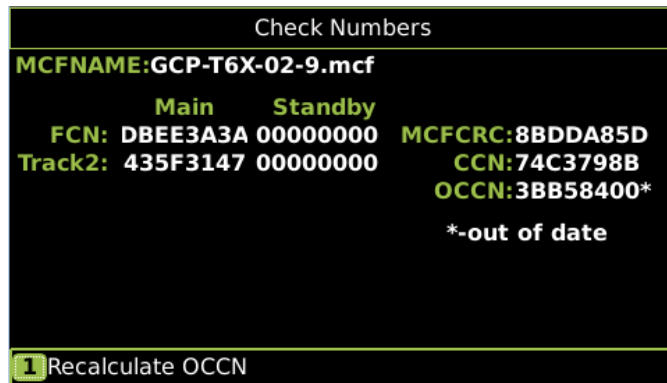

Figure 7 Check numbers Screen for GCP 4000

The TCN and FCN will show a value of 0 if the track card is not fully configured and calibrated and in session with the CPU (for the powered side).

If a parameter is changed which causes the GCP to require calibration, then the TCNs for both main and standby will show zero. When the main is then fully calibrated its values will be non-zero, the standby TCNs will still be at zero, thus providing an indication that the unpowered standby side has not yet been calibrated (see figure 9 above)

NOTE

If a parameter that affects the TCN is changed, so calibration is required, but then it is changed back to its original value, the GCP will no longer require calibration, but the TCN is updated to a new value, as the TCN is recalculated when the GCP goes from an uncalibrated to a calibrated state.

The FCN is an overall check number covering the TCNs for all used tracks and the crossing controller lamp voltage settings. It will also show 0 if any track is not calibrated. The configuration report lists the main and standby TCNs and FCNs.

NOTE

The main/standby TCNs and FCN, and OCCN out of date indication are only available on the Display if the Display Software version is later than 1.5.7r AND if the CPU II+ version after ncg05_30.mef or later or if the CPU III is used its version is 9VC72-V3H01_10.mef or later. The main/standby TCNs and FCN, and OCCN out of date indication are available on the CP Web IO for CP versions after 1.1.61r.

ADJUSTING LAMP VOLTAGES FOR SSCC IIIi

(When a “True RMS AC + DC” meter is not available)

General

WARNING

TO PREVENT AN OVER-VOLTAGE CONDITION AT THE LAMPS, USE A VOLTMETER WITH A “TRUE RMS AC + DC” SCALE AND MAKE ALL MEASUREMENTS USING THAT SCALE.

To accurately read the crossing lamp voltages, a “True RMS AC + DC” multimeter (e.g., Agilent U1252A digital multimeter or equivalent) is preferred, however, a conventional multimeter may be used, but the voltage reading will be lower than “True RMS AC + DC” values. The variance is not a set percentage and is dependent on battery voltage. A conversion table for several conventional meters is provided in the table below.

Table 18: Multimeter Reading Variance From Actual Incandescent Lamp Voltage

Battery Voltage	Regulated Lamp Drive Voltage Range	Measurement Below Actual Drive Voltage	
		Using Digital Multimeter (Not a True RMS AC + DC)	Using Analog Multimeter (TS111)
13.3	9.0 to 12.0	1.3 volts	0.6 volt
	>12.0	0.91 volt	0.42 volt
14.7	9.0 to 12.0	2.2 volts	1.1 volts
	>12.0	1.54 volts	0.77 volt
15.8	9.0 to 12.0	2.6 volts	2.0 volts
	>12.0	1.82 volts	1.4 volts

NOTE

The variance table applies to incandescent lamps and only LED lamps that present a resistive load to the SSCC IIIi. For other kinds of LED lamps, it is recommended that the voltage measured by a meter which is set to “True RMS AC + DC” be considered as correct.

Meter Reading Conversion Examples

Following are two examples of how to measure the lamp voltages using a conventional meter. In both examples:

- Battery bank voltage is 14.7 volts
- Multimeters are set to read DC

Lamp Voltage Measurement Example 1

When setting crossing lamp voltages to 9.5 volts, the conventional meter reading is determined by subtracting the meter variance given in Table 18 from the desired lamp voltage.

When using a **digital multimeter** (Not True RMS AC + DC):

- Desired lamp voltage = 9.5
- Meter variance for 14.7 volt battery = -2.2
- Meter reading = **7.3**

When using an **analog multimeter** (e.g. TS111):

- Desired lamp voltage = 9.5
- Meter variance for 14.7 volt battery = -1.1
- Meter reading = **8.4**

Lamp Voltage Measurement Example 2

In this example, it is desired to check that lamp voltage is greater than 8.5 volts and the battery voltage is 13.3 volts.

When verifying that the lamp voltages are greater than 8.5 VDC, the conventional meter reading is determined by subtracting the meter variance given in Table 18 from the minimum lamp voltage threshold.

When using a **digital multimeter** (Not True RMS AC + DC):

- Minimum lamp voltage threshold = 8.5
- Meter variance for 13.3 volt battery = -1.3
- Minimum meter reading = **7.2**

When using an **analog multimeter** (e.g. TS111):

- Minimum lamp voltage threshold = 8.5
- Meter variance for 13.3 volt battery = -0.6
- Minimum meter reading = **7.9**

SSCC IIIi LAMP VOLTAGE ADJUSTMENT

⚠ WARNING

TO BE ACCURATE, LAMP VOLTAGES MUST BE MEASURED AT THE LAMP. THE VOLTAGE ON THE DISPLAY IS THE VOLTAGE AT THE SSCC CONNECTOR. INACCURATE MEASUREMENTS MAY RESULT IN DIM LAMPS OR EARLY LAMP FAILURE.

NOTE

Before performing Lamp Voltage Adjustment procedure, the crossing controllers must be inactive, i.e., gates up, lights off and bell off. If a train approaches during lamp adjustment, the crossing controllers will activate and the lamps will flash. Restart Lamp Voltage Adjustment Procedure following completion of train move.

The regulated output is a pulse-width modulated output that produces a square wave. A “True RMS AC + DC” meter is required to accurately measure the voltage See Table 18 when using a conventional meter.

If SSCC IIIi modules are included in the system, proceed to **SSCC IIIi LAMP VOLTAGE ADJUSTMENT** and **SSCC LAMP TESTS**. Otherwise, proceed to **OPERATIONAL CHECKS**. Regardless of the actual location of the SSCC IIIi board on the physical case of the GCP, the tabs on the Lamp Setup Window depicts the two choices as Slot 8 SSCC IIIi and Slot 9 SSCC IIIi.

When “far gate” lamps and “near gate” lamps are driven from the same output, first adjust the lamp voltage on the far gate. Then adjust the lamp voltage on the near gate using adjustment resistors.

On the Lamp Setup screen dV indicates tenths of a volt (decivolt). 100 dV is equal to 10.0 volts.

**Table 19:
Crossing Controller Lamp Voltage Adjustments**

Step 1	From the System View menu, select the number that appears to the left of the SSCC line at the bottom of the screen. <ul style="list-style-type: none">• The SSCC Menu appears
Step 2	Select 1) Lamp Adjust <ul style="list-style-type: none">• The SSCC/SL8 window appears

**Table 19:
Crossing Controller Lamp Voltage Adjustments**

Step 3	<p>Select the Lamp 1 Voltage value by pressing ENTER.</p> <ul style="list-style-type: none"> • The illustration of the gate appears with a white background and depicts Lamp 1 as lit. • Lamp 1: reports On • The Set Voltage tile opens.
Step 4	<p>Set the Lamp 1 Voltage field to the output voltage required to set the correct voltage at the lamps.</p> <ul style="list-style-type: none"> • Select the voltage by either: <ul style="list-style-type: none"> • Scrolling to the desired voltage reading in 1 dV (0.1 V) steps by using the up or down arrows on the keypad or • Enter the numeric value using the keypad. • Measure voltage at the actual lamps.
Step 5	<p>When the meter displays the correct voltage, select the Enter button.</p> <ul style="list-style-type: none"> • The new voltage value is saved. • Lamp 1: reports Off • Corresponding lamp output is turned off. • The Lamp 2 Voltage value is highlighted
Step 6	<p>Select the ENTER. The Set Voltage tile opens.</p> <ul style="list-style-type: none"> • The illustration of the gate continues to appear with a white background and now depicts Lamp 2 as lit. • Lamp 2: reports On • Corresponding lamp output is turned on.
Step 7	<p>Set the Lamp 2 Voltage field to the output voltage required to set the correct voltage at the lamps.</p> <ul style="list-style-type: none"> • Select the voltage by either: <ul style="list-style-type: none"> • Scrolling to the desired voltage reading in 1 dV (0.1 V) steps by using the up or down arrows on the keypad or • Enter the numeric value using the keypad. • Measure voltage at the actual lamps.
Step 8	<p>When your meter reads the correct voltage, select the Enter button</p> <ul style="list-style-type: none"> • The Lamp 2 Voltage field deactivates. • Lamp2: reports Off • The new voltage value is saved. • Corresponding lamp output is turned off.
Step 9	<p>Select the SSCC/SL9 by scrolling using the right or left arrows.</p>
Step 10	<p>Repeat steps 3 through 8 for the second SSCC Illi module.</p>

OPERATIONAL CHECKS

SSCC IIII TEST MODE

WARNING

THE SSCC TEST MODE WILL NOT PREEMPT TRAFFIC SIGNALS. VERIFY THAT VEHICLES ARE CLEAR OF THE WARNING DEVICES BEFORE ACTIVATING THE SIGNALS.

NOTE

While in Test Mode, if a train approaches (XR input logic de-energizes), the test is cancelled and the crossing activates normally. When the train departs, the system remains in normal operation.

Table 20: Crossing Controller Lamp Test Selection

Step 1	From the System View menu, select the number that appears to the left of the SSCC line at the bottom of the screen. <ul style="list-style-type: none">• The SSCC Menu appears
Step 2	Select 2) SSCC Test <ul style="list-style-type: none">• The SSCC/SL8 window appears

The operation of each Solid State Crossing Controller (SSCCIII) can be tested from this window.

Select the Crossing controller using the right or left arrow to scroll to either

- Slot 8 SSCC IIII
- Slot 9 SSCC IIII

The **SSCC/SL8 Menu** appears with the **Select Test** field highlighted. When the **ENTER** button is selected, the **SSCC Test** menu opens

SSCC TEST MENU

The following SSCC tests may be performed:

- **1) Bell:** Turn on the bell output
- **2) Lamp 1:** Turn on Lamp 1 output
- **3) Lamp 2:** Turn on Lamp 2 output
- **4) Flash the Lamps:** Test the lamp outputs on both controllers
- **5) Test the crossing:** Flash the lights, ring the bell, run the gate delay, and then drop the gate.
- **6) Perform a Timed Test**
- **7) Perform a Repeat Test**

Types of Tests

Timed Tests: When the Timed Test is started, the GCP performs the following sequence:

- pauses for the programmed **Lamp Test Delay** time
- flashes the lamps for the programmed **Lamp Test On** time
- turns the lamps off
- stops the test.

Repeat Tests: When the Repeat Test is started, the GCP performs the following sequence:

- pauses for the programmed Lamp Test Delay time
- flashes the lamps for the programmed Lamp Test On time
- turns the lamps off for twice the programmed Lamp Test Delay time
- flashes the lamps for the programmed Lamp Test On time
- turns the lamps off
- stops the test.

Parameters for Timed Tests

Parameters for each SSCC timed test are set in the fields below the **Select Test:** field.

The **Lamp Test On** field designates the duration of the Lamp On test.

Select the **Enter** button to the right of the field to open the **Lamp Test On (sec)** dialog box. This **Lamp Test On (sec)** dialog box allows the test duration timer to be modified.

- Default value: **15 sec**
- Valid entry range: **15 to 60** seconds

The **Lamp Test Delay** field designates the time between test selection and test start. Select the **ENTER** button to the right of the field to open the **Lamp Test Delay (sec)** dialog box. This **Lamp Test Delay (sec)** dialog box allows the **Lamp Test Delay** timer to be modified.

- Default value: **30 sec**
- Valid entry range: **30 to 120** seconds

The **Lamp Test Cancel** field designates the automatic test termination time following test initiation. Select the **ENTER** button to the right of the field to open the **Lamp Test Cancel (min)** dialog box. This the **Lamp Test Cancel (min)** dialog box allows the **Lamp Test Cancel** timer to be modified.

- Default value: **5 min**
- Valid entry range: **1 to 15** minutes

Test Status Indications

The status of the SSCC IIIi module appears in the gate display field at the bottom of the window during tests.

Four status notations appear during operational tests:

- **Off** indicates that the SSCC IIIi lamp drive outputs are off.
- **Ringing** indicates that the SSCC IIIi module bell output is energized.
- **Flashing** indicates that the SSCC IIIi module lamp outputs are alternately energizing (flashing).
- **Failed** indicates that a bell, lamp, or crossing gate output failure has been detected.

GCP OPERATIONAL TEST MODE

Prior to placing a system in service, tests must be performed to verify proper system operation and I/O wiring. Proceed to next step if a feature is not used.

WARNING

AFTER INITIAL PROGRAMMING OR PROGRAMMING, MODULE, TRACK, OR WIRING CHANGES, TESTS MUST BE PERFORMED TO VERIFY PROPER OPERATION OF THE GCP PRIOR TO PLACING A SYSTEM IN SERVICE.

WARNING

IF A RAPID CHANGE OCCURS IN THE VALUE OF EZ AT ANY TIME THE TRAIN IS MOVING WITHIN THE TERMINATION SHUNTS, TRACK DISCONTINUITY CAUSED BY A HIGH RESISTANCE BOND OR A DEFECTIVE COUPLER IS INDICATED. LOCATE AND CORRECT THE PROBLEM IMMEDIATELY.

THE RAILROAD PROCEDURES GOVERNING HOW TO TAKE A TRACK CIRCUIT OUT OF SERVICE SHALL BE FOLLOWED. THE INSTRUCTIONS IN THIS SECTION MAY BE FOLLOWED ONLY IF ALLOWED BY THE RAILROAD.

Table 21: GCP Operational Tests

Step 1	Check tracks for: <ul style="list-style-type: none">• Open transmit wire<ul style="list-style-type: none">• Crossing activates• EZ = 0• Open receive wire<ul style="list-style-type: none">• Crossing activates• EZ = 0
Step 2	UAX, DAX Enables & AND Enable input(s), if these features are used: <ul style="list-style-type: none">• Crossing activates when each remote DAX line circuit that controls a UAX, DAX Enable or AND Enable input (controlling the crossing) is de-energized or opened from the far end of the circuit.• Pickup Delay time is correct when input closes.
Step 3	DAX outputs and "Radio DAX" operation using Spread Spectrum Radio, if these features are used: <ul style="list-style-type: none">• Downstream crossing activates when the appropriate DAX output or Radio DAX message is deenergized• DAX Pickup Delay time is correct

Table 21: GCP Operational Tests

<p>Step 4</p>	<p>Wrap logic if this feature is used:</p> <ul style="list-style-type: none"> • Wrap logic W is displayed on Main status screen for each corresponding wrapped track (when Wrap inputs are energized as seen on system I/O view). <p>W is removed from corresponding track on Main status screen when:</p> <ul style="list-style-type: none"> • Corresponding track with wrap is shunted or • Corresponding wrap input is deenergized <p>Measure Wrap LOS pick-up delay from the time the wrap input is energized until the W is displayed on corresponding track status screen. Verify the LOS pickup delay time (minimum of 5 seconds).</p>
<p>Step 5</p>	<p>Override logic, if this feature is used. There may be one or up to three Override inputs used depending on Override programming. The Override options are: ALL PREDICTORS Override or DAX A, DAX B and DAX C Override.</p> <p>When corresponding Override input is energized, Override Input Status is GREEN on System I/O view.</p> <ul style="list-style-type: none"> • Observe that corresponding Override input changes to RED when: • Corresponding switch in GCP approach is reversed or • Corresponding signal field apparatus is changed from energized to deenergized or deenergized to energized depending on field signal logic for Override.
<p>Step 6</p>	<p>Traffic Signal Preemption, if this feature is used: The preempt output deenergizes:</p> <ul style="list-style-type: none"> • When the prime deenergizes for simultaneous preemption • At the programmed preemption warning time for advance preemption • The warning devices activate when the prime predictor predicts, or after the Advance Preempt Delay timer times out, whichever is sooner. Time should be equal to Adv Preemption timer value or shorter. <p>When used, Advance Preempt IP input open causes Preempt Output to de-energize and activates warning devices after the Advance Preempt Delay Timer times out. (Observe input on I/O view).</p> <p>When used, Preemption Health IP input open activates warning devices immediately (without advance preempt Delay time interval). (Observe input on I/O view).</p> <p>When used, Traffic Signal Health open initiates simultaneous preemption, rather than advance preemption, upon train detection.</p>

Table 21: GCP Operational Tests

Step 7	<p>Island detection</p> <p>When used, observe the ISLAND symbol on tracks on the Main Status display.</p> <ul style="list-style-type: none">• Place a 0.06 ohm shunt on island track wires• ISLAND symbol is GRAY• Observe island LED on track module as shunt is removed and while ISLAND Pickup Delay is timing <p>ISLAND LED is flashing</p> <ul style="list-style-type: none">• After the island pickup delay time expires on module and island LED is steady RED• ISLAND symbol on Main display is GREEN, and warning devices are deactivated.
Step 8	<p>Out of Service (OOS), if this feature is used:</p> <p>If the Display method is used:</p> <ul style="list-style-type: none">• Take each track out of service using the display.• Verify that the Display indicates track is OOS <p>Return track to service</p> <ul style="list-style-type: none">• Display indicates track is back in service <p>If Display + OOS IP input is used, then for each track:</p> <ul style="list-style-type: none">• Turn on OOS input for the track (observe input on I/O view).• Take track OOS using the display• Display indicates track is OOS• Turn off OOS input• Display indicates track is back in service <p>If OOS IP Input is used:</p> <ul style="list-style-type: none">• Turn on OOS input for the track (observe input on I/O view).• Main Display indicates track is OOS• Turn off OOS input• Display indicates track is back in service <p>If 4000 Case OOS IP Input used:</p> <ul style="list-style-type: none">• Turn on 4000 Case OOS input. (observe input on I/O view).• Main Display indicates all track are OOS• Turn off 4000 Case OOS input• Main Display indicates all tracks are back in service

Table 21: GCP Operational Tests

Step 9	Maintenance Call (MC) Light, if this feature is used: <ul style="list-style-type: none">• Verify that the light is illuminated• Verify that the MC goes dark when one of the following occurs:<ul style="list-style-type: none">○ Taking a track out of service, or by energizing an out-of-service input.○ If “Low Battery Enable” is ON, temporarily raise the “Low Battery Level” setting to above the battery voltage.○ Removing CPU module from the chassis, which will activate the crossing also. Restore the track, low battery level, or CPU module to operation and the MC light should turn off.
Step 10	If Positive Start, Advanced Approach Prediction, and/or Sudden Shunt Detection are used: <ul style="list-style-type: none">• Shunt at the appropriate point• Take the required measurements• Reprogram EZ threshold levels as required

Finishing Step 9 or, if required, Step 10 completes the GCP operational checks / tests. Proceed to SSCC IIIi Operational Tests for SSCC calibration and operational checks / tests.

SSCC IIIi OPERATIONAL TESTS

After the system has been programmed, GCP calibrated and the lamp voltages have been adjusted, tests must be performed to verify the operation of the SSCC prior to placing the system in service. In addition to the operational tests required by the maintaining railroad, the SSCC operation should be further tested and verified as described in the SSCC Operational Tests procedure provided below.

⚠ WARNING

AFTER INITIAL PROGRAMMING OR PROGRAMMING, MODULE, OR WIRING CHANGES, TESTS MUST BE PERFORMED TO VERIFY PROPER OPERATION OF THE SSCC PRIOR TO PLACING THE SYSTEM IN SERVICE.

NOTE

While in Test Mode, if a train approaches (XR input logic de-energizes, the test is cancelled and the crossing activates normally. When the train departs, the system remains in normal operation.

If advance preemption is used, the preemption output and warning devices will operate as follows for the indicated method of activation:

- For a train move:
 - Preemption Output de-energizes at the preempt warning time.
 - Activation of the warning devices will be delayed until the Advance Preempt Timer times out, or the Prime Warning time is reached.
- Advance Preempt Input de-energized:
 - Preemption Output de-energizes
 - Activation of the warning devices will be delayed until the Advance Preempt Timer times out.
- AND 1 Enable Input de-energized:
 - Preemption Output de-energizes
 - Activation of the warning devices occurs simultaneously (no advance preempt time).
- "Test the Crossing" Test Mode;
 - Preemption Output de-energizes
 - Activation of the warning devices occurs simultaneously (no advance preempt time).

Table 22: SSCC Operational Tests

Step 1	Verify that the light/gate battery is charged.
Step 2	Verify that all connectors on the SSCC have been properly positioned, seated and secured.
Step 3	Verify that all the electrical connections in the Bell, Lamp, and Gate circuits are properly assembled, tightened and secured.
Step 4	Verify that all flashing lamps light and none are burned out.
Step 5	Verify that all lights have been aligned.
Step 6	Verify that the gates are properly adjusted and operational.
Step 7	Verify that the bells are operational.
Step 8	Verify that all SSCC programming is correct (program and configure menus).
Step 9	Verify that all lamp voltages have been set.
Step 10	Momentarily turn on the flashers from the TEST menu and verify that the battery charger is operational and providing current to the lamps and battery.
Step 11	Verify that the gate delay time is correct.
Step 12	Verify that the lights continue to flash while the gates are rising.

After performing SSCC Lamp Mode Tests, GCP Operational Tests, and SSCC Operational Tests, verify proper Train Detection, Warning Times and Crossing Operation.

Table 23: Train Detection, Warning Times and Crossing Operation

Step 1	<p>EZ continuity check on train moves:</p> <ul style="list-style-type: none"> • Crossing devices activate and EZ value decreases smoothly (without rapid change) for an approaching train. • Crossing devices turn off when island recovers after train move and the EZ rises smoothly (without rapid change) as the train recedes.
Step 2	For MAIN and STANDBY, check warning times for inbound train moves on each approach including DAX operation.
Step 3	Check for proper gate / flasher / bell operation on all train moves.

SEAR Ili SETUP

Review the program in the GCP 4000 by using the left or right arrows and scrolling to the Program View screen, then scrolling down to or selecting option 2 to open the SEAR Programming menu.

NOTE

The SEAR interface may be accessed only from the A80485-1 Display and not on the PC based DT.

Refer to SEAR Ili Configuration Summary document for details of application CDL program, LEDs, and Alarms. ATCS address must be entered prior to SEAR Ili communicating with GCP

Prior to beginning SEAR Ili setup procedure have circuit plans showing SEAR Ili setup page available for reference.

Site Setup must be run in its entirety directly from the SEAR Interface on the GCP 4000 Display. Filling in certain fields via laptop and other interfaces does not accomplish setup and cannot be substituted for Site Setup.

STEP 1:

Select SEAR Programming on Program View screen.

- Step through the 3 stages of site setup by answering each question as indicated by the SEAR Ili setup page in the crossing's circuit plans.
 - Stage 1 will cover Date/Time, Site Identification Information, addressing, and serial port configuration. Refer to circuit plans for the specific answers such as ATCS address assignments. If plans do not have proper ATCS addresses, some portions of configuration cannot be completed.
 - Press **ENTER** to accept each step, or after revising each step.
 - Each stage will automatically compile when the end of the stage is reached.

- After stage 3 has compiled, the user will be prompted to install peripheral equipment on the Echelon® network. (This step assigns the ATCS subnode address of each device)
- This may include VHF communicators, iLODs, Analog/Digital I/O units, etc. If a Wayside Access Gateway (WAG) is used for communication protocol conversion, the WAG will be setup separately.
- When prompted, push the Echelon® service button on the side of each device and watch for “installed” to be shown on the display.
 - The button only needs to be depressed for approximately a second. The yellow LED next to the button will turn on during that time.

STEP 2:

The next step in the site setup process is battery calibrations.

- At this point, the user will be prompted to turn off AC power and select **ENTER**.
- The batteries will settle for 3 minutes.
- The voltage of each battery channel is shown and the user will press **ENTER** for each if the voltages are correct.
- Then, a prompt will instruct to turn AC power back on.

STEP 3:

The last step is lamp calibration.

- The first calibration requires AC to be on.
- Activate the warning devices by opening the AND 1XR input or by disconnecting the GC/Bell WAGO connector for a SSCC Illi module.
 - This step requires that the SEAR Interface screen be displayed
 - Once the gates are horizontal (gate tip sensors on), press “enter”.
 - After 15 seconds the user is asked how many bulbs are on each sensor, if the correct amount is not shown, enter that value, when the correct number is shown press **ENTER**.

Next, the SEAR Ili will prompt for the same calibration steps but with AC power off.

WAG NODE INSTALLATION

If a Wayside Access Gateway, WAG, is used as a protocol converter to Internet protocol, it will need to be installed as a module to the SEAR Ili.

From the A80485-1 keypad, select **0 Main Menu**.

- Press **down arrow** until you come to **CONFIGURATION**.
 - Press **ENTER** on the keypad to select it.
- Press **down arrow** until you come to **MODULES**.
- Press **ENTER** on the keypad to select it.
- **ADD MODULE** will be the first menu item displayed.
- Press **ENTER** to select it.
- The screen will read **MODULE TYPE**.
 - Press the Down Arrow key until **WAG** appears.
 - Press **ENTER** to Select it.
 - Use the number/letter keys on the keypad to spell the Module Name. (Similar to the way you add a name on a cell phone.)
 - Press **ENTER** to enter the name you typed.

- Refer to site plans and enter proper NODE assignment.
 - Set NODE to 1, if assignment is not on plans.
 - You will be returned to **MODULE MENU** at the **ADD MODULE** prompt.
 - Press **EXIT** to return to the **CONFIGURATION** at the **MODULES** prompt.
 - Press **EXIT** again.
 - You will be prompted with **SAVE CONFIGURATION CHANGES? YES**. (You can press the UP or DOWN arrow to scroll between YES and NO.)
 - Press **ENTER** to select **YES**.
 - The unit will recompile and save the changes.
- Ensure the AUX Serial Port is set to the baud rate shown on circuit plans.

SEAR Ili OPERATION

Now that site setup is complete, peripheral devices, as well as items onboard the SEAR Ili will be checked for proper operation. This ensures that the SEAR Ili is receiving all the information it needs for proper alarming and execution of the SEAR Application Program. Unless specified, all items below will be described assuming a laptop is present with a Terminal Emulator connection to the SEAR Ili's USER port. All items in this section can be done through similar menus from the GCP 4000 display module. Once Terminal Emulator is running, enter **CTRL+L** on the computer to initiate the communication session with the SEAR Ili.

The following screen will be displayed. To select a menu item, press the letter corresponding to the menu item.

All peripheral equipment on the Echelon® network will need to be checked for good communication with the SEAR Ili.

All of those modules can be checked in one screen by choosing, **Main>Monitor>Module Comm. status**.

The type of module will be shown on the left and the communication status will be on the right. The status of each module should be "GOOD".

Verify iLOD operation by the following:

- Once good communication is verified, further checks of the iLOD can verify that it is seeing normal amperage/flash rates.
- To view these values in real time, select **Main>Monitor>Module I/O>** and then choose the iLOD unit to view.
 - In that screen both sensors are shown, the first iLOD unit will show EB1, EN1. When the lamps are flashed, both sensors should display that lamps are on, the amperage reading, and the flash rate in flashes per minute.
 - These values are shown in real time; they should be steady and not fluctuate. If the value fluctuates, the lighting circuit will need to be checked for intermittent operation.
- Verify operation of Ground Fault Testers (GFTs):
 - All LEDs on the GFT units should be on steady. If the BAT 1 Fault or BAT 2 Fault LEDs are slow flashing then they have detected a ground condition.
 - The GFT can be monitored at **Menu>Monitor>Onboard I/O>** and then use the right arrow keys until the GFT input is displayed. If

the input shows STUCK LOW, that indicates the data wire between the GFT and SEAR Ili is open and will need to be repaired.

If the data connection is good, the following would be displayed for GFT1:

- GFT1: HL=G MD=N B1=0 B2=0
- HL=G indicates that the GFT health is good.
- MD=N indicates that test mode=no
- B1 & B2 = 0 shows that there are no ground faults on BAT 1 or BAT 2.
- A ground can be simulated on those inputs by running a wire from the ground input of the GFT to each BAT input, one at a time. The state of each BAT input will change to '1' if a ground is present.

Verify MTSS/gate tip/bell sensor:

- The MTSS can be monitored in the same screen as the GFT: **Menu>Monitor>Onboard I/O>**. As with the GFT, if the input shows STUCK LOW, then the data wire between the MTSS and SEAR Ili is open and will need to be repaired.

If the data connection is good, the following would be displayed for TSS1:

- TSS1: U=1 D=0 T=0 A=0 P=0
- U=Gate Up
- D=Gate Down
- T=Gate Tip Sensor
- A=Bell Audio
- P=Bell Power

NOTE

These items can be either 1 or 0. In the example, U=1 so the gate up contact is energized. The other items are all de-energized. Dropping the gates to horizontal will activate the tip sensors and deenergize the gate up contact, changing the MTSS data to U=0 and T=1. Activating the bell will check the bell sensor, A & P should both equal 1 when the bell is on.

The SEAR Ili relays must function properly in order to run automated inspection tests. These outputs are most easily tested using the SEAR menu on the GCP 4000 display module.

- Verify SEAR Ili relays:
 - Go to MENU > DIAG/MONITOR > RELAYS > GndFitTest and press ENTER.
 - Then press '1' to energize the relay output. Both BAT FAULT LEDs on the Ground Fault Testers should be flashing.
 - Now press '0' to deenergize the relay. The LEDs should go on steady.
 - Press EXIT and then ENTER to get back into the RELAYS menu.
 - Select AC Control. Press '1' to energize the relay output. AC power to the chargers should go off, or Press '0' to deenergize the relay and be sure that AC power to the chargers is restored.

Press "exit" until the date/time main screen is visible.

SEAR Ili Communication

Testing communications to the office can be accomplished using a menu function to generate a test alarm and by creating events that generate alarms. Before testing the SEAR Ili by sending alarms to the office, the unit must be configured for communications in the Site Setup. Once a SEAR Ili is configured thru Site Setup and communication established, the location will register itself with the WAMS office.

Test Communications with SEAR option on the display menu.

- In the SEAR Interface menu, select MENU.
 - Press the down arrow to DIAG/Monitor press ENTER
 - Press the down arrow to FIELD COMM, press ENTER. TX: waiting... RX: waiting will be displayed. (If site is to hop data to, or receive data from, another crossing. To send a test packet to the other crossing Press 4).
 - Enter ATCS address of the other crossing.
- To send a test packet to the WAMS office:
 - Press 5
 - Enter railroad specific office address.
 - Refer to circuit plans for office address.

Typically, the office ATCS address is 2.RRR.00.0000, where RRR is the ATCS number assigned to the railroad.

SEAR Ili Alarms

Alarm Generation is the final step in checking out the SEAR Ili/WAMS interface. The following procedure tests the wiring of the various components in the SEAR/ WAMS sub-system.

Ground Fault Alarm

- A ground fault can be simulated on those inputs by running a wire from the ground input of the GFT to each BAT input, one at a time.
- Each Battery's LED will flash when ground fault is detected and a "Ground Fault Detected on xxx" alarm will be generated where xxx represents the Battery name.

Ground Fault Clear

- Removing the wire that simulates the ground will generate a Ground Fault Cleared message.

Analyzer Failure Alarm

- Remove the connector that powers the GFT or that MTSS unit inside the gate mechanism. Doing so on either unit will cause an "Analyzer Failure" alarm.

Analyzer Normal



AT CROSSINGS USING MEFs XNG02_00.MEF AND EARLIER, GATES WILL BEGIN TO LOWER IMMEDIATELY (WITHOUT GATE DELAY TIME) WHEN THE TRANSFER SWITCH IS USED TO SWAP BETWEEN HEALTHY UNITS. USE CAUTION WHEN TRANSFERRING CONTROL TO AVOID GATES HITTING VEHICLES OR PEDESTRIANS.

GCP Transferred Alarm

- Force the GCP to switch to Standby by the transfer switch on the Transfer Module.
- This will create a GCP Transferred Alarm.
- Forcing it to switch back will cause another GCP Transferred message.

WARNING

TAKE ALTERNATE MEANS TO WARN VEHICULAR TRAFFIC, PEDESTRIANS AND EMPLOYEES. REMOVAL OF A SSCC IIIi WILL CAUSE THE GATES TO DESCEND IMMEDIATELY (WITHOUT GATE DELAY); HOWEVER, THE LIGHTS WILL NOT ACTIVATE.

TROUBLESHOOTING

The GCP Display is the main diagnostic tool available to maintenance personnel.

The EZ and EX are shown for each track. A track status area is displayed for each track module in the system (up to six). The approximate speed of a train approaching the crossing is shown as a positive (+) number. The approximate speed of a train moving away from the crossing is shown as negative (-) number.

NOTE

If the Display is replaced, the logs remain on the removed Display, and any logs stored on the new Display will be shown when called.

Whenever any files are being saved using the Display, they may be saved either to another computer or to a USB Device.

SYSTEM STATUS INDICATORS AND LOGS

Transfer Time Extension and Indication

The display module versions after 1.5.7r when used with CPU II+ version ncg05_40.mef /CPU III version 9VC72-V3H01_10.mef or later will show whether the main or standby side of a redundant GCP is powered and whether the CPU is driving the transfer output. On the local UI this shows as XFER icon which indicates main or stby. If the icon is grey the CPU is not driving the transfer output and if the switch on the transfer module is set to auto the transfer module will count down and switch power to the other side.



The screenshot shows a 'System View' screen with a table of track data and status indicators. The table has columns for Trk, EZ, EX, MPH, and ISL. Track 1 shows a red warning icon, EZ=1, EX=0, MPH=0, and ISL=Down. Track 2 shows a red warning icon, EZ=GCP, EX=Cal, MPH=Req, and ISL=CReq. At the bottom, there are status indicators: 'SSCC: 1 2' with red warning icons, an 'XR' button, and 'XFER: main' with a grey button.

Trk	EZ	EX	MPH	ISL
1	1	0	0	Down
2	GCP	Cal	Req	CReq

SSCC: 1 2 XR XFER: main

Figure 8 System Screen for GCP 4000 Transfer unhealthy

If the icon is green the CPU is driving the transfer output and the transfer module will not be counting down.

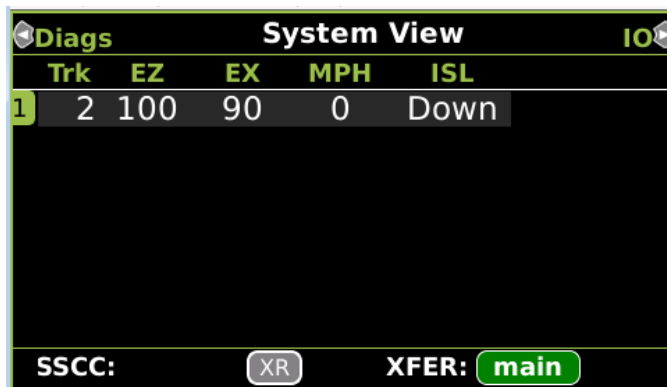

Figure 9 System Screen for GCP 4000 Transfer healthy

The GCP has a new feature (available in CPU software ncg05_40.mef or later) where the CPU will extend the transfer time by 5mins if it detects that it has the same problem on the main side as the standby side. This feature has been added so that in the case whether the transfer timer is set to a low value (2 or 3mins for example) the display has time to connect to the CPU and then provide time for the maintainer to take a track out of service if necessary. In this state the display module will show a yellow icon to indicate the transfer time has been extended. When the icon goes back to grey, the transfer timer on the transfer module will start counting down if the switch is in the auto position.



Figure 10 System Screen for GCP 4000 Transfer Extended

NOTE

The XFER icon is not shown on Display Software versions 1.5.7r or earlier or CPU III CP versions 1.1.61r or earlier, or new display software after 1.5.7r used with CPU II+ version ncg05_30.mef or earlier

The extended transfer feature will only with CPU II+ is version after ncg05_30.mef or CPU III versions after 9VC72-V3H01_10.mef or later.

The Web UI also shows the XFER icon in the same manner.

OCCN Log

The display module and CPU III provide a new log to aide in tracking down issues where the OCCNs do not match the current plan. This is primarily intended for use once the system is in service and in a maintenance mode. The new log easily allows parameters changed which have altered the OCCN to be seen.

NOTE

This is only available in the display module version with versions after 1.5.7r when used with CPU II+ versions later than ncg05_30.mef or CPU III versions later than 9VC72-V3H01_00.mef. And available in the CPU III with CP version later than 1.1.61r.

The log is cleared whenever the configuration is set to default, a new MCF loaded, or a PAC file loaded. The log is stored in the CIC on the chassis and so it will be retained even if CPUs or display modules are swapped out and provides a long-term history of OCCN parameter changes. The option is available on the Local UI on the Reports and Logs page

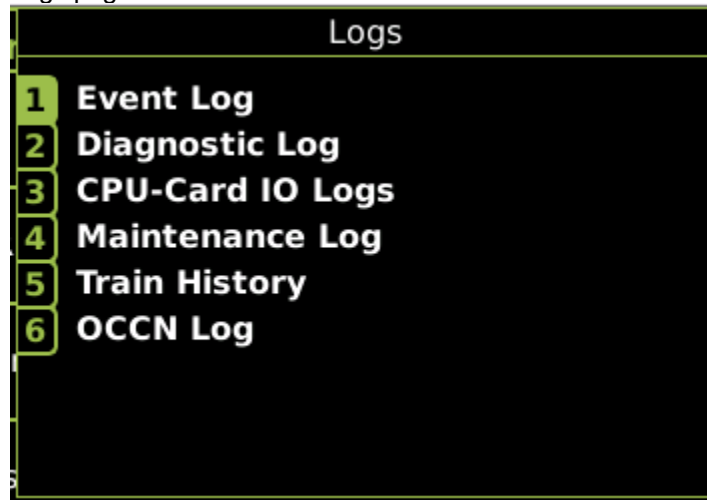

Figure 11 Log Options

In the GCP4000, the log will include an entry whenever an OCCN protected parameter changed, and whenever the user recalculated the OCCN from the display.



Time Stamp	Event Text
08-Jul-2020 17:28	OCCN Changed: 49DA1D6B
08-Jul-2020 16:44	Approach Distance 1001ft
08-Jul-2020	
08-Jul-2020 16:37	Module 7 Not Used
08-Jul-2020 16:36	Isl Frequency 4.9 kHz
08-Jul-2020 16:35	Approach Distance 1000ft
08-Jul-2020 16:35	GCP Frequency 285 Hz
08-Jul-2020 16:34	Module 1 Not Used
08-Jul-2020 16:29	Module 2 Track
08-Jul-2020 16:20	Defaults Set

Figure 12 Example OCCN Log

NOTE

The OCCN log is only available if the Display Software version is later than 1.5.7r and if the CPU II+ is used its version is later than ncg05_30.mef or if the CPU III is versions later than 9VC72-V3H01_00.mef.

Detail View Track Status Window Color Scheme

The status window background color indicates track status in Detail View:

- Red: The Track Module is not installed, or the Track Module is unhealthy
- Gray: The Track Module is healthy, and no train is in the approach
- White: The Track Module is healthy, and a Train is in the approach
- Flashing blue: The GCP or the island on the Track Module is out of service.

Track Function Status

The status of optional track functions is displayed at the end of each row depicting active tracks.

- Wrap Circuit Status
 - “W” indicates Wrap input energized.
 - “W” is displayed only when Wrap input is energized and when “Track # Wrap Used” is set to YES.
- Enhanced Detection
 - “ed” indicates enhanced detection has been activated for the current train movement.
 - “ed” is only displayed when “Enhanced Detection Used” is set to YES and inbound poor shunting is detected.
- Motion Sensor Restart
 - “m” indicates that the predictor switched to a motion sensor due to motion sensor control input being low or MS restart timer is running.

ISL and SSCC and System Status Indications

ISL:

- Gray symbol = island occupied
- Green symbol = island unoccupied or, if used, Wrap input energized regardless of occupancy state.
- No symbol = not used

AND:

- Status Bar indicates which AND functions are programmed as shown by a colored block depicting either XR or a number.
- Gray block = the AND function is de-energized and not Wrapped (if used).
- Green block = the AND function is energized and not Wrapped (if used).
- Yellow block = the AND function is Wrapped regardless of state of AND function logic.
- Flashing blue background = the AND functions are out of service. Reference Step 8 of Table 21 for 4000 Case OOS which will take AND functions out of service.

SSCC:

- Status bar Indicates which SSCC IIIi are used as shown by circled number.
 - Green block = not activated (lamps not flashing)
 - Grey circle = signals are activated (lamps flashing)
 - Red circle = signals are activated (lamps flashing)
 - Number not visible = not used

System:

- No Red DIAG triangle on top row = all tracks are calibrated
 - track conditions are within normal operating parameters
 - system is fully functional
 - Red DIAG triangle on top row = unhealthy system or track condition exists.
 - displays system status
 - status window for affected track also displays red
- Additional information is obtained by selecting the item number, which opens the Track “N” Options window and selecting 1) DETAIL VIEW. The Module Details window opens.
- The 2) ALARMS, 3) CALIBRATION, 4) REMOTE SETUP and 5) OUT OF SERVICE menus are also available when the track section is selected in the main status window.

NOTE

The recorder speed information is intended solely as a maintenance tool.

The train speeds are relative and may be affected by track parameters that include:

- Insulated joint proximity
- Insulated joint couplers
- Overlapping termination shunts
- Lumped ballast loads

The speed values are only intended to assist maintenance personnel in:

- Identifying slow versus fast train movements
- Distinguishing between accelerating, decelerating, and relatively constant speed train movements

The primary function of the recording is to document warning time.

Speed values are secondary and may not be consistent with recordings made by devices specifically designed to record train speed.

History Logs

NOTE

If the Display is replaced, the logs remain on the removed Display, and any logs stored on the new Display will be shown when called.

Four history logs may be accessed as shown below:

Train Log

Separate log for Main and Standby, with all Logs stored on the Display.

Each Log contains:

- Date and time of move
- Crossing warning time (**WT**)
- Detection (**Det**) speed
- Island (**Isl**) speed

Each move listing is designated by either an **X** (crossing) or **T** (track) to the right of the time entry.

Selecting the **ONLY** button selects only the crossing moves for display.

Select a train move entry and then the **VIEW** button to display the Train Move History Detail screen which includes:

- Average speed of the train move
- Route of the train move which is useful when multiple track circuits are used.

Maintenance Log

- Combines entries for both Main and Standby
- Maintenance Log is stored on the system.
- Information from Main and Standby CPUs stored in same log.
- Contains programming changes
- Contains Calibration information
- Contains user entered maintenance notes (ADD LOG ENTRY). For instance, Maintainer can add notes about weather, periodic tests, or reason for calibration.
- Can be cleared by maintainer after review.

NOTE

The Status Log and Summary Log show fewer events per screen when viewed on the GCP 4000 Display than on the WebUI.

Status Log

- Separate log for Main and Standby
- Status Log stored on CPU Module
- Main log on main CPU
- Standby log on standby CPU
- Contains all system events

Summary Log

- Provides a summary of the significant events from the status log.
- Separate log for Main and Standby (log is stored on the CPU)
- Contains error events.
- Can be cleared by maintainer after review

SYSTEM TROUBLESHOOTING

This subsection describes the method of troubleshooting a problem in a system that has previously been in service. The first step in troubleshooting a problem is to determine whether the components of a 4000 GCP system have detected a problem. When the 4000 GCP system is healthy, it shows the following:

- Track status line text is gray (or white if a train has been detected) on the Display.
- System Status bar on Status Screen is green.
- Health LEDs on all modules (CPU, Track, RIO, and SSCC IIIi) are flashing slowly (1HZ).
- Transfer Module display is not counting down.
- SEAR Alarm LED's indicate that no alarms are present.
- CPU LED 1 is lit, indicating that the Maintenance Call output is on.
- CPU LED 2 is lit, indicating that the transfer signal is being generated.
- Power LEDs on all modules are on and steady.

If the system has detected a problem, use the System Diagnostics or the Track Diagnostics to locate the problem.

Diagnostics

Each module also has diagnostic LEDs, and may have a four-character display, that assists in setup, calibration, diagnostics and troubleshooting. Refer to the Table of Contents at the front of this handbook to locate the exact Module required for LED and four-character display information.

When an unhealthy system or track condition exists, the System status bar is displayed red. The status window for the affected track module will also be displayed red as shown below.

System Diagnostics

System Diagnostics Window can be accessed in two ways:

- Select the track by pressing the requisite button, then select **2) Alarms**. The DIAG screen opens.
- Scroll to the **ALARMS** top level menu, then select **1) DIAG**. The DIAG screen opens, displaying any errors.
 - Selecting one of the displayed error descriptions displays the diagnostic detail screen shown on the following page.

This screen lists the cause and remedies for the selected error. Use the UP and DOWN buttons as needed to view all of the data.

Troubleshooting the Modules

The normal sequence of messages seen on the four character display when a CPU III is booting up is shown below:

```
CPU3 > Boot > Init > E087 > ICHK > CP MEF > VLP MEF >
GCP 4k MCF
```

If a CPU III is inserted into a system that does not have the MCF loaded it will need to load the MCF from the ECD, in this case the boot up message sequence is shown below:

CPU3 > Boot > Init > E087 > ICHK > CRC UCFG > NRBT
> Loading MCF > Burning MCF > DONE > Boot > IP :
Laptop > Init > ICHK > CP MEF > VLP ME > GCP 4k MCF

Note the E087 may or may not be present in the sequence above.

If the CPU III has been unpowered for more than a week and then it is inserted into a system, the boot up sequence may show the following:

CPU3 > Boot > Init > E087 > ICHK > CRC.. UCFG.. ERR
..ECD

In this case, leave the CPU III installed in the system with power on for 1 minute, then remove the CPU III module and reinsert it and it should boot up normally showing one of the first two sequences shown above.

Use the following tables to troubleshoot the individual modules.

Table 24: Diagnosing CPU Module Problems

Diag Display/ Description	Cause	Remedy
ADR ATCS Session address invalid (Diag3015) The radio DAXing neighbor ATCS address is invalid.	Usually occurs when ATCS Site Address (SIN) is not entered correctly	Reenter ATCS Site Address (SIN)
CAP MCF Capability Error (Diag3016) / The CPU is not capable of running this MCF	Usually occurs when using a recent MCF on an old CPU	Purchase a CPU with a higher capability or obtain an MCF requiring lower capability CPU
CCN CCN Incorrect (Diag3021) / The CCN is incorrect for the configuration.	After loading a configuration file, the CCN is incorrect.	Reload the configuration file and repower the CPU card. If error continues, perform Set to Default and reprogram the unit.
SEAR Health (Diag3021) / SEAR not in session	The SEAR Ili is selected as used but is not in session with the CPU	Check the ATCS addressing of the two units are correct. If the addresses are correct replace the SEAR Ili.
CIC CIC Access Error (Diag3022) / CPU unable to access data stored in CIC	If CIC access error is on MAIN CPU	<ol style="list-style-type: none"> 1. Remove Standby CPU and repower unit. 2. If CIC error clears, the Standby CPU is bad; replace bad card. 3. If error does not clear, remove Main CPU, return Standby CPU to original slot, and switch to Standby. 4. If error clears, MAIN CPU is bad; replace card. 5. If error does not clear, CIC is bad; replace GCP chassis.

Table 24: Diagnosing CPU Module Problems

Diag Display/ Description	Cause	Remedy
	If CIC access error is on STANDBY CPU Card	1. Remove Main CPU and repower unit. 2. If CIC error clears, the Main CPU is bad; replace bad card. 3. If error does not clear, remove Standby CPU, return Main CPU to original slot, and switch to Main. 4. If error clears, Standby CPU is bad; replace card. 5. If error does not clear, CIC is bad; replace GCP chassis.
CRC MCF/MEF CRC Incorrect / The MCF/MEF CRC is incorrect for the current MCF	MCF CRC entered is incorrect (Diag 3004)	Re-enter MCF CRC.
	MCF is corrupt (Diag 3003)	Reload the MCF.
	The executive (MEF) file is corrupt. (Diag 3014)	Reload the MEF.
CRPT MCF Checksum Incorrect (Diag3003) / The MCF did not load correctly.	The MCF is corrupt	Reload MCF
DFT Default Values set (DIAG3001) / Operating parameters have been set to default.	New MCF has been loaded	Set the operating parameters to the required values
DFT Vital Cfg Parm set to default (DIAG3002) / Vital Cfg parameters have been set to default.	New MCF has been loaded	Set the Vital Cfg parameters to the required values

Table 24: Diagnosing CPU Module Problems

Diag Display/ Description	Cause	Remedy
<p>DFT Configuration set to default (DIAG3017) / Configuration set to default.</p>	<p>The configuration parameters have been set back to default due to either:</p> <ul style="list-style-type: none"> • MCF change • Template change • User setting default 	<p>Wait. The error will clear itself.</p>
<p>INIT No VLP Comms (DIAG3020) / The VLP/CP LED on the CPU card does not light</p>	<p>The VLP is rebooting or is in its Initial State and performing its initial checks. This may occur after a VLP reset, or after changing templates.</p>	<p>Wait for a minute for the VLP to power up. If the VLP does not power up, check to see if it is continuously rebooting by checking the VLP Health LED.</p>
<p>MCF MCF Checks failed (DIAG3005) / Verification of MCF data failed.</p>	<p>The MCF is invalid.</p>	<p>Obtain and load a valid MCF.</p>
<p>MCF MCF Compatibility incorrect (DIAG3013) / MCF and MEF are incompatible</p>	<p>The installed MCF is incompatible with the MEF software</p>	<p>Obtain compatible MCF or MEF software</p>
<p>MCF Incompatible SEAR / MCF Combination (DIAG6001) / MCF and SEAR MEF are incompatible</p>	<p>The GCP MCF loaded is not compatible with the SEAR Executive.</p>	<p>Load the 9V725 SEAR Executive or a newer MCF.</p>
<p>MOD Module Type Error (DIAG3006) / The MEF software is incompatible with the module hardware.</p>	<p>The MEF is incompatible with this hardware.</p>	<p>Reload a valid MEF for this hardware.</p>

Table 24: Diagnosing CPU Module Problems

Diag Display/ Description	Cause	Remedy
UCFG VLP Unconfigured (Diag3018) / VLP is unconfigured and not communicating with I/O modules	Usually due to: <ul style="list-style-type: none"> • Incorrect MCF CRC. • MCF not loaded • MCF not stored in ECD (ECD replaced). • No ATCS Site ID (SIN) entered for radio DAX application 	Check other diagnostic message for exact cause.

Table 25: Track Module Indications (Module States)

Indication	Meaning	Module State
CHK1	The receive wire EZ reading is very low in comparison with the check wire EZ	All predictors are de-energized
CHK2	The check wire EZ reading is very low in comparison with the receive wire EZ	All predictors are de-energized
CHK3	The receiver and check wires have low reading (train at EZ=0), but island is not occupied. (Only shows when GCP and Island share same pair of transmit wires).	All predictors are de-energized
CHK4	The check wire and receive wire readings are more than 50 points different	All predictors are de-energized
CKEX	The check wire phase is incorrect	All predictors are de-energized
GAPP	GCP Approach Calibration is required	All predictors are de-energized
GCAL	GCP Calibration is required	All predictors are de-energized
GEXP	GCP detected decreasing phase which could be a bad bond	All predictors are de-energized
GFRQ	GCP frequency not set	All predictors are de-energized
GHWR	GCP hardware error	All predictors are de-energized
GIPS	Enhanced detection is turned on and the GCP detects poor shunting	Prime and Preempt de-energized (any zero offset predictors)

Table 25: Track Module Indications (Module States)

Indication	Meaning	Module State
GLCK	EZ or check EZ is below 3 after GCP has booted up Refer to the Troubleshooting section	All predictors are de-energized
GLIN	GCP Linearization Calibration is required	All predictors are de-energized
GOFS	MS/GCP Operation is Out of Service	All used predictors are energized All unused predictors are de-energized
GPRM	The Track Module is configured to expect an island and the prime has a non-zero offset value Set the prime to zero offset, if applicable If island is used at remote location, use a DAX not the prime Set the Island Connection to No Islands if no island is intended	All predictors are de-energized
GPSO	PSO UAX down after PSO fail timer expires or a train is stopped on the track.	All predictors are de-energized
GRCV	GCP receiver error	All predictors are de-energized
GSLV	GCP slaving error	No effect on predictors
GSTB	GCP is stabilizing after transmitter was turned on	All predictors are de-energized
GXMT	GCP transmitter error	All predictors are de-energized
HIEZ	High EZ (>115) detected on main or check wires	All predictors are de-energized
ICAL	Island Calibration is required	Island is de-energized
ICON	Island Connect Error. The GCP Island Connection indicates an island is connected, but no island is turned on.	All predictors are de-energized
IFRQ	Island frequency not set	Island is de-energized
IOFS	Island Operation is Out of Service	Island energized
ISTB	Island is stabilizing after transmitter has been turned on	Island deenergizes
IXMT	Island transmitter error.	Island deenergizes
LWEX	Low EX detected Low EX Adjustment is usually 39	All predictors are de-energized

Table 25: Track Module Indications (Module States)

Indication	Meaning	Module State
LWEZ	Low EZ detection is turned on and EZ has remained below the low detection level for longer than the low EZ detection time.	All predictors are de-energized
RECV (Recovery)	The GCP is running a 30 second Recovery Time-out after an error has cleared.	All predictors are de-energized
RECV (Recovery)	The Island is running a 30 second Recovery Time-out after an error has cleared.	Island is occupied
RXEX	The receive wire phase is incorrect	All predictors are de-energized
UCFG	Track module is unconfigured	All predictors are de-energized; Island is deenergized. Outputs are deenergized; Inputs are de-energized
VOER OUT	Output hardware failure detected. Output is commanded on but is detected as off	Failed output(s) de-energized

Table 26: Track Module Indications (Remedies)

Panel Indication – Diagnosis	Description	Cause	Remedy
CHK1 Gain Check – Receive Wire Error (Diag1008)	Receive signal level is low while check signal level is normal. Check EZ is normal and track EZ is very low value	High resistance or open connection in a receive wire.	Locate and repair open connection in the receive wires.
CHK2 Gain Check – Check Wire Error (Diag1007)	Check signal level is low while transmit and receive levels are normal. Check EZ is very low while track EZ is normal value	High resistance or open connection in a check wire.	Locate and repair high resistance or open connection in check wires.

Table 26: Track Module Indications (Remedies)

Panel Indication – Diagnosis	Description	Cause	Remedy
CHK3	The receiver and check wires have low reading (train at EZ=0), but island is not occupied. (Only shows when GCP and Island share same pair of transmit wires).	Poor connection of receive/check wires or poor shunting or bad calibration data.	Locate and repair high resistance or open connection in check/receive wires. Recalibrate island.
CHK4 Gain Check Error (Diag1010)	Receiver and check signal levels differ by a significant amount	If a train is present: <ul style="list-style-type: none"> • High resistance in transmitter track wires 	Locate and repair: <ul style="list-style-type: none"> • High resistance connections in transmitter track wires
CHK4 Gain Check Error (Diag1010)	Receiver and check signal levels differ by a significant amount	If no train is present: <ul style="list-style-type: none"> • High resistance in receiver or check receiver track wires • open track connection 	Locate and repair: <ul style="list-style-type: none"> • High resistance connections in receive or check track wires • open connections in receive or check track wires
CKEX Check Wire EX Error (Diag1006)	Check wires and transmit wires are out of phase Generally, occurs at cutover with 6-wire installations	The check wires and transmit wires are misphased.	Change the check wires connections so that: T1 & C1 are tied together T2 and C2 are tied together

Table 26: Track Module Indications (Remedies)

Panel Indication – Diagnosis	Description	Cause	Remedy
<p>GAPP GCP Approach Calibration Required (Diag1021)</p>	<p>GCP Approach Calibration Required</p>	<p>Approach is uncalibrated An approach reverts to its uncalibrated state when the: GCP is recalibrated Track Module is replaced Template is set to default or a new template is selected Programmed approach distance is changed MCF is changed.</p>	<p>Access the appropriate GCP Calibration Window If the computed approach distance is correct, select the BYPASS button If the computed approach distance is known for this track from a previous calibration, enter the correct value by selecting the EDIT button. If the computed approach distance is incorrect and is unknown, perform the approach calibration as described in Section 6.</p>

Table 26: Track Module Indications (Remedies)

Panel Indication – Diagnosis	Description	Cause	Remedy
<p>GCAL GCP Calibration Required (Diag1020)</p>	<p>GCP Calibration Required</p>	<p>The Track Module is uncalibrated. A Track Module reverts to its uncalibrated state when the: Track Module is replaced MCF software is changed Template is set to default or a new template is selected Track Frequency is changed Approach distance is changed Compensation value is changed Transmit level is changed Directional (bi/uni) mode is changed</p>	<p>Access the appropriate Calibration Select Window and calibrate the GCP as described in Section 6.</p>
<p>GEXP EX Process Error (Diag1016)</p>	<p>Phase (EX) decreases as train approaches crossing</p>	<p>Possibly caused by: poor shunting high resistance bond generally located near the GCP track wires</p>	<p>Locate and repair high resistance bonds</p>
<p>GFRQ No GCP frequency Selected (Diag1012)</p>	<p>No track frequency set</p>	<p>MS/GCP Operation has been programmed as ON, but no GCP frequency has been selected</p>	<p>Select a GCP frequency from the GCP: track n program menu</p>

Table 26: Track Module Indications (Remedies)

Panel Indication – Diagnosis	Description	Cause	Remedy
GHWR Track Hardware Error (Diag1019)	Track Hardware Error	This occurs when the Track Module detects that its hardware is not operating correctly	Replace the module
GIPS IPS Mode (Diag1013)	Inbound poor shunting (IPS) detected	IPS Mode is shown when the Track Module is configured with the Enhanced Detection option On and the module detects inbound poor shunting	None
GLCK Power Up Lockout Error (Diag1018)	EZ or Check EZ low after reboot	The EZ or Check EZ values are less than three after a power up. This could be caused by a train shunting the tracks near the feed point open receive or check wires	If a train is present, clear the lockout by selecting the Release Track icon on diagnostic terminal Status Screen If no trains are present repair the check and/or receive wires as required.

Table 26: Track Module Indications (Remedies)

Panel Indication – Diagnosis	Description	Cause	Remedy
<p>GLIN GCP Linearization Required (Diag1022)</p>	<p>GCP Linearization Calibration Required</p>	<p>Linearization is uncalibrated Linearization reverts to its uncalibrated state when the: GCP is recalibrated Track Module is replaced Template is set to default or a new template is selected Programmed approach distance is changed MCF is changed</p>	<p>Go to the Setup Track Linearization Screen. If the linearization value is correct, select the BYPASS button. If the linearization value is known for this track from a previous calibration, enter the correct value by selecting the EDIT button. If the linearization value is incorrect or not known perform a linearization calibration as described in Section 6.</p>
<p>GOFS Out of Service Error</p>	<p>MS/GCP Operation is Out of Service</p>		
<p>GPRM Program- Error</p>	<p>The Track Module is configured to expect an island and the prime has a non-zero offset value</p>	<p>Prime is set not set to zero.</p>	<p>Set the prime to zero offset, if applicable. If island is used at remote location, use a DAX not the prime. Set the Island Connection to NO Islands if no island is intended.</p>

Table 26: Track Module Indications (Remedies)

Panel Indication – Diagnosis	Description	Cause	Remedy
GRCV Receiver Error (Diag1014) or (Diag1015)	Track Module internal receiver channels differ	Unacceptable difference between the redundant receivers on the Track Module is detected	Replace Track Module
GSLV GCP Slave Signal Error (Diag1023)	Slaving Error	The Track Module is not receiving clock sync from the Primary Track Module. The primary Track Module is normally the module in the Track 1 Slot.	If only one Track Module is reporting the error, replace that module. If all Track Modules are reporting the error, replace the primary Track Module (generally T1).
GSTB GCP Stabilizing (Diag1001)	20 sec. stabilization period prior to start of normal operation.	System startup	Wait
GXMT Transmitter Error (Diag1011)	Transmitter cannot maintain a constant current	All installation: <ul style="list-style-type: none"> • High resistance or open transmit track wire • High resistance or open track wire rail connection 	Locate and repair open transmit wires or high resistance transmit wires connections.
GXMT Transmitter Error (Diag1011)	Transmitter cannot maintain a constant current	Unidirectional installations only: <ul style="list-style-type: none"> • open termination • open coupler • open bond 	Locate and repair: <ul style="list-style-type: none"> • open termination • open coupler • open bond

Table 26: Track Module Indications (Remedies)

Panel Indication – Diagnosis	Description	Cause	Remedy
HIEZ High EZ (Diag1002)	High EZ or high EZ check value detected	Ballast has increased significantly since calibration	Recalibrate only after verifying that no other cause exists.
HIEZ High EZ (Diag1002)	High EZ or high EZ check value detected	Broken rail	Repair broken rail
HIEZ High EZ (Diag1002)	High EZ or high EZ check value detected	Defective insulated joint coupler	Replace defective insulated joint coupler
HIEZ High EZ (Diag1002)	High EZ or high EZ check value detected	Defective termination shunt	Repair defective termination shunt
HIEZ High EZ (Diag1002)	High EZ or high EZ check value detected	High resistance termination shunt connection	Repair high resistance connection to termination shunt
HIEZ High EZ (Diag1002)	High EZ or high EZ check value detected	High-resistance track bond wire connection	Repair high resistance bond
HIEZ High EZ (Diag1002)	High EZ or high EZ check value detected	Poor calibration	Recalibrate only after verifying that no other cause exists.
ICAL Island Calibration Required (Diag1305)	Island requires calibration	Calibration is required when the: Track Module is replaced MCF is changed Template is set to default or a new template is selected Island frequency is changed	Access the appropriate Calibration Select Window and calibrate the island as described in Section 6.

Table 26: Track Module Indications (Remedies)

Panel Indication – Diagnosis	Description	Cause	Remedy
ICON Island Connect Error	The GCP Island Connection indicates that an island is connected, but no island is turned on.	Faulty programming	Verify programming against plan.
IFRQ No Island Frequency Selected (Diag1300)	No island frequency has been programmed	An Island Operation is requested but no island frequency is selected	Select an island frequency from the Program menu
ISTB Island Stabilizing (Diag1301)	Island stabilizing after a power up	On startup the Track module initiates a 20 second timeout to allow the island output to stabilize	Wait
IXMT Island Transmitter Error (Diag1304)	Island cannot supply a constant current	All installations Track Module detects: high resistance transmit track wire open transmit track wire high resistance or open track wire rail connection	Locate and repair defective wiring or connections
IXMT Island Transmitter Error (Diag1304)	Island cannot supply a constant current	Unidirectional installations Track Module also detects: <ul style="list-style-type: none"> • open termination • open joint coupler • open bond 	Locate and repair open termination, joint coupler, or bond
LWEX Low EX (Diag1003)	Low track ballast resistance detected.	Broken rail	Repair broken rail

Table 26: Track Module Indications (Remedies)

Panel Indication – Diagnosis	Description	Cause	Remedy
LWEX Low EX (Diag1003)	Low track ballast resistance detected.	Low ballast	Determine cause of low ballast and compensate
LWEX Low EX (Diag1003)	Low track ballast resistance detected.	Low ballast and defective insulated joint coupler	Replace defective insulated joint coupler
LWEX Low EX (Diag1003)	Low track ballast resistance detected.	Low ballast and high resistance bond	Repair high resistance bond
LWEX Low EX (Diag1003)	Low track ballast resistance detected.	Mud or other contaminants within ballast	Verify EX Adjust as described in Table 35
LWEX Low EX (Diag1003)	Low track ballast resistance detected.	Poor drainage at crossing	Temporarily shorten the approach (see WARNING on Pg. 88)
LWEX Low EX (Diag1003)	Low track ballast resistance detected.	Salted crossing	Use a lower GCP frequency
LWEZ Low EZ (Diag1004)	Low EZ Detection is programmed ON and its timer interval is exceeded.	A false shunt on the track	Remove false shunts from the track
LWEZ Low EZ (Diag1004)	Low EZ Detection is programmed ON and its timer interval is exceeded.	A false shunt on the track	Check that EZ returns to normal after false shunt removal.
LWEZ Low EZ (Diag1004)	Low EZ Detection is programmed ON and its timer interval is exceeded.	A train is on the approach for a time longer than the timer setting.	Temporarily turn off low EZ detection until train has left.
LWEZ Low EZ (Diag1004)	Low EZ Detection is programmed ON and its timer interval is exceeded.	Open receive track wire	Repair
RECV GCP Recovering (Diag1000)	30 sec. recovery time-out	Clearing of system error	Wait

Table 26: Track Module Indications (Remedies)

Panel Indication – Diagnosis	Description	Cause	Remedy
RECV Island Recovering (Diag1303)	Island recovering after self-test	The Track module initiates a 30-second recovery timeout after an island error has cleared.	Wait
RXEX Receive Wire EX Error (Diag1005)	Transmit and receive wires are out of phase Generally observed at cutover	The receive and transmit wires are connected to the wrong rail (misphased)	Change the track wire connections so that: T1 & R1 are connected to rail 1 T2 & R2 are connected to rail 2
UCFG No Communications (Diag1017)	No communication to a Track Module.	Track Module is not communicating with the CPU.	Verify that a module is in appropriate slot
UCFG No Communications (Diag1017)	No communication to a Track Module.	Track Module is not communicating with the CPU.	Replace the module if the Track Module is continuously rebooting. BOOT displays on 4-character display at one minute (approximate) intervals.
UCFG No Communications (Diag1017)	No communication to a Track Module.	Track Module is not communicating with the CPU.	If the Track Module is not continuously rebooting determine if UCFG is shown on the module's display. If only this module displays UCFG , replace it if all Track Modules display UCFG replace the CPU Module

Table 26: Track Module Indications (Remedies)

Panel Indication – Diagnosis	Description	Cause	Remedy
VOER OUT Correspondence Check Error (Diag1200)	No Vital output voltage	A vital output is commanded to be on but is producing no voltage. May be caused by: Open or shorted output Defective Track Module.	Check for an open or shorted output and repair as required. If the output is not open or shorted, replace the Track Module

Table 27: Diagnosing PSO Module Problems

Diag Display / Description	Causes	Remedy
PFXR PSO Transmitter Frequency Error / No Transmitter frequency is set	The PSO Transmitter does not have a valid frequency selected.	Select a valid frequency from the Program menu
PXMT PSO Transmitter Error / PSO Transmitter detects a fault	The PSO Transmitter is detecting a fault in the connections.	Check that the transmit wires are connected properly. Check for open terminations, open couplers, or open bonds
1FRQ or 2FRQ PSO Receiver Frequency Error / No Receiver frequency is programmed	The PSO Receiver does not have a valid frequency selected.	Select a frequency from the Program menu.
1CAL or 2CAL PSO Receiver Calibration Error () / Calibration is required	The PSO Receiver requires calibration	Verify that Receiver is programmed correctly. Check Receive Value. If value is 90, then the PSO was calibrated with bad test shunt. Repeat Calibration

Table 28: Diagnosing SSCC Module Problems

Diag Display / Description	Cause	Remedy
Crossing Bank Failure (Diag2001) / SSCC Illi module lamp drive output failure	Lamp driver bank A has failed.	Replace the SSCC Illi module
Lamp Neutral Wire Open (Diag2002) / The SSCC Illi has detected open lamp neutral wire	Lamp neutral wire is open	Repair open neutral wire to lamps or disable Lamp Neutral Test if LED lights are used.
Low Battery Warning (Diag2003) / SSCC Illi detected low battery voltage	Battery voltage is below the programmed Low Battery Detection level. This may be caused by:	
	Incorrect Low Battery Detection Level setting	Correct Low Battery Detection Level setting:
	Defective battery charger operation	Perform battery charger maintenance
	Defective Battery operation	Perform battery maintenance
Lamp Voltage Limited (Diag2005)	Lamp voltages are set above the battery terminal voltage.	Reduce the lamp voltages to be less than the battery voltage
No Communications (Diag2017)	SSCC Illi Module in wrong slot	Move Module to appropriate slot.
	SSCC Illi Module defective. Indicated by: POWER light is off HEALTH LED is off for 10 seconds and then on for 10 seconds (module continuously reboots). HEALTH LED flash at fast rate (other modules function properly)	Replace SSCC Illi Module
	CPU Module defective. Track Module displays read UCFG HEALTH LED's of all modules flash at 2 Hz rate	Replace CPU Module

NOTE

The SSCC IIIi module performs a self-diagnostic on each train move.

Where only LEDs lamps are used, a false lamp-neutral-wire-open condition may be detected when **Lamp Neutral Test** is set to **On**.

To avoid a false error indication set the **Lamp Neutral Test** status entry for each active crossing controller to **Off**.

Effective with Revision D of the SSCC IIIi , **FLASH SYNC** is an isolated two-wire output.

If two Revision D or later SSCC IIIi units in the same chassis are operated by separate batteries, the FLASH SYNC returns are connected internally, and no additional connection is required.

Revision D SSCC IIIi Modules can be identified by:

- “D” located at end of Part Number / Bar Code tag on the surface of the circuit board.
- Large metal bracket located on **component side of module**.

When using Revision C SSCC IIIi or earlier, or when external SSCC units are connected to a master SSCC IIIi and operated from a different battery, the following wiring must be provided for FLASH SYNC Return:

- If two Revision C SSCC IIIi units in the same chassis are operated by separate batteries, the **N** pins of the SSCC IIIi power and lamp connectors must be wired together.
- If an external SSCC IIIA, SSCC III PLUS, or SSCC IV is connected to a master SSCC IIIi:
- If the SSCC IIIi is Revision C or earlier, the negative terminals of the master SSCC IIIi and external SSCC must be wired together.
- If the SSCC IIIi is Revision D or later, the SSCC IIIi **FLASH SYNC** return (-) must be connected to **N** on the external SSCC.

The terminology for flash sync control differs between a GCP 4000 and an external SSCC device. The GCP 4000 terms Master and Slave SSCC, are called “Flash Sync Out” and “Flash Sync In” respectively in an external SSCC (Master = Flash Synch Out, Slave = Flash Sync In).

Release Track

When problems exist at initial startup or when transferring to or from MAIN and STBY, a 'Release Track' message is displayed as an added precaution during power up.

Either scroll to **Alarms** and select **1) DIAG**, or select the affected track number, then press **2) Alarms**.

The Diag Screen will open displaying any error descriptions. Select any depicted error and a new screen displays possible causes and remedies for that error.

After the cause of the power-up lockout problem is corrected, the system will cycle to release the track.

The GCP 4000 is programmed with self-diagnostic causes and remedies for most common problems. Accessing the information is similar to the method above.

Diagnostics Log

The diagnostic log provides a time and date stamp of all previous errors. Scroll to **Diags & Reports**, select **3) Reports and Logs > 2) Logs >** then **Diagnostic Log**. Use the scrolling arrows to scroll to the Start Date, then select **Enter**. Select the date by using the arrows to select the Start Date and then the Start Time. Then select **Show Diagnostic Log**.

- Can be used to provide important information for intermittent track or equipment problems.
- Log is stored in the Display Module.
- Captures events only while the Display Module is connected to the GCP.
- Can be cleared by maintainer after being reviewed.

Refer to the Troubleshooting Flow Chart, on Figure 13 Page 83 and Figure 14 on Page 84, to assist in system and track problem diagnosis.

Maintenance Call Lamp Output

NOTE

When energized, the MAINT CALL lamp output completes the circuit to the negative CPU battery. A MAINT CALL light can be connected between "B" and MAINT CALL. A series limiting resistor should be used to lower voltage across the lamp and limit the total current to 4 amps.

The Maintenance Call feature can provide an additional level of diagnostics. When the 4000 GCP system is healthy, the maintenance call output is energized.

The maintenance call output de-energizes when:

- The SEAR Ili application program detects low voltage, power off indication or other custom conditions in the railroad specific application program.
- The CPU detects a battery voltage less than the programmed and enabled low battery threshold.
- An enabled SSCC Ili module is unhealthy.
- An enabled SSCC Ili module with low voltage detection "On" detects a battery voltage less than the programmed low battery threshold.
- The maintenance call repeater input is enabled and the maintenance call input is low.

- The maintenance call output is low when using SSCC IV and it detects low battery or vehicle detect health input is used and it is low
- Out of Service inputs are used and they are energized
- SEAR is used but not in session with GCP CPU

Transfer Output

When the 4000 GCP system is healthy, the transfer output is energized (on) as shown by LED2 lit on the active CPU module.

- This output level stops the Transfer Module from counting down and transferring to the opposite side when the Transfer Module is in the auto mode.

The transfer output is de-energized (off) when:

- a module is programmed as used but is not communicating with the CPU.
- MS/GCP or Island operation on a Track Module is unhealthy.
- PSO is unhealthy
- the CPU module cannot provide the correct 12-volt transfer signal to the transfer module

Troubleshooting information regarding each module may be found at:

- CPU Module Table 24
- Track Module: Table 25, and Table 26
- PSO Module, Table 27
- SSCC Illi Module Table 28

Troubleshooting Flowchart

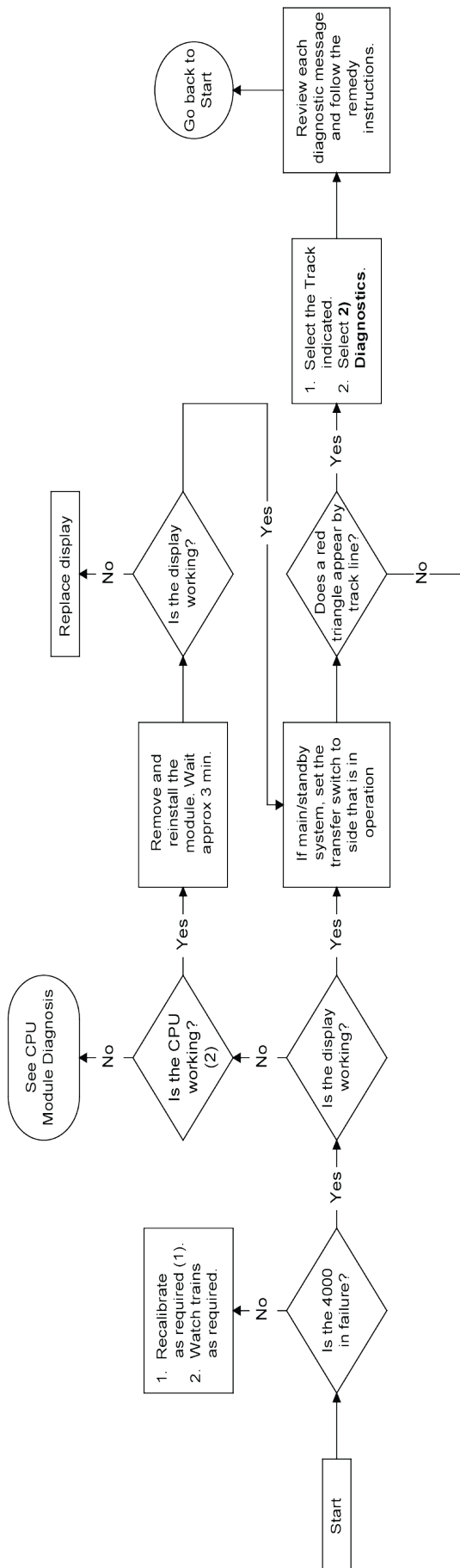
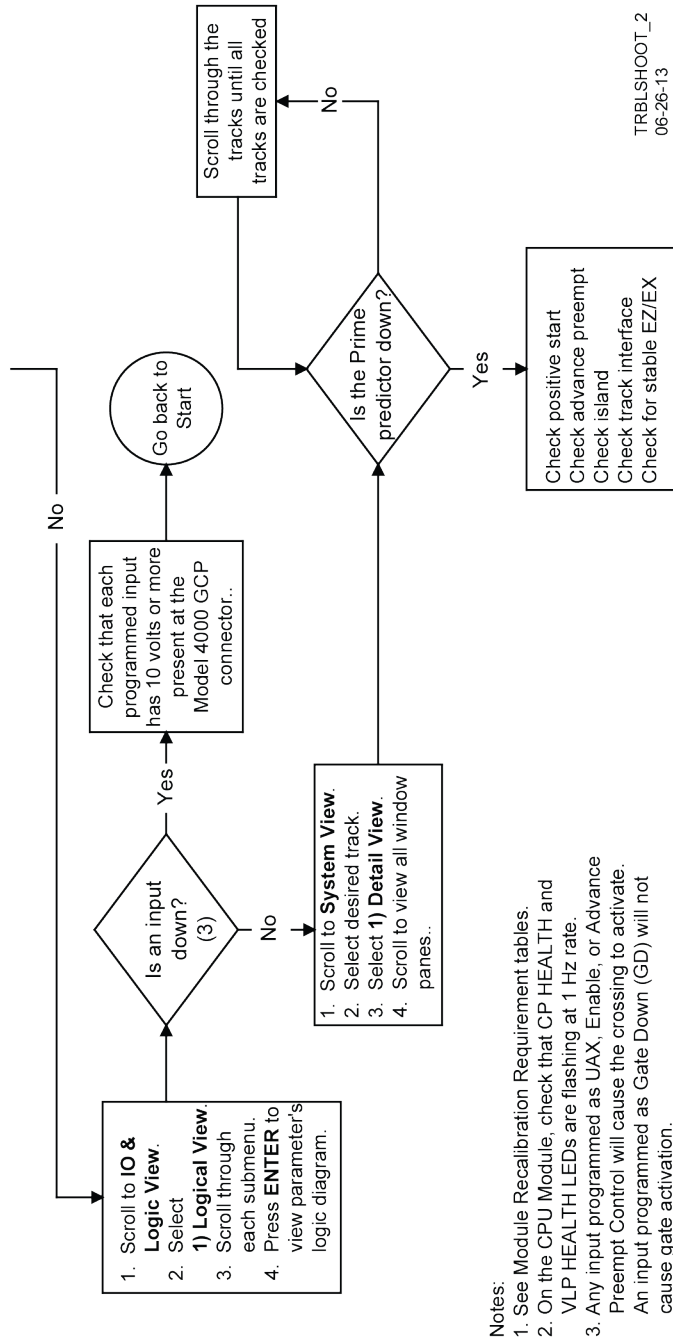

Figure 13: Troubleshooting Flowchart (Part 1)



TRBLSHOOT_2
06-26-13

Notes:
 1. See Module Recalibration Requirement tables.
 2. On the CPU Module, check that CP HEALTH and VLP HEALTH LEDs are flashing at 1 Hz rate.
 3. Any input programmed as UAX, Enable, or Advance Preempt Control will cause the crossing to activate. An input programmed as Gate Down (GD) will not cause gate activation.

Figure 14: Troubleshooting Flowchart (Part 2)

TESTING TRACKSIDE EQUIPMENT

Test trackside equipment as per the steps listed below:

Testing Insulated Joint Couplers

Table 29: Insulated Joint Coupler Test

Step 1	Connect a hardwire shunt on the crossing side of the joint coupler.
Step 2	Note the EZ value: _____
Step 3	Move the hardwire shunt to the termination side of the joint coupler.
Step 4	Note the EZ value: _____
Step 5	Remove the hardwire shunt.
Step 6	Note the difference in EZ values in steps 2 and 4. <ul style="list-style-type: none"> • Wideband shunt coupler - if the difference in EZ is more than 2, the wideband shunt is defective. • Tuned Insulated Joint Coupler, TIJC - (located in the outer half of the approach), if the EZ difference is more than 3, the TIJC is mistuned or defective.

Table 30: PSO Insulated Joint Coupler (Tuned) 7A422-f Test

Step 1	Connect a hardwire shunt on the crossing side of the joint coupler.
Step 2	Note the PSO RX value: _____
Step 3	Move the hardwire shunt to the termination side of the joint coupler.
Step 4	Note the PSO RX value: _____
Step 5	Remove the hardwire shunt.
Step 6	Note the difference in PSO RX values in steps 2 and 4. <ul style="list-style-type: none"> • If difference is greater than ten percent (10%) one or both couplers may be defective.

Testing Rail Bonds

Table 31: Rail Bond Test

Step 1	Note the EX value with no shunt _____
Step 2	Place a hardwire shunt at the 50% point of the approach.
Step 3	Note the EX value: _____
Step 4	Note the difference in EX values in steps 1 and 3. An EX value always increases as a shunt is placed closer to the crossing. If the EX value recorded in step 3 is greater than the EX value in step 1, the bad bond is between the hardwire shunt and the termination. <ul style="list-style-type: none"> • If the EX value recorded in step 3 is lower than the EX value in step 1, the bad bond is between the hardwire shunt and the crossing.

Step 5	<ul style="list-style-type: none"> Continue placing the hardwire shunt closer or further away from the starting point, based on the value in step 3. When the EX value increases, the last bond passed is the bad bond.
---------------	--

EZ must be greater than 15 for this test to work.

Testing Termination Shunts (Hardwire, Wideband and Narrow Band (NBS))

Table 32: Termination Shunt Test

Step 1	Note the EZ value _____
Step 2	Install a hardwire shunt across the termination.
Step 3	<p>Note the change in EZ: _____</p> <p>If termination is hardwire, no EZ change occurs. If termination is wideband, an EZ change of no more than ± 2 occurs.</p> <p>If termination is NBS, EZ can decrease up to 30. Lower frequencies and shorter approaches produce a greater change.</p> <ul style="list-style-type: none"> If termination is NBS and an increase in EZ is noted, then the NBS is defective.

Troubleshooting A De-Energized Predictor

This subsection describes the method of troubleshooting a problem in a system that has previously been in service. The first step in troubleshooting a problem is to determine whether the GCP track circuit continuity and components of a 4000 GCP system are healthy.

When the 4000 GCP system is healthy it shows the following:

- Track windows:
 - Have no trouble icons present on Display
 - have no calibration required messages on Display
 - System Status bar on Status Screen is green
- Health LEDs on all module (CPU, Track, RIO, SSCC IIIi) are flashing slowly (1HZ)
- Transfer Module display time is not counting down
- SEAR Alarm LED's indicate that no alarms are present
- CPU LED 1 is lit, indicating that the Maintenance Call output is on
- CPU LED 2 is lit, indicating that the transfer signal is not allowing transfer
- Power LEDs on all modules are on and steady

If the system is unhealthy use the System Diagnostics or the Track Diagnostics to locate the problem.

Refer to the Troubleshooting Flow Chart, Figure 13 and Figure 14, to assist in system and track problem. If the track module is healthy, predictors can be de-energized for the following reasons:

Table 33: Troubleshooting a De-energized Predictor

Reason	How
The track module senses that EZ is decreasing at a rate that is fast enough to trigger the prediction.	An approaching train.
The predictor (usually Prime and Preempt) has a zero offset distance and the island used by the MS/GCP is de-energized	If the Island LED on the Track Module is off the island is de-energized.
The predictor is running its pickup delay	<p>If the Track Module LED for this predictor is flashing or the Track Detail View shows an hourglass symbol for the predictor, the predictor is running its pickup delay.</p> <ul style="list-style-type: none"> If the predictor does not recover after its programmed pickup delay time, it should be treated as de-energized.
Positive Start is enabled and the EZ level is below the programmed Positive Start EZ Level	<p>Positive start is de-energizing the predictor. Enabled in the GCP: track n pos start program menu. Predictor remains de-energized while the EZ is less than the positive state level plus 5.</p> <ul style="list-style-type: none"> The current Track Module EZ is shown on the module's 4-character display and the Track Window of the Status Screen.
An UAX input is deenergized	A UAX input is programmed for the Track Module and the input is not energized or is running UAX Pickup delay.
A DAX Enable input is deenergized	A DAX Enable input is programmed for the Track Module and the input is not energized or is running DAX Enable Pickup delay.
A Preempt Health input is deenergized	A Preempt Health input is programmed for the Track Module and the input is not energized.
Interference is causing large EZ fluctuations which appear to be an approaching train	The rapid fluctuation of the displayed track EZ level by 5 to 10 points (or more) indicates the presence of interference.

High EZ and Low EX History & Calibrated Approach

When in the track detail screen, selecting VIEW allows selection of the high EZ and low EX history (HEZ LEX) and the Computed Approach distance for that track.

The HEZ and LEX values are useful in determining when the EZ was high and when the EX was low. The maintainer may reset this information after review.

NOTE

Removal of DC power from the 4000 GCP case is not required before removing or installing modules. Prior to removing SSCC Illi modules, remove load from system by opening the lamp, gate control, GP/GD inputs and bell circuits on the surge panel(s). Prior to replacing or re-installing SSCC Illi modules, replace the load by closing the lamp, gate control, GP/GD inputs and bell circuits on the surge panel(s).

Troubleshooting A Physical 4000 GCP Input

To determine the status of the physical inputs and outputs, scroll to **IO & Logic View**. The following options are available:

- 1) Logical View
- 2) IN
- 3) Out
- 4) System States

Selecting **1) Logical View** allows review of the following areas:

- 1) AND – This displays the ANDs and ENABLEs currently programmed.
- 2) OR – This displays the ORs currently programmed
- 3) Internal States – This displays any Internal IO currently programmed
- 4) System States – This display system states, most often the MAINT CALL output. The status of Sim Preempt is shown as Simultaneous Preempt Output. Similarly, the status of Adv Preempt would be shown as Advance Preempt Output and Preempt Hlth input is shown as Preempt Health Input.

After it is determined that a problem is caused by a de-energized physical input, use the following procedure to isolate the cause.

Table 34: Troubleshooting Inputs

Step 1	Determine the connections to the physical inputs by referring to the circuit plans for the location. These inputs may include: <ul style="list-style-type: none"> • a DAX circuit from a remote site • a preempt health input from a traffic preempt relay • other external inputs
Step 2	If the input is connected to other equipment that is not in this bungalow, go to step 5.
Step 3	Verify that the output of the other equipment is energized using either the indications from that equipment or a meter.
Step 4	If the output of the other equipment is energized but the GCP input is not, check the wiring between the equipment and the GCP.

Step 5	<p>Using a meter, check the remote connection input at the point it enters the bungalow.</p> <p>If the input is energized, go to the remote site and check the output.</p> <p>If the input is de-energized, check the wiring from this point through to the GCP terminals.</p>
---------------	--

⚠ WARNING

**IF APPROACH LENGTH IS REDUCED,
MAXIMUM TRAIN SPEED MUST ALSO
BE CORRESPONDINGLY REDUCED.**

NOTE

A power up lockout is indicated by a **Release Track** message that appears at the end of the corresponding Track Status line. The lockout caused by the train shunt (EZ < 3) may be cleared by:

- accessing the Alarm menu
- selecting the displayed message block within the affected Track Status Window

Troubleshooting Maintenance Call (MC) Light Problems

Several operations in the 4000 GCP system will turn-off the MAINT CALL (MC) light. This procedure assumes:

- The warning devices are not activated and modules are healthy, including SSCC IV and SEAR III if used. (If red warning triangles appear, proceed with Troubleshooting Flowchart, Figure 13 and Figure 14)
- No track is out-of-service
- MC operation is being placed in service for the first time and wiring must be checked.

The following procedure checks the most common items first. If the MAINT CALL light does not turn on after a step, proceed to the next step.

1. Observe LED 1 on CPU module (MCF Defined LED's, Figure 20 or Figure 21), or **Maint Call** on **AND Detail** screen
 - If LED 1 is on, or Maint Call is Green, go to step 3.
 - If LED 1 is off, or Maint Call is Red, go to step 2.
2. Refer to the circuit plans for the location and if a Maintenance Call Repeater Input is used, verify that the MC Repeater input is on. Check input LED on corresponding module, or check scroll to **IO & Logic View > 1) Logical View > 4 System States**. Verify the logic tree. **Maint** should be lit.
 - a. Scroll to Program > 3) GCP Programming > 3) Logic Programming > 4) Logic Controls. If the Maint Call Rpt IP Used is set to Yes, an input must be programmed on an input assignment screen to Maint Call Rpt IP
 - b. Scroll to 3) GCP Programming > 6) Input/Output Assignments > 2) Input Assignments, select the proper input and assign IN X.X Maint Call Rpt IP. The input must be energized.

3. Determine that the MC light functions by testing the lamp circuit as follows:
 - a. Measure DC voltage between **B** (+ meter lead) and **MAINT CALL** (MC) out (- meter lead) on the green connector above the CPU.
 - i. If voltage is within 0.5 volts of B, then the lamp or lamp circuit is open and must be repaired.
 - ii. If voltage is less than 1.0 volts, go to next step.
 - a. Measure between **N** (- meter lead) and **MC** (+ meter lead) on the green connector.
 - i. If voltage is within 0.5 volts of B, then the lamp circuit is okay, but the MC output is off.
 1. If LED 1 is lit, replace CPU module
 2. If LED 1 is not lit, go to the next step
4. Battery voltage may be low:
 - a. If **Low Battery Enabled** is set to **ON** (on **11 SITE programming** screen), verify that the voltage on the CPU battery connector is more than the **Low Battery Level** shown.
 - b. If **Low Battery Detection** is set to **Yes** (on **8 SSCC programming, SSCC: 1** screen), verify that the voltage on the SSCC 1 battery connector is more than the **Low Battery Level** shown.
 - c. If **Low Battery Detection** is set to **Yes** (on **8 SSCC programming, SSCC: 2** screen), verify that the voltage on the SSCC 2 battery connector is more than the **Low Battery Level** shown.
5. If a SEAR Ili is used it may monitor power off inputs (POK), external Battery Monitor or other SEAR Ili Application Program specific logic.
 - a. Temporarily turning the SEAR off may isolate the MC problem:
 - i. Scroll to Program View > 3) GCP Programming > 1) Basic Configuration > Module Selection
 - ii. Scroll down to SEAR Used **Yes***
 - iii. Select **Enter**
 - iv. When the SEAR Used screen appears, scroll down and select **No**
 - b. If the MC light turns on, turn the SEAR Ili back on:
 - i. Scroll down to SEAR Used No
 - ii. Select **ENTER**
 - iii. When the SEAR Used screen appears, scroll up and select **Yes**
6. Refer to the circuit plans for the location and:
 - a. Verify that the SEAR Site Setup is accurate.
 - b. Verify all POK inputs are on.

- c. If used, verify that SEAR Ili Application Program MC related parameters are correct. (Refer to SEAR Ili Application Configuration Manual, SIG-0008-XX)
- d. On the Display module, press the SEAR button (on PC with HyperTerminal follow similar steps), then:
 - e. Select MENU
 - f. Press Down Arrow until DIAG/MONITOR is displayed, then press ENTER.
 - g. Press Down Arrow until Network I/O is displayed, then press ENTER.
 - h. Press Left or Right Arrow until MODULE TO MONITOR? displays GCP4K, then press ENTER.
 - i. If GCP4K COMM STATUS is Bad, refer to the circuit plans for the location and verify the ATCS address of the GCP 4000 and the SEAR Ili.
 - i. If ATCS addresses are correct, replace CPU module.
 - ii. If GCP4K COMM STATUS is Good, replace the CPU module.
7. If the MC light stays off, turn SEAR Ili back on:
 - a. Select 2 BASIC Configuration
 - b. On the SEAR Used line, press the No
 - c. When New Value updates to Yes, press Update
8. If the MC light remains off, replace SEAR Ili.
9. If unit is redundant, transfer to opposite set of modules.

 WARNING

AT CROSSINGS USING MEFS XNG02_00.MEF AND EARLIER, GATES WILL BEGIN TO LOWER IMMEDIATELY (WITHOUT GATE DELAY TIME) WHEN THE TRANSFER SWITCH IS USED TO SWAP BETWEEN HEALTHY UNITS. USE CAUTION WHEN TRANSFERRING CONTROL TO AVOID GATES HITTING VEHICLES OR PEDESTRIANS.

10. If the MC lamp turns on, replace the initial CPU module.
11. If the MC lamp stays off, call Siemens Rail Technical Support.

TESTING FOR TRACK CIRCUIT ISSUES

Track Circuit Problems

When a failure occurs in a bi-directional GCP track circuit, the EZ and CHECK EZ on the Detailed Status View will generally change in relationship to the normal range and possibly to each other as follows:

1. If EZ and Check EZ move higher or lower than normal, but remain relatively equal to each other, the track circuit problem lies on the transmitter side of the crossing.
2. If EZ and Check EZ move higher or lower than normal, but their values differ by more than 5, the track circuit problem most likely lies on the receiver side of the crossing or in the island circuit of the crossing, if used.

Low EX

A Low EX condition exists when EX is below 39.

If a low EX condition is occurring at a cutover of a new installation, check the following:

3. Defective Bonds
4. Defective insulated joint couplers
5. Missing battery choke in approaches
6. Defective gauge rods or switch rods
7. Open termination shunt
8. Improper application of other frequency NBS in the approaches.

When low EX occurs at an in-service crossing, follow the steps shown in **Table 35** to determine whether the Low EX Adjustment can safely be lowered below 39.

9. Low EX condition commonly occurs at an in-service crossing when track conditions are extremely wet and possibly salted.



**DO NOT LOWER THE LOW EX
ADJUSTMENT BELOW 39 IF THERE IS
NOT A 5 POINT DROP IN EZ.**

Table 35: Low EX Qualification Test

Step 1	With EX below 39, connect a hardwire shunt at the termination shunt of the longest approach.
Step 2	Record the EZ value: _____
Step 3	Move the hardwire shunt in to the 90% point of the approach.
Step 4	Record the EZ value: _____ 10. If the EZ value at the 90% point is at least 5 less than the EZ value at the termination shunt (step 2), the Low EX Adjustment can safely be lowered below 39, proceed to step 5. 11. If the EZ values do not drop 5 points, the Low EX Adjustment cannot be safely lowered below 39. 12. Do not continue.
Step 5	Scroll to Program View > 8) GCP Miscellaneous . The TRK “N”: GCP Miscellaneous screen opens
Step 6	Press Enter to select the Low EX Adjustment value. The Low EX Adjustment screen opens.
Step 7	Enter a new EX value between 34 and 39, press Enter . The new value appears as the Low EX Adjustment entry value
Step 8	Press the BACK button until Program View appears again.

Nuisance Activation – Rail Phase Check

In situations where EZ shifting between 5 to 20 points concurrently with EX is shifting from 2 to 5 points, checking the rail to ground voltage is required. From within the enclosure, measure the AC voltage from RCV1 to ground, and then measure the AC voltage from RCV2 to ground. The ideal measurement is identical. If V_{RCV1} differs from V_{RCV2} by approximately 0.75V or higher, nuisance activations may occur. Typically, the cause of this problem is a failing insulating joint or arrestor in the signal block

OUT OF SERVICE FEATURE



THE RAILROAD PROCEDURES GOVERNING HOW TO TAKE A TRACK CIRCUIT OUT OF SERVICE SHALL BE FOLLOWED. THE INSTRUCTIONS IN THIS SECTION MAY BE FOLLOWED ONLY IF ALLOWED BY THE RAILROAD.

This section describes:

- How to take a track out of service.
- What logic functions are bypassed and the effect of that bypass on other modules and I/O
- How to place the track circuits(s) back in operation

Take a track Out of Service:

- Access the Out of Service Menu on the display by selecting the desired track in the **System View** window on the display. The **Track “N”** Options window opens.
- Select **6) Out Of Service** from the drop down display.

If the incorrect track is displayed, use the left and right scroll bars to navigate to the desired track.

- Select **1) GCP**. The **TRACK “N” TAKE GCP OUT OF SERVICE** window opens.
- Select **1) Take Track “N” GCP Out of Service**.
- When **1) Take Track “N” GCP Out of Service** is selected, the following message appears:

Are you sure you want to take GCP Out of Service?

Press Enter to Confirm and Continue

OR

Press Back to Cancel Request

- Once the GCP approach is taken out of service the **Track “N” OOS** window shows **1) GCP Out of Service**

If the Island is also to be taken out of service

- Select **2) Island**. The **Track “N” ISL Out of Service** window opens.
- Select **1) Take Track “N” ISL Out of Service**
- When **1) Take Track “N” ISL Out of Service** is selected, the following message appears:

Are you sure you want to take ISL Out of Service?

Press Enter to Confirm and Continue

OR

Press Back to Cancel Request

- Once the Island is taken out of service the **Track “N” OOS** window shows **2) ISL Out of Service**.

The out of service selection has a timer option, which will restore the track back to service after the specified time. The default setting for the timer is 1 hour. The range is 1 to 23 hours.

The OUT OF SERVICE TIMEOUT: YES can be turned off by selecting **3) Settings**, then **NO**, which will take the track out of service until returned to service by the user. The OOS Settings can be viewed at **3) Settings**, which displays whether Timeout is selected, and the specified time.

To change the OOS settings, scroll to **Program View > 3) GCP Programming > 1) Basic Configuration > 6) Out of Service**. The **Out of Service** window opens, depicting the following parameters:

- **+OOS Control**
- **+OOS Timeout**
- **OOS Timeout**
 - a. **+OOS Control** has the following parameters:
 - i. Display*
 - ii. Display+OOS IPs
 - iii. OOS IPs
 - iv. 4000 Case OOS IP
- **+OOS Timeout** turns OOS Timer off or on
- **OOS Timeout** - The time period can be changed by selecting **OOS TIMEOUT: 1 HRS**. The NEW VALUE of 2 to 23 hours can be entered on the keypad, then press **Enter**.

NOTE

If one or more tracks are taken out of service, the Out of Service Timeout covers all tracks taken out of service with one-time interval.

If the timer is running for one or more tracks out of service, and it is desired to take another track out of service for an added amount of time, do the following:

- Return all tracks to service.
- Edit the Out of Service Timeout to the new value.
- Take the tracks out of service.

The following will be displayed to indicate the final selections.

When the **Track “N” OOS** screen is closed by selecting the **BACK** button, the display returns to the **System View** window. Note that the out of service track is alternately flashing white and light blue at the end of the track row.

To return the track(s) and island(s) to service:

- Select the desired track by selecting that track number. The **Track “N” Options** window opens.
- Select **6) Out of Service**.
- Select **2) Island**. The **Track :N: ISL Back in Service** window opens.

- Select **1) Put Track “N” ISL Back in Service**. The **Track :N: ISL Back in Service** window closes.
- On the **Track “N” OOS** screen, **2) Island** now reads **In Service**.
- Select **1) GCP**. The **Track :N: GCP Back in Service** window opens.
- Select **1) Put Track “N” GCP Back in Service**. The **Track :N: GCP Back in Service** window closes.
- On the **Track “N” OOS** screen, **1) GCP** now reads **In Service**.
- Exit the **Track “N” OOS** window by selecting **BACK**.
- The **System View** screen appears, with the track previously OOS no longer displaying **OOS** at the end of the track row.

⚠ WARNING

REQUIRED OPERATIONAL TESTS SHALL BE PERFORMED IN ACCORDANCE WITH RAILROAD PROCEDURES WHEN RESTORING TRACKS TO SERVICE.

Out of Service Inputs

Sometimes it is desired to have an additional step be required to take a track out of service. When Out of Service Inputs are programmed, an input must be energized as well as the track out of service box checked for the track to be taken out of service.

⚠ WARNING

THE RAILROAD PROCEDURES FOR APPLYING TEMPORARY JUMPERS MUST BE FOLLOWED WHEN ENERGIZING THE “OUT OF SERVICE” INPUT(S).

To enable an OOS Input:

- Scroll to **Program View > 3) GCP Programming > 1) Basic Configuration > 6) Out of Service**. The Out of Service window opens, depicting the following parameters:
- Select **+OOS Control** by pressing **ENTER**. The **OOS Control** window opens with the following parameters:
 - a. Display*
 - b. Display+OOS IPs
 - c. OOS IPs
 - d. 4000 Case OOS IP
- Select the type of input desired then select **Enter**.
- Select **BACK** until the **Main Program Menu** appears.
- Scroll to **3) GCP Programming > 6) Input/Output Assignments > 2) Input Assignments**, select the proper input and assign **IN X.X Out of Service IP “N”**.
- If out of service inputs are set to Yes, the proper input must be energized.

Return Track to Service

De-energizing the Out of Service Input or selecting **Put ISL/GCP Back In Service** returns the track to service.

NOTE

If the Transfer Module transfers while a track is out of service, the track will be returned to service and may activate the warning devices.

SOFTWARE VERSIONS

To determine the software versions, scroll to **Diags & Reports > 3) Reports & Logs > 1) Reports > 2) Version Report**. The **Version Report** window opens. Select **3) Software Information**. The Software Information for Slots 1 – 9 is listed.

The Display software versions are determined by navigating back using the **Back** button to the **Version Report** window. Select **5) Display Module Non-Vital CPU**. The Software Information for the Display is listed.

The SEAR Ili software versions are determined by navigating back using the **Back** button to the **Version Report** window. Select **6) SEAR**. The Software Information for the SEAR is listed.

PROGRAMMING

The design on the circuit plans for the crossing warning system determines the programming of the 4000 GCP.

WARNING

PROGRAM CHANGES MUST BE PERFORMED IN ACCORDANCE WITH RAILROAD PROCEDURES.

SYSTEM OPERATION MUST BE VERIFIED PRIOR TO PLACING SYSTEM IN SERVICE OR FOLLOWING PROGRAMMING, HARDWARE, OR WIRING CHANGES.

Templates are used to simplify 4000 GCP programming. The GCP provides several templates that represent common track circuit arrangements, including bidirectional, unidirectional, end of siding, and crossovers, including remote GCPs.

Each template:

- Provides the simplified programming menus and programming defaults for a typical track arrangement and application
- Predefines default parameters for train detection
- Has rules that specify which:
 - a. Track circuits are unidirectional and bidirectional
 - b. Track circuits have islands (indicated by an *)
 - c. Islands are connected to multiple track circuits
 - d. Track circuits are remote and DAX towards the crossing
 - e. Track circuits are remote and DAX away from the crossing

PROGRAMMING THE GCP 4000

NOTE

Please refer to the Railroad Installation Drawing or the Installation Plans for the exact parameters to be entered when programming the GCP 4000.

To program the GCP 4000, scroll to **Program View > 3) GCP Programming...** on the Display. The **Main Program Menu** Window opens.

The GCP can then be programmed by going through each individual submenu, i.e., **1 Template programming, 2 BASIC configuration, 5 ISLAND programming, 9 IO assignment**, etc.

WARNING

THE GCP 4000 DISPLAY IS NOT CURRENTLY CONFIGURED TO ACCEPT DISTANCES MEASURED IN METERS. THEREFORE, NO METRIC DISTANCE UNITS ARE USED TO PROGRAM PARAMETER VALUES ON THE GCP 4000.

PASSWORDS

NOTE

Asterisks (*) that appear in the menus depict parameters that may reveal additional parameters when chosen

The GCP 4000 Crossing System with an A80485-1 Display has a two-tier password system. The two types of passwords are Field Passwords and Supervisor Passwords. Supervisor Passwords are assigned to senior personnel who design the programming of the GCP. Field passwords are assigned to Field Maintainers. The Field Passwords are discussed in this manual.

There are now four methods of access to the 4000 GCP's editable parameters:

- No Passwords Used:
 - When both passwords are set to NO, anyone who gains access to the 4000 GCP can edit any parameter.
- Field Password only used
 - When the Field Password only is set to Yes, no parameters may be edited without the password, and all parameters may be edited when the Field Password is entered.
- Supervisor Password only used
 - When the Supervisor Password only is set to Yes, field parameters may be edited without the password, but once the password is entered, all parameters may be edited.
- Field Password and Supervisor Password both set to Yes.
 - When Field Password and Supervisor Password are both set to Yes, no parameters may be edited without either password being entered: if the Field Password is entered, only those parameters editable by field personnel may be edited; if the Supervisor Password is entered, all parameters may be edited.

Information regarding Supervisor Passwords and further discussion of all GCP parameters are found in Siemens Rail's Application Guidelines for the Microprocessor Based Grade Crossing Predictor Model 4000 Family, Document Number SIG-00-08-06.

LOGIN USING THE FIELD PASSWORD

Begin the login process by scrolling to **Program View > 3) GCP Programming...** on the Display. The **Enter Password** Window opens.

Enter the password and select **OK**. The Main Program Window Opens.

ATCS INFORMATION

ATCS Communication

The ATCS communication window displays a real-time view of **in** and **out** vital messages for each vital serial communications link. Radio DAX link sessions are shown by LED #13 and LED #14 on the active CPU module.

Table 36: ATCS Comms Display Acronyms

Display Acronyms	Definition
AND1 – AND4	AND functions
T1P1	Track 1 Prime
T1P2 – T1P8	Track 1 DAX A-H
T1P9	Track 1 Preempt

Connecting Echelon® LONTALK Wiring



BECAUSE THE ECHELON® INTERFACE IS NOT SURGE PROTECTED, NETWORK CONNECTIONS MUST BE RESTRICTED TO THE EQUIPMENT CONTAINED INSIDE A SIGNAL CASE OR BUNGALOW.

NOTE

For additional information concerning the Echelon® LAN, contact Siemens Mobility, Inc, Technical Support.

Vital ATCS serial protocol data may be incorporated with the LONTALK® protocol to facilitate:

- crossing control functions
- remote prediction operations via Spread Spectrum Radio (SSR)
- vital communications with other Siemens Rail vital controllers

The following rules applies when using the Echelon LAN:

- Wire size is from #22AWG to #16AWG, stranded twisted pair.
- Each connection (node) must be wired in a daisy-chained bus configuration, no drops allowed (see Figure 16).
- The maximum wiring length of LAN bus wiring is 425 ft (129.5 m) within a signal case or bungalow, but wiring should be kept as short as practical.
- A maximum of 8 connections (nodes) is recommended within 53 ft. (15.2 m) of cable. If necessary additional cable may be added so that no more than 8 nodes are located within any 53 ft/15.2 m length. If additional connections are required, contact Siemens Rail Technical Support for assistance.
- In general, Echelon network requires a terminator for proper data transmission performance.
- The Echelon network can be connected to ECH1 on the 4000 GCP and the Echelon terminator can be connected to ECH2 on the 4000 GCP
- Order Network Echelon Termination Unit, part number 8000-80078-001
- For further information, see Siemens Rail's Echelon Configuration Handbook, COM-00-07-09.

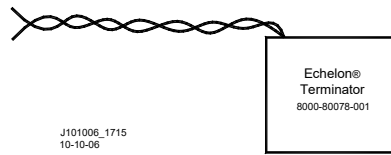

Figure 15: Siemens Rail Echelon Terminator

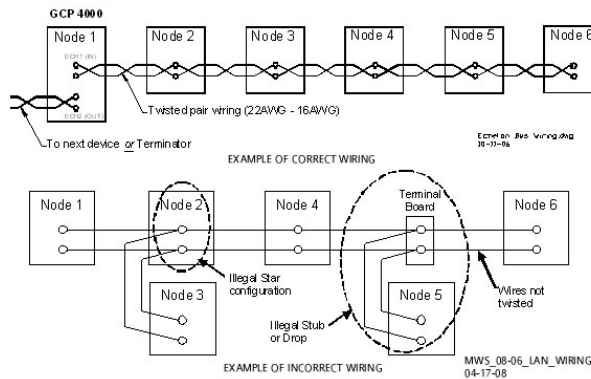

Figure 16: Echelon LAN Wiring Examples

ATCS SITE ID ENTRY

Selecting the **1) ATCS Site Id** entry on the **Site Programming** menu window opens the **SIN Settings** dialog window. This dialog window:

- Displays the current Site Identification Number (SIN)
- Allows the current SIN to be changed
- A SIN may be changed as described in Table 37

⚠ WARNING

CHANGING THE SITE IDENTIFICATION NUMBER WILL RESULT IN ACTIVATION OF WARNING DEVICES. BEFORE CHANGING THE SITE IDENTIFICATION NUMBER, ENSURE THAT ADEQUATE PRECAUTIONS ARE TAKEN TO WARN PEDESTRIANS, PERSONNEL, TRAINS AND VEHICLES IN THE AREA UNTIL PROPER SYSTEM OPERATION HAS BEEN VERIFIED.

Table 37: Changing Site ID Number

Step 1	Select the 1) ATCS Site Id entry on the Site Programming menu window The SIN Settings dialog window displays.
Step 2	The Current Site ID Number (SIN) is displayed in the SIN Setting text box. Select Enter . The Set SIN text
Step 3	Clear the current SIN entry by pressing the Left Arrow until only a zero (0) appears. Then either use the keypad to manually enter the numbers or use the Up or Down Arrows to increment or decrement the displayed number until the correct number is displayed. Then select the Right Arrow to move to the next digit. When the correct SIN is displayed, press the Enter button.
Step 4	An Information window opens that states: Press SEL or NAV button on CPU. Press any button to continue.
Step 5	<u>Press the SEL or CPU button on the front of the CPU module.</u> <ul style="list-style-type: none"> The new SIN is embedded in the Chassis Identification Chip (CIC).
Step 6	The new SIN appears in the Current ATCS Site ID line of the Sin Settings window.
Step 7	Select the Back button until the Main Program Menu screen is displayed.
Step 9	Briefly cycle power to the power connector located above the CPU module. This can also be accomplished by cycling the Transfer Switch on redundant units. The CPU reboots. <ul style="list-style-type: none"> The CPU module identifies the new SIN as the current site address

UPLOAD SOFTWARE USING USB DEVICE

USB Devices are used with the A80485-1 Display to upload software or download reports and files. Using USB devices allows GCP 4000 files to be saved to or uploaded from a USB drive. The following actions may be performed using the USB Device:

- Set Up A USB Device For Use
- Installing Software Using A USB Device
- Configuration File Activity Using USB Device
- Downloading Reports And Logs
- SEAR Transfers

SET UP A USB DEVICE FOR USE

New software issued by Siemens Rail for the GCP 4000 is installed via the A80485-1 Display Module using a USB Device.

WARNING

UPLOADING A NEW CONFIGURATION, MEF, OR MCF WILL PLACE THE GCP IN A RESTRICTIVE STATE AND ACTIVATE THE CROSSING WARNING SYSTEM.

WHEN USING MCF GCP-T6X-01-2.MCF OR EARLIER GATES WILL BEGIN TO LOWER IMMEDIATELY (WITH GATE DELAY). WITH LATER MCF'S, GATES WILL BEGIN TO LOWER AFTER GATE DELAY PASSES.

BEFORE UPLOADING BEGINS, TAKE ADEQUATE PRECAUTIONS TO WARN ANY PEDESTRIANS, PERSONNEL, TRAINS, AND VEHICLES IN THE AREA UNTIL PROPER SYSTEM OPERATION IS VERIFIED.

DURING MODULE CHANGE OUT, SOFTWARE REVISION, REBOOT AND CALIBRATION PROCEDURES, WARNING DEVICES MAY NOT OPERATE AS INTENDED. TAKE ALTERNATE MEANS TO WARN VEHICULAR TRAFFIC, PEDESTRIANS, AND EMPLOYEES.

TESTS MUST BE PERFORMED TO VERIFY PROPER OPERATION OF GCP PRIOR TO PLACING THE SYSTEM BACK IN SERVICE.

CAUTION

TO MINIMIZE THE TIME THAT SIGNALS ARE IN A RESTRICTIVE STATE, IF THE EXISTING CONFIGURATION NEEDS TO BE SAVED, SAVE IT PRIOR TO SELECTING "UPLOAD CONFIGURATION" FROM THE USB WIZARD MENU.

NOTE

Follow railroad specific procedures for installing software in vital signal equipment. Companies may restrict who may install software and what additional documentation and operational checks are required.

When working with transferring files, the following definitions apply:

- Download – The transfer of data from GCP to USB.
- Upload – The transfer of data from USB to GCP.

Future software revisions will be issued with instructions that describe which module the software is to be loaded into. Such software instructions may supersede portions of this manual.

The following GCP 4000 file types can be uploaded from a USB drive connected to the Display Module:

- Module Configuration Files (MCF)
- Module Executable Files (MEF)
- SEAR Ili Executable Files (BIN)
- Configuration Files (PAC)
- Control Description Language Files(CDL)

Creating the USB Device File Structure

Uploading or downloading files between the GCP and the USB Device requires that a specific file structure be created on the USB Device. The system looks for specific file folders to find or place Application, Executive, Configuration or Report files.

The file structure is as follows:

- SAFETRAN
 - <DOT#>-<SITE NAME>
 - GCP4000
 - CONFIGURATIONS
 - .PAC FILES
 - REPORTS
 - <YYYY><MON>
 - GCP4000
 - APPLICATIONS
 - .MCF
 - .CDL
 - EXECUTIVES
 - .MEF
 - .TGZ

The types of information found in each folder is as follows (file names depicted may or may not be valid and are shown merely as examples):

- APPLICATIONS: The primary GCP Master Configuration file:
 - GCP-T6X-02-5.MCF
- EXECUTIVES: The executable module files:
 - VPH03_30.MEF
 - NCG03_40.MEF
 - GCP03_90.MEF
 - GCP00_40.MEF
 - XNG04_00.MEF

- 9V816A01.C
- 9V725_A01AA.BIN
- RIO01_07.MEF
- 9VC15_A01.A
- NG5K_MEF_1.0.23R.TGZ
- CONFIGURATIONS: The GCP PAC file
 - CONFIG_679352.A-130321.PAC
- REPORTS
 - Config. Report
 - MAINT_456123a--1969Dec31 To 2013Mar21
 - system_report_21-Mar-2013.txt
 - SEAR Application Logs
 - SEAR_APP-134.1-1969Dec31 To 2013Mar21
 - SEAR Event Logs
 - SEAR_EVT-134.1-2013Mar20 To 2013Mar21
 - SEAR System Log
 - TMPSEAR_SYSLOG_2013Mar21.txt
 - SEAR Incident Reports
 - SEAR_INCDT-1-134.1
 - SEAR_INCDT-2-134.1
 - SEAR_INCDT-3-134.1
 - SEAR_INCDT-4-134.1
 - SEAR_INCDT-5-134.1
 - Status Log
 - GCPSTATUS0CP679352-2013Mar21082538.txt
 - GCPSTATUS1VLP2679352-2013Mar21091216.txt
 - GCPSTATUS2Trk679352-2013Mar21084935.txt
 - GCPSTATUS8SSCC IIIi679352-2013Mar21083755.txt
 - GCPSTATUS9SSCC IIIi679352-2013Mar21081425.txt
 - Summary Log
 - GCPSUMMARY0CP679352-2013Mar21082538.txt
 - GCPSUMMARY1VLP2679352-2013Mar21091216.txt
 - GCPSUMMARY2Trk679352-2013Mar21084935.txt
 - GCPSUMMARY8SSCC IIIi679352-2013Mar21083755.txt
 - GCPSUMMARY9SSCC IIIi679352-2013Mar21081425.txt
 - Train History
 - TRAIN_HIS-134.1-2013Mar21084315.txt

NOTE

The following section describes up- and downloading software and reports from all GCP Modules except the SEAR Ili onto the USB Drive. SEAR Ili operations are described in the **SEAR OPERATIONS** section.

INSTALLING SOFTWARE USING A USB DRIVE

Insert the USB drive in the USB port on the Display Module to automatically open the USB menu.

A **USB Detected** window opens, stating USB detected.

Press **Back** to continue or **Enter** for USB Menu. The USB window opens. This menu may be returned to at any time by pressing the **Back** button, providing the USB drive is still inserted in the port.

A – Uploading Software onto CPU Module

⚠ WARNING

UPLOADING A NEW CONFIGURATION, MEF, OR MCF WILL PLACE THE GCP IN A RESTRICTIVE STATE AND ACTIVATE THE CROSSING WARNING SYSTEM.

WHEN USING MCF GCP-T6X-01-2.MCF OR EARLIER GATES WILL BEGIN TO LOWER IMMEDIATELY (WITH GATE DELAY). WITH LATER MCF'S, GATES WILL BEGIN TO LOWER AFTER GATE DELAY PASSES.

BEFORE UPLOADING BEGINS, TAKE ADEQUATE PRECAUTIONS TO WARN ANY PEDESTRIANS, PERSONNEL, TRAINS, AND VEHICLES IN THE AREA UNTIL PROPER SYSTEM OPERATION IS VERIFIED.

TESTS MUST BE PERFORMED TO VERIFY PROPER OPERATION OF GCP PRIOR TO PLACING THE SYSTEM BACK IN SERVICE.

⚠ CAUTION

TO MINIMIZE THE TIME THAT SIGNALS ARE IN A RESTRICTIVE STATE, IF THE EXISTING CONFIGURATION NEEDS TO BE SAVED, SAVE IT PRIOR TO SELECTING “UPLOAD CONFIGURATION” FROM THE USB WIZARD MENU.

NOTE

The examples in this section are used to explain how to install software via the display using USB devices. The software and version names may not be the same as seen in an actual GCP. The example will also assume the GCP is a Dual unit and the main modules are loaded first. The procedure is repeated for the standby modules. Where using a cable between the display and the module is called out, use a straight through, male-to-male DB9 serial cable with a null modem connector in place.

There is no specified order when installing/updating software in the GCP

4000. If replacing the CPU MEFs and the MCF as part of the same upgrade; the order of installation is immaterial. However, the MEFs must be loaded prior to attempting to place the GCP back into operation.

Installing Executive software onto the SEAR Ili is detailed in the SEAR OPTIONS section below.

In this example the following files will be loaded into the indicated modules and data port:

- CPU II+ Module
 - a. VLP Port – File: VPH03_30.MEF
 - b. DIAG (CP) Port – File: NCG03_40.MEF
 - c. DIAG (CP) Port – File: GCP-T6X-02-5.mcf, CRC=D1A81B68

The files should be copied to the USB drive as and positioned in the file structure as depicted above.

A.1 – Replace VLP MEF on CPU II+

Perform the following actions:

1. Insert USB Drive in USB slot on front of Display
2. Connect the serial cable between the Diag port on the Display and the VLP port of the CPU module.
3. Select **1) Software Updates > 1) Module Updates**. The **Upload to System** window opens stating: Please check the serial cable connection before uploading. Press any key to continue.
4. Verify that the serial cable is well seated on both ends, then press any key. The Setup program begins loading.
5. Select 1) Change MEF.
6. When asked by the Setup program to **Erase the MEF?**, select **1) Yes**. The Select File window opens.
7. Scroll down to select the file to be installed, in this example VPH03_30.MEF. Select Enter.
8. The new MEF begins loading. This may take a few minutes. While the file is downloading, progress will be indicated on the bottom line of the window.
9. When complete, the Display text provides options to Change the MCF or Exit Setup. Select **0) Exit Setup**. The **Upload to System** window opens and states: **Exit software finished rebooting the module**.
10. Press the **Back** button. Select **0) Exit View**.

A.2 Replace CPU MEF on CPU II+

Perform the following actions:

1. Insert USB Drive in USB slot on front of Display
2. Connect the serial cable between the Diag port on the Display and the DIAG (CP) port of the CPU module.
3. Select **1) Software Updates > 1) Module Updates**. The **Upload to System** window opens stating: Please check the serial cable connection before uploading. Press any key to continue.

4. Verify that the serial cable is well seated on both ends, then press any key. The Setup program begins loading.
5. Select 3) Change MEF.
6. When asked by the Setup program to **Erase the MEF?**, select **1) Yes**. The Select File window opens.
7. Scroll down to select the file to be installed, in this example NGC03_40.MEF. Select Enter.
8. The new MEF begins loading. This may take a few minutes. While the file is downloading, progress will be indicated on the bottom line of the window.
9. When complete, the Display text provides options to Change the MCF or Exit Setup. Select **0) Exit Setup**. The **Upload to System** window opens and states: **Exit software finished rebooting the module**.
10. Press the **Back** button. Select **0) Exit View**.

A.3 - Change the MCF on CPU II+

Perform the following actions:

1. Insert USB Drive in USB slot on front of Display
2. Connect the serial cable between the Diag port on the Display and the DIAG (CP) port of the CPU module.
3. Select **1) Software Updates > 1) Module Updates**. The Upload to System window opens stating: Please check the serial cable connection before uploading. Press any key to continue.
4. Verify that the serial cable is well seated on both ends, then press any key. The Setup program begins loading.
5. Select 2) Change MCF.
6. When asked by the Setup program to **Erase the MCF Flash?**, select **1) Yes**. The Select File window opens.
7. Scroll down to select the file to be installed, in this example GCP-T6X-02-5.MCF. Select Enter.
8. The new MCF begins loading. This may take a few minutes. While the file is downloading, progress will be indicated on the bottom line of the window.

NOTE

After the progress bar reaches 100% and stops, the CPU loads a copy of the file to the ECD on the chassis. This will be indicated on the Display screen by the field turning to a grey background and on the 4-character display on the CPU as **COPYING MCF TO ECD**. Wait until this process completes and the text field has a black background before proceeding.

A.4 – Change the MCFCRC on CPU II+

1. Select 1) Change MCFCRC.
2. The Enter MCF CRC for GCP window opens.
3. Use the **Back** arrow to clear the number that appears in the window and use the keypad to enter the CRC issued with the software revision instructions. The CRC will always be 8 characters consisting of 0 through 9 and A through F. Once the number has been entered and verified correct, select **Enter**.
4. Select 0) Exit Setup. The Upload to System window opens and states: Exit software finished rebooting the module.
5. Press the **Back** button. Select **0) Exit View**.
This completes Installing Software on the CPU Card.

WARNING

UPLOADING A NEW CONFIGURATION, MEF, OR MCF WILL PLACE THE GCP IN A RESTRICTIVE STATE AND ACTIVATE THE CROSSING WARNING SYSTEM.

BEFORE UPLOADING BEGINS, TAKE ADEQUATE PRECAUTIONS TO WARN ANY PEDESTRIANS, PERSONNEL, TRAINS, AND VEHICLES IN THE AREA UNTIL PROPER SYSTEM OPERATION IS VERIFIED.

CAUTION

NOTE

The examples in this section are used to explain how to install software via a USB and Ethernet cable connecting the Display to the CPU III or via the WebUI using an Ethernet cable to connect directly to the CPU III. The software and version names may not be the same as seen in an actual GCP. The example will also assume the GCP is a Dual unit and the main modules are loaded first. The procedure is repeated for the standby modules.

NOTE

There is no specified order when installing/updating software in the GCP 4000. If replacing the CPU MEFs and the MCF as part of the same upgrade; the order of installation is immaterial; however, the MEFs must be loaded prior to attempting to place the GCP back into operation.

In this example, the following files will be loaded into the indicated modules:

- CPU III Module
 - a. VLP MEF: VPH03_30.MEF
 - b. CP MEF: NCG03_40.MEF
 - c. CP MCF: GCP-T6X-02-5.mcf,
CRC=D1A81B68

The files should be copied to the GCP4000/Executive folder of the USB drive if a USB drive is being used instead of the WebUI.

B.1 – Replace CP MEF on CPU III via USB Drive

Perform the following actions:

1. Insert USB Drive in USB slot on front of Display
2. If Maintainer security has been enabled, enter the password. The password is case sensitive. If security is not enabled, proceed to step 3.
3. Connect the Ethernet cable between the Laptop port on the Display and the Laptop port of the CPU III module.
4. From the USB menu, select **3) Software Updates > 3) CPU-III Update**
5. Install an Ethernet cable from the Laptop port on the Display to the Laptop port on the CPU III unit. Verify that the Ethernet cable is well seated on both ends, then press any key.
6. Select **1) Change CP MEF**.
7. When asked by the Setup program to Erase the MEF, select **1) Yes**.
8. The **Select File** window opens.
9. Scroll down to select the file to be installed, in this example: NCG03_40.MEF. Press **Enter**.
10. The new MEF begins loading. This may take a few minutes. While the file is uploading, progress will be indicated on the bottom line of the window.
11. When complete, the Display text provides all of the module update options. If a new MCF needs loading, go to step 6 in the next section, otherwise select **0) Exit Setup**.
12. The **Upload to System** window opens and states: **Exit software finished rebooting the module**.
13. Press the Back button. The USB SW Updates menu is shown (as per Step 4).

B.2 –Replace CP MEF on CPU III via WebUI

1. Connect Ethernet cable from laptop to Laptop port on the front of the CPU III unit

NOTE

The option to set up the WebUI access as secure (https) or non-secure (http) is available by selecting the **Configuration** menu from the WebUI tool bar, then the Non-Vital Configuration menu from the drop-down menus on the left of the screen, finally access the Web Server menu and select either Non-Secure or Secure Browser Access. The system defaults to Secure, so the first-time login must be done with https.

3. Log into the WebUI using the appropriate Username and Password.
4. From the menu on the left, select **CP MEF**, then click **Unlock**.
5. Confirm user presence with button on the front of the CPU module, click **OK** on the pop-up window, then select **Browse** to locate the desired file.
6. Once the correct file is selected, click the **Update** button (located next to the **Unlock** button).
7. The uploading status will show until complete. Once complete the message **MEF file uploaded successfully** will display.

B.3 –Replace VLP MEF on CPU III via USB drive

Perform the following actions:

1. Insert USB Drive in USB slot on front of Display.
2. If Maintainer security has been enabled, enter the password. The password is case sensitive. If security is not enabled, proceed to step 3.
3. Connect an Ethernet cable between the Laptop port on the Display and the Laptop port of the CPU III module.
4. From the USB menu Select **1) Software Updates > 3) CPU-III Update**.
5. Verify that the Ethernet cable is well seated on both ends.
6. Select **2) Update VLP MEF**.
7. When asked by the Setup program to Erase the MEF, select **1) Yes**.
8. The **Select File** window opens.
9. Scroll down to select the file to be installed, in this example VPH03_30.MEF. Select **Enter**.
10. The new MEF begins loading. This may take a few minutes. While the file is uploading, progress will be indicated on the bottom line of the window.

11. When complete, the Display text provides all of the module update options. Select **0) Exit Setup**.
12. The Upload to System window opens and states:
Exit software finished rebooting the module.
13. Press the **Back** button.

B.4 – Replace VLP MEF on CPU III via WebUI

1. Locate the IP address of the GCP 4000 unit via the selector buttons on the front of the CPU III unit. Type into a compatible web browser with https:// in front of it.
2. Login to the WebUI using the appropriate Username and Password.
3. From the menu on the left, select **VLP MEF**, then click **Unlock**.
4. Confirm user presence with button on the front of the CPU III module, click **OK**, then select **Browse** and locate the desired file.
5. Click the **Update** button located next to the **Unlock** button.
6. The uploading status will show until complete. Once complete, the message **MEF file uploaded successfully** will display.

B.5 – Change the MCF on CPU III via USB

Perform the following actions:

1. Insert USB Drive in USB slot on front of Display.
2. If Maintainer security has been enabled, enter the password. The password is case sensitive. If security is not enabled, proceed to step 3.
3. Connect an Ethernet cable between the Laptop port on the Display and the Laptop port of the CPU III module.
4. From the USB menu Select **1) Software Updates > 3) CPU-III Update**.
5. Verify that the Ethernet cable is well seated on both ends.
6. Select **3) Update MCF**.
7. When asked by the Setup program to Erase the MCF Flash, select **1) Yes**.
8. The **Select File** window opens.
9. Scroll down to select the file to be installed, in this example GCP-T6X-02-5.mcf. Select **Enter**.
10. The new MCF begins loading. This may take a few minutes. While the file is downloading, progress will be indicated on the bottom line of the window.

NOTE

After the progress bar reaches 100% and stops, the CPU loads a copy of the file to the ECD on the chassis. This will be indicated on the Display screen by the field turning to a grey background and on the 4-character display on the CPU as DOWNLOADING MCF then COPYING MCF TO ECD. Wait until this process completes and the text field has a black background before proceeding, 4-character display shows SETUP.

B.6 – Change the MFCRC on CPU III via USB

1. Select **1) Change MFCRC**.
2. The **Enter MCF CRC for GCP** window opens.
3. Use the back arrow to clear the number that appears in the window, then use the keypad to enter the CRC issued with the software revision instructions. The CRC will always be 8 characters consisting of 0 through 9 and A through F. Once the number has been entered and verified correct, select **Enter**.
4. When complete, the Display text provides all of the module update options. Select **0) Exit Setup**. The **Upload to System** window opens and states: Exit software finished rebooting the module.
5. Press the Back button. Select **0) Exit View**.

B.7 – Change the MCF on CPU III via WebUI

1. Locate the IP address of the GCP 4000 unit via the NAV and SEL buttons on the front of the CPU III unit. Type into a compatible web browser with https:// in front of it.
2. Login to the WebUI using the appropriate Username and Password.
3. From the menu on the left, select **VLP MCF**, then click **Unlock**.
4. Click the **Browse** button and select the correct file. (Note the MFCRC for entry into the **Enter MFCRC** field as well).
5. Select the **Update** button. Once the file has finished loading the message **MFCRC uploaded successfully and MCF file uploaded successfully**.

This completes **Installing Software on the CPU Card**.

C – Uploading Software onto Track Module

Per the instructions issued with the software revision, the next step is to install the GCP03_90.MEF files on the Track Modules.

- Track Module
 - a. DIAG Port – File: GCP03_90.MEF

Perform the following actions:

1. Insert USB Drive in USB slot on front of Display
2. Connect the serial cable between the Diag port on the Display and the DIAG (CP) port of the CPU module.
3. Select **1) Software Updates > 1) Module Updates**. The **Upload to System** window opens stating: Please check the serial cable connection before uploading. Press any key to continue.
4. Verify that the serial cable is well seated on both ends, then press any key. The Setup program begins loading.
5. Select 1) Change MEF.
6. When asked by the Setup program to **Erase the MEF?**, select **1) Yes**. The Select File window opens.
7. Scroll down to select the file to be installed, in this example GCP03_90.MEF. Select Enter.
8. The new MEF begins loading. This may take a few minutes. While the file is downloading, progress will be indicated on the bottom line of the window.
9. When complete, the Display text provides options to Change the MCF or Exit Setup. Select **0) Exit Setup**. The **Upload to System** window opens and states: **Exit software finished rebooting the module**.
10. Press the **Back** button. Select **0) Exit View**.
11. Repeat the procedure for the remaining Track Modules in the MAIN section of the GCP.

D – Uploading Software onto PSO Module

Per the instructions issued with the software revision, the next step is to install the GPP00_40.MEF files on the PSO Modules.

- PSO Module
 - DIAG Port – Master File: GPP00_40.MEF

Perform the following actions:

1. Insert USB Drive in USB slot on front of Display
2. Connect the serial cable between the Diag port on the Display and the DIAG (CP) port of the CPU module.
3. Select **1) Software Updates > 1) Module Updates**. The **Upload to System** window opens stating: Please check the serial cable connection before uploading. Press any key to continue.
4. Verify that the serial cable is well seated on both ends, then press any key. The Setup program begins loading.
5. Select 1) Change MEF.

6. When asked by the Setup program to **Erase the MEF?**, select **1) Yes**. The Select File window opens.
7. Scroll down to select the file to be installed, in this example GPP00_40.MEF. Select Enter.
8. The new MEF begins loading. This may take a few minutes. While the file is downloading, progress will be indicated on the bottom line of the window.
9. When complete, the Display text provides options to Change the MCF or Exit Setup. Select **0) Exit Setup**. The **Upload to System** window opens and states: **Exit software finished rebooting the module**.
10. Press the **Back** button. Select **0) Exit View**.
11. Repeat the procedure for the remaining PSO Modules in the MAIN section of the GCP.

E – Uploading Software onto RIO Module

Per the instructions issued with the software revision, the next step is to install the RIO01_07.MEF files on the Track Modules.

- RIO Module
 - DIAG Port – File: RIO01_07.MEF

Perform the following actions:

1. Insert USB Drive in USB slot on front of Display
2. Connect the serial cable between the Diag port on the Display and the DIAG (CP) port of the CPU module.
3. Select **1) Software Updates > 1) Module Updates**. The **Upload to System** window opens stating: Please check the serial cable connection before uploading. Press any key to continue.
4. Verify that the serial cable is well seated on both ends, then press any key. The Setup program begins loading.
5. Select 1) Change MEF.
6. When asked by the Setup program to **Erase the MEF?**, select **1) Yes**. The Select File window opens.
7. Scroll down to select the file to be installed, in this example RIO01_07.MEF. Select Enter.
8. The new MEF begins loading. This may take a few minutes. While the file is downloading, progress will be indicated on the bottom line of the window.
9. When complete, the Display text provides options to Change the MCF or Exit Setup. Select **0) Exit Setup**. The **Upload to System** window opens and states: **Exit software finished rebooting the module**.
10. Press the **Back** button. Select **0) Exit View**.
11. Repeat the procedure for the remaining RIO Modules in the MAIN section of the GCP.
12. Repeat the above procedures for installing all files on the STANDBY modules.

F – Uploading Software onto SSCC Illi Module

If the instructions issued with the software revision, call for upgrading the software in the SSCC Illi Module, the next step is to install the specified MEF file on the SSCC modules.

The SSCC Modules have a master processor that controls slave processors, which control the independent lamp outputs. Therefore, there are separate MEFs for the master and slave processors.

- SSCC Illi Module
 - DIAG Port – File: XNG04_00.MEF
 - DIAG Port – Slave File: 9V816A01.C

Perform the following actions:

NOTE

Selecting **1) Change App Code** will change Application Code, which on the SSCC are MEF files. When loading software for Master/Slave operations, “Master” loads the MEF on the Master processor and “All Slaves” loads the MEF on the slave processors.

Currently, Slave software must be installed using the Display Terminal (DT). Refer to GCP 4000 Field Manual, SIG-00-08-10, page 130 for the procedures to load SSCC Illi slave software using the DT software.

Perform the following actions:

1. Insert USB Drive in USB slot on front of Display
2. Connect the serial cable between the Diag port on the Display and the DIAG (CP) port of the CPU module.
3. Select **1) Software Updates > 1) Module Updates**. The **Upload to System** window opens stating: Please check the serial cable connection before uploading. Press any key to continue.
4. Verify that the serial cable is well seated on both ends, then press any key. The Setup program begins loading.
5. Select 1) Change App Code.
6. Select 1) Change Master.
7. Scroll down to select the file to be installed, in this example XNG04_00.MEF. Select Enter.
8. The new MEF begins loading. This may take a few minutes. While the file is downloading, progress will be indicated on the bottom line of the window.
9. When complete, the Display text provides options to Change the MCF or Exit Setup. Select **0) Exit Setup**. The **Upload to System** window opens and states: **Exit software finished rebooting the module**.
10. Press the **Back** button. Select **0) Exit View**.
11. Connect the serial cable to the second SSCC Illi unit and repeat steps 1 – 13 above.

⚠ WARNING

WHEN LOADING SOFTWARE INTO ONE OF THE TWO SLAVE PROCESSORS, THE LIGHT FOR THE PROCESSOR UNDERGOING A SOFTWARE UPGRADE (L1 OR L2) WILL NOT FLASH, BUT THE LIGHT ON THE OTHER PROCESSOR WILL CONTINUE TO FLASH.

Refer to the NOTE above to load slave software.

G – Uploading Software onto Display Module

Per the instructions issued with the software revision, the next step is to install the Non-Vital MEF files on the A80485-1 Display Module.

- Display Module
 - USB Port – File:
NG5K_MEF_1.0.23R.TGZ

Perform the following actions:

1. Insert USB Drive in USB slot on front of Display
2. Select 1) Software Updates > 2) Display Executive Update.
3. The Select File window opens. Select the correct file to load, in this example NG5K_MEF_1.0.23R.TGZ.. Select Enter.
4. The **Upload NV Executive** window opens, stating: **Please wait. Request sent to Executive...** The new MEF begins loading. This may take a few minutes. While the file is downloading, progress will be indicated on the bottom line of the window.
5. When complete, the Upload to NV Executive window opens and states: Uploaded NV Executive. Press Enter to Reboot OR Back to Reboot later.
6. Select **Enter**. The Display reboots.
7. Press the **Back** button. Select **0) Exit View**.

H – Transfer Card, A80406 or A80468.

The Transfer Card software is not field upgradable and software changes are performed at the factory.

CONFIGURATION FILE ACTIVITY USING USB DEVICE

A – Download Configuration File To USB Drive

Perform the following actions:

1. Insert USB Drive in USB slot on front of Display
2. Select 3) Download Configuration. The Download configuration window opens, stating: Downloading PAC File....Please do not Remove USB
3. When the file has downloaded from the Display to the USB Drive, the PAC File Download window opens, stating: Download Completed. File is saved at (the actual file location on the USB Drive). Press any key to continue.

WARNING

UPLOADING A NEW CONFIGURATION, MEF, OR MCF WILL PLACE THE GCP IN A RESTRICTIVE STATE AND ACTIVATE THE CROSSING WARNING SYSTEM.

WHEN USING MCF GCP-T6X-01-2.MCF OR EARLIER GATES WILL BEGIN TO LOWER IMMEDIATELY (WITH GATE DELAY).

BEFORE UPLOADING BEGINS, TAKE ADEQUATE PRECAUTIONS TO WARN ANY PEDESTRIANS, PERSONNEL, TRAINS, AND VEHICLES IN THE AREA UNTIL PROPER SYSTEM OPERATION IS VERIFIED.

CAUTION

To minimize the time that signals are in a restrictive state, if the existing configuration needs to be saved, save it prior to selecting “upload configuration” from the USB wizard menu.

B – Upload Configuration File To GCP

Perform the following actions:

1. Insert USB Drive in USB slot on front of Display

NOTE

Selecting the BACK button on the Save Configuration window skips saving the current configuration, but does continue with the process of uploading the new configuration

3. The Save Configuration window opens, stating: Do you want to save current configuration? Press Back to cancel request Or Enter to continue.
4. Select Enter. The **Download configuration** window opens, stating: **Downloading PAC File....Please do not Remove USB.** This may take a few minutes. While the file is downloading, progress will be indicated on the bottom line of the window.
5. When the file has downloaded from the Display to the USB Drive, the PAC File Download window opens, stating: Download Completed. File is saved at (the actual file location on the USB Drive). Press any key to continue.
6. The **Select File** window opens. Scroll down to select the correct PAC file. Select **Enter**. The **Upload Configuration** window opens, stating **Saving configuration.**
7. The **Save** window opens, stating: **Press the SEL or NAV button and then select Enter to save parameters.** The File name, Site Name, SIN, and CCN data then appear, followed by : **Do you want to save the parameters?** Press the SEL or NAV buttons on the CPU Card and then select **Enter**.
8. The Upload configuration window opens, stating: System will now reboot to load the new settings. Press Any Key to Continue.

B.1 - Checking the OCCN

After uploading a new Configuration (PAC file), check the OCCN as follows:

1. Scroll to Diags & Reports menu.

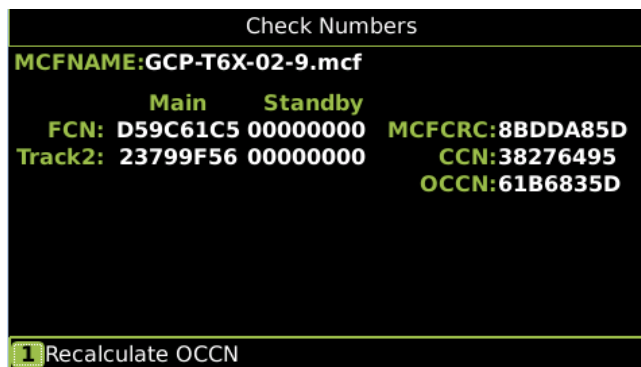

- 3.
4. If window indicates the OCCN is out of date as shown below, press 1 to recalculate the OCCN and the value will be updated.

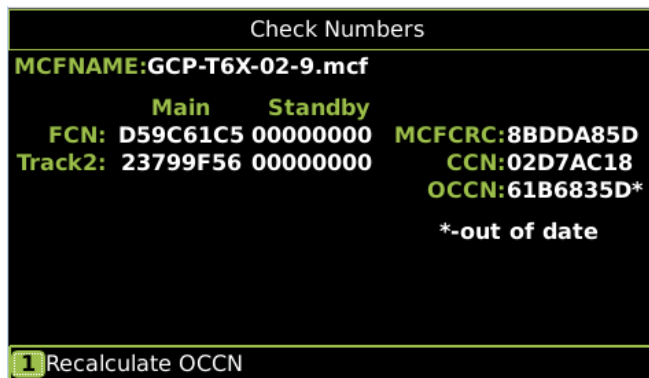

5. **1** Recalculate OCCN
Verify that the OCCN matches the one on the site plans

DOWNLOADING REPORTS AND LOGS

Insert the USB drive in the USB port on the Display Module to automatically open the **USB** window.

A **USB Detected** window opens, stating USB detected. Press **Back** to continue or **Enter** for USB Menu. The USB window opens. This menu may be returned to at any time by pressing the **Back** button, providing the USB drive is still inserted in the port.

A – Download Configuration Report

To download the Configuration Report to the USB drive:

1. From the **USB** menu, select **2) Download Configuration Report**, The **USB** window states the operation **Retrieve Configuration Rpt** with the Status **In Progress**. The message **Saving Data, Do Not Remove USB** will appear across the bottom of the window.
2. When the report has downloaded, the Status message changes to **Complete**.
3. Select **Back** to return to the **USB** menu.

B – Download GCP Logs

Select **5) Download GCP Logs** to download one of the GCP Logs:

- Status Log
- Summary Log
- Maintenance Log

B.1 – Download Status Log

1. Select **1) Download Status Log**. The Select Card window opens displaying the list of all active Cards:
 - Slot 1 – CP
 - Slot 1 – VLP2
 - Slots 2 through 7 – Track, PSO, or RIO
 - Slot 8 – SSCC IIIi
 - Slot 9 – SSCC IIIi
2. Scroll down to select the desired card for the Status Log. The Download GCP Status Log window opens, stating Downloading GCP Status Logs.... Please do not remove USB. No. of Events NNN>

3. When complete, the window states Download completed. File saved at (entire path and file name provided). Press any key to Continue.
4. Press any key. The menu returns to depict the Status, Summary, and Maintenance Log choices.

B.2 – Download Summary Log

1. Select **2) Download Summary Log**. The Select Card window opens displaying the list of all active Cards:
 - Slot 1 – CP
 - Slot 1 – VLP2
 - Slots 2 through 7 – Track, PSO, or RIO
 - Slot 8 – SSCC IIIi
 - Slot 9 – SSCC IIIi
2. Scroll down to select the desired card for the Status Log. The Download GCP Log window opens, stating Downloading GCP Summary Logs.... Please do not remove USB. No. of Events NNN>
3. When complete, the window states Download completed. File saved at (entire path and file name provided). Press any key to Continue.
4. Press any key. The menu returns to depict the Status, Summary, and Maintenance Log choices.

B.3 – Download Maintenance Log

1. Select 3) Download Maintenance Log.
2. The **USB** window states the operation **Download Maintenance Log** with the Status **In Progress**. The message **Saving Data, Do Not Remove USB** will appear across the bottom of the window.
3. When the report has downloaded, the Status message changes to **Complete**.
4. Select **Back** to return to the **USB** menu.

C – Download Train History

1. Select 6) Download Train History.
2. The Download GCP Train History window opens, stating Downloading GCP Status Logs.... Please do not remove USB. No. of Events NNN>
3. When complete, the window states Download completed. File saved at (entire path and file name provided). Press any key to Continue.

NOTE

Current software configuration requires installing a serial cable with a null modem adapter between the A80485-1 Display's DIAG connector and the USER connector on the SEAR Ili.

A – Installing Software on SEAR Ili Module

Per the instructions issued with the software revision, the next step is to install the 9V725-A01Aa.BIN files on the SEAR Ili Module.

- SEAR Ili Module
 - USER Port – Master File: 9V725-A01Aa.BIN

Perform the following actions:

1. Insert USB Drive in USB slot on front of Display
2. Connect the serial cable between the Diag port on the Display and the DIAG (CP) port of the CPU module.
3. Select **7) SEAR Transfers > 1) Upload Executive**. The **Select File** window listing the possible software files of type .BIN.
4. Scroll down to select the file to be installed, in this example **9V725-A01Aa.BIN**.
5. The **Upload Executive** window opens, stating: **Please wait. Request sent to Executive...** The new .BIN file begins loading. This may take a few minutes. While the file is downloading, progress will be indicated on the bottom line of the window.
6. When complete, the Upload to System window opens and states: Successful. Press any key to Exit USB Menu Screen.
7. Reprogram SEAR per the site plan to return the SEAR to fully operational state.

B – CDL File Operations

Perform the following actions:

1. Insert USB Drive in USB slot on front of Display
2. Select **7) SEAR Transfers > 2) Upload CDL**. The **Select File** window listing the possible software files of type .CDL.
3. Scroll down to select the file to be installed, in this example **9V864-A01P.CDL**.
4. The **Upload Executive** window opens, stating: **Please wait. Request sent to Executive...** The new CDL begins loading. This may take a few minutes. While the file is downloading, progress will be indicated on the bottom line of the window.
5. When complete, the Upload to System window opens and states: Successful. Press any key to Exit USB Menu Screen.
6. Reprogram SEAR per the site plan to return the SEAR to fully operational state.

C – Download SEAR Logs and Reports

There are multiple SEAR Logs available for download:

- Download CDL Log
- Download Application Log
- Download Standard Log
- Download System Log
- Download Incident Report

C.1 – Download CDL Log

1. Insert USB Drive in USB slot on front of Display
2. If Maintainer or Supervisor security has been enabled, enter the password. The password is case sensitive. If security is not enabled, proceed to step 3.
3. Connect the serial cable between the Diag port on the Display and the DIAG (CP) port of the SEAR III module.
4. Select 8) SEAR Transfers > 4) Download CDL Log. The Download CDL Log screen opens, and states In Progress. The In Progress changes to Complete when the download is complete. The file is saved as CDL_LOG_YYYYMONDD-N.TXT.
5. Select **BACK** twice.

C.2 – Download Application Log

There are four options for available for downloading the Application Log:

- Capture Last 24 Hours of Application Logs
- Capture Last 2 Weeks of Application Logs
- Capture All Application Logs
- Capture Application Logs by Date & Time

Capture Last 24 Hours of Application Logs

1. Insert USB Drive in USB slot on front of Display
2. If Maintainer or Supervisor security has been enabled, enter the password. The password is case sensitive. If security is not enabled, proceed to step 3.
3. Connect the serial cable between the Diag port on the Display and the USER port of the SEAR III module.
4. Select 8) SEAR Transfers > 5) Download Application Log > 1) Capture Last 24 Hours of Application Logs. The Retrieve 24 Hr. App Logs screen opens, and states In Progress. The In Progress changes to Complete when the download is complete. The file is saved as SEAR_APP_YYYYMONDD TO YYYYMONDD.TXT
5. Select **BACK** three times.

Capture Last 2 Weeks of Application Logs

1. Insert USB Drive in USB slot on front of Display
2. If Maintainer or Supervisor security has been enabled, enter the password. The password is case sensitive. If security is not enabled, proceed to step 3.

3. Connect the serial cable between the Diag port on the Display and the USER port of the SEAR Ili module.
4. Select 8) SEAR Transfers > 5) Download Application Log > 2) Capture Last 2 Weeks of Application Logs. The Retrieve 2 Week App Logs screen opens, and states In Progress. The In Progress changes to Complete when the download is complete. The file is saved as SEAR_APP_YYYYMONDD TO YYYYMONDD.TXT
5. Select **BACK** three times.

Capture All Application Logs

1. Insert USB Drive in USB slot on front of Display
2. If Maintainer or Supervisor security has been enabled, enter the password. The password is case sensitive. If security is not enabled, proceed to step 3.
3. Connect the serial cable between the Diag port on the Display and the USER port of the SEAR Ili module.
4. Select 8) SEAR Transfers > 5) Download Application Log > 2) Capture All Application Logs. The Retrieve All App Logs screen opens, and states In Progress. The In Progress changes to Complete when the download is complete. The file is saved as SEAR_APP_1969Dec31 To YYYYMONDD.TXT
5. Select **BACK** three times.

Capture Application Logs By Date & Time

1. Insert USB Drive in USB slot on front of Display
2. If Maintainer or Supervisor security has been enabled, enter the password. The password is case sensitive. If security is not enabled, proceed to step 3.
3. Connect the serial cable between the Diag port on the Display and the USER port of the SEAR Ili module.
4. Select 8) SEAR Transfers > 5) Download Application Log > 2) Capture All Application Logs. The Application Log Filter screen opens
5. Scroll using the arrows to select the Start Date, Start Time, End Date, & End Time of the Application Log to be captured. Scroll to **Download**. Select **Download**.
6. The **Retrieve Date/Time App Logs** screen opens and states **In Progress**. The **In Progress** changes to **Complete** when the download is complete. The file is saved as **SEAR_APP_YYYYMONDD TO YYYYMONDD.TXT**
7. Select **BACK** three times.

C.3 – Download Standard Log

There are four types of Standard Log available for download:

- Capture Last 24 Hours of Standard Logs
- Capture Last 2 Weeks of Standard Logs
- Capture All Standard Logs
- Capture Standard Logs by Date & Time

Capture Last 24 Hours of Standard Logs

1. Insert USB Drive in USB slot on front of Display
2. If Maintainer or Supervisor security has been enabled, enter the password. The password is case sensitive. If security is not enabled, proceed to step 3.
3. Connect the serial cable between the Diag port on the Display and the USER port of the SEAR Ili module.
4. Select 8) SEAR Transfers > 5) Download Standard Log > 1) Capture Last 24 Hours of Standard Logs. The Retrieve 24 HR Std Logs screen opens, and states In Progress. The In Progress changes to Complete when the download is complete. The file is saved as SEAR_EVT_YYYYMONDD TO YYYYMONDD.TXT
5. Select **BACK** three times.

Capture Last 2 Weeks of Standard Logs

1. Insert USB Drive in USB slot on front of Display
2. If Maintainer or Supervisor security has been enabled, enter the password. The password is case sensitive. If security is not enabled, proceed to step 3.
3. Connect the serial cable between the Diag port on the Display and the USER port of the SEAR Ili module.
4. Select 8) SEAR Transfers > 5) Download Standard Log > 2) Capture Last 2 Weeks of Standard Logs. The Retrieve 2 Week Std Logs screen opens, and states In Progress. The In Progress changes to Complete when the download is complete. The file is saved as SEAR_EVT_YYYYMONDD TO YYYYMONDD.TXT
5. Select **BACK** three times.

Capture All Standard Logs

1. Insert USB Drive in USB slot on front of Display
2. If Maintainer or Supervisor security has been enabled, enter the password. The password is case sensitive. If security is not enabled, proceed to step 3.
3. Connect the serial cable between the Diag port on the Display and the USER port of the SEAR Ili module.
4. Select 8) SEAR Transfers > 5) Download Standard Log > 2) Capture All Standard Logs. The Retrieve All Std Logs screen opens, and states In

Progress. The In Progress changes to Complete when the download is complete. The file is saved as SEAR_APP_1969Dec31 To YYYYMONDD.TXT

5. Select **BACK** three times.

Capture Standard Logs By Date & Time

1. Insert USB Drive in USB slot on front of Display
2. If Maintainer or Supervisor security has been enabled, enter the password. The password is case sensitive. If security is not enabled, proceed to step 3.
3. Connect the serial cable between the Diag port on the Display and the USER port of the SEAR Ili module.
4. Select 8) SEAR Transfers > 6) Download Standard Log > 2) Capture All Standard Logs. The Standard Log Filter screen opens
5. Scroll using the arrows to select the Start Date, Start Time, End Date, & End Time of the Standard Log to be captured. Scroll to **Download**. Select **Download**.
6. The **Retrieve Date/Time App Logs** screen opens and states **In Progress**. The **In Progress** changes to **Complete** when the download is complete. The file is saved as **SEAR_EVT_YYYYMONDD TO YYYYMONDD.TXT**
7. Select **BACK** three times.

C.4 – Download System Log

1. Insert USB Drive in USB slot on front of Display
2. If Maintainer or Supervisor security has been enabled, enter the password. The password is case sensitive. If security is not enabled, proceed to step 3.
3. Connect the serial cable between the Diag port on the Display and the USER port of the SEAR Ili module.
4. Select 8) SEAR Transfers > 7) Download System Log. The Download System Log screen opens, and states In Progress. The In Progress changes to Complete when the download is complete. The file is saved as SEAR_SYSLOG_YYYYMONDD-N.TXT.
5. Select **BACK** twice.

C.5 – Download Incident Report(s)

1. Insert USB Drive in USB slot on front of Display
2. If Maintainer or Supervisor security has been enabled, enter the password. The password is case sensitive. If security is not enabled, proceed to step 3.
3. Connect the serial cable between the Diag port on the Display and the USER port of the SEAR Ili module.

4. Select 8) SEAR Transfers > 8) Download Incident Report(s). The Download Incident Report(s) screen opens, and states In Progress. The In Progress changes to Complete when the download is complete. The files are saved as INC_456123A_YYYYMONDD-slot0.TXT
INC_456123A_YYYYMONDD-slot1.TXT, etc.
5. Select **BACK** twice.

D –EZ And EX Value Recording

The A80485-1 Display may record and download EZ and EX history data. Unlike the A80407-3 Display Module, EZ and EX data may be recorded without the presence of a USB Drive.

D.1 – Real Time Recording of EZ and EX Values

1. Scroll to the Program View menu and select 1)Display Programming > 2) Log Setup. The Disp Log Setup window opens.
2. Scroll down to the **EZ/EX Recording** parameter and select **Enter**. The **EZ/EX Recording** window opens.
3. Scroll down to **Enabled**, select **Enter**.

D.2 – Using Recorded EZ and EX Files

The recorded values are stored in a .csv file that can be reviewed and graphed in Microsoft® Excel®. To view .csv files open Microsoft Excel.

- Select File \Open.
- On the Open window, select 'Text files (*.prn; *.txt; *.csv)' in the Files of type: field.
- Type of select the file name to be viewed.
- Press **Open**.

The file data appears in columns similar to the figure below.

	A	B	C	D	E	F	G	H
1	Count	DateTime	T1 Ez	T1 CheckE	T1 Ex	T1 Isl Occ	T1 Prime	AND1 XR
2	0	#####	99	99	93	125	140	155
3	1	#####	99	99	93	125	140	155
4	2	#####	99	99	93	125	140	155
5	3	#####	99	100	93	125	140	155
6	4	#####	100	99	93	125	140	155
7	5	#####	85	91	98	125	140	155
8	6	#####	81	97	99	125	140	155
9	7	#####	93	94	93	125	140	155
10	8	#####	93	92	93	125	140	155
11	9	#####	92	90	93	125	140	155
12	10	#####	90	88	93	125	140	155
13	11	#####	87	85	93	125	140	155

D02162007_0226
2-16-07

Figure 17: Data File Layout Example

Select a column to graph by clicking on the column header (A through H in the figure above).

To select multiple columns, click the first column header then hold down the Ctrl key and click the additional column headers. Columns C, E and G selected in the figure above. Select **Insert \Chart \ Line Chart**. Select a chart sample and then click **Finish**.

A chart similar to the one below is displayed.

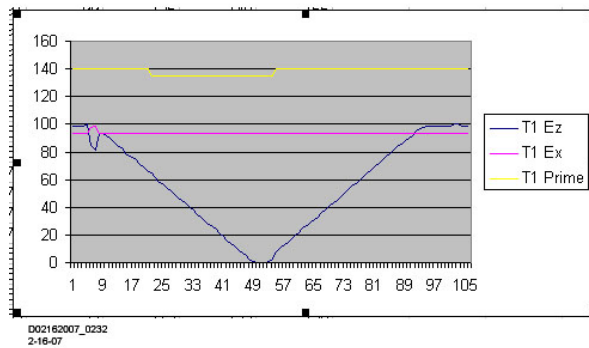

Figure 18: Prime, EZ, and EX Chart Example

APPENDIX A – HARDWARE

CHASSIS CONFIGURATIONS

Common Chassis Components

The various 4000 GCP chassis encountered in the field will have the following similarities (see Figure 19):

- Echelon connector location
- Chassis diagnostic port location, same as the DIAG (CP) port of the active CPU in dual units
- Battery/CPU interface connector location
- CPU Module connector location (left most card slot)
- CIC (Chassis Identification Chip) location
- ECD (External Configuration Device) location
- Grounding strap location

NOTE

The keyed interface connectors used on the 4000 GCP front panel consist of both screw-down type and cage-clamp type connectors. Refer to page 16 for wire preparation and insertion instructions.

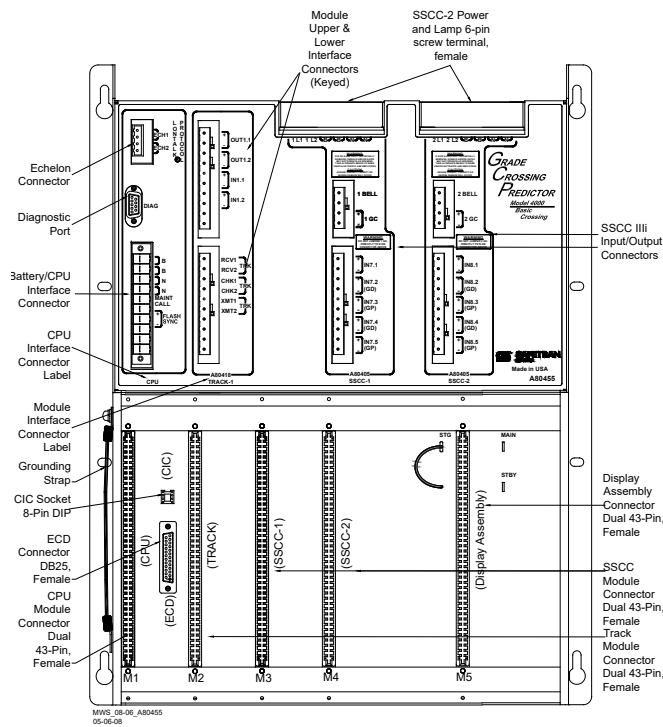

Figure 19: Common Chassis Component Locations

Track Card Compatibility

⚠ WARNING

IF ANY GCP TRACK CIRCUIT HAS AN ACTIVE INTERNAL ISLAND, THE GCP 4000 CHASSIS MUST HAVE FERRITE BEADS INSTALLED ON THE TRACK XMT AND RCV WIRES AS DESCRIBED IN APPENDIX A INSTALLATION OF FERRITE BEADS IN ORDER TO AVOID POSSIBLE SHUNTING ISSUES IF A REV D OR EARLIER A80418 TRACK MODULE IS INSTALLED IN CHASSIS.

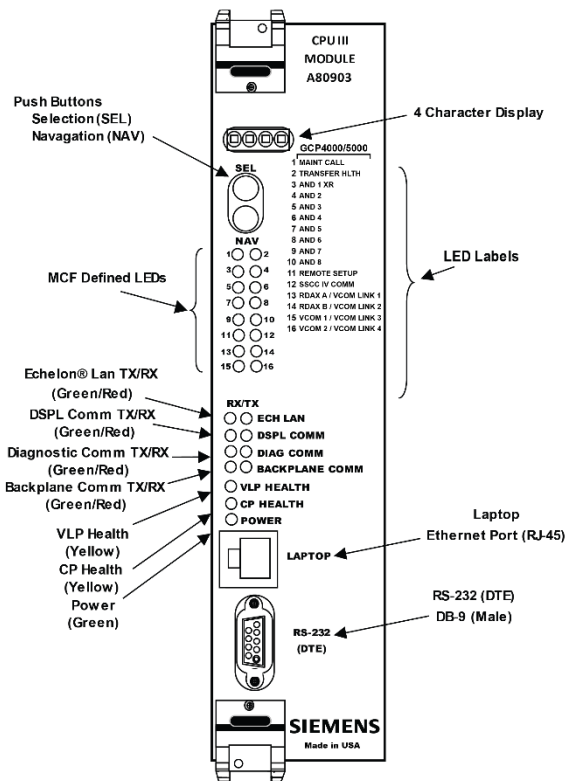
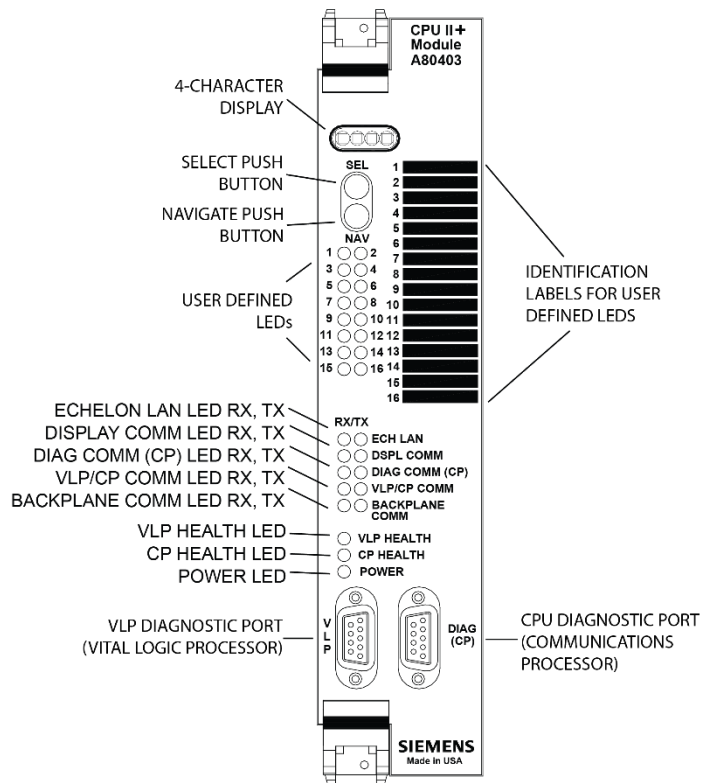

Figure 21: Central Processing Unit (CPU III) Module, A80903

Table 38: CPU Module LED Descriptions

LED		Function	Description
Name	Color		
1 MAINT CALL	Red	Maintenance Call See page 81	On – maintenance call output on Off - maintenance call output off
2 TRANSFER HEALTH	Red	Transfer Output See page 82	On – transfer signal is being generated transfer card should not be counting down Off – transfer signal is not being generated If transfer card is in AUTO it should be counting down
3 AND 1 XR	Red	AND 1 XR	On – AND 1 XR is energized Off – AND 1 XR is De-energized
4 to 10 AND 2 through AND 8	Red	AND 2 through AND 8	On – AND is Energized Off – AND is De-energized or Not Used
11 REMOTE SETUP	Red	Remote Setup Session	On – The GCP has been primed for a remote one-person setup (see Appendix F) Flashing – Remote setup in progress Off – No remote setup is in progress
12 SSCC IV COMM	Red	SSCCIV Echelon Active	On – External SSCC IV Echelon is in session Off – External SSCC IV Echelon not used or not in session
13 RADIO DAX LINK A	Red	Radio DAX Link A	On – Radio DAX Link A is in session Off – Radio DAX Link A not used or not in session
14 RADIO DAX LINK B	Red	Radio DAX Link B	On – Radio DAX Link B is in session Off – Radio DAX Link B not used or not in session
15 VITAL COMM1	Red	Vital Comm 1	On – Vital Comm1 is in session
16 VITAL COMM2	Red	Vital Comm 2	On – Vital Comm2 is in session
ECH LAN RX	Grn	Echelon Message Received	Flashes when the CPU is receiving an ATCS message via the Echelon LAN.

LED		Function	Description
Name	Color		
ECH LAN TX	Red	Echelon Message Sent	Flashes when the CPU is transmitting an ATCS message via the Echelon LAN.
DSPL COMM RX	Grn	Display Port Message Received	Flashes when the CPU is receiving data from the display module.
DSPL COMM TX	Red	Display Port Message Sent	Flashes when the CPU is sending data to the display module.
DIAG COMM (CP) RX	Grn	Diag Port Message Received	Flashes when the CPU is receiving data from the communications processor diagnostic (DIAG CP) serial port.
DIAG COMM (CP) TX	Red	Diag Port Message Sent	Flashes when the CPU is transmitting data on the communications processor diagnostic (DIAG CP) serial port.
VLP/CP COMM RX (CPU II+ Only)	Grn	Comm Message Received	Flashes when the VLP is receiving data from the CP.
VLP/CP COMM TX (CPU II+ Only)	Red	Comm Message Sent	Flashes when the VLP is transmitting data to the CP.
BACK-PLANE COMM RX	Grn	Backplane Message Received	Flashes when the VLP is receiving data from the serial bus.
BACK-PLANE COMM TX	Red	Backplane Message Sent	Flashes when the VLP is sending data onto the serial bus.
VLP HEALTH	Yel	VLP Health Status	<ul style="list-style-type: none"> Flashes slowly (1Hz) when the CPU VLP is functioning normally. Flashes fast (4Hz) when the VLP is unhealthy.
CP HEALTH	Yel	CP Health Status	Flashes slowly (1Hz) when the CP is functioning normally.
POWER	Grn	Power Indication	On steadily when power is applied to the module.

Table 39: CPU Module Display Messages

Display	Mode	Meaning	System State
MCF Name; e.g. GCP-T6X-02-1	Scrolling	VLP is healthy	CPU is healthy.
BOOT	Steady	CPU is booting up.	CPU is booting up. Crossing is activated.
CRC*	Steady	MCF CRC is incorrect for the current MCF	Entered CRC does not match CRC of MCF. Crossing is activated.
MCF*	Steady	CPU is not healthy because the MCF is not valid.	Reboot CPU or reload MCF. Crossing is activated.
SIN*	Steady	Site Identification Number is invalid.	Enter valid SIN. Crossing is activated.
VLP UCFG	Scrolling	VLP is unconfigured.	No comm to I/O modules. Crossing is activated.
VLP INITIAL	Scrolling	The CP is transferring the configuration from NVRAM to the VLP.	No comm to I/O modules. Crossing is activated.
CMCF / *MCF	Scrolling	The CP is copying the MCF from the ECD into flash memory.	No comm to I/O modules. Crossing is activated.
NO VLP COMMS	Scrolling	The CP is not communicating with the VLP. VLP could be rebooting or performing its initial configuration checks	No comm to I/O modules. Crossing is activated.
IP Address (CPU III Only)	Scrolling	Select button can be used to toggle between CP, VLP, and IP address.	CPU is healthy
EFLA	Steady	Erasing its flash memory in preparation for copying the	No comm to I/O modules. Crossing is

Display	Mode	Meaning	System State
		MCF from the ECD into flash memory.	activated.
ADR*	Steady	The radio DAXing neighbor ATCS address is invalid	Address of DAX session cannot be computed. Enter valid SIN
INI*	Steady	Rebooting	System Reboot - Crossing is activated.
Exxx	Steady	Internal error, System will reboot. xxx is 3 digit hex number	Reload MCF - Crossing is activated.
LMCF	Steady	Rebooting	System Reboot - Crossing is activated.
ICHK	Steady	Rebooting	System Reboot - Crossing is activated.

Note: Steady messages may alternate with other messages
The CPU has two processors: the Communications Processor (CP) and the Vital Logic Processor (VLP). When new software is installed into the CP, the VLP continues running without interruption until the CP setup is complete. This means that if the GCP 4000 system is healthy and the crossing is not active, the VLP continues to correctly control the crossing while the new software installation into the CP is in progress. However, while the software transfer is in progress, the CP is not capable of logging state changes or communicating to the SEAR Ili.

Table 40: Setup Menu Display

Indication	Mode	Meaning
DOWNLOAD-ING SETUP	Scrolls	The setup program is being downloaded into the CP.
SETUP	Scrolls	The CP is in setup mode, i.e., MCF, MCF CRC, or CP MEF is being changed.
WAIT	Steady	CP is erasing flash memory.
WAITING FOR MEF	Scrolls	CP is waiting for a new MEF.
DOWNLOAD-ING MEF	Scrolls	A new MEF is being downloaded into the CP.
WAITING FOR MCF	Scrolls	CP is waiting for a new MCF.
DOWNLOAD-ING MCF	Scrolls	A new MCF is being downloaded into the CP.
DONE	Steady	Setup mode is ending.
BOOT	Steady	The CP is rebooting.

TRACK MODULE USER INTERFACE (A80418)

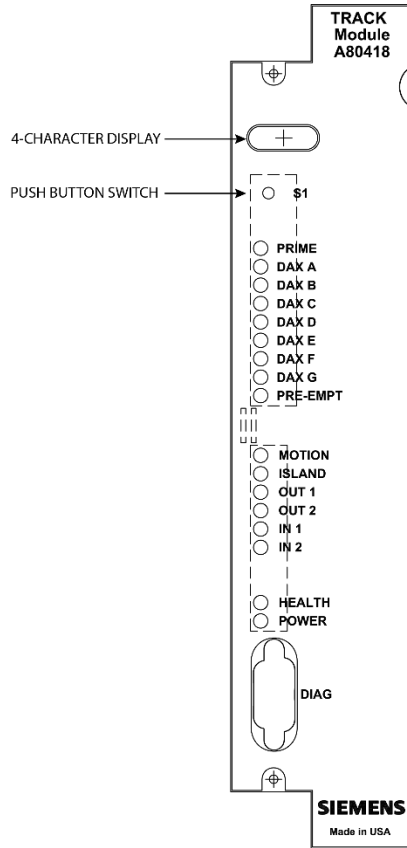

Figure 22: Track Module, A80418

Table 41: Track Module LED Descriptions

LEDs		DESCRIPTION
NAME	COLOR	
PRIME	Red	On – Prime predictor is energized Off – Prime predictor is de-energized or not used Flashing - Prime predictor is running the programmed pickup delay
DAX A	Red	On – DAX A predictor is energized Off – DAX A predictor is de-energized or not used Flashing – DAX A predictor is running its pickup delay
DAX B	Red	On – DAX B predictor is energized Off – DAX B predictor is de-energized or not used Flashing – DAX B predictor is running its pickup delay
DAX C	Red	On – DAX C predictor is energized Off – DAX C predictor is de-energized or not used Flashing – DAX C predictor is running its pickup delay
DAX D	Red	On – DAX D predictor is energized Off – DAX D predictor is de-energized or not used Flashing – DAX D predictor is running its pickup delay

Table 41: Track Module LED Descriptions

LEDs		DESCRIPTION
NAME	COLOR	
DAX E	Red	On – DAX E predictor is energized Off – DAX E predictor is de-energized or not used Flashing – DAX E predictor is running its pickup delay
DAX F	Red	On – DAX F predictor is energized Off – DAX F predictor is de-energized or not used Flashing – DAX F predictor is running its pickup delay
DAX G	Red	On – DAX G predictor is energized Off – DAX G predictor is de-energized or not used Flashing – DAX G predictor is running its pickup delay
PREEMPT	Red	On – Preempt predictor is energized Off – Preempt predictor is de-energized or not used Flashing – Preempt predictor is running its pickup delay
MOTION	Red	On – GCP has not detected motion Flash – GCP has detected motion below motion threshold Off – GCP has detected motion
ISLAND	Red	On – Island is unoccupied Off – Island is occupied Flashing – Island is running its pickup delay
OUT 1	Red	On – output energized Off – output de-energized or failed
OUT 2	Red	On – output energized Off – output de-energized or failed
IN 1	Red	On – input energized Off – input de-energized or failed
IN 2	Red	On – input energized Off – input de-energized or failed
HEALTH	Yellow	Slow (1Hz) – module is healthy and communicating with CPU. Fast (2Hz) – module is healthy but not communicating with CPU. Very Fast (4Hz) – module is unhealthy and communicating with CPU.
POWER	Green	On steadily when power is applied to the module
Znnn	Red	Display alternates EZ Value where <i>nnn</i> is a 3-digit numeric value.
Xnnn	Red	Display alternates EX Value where <i>nnn</i> is a 3-digit numeric value.
Innn	Red	Display alternates Island Z Value where <i>nnn</i> is a 3-digit numeric value.

Table 41: Track Module LED Descriptions

LEDs		DESCRIPTION
NAME	COLOR	
*CAL	*CAL and GCAL or ICAL	GCP Calibration in progress

**Table 42:
Track Module Display Indications (Operational)**

Indication	Mode	Meaning	Module State
*APP	Switches between *APP and GAPP	GCP Approach calibration in progress	All predictors are de-energized
*LIN	Switches between *LIN and GLIN	GCP Linearization in progress.	All predictors are de-energized
ICAL	Blinks on and off	Island Calibration in progress	Island is de-energized

Table 43: Boot-up Messages

Indication	Mode	Meaning	Module State
BOOT	Steady	The module is rebooting	All predictors, island, inputs and outputs are deenergized
INIT	Steady	The module is performing its initialization	All predictors, island, inputs and outputs are deenergized

Table 44: Module State During Boot-up

Indication	Module State
BOOT	Rebooting
INIT	Initializing
GHWR	Checking Hardware
UCFG	The module is unconfigured and awaiting its configuration from the CPU.
GSTB /ISTB	The GCP and Island are stabilizing
Znnn, Xnnn, and, lnnn	When module is healthy, display alternates EZ Value (Znnn), EX Value (Xnnn), and Island X Value (lnnn) where nnn is a 3-digit numeric value.

Table 45: Software Installation Messages

Indication	Mode	Meaning
BOOT	Steady	The setup program is loaded into the CP, the module is in setup mode, or the module is having a new MEF Downloaded

PHASE SHIFT OVERLAY (PSO) MODULE USER INTERFACE (A80428-03)

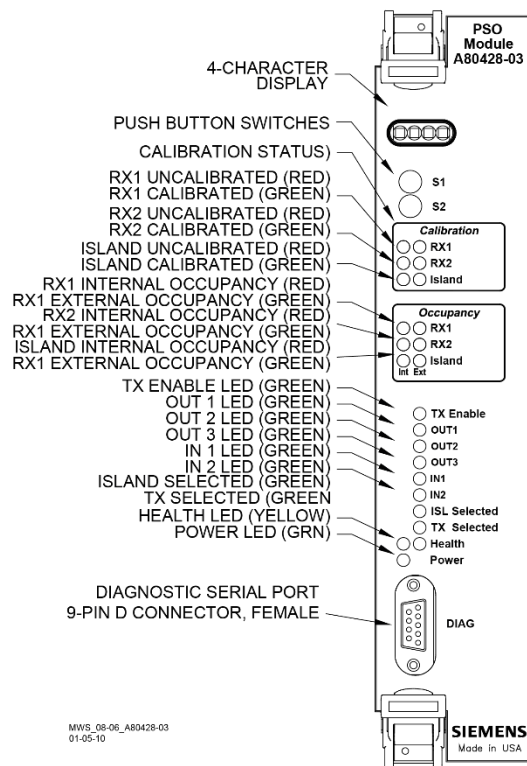

Figure 23: PSO Module, A80428-03

Table 46: PSO Module LED Descriptions

LEDs		DESCRIPTION
NAME	COLOR	
RX1	Red	RX1 not calibrated
RX1	Green	RX1 is calibrated
RX2	Red	RX2 not calibrated
RX2	Green	RX2 is calibrated
Island	Red	Island not calibrated
Island	Green	Island is calibrated
RX1 (Int)	Red	On – RX1 Internal track circuit is unoccupied Off – RX1 Internal track circuit is occupied Flashing – RX1 Internal track circuit is running its pickup delay
RX1 (Ext)	Green	On – RX1 External track circuit is unoccupied Off – RX1 External track circuit is occupied Flashing – RX1 External track circuit is running its pickup delay
RX2 (Int)	Red	On – RX2 Internal track circuit is unoccupied Off – RX2 Internal track circuit is occupied Flashing – RX2 Internal track circuit is running its pickup delay

Table 46: PSO Module LED Descriptions

LEDs		DESCRIPTION
NAME	COLOR	
RX2 (Ext)	Green	On – RX2 External track circuit is unoccupied Off – RX2 External track circuit is occupied Flashing – RX2 External track circuit is running its pickup delay
Island (Int)	Red	On – Island Internal track circuit is unoccupied Off – Island Internal track circuit is occupied Flashing – Island1 Internal track circuit is running its pickup delay
Island (Ext)	Green	On – Island External track circuit is unoccupied Off – Island External track circuit is occupied Flashing – Island External track circuit is running its pickup delay
TX Enable	Green	On – TX is enabled Off – TX is disabled
OUT 1	Red	On – output energized Off – output de-energized or failed
OUT 2	Red	On – output energized Off – output de-energized or failed
OUT 3	Red	On – output energized Off – output de-energized or failed
IN 1	Red	On – input energized Off – input de-energized or failed
IN 2	Red	On – input energized Off – input de-energized or failed
HEALTH	Yellow	Slow (1Hz) – module is healthy and communicating with CPU. Fast (2Hz) – module is healthy but not communicating with CPU. Very Fast (4Hz) – module is unhealthy and communicating with CPU.
POWER	Green	On steadily when power is applied to the module
*PSO	*blinks on and off, PSO steady	Module is healthy No trains are detected on the approach
*CAL	CAL and GCAL or ICAL	GCP Calibration in progress

Table 47: PSO Module Indications (Operational)

Indication	Mode	Meaning	Module State
*CAL	Blinks on and off	Island Calibration in progress	Island is de-energized

Table 48: Boot-up Messages

Indication	Mode	Meaning	Module State
BOOT	Steady	The module is rebooting	All sticks, island, inputs and outputs are deenergized
INIT	Steady	The module is performing its initialization	All sticks, island, inputs and outputs are deenergized

Table 49: Module State During Boot-up

Indication	Module State
BOOT	Rebooting
INIT	Initializing
UCFG	The module is unconfigured and awaiting its configuration from the CPU.
PSO *PSO	Module is healthy

Table 50: Software Installation Messages

Indication	Mode	Meaning
BOOT	Steady	The setup program is loaded into the CP, the module is in setup mode, or the module is having a new MEF Downloaded

DISPLAY MODULE, A80485-1

NOTE

The GCP 4000 uses Siemens Rail's Display Module, A80485-1 rather than Siemens Rail's Display II Module, A80407-03 which has been replaced due to obsolescence.

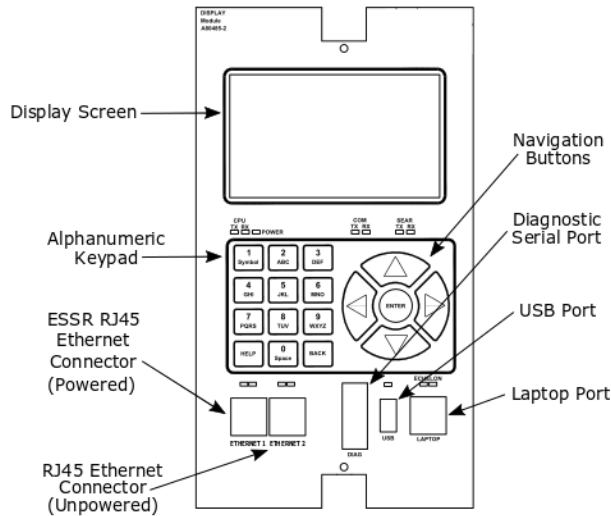

Figure 24: Display Module, A80485-1

**SOLID-STATE CROSSING CONTROLLER (SSCC IIIi)
MODULE USER INTERFACE (A80405)**

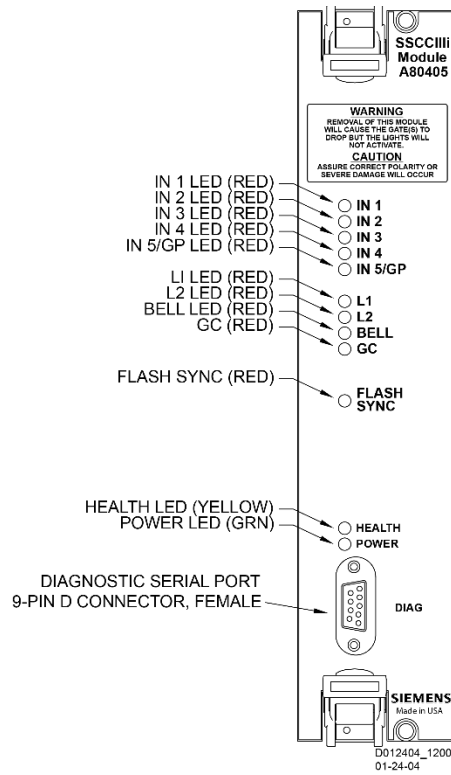

Figure 25: Solid State Crossing Controller IIIi (SSCC IIIi) Module, A80405

Table 51: SSCC IIIi LED Descriptions

LED		Description
Name	Color	
IN 1	Red	On – input 1 energized Off – input 1 de-energized
IN 2	Red	On – input 2 energized Off – input 2 de-energized
IN 3	Red	On – input 3 energized Off – input 3 de-energized
IN 4	Red	On – input 4 energized Off – input 4 de-energized
IN 5/GP	Red	On – input 5 energized Off – input 5 de-energized
L1	Red	On – Lamp Output L1 is on Off – Lamp Output L1 is off
L2	Red	On – Lamp Output L2 is on Off – Lamp Output L2 is off
BELL	Red	On – bell output is on Off – bell output is off
GC	Red	On – gate control (GC) output is energized Off – gate control (GC) output is de-energized

Table 51: SSCC IIIi LED Descriptions

LED		Description
Name	Color	
FLASH SYNC	Red	Flashes when sync pulse is present at FLASH SYNC input/output
HEALTH	Yellow	Slow (1Hz) – module fully operational and communicating with CPU Fast (2Hz) – not communicating with CPU Very Fast (4Hz) – fault detected within the module
POWER	Green	On steadily when power is applied to the SSCC IIIi module

SSCC IIIi GENERAL INFORMATION

The A80405 Solid-State Crossing Controller IIIi (SSCC IIIi), Figure 25, is a plug-in module for the 4000 Grade Crossing Predictor (GCP). All multi-track 4000 GCP cases accommodate two A80405 modules. Each module provides:

- up to 20-amperes of lamp drive
- gate and bell control

A80405 module Interface is through GCP front-panel connectors.

- The A80405 module generally operates from a separate battery than the GCP portion of the system

The SSCC IIIi modules are integrated into the 4000 GCP system. Wiring between the GCP, the SSCC IIIi, and the SEAR IIIi is eliminated.

NOTE

The SSCC IIIi Module is not redundant.

Unit Overview

The A80405 module is programmed, calibrated, and tested from the Display module of the 4000 GCP, is activated by internal logic from the 4000 GCP, monitors gate position inputs from the crossing gate mechanism, and provides activation for the bell, lamps, and gates of a crossing warning system

Module Function Control

The following A80405 module functions may be programmed:

- lamp flash rate
- gate control delay
- low battery threshold indication
- control maintenance call output
- test timer intervals
- crossing and lamp tests
- lamp flashing synchronization between the A80405 modules of multiple 4000 GCPs
- disabling of crossing bells while the gates are rising
- disabling of crossing bells while the gates are down
 - requires gate down inputs to be energized

Crossing Controller Regulation for Lamp Voltage Outputs

- The circuits of the A80405 use pulse width modulation regulation
- The pulsed output frequency is approximately 500 Hz.
- The peak voltage of the pulse is approximately 1 volt below the battery input voltage.
- Depending on the voltage in, the pulse width is automatically varied to give a regulated output.
- The following examples assume the desired output is 10 volts:
- Example 1: 16 volts in, the pulse is 15 volts and on 66% of the cycle.
- Example 2: 13 volts in, the pulse is 12 volts and on 83% of the cycle.

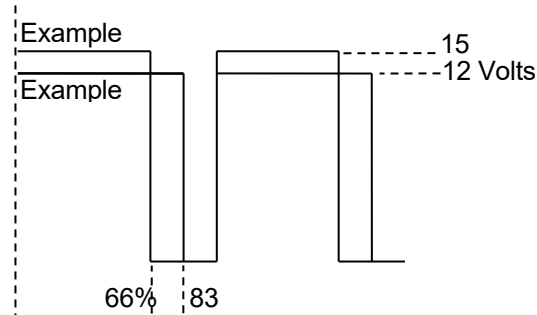

Figure 26: Pulse Width Modulation – Examples

NOTE

The regulated lamp drive is a pulse-width modulated voltage with an AC component and a DC component. A True RMS AC+DC meter is required to accurately read the pulse-modulated lamp voltage (i.e., Agilent model U1252A). Conventional multimeters may be used, however, the voltage reading will vary from the true RMS value. The variance is not a set percentage and is dependent on battery voltage.

A conversion chart cross-referencing several conventional meters is in Using a Conventional Meter on Table 18.

Module Health

The CPU of the A80405 module provides an output that controls the HEALTH LED on the module front panel. Yellow HEALTH LED reflects the health of the module:

- Flashes at 1 Hz rate when module fully operational.
- Flashes at 2 Hz rate when module not communicating with CPU module.
- Flashes at 4 Hz rate when fault is detected within the module.

Battery Surge Protection and Power Wiring

Battery surge protection for the SSCC is shown in Figure 27 below.

Primary surge protection for SSCC modules provided on SSCC battery (see inside dotted line)

Primary surge protection for I/O interconnect provided on lighting surge panels (see Page 143).

Provide power wiring to A80405 SSCC Illi modules:

- via **B** and **N** contacts of the respective crossing controller connectors on 4000 GCP front panel.
- using poly-jacketed #10 AWG wire (recommended) for DC power and return between battery surge protection and the 4000 GCP crossing controller connectors.

Provide power wiring to the lighting surge panels:

- using poly-jacketed #6 AWG wire (recommended) for DC power and return between the A91181-1 lighting surge panel and the crossing gate battery posts.
- using poly-jacketed #10 AWG wire (recommended) for DC power and return between the A91181-1 lighting surge panel and the A91181-2 lighting surge panel.

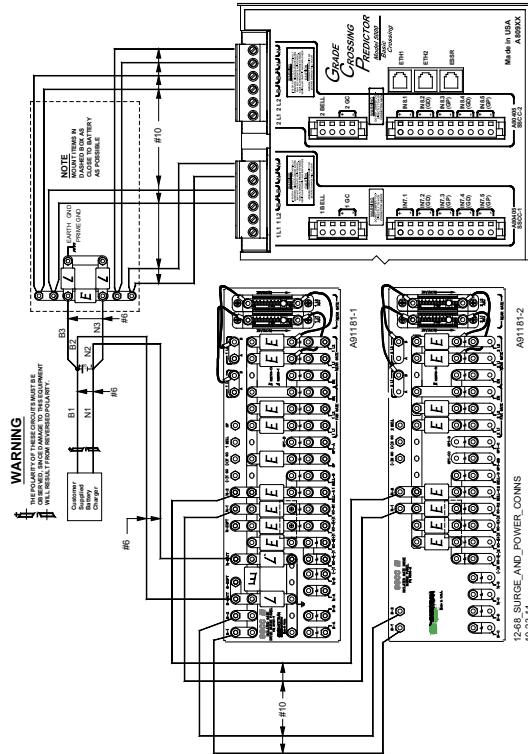

Figure 27: Surge & Power Connections to SSCC Modules & Lighting Surge Panels

Lighting Surge Panels

The A80405 modules use either of two SSCC Illi Lighting Surge Panel configurations to provide external I/O primary surge protection.

A91181-1, -2 isolated gate control, Figure 28A and Figure 28B

The Surge Panel configuration provides surge protection on all external I/O interconnects.

The SSCC Illi Lighting Surge Panels provide:

- arresters and equalizer for surge protection from transients on underground-cable battery voltage
- protection on all other I/O underground cable connections
- insulated links in the underground cable connections

- adjustable resistors in the **NEAR GATE** Lamp 1 (1 L1) and Lamp 2 (1 L2) circuits
- steering diodes for the Crossing Controller Gate Control output to provide isolation between the two crossing gate controls (see Figure 28)

For isolated gate control, a single A91181-1 panel (Figure 28A) is used for 20-ampere operation and both an A91181-1 and an A91181-2 panel (Figure 28B) are generally used for 21 to 40-ampere operation. Refer to Figure 29 for typical isolated gate control wiring.

NOTE

For information on the selection and installation of the 91181-1 SSCC IIII Lighting Surge Panels, refer to Page 143.

A: A91181-1

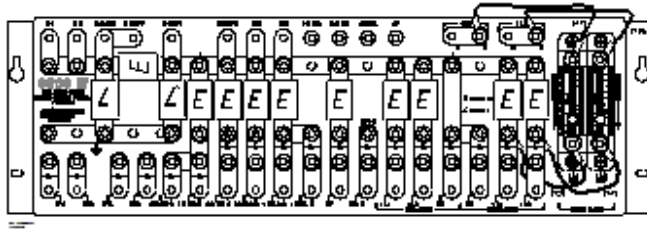

B: A91181-2

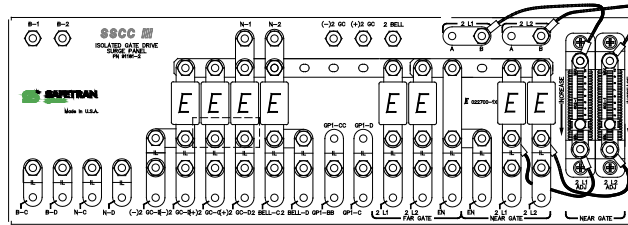

12-68_A91181-2
10-23-14

Figure 28: Isolated Return Lighting Surge Panels, A91181-1 & A91181-2

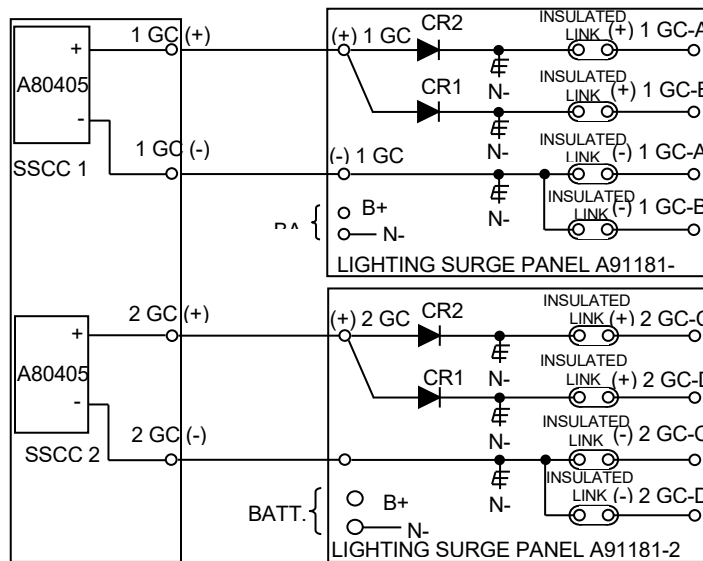

Figure 29: Typical Isolated Gate Control

SSCC IIIi OPERATION

The A80405 module provides drive for up to 20 amps of lamp current.

Failure Operation

The A80405 module continually performs self-diagnostic tests that result in complete on-line testing of module operation.

- If a critical failure is detected, the appropriate signal states are generated to immediately flash the crossing lamps and bring down the gates.

⚠ WARNING

REMOVING INPUT POWER FROM THE A80405 MODULE CAUSES THE GATES TO DROP BUT THE LAMPS ARE NOT ACTIVATED.

IF B OR N ARE FULLY OR PARTIALLY REMOVED, SIGNALS AND/OR GATES MAY NOT OPERATE AS INTENDED. TAKE ALTERNATE MEANS TO WARN VEHICULAR TRAFFIC, PEDESTRIANS AND EMPLOYEES.

Crossing Controller Module Installation

Two non-redundant A80405 Solid-State Crossing Controller IIIi (SSCC IIIi) modules can be installed in the 4000.

Crossing Controller lamp and bell circuit wiring includes:

- Installation of wiring between the 4000 GCP Crossing Controller connectors and the SSCC IIIi Lighting Surge Panels
- Installation of underground wiring between the SSCC IIIi Lighting Surge Panels and the crossing Mast Junction Boxes
- Use of SSCC IIIi Lighting Surge Panel(s)

Where one signal is controlled by each Controller Module, one surge panel (-1) may be used for both modules.

⚠ WARNING

WHEN ONE FLASHING LIGHT SIGNAL IS CONTROLLED BY EACH SSCC MODULE, A SINGLE SURGE PANEL MAY BE USED. JUMPER LINKS FROM A TO B MUST BE REMOVED IN TWO PLACES.

WHEN TWO FLASHING LIGHT SIGNALS ARE CONTROLLED BY A SINGLE SSCC MODULE, A SINGLE SURGE PANEL MAY BE USED. JUMPER LINKS FROM A TO B MUST BE INSTALLED IN TWO PLACES.

Where two signals are controlled by a single Crossing Controller Module, one surge panel (-1) may be used. Where multiple signals are controlled by each Crossing Controller Module, an additional -2 surge panel is required and is wired and jumper links installed but connected to the second SSCC module connector.

Crossing Controller Connectors

The 4000 GCP Crossing Controller connectors accommodate all wiring between the A80405 module(s) and the 91181 SSCC Illi Lighting Surge Panel(s).

Recommended crossing controller connector wire sizes are listed in Table 52.

Use of stranded wire is recommended.

Table 52: Minimum Recommended Crossing Controller Wire Sizes

External Wiring Connector	Pin	Connector Type	Wire Size
SSCC-1	1L1	6-pin screw terminal	10AWG
	1L2	6-pin screw terminal	10AWG
	B	6-pin screw terminal	10AWG
	N	6-pin screw terminal	10AWG
	1BELL	4-pin cage clamp	16AWG
	+1GC	4-pin cage clamp	16AWG
	-1GC	4-pin cage clamp	16AWG
	+1IN7.1	10-pin cage clamp	16AWG
	-1IN7.1	10-pin cage clamp	16AWG
	+IN7.2 (GD)	10-pin cage clamp	16AWG
	-IN7.2 (GD)	10-pin cage clamp	16AWG
	+IN7.3 (GP)	10-pin cage clamp	16AWG
	-IN7.3 (GP)	10-pin cage clamp	16AWG
	+IN7.4 (GD)	10-pin cage clamp	16AWG
	-IN7.4 (GD)	10-pin cage clamp	16AWG
	+IN7.5 (GP)	10-pin cage clamp	16AWG
-IN7.5 (GP)	10-pin cage clamp	16AWG	
SSCC-2	2L1	6-pin screw terminal	10AWG
	2L2	6-pin screw terminal	10AWG
	B	6-pin screw terminal	10AWG
	N	6-pin screw terminal	10AWG
	2BELL	4-pin cage clamp	16AWG
	+2GC	4-pin cage clamp	16AWG
	-2GC	4-pin cage clamp	16AWG
	+IN8.1	10-pin cage clamp	16AWG
	-IN8.1	10-pin cage clamp	16AWG
	+IN8.2 (GD)	10-pin cage clamp	16AWG

Table 52: Minimum Recommended Crossing Controller Wire Sizes

External Wiring Connector	Pin	Connector Type	Wire Size
	-IN8.2 (GD)	10-pin cage clamp	16AWG
	+IN8.3 (GP)	10-pin cage clamp	16AWG
	-IN8.3 (GP)	10-pin cage clamp	16AWG
	+IN8.4 (GD)	10-pin cage clamp	16AWG
	-IN8.4 (GD)	10-pin cage clamp	16AWG
	+IN8.5 (GP)	10-pin cage clamp	16AWG
	-IN8.5 (GP)	10-pin cage clamp	16AWG

⚠ CAUTION

CROSSING WIRING MUST CONFORM TO APPROVED RAILROAD SCHEMATICS.

WHEN INSTALLING B AND N TERMINAL WIRES, OBSERVE CORRECT POLARITY OR SEVERE DAMAGE TO THE A80405 MODULE WILL OCCUR. USE THE CORRECT SCREWDRIVER BLADE SIZE TO AVOID CONNECTOR DAMAGE. FOR WIRE PREPARATION AND INSERTION INSTRUCTIONS, REFER TO WIRE PREPARATION & INSERTION INSTRUCTIONS FOR KEYED INTERFACE CONNECTORS.

Lamp and Bell Wiring to the Lighting Surge Panel

Recommended wire size for L1 and L2 between the Lighting Surge Panel and the 4000 SSCC power connector is number 10 AWG.

- Recommended wire size between the Lighting Surge Panel and the Mast Junction Box is number 6 AWG.
- The Lighting Surge Panel should be mounted as close as practical to the 4000 GCP.

⚠ WARNING

USE CAUTION WHEN SETTING BATTERY VOLTAGE, ESPECIALLY WHEN USING TEMPERATURE COMPENSATED BATTERY CHARGERS:

EXCEEDING 16.5 VDC ON CROSSING CONTROLLER POWER TERMINALS MAY RESULT IN INTERMITTENT FALSE ACTIVATIONS.

EXCEEDING 18 VDC WILL RESULT IN CONTROLLER DAMAGE.

OBSERVE CORRECT POLARITY WHEN CONNECTING BATTERY POWER TO THE B AND N CONTACTS ON THE

**CROSSING CONTROLLER
CONNECTOR(S). INCORRECT
POLARITY WILL RESULT IN SEVERE
DAMAGE TO THE A80405 MODULE(S).**

Crossing Controller DC Power Connections

The A80405 modules receive power via the Lighting Surge panel and the **CROSSING CONTROLLER** connectors as shown in Figure 27:

Surge panel provides primary battery surge protection.

- Secondary surge protection provided by each A80405 module

Make power connections to each A80405 module via the **B** and **N** contacts of the respective **CROSSING CONTROLLER** connectors:

Poly-jacketed 10AWG wire is recommended for DC power and return between the lighting surge panel and the 4000 GCP.

Poly-jacketed 6AWG wire is recommended for DC power and return between the lighting surge panel and the crossing battery.

Connecting Power at Initial Cutover or After Changes to Warning Device Wiring

Once the system has booted up, the SSCC IIIi module has internal short circuit protection for lamp, bell and gate control outputs. Therefore, at the initial cutover it is important to boot up the system prior to connecting external loads.

After external wiring is complete, the connectors must be applied as instructed in the following CAUTION before applying power to the 4000 GCP SSCC IIIi module(s).

⚠ WARNING

DURING THE SSCC IIIi BOOT-UP PROCESS AND AFTER ALL WIRING IS CONNECTED:

THE CROSSING GATES WILL BE DOWN WITH CROSSING LAMPS FLASHING AND BELLS RINGING; A80405 MODULE(S) WILL NOT BE RESPONSIVE TO CROSSING CONTROL INPUT FROM THE 4000 GCP. TAKE ADEQUATE PRECAUTIONS TO WARN ANY PEDESTRIANS, PERSONNEL, TRAINS, AND VEHICLES IN THE AREA UNTIL PROPER SYSTEM OPERATION IS VERIFIED.

CAUTION

THE WIRING AND CONNECTORS MUST BE APPLIED IN THE FOLLOWING SEQUENCE TO AVOID DAMAGE:

OPEN THE LAMP, GATE GC CONTROL, GP INPUTS, GD INPUTS AND BELL CIRCUITS AT THE SURGE PANEL(S).

VERIFY POLARITY ON POWER CONNECTOR(S).

CONNECT THE SCREW-LOCK POWER CONNECTOR FOR EACH SSCC IIIi MODULE AND LOCK BY TIGHTENING SCREWS.

WAIT APPROXIMATELY 40 SECONDS FOR SSCC IIIi MODULE(S) TO BOOT UP.

CONNECT THE GC/BELL AND GP/GD CAGE-CLAMP CONNECTORS FOR THE APPROPRIATE SSCC IIIi.

CLOSE THE LAMP, GATE CONTROL, GP/GD INPUTS AND BELL CIRCUITS ON THE SURGE PANEL(S).

RELAY INPUT OUTPUT (RIO) MODULE USER INTERFACE (A80413)

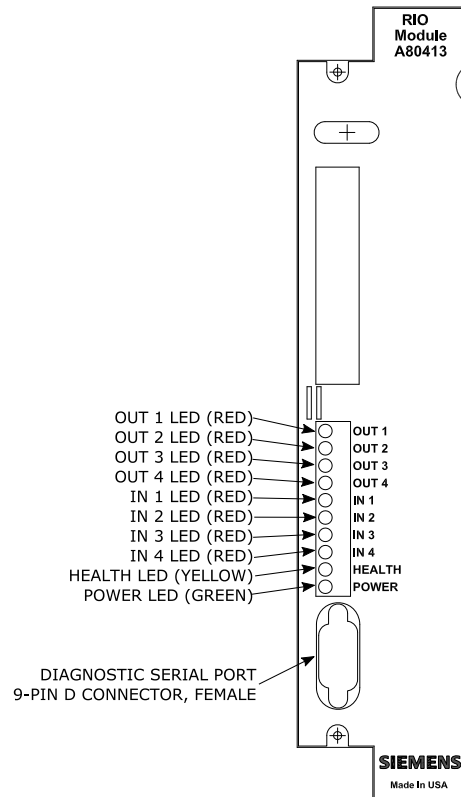

Figure 30: Relay Input Output Module (RIO), A80413

Table 53: RIO Module LED Descriptions

LED		Description
Name	Color	
OUT 1	Red	On – vital Output 1 energized Off – vital Output 1 de-energized
OUT 2	Red	On – vital Output 2 energized Off – Vital Output 2 de-energized
OUT 3	Red	On – vital Output 3 energized Off – vital Output 3 de-energized
OUT 4	Red	On – vital Output 4 energized Off – vital Output 4 de-energized
IN 1	Red	On – vital Input 1 energized Off – vital Input 1 de-energized
IN 2	Red	On – vital Input 2 energized Off – vital Input 2 de-energized
IN 3	Red	On – vital Input 3 energized Off – vital Input 3 de-energized
IN 4	Red	On – vital Input 4 energized Off – vital Input 4 de-energized
HEALTH	Yellow	Slow (1Hz) – module fully operational communicating with CPU Fast (2Hz) – module is not communicating with CPU Very Fast (4Hz) – fault detected within the module
POWER	Green	On steadily when power is applied to the RIO module

TRANSFER MODULES (A80406, A80468)

Two transfer modules are available depending on the 4000 GCP system chassis installed:

- A80406 Transfer Module - used in the Dual Four Track Chassis, A80400, and Dual Six Track Chassis, A80460.
- A80468 Transfer Module - used on the Dual Two Track Chassis, A80465.

The Timer Controls, LEDs, and Timer Display on each module function the same. Refer to Figure 31 and Figure 32 for control, LED and display locations.



AT CROSSINGS USING MEFS XNG02_00.MEF AND EARLIER, GATES WILL BEGIN TO LOWER IMMEDIATELY (WITHOUT GATE DELAY TIME) WHEN THE TRANSFER SWITCH IS USED TO SWAP BETWEEN HEALTHY UNITS. USE CAUTION WHEN TRANSFERRING CONTROL TO AVOID GATES HITTING VEHICLES OR PEDESTRIANS.

NOTE

Under normal conditions in the AUTO Transfer mode, gate delay time will run when the gates initially operate. If the trouble continues, the gates will already be lowered when the Transfer Module later swaps units.

Transfer Module User Interfaces

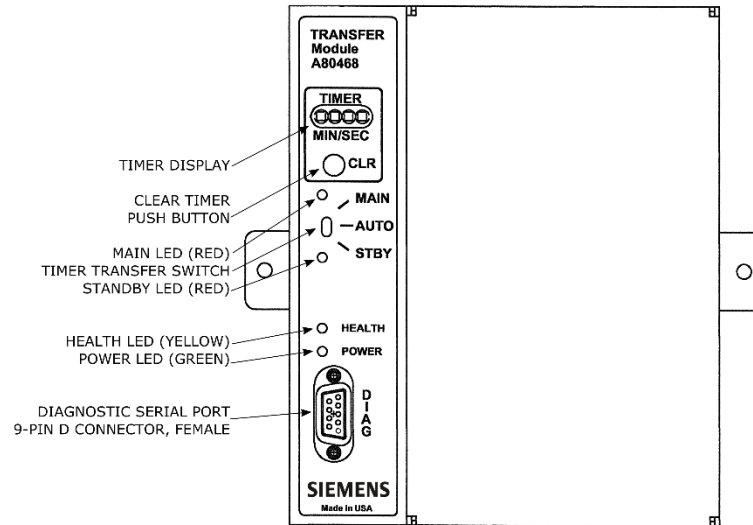

Figure 31: Transfer Module A80468, Front Panel

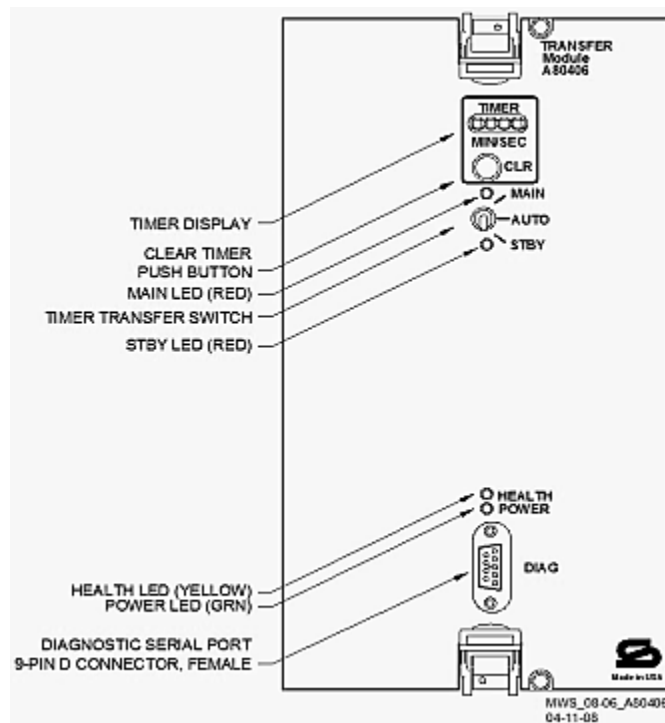

Figure 32: Transfer Module, A80406, Front Panel

Table 54: Transfer Module LED Descriptions

LED		Description
Name	Color	
MAIN	Red	<p>On – Main modules enabled while Transfer Timer Switch is set to AUTO or Transfer Timer Switch is set to MAIN</p> <p>Off – Main side is currently not powered</p>
STBY	Red	<p>On – Standby modules enabled while Transfer Timer Switch is set to AUTO or Transfer Timer Switch is set to STBY</p> <p>Off – Standby side is currently not powered</p>
HEALTH	Yellow	Slow (1Hz) – Module is functioning normally
POWER	Green	On steadily when power is applied to the Transfer module

When transfer delay is set using DIP switch S3, the Transfer Module 4-character display shows the:

- set transfer delay time in minutes and seconds
- transfer timer delay count down in 1 sec. increments
- selected module set (MAIN or STBY)

Table 55: Transfer Module Timer Display Indications

Indication	Mode	Meaning	Module State
MAIN	Steady	Timer Transfer switch is set to Main	Main side is powered
STBY	Steady	Timer Transfer switch is set to Standby	Standby side is powered
MMSS e.g. 0240 (2 mins 40 secs)	Steady	If the number is not changing, the module is set to AUTO. This represents the programmed transfer time.	Main or Standby side is powered
MMSS e.g. 0200 (2 mins 00 secs)	Decreasing	If the number is decreasing, the module is set to AUTO. The currently selected side is unhealthy and this number represents the time taken until a transfer occurs.	Main or Standby side is powered
MMSS alternating with SWCH	Steady	SWCH shows the module has transferred since the CLR button was pressed	Main or Standby side is powered

Table 56: Transfer Module Timer Controls

Item	Function
CLR (Clear Timer) push button	Clears transfer delay time from counter. When pressed during timer countdown: Sets the timer to the selected Transfer Delay Interval, and Initiates immediate transfer of GCP operation to opposite modules. Switches MAIN to STANDBY or Switches STANDBY to MAIN
Timer Transfer Switch	Three-position toggle switch: MAIN position enables only main module operation and will not automatically transfer. AUTO position enables automatic switch over to opposite set of modules: transfers from main modules to standby modules when main module failure is detected, or transfers from standby modules to main modules when standby module failure is detected. STBY position enables only standby module operation and will not automatically transfer. To switch from one set of modules (MAIN or STBY) to the other set of modules <u>when the transfer time is not counting down</u> , move the switch from AUTO to the desired position (MAIN or STBY). Then turn switch to AUTO .

Transfer Delay Interval Selection

The transfer delay interval for the transfer modules is set by the positions of the switch segments on switch assembly 3, (S3). The switch positions required to set the desired number of minutes are shown in Table 57; a similar table is located on each module. The delay range is 0 to 31 minutes, in 1-minute increments. The factory setting is 3 minutes.

Table 57: Transfer Delay Interval Settings

Minutes	S3-0	S3-1	S3-2	S3-3	S3-4
0	0	0	0	0	0
1	1	0	0	0	0
2	0	1	0	0	0
3	1	1	0	0	0
4	0	0	1	0	0
5	1	0	1	0	0
6	0	1	1	0	0
7	1	1	1	0	0
8	0	0	0	1	0
9	1	0	0	1	0
10	0	1	0	1	0
11	1	1	0	1	0
12	0	0	1	1	0
13	1	0	1	1	0
14	0	1	1	1	0
15	1	1	1	1	0
16	0	0	0	0	1
17	1	0	0	0	1
18	0	1	0	0	1
19	1	1	0	0	1
20	0	0	1	0	1
21	1	0	1	0	1
22	0	1	1	0	1
23	1	1	1	0	1
24	0	0	0	1	1
25	1	0	0	1	1
26	0	1	0	1	1
27	1	1	0	1	1
28	0	0	1	1	1
29	1	0	1	1	1
30	0	1	1	1	1
31	1	1	1	1	1

0 is OPEN (UP, away from board).
 1 is CLOSED (DOWN, towards board)
 Bold is default setting

NOTE

When viewing switch S3 with the transfer module in the normal operating position, the orientation of S3 on the A80468 module is inverted compared to the orientation of S3 on the A80406 module. This changes the location of switch position S3-0. Refer to Figure -33 and Figure 34 for switch position locations.

After changing switches on S3, verify timer setting by switching the timer transfer switch to AUTO. The transfer time (MM:SS) will be displayed in minutes and seconds on the 4-character display.

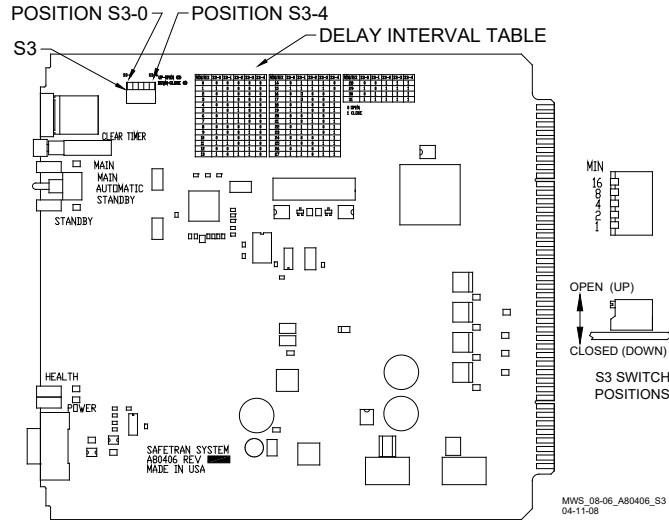

Figure 33: Transfer Module, A80406, S3 Switch Positions

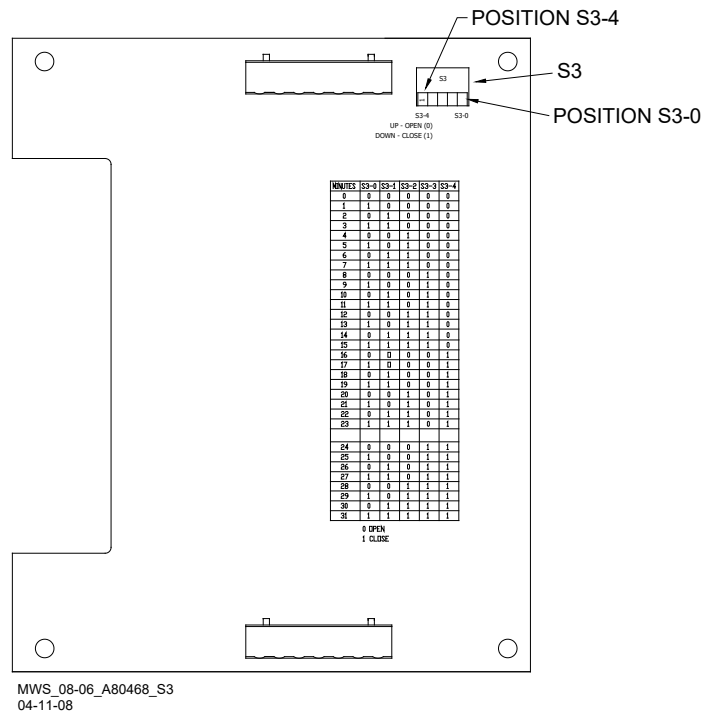

Figure 34: Transfer Module, A80468, S3 Switch Positions

Operation Without Transfer Module A80406

To disable the A80406 Transfer Module, remove the module from the chassis and move the jumper from the storage position, STG, to the MAIN or standby (STBY) position (see Figure 35).

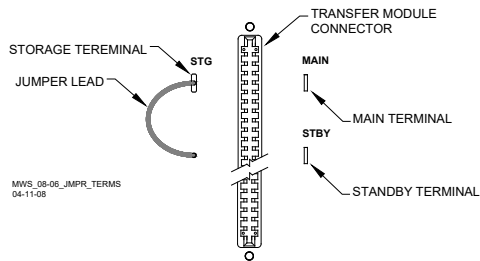

Figure 35: Transfer Module (A80406) Jumper Positions

Operation Without Transfer Module A80468

To disable the A80468 Transfer Module, remove the module from the chassis and move the jumper from the storage position, STG, to the MAIN or standby (STBY) position (see Figure 36 for all cases except A80475 or Figure 37 for the A80475).

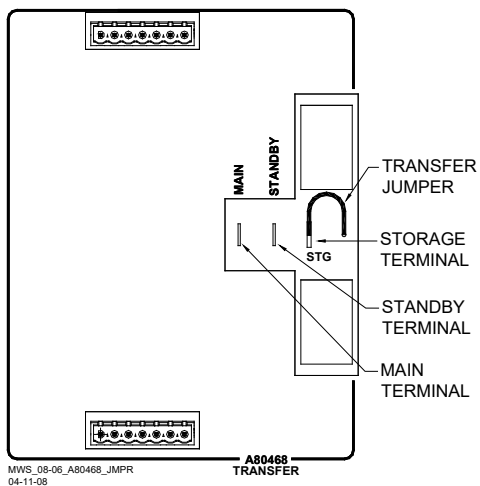

Figure 36: Transfer Module (A80468) Jumper Positions (All cases except A80475)

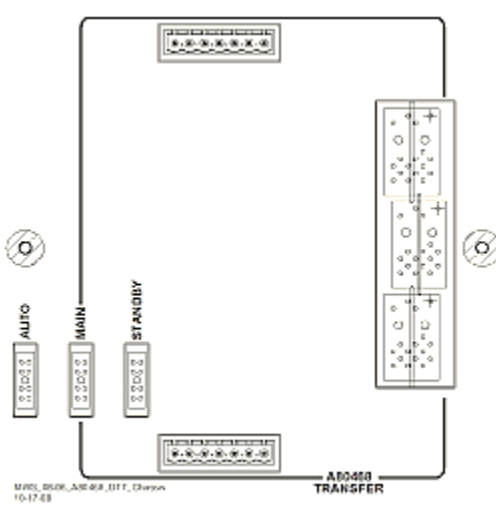

Figure 37: Transfer Module (A80468) Jumper Positions (Case A80475 Only)

APPENDIX B – OPTIONAL REMOTE CALIBRATION AND REMOTE CROSSING LAMP VOLTAGE ADJUSTMENT PROCEDURES

Optional remote GCP calibration and Crossing lamp voltage adjustment may be used as needed. The remote calibration and adjustment procedures are the same as the other procedures, except that the person doing the adjustment or calibration communicates directly with the GCP via VHF radio. The GCP sends voice options and the person performing the operation replies via a DTMF keypad on a VHF radio. The VHF Communicator is connected as depicted in Figure 38.

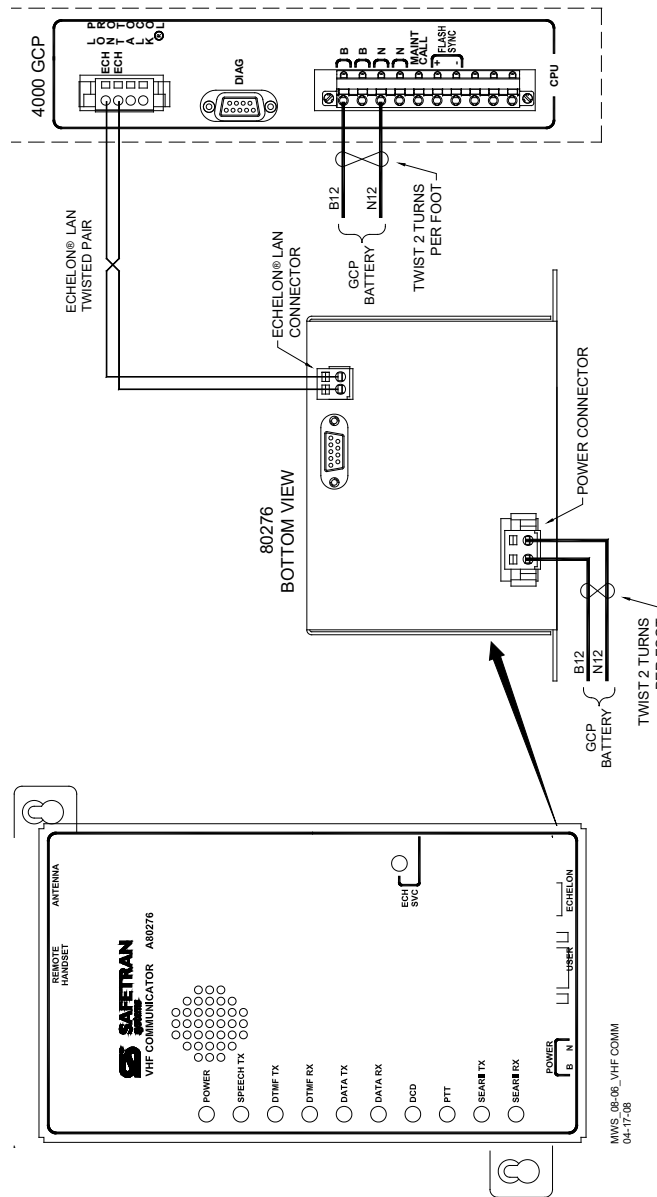

Figure 38: Connecting the VHF Communicator, A80276

REMOTE CALIBRATION EQUIPMENT REQUIREMENTS

To perform remote calibration and/or lamp adjustment the following are required:

1. Siemens Rail VHF Communicator (A80276)
programmed and connected to the GCP Echelon LAN.
 - VHF Communicator is a VHF Radio interface to the 4000 GCP that sends setup and calibration options to remote radio.
 - VHF Communicator set to a railroad VHF frequency.
2. Hand-held VHF radio with DTMF keypad.
 - Person doing remote calibration responds to options and sends commands to GCP.
 - Set to same frequency as VHF communicator.
3. Hardwire test shunt for calibration and appropriate voltmeter for lamp adjustments.

SETUP SYSTEM FOR REMOTE CALIBRATION

NOTE

The GCP sends and receives commands via the VHF Communicator which includes a half-duplex radio. The radio cannot receive a reply until it is finished transmitting. DO NOT send back responses until the message is completed.

To enter a password or to select a value on the handheld VHF radio, press and hold the transmit button/key, then enter the numeric key values required.

A password must be preceded by an asterisk and a number symbol (*#) to be accepted as valid.

When an invalid password is received, the menu system is disabled for 30 seconds. When the menu system is reactivated (after 30 seconds), the correct password must be entered to continue.

After a valid password is entered, the system will respond with the DTMF tones for “##.”

Entering “##” at any time during remote operation returns the function to the initial Start position.

Prior to attempting to begin remote calibration, the DOT Crossing Number must be entered. To set the DOT Number, scroll to **PROGRAM VIEW>1) SITE Setup>1) Site Configuration**. The **Site Configuration** screen opens. Enter the DOT Number value from the information found in the approved drawings. During remote calibration, the DOT number is used to identify that the proper location is being calibrated.

REMOTE CALIBRATION OPERATIONS

This section includes flow charts for the commands and choices used in setup and calibration:

- Remote calibration setup
- Enable remote calibration and prime track
- Remote GCP calibration
- Remote approach and linearization calibration
- Remote island calibration
- Remote lamp voltage adjustment
- Remote calibration termination

Remote Calibration Setup

Table 58: Remote Calibration Setup

Step 1	Scroll to SYSTEM VIEW , and select the track to be calibrated, e.g., 1 – 6. The Track Options screen opens.
Step 2	From the Track Options screen, select 5) REMOTE SETUP . The Remote Setup dialog box displays.
Step 3	On the Remote Setup parameter where the word GET appears, select the Enter button. A Push button message appears in the message box at the bottom of the window.
Step 4	Press the SEL pushbutton on the front panel of the CPU module. The Remote Setup dialog box changes. A four-digit password appears in the Remote Password value field.
Step 5	Record the four-digit password.
Step 6	If calibrating track(s), scroll to Remote Cal Track “N” and select Enter . Scroll to True and select Enter . Set all tracks to be calibrated to True .
Step 7	If calibrating the SSCCs, scroll to Remote Cal SSCC and select Enter . Scroll to True and select Enter . Set all tracks to be calibrated to True .
Step 8	If the default 60-minute timeout is not long enough, scroll to Remote Setup Timeout (Min) and select Enter .
Step 9	Using the keypad numbers, enter the required Setup Timeout value (range 1 – 120 minutes) into the Remote Setup Timeout (min) screen.
Step 11	To perform an Island Calibration, go to the Island Calibration screen and record the shunt placement distance for shunting sensitivity.

WARNING

AFTER PERFORMING REMOTE GCP CALIBRATION USING THE VHF COMMUNICATOR, RETURN TO THE 4000 GCP AND VERIFY THAT EACH CALIBRATION IS PROPERLY IMPLEMENTED. REVIEW THE MAINTENANCE LOG OR THE CPU STATUS LOG AS PART OF THE VERIFICATION PROCESS.

Enable Remote Calibration For Track

NOTE

The figures beginning at Figure 39 and ending at Figure 45 provide a detailed flow chart of the “Remote User Interface Menu”.

Table 59: Remote Calibration

Step 1	Press and Hold the Transmit button of the hand-held VHF radio.
Step 2	Enter *# followed by the password recorded in step 5 of Table 58.
Step 3	Release the Transmit button of the hand-held VHF radio. An assigned Department Of Transportation (DOT) number (XXX) is verbally announced. The Root menu options are announced: “For location press 1” “For GCP press 2” “For SSCC press 3” “For Help press 4”
Step 4	Press and Hold the Transmit button then Press 2. <ul style="list-style-type: none"> GCP is selected.
Step 5	Release the Transmit button. <ul style="list-style-type: none"> An “Enter track number” message is announced
Step 6	Press and Hold the Transmit button. <ul style="list-style-type: none"> Enter the track number (N) to be calibrated (N = 1 to 6).
Step 7	Release the Transmit button. The Track Menu options are announced: <ul style="list-style-type: none"> “For GCP calibration press 1” “For approach calibration press 2” “For linearization press 3” “For island calibration press 4” “To monitor EZ EX press 5” “To monitor island, press 6”

Remote GCP Calibration

Table 60: Remote GCP Calibration

Step 1	To perform the GCP Calibration: <ul style="list-style-type: none"> Press and hold the Transmit button/key then press 1. GCP calibration is selected.
Step 2	Release the Transmit button. The Calibration Menu options are announced: <ul style="list-style-type: none"> “To start track N GCP calibration press 1” “To monitor EZ EX press 2”
Step 3	Press and Hold the Transmit button then Press 1.
Step 4	Release the Transmit button. <ul style="list-style-type: none"> “Enter password for DOT XXX” is announced.

Table 60: Remote GCP Calibration

Step 5	Press and Hold the Transmit button, press *# , then enter the password recorded in step 5 of Table 58.
Step 6	<p>Release the Transmit button. The following information messages are sequentially announced:</p> <ul style="list-style-type: none"> • “Initiating track N GCP calibration” • “Track N GCP calibration in progress” <p>If GCP calibration passes:</p> <ul style="list-style-type: none"> • The information messages are concluded with: <ul style="list-style-type: none"> • “Track N GCP calibration passed” • “EZ is ____” • “EX is ____” • The Track Menu options in step 7 of Table 59 are repeated. <p>If GCP calibration fails:</p> <ul style="list-style-type: none"> • The information messages conclude with: <ul style="list-style-type: none"> • “Track N GCP calibration failed” • The calibration menu of step 2 is repeated. • Refer to Section 7 for troubleshooting procedures. • When the cause of the failure is corrected, repeat this procedure starting at step 3. <p>If the Remote Setup Timeout selected in Table 58 step 6 expires, start again from Table 58</p>
Step 7	Begin remote approach calibration

Remote Approach And Linearization Calibration**Table 61: Remote Approach and Linearization Calibration**

Step 1	<p>Temporarily place a hardwire shunt across the termination shunt.</p> <ul style="list-style-type: none"> • For bidirectional installations, use the termination shunt farthest from the crossing
Step 2	<p>Press and Hold the Transmit button then Press 2.</p> <ul style="list-style-type: none"> • Approach calibration is selected.
Step 3	<p>Release the Transmit button.</p> <ul style="list-style-type: none"> • The Calibration Menu options are announced: <ul style="list-style-type: none"> • “To start track N approach calibration, press 1” • “To monitor EZ EX press 2”
Step 4	Press and Hold the Transmit button/key, then Press 1 .
Step 5	<p>Release the Transmit button.</p> <ul style="list-style-type: none"> • “Enter password for DOT ____” is announced.
Step 6	Press and hold the Transmit button/key, press *# , then enter the password recorded in step 5 of Table 58.

Table 61: Remote Approach and Linearization Calibration

Step 7	<p>Release the Transmit button. The following information messages are sequentially announced:</p> <ul style="list-style-type: none"> • “Initiating track N approach calibration” • “Track N approach calibration in progress” <p>If approach calibration passes, the information messages conclude with:</p> <ul style="list-style-type: none"> • “Track N approach calibration passed” • “Computed approach distance ____ ft” • Record this distance as the first approach distance. <ul style="list-style-type: none"> • The Track Menu options in step 7 Table 59 are repeated. <p>If approach calibration fails the information messages conclude with:</p> <ul style="list-style-type: none"> • “Track N approach calibration failed” • The calibration menu in step 3 is repeated. • Refer to Section 7 for troubleshooting procedures. • When the failure is corrected, repeat the procedure starting at step 3. <p>If the Remote Setup Timeout selected in Table 58 step 6 expires, start again from Table 58</p>
Step 8	<p>Accurately (within 1%) locate the midpoint of the longest approach and move the hardwire shunt to that point on the rails.</p>
Step 9	<p>Press and Hold the Transmit button and then Press 3.</p> <ul style="list-style-type: none"> • Linearization is selected.
Step 10	<p>Release the Transmit button. The Calibration Menu options are announced: “To start track N linearization press 1”</p> <ul style="list-style-type: none"> • “To monitor EZ EX press 2”
Step 11	<p>Press and hold the Transmit button then Press 1.</p>
Step 12	<p>Release the Transmit button. An “Enter password for DOT ____” directive is announced</p>
Step 13	<p>Press and hold the Transmit button/key, press *#, and then enter the password recorded in step 5 of Table 58.</p>

Table 61: Remote Approach and Linearization Calibration

Step 14	<p>Release the Transmit button. The following information messages are sequentially announced:</p> <ul style="list-style-type: none"> • “Initiating track N linearization” • “Track N linearization in progress” <p>If linearization passes, the information messages conclude with:</p> <ul style="list-style-type: none"> • “Track N linearization passed” • “Linearization number _____” • Record this number as the first approach value. <ul style="list-style-type: none"> • The Track Menu options, step 7, Table 59, are repeated. <p>If approach linearization fails the information messages are concluded with:</p> <ul style="list-style-type: none"> • “Track N linearization failed” • Release the Transmit button. • The calibration menu from step 10 is repeated. • Refer to Section 7 for troubleshooting procedures. • When the failure is corrected, repeat the procedure from step 10.
Step 15	Remove the hardwire shunt from the track.
Step 16	<p>If the approach is unidirectional or simulated bidirectional, go to step 38. If the track is bidirectional go to step 17.</p>
Step 17	Temporarily place a hardwire shunt across the termination shunt of the other approach.
Step 18	<p>Press and Hold the Transmit button then Press 2.</p> <ul style="list-style-type: none"> • Approach calibration is selected.
Step 19	<p>Release the Transmit button, the Calibration Menu options are announced:</p> <ul style="list-style-type: none"> • “To start track N approach calibration press 1” • “To monitor EZ EX press 2”
Step 20	Press and hold the Transmit button/key, then press 1.
Step 21	<p>Release the Transmit button.</p> <ul style="list-style-type: none"> • “Enter password for DOT _____” is announced
Step 22	Press and hold the Transmit button/key, press *#, then enter the password recorded in step 5 of Table 58.

Table 61: Remote Approach and Linearization Calibration

Step 23	<p>Release the Transmit button. The following information messages are sequentially announced:</p> <ul style="list-style-type: none"> • “Initiating track N approach calibration” • “Track N approach calibration in progress” <p>If approach calibration passes, the information messages conclude with:</p> <ul style="list-style-type: none"> • “Track N approach calibration passed” • “Computed approach distance ____ ft” • Record this distance as the second approach distance value. <ul style="list-style-type: none"> • The Track Menu options in step 7 of Table 59 are repeated. <p>If approach calibration fails, the information messages conclude with:</p> <ul style="list-style-type: none"> • “Track N approach calibration failed” • The calibration menu in step 3 is repeated. • Refer to Section 7 for troubleshooting procedures. • When the failure is corrected, repeat the procedure starting at step 3. <p>If the Remote Setup Timeout selected in Table 58 step 6 expires, start again from Table 58.</p>
Step 24	<p>Accurately (within 1%) locate the midpoint of this approach and move the hardwire shunt to that point on the rails.</p>
Step 25	<p>Press and hold the Transmit button/key and then Press 4.</p> <ul style="list-style-type: none"> • Linearization is selected.
Step 26	<p>Release the Transmit button/key. The Calibration Menu options are announced:</p> <ul style="list-style-type: none"> • “To start track N linearization press 1” • “To monitor EZ EX press 2”
Step 27	<p>Press and hold the Transmit button/key, then Press 1.</p>
Step 28	<p>Release the Transmit button.</p> <ul style="list-style-type: none"> • An “Enter password for DOT ____” directive is announced
Step 29	<p>Press and hold the Transmit button/key, press *#, and then enter the password recorded in step 5 of Table 58.</p>

Table 61: Remote Approach and Linearization Calibration

Step 30	<p>Release the Transmit button. The following information messages are sequentially announced:</p> <ul style="list-style-type: none"> • “Initiating track N linearization” • “Track N linearization in progress” <p>If linearization passes, the information messages conclude with:</p> <ul style="list-style-type: none"> • “Track N linearization passed” • “Linearization number _____” • Record this number as the second approach linearity value. <ul style="list-style-type: none"> • The Track Menu options, step 7, Table 59, are repeated. <p>If approach linearization fails, the information messages are concluded with:</p> <ul style="list-style-type: none"> • “Track N linearization failed” • Release the Transmit button. • The calibration menu from step 10 is repeated. • Refer to Section 7 for troubleshooting procedures. • When the failure is corrected, repeat the procedure from step 10.
Step 31	<p>Remove the hardwire shunt from the track.</p>
Step 32	<p>If the Lin Steps value for the second approach is greater than or the same as the value recorded for the first approach in step 14, record the Lin Steps value, then go to step 38.</p> <p>If the Lin Steps value for the second approach is less than the value recorded in step 14, return to the bungalow and select the EDIT button of the track Linearization calibration menu.</p> <ul style="list-style-type: none"> • The Linearization Steps dialog box displays.
Step 33	<p>Enter the Lin Steps value recorded for the first approach in step 14 into the New Value field using the keypad numbers and select UPDATE.</p>
Step 34	<p>Select the GCP APP button.</p> <ul style="list-style-type: none"> • The GCP Approach Window appears.
Step 35	<p>Select the EDIT button.</p> <ul style="list-style-type: none"> • The Computed Approach Distance dialog box appears.
Step 36	<p>Enter the computed approach distance (Comp Dist) value recorded for the first approach in step 5 into the New Value field using the keypad numbers and select UPDATE.</p> <ul style="list-style-type: none"> • The Calibration Select Window appears.
Step 37	<p>Verify that the computed approach distance (Comp Dist) and the linearization steps (Lin Steps) values recorded for the first approach in steps 14 and 30 are the same as those displayed on the Calibration Select window</p>

Table 61: Remote Approach and Linearization Calibration

Step 38	Enter the distance and linearity values recorded for the first and second (if applicable) approach(es) on the CALIBRATION VALUES history on page 21 of the Application History card.
Step 39	<p>This completes Approach and Linearization calibration.</p> <p>To record the reason for the Calibration and store it in the Maintenance log, select the ADD LOG ENTRY button.</p> <ul style="list-style-type: none"> • Type any notes about the calibration and select OK to save the entry.

Remote Island Calibration

Table 62: Remote Island Calibration

Step 1	<p>Temporarily install a hardwire shunt beyond the island receiver rail connections.</p> <ul style="list-style-type: none"> • Place the shunt at the distance recorded in Table 58, step 11.
Step 2	<p>Press and hold the Transmit button/key then press 6.</p> <ul style="list-style-type: none"> • Island calibration is selected.
Step 3	<p>Release the Transmit button.</p> <p>The Calibration Menu options are announced:</p> <ul style="list-style-type: none"> • “To start track N island calibration press 1” • “To monitor island signal level press 2”
Step 4	<p>Press and hold the Transmit button/key, then press 1.</p>
Step 5	<p>Release the Transmit button/key.</p> <ul style="list-style-type: none"> • An “Enter password for DOT ____” message is announced
Step 6	<p>Press and hold the Transmit button/key, then enter the password recorded in step 5 of Table 58.</p>

Table 62: Remote Island Calibration

Step 7	<p>Release the Transmit button, the following information messages are sequentially announced:</p> <ul style="list-style-type: none"> • “Initiating track N island calibration” • “Track N island calibration in progress” <p>If island calibration passes, the information messages conclude with:</p> <ul style="list-style-type: none"> • “Track N island calibration passed” • “Island signal level n” (where n is around 100). • The Track Menu options in step 7 Table 59 are repeated. <p>If island calibration fails, the information messages conclude with:</p> <ul style="list-style-type: none"> • “Track N island calibration failed” • Release the Transmit button. • The calibration menu from step 3 is repeated. • Refer to the Maintenance and Troubleshooting section for troubleshooting procedures. • When the failure is corrected, repeat the procedure starting at step 2.
Step 8	Remove the hardwire shunt.

Remote Lamp Voltage Adjustment**NOTE**

Before performing the remote lamp voltage adjustment procedure, the crossing controllers must be inactive, i.e. gates up, lamps off, and bell off. If a train approaches during lamp adjustment, the crossing controllers will activate and the lamps will flash.

Table 63: Remote Lamp Voltage Adjustments

Step 1	<p>Press and Hold the Transmit button. Press 3.</p> <ul style="list-style-type: none"> • The remote SSCC menu is selected.
Step 2	<p>Release the Transmit button. The SSCC Menu options are announced:</p> <ul style="list-style-type: none"> • “SSCC 1 press 1” • “SSCC 2 press 2” • “Crossing press 3”
Step 3	<p>Press and hold the Transmit button/key, then Press 1.</p> <ul style="list-style-type: none"> • The SSCC Lamp 1 Menu is selected.
Step 4	<p>Release the Transmit button. The SSCC 1 Lamp Menu options are announced:</p> <ul style="list-style-type: none"> • “Lamp 1 press 1” • “Lamp 2 press 2” • “Lamp 1 voltage press 3” • “Lamp 2 voltage press 4”

Table 63: Remote Lamp Voltage Adjustments

Step 5	Press and hold the Transmit button/key, then Press 3 .
Step 6	Release the Transmit button. <ul style="list-style-type: none"> • “SSCC 1 lamp 1 voltage ___ volts” is announced
Step 7	Press and hold the Transmit button/key, then Press * . <ul style="list-style-type: none"> • The SSCC 1 Lamp 1 Voltage Menu is selected.
Step 8	Release the Transmit button. “SSCC 1 Lamp 1 Voltage” is announced, followed by: <ul style="list-style-type: none"> • “up 1 volt press 1” • “up one-half volt press 2” • “up one-tenth volt press 3” • “down 1 volt press 4” • “down one-half volt press 5” • “down one-tenth volt press 6” • SSCC 1 lamp 1 output is on and steady.
Step 9	Press and hold the Transmit button/key, then press the number required to appropriately increment the voltage level at lamp 1.
Step 10	Release the Transmit button. <ul style="list-style-type: none"> • “SSCC 1 lamp 1 voltage ___ volts” is announced.
Step 11	Repeat step 9 and 10 until the specified voltage reading is obtained at lamp 1. <ul style="list-style-type: none"> • Measure the voltage at lamp 1 using the correct meter (see Section 8).
Step 12	Press and Hold the Transmit button/key, then Press * . <ul style="list-style-type: none"> • The SSCC 1 Lamp Menu is selected.
Step 13	Release the Transmit button. <ul style="list-style-type: none"> • The new lamp 1 voltage value is saved. The lamp 1 output is turned off. The SSCC 1 Lamp Menu options are announced: • “Lamp 1 press 1” • “Lamp 2 press 2” • “Lamp 1 voltage press 3” • “Lamp 2 voltage press 4”
Step 14	Press and Hold the Transmit button. Then Press 4 .
Step 15	Release the Transmit button. “SSCC 1 lamp 2 voltage ___ volts” is announced
Step 16	Press and hold the Transmit button/key, then Press * . <ul style="list-style-type: none"> • The SSCC 1 Lamp 2 Voltage Menu is selected.

Table 63: Remote Lamp Voltage Adjustments

Step 17	<p>Release the Transmit button. “SSCC 1 Lamp 2 Voltage” is announced, followed by:</p> <ul style="list-style-type: none"> • “up 1 volt press 1” • “up one-half volt press 2” • “up one-tenth volt press 3” • “down 1 volt press 4” • “down one-half volt press 5” • “down one-tenth volt press 6” • SSCC 1 lamp 2 output is on and steady.
Step 18	<p>Press and hold the Transmit button/key, then press the number required to appropriately increment the voltage level at lamp 2.</p>
Step 19	<p>Release the Transmit button.</p> <ul style="list-style-type: none"> • “SSCC 1 lamp 2 voltage ___ volts” is announced.
Step 20	<p>Repeat steps 18 and 19 until the specified voltage reading is obtained at lamp 2.</p> <ul style="list-style-type: none"> • Measure the voltage at lamp 2 using the correct meter (see Section 8).
Step 21	<p>Press and hold the Transmit button/key, then Press *.</p> <ul style="list-style-type: none"> • The SSCC 1 Lamp Menu is selected.
Step 22	<p>Release the Transmit button. The new voltage value is saved and the lamp 1 output is turned off.</p> <p>The SSCC 1 Lamp Menu options are announced:</p> <ul style="list-style-type: none"> • “Lamp 1 press 1” • “Lamp 2 press 2” • “Lamp 1 voltage press 3” • “Lamp 2 voltage press 4”
Step 23	<p>Press and hold the Transmit button/key, then Press *.</p> <ul style="list-style-type: none"> • The SSCC Menu is selected.
Step 24	<p>Release the Transmit button. The SSCC Menu options are announced:</p> <ul style="list-style-type: none"> • “SSCC 1 press 1” • “SSCC 2 press 2” • “Crossing press 3”
Step 25	<p>Press and hold the Transmit button/key, then Press 2.</p>
Step 26	<p>Release the Transmit button. The SSCC 2 Lamp Menu options are announced:</p> <ul style="list-style-type: none"> • “Lamp 1 press 1” • “Lamp 2 press 2” • “Lamp 1 voltage press 3” • “Lamp 2 voltage press 4”
Step 27	<p>Repeat steps 5 through 20 for SSCC 2.</p>

Terminate Remote Calibration

Table 64: Terminate Remote Calibration

Step 1	Repeat all remote procedures for each track module selected in the Remote Calibration steps.
Step 2	To terminate the remote session: <ul style="list-style-type: none">• Press and Hold the Transmit button then press *##.
Step 3	Release the Transmit button. The remote setup is finished
Step 4	Return to the bungalow and check the Status log to ensure that the tracks were correctly calibrated. To access the Status Log, press the History Button on the display, then select Status Log.

REMOTE USER INTERFACE MENU

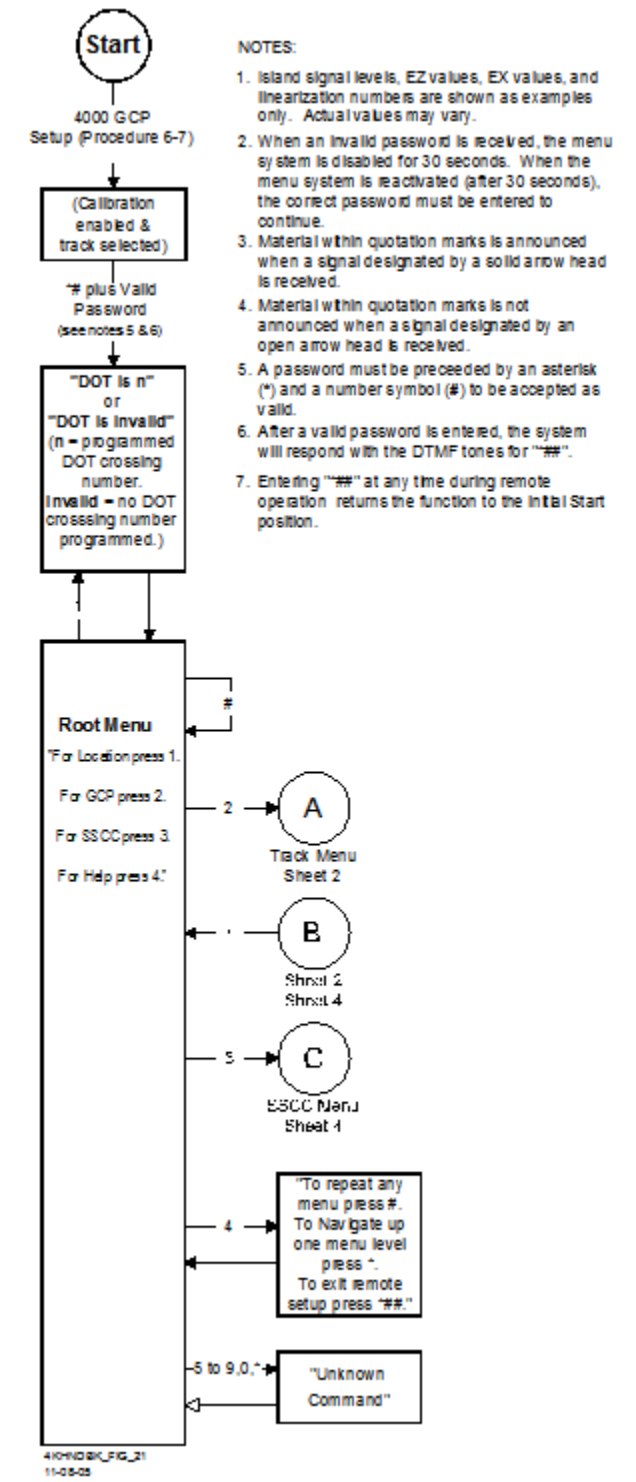

- NOTES:
1. Island signal levels, EZ values, EX values, and linearization numbers are shown as examples only. Actual values may vary.
 2. When an invalid password is received, the menu system is disabled for 30 seconds. When the menu system is reactivated (after 30 seconds), the correct password must be entered to continue.
 3. Material within quotation marks is announced when a signal designated by a solid arrow head is received.
 4. Material within quotation marks is not announced when a signal designated by an open arrow head is received.
 5. A password must be preceded by an asterisk (*) and a number symbol (#) to be accepted as valid.
 6. After a valid password is entered, the system will respond with the DTMF tones for "##".
 7. Entering "##" at any time during remote operation returns the function to the initial Start position.

Figure 39: Remote User Interface Menu, Sheet 1

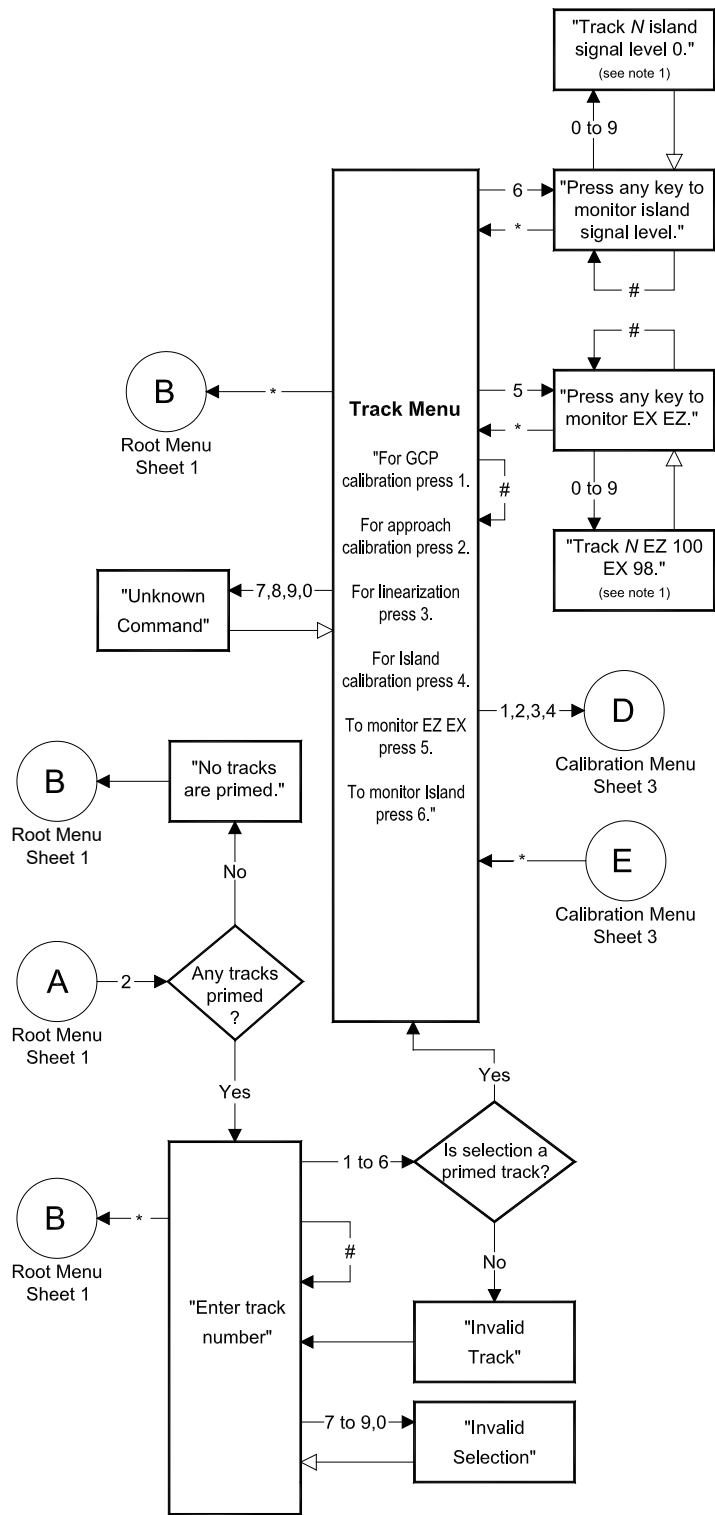

Figure 40: Remote User Interface Menu, Sheet 2

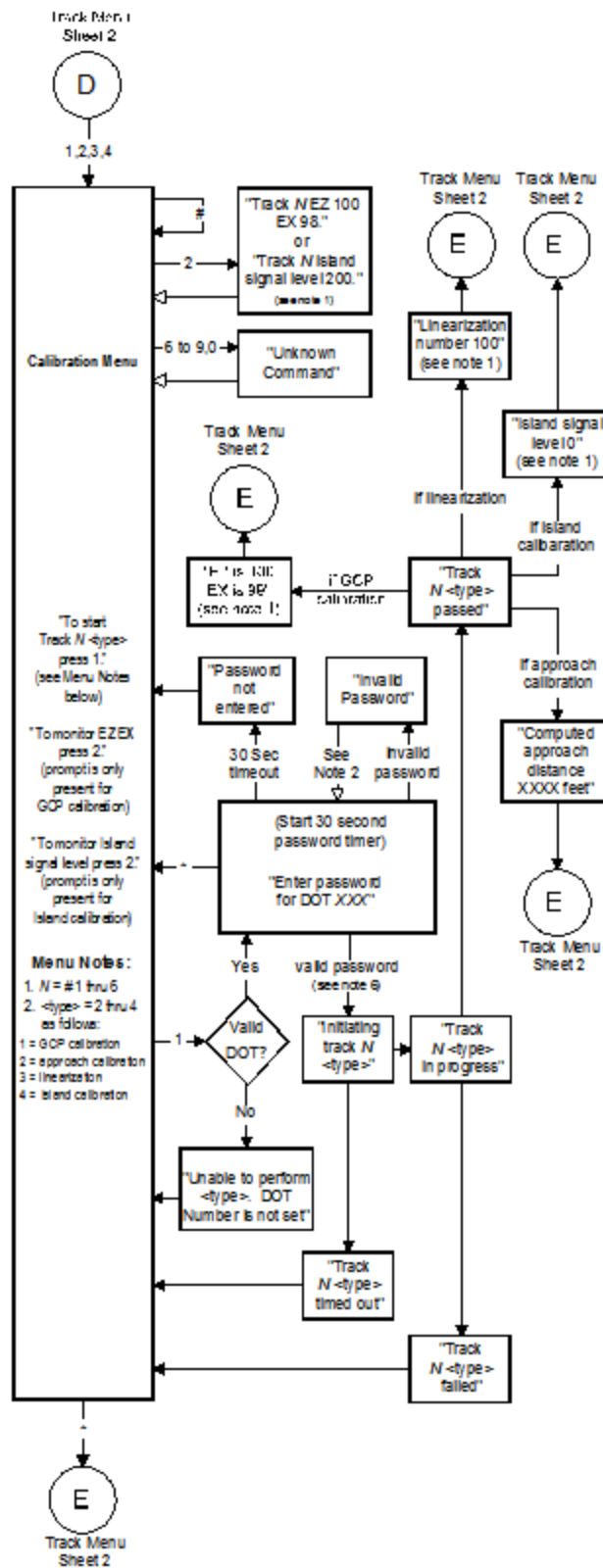

Figure 41: Remote User Interface Menu, Sheet 3

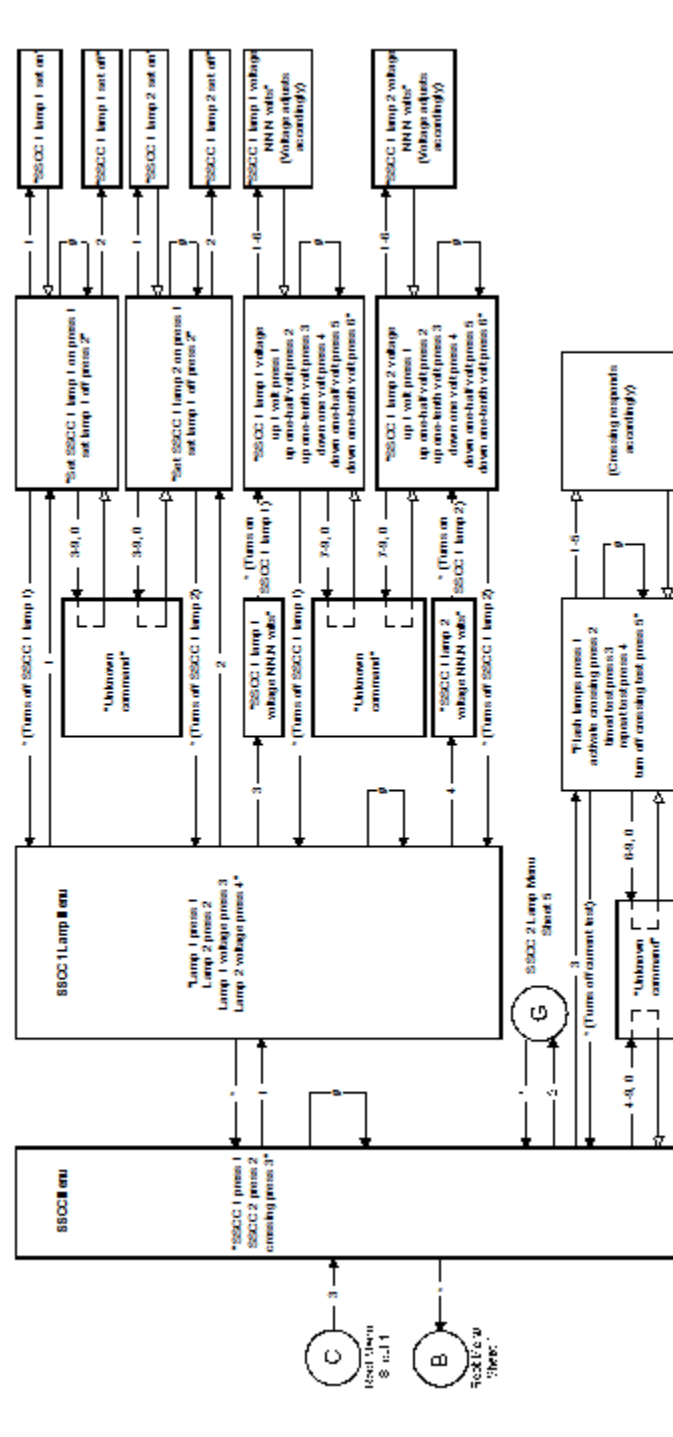

Figure 42: Remote User Interface Menu, Sheet 4

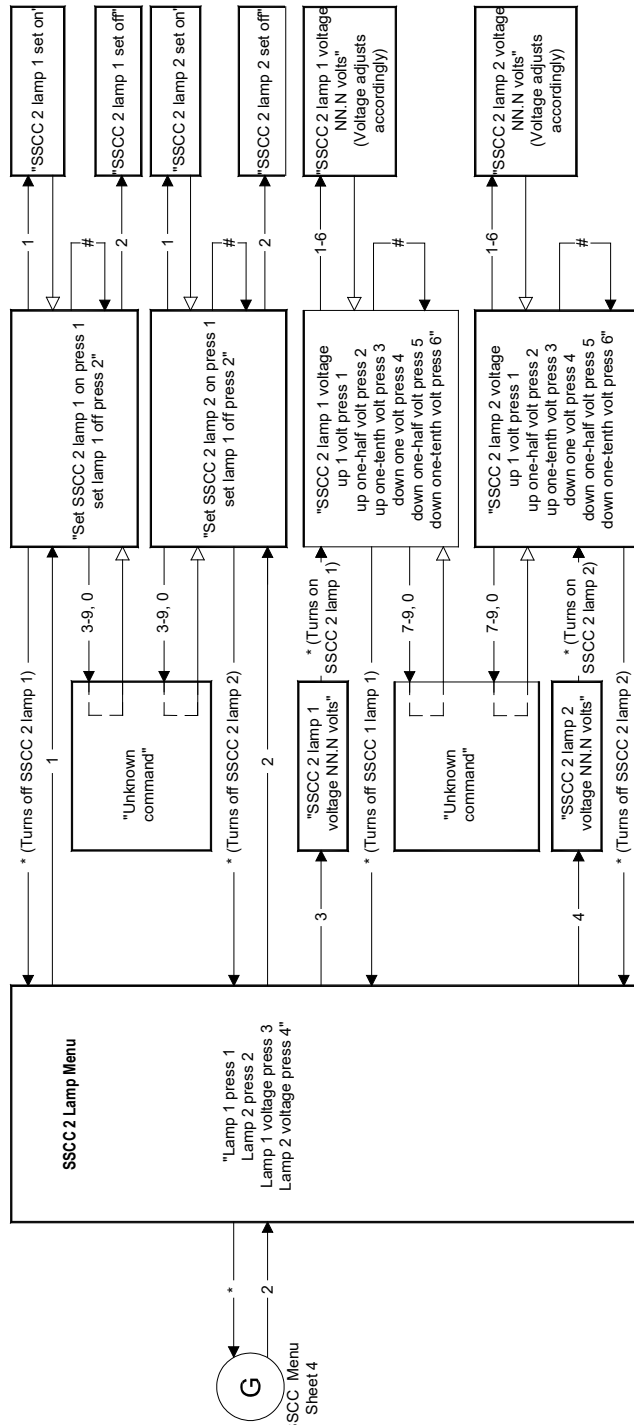

Figure 43 Remote User Interface Menu, Sheet 5

APPENDIX C – INSTALLATION OF FERRITE BEADS

⚠ WARNING

IF ANY GCP TRACK CIRCUIT HAS AN ACTIVE INTERNAL ISLAND, THE GCP 4000 CHASSIS MUST HAVE FERRITE BEADS INSTALLED ON THE TRACK XMT AND RCV WIRES AS DESCRIBED IN BELOW IN ORDER TO AVOID POSSIBLE SHUNTING ISSUES IF A REV D OR EARLIER A80418 TRACK MODULE IS INSTALLED IN CHASSIS.

⚠ CAUTION

CAUTION

PRIOR TO INSTALLATION OF THE FERRITE BEADS, RECORD EZ/EX AND ISLAND Z VALUES FOR THE ACTIVE TRACK MODULES WHERE FERRITE BEADS ARE TO BE INSTALLED; THESE VALUES SHOULD BE RECORDED WITH THE GCP APPROACH CLEAR.

The following guidelines are for the application of Ferrite Beads to the transmitter (XMT1/XMT2) and receiver (RCV1/RCV2) wires [not the check wires] of an affected GCP that incorporates an internal island circuit. The ferrite beads shall be installed on all track slots at the termination point of the XMT1/XMT2 and RCV1/RCV2 wires on the GCP chassis as shown in Figure 44. There are two different sizes of ferrite beads. The smaller of the two is to be installed on the transmitter [XMT1/XMT2] wires. The larger of the two is to be installed on the receiver [RCV1/RCV2] wires.

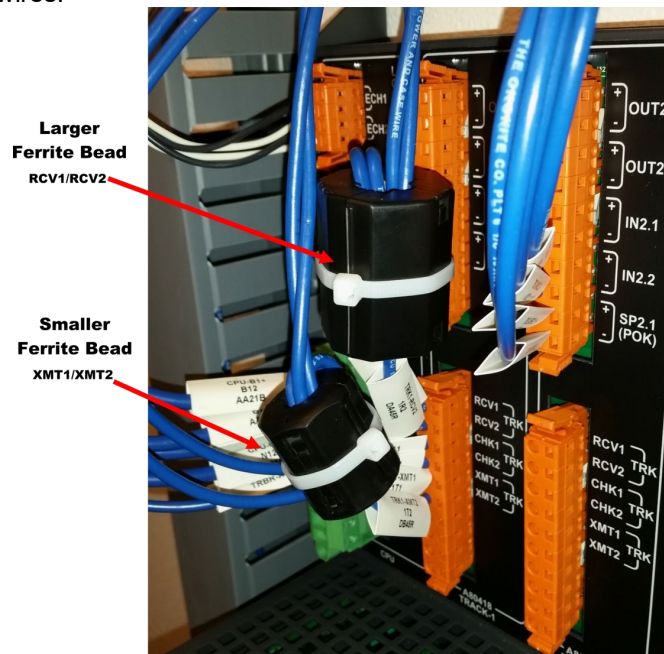

Figure 44: Ferrite Bead Sizes

The ferrite beads require a single wrap of the wires [XMT1/XMT2] [RCV1/RCV2] around the ferrite bead before securing the transmitter or receiver wires to the WAGO connector as shown in Figure 45. The ferrite beads should be installed within two to three inches of the WAGO connector. The sleeve tag can be used as a reference to determine this distance as shown in. Close the ferrite bead, ensuring the securing tabs have properly seated and have snapped into the locked position. Once ferrite bead is installed, a zip tie can be used to secure the ferrite bead and wires in place, preventing movement and the unintentional opening of the ferrite bead.

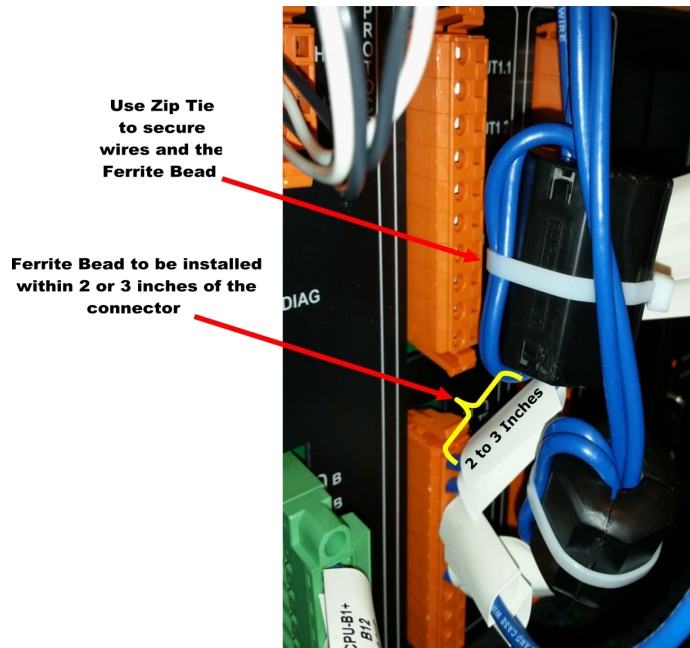

Figure 45: Ferrite Bead Installation Guide

CAUTION

CAUTION
WITH FERRITE BEADS INSTALLED, AGAIN RECORD EZ/EX AND ISLAND Z VALUES OF ACTIVE TRACK MODULES [WITH APPROACH CLEAR] AND COMPARE TO READINGS RECORDED PREVIOUSLY. VALUES SHOULD DIFFER NO GREATER THAN 3 POINTS BETWEEN THE TWO RECORDED VALUES.

The installation of ferrite beads on the GCP does not require any re-calibration of the track circuits and has no effect in the GCP's ability to detect trains. The installation of ferrite beads is compatible with all hardware revisions of the 80418 Track Module.

Ferrite Bead Kit Ordering Information

A Ferrite Bead Kit for the 80418 Track Card will be provided by Siemens.

Table 65: Ferrite Bead Ordering Information

Part Number	Revision	Description
K80418-1	A	Kit, CSB 3-15E, 80418 Track Card

For additional kits contact Siemens Customer Service at (800) 626-2710

For technical assistance please contact Siemens Mobility Technical Support at (800) 793-7233 Option 1.

APPENDIX D – GLOSSARY

GLOSSARY

Advance Preemption:	Notification of an approaching train is forwarded to the highway traffic signal controller by railroad equipment in advance of activating the railroad active warning devices.
Advance Preemption Time:	This period of time is the difference in the Maximum Preemption Time required for highway traffic signal operation and the Minimum Warning Time needed for railroad operation.
AND:	AND circuits require all inputs to be energized for the output to be energized.
AND ENABLE:	An internal function that can be used to 'connect' an input to an AND circuit.
AND 1 XR:	The AND function that controls the local crossing. Is equivalent to the XR relay.
AND 2 thru 8:	Internal functions that are used to combine inputs.
Approach Clear EZ Value	The EZ value setting that is programmed to keep a directional stick set during Bidirectional DAX (BIDAX) operations; the directional stick is held while the train exits the approach. The Approach Clear EZ is set where the BIDAX system's approach terminates in the outer approach of the adjacent bi-directional DAX system.
Approach Clear Time	The length of time, measured in seconds, that is set in Bidirectional DAX (BIDAX) operations that allows the directional stick to be held until the maximum speed train clears the bidirectional approach.
ATCS:	Advanced Train Control System – An industry standard used in the 4000 GCP for communications.
BIDAX	Bidirectional Downstream Adjacent Crossing
BIDAX TO RX	Programming window used when the PSO track connections are located on the Receive side of the crossing.
BIDAX TO TX	Programming window used when the PSO track connections are located on the Transmit side of the crossing.
CCN:	Configuration Check Number – The 32 bit CRC of the configuration data.
CDL:	Control Descriptor Language – The programming language used by application engineers to customize the operation, settings, and behavior of a SEAR II/III.
CHK:	CHECK receiver on a track module connected to transmit wires that perform track wire integrity checks.

GLOSSARY

CHK EZ:	Check EZ is a signal value compared to main receiver EZ that is useful in troubleshooting.
CIC:	Chassis Identification Chip - A non-volatile memory chip that is installed adjacent to the ECD on the GCP backplane. Stores site specific information for both Main and Standby operations.
Computed Approach Distance:	The track approach length calculated by the GCP. The calculated distance between the wire connections on the rail and the termination shunt connections.
CP:	Communications Processor – One of two microprocessors on the CPU11+ or CPU 111 modules, processes external communications for the GCP 4000.
CRC:	Cyclical Redundancy Check - Used to determine that data has not been corrupted.
CRTU:	Cellular Remote Telemetry Unit
DAX:	Acronym for Downstream Adjacent Crossing (Xing). DAX outputs are used to send prediction information from an upstream GCP to a downstream GCP when insulated joints are in the approach circuit.
DAX Direction	The software parameter that tells the system which direction to transmit the DAX signal in BIDAX applications, i.e., to the TX side or to the RX side of the crossing.
DIAG:	Diagnostic
Directionally Wired	Setting used to enable the GCP to determine train direction.
Directional Stick Logic	The logic function used to determine direction of train movement. The output of this function is used to activate/deactivate associated signal systems.
DOT Number:	Department Of Transportation crossing inventory number assigned to every highway-railroad crossing that consists of six numbers with an alpha suffix.
Download	A download is an operation that transfers significant information from the GCP and writes it to the USB drive.
Drop Delay	An internal delay time between when a function is ordered off and when it actually de-energizes.
DT:	Diagnostic Terminal – The Diagnostic Terminal (DT) is a Siemens Rail developed Windows® based software that can run on the Display Module or on a PC, which allows the user to perform programming, calibration, and troubleshooting.

GLOSSARY

DTMF:	Dual Tone Multi-Frequency - The tones on a telephone or radio keypad.
ECD:	External Configuration Device – The non-volatile memory device on the GCP backplane used for storing the module configuration file.
Echelon:	A Local Area Network, LAN, used by the 4000 GCP.
EGOM	Exit Gate Operating Mode – A dynamic mode in which the exit gate operation is based on the presence and detection of vehicles between the stop bar or entrance gate and the exit gate.
Enhanced Detection:	User selectable process that detects nonlinear fluctuations in track signal due to poor shunting and temporarily switches the track module from predictor to motion sensor. Also referred to as IPS, Inbound Poor Shunting
Entrance Gate:	A gate used at the entrance to a highway-railroad grade crossing, which is designed to release and lower by gravity from the full vertical position to the horizontal position under a loss of power condition or when the control energy (GC) is removed.
EX:	The EX value is a numerical indication of track ballast conditions relative to the leakage resistance between the rails. A value of 100 represents nominal good ballast. A value of 39 represents very poor ballast.
Exit Gate:	A gate used at the exit from a highway-railroad grade crossing with Four Quadrant Gates to restrict wrong direction vehicular movements, which is designed to raise by gravity from the horizontal position to a vertical position great enough to allow vehicle clearing under a loss of power condition or when the control energy (GC) is removed.
FAR GATE:	On the same surge panel, the 'far gate' is the flashing light signal or gate with the largest voltage drop in the cable circuit. In general, if both signals have the same number and type of lamps and the same size cable conductors, the 'far gate' is the location with the longest cable run. The 'far gate' circuit on the surge panel does not have an adjustable resistor in series with L1 and L2 that provides voltage adjustment.
Field Password	The password set that allows field maintenance personnel access to field editable parameters.
Flash Memory:	A type of non-volatile memory that can be reprogrammed in-circuit via software.

GLOSSARY

Gate Delay Period:	The programmable time period from when the lights begin to flash until the gates begin to descend.
GC:	Gate Control
GCP:	Grade Crossing Predictor – A train detection device used as part of a highway-railroad grade crossing warning system to provide a relatively uniform warning time.
GCP APP:	GCP Approach length calibration into a hardwire shunt located at the termination shunt.
GCP CAL:	GCP Calibration into a termination shunt.
GCP LIN:	Approach Linearization calibration into a hardwire shunt located at the 50% point on the approach.
GD:	Gate Down, input energized when gate arm is horizontal.
GFT:	Ground Fault Tester – An optional external device connected to the Echelon LAN that constantly monitors up to two batteries for ground faults and indicates battery status to the SEAR IIIi.
GP:	Gate Position – Input energized when gate is vertical.
GU:	Gate Up – Used in a user defined SEAR IIIi application program, (the same as GP).
Highway-Railroad Grade Crossing Advance Warning Sign:	A traffic control sign (round yellow sign with RR and a black X) placed by the highway agency in advance of many highway-railroad grade crossings
Healthy:	The GCP system, modules and track circuit are operating as intended. Health is generally indicated by a yellow LED flashing at 1 Hz (approximately the same flash rate as the FLASH SYNC on a controller or a flashing light signal). Unhealthy conditions are indicated by faster flash rates (2 Hz and 4 Hz) or a dark Health LED.
Hz:	Hertz – Common reference for cycles per second or flashes per second.
iLOD:	Intelligent Light Out Detector – used for measuring lamp current.
Interconnection:	The electrical connection between the railroad active warning system and the traffic signal controller for the purpose of preemption.
IO or I/O:	Input/Output
IPS	Inbound Poor Shunting, see Enhanced Detection
ISL:	Island
ISL CAL:	Island calibration

GLOSSARY

KHz:	Kilohertz – 1000 Hz or 1000 cycles per second.
LAMP 1 VOLTAGE:	Voltage on 1L1 or 2L1 lamp output of the crossing controller module, SSCC IIIi.
LAMP 2 VOLTAGE:	Voltage on the lamp 1L2 or 2L2 lamp output of the crossing controller module, SSCC IIIi.
LAN:	Local Area Network – A limited network where the data transfer medium is generally wires or cable.
Linearization:	The linearization procedure compensates for lumped loads in the GCP approach that affects the linearity (slope) of EZ over the length of the approach.
Linearization Steps:	A calibration value that allows the GCP to compensate for non-linear EZ values within the approach circuit.
LOS:	Loss of Shunt – Commonly due to rust and / or rail contamination. LOS timers provide a pick up delay function.
Lumped Load:	A section of track that has a lower ballast resistance than the rest of the approach because of switches, crossings, contamination, etc.
MAIN:	The primary GCP Modules (CPU, Track, and RIO Modules) that are in a dual GCP chassis.
MBT:	Abbreviation for Master Boot file
MCF:	Module Configuration File – The GCP application logic file.
MEF:	Module Executable File – The GCP executive software program.
MS:	Motion Sensor – A train detection device used as part of a highway-railroad grade crossing warning system to provide a detection of a train approach.
MTSS:	Mini Trackage Sensor – A device located in the gate mechanism that combines input information from gate contacts, bell, and gate tip sensor and sends the information to the SEAR IIIi.
NEAR GATE:	On the same surge panel, the 'near gate' is the flashing light signal or gate with the lowest voltage drop in the cable circuit. In general, if both signals have the same number and type of lamps and the same size cable conductors, the 'near gate' is the location with the shortest cable run. The 'near gate' circuit on the surge panel has an adjustable resistor in series with L1 and L2 that provides additional voltage adjustment.
OCCN:	Office Configuration Check Number – The 32 bit CRC of the configuration data, excluding items that are protected by the Field Password.

GLOSSARY

OCE:	Office Configuration Editor – The PC version of the DT that can be used to create configuration package files (Pac files) for the GCP 4000 system. DT is only compatible with CPU II+ operation. Use of WebUI required if product being used with a CPU III A80903.
Offset Distance:	The distance between the track circuit connections of the remote GCP (sending DAX information) to the island track connections of the UAX GCP (receiving the information).
Out Of Service:	The process for taking one or more GCP approach circuits and / or approach and island circuits out of service.
PAC File:	A GCP 4000 configuration Package File that can either be created in the office using the OCE, or downloaded from a GCP 4000 system via the CP.
PCN	PSO Check Number (PCN) is used to track changes due to re-calibration and adjustments made to key PSO setup variables.
Pick Up Delay:	An internal delay time between when an input receives the signal to pick up and when it actually responds.
POK:	Power Off Indication
Positive Start:	Activate crossing devices when EZ level is less than a programmed value.
Preemption:	The transfer of normal operation of traffic signals to a special control mode.
PRIME:	PRIME may be de-energized by a Track's prime predictor, UAX, advance preempt, and/or island, if zero offset is selected.
PSO-II, PSO-III, PSO4000:	Different models of Siemens Mobility's Phase Shift Overlay – a track circuit (transmitter at one location and receiver at another location) that supplies track occupancy information for crossing warning devices and other train or vehicle detection systems.
RADIO DAX:	DAX information transmitted via Spread Spectrum Radio or other communications devices.
RIO:	Relay Input Output Module
RS232:	Industry standard serial port.
RTU:	Remote Telemetry Unit
RX:	Receive
RX Wire Side Connection	Used in multiple BIDAX operation. This setting enables the system to transmit DAX signals to the Receive Wire side of the crossing.
SEAR Ili Application Program:	Programming for SEAR Ili that controls alarms.

GLOSSARY

Simultaneous Preemption:	Notification of an approaching train is forwarded to the highway traffic signal controller unit or assembly and railroad active warning devices at the same time.
SIN:	Site (Subnode) Identification Number - A twelve-digit ATCS address representing the module as a subnode on the network.
Spread Spectrum:	A method of radio transmission in which the transmitted energy is evenly spread over the complete bandwidth of the radio, resulting in a low RF profile.
SSCC:	Solid State Crossing Controller
SSR:	Spread Spectrum Radio – A radio that utilizes spread spectrum transmission.
Standby:	The GCP Backup Modules (e.g., CPU, Track, and RIO modules) that are in a dual GCP chassis.
Stick EZ	The value below which a BIDAX output or Occupation Code (Code C) is transmitted after prediction has begun.
Stick Release Time	The length of time, measured in minutes, that is set in Bidirectional DAX (BIDAX) operations that allows the directional stick to be held while the train is on the approach.
Supervisor Password	The password set that allows application design personnel access to office editable parameters.
TCN	Track Check Number (TCN) is used to track changes due to re-calibration and adjustments made to key Track Modules specific setup variables.
True RMS AC+DC:	A scale on a multimeter that measures the effective combined AC and DC portions of the total voltage. Used to measure the pulsed output of a crossing controller.
TX:	Transmit
TX Wire Side Connection	Used in multiple BIDAX operation. This setting enables the system to transmit DAX signals to the Transmit Wire side of the crossing.
UAX:	Acronym for Upstream Adjacent Crossing (Xing). UAX inputs are used to receive prediction information from an upstream GCP as inputs to a downstream GCP when insulated joints are in the approach circuit.
Upload	An upload is an operation that reads significant information from the USB drive and transfers it to the GCP.
USB Port:	Universal Serial Bus Port
USB Drive:	A memory device that plugs into a USB port which is commonly called flash drive or memory stick.

GLOSSARY

VHF Communicator:	Communications device used for remote operations and calibration as well as data communications.
VLP:	Vital Logic Processor – One of two microprocessors on the CPUIII+ or CPU III modules, processes GCP vital system logic.
WAG	Wayside Access Gateway – The Siemens Mobility A53457 assembly converts Echelon® messages to Ethernet messages allowing Siemens Rail equipment to use Ethernet Spread Spectrum radios A53325 for communications. WAG assembly A53457 also converts Echelon received messages to RS232 messages allowing the system to use modems for communication between Siemens Mobility equipment.
WAMS:	Wayside Alarm Management System – An office based application that communicates with and receives data from specially equipped crossings.
Wrap:	Common reference for a track circuit, or combination of track circuits that extend to or beyond the limits of a GCP approach, which provides train detection. Used to signify that a certain system function is being overridden based upon the state of a vital input.
WebUI	Web User Interface – A programmed application accessible on the Display and CPU III Module Ethernet ports, interfaced with via a standard web browser.
Z Level:	An Island calibration value. A calibrated island will have a nominal Z Level of approximately 250. The Z Level approaches 0 when shunted.

SIEMENS

Siemens Mobility, Inc.
2400 Nelson Miller Parkway
Louisville, Kentucky 40223
(502) 618-8800

Siemens Mobility, Inc.
One Penn Plaza
Suite 1100
New York, NY 10119-1101
1-800-793-SAFE