



ARC PROTECTION DEVICE





Fast arc flash detection

Reyrolle 7XG35 ReyArc

[siemens.com/reyrolle-7xg35](https://www.siemens.com/reyrolle-7xg35)

The Reyrolle 7XG35 Arc Protection device is used in conjunction with P1X optical sensors to provide arc fault protection for medium or low voltage air insulated switchgear. Direct and reflected light produced by arcing faults is rapidly detected resulting in high speed operation. The P1X sensors are connected to the Reyrolle 7XG35 device via fiber optic cables. Integral self-supervision functionality monitors the Reyrolle 7XG35 device, the optical arc sensors and the fiber-optic connecting cables. An optional overcurrent check function can be used to provide secure 2-out-of-2 tripping criteria.

Highlights

-  High speed fault detection, fast operating time - 2 to 7 ms
-  Selective tripping provided by zone configuration
-  Up to four zones of protection
-  Suitable for new switchgear or as a retrofit upgrade to existing installations
-  Easy configuration using the Reydisp Evolution PC tool via USB C interface:
 - Free of charge Reydisp Evolution PC tool
 - Online and offline device configuration

Benefits

- Fast operation time reduces the risk of personnel injury and minimises equipment damage
- Cost-Effective arc protection solution or protection upgrade
- Data storage features - 100 Events and 5 Fault Data records with time stamping
- Real-time status of Sensors, Inputs, Outputs and measured currents
- Straightforward installation:
 - Compact housing
 - DIN rail mounting
 - Detachable wiring connections

Product variants

Reyrolle 7XG35 models:

- 7XG3551 has four AFD sensor inputs
- 7XG3552 has four AFD sensor inputs + four current inputs

Functions and Features

- Arcing faults detected using P1X 'Point' or 'Line' optical sensors
- Continuous self-supervision of the device and connected optical sensors
- Four high-speed binary outputs
- 11 LEDs provide clear indication of operation and alarms
- Optional CT inputs for Phase and earth fault current check functionality 50AFD/50GAFD
- Tripping can be based on arc flash or dual criteria operation - arc flash and overcurrent

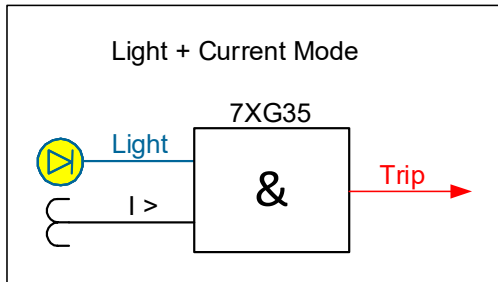

- Circuit breaker failure function (50BF)
- Wide range power supply DC 24 to 240 V and AC 60 to 240 V – single ordering variant

Application

Reyrolle 7XG35 devices and suitably positioned P1X light sensors are used to detect and initiate isolation of faulted plant for arcing faults in the switchgear chambers (busbar, cable termination, CT's etc).

Application example

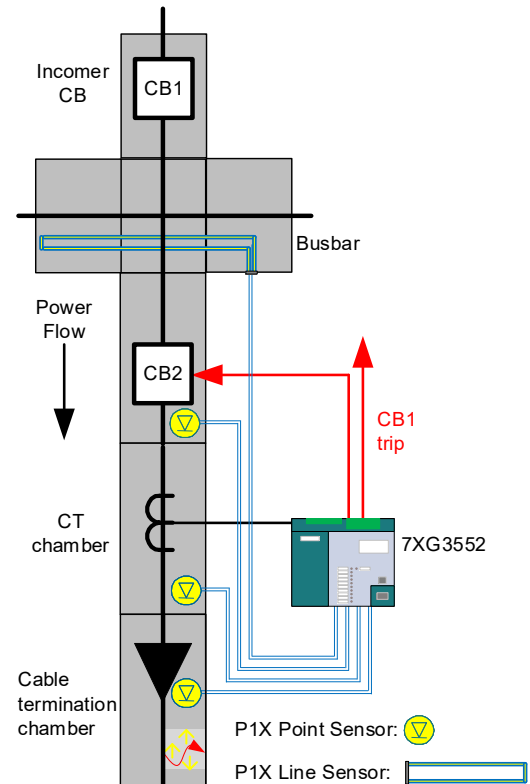

The diagram shows a switchgear section of a radial power system, the direction of power flow is indicated. P1X light sensors fitted in each switchgear chamber and the circuit current transformer (CT) are connected to the device inputs.

When an arcing fault occurs, it is detected via the appropriate sensor. An overcurrent condition must also be confirmed if the 'Light + Current' operate mode is selected. A trip output is issued by the Reyrolle 7XG35 to the relevant circuit breaker (CB).

In the system above an arcing fault is shown in the switchgear cable termination chamber. The fault can be cleared and isolated by tripping CB2. Faults occurring in the busbar chambers can be cleared by tripping CB1 etc. The use of protection zones and assignment of output contacts will ensure selective tripping to disconnect the minimum amount of plant to safely isolate the fault.

Siemens AG
Smart Infrastructure
Electrification & Automation
Mozartstrasse 31c,
91052 Erlangen, Germany

Siemens Industry Inc.
3617 Parkway Lane
Peachtree Corners, GA 30092
United States

[Online Shop - Industry Mall](#)

[Reyrolle 7XG35 ReyArc Catalog](#)

[Reyrolle 7XG35 ReyArc Webpage](#)

© Siemens 2025

Subject to changes and errors. The information given in this document only contains general descriptions and/or performance features which may not always specifically reflect those described, or which may undergo modification in the course of further development of the products. The requested performance features are binding only when they are expressly agreed upon in the concluded contract. For all products using security features of OpenSSL, the following shall apply: This product includes software developed by the OpenSSL Project for use in the OpenSSL Toolkit (www.openssl.org), cryptographic software written by Eric Young (eay@cryptsoft.com) and software developed by Bodo Moeller.