

SIEMENS



Document No: 0071

Connector Operations Manual

For Siemens Subsea Connectors & Sensors - Protection, Storage, Shipment, Unpacking, Deployment & Maintenance Instructions

www.siemens.com/energy/connector-operations-manual

CONTROLLED COPY

SIEMENS SUBSEA ELECTRICAL & FIBRE OPTIC CONNECTORS - SIEMENS SUBSEA SENSORS PROTECTION, STORAGE, SHIPMENT, UNPACKING, DEPLOYMENT & MAINTENANCE INSTRUCTIONS

General

Thank you for purchasing a Siemens Subsea product. The information that follows is an overview of the protection, storage, shipment; unpacking; deployment and maintenance instructions for Siemens Subsea electrical and fibre optic products.

Siemens Subsea recommends the termination of all equipment only be undertaken by suitably trained and qualified personnel.

Revision Details:

Rev 10	Section 6.4.6; 'Mating / De-Mating of ROV connectors by Diver' sub-section added. AquaTRON Hose added to section 2, 'inside' added to bend radii, -30°C changed to -40°C sect 5.3, Storage temp range added to sect 6.3.3, Technical info added to sect 6.6 & chemical compatibility note added.	10/05/06	M. Chilton	M. Simmonds
		22/05/06	S. Troughton	B. Leach
Rev 11	Section 6.4.6 'Alignment and Mating Technique' – "the mating stroke..." sentence added. Section 6.4.6 'Post Mating Checks' sub-section and figure 6 added. Subsequent figure numbers also updated.	04/07/06	M. Chilton	M. Simmonds
Rev 12	Section 3: Gorilla hose specification added Section 4: Note on removal of hoses added Section 5.3: Storage period guidelines expanded	26/09/06	N. Herrington	B. Leach
Rev 13	Section 6.4.4 Additional power washing notes and figure 5A added	09/03/07	C. Burrow	M. Simmonds
Rev 14	Section 5.3.4 'Resistive loads' – Demate speed changed to 40 – 60mm/sec. Sections 5.3.8, 5.3.9 & 5.3.10 – Bulkhead Connectors section added. Section numbers altered to move GENERAL to title.	03/01/08	J. Bostock	S. Kelly
Rev 15	Section 5.3.9 Demate speed changed from 5 M/Sec to 40-60mm/Sec	17/09/08	S. Kelly	B. Leach
Rev 16	Section 6.0 added. Updated to amend updated figures.	28/4/09	J. Bostock	B. Leach
Rev 17	Added trademark information	17/7/09	M.Marklove	B.Leach

Rev 18	Max storage temperature to take solar gain into account (DigiTRON & Mini 'CE')	16/12/09	R. Morrison	B. Leach
Rev 19	ElecTRON section of manual updated.	26/04/10	D. Muldoon-Smith	S. Kelly
Rev 20	Storage of elastomeric components document reference added.	14/5/10	B. Leach	S. Kelly
Rev 21	English version new cover, in Portuguese version grammar mistakes corrected.	03/12/12	C. Santos	H. Parente
Rev 22	New Front cover 1.0 – add product safety to scope 2.0 – Incorporate HSE & Product safety information 7.0 – Information & Note table	25/03/14	M. Gretton	B. Leach
Rev 23	New corporate Front Cover design 2.0 - Receptacle comment added.	7/05/14	M. Gretton	B. Leach

Contents

1.	SCOPE	7
2.	HEALTH & SAFETY	7
3.	PROTECTION, HANDLING AND SHIPMENT	8
4.	UNPACKING	8
5.	STORAGE	9
5.1	Short Term Connector Storage	9
5.2	Long Term Connector Storage	9
5.3	AquaTRON Oil Tube Storage.....	9
5.4	Long term storage of elastomers	9
6.	DEPLOYMENT & MAINTENANCE.....	10
6.1	EEXD Connectors	11
6.2	Seawater Environment 'SE' Connector	12
6.3	Controlled Environment Mini 'CE' Connectors	14
6.3.1	General	14
6.3.2	Mini 'CE' Electrical and Mechanical Specification:	15
6.3.3	Live Mate / Demate.....	16
6.3.4	Protection of Receptacle Contact Pins	16
6.3.5	Over Current Capacity	16
6.3.6	Removal of Marine Growth and Calcareous Deposits	17
6.3.7	Diver Mate Connectors	17
6.3.8	Stab Plate Connectors.....	18
6.3.9	ROV Connectors.....	19
6.4	SPECTRON Power Connectors	21
6.4.1	General	21
6.4.2	Protection of Receptacle Contact Pins	22
6.4.3	Over current Capacity	22
6.4.4	Removal of Marine Growth and Calcareous Deposits	22
6.4.5	Stab Plate Connectors.....	23
6.4.6	ROV Connectors.....	24
6.5	ElectRON Instrumentation Connectors	26
6.5.1	General	26
6.5.2	Protection of Receptacle Contact Pins	27
6.5.3	Removal of Marine Growth and Calcareous Deposits	27
6.5.4	Stab Plate Connectors.....	28
6.6	AquaTRON Oil Tube Harnesses	29
6.7	Cable Harnesses / Glanded Connectors	29
6.8	Electro Optic (FoeTRON) Connectors	30
6.8.1	General	30
6.8.2	FoeTRON Electrical, Optical and Mechanical Specification.....	31
6.8.3	Live Mate / Demate.....	32
6.8.4	Over Current Capacity	32
6.8.5	Removal of Marine Growth and Calcareous Deposits	32
6.8.6	Diver Mate Connectors	33
6.8.7	Stab Plate Connectors.....	34
6.8.8	ROV Connectors.....	35
7.	SIEMENS SUBSEA SENSOR DEPLOYMENT & MAINTENANCE	37
7.1	PACKING.....	37
7.2	UNPACKING.....	37

7.3	STORAGE	37
7.4	CRITERIA FOR PRESERVATION	38
7.5	HANDLING	38
7.6	SHIPPING AND MARKING.....	38
7.7	STACK LIMITATION	38
7.8	TRANSPORTATION CRATE	39
8.	INFORMATION AND NOTES / HEALTH & SAFETY FEEDBACK.....	41

1. SCOPE

This procedure includes information on the following connector types:

- EEXD
- Seawater Environment 'SE'
- Controlled Environment Mini 'CE'
- SpecTRON (Power)
- ElecTRON (Instrumentation)
- FoeTRON (Fibre Optical)
- AquaTRON Hose
- Siemens Subsea Sensors

Sections 2, 3 & 4 detail general information applicable to all Siemens Subsea connectors. Section 6 then provides specific information relevant to Siemens Subsea Sensors.

Any information, records or Health and Safety feedback that needs to be detailed, can be recorded in the punch list at the rear of the document

2. HEALTH & SAFETY

Manual Handling, Lifting and Carrying are known to be the largest contributors to occupational ill-health.

Ensure that mechanical handling aids are used whenever possible to avoid manual handling. Where manual handling is considered appropriate for the task safe lifting guidelines must be followed, e.g. adopt correct posture, consider team lifting, employ safe lifting technique, etc. Only competent persons are permitted to perform tasks without supervision, if in doubt ask. Good Housekeeping avoids Slips Trips and Falls, keep your area clean and tidy. It is the operator's responsibility to comply with current Company & regional health and safety legislation.

Caution shall be exercised during assembly to ensure that fittings and hydraulic / pneumatic equipment are properly installed.

In the event of a safety incident or any safety improvement suggestions, please contact the Health & Safety Department at prodsafe.gb@siemens.com and/or complete and return the punch list in section 7.0.

Note – All receptacle's (male pins) must be mated to its correct mating half before it is energised (this includes the correct Test, Dummy and Wet Mate Pair).

3. PROTECTION, HANDLING AND SHIPMENT

Siemens Subsea electrical connectors are manufactured primarily from materials such as 316L stainless steel (UNS S31603), and Super Duplex stainless steel (UNS S32550), and as such are designed to withstand harsh saliferous environments. However, the connector insert and exposed parts are susceptible to mechanical damage if not adequately protected. Dust caps are fitted to all Siemens Subsea connectors before transport, but can be fitted with protective caps if specified by the customer. Caps are recommended to remain in place until connectors are deployed subsea.

The connectors are generally relatively small items of equipment, and therefore, can be shipped singularly or in multiples. Care should be taken to protect the connector with bubble wrap or similar wrapping materials to avoid surface damage during transit. If large numbers are shipped in one consignment a suitably reinforced box will be necessary to withstand the weight. Protection caps must be fitted at all times during transport.

If storage is carried out in saline conditions, e.g. on a ship's deck or hold, then full dummy connectors should be used.

Bulkhead type connectors with exposed tailing wires should be packed and shipped in a suitably sized box to allow adequate space for the tailing wires without bending or kinking.

If the connectors are assembled onto hoses these must be suitably coiled and secured with tape to prevent uncoiling during transit. The following bend radii are recommended for storage/transport of hoses.

- AquaTRON 50, TC6A-700 – Minimum inside bend radii - 125mm
- AquaTRON 75, TC6A-712 – Minimum inside bend radii - 180mm
- AquaTRON 2", TC6A-701 - Minimum bend radii - 375mm
- Synflex hose, Ref 3E80E 1/2NB - Minimum bend radii – 250mm
- Griflex Polyurethane Hose Ref FNP50 1/2NB - Minimum bend radii – 150mm
- Gorilla 1.5" NB – Minimum bend radii – 250mm

Connectors are designed to withstand vibration that occurs during transportation and to withstand being dropped from a height of 1m whilst in packaging.

Any connector-specific handling and transport advice is contained within the appropriate section further on in this document.

4. UNPACKING

Remove wrapping material taking care to inspect for any surface damage or items that may have become separated from the connector, such as 'O' seals. Do not use a knife to cut the wrapping material, as this may cause damage to any elastomeric parts of the connector. Do not remove protection caps until connectors are ready for installation. On removal do not allow the hoses to drag over the edges of the packing crate.

5. STORAGE

5.1 SHORT TERM CONNECTOR STORAGE

Prior to installation the connectors are sensitive to environments where grit and dirt are present. To prevent ingress of the above, they should be stored in a clean dry area and be protected by bubble wrap or similar wrapping material. Protection caps must be fitted if supplied.

Please note: maximum storage temperature takes into account solar gain. Skin temperature must not exceed 70°C. Suitable protection must be used to ensure maximum storage temperature is not exceeded.

5.2 LONG TERM CONNECTOR STORAGE

The connectors must be stored in a clean dry area and be protected by bubble wrap or similar. Suitable protection caps must be fitted (instrumentation connectors require sealed caps), and the storage temperature should be between -40°C and 70°C. Humidity of the store room should be below 75%. Very moist or very dry conditions should be avoided. The Plug connector (and the receptacle connector in the case of FoeTRON products) should be protected from strong sunlight and strong artificial light with a high ultra violet content. Moulded connectors should be placed within black bags to avoid direct sunlight. The connectors should not be allowed to come into contact with solvents, oil, greases or any other semi-solid materials. If glanded connectors are to be stored bolted into their interfaces ensure the cable entry point into the gland is covered to prevent water ingress.

Please note: maximum storage temperature takes into account solar gain. Skin temperature must not exceed 70°C. Suitable protection must be used to ensure maximum storage temperature is not exceeded.

5.3 AQUATRON OIL TUBE STORAGE

Storage temperature range: -40°C to 70°C

Storage humidity: 0% to 85% R.H.

Maximum storage period: 2 years stored in accordance with ISO 2230 (pressurised).

If storage is outside the above guidelines, then protective covering is available on request.

Where Junction Boxes are used ensure protection from strong sunlight and strong artificial light.

5.4 LONG TERM STORAGE OF ELASTOMERS

For the recommended storage of elastomeric components e.g. termination sleeves and cable boots, please refer to Siemens Subsea document MH006 - Procedure for Storage and Handling of Elastomeric Materials.

6. DEPLOYMENT & MAINTENANCE

The following section details deployment and maintenance instructions for all Siemens Subsea connectors & hose, categorised by product type. Please refer to the appropriate section as listed below:

- 5.1 – EEXD Connectors
- 5.2 – Seawater Environment (SE) Connectors
- 5.3 – Mini CE Connectors
- 5.4 – Power Connectors
- 5.5 – Instrumentation Connectors
- 5.6 – AquaTRON Oil Tube Harnesses
- 5.7 – Cable Harnesses / Glanded Connectors
- 5.8 – Electro Optic (FoeTRON) Connectors

All information contained within this section is generic. Where customer or project-specific information is required, please refer to the relevant project specification or scope of supply.

Note: It is important to isolate and earth prior to disconnect in order to remove any stray charges in the system. If left, this can induce corrosion on the exposed pins once the plug is removed.

6.1 EEXD CONNECTORS



Figure 1 - EEXD Connectors

This range of connectors is now unavailable from new but would have been terminated, then deployed within the splash zone or zone 1 hazardous area and used for fast inter-module hook-up. Limited deployment instruction is required with this connector but a few general observations must be followed:

- Cable Bend Radius limitations
- Connector Location
- Cable supports
- Connector mounting details

To maintain EEXD rating, EEXD rated blanking caps must be fitted to unmated connectors.

All mild steel sealing interfaces shall be inlaid with Inconel 625, or similar, where no additional protection (e.g. CP, Paint etc.) can be provided. This is to prevent localised pitting of the interface.

The connector shall have the following periodic maintenance checks:

- Clean the outside of the connector with an isopropanol cleaning spray such as Intersolv IPA. Ensure the fluid does not contact any of the elastomeric materials.
- Examine the connector for signs of damage.
- Check the clamp ring and all other fasteners, these shall be tight, if loose refer to assembly instruction for torque values, where appropriate.

It is recommended that the above checks be performed at the following intervals:

- Offshore Hook-up, 6 months after Hook-up,
- 1 year after Hook-up & every two years thereafter.

6.2 SEAWATER ENVIRONMENT 'SE' CONNECTOR



Figure 2 - SE Plug Connector

This range of connectors can be supplied terminated or loose. All SE connectors require the following acceptance tests during the terminations:

- Gas Leak
- Insulation Resistance
- High Voltage
- Continuity tests

Cable terminations can be performed on-site or offshore by Siemens Subsea trained personnel where the cable cannot easily be moved or transported. Each SE connector is fitted with a pin or socket insert which has been hydrostatically tested and electrically proven prior to despatch. Termination of SE connectors should only be undertaken by trained personnel.

Prior to mating an SE connector, each insulating cone of the pin insert contacts should be smeared with a small amount of 'Tronilube' dielectric grease, in accordance with the instructions on the next page.

All SE connectors must be fitted with a mating connector or a dummy connector prior to subsea installations. Connectors must not be energised subsea unless coupled with a mating connector or fitted with a dummy plug or receptacle, in order to prevent electrolytic damage to the contacts when exposed to sea water.

All mild steel sealing interfaces shall be inlaid with Inconel 625, or similar, where no additional protection (e.g. CP, Paint etc.) can be provided. This is to prevent localised pitting of the interface.

To achieve the highest performance of the 'K' series 'SE' type connectors a tube of TRONILUBE LUBRICATION GREASE is supplied to aid contact sealing during service. Please ensure that the Pin contact green rubber cone seals of the receptacle connector receive a smear of Tronilube (available from Siemens Subsea in 1ml syringes) prior to deployment as shown below.

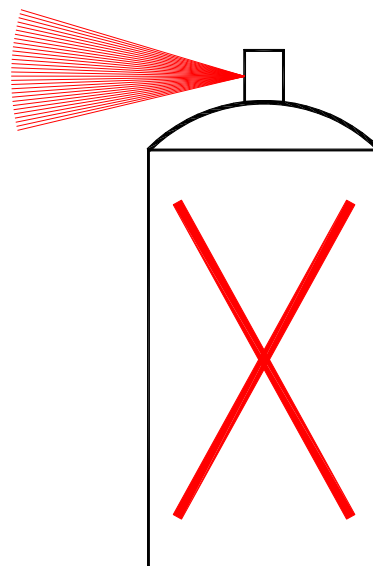
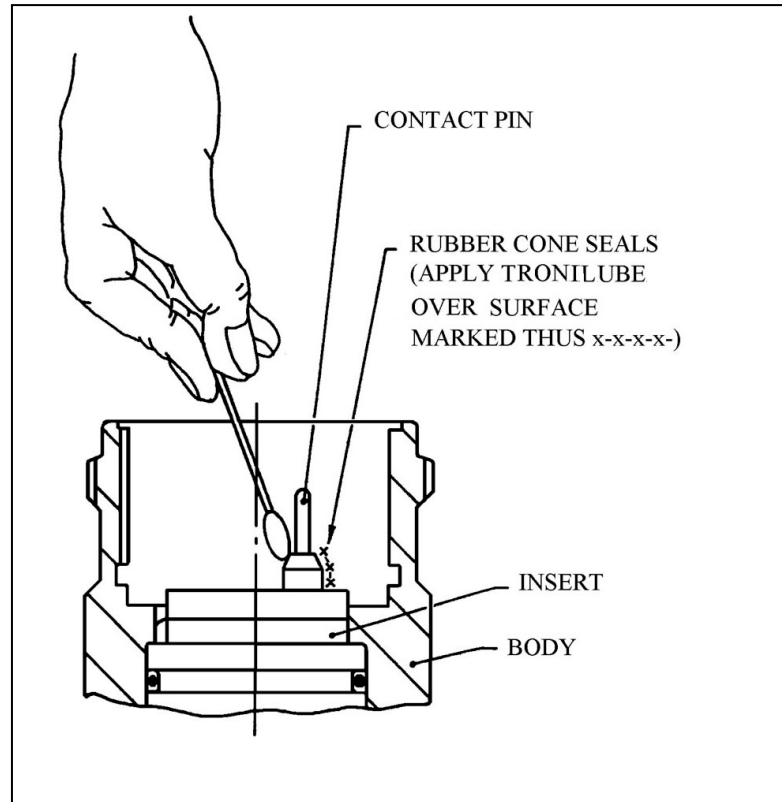

NOTE: DO NOT USE SOLVENTS TO DE-GREASE

6.3 CONTROLLED ENVIRONMENT MINI 'CE' CONNECTORS

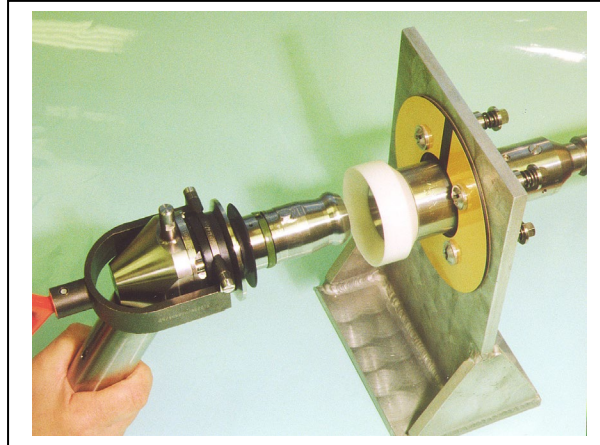

Figure 3: Mini CE ROV Connector

6.3.1 General

The Mini 'CE' range of connectors have been developed for long term reliable signal and low power control system applications associated with offshore installations. The underwater mateable capacity of these connectors is achieved using pressure compensated electrical inserts employing the CE principle.

Connectors are usually supplied with protective caps. The protective caps must be removed prior to mating the connectors.

All mild steel sealing interfaces shall be inlaid with Inconel 625, or similar, where no additional protection (e.g. CP, Paint etc.) can be provided. This is to prevent localised pitting of the interface.

If the connectors are to be left unmated, in seawater, for any length of time dummy connectors must be used to protect the pin contacts in the receptacle connectors. Over exposure will increase the risk of corrosion damage or marine growth on the contact surfaces of the receptacle contact pins. This could lead to damage to the seals and insulation within the socket contacts. Plug connectors do not require full dummy connectors for protection. Siemens Subsea advise the fitting of acetal caps to protect plugs against marine growth. It is good practice to always fit the protective cap when a connector is unmated topside prior to deployment to provide mechanical protection.

NOTE: 28 DAYS IS THE MAXIMUM CUMMULATIVE ALLOWABLE EXPOSURE OF UNPROTECTED CONTACT PINS TO SEAWATER OVER THE LIFE OF THE CONNECTOR. THIS ONLY APPLIES WITH POWER OFF.

The appropriate test connector must always be used to make electrical contact during testing. **UNDER NO CIRCUMSTANCES** should a foreign object (such as a screwdriver, test probe, or crocodile clip) be used as a test connection as this could damage the seals and insulation. Such actions will invalidate the warranty of the connector.

Guide pins must never be removed from test connectors as this can lead to damage and will invalidate the connector warranty.

NOTE: NO PART OF THE CONNECTORS SHOULD BE DISMANTLED PRIOR TO OR DURING DEPLOYMENT, APART FROM THE REMOVAL OF PROTECTIVE CAPS, SINCE THERE ARE NO USER SERVICEABLE PARTS INSIDE.

The Mini 'CE' range of connectors can be supplied either singularly or as part of a harness assembly. All Mini 'CE' connectors require the following during termination:

- Gas Leak
- Insulation Resistance
- High Voltage
- Continuity tests

Cable terminations can be performed on-site or offshore by Siemens Subsea trained personnel where the cable cannot easily be moved or transported. Each Mini CE connector is fitted with a pin or socket insert which has been hydrostatically tested and electrically proven prior to despatch. Termination of these connectors should only be undertaken by trained personnel.

6.3.2 Mini 'CE' Electrical and Mechanical Specification:

- Maximum current (dry & submerged)
 - 3/4-way = 20A
 - 7-way = 20A
 - 9/12-way = 15A
- Maximum working voltage: 1000V rms phase to earth, 1500V rms phase to phase
- Rated number of operations: 100 mate / de-mate cycles (Power off)
- Working pressure: 5000 psi (9840 ft / 3000 metres water depth)
- Working temperature range: 0 to +60°C
- Storage temperature range: -40 to +70°C

Please note; maximum storage temperature takes into account solar gain. Skin temperature must not exceed 70°C. Suitable protection must be used to ensure maximum storage temperature is not exceeded.

6.3.3 Live Mate / Demate

The inserts used in the Mini 'CE' range of connectors are designed to be mated / demated with **POWER OFF**. If, **in exceptional circumstances**, it is necessary to mate / de-mate the connectors with power on, the following should be considered.

- **Resistive loads**

Mating the connectors should not lead to any damage to the sealing mechanisms within the plugs.

The speed of de-mating should be between 40mm/s to 60mm/s. Following this demating procedure, testing should be carried out on the connector to establish if any damage has occurred. Under no circumstances shall connectors be partially mated with power on.

- **Capacitive loads**

Mating with power on will lead to an in-rush current. The magnitude of this in-rush current will depend on the capacitance of the circuit. It is very important that the in-rush current is no more than 500A.

- **Inductive loads**

Mating the connectors should not lead to any damage to the sealing mechanisms within the inserts. De-mating **must not be attempted** as there is a risk of high back EMF's which will cause damage to the seals and insulation within the inserts.

- The maximum number of live mate/demate operations under the above conditions is **one** only.

6.3.4 Protection of Receptacle Contact Pins

Under no circumstances must the contact pins in the receptacle connector be exposed to seawater with power on. If this situation does occur the contact surfaces of the pins will very rapidly degrade by electrolytic action. If these damaged pins are subsequently mated into a socket insert there is a **very high risk** of damage to the insulation and seals within the plug connector.

6.3.5 Over Current Capacity

Over current capacity for all Mini 'CE' connectors is 100A for 5 seconds at no more than 2 per hour.

6.3.6 Removal of Marine Growth and Calcareous Deposits

To remove calcite growth from Siemens Subsea connectors, a solution of 50% Citric Acid is recommended. All Seawater exposed elastomeric materials in Siemens Subsea connectors have been fully tested against 50% Citric Acid and are compatible for duration of 1 hour. In addition, the thermoplastic materials have good resistance to Citric Acid.

Other acid cleaners, such as 50% Acetic Acid, should **not be** used as they may cause deterioration of the elastomeric materials.

Chiselling and abrasive methods are not recommended. Use of a water jet is acceptable, but the jet should not be directed onto the shuttle pins at the front of the plug as this could result in a risk of water being forced through the primary seals.

6.3.7 Diver Mate Connectors

- **Alignment**

These connectors have been designed to self-align during mating. All that is required is to ensure that the alignment pin on the plug connector is engaged in the alignment groove within the receptacle connector before screwing the clamp ring up.

- **Pre Mating Check**

Before mating, the receptacle connector should be checked for debris. The connectors have been designed to accommodate sand and silt contamination, however large pieces of debris should be removed using a water jet.

- **Mating**

The clamp ring should be rotated clockwise by hand until tight. The connectors are designed to remain clamped together with only firm hand tightness on the clamp ring. If a clamping torque is required this **MUST NOT** exceed 15 ft-lbs. [20Nm]. A 2-3" C-spanner or purpose made Siemens Subsea tool (T11367) may be used to apply this torque.

- **Post Mating Checks**

Full engagement of the connectors can be checked through the viewing hole in the clamp ring. If the connectors are fully mated then no gap should be visible between the plug and receptacle.

- **Cathodic Protection**

Stainless steel 316L (UNS S31603) diver mate connectors must be connected to the CP (Cathodic Protection) system at all times. Super Duplex stainless steel (UNS S32550) connectors should be isolated from the CP system to reduce the possibility of hydrogen embrittlement.

- **Bulkhead Connectors**

Bulkhead connectors with pigtail wires terminated should be treated with care, especially around the termination area and the termination area should not be bent. Excessive force should not be used to pull the wires. The connector should not be held or carried using the terminated wires.

6.3.8 Stab Plate Connectors

- **Compliance**

One half of a stab mate connector pair must be allowed to float so that misalignment tolerances can be accommodated.

- **Mate/De-Mate Speed**

The connectors have been designed to operate across a wide range of mate / de-mate speeds with **POWER OFF**. There is no practical limit to the speed at which the connectors may be mated or de-mated, however as a guide: -

- a) Mating speed should not exceed 1 m/s.
- b) De-mating speed should be 40mm/s to 60mm/s.

- **Pre-Mating Checks**

Before mating, the receptacle connector should be checked for debris. The connectors have been designed to accommodate sand and silt contamination, however large pieces of debris should be removed using a water jet.

- **Partial Disconnection**

Partial disconnection with the contact pin remaining between the primary and secondary diaphragms is not recommended, as there is a risk of damaging the insulation. If it is necessary to operate the connectors partially mated, the connectors should be separated by 0.340-0.360" [8,6-9,2mm] from the nominal, mated, stab distance. In this condition the level of insulation between the contact pin and socket contact is reduced and the connector is relying on the primary seals within the plug. There is also an increased risk of insulation break down at voltages above 500V.

- **Interrupted Connection**

Interrupted connection (i.e. Partial mate to full de-mate) can be carried out without any adverse affect to connectors, as long as the power is off.

- **Cathodic Protection:**

Stainless steel 316L (UNS S31603) stab plate connectors must be connected to the CP (Cathodic Protection) system at all times. Super Duplex stainless steel (UNS S32550) connectors should be isolated from the CP system to reduce the possibility of hydrogen embrittlement.

- **Bulkhead Connectors**

Bulkhead connectors with pigtail wires terminated should be treated with care, especially around the termination area and the termination area should not be bent. Excessive force should not be used to pull the wires. The connector should not be held or carried using the terminated wires.

6.3.9 ROV Connectors

- **Alignment**

These connectors have been designed to self align during mating. The connectors must be roughly aligned using the alignment marks on the plug body, flange and receptacle cone. The mounting of the ROV handle has sufficient compliance to accommodate fine adjustments during the final approach prior to connector engagement.

- **Pre Mating Checks:**

Before mating the receptacle connector should be checked for debris. The connectors have been designed to accommodate sand and silt contamination, however large pieces of debris should be removed using a water jet.

- **Mechanical Forces During Mating / De-Mating:**

The connectors have been designed to accommodate over stroking and bending forces to the following limits.

Over-stroking force < 2,205 lbf [9810N]

Bending < 370 ft-lbs. [500Nm]

Torsion < 370 ft-lbs. [500Nm]

- **Maximum Misalignment Values**

The values for maximum misalignment that the MCE ROV connectors can tolerate with mating still possible are as follows.

Misalignment Type	4-way	12-way
Rotational	15	5
Axial	3mm	2mm
Angular	2.5	5

- **Mating / de-mating forces (Mini CE)**

3 & 4 way	Mating	<30 Kgf
	De-mating	30 Kgf ±15%
9 & 12 way	Mating	>50 Kgf
	De-mating	<80 Kgf

- **De-Mating**

De-mating is achieved by a straight pull on the ROV handle sufficient to release the latching mechanism.

- **Mechanical Over-Loading From The ROV**

The maximum bending moment that can be applied to the connectors when mated is 2000Nm before the risk of mechanical damage to the electrical connection becomes significant.

- **Cathodic Protection**

ROV connectors are designed to operate isolated from the CP [Cathodic Protection] system. ROV connectors will not suffer damage by being connected to the CP system, however there will be a tendency for increased calcareous deposits on metal surfaces, and the possibility of hydrogen embrittlement.

- **Bulkhead Connectors**

Bulkhead connectors with pigtail wires terminated should be treated with care, especially around the termination area. Excessive force should not be used to pull the wires and the termination area should not be bent. The connector should not be held or carried using the terminated wires.

6.4 SPECTRON POWER CONNECTORS

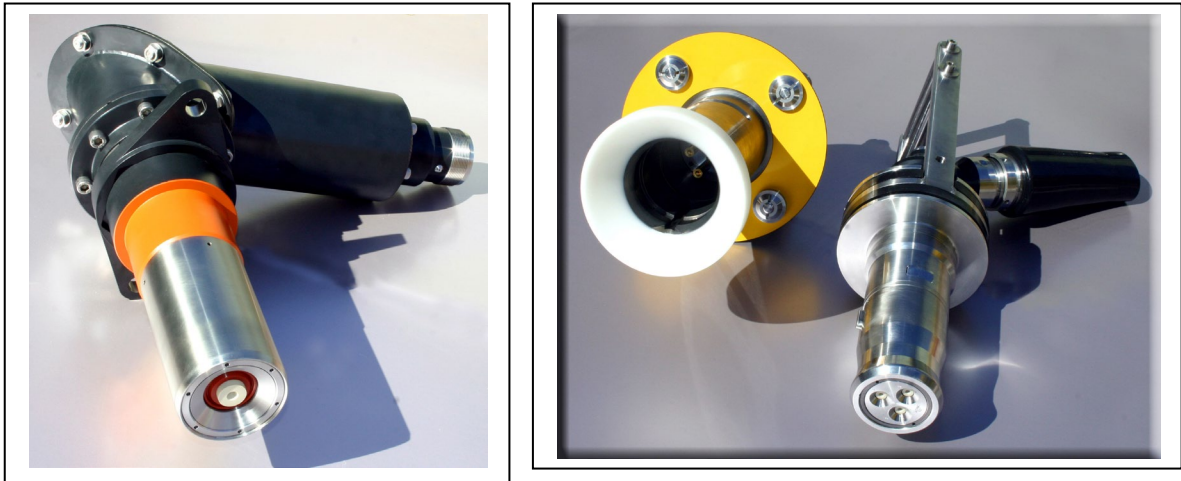

Figure 4 – SPECTRON Power Connectors

6.4.1 General

The SPECTRON range of Power connectors has been developed for long term reliable high power control system applications associated with offshore installations. The underwater mateable capacity of these connectors is achieved using pressure compensated electrical inserts employing the CE principle.

Connectors are usually supplied with protective caps. The protective caps must be removed prior to mating the connectors.

All mild steel sealing interfaces shall be inlaid with Inconel 625, or similar, where no additional protection (e.g. CP, Paint etc.) can be provided. This is to prevent localised pitting of the interface.

If the connectors are to be left unmated, in seawater, for any length of time dummy connectors must be used to protect the pin contacts in the receptacle connectors. Over exposure will increase the risk of corrosion damage or marine growth on the contact surfaces of the receptacle contact pins. This could lead to damage to the seals and insulation within the socket contacts. It is good practice to always fit the protective cap when a connector is unmated topside prior to deployment to provide mechanical protection.

NOTE: 28 DAYS IS THE MAXIMUM CUMMULATIVE ALLOWABLE EXPOSURE OF UNPROTECTED CONTACT PINS TO SEAWATER OVER THE LIFE OF THE CONNECTOR. THIS ONLY APPLIES WITH POWER OFF.

The appropriate test connector must always be used to make electrical contact during testing. **UNDER NO CIRCUMSTANCES** should a foreign object (such as a screwdriver, test probe, or crocodile clip) be used as a test connection as this could damage the seals and insulation. Such actions will invalidate the warranty of the connector.

Guide pins must never be removed from test connectors as this can lead to damage and will invalidate the connector warranty.

NOTE: UNDER NO CIRCUMSTANCES MUST CONNECTORS BE DEMATED WHILST LIVE. NEITHER SHOULD CONNECTORS BE PARTIALLY MATED AND POWER APPLIED.

Refer to project specific data sheets and scope of supply drawings for performance specifications and detailed deployment instructions.

NOTE: NO PART OF THE CONNECTORS SHOULD BE DISMANTLED PRIOR TO OR DURING DEPLOYMENT, APART FROM THE REMOVAL OF PROTECTIVE CAPS, SINCE THERE ARE NO USER SERVICEABLE PARTS INSIDE.

6.4.2 Protection of Receptacle Contact Pins

Under no circumstances must the contact pins in the receptacle connector be exposed to seawater with power on. If this situation does occur the contact surfaces of the pins will very rapidly degrade by electrolytic action. If these damaged pins are subsequently mated into a socket insert there is a **very high risk** of damage to the insulation and seals within the plug connector.

6.4.3 Over current Capacity

Over current capacity varies for each product. Please refer to the product datasheet.

6.4.4 Removal of Marine Growth and Calcareous Deposits

To remove calcite growth from Siemens Subsea connectors, a solution of 50% Citric Acid is recommended. All Seawater exposed elastomeric materials in Siemens Subsea connectors have been fully tested against 50% Citric Acid and are compatible for a duration of 1 hour. In addition, the thermoplastic materials have good resistance to Citric Acid.

Other acid cleaners, such as 50% Acetic Acid, should not be used as they may cause deterioration of the elastomeric materials.

Chiselling and abrasive methods are not recommended. Wiping with a soft, clean cloth is acceptable providing care is taken inside the Receptacle shroud to avoid disturbing the earth continuity contact (i.e., Multilam or Bal spring type), or to impart a bending load on the power pin/s. Use of water jetting for the removal of sand/silt is acceptable given the following limitations:

- All forms of water jet cleaning of connectors in air must be avoided. The likelihood of damage to connectors is great, given the high localised impact velocities of the water jet.
- Submerged water jet cleaning of connectors is acceptable, providing the critical areas identified in Figure 5A are avoided. Particularly, the jet should not be directed at the Plug shuttle pin as this could result in a risk of water being forced through the primary seals and/or front seal. Similarly, the water jet should not be directed into the mouth of the Receptacle shroud as the earth contact could be displaced. Remaining areas indicated below are suitable for submerged water jet cleaning.

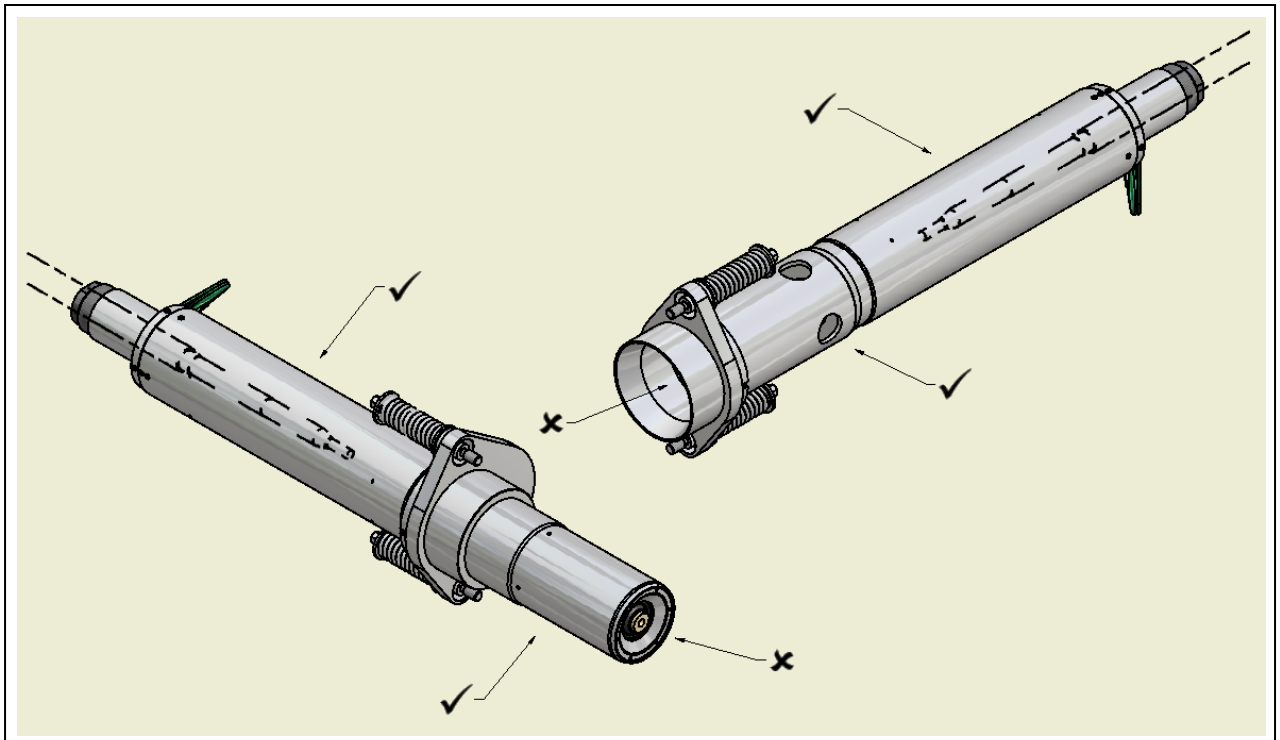

Figure 4A –Connector Power Washing precautions

6.4.5 Stab Plate Connectors

- **Compliance**

One half of a stab mate connector pair must be allowed to float so that misalignment tolerances can be accommodated.

- **Mate/De-Mate Speed**

The connectors have been designed to operate across a wide range of mate / de-mate speeds with POWER OFF. There is no practical limit to the speed at which the connectors may be mated or de-mated, however as a guide:

- a) Mating speed should not exceed 1 m/s.
- b) De-mating speed should not exceed 5 m/s

- **Pre-Mating Checks**

Before mating, the receptacle connector should be checked for debris. The connectors have been designed to accommodate sand and silt contamination, however large pieces of debris should be removed using a water jet.

- **Partial Disconnection**

Partial disconnection with the contact pin remaining between the primary and secondary diaphragms is not recommended. In this condition the level of insulation between the contact pin and socket contact is reduced and the connector is relying on the primary seals within the plug. There is also an increased risk of insulation break down at increased voltages.

- **Interrupted Connection**

Interrupted connection (i.e. Partial mate to full de-mate) can be carried out without any adverse affect to connectors, as long as the power is off.

- **Cathodic Protection:**

Stainless steel 316L (UNS S31603) connectors must be connected to the CP (Cathodic Protection) system at all times. Super Duplex stainless steel (UNS S32550) connectors should be isolated from the CP system to reduce the possibility of hydrogen embrittlement.

6.4.6 ROV Connectors

- **Alignment and Mating Technique**

These connectors have been designed to self align during mating. The connectors must be roughly aligned using the alignment marks on the connector body / alignment flange. The compliance within the connector handle, and the mating half, has sufficient compliance to accommodate fine adjustments during the final approach prior to connector engagement. The mating stroke should be as close as possible to one smooth movement, i.e. avoid 'pumping'.

- **Pre Mating Checks**

Before mating the receptacle connector should be checked for debris. The connectors have been designed to accommodate sand and silt contamination, however large pieces of debris should be removed using a water jet.

- **Mechanical Forces & Misalignment During Mating / De-Mating**

If mate / demate forces, maximum misalignment or overstroking forces have been defined, these will be specified in the product datasheet or design input document.

- **De-Mating**

De-mating is achieved by a straight pull on the ROV handle sufficient to release the latching mechanism.

- **Cathodic Protection**

ROV connectors are designed to operate isolated from the CP [Cathodic Protection] system. ROV connectors will not suffer damage by being connected to the CP system, however there will be a tendency for increased calcareous deposits on metal surfaces, and the possibility of hydrogen embrittlement.

- **Mating / De-Mating of ROV connectors by Diver**

Refer to INST-525 for procedure for diver mating of the ROV connectors.

- **Post-Mating checks**

Determining a correct mating of the connectors must be done by visual inspection only. A pull-check on the handle should never be made as this will release the latching mechanism causing the connectors to separate. When the connectors are fully mated the flanges of the two connectors should be abut, or with a small gap, **as shown in figure 5 below.**

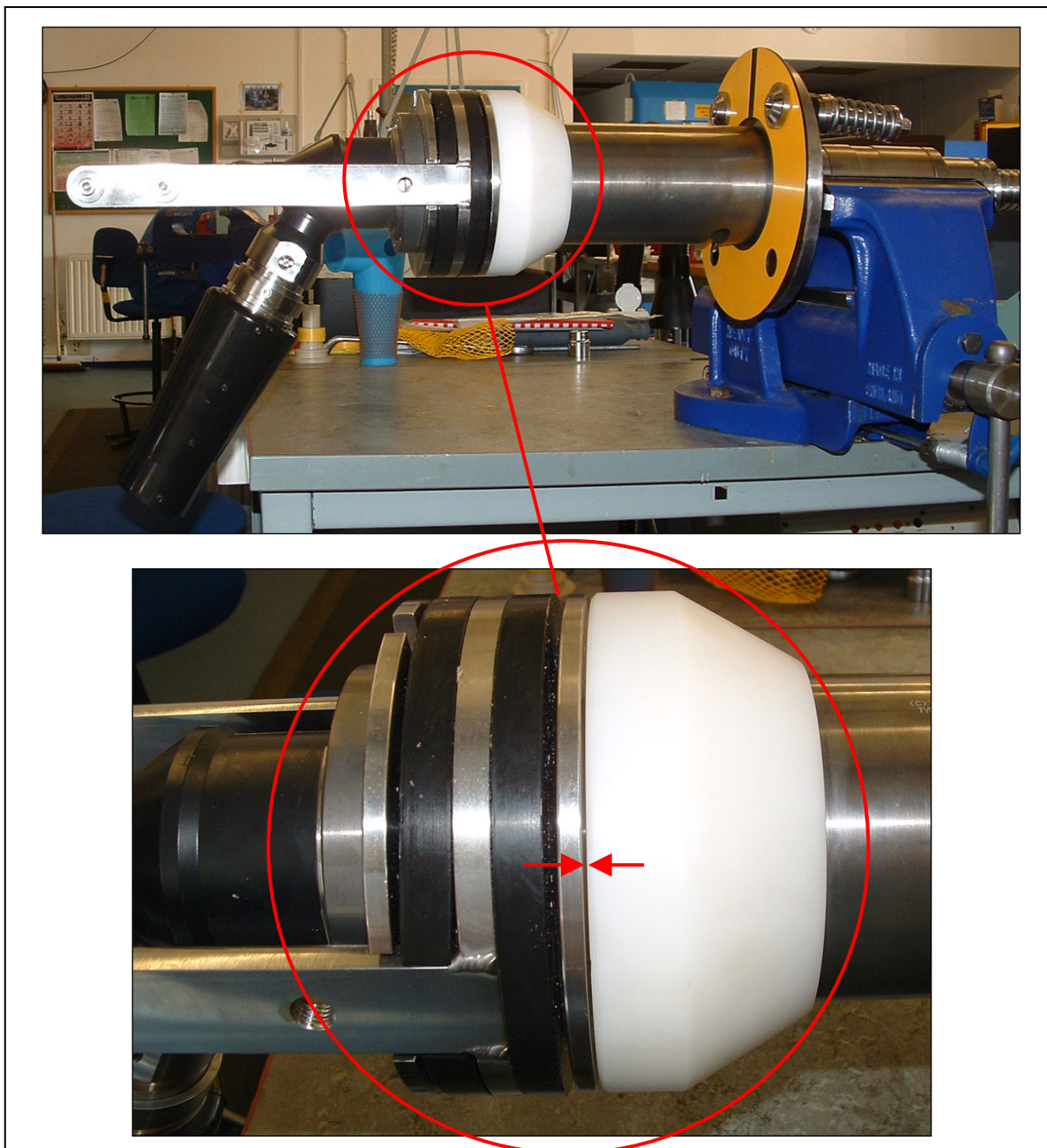

Figure 5 – Connectors Figure 5 - Connectors fully mate. Note small gap between flanges.

6.5 ELECTRON INSTRUMENTATION CONNECTORS



Figure 6 – Instrumentation Connector Pair

6.5.1 General

The ElecTRON range of Instrumentation connectors has been developed for long term reliable signal and low voltage control systems for down-hole applications in high pressure, high temperature environments.

The ElecTRON range of Instrumentation connectors consists of two unique types of connectors, wet mate & dry mate.

All connectors are usually supplied with protective caps. The protective caps must be removed prior to mating the connectors.

All mild steel sealing interfaces shall be inlaid with Inconel 625, or similar, where no additional protection (e.g. CP, Paint etc.) can be provided. This is to prevent localised pitting of the interface.

If the wet mate connectors are to be left unmated, in seawater, for any length of time dummy connectors must be used to protect the pin contacts in the receptacle connectors. Over exposure will increase the risk of corrosion damage or marine growth on the contact surfaces of the receptacle contact pins. This could lead to damage to the seals and insulation within the socket contacts. It is good practice to always fit the protective cap when a connector is unmated topside prior to deployment to provide mechanical protection.

If the dry mate connectors are to be left unmated for any length of time then protective caps must be used to protect the pin contacts in the receptacle connectors and the socket contact in the plug connectors. Ensure that all sealing elements of the dry mate connectors are clean and free from contamination prior to mating.

NOTE: 28 DAYS IS THE MAXIMUM CUMMULATIVE ALLOWABLE EXPOSURE OF UNPROTECTED CONTACT PINS TO SEAWATER OVER THE LIFE OF THE CONNECTOR. THIS ONLY APPLIES WITH POWER OFF.

The appropriate test connector must always be used to make electrical contact during testing. **UNDER NO CIRCUMSTANCES** should a foreign object (such as a screwdriver, test probe, or crocodile clip) be used as a test connection as this could damage the seals and insulation. Such actions will invalidate the warranty of the connector.

Guide pins (where applicable) must never be removed from test connectors as this can lead to damage and will invalidate the connector warranty.

NOTE: UNDER NO CIRCUMSTANCES MUST CONNECTORS BE DEMATED WHILST LIVE. NEITHER SHOULD CONNECTORS BE PARTIALLY MATED AND POWER APPLIED.

Refer to project specific data sheets and scope of supply drawings for performance specifications and detailed deployment instructions.

NOTE: NO PART OF THE CONNECTORS SHOULD BE DISMANTLED PRIOR TO OR DURING DEPLOYMENT, APART FROM THE REMOVAL OF PROTECTIVE CAPS, SINCE THERE ARE NO USER SERVICEABLE PARTS INSIDE.

Instrumentation connectors must be terminated by Siemens Subsea trained personnel only.

6.5.2 Protection of Receptacle Contact Pins

Under no circumstances must the contact pins in the receptacle connector be exposed to seawater with power on. If this situation does occur the contact surfaces of the pins will very rapidly degrade by electrolytic action. If these damaged pins are subsequently mated into a socket insert there is a **very high risk** of damage to the insulation and seals within the plug connector.

6.5.3 Removal of Marine Growth and Calcareous Deposits

To remove calcite growth from Siemens Subsea connectors, a solution of 50% Citric Acid is recommended. All Seawater exposed elastomeric materials in Siemens Subsea connectors have been fully tested against 50% Citric Acid and are compatible for a duration of 1 hour. In addition, the thermoplastic materials have good resistance to Citric Acid.

Other acid cleaners, such as 50% Acetic Acid, should not be used as they may cause deterioration of the elastomeric materials.

Chiselling and abrasive methods are not recommended. Use of a water jet is acceptable, but the jet should not be directed onto the shuttle pins at the front of the plug as this could result in a risk of water being forced through the primary seals.

6.5.4 Stab Plate Connectors

- **Compliance**

One half of a stab mate connector pair must be allowed to float, where possible, so that misalignment tolerances can be accommodated.

- **Mate/De-Mate Speed**

The connectors have been designed to operate across a wide range of mate / de-mate speeds with **POWER OFF**. There is no practical limit to the speed at which the connectors maybe mated or de-mated, however as a guide:

- a) Mating speed should not exceed 1 m/s.
- b) De-mating speed should not exceed 5 m/s.

- **Pre-Mating Checks**

Before mating, the receptacle connector should be checked for debris. The connectors have been designed to accommodate sand and silt contamination, however large pieces of debris should be removed using a water jet.

- **Partial Disconnection**

Partial disconnection with the contact pin remaining between the primary and secondary diaphragms is not recommended. In this condition the level of insulation between the contact pin and socket contact is reduced and the connector is relying on the primary seals within the plug. There is also an increased risk of insulation break down at increased voltages.

- **Interrupted Connection**

Interrupted connection (i.e. Partial mate to full de-mate) can be carried out without any adverse affect to connectors, as long as the power is off.

- **Cathodic Protection**

Stainless steel 316L (UNS S31603) instrumentation connectors must be connected to the CP [Cathodic Protection] system at all times. Super Duplex stainless steel (UNS S32550) connectors and nickel-chromium-molybdenum alloys should be isolated from the CP system to reduce the possibility of hydrogen embrittlement.

6.6 AQUATRON OIL TUBE HARNESSES



Figure 7: AquaTRON Oil Tube Harness

- Design life : 25 years
- External pressure : 0 to 300 bar (depth pressure)
- Recommended fill pressure : 10 bar
- Deployment rate : 10 metres / minute
- Operational temperature range: -5°C to +55°C
- Hose Burst Strength: 90 Bar
- Max twisting of AquaTRON Hose: 180° per 5m length
- Recommend hose be protected with tarpaulin sheet or equivalent if in direct sunlight.

Axial loads for Cable and AquaTRON oil tube

- Axial loads through glanded connectors should be kept to a minimum. The maximum applied loads will depend on the cable build.
- AquaTRON hose can withstand an axial load of 5000N. It has been tested to failure at 11000N.
- If cable ties are used leave loose on the hose. Do not compress.

Chemical Compatibility for AquaTRON oil tube

- For chemical compatibility use with AquaTRON oil tube see qualification report TR-422 section 3.11 and ERP-001-06.

6.7 CABLE HARNESSES / GLANDED CONNECTORS

- Axial loads on Glanded Connectors should be kept to a minimum unless the connector has been specifically designed to take such a load. (Contact Siemens Subsea Technical Department for advice).
- The maximum applied loads a glanded connector can take will depend on the cable build and the gland design.

6.8 ELECTRO OPTIC (FOETRON) CONNECTORS

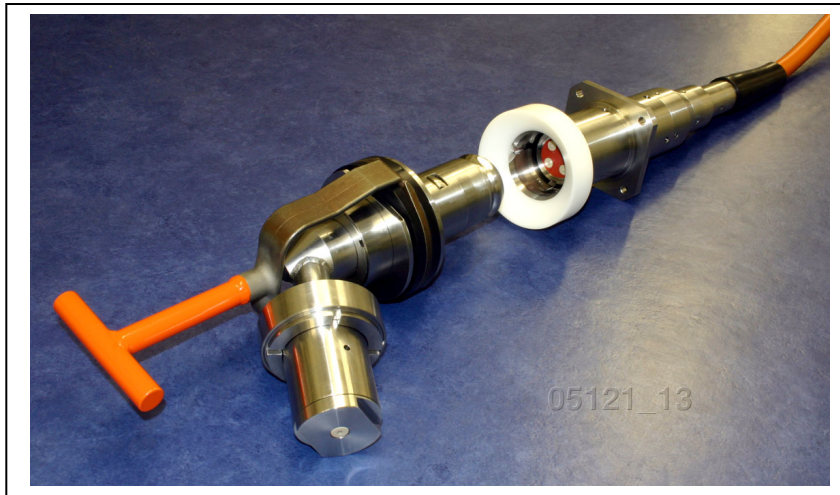

Figure 8 – Foetron Connector pair

6.8.1 General

The Foetron range of connectors have been developed for long term reliable signal and low power control system applications associated with offshore installations. The underwater mateable capacity of these connectors is achieved using pressure compensated inserts employing the CE principle.

Connectors are supplied with protective caps. The protective caps must be removed prior to mating the connectors. Any connectors or penetrators that include pigtails or exposed fibre lengths suitable for mounting onto an enclosure will be supplied with the fibres coiled and stored in a protective housing. The protective housing must be removed before the connector/penetrator is mounted to the enclosure and great care must be taken to ensure that damage does not occur to the optical fibres during removal of the housing or subsequent handling of the product.

All mild steel sealing interfaces shall be inlaid with Inconel 625, or similar, where no additional protection (e.g. CP, Paint etc.) can be provided. This is to prevent localised pitting of the interface.

If the connectors are to be left unmated, in seawater, for any length of time it is recommended that a subsea removable protective cap is used to protect both halves of the connector pair from debris or marine growth.

It is good practice to always fit the protective cap when a connector is unmated topside prior to deployment to provide mechanical protection.

The appropriate test connector must always be used to make electrical contact during testing. **UNDER NO CIRCUMSTANCES** should a foreign object (such as a screwdriver, test probe, or crocodile clip) be used as a test connection as this could damage the seals, fibre optic components and electrical insulation. Such actions will invalidate the warranty of the connector.

Test connectors should not be modified in any way as this can lead to damage and will invalidate the connector warranty.

NOTE: NO PART OF THE CONNECTORS SHOULD BE DISMANTLED PRIOR TO OR DURING DEPLOYMENT, APART FROM THE REMOVAL OF PROTECTIVE CAPS; THERE ARE NO USER SERVICEABLE PARTS INSIDE.

The FoeTRON range of connectors can be supplied either singularly or as part of a harness assembly. All FoeTRON connectors require the following tests during termination:

- Gas Leak
- Insulation Resistance
- High Voltage
- Continuity
- Optical Attenuation

Terminations to umbilical cables can be performed on-site or offshore by Siemens Subsea trained personnel where the cable cannot easily be moved or transported. Each FoeTRON connector is fitted with a pin or socket insert which has been hydrostatically tested and optically and electrically proven prior to despatch. Termination of these connectors should only be undertaken by Siemens Subsea trained personnel.

6.8.2 FoeTRON Electrical, Optical and Mechanical Specification

- Maximum current (dry & submerged) = 30A
- Maximum working voltage: 1000V rms
- Insertion loss @1310 & 1550nm : $\leq 0.5\text{dB}$ per connector pair or penetrator, 0.05dB per fusion splice.
- Return loss @ 1310 & 1550nm : $\leq -25\text{dB}$ per connector pair
- Rated number of operations: 100 mate / de-mate cycles (Power off)
- Working pressure: 5000 psi (9840 ft / 3000 metres water depth)
- Working temperature range: -5 to +60°C
- Storage temperature range: -40 to +70°C

6.8.3 Live Mate / Demate

The inserts used in the FoeTRON range of connectors are designed to be mated / demated with **POWER OFF**. If, **in exceptional circumstances**, it is necessary to mate / demate the connectors with power on, the following should be considered.

- **Resistive loads:**

Mating the connectors should not lead to any damage to the sealing mechanisms within the plugs or receptacles.

De-mating should be carried out quickly. The speed of de-mating should be above 0.5m/s to minimise the time an electrical arc can be established between the pin and socket contacts. Under no circumstances shall connectors be partially mated with power on.

- **Capacitive loads:**

Mating with power on will lead to an in-rush current. The magnitude of this in-rush current will depend on the capacitance of the circuit. It is very important that the in-rush current is no more than 500A.

- **Inductive loads:**

Mating the connectors should not lead to any damage to the sealing mechanisms within the inserts. De-mating must not be attempted as there is a risk of high back EMF's which will cause damage to the seals and insulation within the inserts.

- The maximum number of live mate/demate operations under the above conditions is **one** only.

6.8.4 Over Current Capacity

Over current capacity for all FoeTRON connectors is 100A for 5 seconds at no more than 2 per hour.

6.8.5 Removal of Marine Growth and Calcareous Deposits

To remove calcite growth from Siemens Subsea connectors, a solution of 50% Citric Acid is recommended. All Seawater exposed elastomeric materials in Siemens Subsea connectors have been fully tested against 50% Citric Acid and are compatible for a duration of 1 hour. In addition, the thermoplastic materials have good resistance to Citric Acid.

Other acid cleaners, such as 50% Acetic Acid, should not be used as they may cause deterioration of the elastomeric materials.

Chiselling and abrasive methods are not recommended. Use of a water jet is acceptable, but the jet should not be directed onto the shuttle pins at the front of the plug, or the pin contacts at the front of the receptacle, as this could result in a risk of water being forced through the primary seals.

6.8.6 Diver Mate Connectors

- **Alignment**

These connectors have been designed to self-align during mating. All that is required is to ensure that the alignment pin on the plug connector is engaged in the alignment groove within the receptacle connector before screwing the clamp ring up.

- **Pre Mating Check**

Before mating, the receptacle connector should be checked for debris. The connectors have been designed to accommodate sand and silt contamination, however large pieces of debris should be removed using a water jet.

- **Mating**

TBA

- **Post Mating Checks**

Full engagement of the connectors can be checked through the viewing hole in the clamp ring. If the connectors are fully mated then no gap should be visible between the plug and receptacle.

- **Cathodic Protection**

Stainless steel 316L (UNS S31603) diver mate connectors must be connected to the CP (Cathodic Protection) system at all times. Super Duplex stainless steel (UNS S32550) connectors should be isolated from the CP system to reduce the possibility of calcareous build-up and hydrogen embrittlement.

6.8.7 Stab Plate Connectors

- **Compliance**

One half of a stab mate connector pair must be allowed to float so that misalignment tolerances can be accommodated.

- **Mate/De-Mate Speed**

The connectors have been designed to operate across a wide range of mate / de-mate speeds with **POWER OFF**. There is no practical limit to the speed at which the connectors may be mated or de-mated, however as a guide:

- a) Mating speed should not exceed 1 m/s
- b) De-mating speed should not exceed 5 m/s

- **Pre-Mating Checks**

Before mating, the receptacle connector should be checked for debris. The connectors have been designed to accommodate sand and silt contamination, however large pieces of debris should be removed using a water jet.

- **Partial Disconnection**

Partial disconnection with the contact pin remaining between the primary and secondary diaphragms is not recommended, as there is a risk of damaging the insulation.

- **Interrupted Connection**

Interrupted connection (i.e. Partial mate to full de-mate) can be carried out without any adverse affect to connectors, as long as the power is off.

- **Cathodic Protection**

Stainless steel 316L (UNS S31603) stab plate connectors must be connected to the CP (Cathodic Protection) system at all times. Super Duplex stainless steel (UNS S32550) connectors should be isolated from the CP system to reduce the possibility of calcareous build up and hydrogen embrittlement.

6.8.8 ROV Connectors

- **Alignment**

These connectors have been designed to self align during mating. The connectors must be roughly aligned using the alignment marks on the plug body, flange and receptacle cone. The mounting of the ROV handle has sufficient compliance to accommodate fine adjustments during the final approach prior to connector engagement.

- **Pre Mating Checks**

Before mating the receptacle connector should be checked for debris. The connectors have been designed to accommodate sand and silt contamination, however large pieces of debris should be removed using a water jet.

- **Mechanical Forces During Mating / De-Mating**

The connectors have been designed to accommodate over stroking and bending forces to the following limits.

Over-stroking force < 2,205 lbf [9810N]

Bending < 370 ft-lbs. [500Nm]

Torsion < 370 ft-lbs. [500Nm]

- **Maximum Misalignment Values**

The values for maximum misalignment that the FoeTRON connectors can tolerate with mating still possible are as follows:

Misalignment Type	Amount
Rotational	±10°
Axial	±3 mm
Angular	±9.5°

- **Mating / de-mating forces (FoeTRON)**

Mating: <50 Kgf

De-mating: <50 Kgf

- **De-Mating**

De-mating is achieved by a straight pull on the ROV handle sufficient to release the latching mechanism.

- **Mechanical Over-Loading From The ROV**

The maximum bending moment that can be applied to the connectors when mated is 2000Nm before the risk of mechanical damage to the electrical connection becomes significant.

- **Cathodic Protection**

ROV connectors are designed to operate isolated from the CP [Cathodic Protection] system. ROV connectors will not suffer damage by being connected to the CP system; however there will be a tendency for increased calcareous deposits on metal surfaces, and the possibility of hydrogen embrittlement.

7. SIEMENS SUBSEA SENSOR DEPLOYMENT & MAINTENANCE

7.1 PACKING

For packing, Wooden Crates for up to 6 off or 3 off sensors shall be manufactured.

The design/production of the Wooden Crates shall be as shown in the sketch in section 6.8 below. The inside of the crates will be filled with preformed padding.

The packing design and procedure shall ensure that the equipment is lying stable during transportation.

7.2 UNPACKING

CAUTION:

THE SENSOR SHALL ONLY BE REMOVED FROM ITS PACKAGING BY PERSONNEL AUTHORISED BY THE CUSTOMER REFERRED TO IN THE PACKING LIST AND CONSIGNMENT NOTE!

- Ensure that the crates are positioned flat on the floor with the correct side uppermost.
- Open the hard case lid, remove the insulation/padding holding the sensors.
- Handle the sensors with care during operations.

7.3 STORAGE

- Equipment shall be stored in a dry area.
- Storage temperature: -20 to +60°C.
- The equipment should be stored in the hard case used for transportation.
- The equipment is to be stored away from any vibration sources.

7.4 CRITERIA FOR PRESERVATION

- The Crates shall be labelled as follows:

SIEMENS SUBSEA EQUIPMENT - HANDLE WITH CARE - MADE IN NORWAY

- The equipment shall not be stored in vibrating areas.
- Fork lift shall be used with care and only when strictly required.
- All shock loadings shall be avoided.

7.5 HANDLING

- The Sensors are measuring instruments using very sensitive sensor elements. The equipment shall therefore be handled with care and following precautions shall be taken when handling the equipment:
 - DO NOT DROP.
 - DO NOT expose the equipment to vibration and shock.
 - DO NOT expose the equipment to environment conditions beyond the storage specifications. ref. item 6 above, or the operational environment specification, (0-30°C) if operational.

7.6 SHIPPING AND MARKING

- The sensors transmitter shall be shipped in the Wooden crates described in section 6.8.
- All markings shall be legible, permanent and un-obscured.

7.7 STACK LIMITATION

- Crates with max. 6 off sensors: 2 CRATES MAX.
-
- Crates with max. 3 off sensors: 3 CRATES MAX.

7.8 TRANSPORTATION CRATE

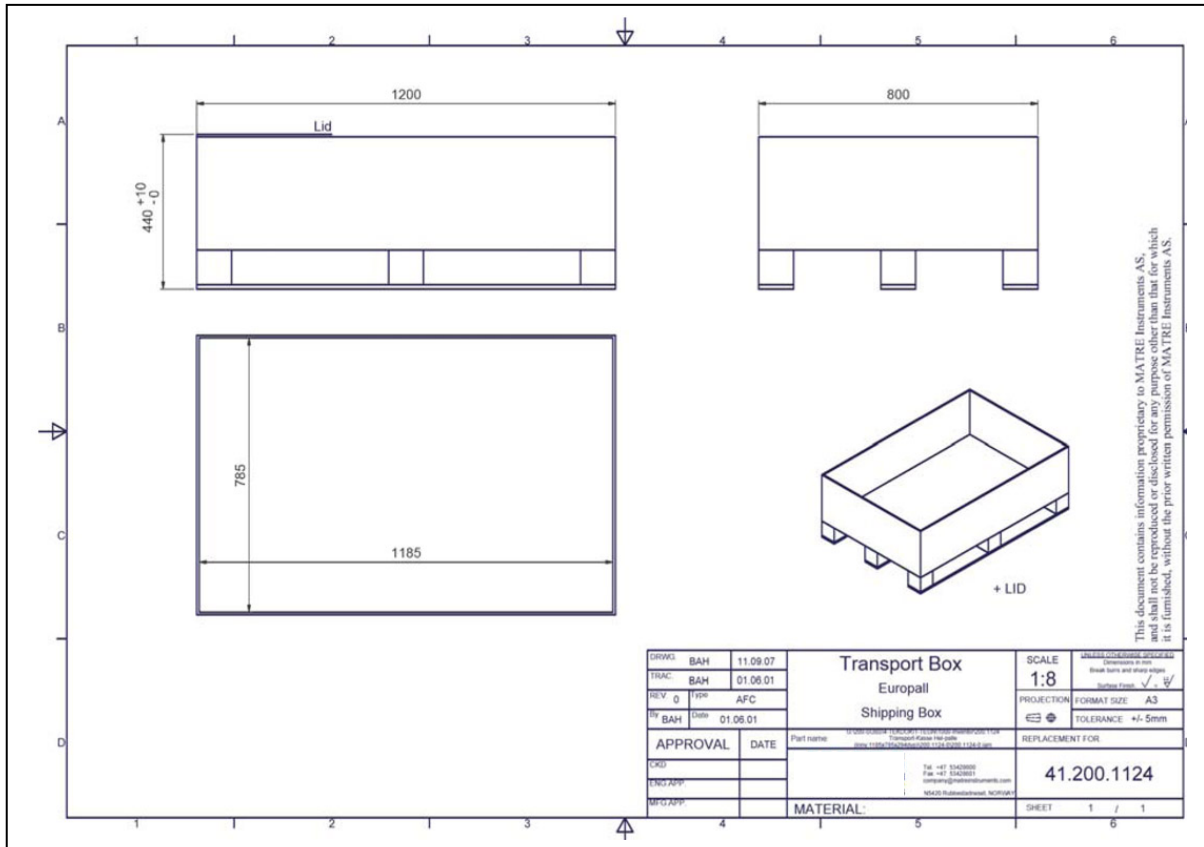

7.8.1 Crate for Maximum 6-off sensors



7.8.2 Typical packing of 6-off sensors within the Crate in 6.8.1

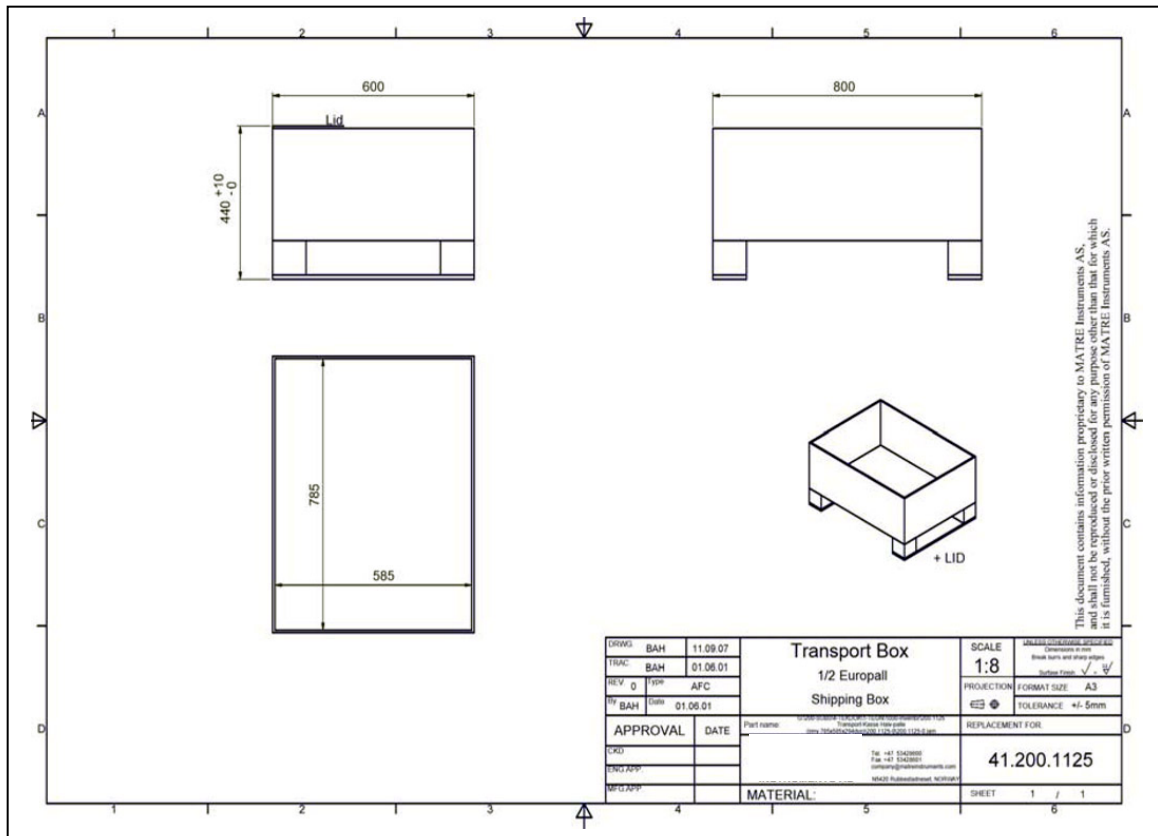

7.8.3 Crate for Maximum 3 off sensors



7.8.4 Typical packing of 3 off sensors within the Crate in 6.8.3

8. INFORMATION AND NOTES / HEALTH & SAFETY FEEDBACK

DATE	DESCRIPTION