



FIRE SAFETY APPLICATION CENTER

FDA241_FDA221

ASD Aspirating smoke detector

Siemens aspirating smoke detector (ASD) for standalone operation in industrial applications

- Patented technology
- Early detection of a wider spectrum of particle sizes in the air
- Configuration using the USB interface
- 'ASD Asyst-Tool' software to assist with pipe configuration
- Unique dust-resistant detection chamber
- Intuitive front indicator for airflow and smoke value
- Access to service functions
- Different event protocols
- Offline/online configuration supported
- Cleaning function (FDA241)

Fulfills following specific requirements:

- SIL2 approved acc. EN61508 standards
- Meets material requirements according EN45545-2
- Proved by notified body acc. EN50155



SIEMENS

Properties

- Extended optical detection thanks to dual wavelengths (blue and infrared): The aspirating smoke detectors FDA241 and FDA221 use dual-wavelength technology to trigger an alarm at the earliest possible moment. They are designed to protect small and medium-sized business-critical environments for monitoring areas of up to 800 m² (FDA241) or 500 m² (FDA221). The detectors continually suck in air through a pipe system via their aspirating holes. The air is fed into a uniquely designed detection chamber, in which tiny smoke particles are detected by scattered light.
- Lower mounting and service costs due to its easy accessibility design for very short installation and/or dismantling proceedings.
- Configuration by using the USB interface to upload the device configuration enables very short start-up sequences. All detector configurations, downloading event-log, maintenance work, and alarm and fault management processes can be carried out by USB interface or at a central location – the fire control panel. This ensures better control while also reducing the costs of the overall solution.
- 'Out-of-the-box' mounting and commissioning: Installation is simple thanks to combined functions for normalizing smoke values and airflow, as well as appropriate presettings for alarm and fault thresholds.
- ASD filter box FDAZ292 available as an accessory: Dust and other dirt is filtered out of the aspirated air and does not get into the aspirating smoke detector. The filters in the ASD filter box are easy to replace.
- Via relay outputs, fault and alarm conditions can be transmitted to the available control panel (stand-alone application).

Use

Aspirating smoke detectors are used for early detection of smoke-generating fires. They are especially suited to applications in which point detectors are pushed to their limits, cannot be used or can only be used with restrictions.

The aspirating smoke detector continually takes air from the monitored area using a connected pipe system with defined aspirating holes. The air is supplied to the detection chamber and is analyzed for smoke particles using the detector installed there. The sensitivity of the detector can be adjusted.

The position and size of the aspirating holes are calculated with the 'FXS2056 ASD Asyst Tool V2' software. The calculation ensures that the air passes from the aspirating hole to the detector in the time specified and with the required calculated sensitivity.



The 'FXS2056 ASD Asyst Tool V2' software is replacing the 'FXS2055 ASD Asyst Tool' software.

Examples of application

- Cavities such as false ceilings or false floors
- Clean rooms
- Rooms the height of which is greater than that permitted for point detectors
- Rooms with electromagnetic fields which influence the function of point detectors
- Large rooms up to 800 m²
- Separate monitoring of control cabinets and electronics cabinets
- Data centers
- Telecommunication centers
- Mounting lines
- Cable tunnels
- Conveyor belts

Applications with a filter box

- Areas with polluted air, in which the pollution has impaired the performance other detector technologies
- Subway application (stations, subway car)
- Passenger areas in rolling stocks
- Mounting lines
- Recycling facilities
- Cement factories
- Mining industry
- Agricultural operations
- All other applications with visible dust load

Functions

Indication

The display contains clear, comprehensible bar graphs for smoke and airflow, as well as an alarm indicator, an error indicator, and a dust indicator (FDA241).

When the housing cover is open, the operator has access to the 'Reset', 'Normalize Smoke', and 'Normalize Flow' functions, as well as the mini USB connector.

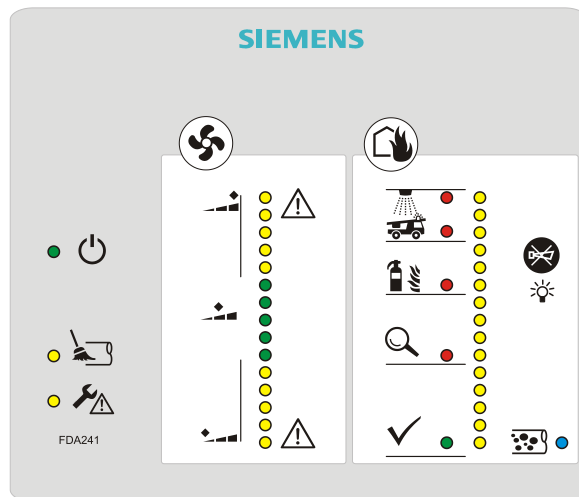



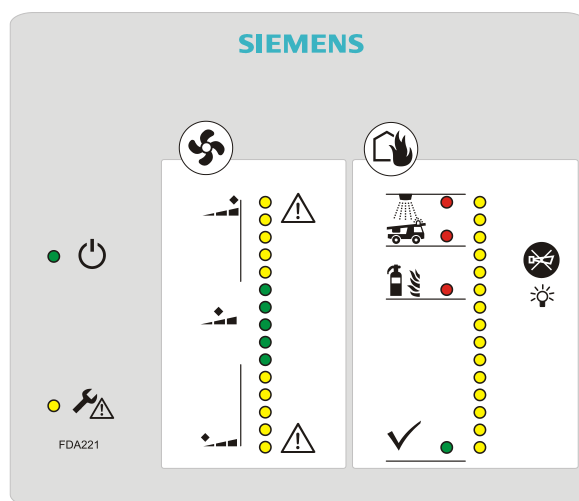









Front indicator FDA241





Front indicator FDA221

Legend for the response indicators

| | | | |
|---|--|--|--|
|  Operation |  Flow warnings |  Smoke alarm |  Info alarm |
|  Blowing out |  a } High flow Normal flow b } c } Low flow |  Fire 2 |  No smoke |
|  Error | |  Fire 1 |  Fault/test |
| | |  Pre-alarm |  Dust |

Opening the detector

| | |
|---|---|
|  |  CAUTION |
| | <p>Damage to the connection cable</p> <p>In order to prevent damage to the connection cable when positioning the housing cover, make sure that the connection cable has been routed correctly.</p> |

The service area for the detector can be accessed in two ways.

- Partial access:
 - Remove the two screws on the top of the detector.
 - Slide the housing cover up until you hear it snap into place.
- Full access:
 - Remove the two screws on the top of the detector.
 - Slide the housing cover up until you hear it snap into place.
 - Pull the housing cover out slightly at the sides and lift it up.
 - Remove the housing cover.

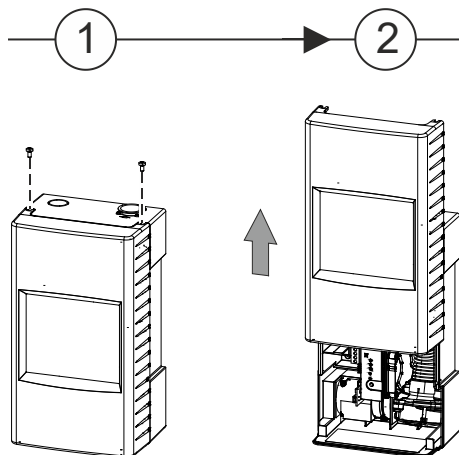

Service LED indicators and buttons

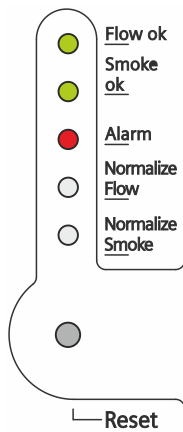

Flow OK

As soon as the selftest for normal operation has been completed successfully, the 'Flow OK' LED starts to flash.

Smoke OK

As soon as the selftest for normal operation has been completed successfully, the 'Smoke OK' LED starts to flash.

Alarm

In the event of a smoke alarm, the 'Alarm' LED starts to flash.

Normalization of the airflow

To determine the nominal airflow of the detector, perform this function during commissioning. The nominal value established during normalization of the airflow forms the setpoint value for monitoring the airflow during normal operation.

To perform this function, use a thin object (such as a paper clip or a watchmaker's screwdriver) to press the button in the opening.

Once you have finished with this function, press the button in the opening again.

The smoke detector uses standard values for monitoring during normalization.

Normalization of the smoke density

To determine the nominal air quality in relation to the smoke density, perform this function during commissioning. The nominal value established during normalization forms the setpoint value for monitoring the smoke density during normal operation.

To perform this function, use a thin object (such as a paper clip or a watchmaker's screwdriver) to press the button in the opening.

Once you have finished with this function, press the button in the opening again.

The smoke detector uses standard values for monitoring during normalization.



The detector provides information about the current normalization process via LED flashing sequence (no distinction is made between smoke and airflow).

Reset button

Use the reset button to reset all of the detector's status indicators. These indicators can refer to fire alarms or airflow events. Resetting the fire alarm also resets the associated relay.

USB connection

You can use a mini USB cable to connect the detector to a Windows PC. To set up the detector, use the configuration tool 'FXS2051 ASD Configuration Tool'.

Test function LED

Hold the 'Buzzer silence' button down for 5 seconds. The LEDs on the display are tested with 3 different brightness settings.

FDAZ292 ASD filter box

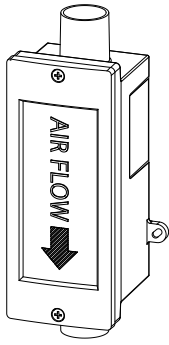

- Filter box for installation in the pipe system for aspirating smoke detectors
- Filters dust and other dirt out of the air aspirated by the aspirating smoke detector
- Minimizes internal contamination of the aspirating smoke detector
- Contains filter set FDAZ292-AA with three filters, coarse/medium/fine
- Compatible with the aspirating smoke detectors FDA241 and FDA221
- You will find more information in document A6V10877841

FDAZ292-AA ASD filter set

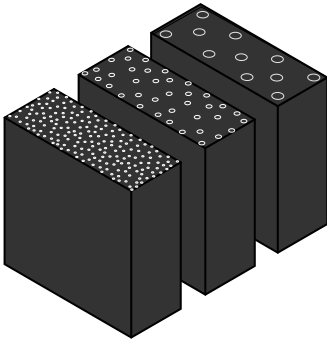

- Spare part for the ASD filter box FDAZ292
- Filter set contains one coarse filter, one medium filter, and one fine filter

FDAZ291 aspirator (FDA241/FDA221)

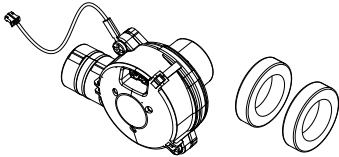

- Spare part for the aspirating smoke detectors FDA241 and FDA221
- You will find more information in document A6V10916366

Type Overview

| Type | Designation | Order number | Weight [kg] |
|--------------------|---------------------------|---------------|-------------|
| FDA241 | Aspirating smoke detector | FSAC request | 1.495 |
| FDA221 | Aspirating smoke detector | FSAC request | 1.495 |
| Accessories | | | |
| FDAZ292 | ASD filter box | S54333-C92-A1 | 0.220 |
| Spare parts | | | |
| FDAZ292-AA | ASD filter set | S54333-S91-A1 | 0.009 |
| FDAZ291 | Aspirator (FDA241/FDA221) | S54333-G1-A1 | 0.106 |

Related documents such as environmental declarations, CE declarations, etc., can be downloaded at the following Internet address:

<http://siemens.com/bt/download>

Notes

Disposal



The device is considered an electronic device for disposal in accordance with the European Guidelines and may not be disposed of as domestic garbage.

- Dispose of the device through channels provided for this purpose.
- Comply with all local and currently applicable laws and regulations.

Technical data

| | FDA241 | FDA221 |
|--|---|--------|
| Operating voltage | DC 19...30 V | |
| Operating current at DC 24 V | 150 mA (nominal), 250 mA (during alarm) | |
| Dimensions (W x H x D) | 162 x 285 x 120 mm | |
| Protection category | IP30 | |
| Installation position | Vertically upward, vertically downward | |
| Sound power level LWA [dBA]: ¹⁾ | - | |
| At suction speed | | |
| - High | 37 | 33 |
| - Medium | 33 | 30 |
| - Low | 30 | 26 |
| Operating temperature | -20...+60 °C | |
| specific approval | Temperature class OT4: -40...+70 °C | |
| Air humidity | 5...95 % (no moisture condensation) | |
| Dust indicator | Yes | - |
| Maximum pipe length | | |
| - Single line | 60 m | 30 m |

| | FDA241 | FDA221 |
|---|--|------------------------------|
| - Branched lines | 2x 60 m | 2x 25 m |
| Options for aspirating holes | Prefabricated option or the maximum pipe length must correspond to the calculation made using the 'FXS2056 ASD Asyst Tool V2' software | |
| Air intake/exhaust pipe | Metric: 25 mm outer diameter (OD) | |
| Monitoring area (dependent on local provisions and standards) | Up to 800 m ² | Up to 500 m ² |
| Relay alarm outputs Can be selected with/without lock Nominal current 2.0 A at DC 30 V. Contact: NO/NC | 4 | 3 |
| Fault relay | 1 | 1 |
| Cable inlet | 10 cm x 2.5 cm on the rear or from above | |
| Terminal configuration | Screw terminals | |
| Cable cross section | 0.2...2.5 mm ² (AWG 12...30) | |
| Other interfaces | Power supply, 4...20 mA | |
| Alarm threshold for parameter sets: | | |
| Fire 1 | 10 sets 0.05...2.0 %/m obs | 5 sets 0.20...2.0 %/m obs |
| Fire 2 | 10 sets 2.0...20 %/m obs | 5 sets 6.0...20 %/m obs |
| Alarm delay, can be set individually | 0...300 seconds: default value 0 seconds smoke density and 15 seconds flow | |

| | FDA241 | FDA221 |
|--|--|--------|
| Indication | <ul style="list-style-type: none"> • 4x alarm status indicators (FDA241) • 3x alarm status indicators (FDA221) • Faults • Blowing out (FDA241) • Dust (FDA241) • Smoke density and flow indicator | |
| Service area | <ul style="list-style-type: none"> • LED 'Status OK' • USB • Settings for reset functions • Settings for smoke density and airflow | |
| Event log | Non-volatile event memory with time and date stamp for: smoke density, airflow, detector status, and faults | |
| Normalization of smoke value and airflow | <ul style="list-style-type: none"> • Setting of threshold values for smoke alarms and faults • User setting for normalization of smoke density and airflow • Preset values are retained during the normalization period | |
| Warranty period | 2 years | |
| Approvals <ul style="list-style-type: none"> • VdS • Standards • TUEV | <p style="text-align: center;">FDA241 / FDA221 G213050</p> <p style="text-align: center;">EN 50155, EN 50121-3-2, EN 61000-4-2/3/4/5/6, EN 60068-2-1/2/27/30, EN 61373, EN 45545-2</p> <p style="text-align: center;">Test Report TÜV Austria EN50155 Prüfbericht TÜV Austria EN50121-3-2, EN50155 EMV Prüfbericht AIT EN60068-2-27, EN61373 Schocktest Prüfbefund TÜV Austria ÖNORM EN 60068-2-1 SIL Report & Certificate acc. EN61508</p> | |

¹ A-weighted sound power level in [dB] as per DIN EN ISO 3744-2009, measured with a pipe piece at the air inlet and at the air outlet

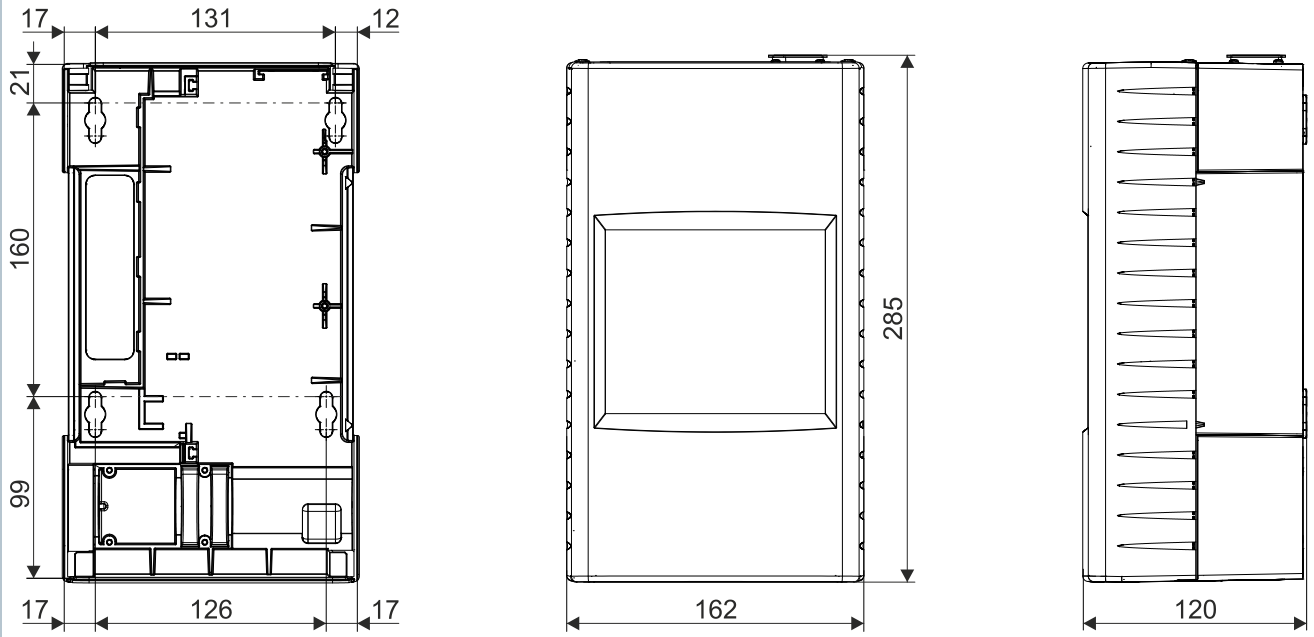

Dimensional drawings

FDA241, FDA221

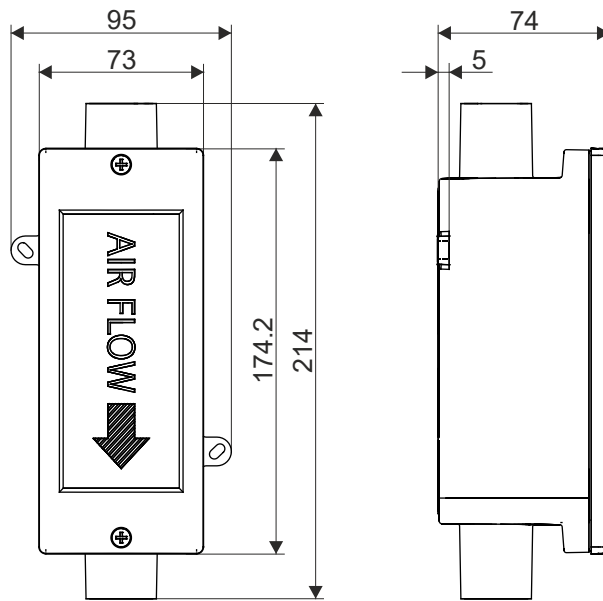

FDAZ292



| | | |
|--|-------------------------------|--|
| <p>13  0786</p> | <p>FDA221 / FDA241</p> | <p>Siemens Schweiz AG; Theilerstrasse 1a CH-6300 Zug Technical data: see doc. A6V10334410</p> |
| <p>FDA221 / FDA241 - Aspirating smoke detector for use in fire detection and fire alarm systems installed in buildings.</p> | | |
| <p>305/2011/EU (CPR): EN 54-20 / EN 54-17 ; 2014/30/EU (EMC): EN 50130-4 / EN 61000-6-3 ; 2011/65/EU (RoHS): EN 50581</p> | | |
| <p>The declared performance and conformity can be seen in the Declaration of Performance (DoP) and the EU Declaration of Conformity (DoC), which is obtainable via the Customer Support center: Tel. +49 89 9221-8000 or http://siemens.com/bt/download</p> | | |
| <p>DoP No.: 0786-CPR-21270; DoC No.: CED-FDA221/FDA241</p> | | |
| <p>13  0786</p> | <p>FDCC221S</p> | <p>Siemens Schweiz AG, Theilerstrasse 1a CH-6300 Zug Technical data: see doc. A6V10334410</p> |
| <p>FDCC221S - Input/output device incl. short-circuit isolator for use in fire detection and fire alarm systems installed in buildings.</p> | | |
| <p>305/2011/EU (CPR): EN 54-17 / EN 54-18 ; 2014/30/EU (EMC): EN 50130-4 / EN 61000-6-3 ; 2011/65/EU (RoHS): EN 50581</p> | | |
| <p>The declared performance and conformity can be seen in the Declaration of Performance (DoP) and the EC Declaration of Conformity (DoC), which is obtainable via the Customer Support center: Tel. +49 89 9221-8000 or https://siemens.com/bt/download</p> | | |
| <p>DoP No.: 0786-CPR-21270; DoC No.: CED-FDA221/FDA241</p> | | |



Product documentation (standardized documents)

| Document ID | Title |
|---------------------------------------|------------------|
| FSAC_TM_ASD_FDA2x1 | Technical manual |
| FSAC_Planning_Mounting_ASD_FDA2x1 | User Manual |
| FSAC_Mounting_Installation_ASD_FDA2x1 | User Manual |

Issued by
Fire Safety Application Center Austria

Siemens AG Österreich
Smart Infrastructure
RC-AT SI BP FSAC
Siemensstraße 90
AT-1210 Wien
Tel. +43 51707-0
www.siemens.com

© Siemens Aktiengesellschaft Österreich, 2024
Technical specifications and availability subject to change without notice.