

SIEMENS



Catalog
D 37.1

Edition
August
2023















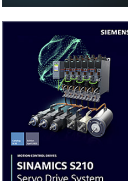

MOTION CONTROL DRIVES

SINAMICS S200

Servo drive system

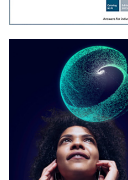
[siemens.com/d37-1](https://www.siemens.com/d37-1)

Related catalogs

<p>Motion Control Drives D 31.1 SINAMICS Inverters for Single-Axis Drives Built-In Units</p> <p>PDF (E86060-K5531-A111-A4-7600)</p>		<p>Motion Control System PM 21 SIMOTION Equipment for Production Machines</p> <p>E86060-K4921-A101-A4-7600</p>	
<p>Motion Control Drives D 31.2 SINAMICS Converters for Single-Axis Drives Distributed Converters</p> <p>PDF (E86060-K5531-A121-A3-7600)</p>		<p>Industrial Controls IC 10 SIRIUS</p> <p>PDF (E86060-K1010-A101-B5-7600)</p>	
<p>Motion Control Drives D 31.5 SINAMICS Converters for Single-Axis Drives SINAMICS G120X infrastructure converters for HVAC/Water/Wastewater</p> <p>PDF (E86060-K5531-A151-A4-7600)</p>		<p>Low-Voltage Power Distribution and Electrical Installation Technology LV 10 SENTRON • SIVACON • ALPHA</p> <p>PDF (E86060-K8280-A101-B6-7600)</p>	
<p>Motion Control Drives D 32 SINAMICS S210 Servo Drive System</p> <p>PDF (E86060-K5532-A101-A8-7600)</p>		<p>SIMATIC ST 70 Products for Totally Integrated Automation</p> <p>PDF (E86060-K4670-A101-C0-7600)</p>	
<p>Motion Control Drives D 33 SINAMICS V90 Basic Servo Drive System</p> <p>E86060-K5533-A101-A2-7600</p>		<p>SSIMATIC HMI / PC-based Automation ST 80/ST PC Human Machine Interface Systems PC-based Automation</p> <p>PDF (E86060-K4680-A101-D1-7600)</p>	
<p>Motion Control Drives D 34 SIMATIC MICRO-DRIVE Servo Drive System</p> <p>PDF (E86060-K5534-A101-A2-7600)</p>		<p>Industrial Communication IK PI SIMATIC NET</p> <p>E86060-K6710-A101-B8-7600</p>	
<p>SINAMICS S120 D 21.3 Chassis Format Converter Units Chassis-2 Format Converter Units Cabinet Modules, Cabinet Modules-2</p> <p>SINAMICS S150 Converter Cabinet Units PDF (E86060-K5521-A131-A8-7600)</p>		<p>SITRAIN Digital Industry Academy</p> <p>www.siemens.com/sitrain</p>	
<p>Motion Control Drives D 21.4 SINAMICS S120 and SIMOTICS</p> <p>E86060-K5521-A141-A1-7600</p>		<p>SiePortal Information and Ordering Platform on the Internet:</p> <p>sieportal.siemens.com</p>	
<p>SIMOTICS S-1FG1 D 41 Servo geared motors Helical, Parallel shaft, Bevel and Helical worm geared motors</p> <p>PDF (E86060-K5541-A101-A6-7600)</p>			



Combining the real and digital worlds ...
Transformation

Catalog
D 37.1

Edition
August
2023

MOTION CONTROL DRIVES

SINAMICS S200 Servo drive system

[siemens.com/d37-1](https://www.siemens.com/d37-1)

Dear Customer,

We are pleased to present you with the new Catalog D 37.1 · August 2023. The catalog provides a comprehensive overview of the SINAMICS S200 servo drive system consisting of a SINAMICS S200 servo drive, a SIMOTICS S-1FL2 servomotor and a matching MOTION-CONNECT connection system.

The products listed in this catalog are also included in SiePortal. Please contact your local Siemens office for additional information.

Up-to-date information about SINAMICS S200 is available online at
www.siemens.com/sinamics-s200

You can access SiePortal online at
<https://sieportal.siemens.com>

Your personal contact is keen to receive your suggestions and recommendations for improvement. You can find your contact in our contact database at
www.siemens.com/automation-contact

We hope that you will often enjoy using Catalog D 37.1 · August 2023 as a selection and ordering reference document and wish you every success with our products and solutions.

With kind regards,

A handwritten signature in blue ink, appearing to read 'Frank Golüke', is positioned below the text 'With kind regards,'.

Frank Golüke
Vice President
General Motion Control
Siemens AG, Digital Industries, Motion Control

SINAMICS S200 Servo drive system

Motion Control Drives



Catalog D 37.1 · August 2023

Refer to SiePortal for current updates of this catalog:
<https://sieportal.siemens.com>

Please contact your local Siemens branch.

© Siemens 2023

Click on an Article No. in the catalog PDF to call it up in SiePortal and to obtain all the information.

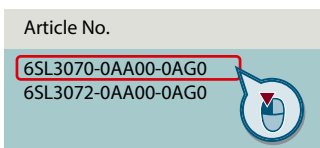

Or directly on the internet, e.g.
www.siemens.com/product_catalog_DIMC?6SL3070-0AA00-0AG0



The products and systems described in this catalog are manufactured/distributed under application of a certified quality management system in accordance with EN ISO 9001. The certificate is recognized by all IQNet countries.

System overview

1

SINAMICS S200 servo converters

2

SIMOTICS S-1FL2 servomotors

3

MOTION-CONNECT connection systems

4

Engineering tools

5

Services and documentation

6

Appendix

7

Digitalization in drive technology

From the digital world to the real world

[siemens.com/digital-drives](https://www.siemens.com/digital-drives)

Increase your transparency and productivity by digitalizing your drive technology

Many drives are used in the manufacturing and process industries. They produce lots of data anyway – why not use them to increase the availability and productivity of machines and plants?

Drive technology offers the ideal entry point into the world of digitalization – for plant and machine builders as well as for users.

The digitalization portfolio for the drive train spans over the complete life cycle – from the design phase to realization and optimization – in the digital and the real world.

Our portfolio contains drive simulation solutions and efficient engineering tools, comprehensive connectivity that allows drives to be easily linked to the relevant platforms as well as smart analytics (e.g. cloud and edge apps) and drive system services.

These solutions enable you to gain a better understanding of processes, states and utilization. The health status of the drive train can be monitored and analyzing drive data enables an early detection of anomalies and reduces downtimes. This way, availability and productivity of machines and plants can be increased and the actual maintenance demand can be identified. Furthermore, data-based business models and service offerings are facilitated.

Our digitalization portfolio covers all phases of the life cycle: from the design phase to realization and optimization. It covers the digital and the real drive train.



Design: By creating a digital twin of the drives, machine builders can shorten their time-to-market since they can design, simulate and optimize their machine before ordering any material or products. Together with other tools from the engineering box, simulation can also speed up the engineering phase of drives and entire machines, for example by virtual commissioning of the PLC.

Realize: Once the machine is in operation, the drives can be connected to other platforms, for example to the cloud and Industrial Edge. This creates transparency in terms of what is going on inside the drive train, e.g. with regard to the actual current, torque and speed.

Optimize: To understand the collected data, our drive train analytics portfolio provides algorithms and analysis tools to unlock the potential of the data and turn the gained transparency into insights and valuable knowledge. These insights can then again be used in the design phase of the next life cycle, thus closing the loop.



Benefits of drive train digitalization

Machine builders



Availability



Increase the availability of your machines

Speed



Shorten time-to-market

Business models



Develop new service and business models

Machine operators



Productivity



Increase the productivity of your production

Flexibility



Increase the flexibility of your production

Efficiency



Identify potential for optimization

Benefits for machine and plant builders

- Increased availability of machines and plants – thanks to digital options for checking and implementing design improvements and comprehensive monitoring of drive systems
- Shorter time-to-market and faster development times – thanks to practical software tools and a continuous database for concurrent development processes as well as virtual simulations, tests, and commissioning of machines and plants
- New options for future service and business models – ranging from customized application solutions and digital services to contractually guaranteed availabilities of machines and plants

Benefits for machine and plant operators

- Increased availability and productivity of production, fewer unscheduled downtimes – through the early detection of deviations and emerging risks thanks to digital drive monitoring
- More flexible production down to batch size 1 – through more effective use of knowledge from existing production lines thanks to transparent utilization, states, locations, and capacities down to the drive level
- Identification of potential for optimization to make production faster, better, and more efficient thanks to data-based transparency – for example, for faster modifications, simpler quality control, and the early prediction of maintenance demand as well as demand-oriented maintenance



TIA Selection Tool – quick, easy, smart configuration

For you to get the most out of our portfolio quickly and easily.

Do you always need the optimum configuration for planning your project?

For your application we offer the TIA Selection Tool to support all project planners, beginners and experts alike.

No detailed portfolio knowledge is necessary.

TIA Selection Tool is available for download as a free desktop version or a cloud variant.

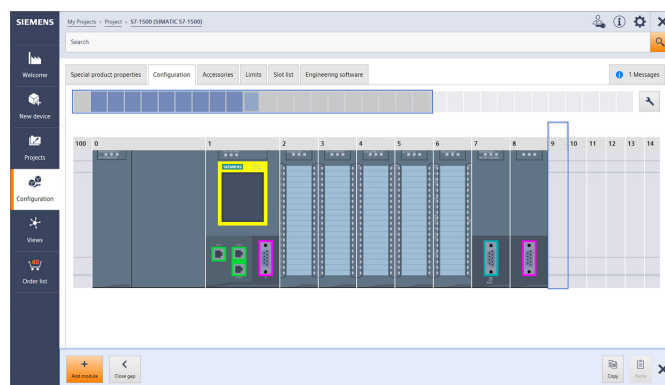

Your Advantages

Quick

- Configure a complete project with just a few entries – without a manual, without special knowledge
- Import and export of hardware configuration to TIA Portal or other systems
- Ideal visualization of the projects to be configured

Easy

- Tool download either as desktop version or web-based cloud version
- Technically always up-to-date about product portfolio and innovative approaches
- Highly flexible, secure, cross-team work in the cloud
- Direct ordering in SiePortal

Smart

- Smart selection wizard for error-free configuration and ordering
- Configuration options can be tested and simulated in advance
- Library for archiving sample configurations

The TIA Selection Tool is a completely paperless solution.

Download it now:

www.siemens.com/tst

For more
information,
scan the
QR code



System overview



1/2	The SINAMICS converter family
1/2	Overview
1/6	Drive selection
1/6	Overview
1/6	More information
1/7	SINAMICS S200 servo drive system
1/7	Overview
1/7	Benefits
1/8	Application
1/9	Design
1/11	Integration
1/12	Configuration
1/13	Technical specifications
1/14	Selection and ordering data
1/14	SINAMICS S200 servo drive system with SIMOTICS S-1FL2
1/14	- Low Inertia servomotors
1/20	- Medium Inertia servomotors
1/26	- High Inertia servomotors
1/32	Accessories
1/32	More information
1/33	SINAMICS S200 starter kit
1/33	Selection and ordering data
1/34	Recommended SIMATIC S7 controller
1/34	Selection and ordering data

System overview

The SINAMICS converter family

Overview

Integration in automation

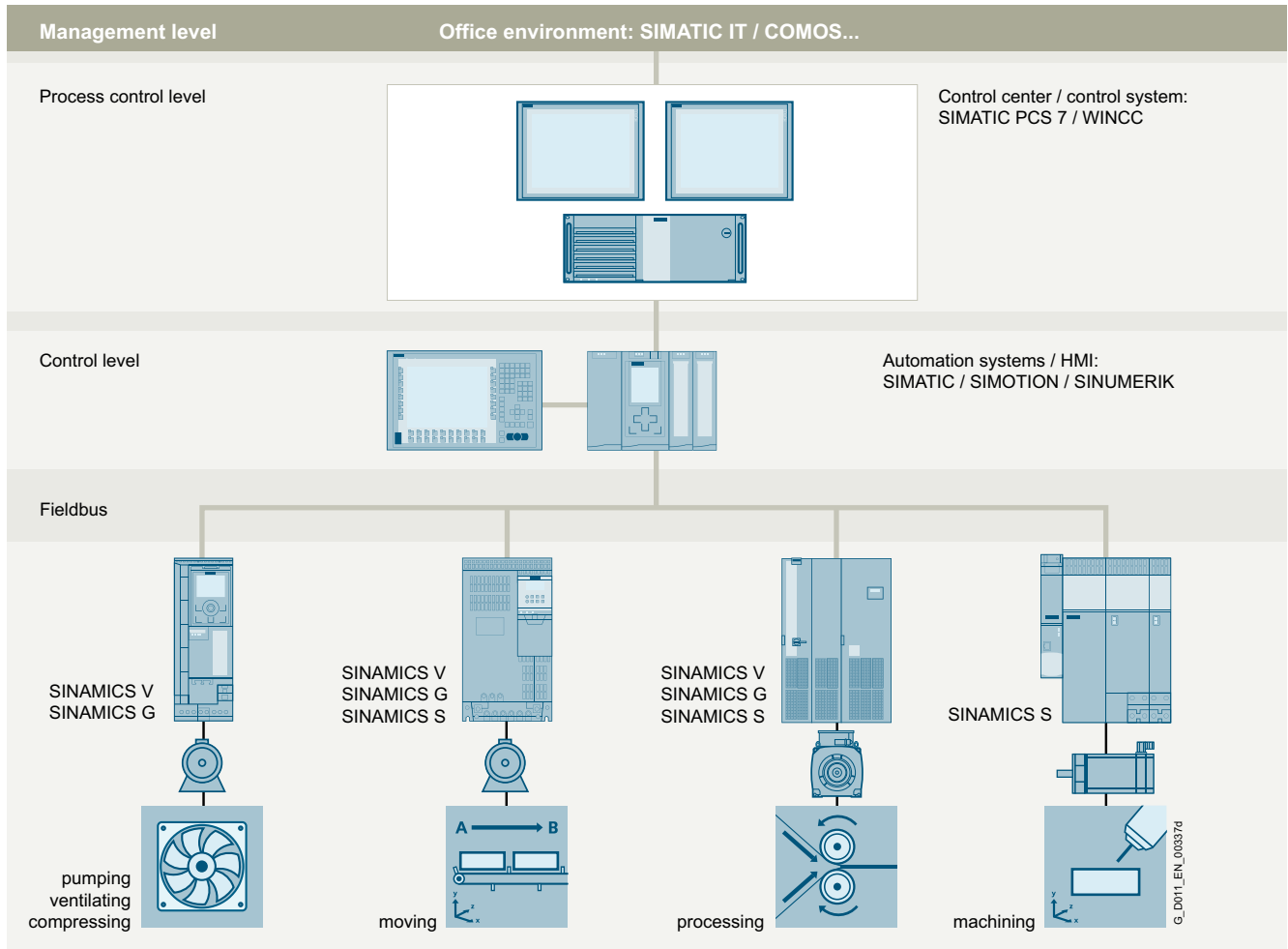

Totally Integrated Automation and communication

SINAMICS is an integral component of the Siemens "Totally Integrated Automation" concept. Integrated SINAMICS systems covering configuration, data storage, and communication at automation level ensure low-maintenance solutions with the SIMATIC, SIMOTION and SINUMERIK control systems.

Depending on the application, the appropriate variable frequency drives can be selected and incorporated in the automation concept. With this in mind, the drives are clearly subdivided into their different applications. A wide range of communication options (depending on the drive type) are available for establishing a communication link to the automation system:

- PROFINET
- PROFIBUS
- EtherNet/IP
- Modbus TCP
- Modbus RTU
- AS-Interface
- BACnet MS/TP

Applications

SINAMICS is the comprehensive converter family from Siemens designed for machine and plant engineering applications. SINAMICS offers solutions for all drive tasks:

- Simple pump and fan applications in the process industry
- Demanding single drives in centrifuges, presses, extruders, elevators, as well as conveyor and transport systems
- Drive line-ups in textile, plastic film, and paper machines as well as in rolling mill plants
- Highly dynamic servo drives for machine tools, as well as packaging and printing machines

Overview

SINAMICS as part of the Siemens modular automation system**Innovative, energy-efficient and reliable drive systems and applications as well as services for the entire drive train**

The solutions for drive technology place great emphasis on the highest productivity, energy efficiency and reliability for all torque ranges, performance and voltage classes.

Siemens offers not only the right innovative variable frequency drive for every drive application, but also a wide range of energy-efficient low voltage motors, geared motors, explosion-protected motors and high-voltage motors for combination with SINAMICS.

Furthermore, Siemens supports its customers with global pre-sales and after-sales services, with over 295 service points in 130 countries – and with special services e.g. application consulting or motion control solutions.

Energy efficiencyEnergy management process

Efficient energy management consultancy identifies the energy flows, determines the potential for making savings and implements them with focused activities.

Almost two thirds of the industrial power requirement is from electric motors. This makes it all the more important to use drive technology permitting energy consumption to be reduced effectively even in the configuration phase, and consequently to optimize plant availability and process stability. With SINAMICS, Siemens offers powerful energy efficient solutions which, depending on the application, enable a significant reduction in electricity costs.

G_D011_XX_00515b

System overview

1

The SINAMICS converter family

Overview

Up to 70 % potential for savings using variable speed operation

SINAMICS enables great potential for savings to be realized by controlling the motor speed. In particular, huge potential savings can be recovered from pumps, fans and compressors which are operated with mechanical throttle and valves. Here, changing to variable-speed drives brings enormous economic advantages. In contrast to mechanical control systems, the power consumption at partial load operation is always immediately adjusted to the demand at that time. So energy is no longer wasted, permitting savings of up to 60 % – in exceptional cases even up to 70 %. Variable-speed drives also offer clear advantages over mechanical control systems when it comes to maintenance and repair. Current spikes when starting up the motor and strong torque surges become things of the past – and the same goes for pressure waves in pipelines, cavitation or vibrations which cause sustainable damage to the plant. Smooth starting and ramp-down relieve the load on the mechanical system, ensuring a significantly longer service life of the entire drive train.

Regenerative feedback of braking energy

In conventional drive systems, the energy produced during braking is converted to heat using braking resistors. Energy produced during braking is efficiently recovered to the supply system by versions of SINAMICS G and SINAMICS S drives with regenerative feedback capability and these devices do not therefore need a braking resistor. This permits up to 60 % of the energy requirement to be saved, e.g. in lifting applications. Energy which can be reused at other locations on a machine. Furthermore, this reduced power loss simplifies the cooling of the system, enabling a more compact design.

Energy transparency in all configuration phases

Early on, in the configuration phase, the SIZER for Siemens Drives engineering tool (integrated into TIA Selection Tool) provides information on the specific energy requirement. The energy consumption across the entire drive train is visualized and compared with different plant concepts.

SINAMICS in combination with energy-saving motors

Engineering integration stretches beyond the SINAMICS converter family to higher-level automation systems, and to a broad spectrum of energy-efficient motors with a wide range of performance classes, which, compared to previous motors, are able to demonstrate up to 10 % greater efficiency.

Variants

Depending on the application, the SINAMICS range offers the ideal variant for any drive task.

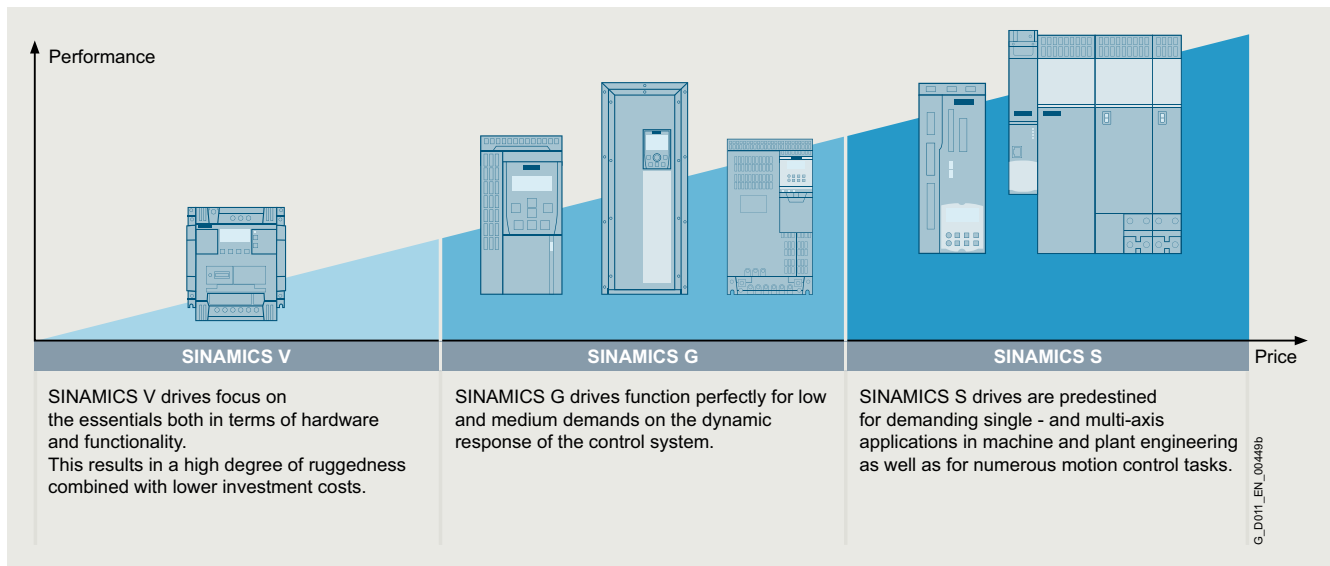

Overview

Platform concept

All SINAMICS variants are based on a platform concept. Joint hardware and software components, as well as standardized tools for dimensioning, configuration, and commissioning tasks ensure high-level integration across all components. SINAMICS handles a wide variety of drive tasks with no system gaps. The different SINAMICS variants can be easily combined with each other.

Quality management according to EN ISO 9001

SINAMICS conforms to the most exacting quality requirements. Comprehensive quality assurance measures in all development and production processes ensure a consistently high level of quality.

Of course, our quality management system is certified by an independent authority in accordance with EN ISO 9001.

Integrated system configuration

Siemens offers perfectly matched drive components with which you can meet your requirements. The drive components reveal their true strengths over the full range from engineering and commissioning through to operation: Integrated system configuration is performed using the Siemens Product Configurator: Just select a motor and a converter and design them with the SIZER for Siemens Drives engineering tool (integrated into TIA Selection Tool). The STARTER and SINAMICS Startdrive commissioning tools integrate the motor data and at the same time simplify efficient commissioning. All drive components are incorporated in the TIA Portal – this simplifies engineering, commissioning and diagnostics.

Low voltage											Direct voltage
Standard performance frequency converters		Distributed frequency converters	Industry-specific frequency converters		Servo converters			High performance frequency converters			DC converters
SINAMICS V20 G120C G120	SINAMICS G130 G150	SINAMICS G115D G120D SIMATIC ET 200pro FC-2	SINAMICS G120X	SINAMICS G180	SINAMICS V90 S200	SINAMICS S110	SINAMICS S210 S210 (New)	SINAMICS G220	SINAMICS S120 S120M	SINAMICS S150	SINAMICS DCM DCP ¹⁾
0.12 kW to 250 kW	75 kW to 2700 kW	0.37 kW to 7.5 kW	0.75 kW to 630 kW	2.2 kW to 6600 kW	0.05 kW to 7 kW	0.55 kW to 132 kW	0.05 kW to 7 kW	0.55 kW to 55 kW	0.55 kW to 5700 kW	75 kW to 1200 kW	6 kW to 30 MW
Pumps, fans, compressors, conveyor belts, mixers, mills, spinning machines, textile machines, refrigerated display counters, fitness equipment, ventilation systems, single-axis positioning applications in machine and plant engineering	Pumps, fans, compressors, conveyor belts, mixers, mills, extruders	Conveyor technology, single-axis positioning applications (G120D)	Pumps, fans, compressors, building management systems, process industry, HVAC, water/waste water industries	Pumps, fans, compressors, conveyor belts, extruders, mixers, mills, kneaders, centrifuges, separators	Handling machines, packaging machines, automatic assembly machines, metal forming machines, printing machines, winding and unwinding units	Single-axis positioning applications in machine and plant engineering	Packaging machines, handling equipment, feed and withdrawal devices, stacking units, automatic assembly machines, laboratory automation, wood, glass and ceramics industry, digital printing machines	Pumps, fans, compressors, conveyor belts, mixers, mills, spinning machines, textile machines, refrigerated display counters, fitness equipment, ventilation systems, single-axis positioning applications in machine and plant engineering	Production machines (packaging, textile and printing machines, paper machines, plastic processing machines), machine tools, plants, process lines and rolling mills, marine drives, test bays	Test bays, cross cutters, centrifuges	Rolling mill drives, wire-drawing machines, extruders and kneaders, cableways and lifts, test bay drives
Catalog D 31.1	Catalog D 11	Catalog D 31.2	Catalog D 31.5	Catalog D 18.1	Catalog D 33 D 37.1	Catalog D 31.1	Catalog D 32	Catalog D 36.1	Catalogs D 21.3, D 21.4 NC 62	Catalog D 21.3	Catalog D 23.1, SiePortal

Engineering tools (e.g. Siemens Product Configurator, TIA Selection Tool, SINAMICS DriveSim Basic/Advanced, STARTER and SINAMICS Startdrive)

¹⁾ DC/DC controllers, see SiePortal.

G_D011_EN_00450u

System overview

Drive selection

1

Overview

SINAMICS selection guide – typical applications

Use	Requirements for torque accuracy/speed accuracy/position accuracy/coordination of axes/functionality					
	Continuous motion			Non-continuous motion		
	Basic	Medium	High	Basic	Medium	High
Pumping, ventilating, compressing 	Centrifugal pumps Radial / axial fans Compressors	Centrifugal pumps Radial / axial fans Compressors	Eccentric screw pumps	Hydraulic pumps Metering pumps	Hydraulic pumps Metering pumps	Descaling pumps Hydraulic pumps
	V20 G120C G120X	G120X G130/G150 G180 ¹⁾ DCM	G220 S120	G120/G220	S110	S120
Moving 	Conveyor belts Roller conveyors Chain conveyors	Conveyor belts Roller conveyors Chain conveyors Lifting/lowering devices Elevators Escalators/moving walkways Indoor cranes Marine drives Cable railways	Elevators Container cranes Mining hoists Excavators for open-cast mining Test bays	Acceleration conveyors Storage and retrieval machines	Acceleration conveyors Storage and retrieval machines Cross cutters Reel changers	Storage and retrieval machines Robotics Pick & place Rotary indexing tables Cross cutters Roll feeds Engagers/disengagers
	V20 G115D G120C ET 200pro FC-2 ²⁾	G120/G220 G120D G130/G150 G180 ¹⁾	G220 S120 S150 DCM	V90 S200 G120/G220 G120D	S110 S210 DCM	S120 S210 DCM
Processing 	Mills Mixers Kneaders Crushers Agitators Centrifuges	Mills Mixers Kneaders Crushers Agitators Centrifuges Extruders Rotary furnaces	Extruders Winders/unwinders Lead/follower drives Calenders Main press drives Printing machines	Tubular bagging machines Single-axis motion control such as • Position profiles • Path profiles	Tubular bagging machines Single-axis motion control such as • Position profiles • Path profiles	Servo presses Rolling mill drives Multi-axis motion control such as • Multi-axis positioning • Cams • Interpolations
	V20 G120C	G120 G130/G150 G180 ¹⁾	G220 S120 S150 DCM	V90 S200 G120/G220	S110 S210	S120 S210 DCM
Machining 	Main drives for • Turning • Milling • Drilling	Main drives for • Drilling • Sawing	Main drives for • Turning • Milling • Drilling • Gear cutting • Grinding	Axis drives for • Turning • Milling • Drilling	Axis drives for • Drilling • Sawing	Axis drives for • Turning • Milling • Drilling • Lasering • Gear cutting • Grinding • Nibbling and punching
	S110	S110 S120	S120	S110	S110 S120	S120

Using the SINAMICS selection guide

The varying range of demands on modern variable frequency drives requires a large number of different types. Selecting the optimum drive has become a significantly more complex process. The application matrix shown simplifies this selection process considerably, by suggesting the ideal SINAMICS drive for examples of typical applications and requirements.

- The application type is selected from the vertical column
 - Pumping, ventilating, compressing
 - Moving
 - Processing
 - Machining
- The quality of the motion type is selected from the horizontal row
 - Basic
 - Medium
 - High

More information

Further information about SINAMICS is available on the internet at www.siemens.com/sinamics

Practical application examples and descriptions are available on the internet at www.siemens.com/sinamics-applications

¹⁾ Industry-specific converters.

²⁾ Information on the SIMATIC ET 200pro FC-2 frequency converter is available in Catalog D 31.2 and at www.siemens.com/et200pro-fc

Overview

SINAMICS S200 servo drive system



Example: SINAMICS S200 servo drive system consisting of a SINAMICS S200 servo converter, 200 ... 240 V 1 AC / 3 AC, PROFINET, frame size FSB, a SIMOTICS S-1FL2 servomotor, shaft height 30, metal hybrid connector, outlet direction drive end (DE) and MOTION-CONNECT 350 dual cables for power and communication

The SINAMICS S200 servo drive system is a single axis AC/AC servo drive system with compact design, high dynamic performance, ease of use and high reliability for motion control applications in standard servo motion market. It comprises SINAMICS S200 servo converters, SIMOTICS S-1FL2 servomotors, MOTION-CONNECT 350 and 380 connection systems and engineering tools.

System components

SINAMICS S200 servo converters

The SINAMICS S200 servo converters consist of a basic version and a standard version with pulse train input position control (PTI)¹⁾ or PROFINET RT/IRT (PN) to meet various needs of applications and works perfectly together with SIMATIC controllers.

- SINAMICS S200 Basic servo converters, power range 0.1 to 1 kW at 200 ... 240 V 1 AC / 3 AC
- SINAMICS S200 servo converters, power range 0.1 to 1 kW at 200 ... 240 V 1 AC / 3 AC and 0.2 to 7 kW at 380 ... 480 V 3 AC

SIMOTICS S-1FL2 servomotors

With flexible encoder options, including absolute encoder 17-bit singleturn, 21-bit singleturn and 21-bit singleturn + 12-bit multiturn, the system provides precise and accurate performance. The encoders can be used without a battery, making it easy to operate and maintenance.

- Low Inertia for high dynamic performance
- Medium Inertia for dynamic and smooth operational performance
- High Inertia for smooth operational performance

MOTION-CONNECT 350 and 380 connection systems

The cables are available in lengths of up to 30 m and one step further optimized in easy and secure installation with "one-push-lock" motor connecting solution for motor shaft heights 20, 30 and 40.

- MOTION-CONNECT 350 standard bending cables, which provides a connection solution for fixed installation applications

MOTION-CONNECT 380 high flexible bending cables, which provides a connection solution for drag chain installation applications that require high cable flexibility

Benefits

Performance-optimized

Dynamic

Ideal for dynamic applications thanks to fast current control:

- 62.5 μ s response time for the Pulse Train Input version (PTI)¹⁾
- 125 μ s response time for the PROFINET version (PN)
- 8 kHz PWM frequency

Fast

The system enables seamless communication to controllers via PROFINET IRT, providing fast and efficient data exchange and control.

Overload capacity

SIMOTICS S-1FL2 servomotors providing up to 350 % overload capacity, can handle sudden increases in load without compromising performance or efficiency, ensuring uninterrupted operation and increased productivity.

Compact

To enable more efficient use of cabinet space and improve application system design, both servo converters and servomotors are further optimized in compactness thanks to their high power density. More important, for side-by-side installation, SINAMICS S200 servo converters require only 1 mm for 200 V series and 10 mm for 400 V series.

Easy to use

Easy setup

All frame sizes of SINAMICS S200 servo converters have an integrated holding brake control²⁾ to dissipate the regenerative power for fast braking, which is easy and cost effective for applications.

Easy engineering

With directly integrated into SINAMICS Startdrive, and the embedded SINAMICS web server for SINAMICS S200, variety of user-friendly features make the servo drive system easy for engineering. Additionally, advanced One Button Tuning (OBT) enables machines to achieve a high dynamic performance within just seconds.

Easy implementation

The system is designed to meet global standards and certifications, including CE, UKCA, UL, RCM, EAC, KC and SEMI47, ensuring compliance with safety and quality regulations worldwide.

¹⁾ Available soon.

²⁾ Not available for SINAMICS S200 Basic servo converters.

System overview

SINAMICS S200 servo drive system

Benefits

Fit for future

Digital engineering journey

Unlock potential with a seamless digital engineering journey, from selection and commissioning to diagnosis via TIA Selection Tool, Siemens Product Configurator and TIA Portal. More important, SINAMICS S200 servo drive system can be simulated with SINAMICS DriveSim Basic.

Scalable system

As a scalable system, users can get a seamless integrated motion control system together with SIMATIC controllers (e.g. SIMATIC S7-1500).

Safety & Security

The system includes a safety concept that features Safety Integrated Basic Function Safe Torque Off (STO), ensuring safe and reliable operation. You achieve defense in depth thanks to User Management and Access Control (UMAC) providing always active industrial security service.

Application

Application examples

	SINAMICS S200 servo drive system		
	Low Inertia for high dynamic performance	Medium Inertia for dynamic and smooth operational performance	High Inertia for smooth operational performance
	200 V ... 240 V 1 AC / 3 AC	200 V ... 240 V 1 AC / 3 AC or 380 V ... 480 V 3 AC	380 V ... 480 V 3 AC
Electronics	<ul style="list-style-type: none"> • LED sorting machine • Glass cover inspection machine • PCB-AOI detection machine • PCB laser cutting machine • Screwing machine • PCB feeding and blanking machine • Assembly production line 	<ul style="list-style-type: none"> • Assembly production line 	–
Battery	<ul style="list-style-type: none"> • Stacking machine • EL filling machine • Busbar welding machine • Case insertion machine • Detection machine 	<ul style="list-style-type: none"> • Laser welding machine • Calendering and slitting machine • Die-cutting machine 	<ul style="list-style-type: none"> • Coating machine • Calendering and slitting machine • Die-cutting machine
Solar	<ul style="list-style-type: none"> • Stringer machine • Plating diamond machine • Screen printing machine • Auto sorting machine 	<ul style="list-style-type: none"> • Single crystal growing furnace • Batch texturing equipment • Squaring machine 	–
Packaging	<ul style="list-style-type: none"> • Filling and sealing machine • Bag packing machine 	<ul style="list-style-type: none"> • Pillow type packaging machine • Roller type blister packaging machine • Rigid box maker • Labelling machine 	<ul style="list-style-type: none"> • Auto roll-fed square bottom paper bag machine • Rigid box maker
Handling and robotics	<ul style="list-style-type: none"> • 3- or 4-axis delta picker • 4-axis cylindrical robot • 5-axis roller picker • 4-axis tripod robot 	<ul style="list-style-type: none"> • Cartesian portal 	<ul style="list-style-type: none"> • Truss manipulator
Wood working	<ul style="list-style-type: none"> • Edging machine • Panel sawing machine 	<ul style="list-style-type: none"> • Wooden engraving • Wooden machine center 	<ul style="list-style-type: none"> • Wooden engraving • Wooden machine center
Metal forming	–	–	<ul style="list-style-type: none"> • Punching machine • Engraving machine • Edging press machine
Other general machinery	–	<ul style="list-style-type: none"> • Diaper production line • Stator winding machine • Winding embedding machine • Battery swap station 	<ul style="list-style-type: none"> • Diaper production line • Stator winding machine • Copper foil green foil machine • Battery swap station

Design

System topology

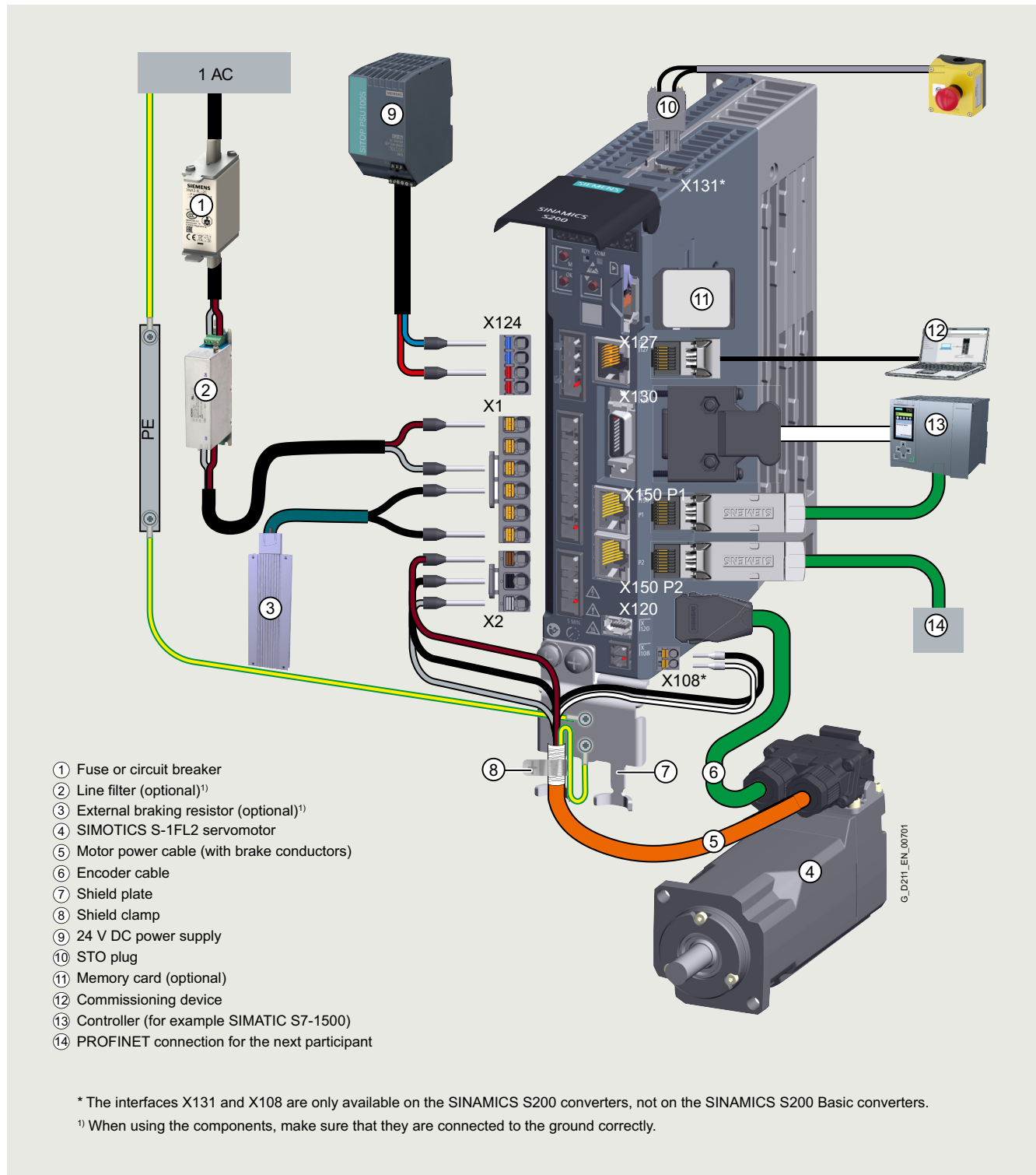

System connection overview SINAMICS S200 servo drive system, PROFINET version, 1 AC

System overview

SINAMICS S200 servo drive system

1

Design

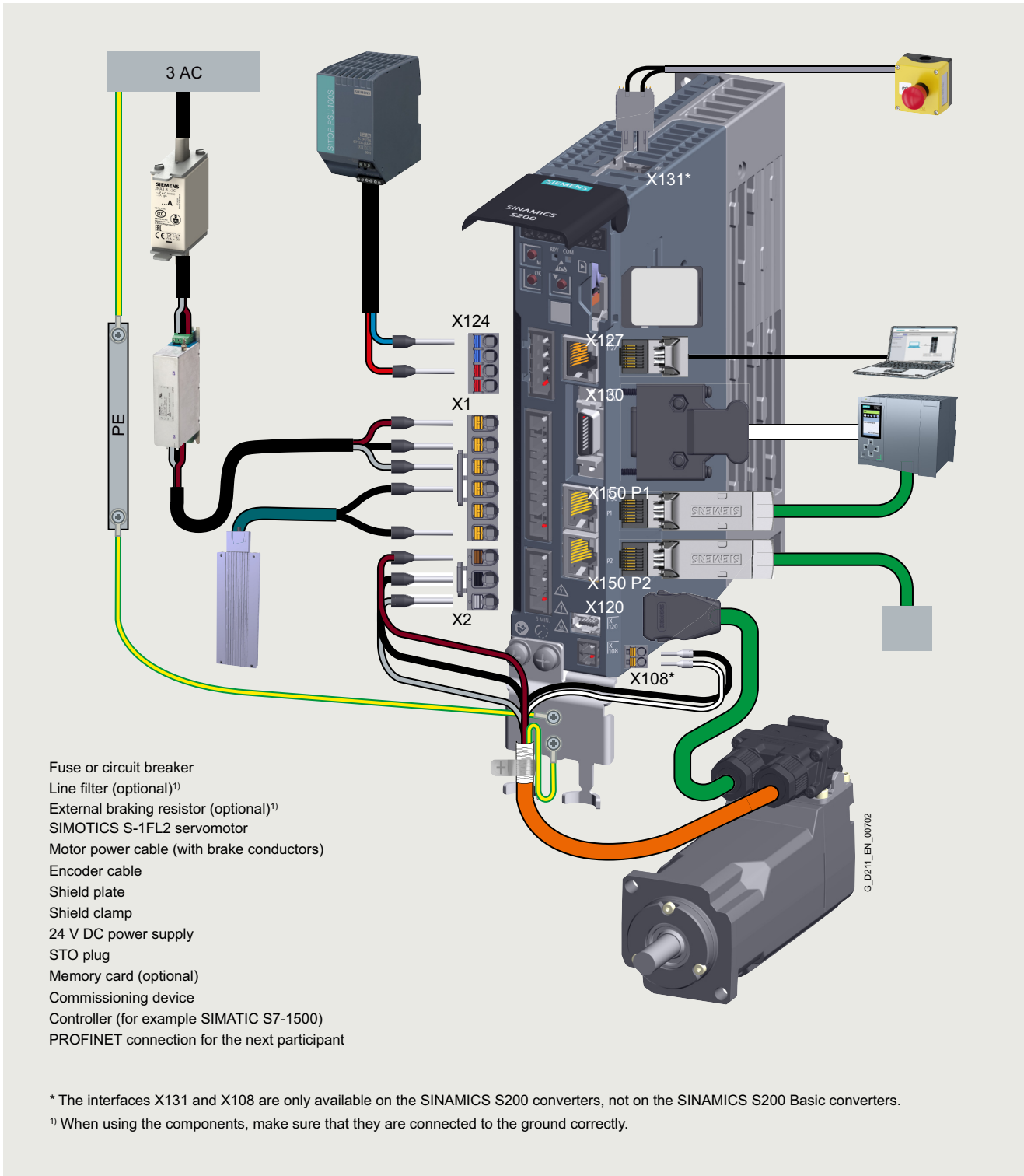

System connection overview SINAMICS S200 servo drive system, PROFINET version, 3 AC

Integration

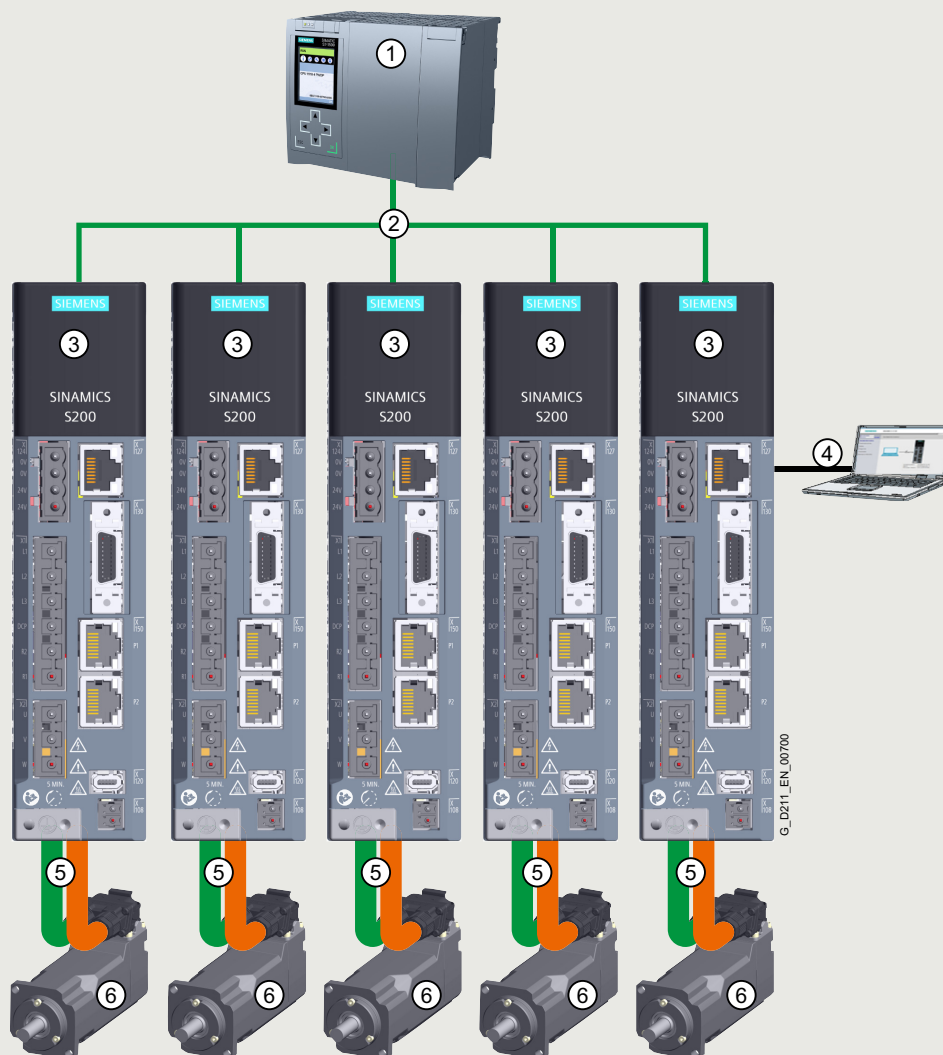

- ① Controller (for example SIMATIC S7-1500)
- ② Communication between the converter and the controller via PROFINET
- ③ SINAMICS S200 converter product line
- ④ Engineering via LAN with the web server in the converter
- ⑤ MOTION-CONNECT 350 or MOTION-CONNECT 380 cables for the motor power, the motor holding brake and the encoder connections
- ⑥ SIMOTICS S-1FL2 servomotor

System topology SINAMICS S200 servo drive system, PROFINET version

System overview

1

SINAMICS S200 servo drive system

Configuration

The following electronic configuring aids and engineering tools are available for the SINAMICS S200 servo drive system:

SINAMICS DriveSim Basic (firmware V6.2 or higher)

SINAMICS DriveSim Basic provides easy-to-use models for PROFIdrive-enabled SINAMICS converters, so you can create a digital twin of your drive.

More information is provided on the internet at: <https://www.siemens.com/global/en/products/drives/digitalization-in-drive-technology/virtualization.html>

You can find more information on SINAMICS DriveSim Basic in the Engineering tools section.

SINAMICS SELECTOR app (available soon)

Mobile selection guide for frequency converters

Siemens has developed the SINAMICS SELECTOR app as a practical tool for finding article numbers for your SINAMICS converters in a power range from 0.1 kW to 630 kW quickly and easily. Whether for SINAMICS V20, SINAMICS V90, SINAMICS G120C, SINAMICS G120P, SINAMICS G120X, SINAMICS G120, SINAMICS G220 (available soon), SINAMICS S200 (available soon) or SINAMICS S210: the app will provide you with the correct article numbers conveniently.

How does it work?

Simply select your application, the frequency converter you require, the rated power and device options as well as the necessary accessories.

Then you can save your selection and send it by email. Your preselection is the basis for an order specification with the dealer/Siemens.

You will find free downloads for Android and iOS here: www.siemens.com/sinamics-selector

Siemens Product Configurator

The Siemens Product Configurator helps you configure the optimum drive technology products for a number of applications – starting with gearboxes, motors, converters as well as the associated options and components and ending with controllers, software licenses and connection systems.

The Siemens Product Configurator can be used on the internet without requiring any installation. The Siemens Product Configurator can be found in SiePortal at the following address: www.siemens.com/spc

You can find more information on the Siemens Product Configurator in the Engineering tools section.

Drive dimensioning of the SINAMICS S200 servo drive system with the TIA Selection Tool

The SINAMICS S200 servo drive system is easily configured with the TIA Selection Tool under the Drive Dimensioning plug-in. It provides support when selecting the hardware and firmware components necessary to implement a drive task. The plug-in encompasses the configuration of the entire drive system and allows the handling of individual drives.

- Intuitive user interface, menu-based operation and help
- Configuration of the SINAMICS S200 servo drive system
- Adjustable traversing cycles and various mechanical systems integrated for single-axis applications
- Interface to the TIA Portal and SiePortal

The TIA Selection Tool is available for free on the internet at www.siemens.com/tia-selection-tool-standalone

You can find more information on the TIA Selection Tool in the Engineering tools section.

SINAMICS web server for SINAMICS S200

The converter can be brought easily and quickly into operation and optimized with the web server. Additional software does not need to be installed as access comes directly from a web browser.

You can find more information about the SINAMICS web server for SINAMICS S200 in the Engineering tools section.

SINAMICS Startdrive commissioning tool (TIA Portal)

SINAMICS Startdrive is a tool for configuring, commissioning, and diagnosing the SINAMICS converter family and is integrated into TIA Portal (V18 SP2 or higher).

The SINAMICS Startdrive has been optimized with regard to user friendliness and consistent use of the TIA Portal benefits of a common working environment for PLC, HMI and drives. SINAMICS firmware V6.2 or higher is required for SINAMICS S200.

The SINAMICS Startdrive Advanced license is required for the Safety Integrated acceptance test.

The SINAMICS Startdrive commissioning tool is available for free on the internet at: www.siemens.com/startdrive

You can find more information on the SINAMICS Startdrive commissioning tool in the Engineering tools section.

Technical specifications

General technical specifications

	SINAMICS S200 servo drive system		
	Low Inertia for high dynamic performance 200 V ... 240 V 1 AC / 3 AC	Medium Inertia for dynamic and smooth operational performance 200 V ... 240 V 1 AC / 3 AC or 380 V ... 480 V 3 AC	High Inertia for smooth operational performance 380 V ... 480 V 3 AC
SINAMICS S200 Basic servo converters			
Line voltage and power range	• 200 V ... 240 V 1 AC / 3 AC (-15 % / +10 %), 0.1 kW ... 1 kW	• 200 V ... 240 V 1 AC / 3 AC (-15 % / +10 %), 0.1 kW ... 1 kW	–
Communication	• Pulse train input position control (PTI) for Pulse Train Input version (PTI) ¹⁾ • PROFINET RT/IRT (PN) for PROFINET version (PN): speed control, basic positioner control (EPos)		
Frame sizes	• FSA, FSB, FSC	–	–
Safety Integrated Basic Functions	–	–	–
Holding brake control	• External relay and power supply required		
Degree of protection	• IP20		
SINAMICS S200 servo converters			
Line voltage and power range	• 200 V ... 240 V 1 AC / 3 AC (-15 % / +10 %), 0.1 kW ... 1 kW	• 200 V ... 240 V 1 AC / 3 AC (-15 % / +10 %), 0.1 kW ... 1 kW • 380 V ... 480 V 3 AC (-15 % / +10 %), 0.2 kW ... 1.5 kW	• 380 V ... 480 V 3 AC (-15 % / +10 %), 0.4 kW ... 7 kW
Communication	• Pulse train input position control (PTI) for Pulse Train Input version (PTI) ¹⁾ • PROFINET RT/IRT (PN) for PROFINET version (PN): speed control, basic positioner control (EPos)		
Frame sizes	• FSA, FSB, FSC	–	• FSA, FSB, FSC, FSD
Safety Integrated Basic Functions	• Safe Torque Off (STO)		
Degree of protection	• IP20		
Holding brake control	• Integrated holding brake control		
SIMOTICS S-1FL2 servomotors			
Shaft height	• 20, 30, 40, 52	• 30, 40, 48	• 45, 65, 90
Rated torque	• 0.16 ... 6.60 Nm (0.12 ... 4.87 lbf-ft)	• 0.64 ... 4.60 Nm (0.47 ... 3.39 lbf-ft)	• 1.27 ... 33.40 Nm (0.94 ... 24.63 lbf-ft)
Rated power	• 0.05 ... 2.1 kW	• 0.2 ... 1.45 kW	• 0.4 ... 7 kW
Rated speed	• 3000 rpm		• 3000 rpm for shaft height 45 • 2000 rpm for shaft heights 65, 90
Max. speed	• 6500 rpm for shaft heights 20, 30, 40 • 6000 rpm for shaft height 52	• 6500 rpm for shaft heights 30, 40 • 6000 rpm for shaft height 48	• 4000 rpm for shaft height 45 • 3000 rpm for shaft height 65 • 2000 rpm, 2500 rpm or 3000 rpm for shaft height 90
Encoder	• Absolute encoder 17-bit singleturn • Absolute encoder 21-bit singleturn • Absolute encoder 21-bit singleturn + 12-bit multiturn		
Degree of protection	• IP54 for shaft heights 20, 30, 40 Optional: IP65 • IP65, natural cooling, with shaft sealing ring for shaft height 52	• IP54 for shaft heights 30, 40 Optional: IP65 • IP65, natural cooling, with shaft sealing ring for shaft height 48	• IP65, natural cooling, with shaft sealing ring
Connection technology	• Metal hybrid connector for shaft heights 20, 30, 40 • Metal circular connector for shaft height 52	• Metal hybrid connector for shaft heights 30, 40 • Metal circular connector for shaft height 48	• Metal circular connector
MOTION-CONNECT 350 and 380 connection systems			
Cable	• Pre-assembled dual cables for power and signals for shaft heights 20, 30, 40 • Pre-assembled power and signal cables for shaft height 52	• Pre-assembled dual cables for power and signals for shaft heights 30, 40 • Pre-assembled power and signal cables for shaft height 48	• Pre-assembled power cables • Pre-assembled encoder cables • Pre-assembled brake cables
Length	3 m (9.84 ft), 5 m (16.4 ft), 7 m (23.0 ft), 10 m (32.8 ft), 15 m (49.2 ft), 20 m (65.6 ft), 30 m (98.4 ft)		
Outlet direction	Shaft heights 20, 30, 40: • Drive end (DE) • Non drive end (NDE) Shaft height 52: • Rotatable	Shaft heights 30, 40: • Drive end (DE) • Non drive end (NDE) Shaft height 48: • Rotatable	• Rotatable

¹⁾ Available soon.

System overview

Clicking to SiePortal

6SL3255-0AA00-5AA0



SINAMICS S200 servo drive system with SIMOTICS S-1FL2 Low Inertia servomotors

1

Selection and ordering data

SIMOTICS S-1FL2 servomotors – Further info in section "SIMOTICS S-1FL2 servomotors".

Max. speed	Rated power ¹⁾	Static torque	Rated torque ¹⁾	Max. torque ¹⁾	Rated current	Max. current	Article No.	Torque constant	Moment of inertia of rotor	Recommended load to motor inertia ratio, max.	Weight ²⁾	
n_{max}	P_N at $\Delta T=100$ K	M_0 at $\Delta T=100$ K	M_N at $\Delta T=100$ K	M_{max}	I_N at $\Delta T=100$ K	I_{max}			$J_{without}$ brake	J_{with} brake	$m_{without}$ brake	m_{with} brake
rpm	kW (hp)	Nm	Nm	Nm	A	A		Nm/A	kg cm ²	kg cm ²	kg	kg

SIMOTICS S-1FL2 Low Inertia servomotors – For high dynamic performance

Shaft height 20 – Rated speed n_N 3000 rpm – Line voltage 200 ... 240 V 1 AC / 3 AC

6500	0.05 (0.07)	0.16	0.16	0.56	0.81	3.1	1FL2102-2AG ■ ■ - ■ ■ C 0	0.2	0.017	0.022	40×	0.29	0.46
6500	0.10 (0.14)	0.32	0.32	1.12	0.76	2.95	1FL2102-4AG ■ ■ - ■ ■ C 0	0.42	0.029	0.034	30×	0.39	0.56

Shaft height 20 – Rated speed n_N 3000 rpm – Line voltage 380 ... 480 V 3 AC

6500	0.05 (0.07)	0.16	0.16	0.56	0.84	3.4	1FL2102-2AF ■ ■ - ■ ■ C 0	0.19	0.017	0.022	40×	0.29	0.45
6500	0.10 (0.14)	0.32	0.32	1.12	0.81	2.9	1FL2102-4AF ■ ■ - ■ ■ C 0	0.4	0.029	0.034	30×	0.38	0.55

Shaft height 30 – Rated speed n_N 3000 rpm – Line voltage 200 ... 240 V 1 AC / 3 AC

6500	0.20 (0.27)	0.64	0.64	2.24	1.28	4.8	1FL2103-2AG ■ ■ - ■ ■ C 0	0.5	0.08	0.11	30×	0.79	1.14
6500	0.40 (0.54)	1.27	1.27	4.45	2.4	8.7	1FL2103-4AG ■ ■ - ■ ■ C 0	0.53	0.155	0.185		1.16	1.5

Shaft height 30 – Rated speed n_N 3000 rpm – Line voltage 380 ... 480 V 3 AC

6500	0.20 (0.27)	0.64	0.64	2.24	1.3	4.8	1FL2103-2AF ■ ■ - ■ ■ C 0	0.49	0.08	0.11	30×	0.78	1.12
6500	0.40 (0.54)	1.27	1.27	4.45	1.3	4.8	1FL2103-4AF ■ ■ - ■ ■ C 0	0.98	0.155	0.185		1.14	1.49

Shaft height 40 – Rated speed n_N 3000 rpm – Line voltage 200 ... 240 V 1 AC / 3 AC

6500	0.75 (1.02)	2.4	2.4	8	4.4	16	1FL2104-2AG ■ ■ - ■ ■ C 0	0.55	0.5	0.58	20×	2.7	3.5
6500	1.00 (1.36)	3.2	3.2	10.8	4.4	16	1FL2104-4AG ■ ■ - ■ ■ C 0	0.73	0.63	0.71		3.3	4.1

Shaft height 40 – Rated speed n_N 3000 rpm – Line voltage 380 ... 480 V 3 AC

6500	0.75 (1.02)	2.4	2.4	8	2.1	7.6	1FL2104-2AF ■ ■ - ■ ■ C 0	1.14	0.5	0.58	20×	2.7	3.5
6500	1.00 (1.36)	3.2	3.2	10.8	3	10.9	1FL2104-4AF ■ ■ - ■ ■ C 0	1.07	0.63	0.71		3.3	4.1

Shaft height 52 – Rated speed n_N 3000 rpm – Line voltage 380 ... 480 V 3 AC

6000	1.45 (2.04)	5	4.6	15.9	4.35	18	1FL2105-2AF ■ 1 - ■ ■ B 0	1.08	1.71	2.54	20×	5.5	6.4
6000	2.10 (2.72)	8	6.6	25.3	5.6	24	1FL2105-4AF ■ 1 - ■ ■ B 0	1.19	2.65	3.48	15×	7.8	8.7

Brake

Without
Holding brake0
1

Degree of protection

IP54
IP65 (with shaft sealing ring)0
1

Shaft extension, feather key

Plain shaft
Shaft with feather key (half-key balancing)0
1

Encoder

Absolute encoder 17-bit singleturn
Absolute encoder 21-bit singleturn
Absolute encoder 21-bit singleturn + 12-bit multeturnH
S
M

Connection technology

Metal circular connector
Metal hybrid connectorB
CDetailed information on SINAMICS S200 is available on the internet at: www.siemens.com/sinamics-s200In addition, the Siemens Product Configurator can be used on the internet: www.siemens.com/sinamics-s200/configuration¹⁾ Rated torque, rated power and maximum torque listed in the table above allow for a production tolerance of 10 %.²⁾ Motor weight with absolute encoder 17-bit singleturn

Clicking to SiePortal

System overview

6SL3255-0AA00-5AA0



SINAMICS S200 servo drive system with SIMOTICS S-1FL2 Low Inertia servomotors

1

SINAMICS S200 servo converters Further info in section "SINAMICS S200 servo converters".		Line filter			Recommended standard fuse			Recommended circuit breaker	
		With one of the recommended line filters, IEC 61800-3 category C2 can be reached in combination with SINAMICS S200 for motor cable lengths up to 30 m (98.5 ft).			More information at www.siemens.com/sinamics-s200/ocpd				
Max. motor power	Frame size				IEC-compliant	UL/cUL-compliant	IEC/UL/cUL-compliant		
					/ 3NA3	/ Fuse type	3RV2		
kW (hp)	Article No.	V	A	Article No.	A Article No.	A Class	Article No.		
SINAMICS S200 and SINAMICS S200 Basic servo converters									
Line voltage 200 ... 240 V 1 AC / 3 AC									
0.10 (0.14)	6SL5 10-1BB10-1A 0	FSA	1 AC 200 ... 240 18	6SL5550-0XB21-8CA0	4	3NA3804	3	J	3RV2011-1EA10
			3 AC 200 ... 240 5	6SL3203-0BE15-0VA0					
Line voltage 380 ... 480 V 3 AC									
0.20 (0.27)	6SL5 10-1BE10-2A 0	FSA	3 AC 380 ... 480 5	6SL5550-0XE20-5CA0	4	3NA3804	3	J	3RV2011-1CA10
Line voltage 200 ... 240 V 1 AC / 3 AC									
0.20 (0.27)	6SL5 10-1BB10-2A 0	FSA	1 AC 200 ... 240 18	6SL5550-0XB21-8CA0	4	3NA3804	3	J	3RV2011-1EA10
			3 AC 200 ... 240 5	6SL3203-0BE15-0VA0					
0.40 (0.54)	6SL5 10-1BB10-4A 0	FSB	1 AC 200 ... 240 18	6SL5550-0XB21-8CA0	6	3NA3801	6	J	3RV2011-1HA10
			3 AC 200 ... 240 5	6SL3203-0BE15-0VA0					3RV2011-1EA10
Line voltage 380 ... 480 V 3 AC									
0.20 (0.27)	6SL5 5 10-1BE10-2A 0	FSA	3 AC 380 ... 480 5	6SL5550-0XE20-5CA0	4	3NA3804	3	J	3RV2011-1CA10
0.40 (0.54)	6SL5 5 10-1BE10-4A 0								3RV2021-1DA10
Line voltage 200 ... 240 V 1 AC / 3 AC									
0.75 (1.02)	6SL5 10-1BB10-8A 0	FSC	1 AC 200 ... 240 18	6SL5550-0XB21-8CA0	16	3NA3805	15	J	3RV2011-1KA10
			3 AC 200 ... 240 5	6SL3203-0BE15-0VA0					3RV2011-1HA10
1.00 (1.36)	6SL5 10-1BB11-0A 0		1 AC 200 ... 240 18	6SL5550-0XB21-8CA0	16	3NA3805	15	J	3RV2011-1KA10
			3 AC 200 ... 240 5	6SL3203-0BE15-0VA0					3RV2011-1JA10
Line voltage 380 ... 480 V 3 AC									
0.75 (1.02)	6SL5 5 10-1BE10-8A 0	FSB	3 AC 380 ... 480 5	6SL5550-0XE20-5CA0	10	3NA3803	10	J	3RV2021-1EA10
1.00 (1.36)	6SL5 5 10-1BE11-0A 0								3RV2021-1FA10
Line voltage 380 ... 480 V 3 AC									
1.75 (2.38)	6SL5 5 10-1BE11-5A 0	FSC	3 AC 380 ... 480 12	6SL5550-0XE21-2CA0	16	3NA3805	15	J	3RV2011-4AA10
2.50 (3.40)	6SL5 5 10-1BE12-5A 0						20		3RV2011-4AA10
Servo converter									
SINAMICS S200	5								
SINAMICS S200 Basic	6								
Version									
Pulse Train Input (PTI) ¹⁾	A								
PROFINET (PN)	F								

1) Available soon.

System overview

Clicking to SiePortal

6SL3255-0AA00-5AA0



SINAMICS S200 servo drive system with SIMOTICS S-1FL2 Low Inertia servomotors

Selection and ordering data

SIMOTICS S-1FL2 servomotors – Further info in section "SIMOTICS S-1FL2 servomotors"

Max. speed	Rated power ¹⁾	Static torque	Rated torque ¹⁾	Max. torque ¹⁾	Rated current	Max. current		Torque constant	Moment of inertia of rotor	Recommended load to motor inertia ratio, max.	Weight ²⁾	
n_{max}	P_N at $\Delta T=100\text{ K}$	M_0 at $\Delta T=100\text{ K}$	M_N at $\Delta T=100\text{ K}$	M_{max}	I_N at $\Delta T=100\text{ K}$	I_{max}	Article No.	Nm/A	$J_{without\ brake}$	$J_{with\ brake}$	$m_{without\ brake}$	$m_{with\ brake}$
rpm	kW (hp)	Nm	Nm	Nm	A	A			kg cm ²	kg cm ²	kg	kg

SIMOTICS S-1FL2 Low Inertia servomotors – For high dynamic performance

Shaft height 20 – Rated speed n_N 3000 rpm – Line voltage 200 ... 240 V 1 AC / 3 AC

6500	0.05 (0.07)	0.16	0.16	0.56	0.81	3.1	1FL2102-2AG ■ ■ - ■ ■ C 0	0.2	0.017	0.022	40x	0.29	0.46
6500	0.10 (0.14)	0.32	0.32	1.12	0.76	2.95	1FL2102-4AG ■ ■ - ■ ■ C 0	0.42	0.029	0.034	30x	0.39	0.56

Shaft height 20 – Rated speed n_N 3000 rpm – Line voltage 380 ... 480 V 3 AC

6500	0.05 (0.07)	0.16	0.16	0.56	0.84	3.4	1FL2102-2AF ■ ■ - ■ ■ C 0	0.19	0.017	0.022	40x	0.29	0.45
6500	0.10 (0.14)	0.32	0.32	1.12	0.81	2.9	1FL2102-4AF ■ ■ - ■ ■ C 0	0.4	0.029	0.034	30x	0.38	0.55

Shaft height 30 – Rated speed n_N 3000 rpm – Line voltage 200 ... 240 V 1 AC / 3 AC

6500	0.20 (0.27)	0.64	0.64	2.24	1.28	4.8	1FL2103-2AG ■ ■ - ■ ■ C 0	0.5	0.08	0.11	30x	0.79	1.14
6500	0.40 (0.54)	1.27	1.27	4.45	2.4	8.7	1FL2103-4AG ■ ■ - ■ ■ C 0	0.53	0.155	0.185		1.16	1.5

Shaft height 30 – Rated speed n_N 3000 rpm – Line voltage 380 ... 480 V 3 AC

6500	0.20 (0.27)	0.64	0.64	2.24	1.3	4.8	1FL2103-2AF ■ ■ - ■ ■ C 0	0.49	0.08	0.11	30x	0.78	1.12
6500	0.40 (0.54)	1.27	1.27	4.45	1.3	4.8	1FL2103-4AF ■ ■ - ■ ■ C 0	0.98	0.155	0.185		1.14	1.49

Shaft height 40 – Rated speed n_N 3000 rpm – Line voltage 200 ... 240 V 1 AC / 3 AC

6500	0.75 (1.02)	2.4	2.4	8	4.4	16	1FL2104-2AG ■ ■ - ■ ■ C 0	0.55	0.5	0.58	20x	2.7	3.5
6500	1.00 (1.36)	3.2	3.2	10.8	4.4	16	1FL2104-4AG ■ ■ - ■ ■ C 0	0.73	0.63	0.71		3.3	4.1

Shaft height 40 – Rated speed n_N 3000 rpm – Line voltage 380 ... 480 V 3 AC

6500	0.75 (1.02)	2.4	2.4	8	2.1	7.6	1FL2104-2AF ■ ■ - ■ ■ C 0	1.14	0.5	0.58	20x	2.7	3.5
6500	1.00 (1.36)	3.2	3.2	10.8	3	10.9	1FL2104-4AF ■ ■ - ■ ■ C 0	1.07	0.63	0.71		3.3	4.1

Shaft height 52 – Rated speed n_N 3000 rpm – Line voltage 380 ... 480 V 3 AC

6000	1.45 (2.04)	5	4.6	15.9	4.35	18	1FL2105-2AF ■ 1 - ■ ■ B 0	1.08	1.71	2.54	20x	5.5	6.4
6000	2.10 (2.72)	8	6.6	25.3	5.6	24	1FL2105-4AF ■ 1 - ■ ■ B 0	1.19	2.65	3.48	15x	7.8	8.7

Brake

Without	0
Holding brake	1

Degree of protection

IP54	0
IP65 (with shaft sealing ring)	1

Shaft extension, feather key

Plain shaft	0
Shaft with feather key (half-key balancing)	1

Encoder

Absolute encoder 17-bit singleturn	H S M
Absolute encoder 21-bit singleturn	
Absolute encoder 21-bit singleturn + 12-bit multeturn	

Connection technology

Metal circular connector	B C
Metal hybrid connector	

Detailed information on SINAMICS S200 is available on the internet at: www.siemens.com/sinamics-s200In addition, the Siemens Product Configurator can be used on the internet: www.siemens.com/sinamics-s200/configuration

¹⁾ Rated torque, rated power and maximum torque listed in the table above allow for a production tolerance of 10 %.

²⁾ Motor weight with absolute encoder 17-bit singleturn.

6SL3255-0AA00-5AA0



SINAMICS S200 servo drive system with SIMOTICS S-1FL2 Low Inertia servomotors

1

MOTION-CONNECT connection systems – Further info in section "MOTION-CONNECT 350 and 380 connection systems".					
Pre-assembled dual cables for power and communication			Pre-assembled power cables		Pre-assembled dual cables for communication
No. of cores × cross-section mm ²	Article No.		No. of cores × cross-section mm ²	Article No.	No. of cores × cross-section mm ² Article No.

MOTION-CONNECT connection systems

4 × 0.75 / 3 × 2 × 0.25 ¹⁾ or 4 × 0.75 / 3 × 2 × 0.25 ¹⁾ / 2 × 0.38	6FX3 02-7 01-1 0	-	-	-	-
4 × 0.75 / 3 × 2 × 0.25 ¹⁾ or 4 × 0.75 / 3 × 2 × 0.25 ¹⁾ / 2 × 0.38	6FX3 02-7 01-1 0	-	-	-	-
4 × 0.75 / 3 × 2 × 0.25 ¹⁾ or 4 × 0.75 / 3 × 2 × 0.25 ¹⁾ / 2 × 0.38	6FX3 02-7 01-1 0	-	-	-	-
4 × 0.75 / 3 × 2 × 0.25 ¹⁾ or 4 × 0.75 / 3 × 2 × 0.25 ¹⁾ / 2 × 0.38	6FX3 02-7 01-1 0	-	-	-	-
4 × 0.75 / 3 × 2 × 0.25 ¹⁾ or 4 × 0.75 / 3 × 2 × 0.25 ¹⁾ / 2 × 0.38	6FX3 02-7 01-1 0	-	-	-	-
4 × 0.75 / 3 × 2 × 0.25 ¹⁾ or 4 × 0.75 / 3 × 2 × 0.25 ¹⁾ / 2 × 0.38	6FX3 02-7 01-1 0	-	-	-	-
-	-	4 × 0.75 or 4 × 0.75 / 2 × 0.38	6FX3 02-5 K32-1 0	3 × 2 × 0.25 ¹⁾	6FX3 02-2XB11-1 0

Connection system					
MOTION-CONNECT 350	5			5	5
MOTION-CONNECT 380	8			8	8
Brake cores					
Without		C		C	
With		D		D	
Outlet direction					
Drive end (DE)					
Non drive end (NDE)		D			
Length					
3 m		A	D	A	D
5 m		A	F	A	F
7 m		A	H	A	H
10 m		B	A	B	A
15 m		B	F	B	F
20 m		C	A	C	A
30 m		D	A	D	A

¹⁾ No. of cores × cross-section for encoder cable in mm² for:
 Length <20 m: 3 × 2 × 0.25
 Length ≥ 20 m: 2 × 2 × 0.25 + 2 × 0.38

System overview

[Clicking to SiePortal](#)

6SL3255-0AA00-5AA0



1

SINAMICS S200 servo drive system with SIMOTICS S-1FL2 Low Inertia servomotors

Selection and ordering data

SIMOTICS S-1FL2 servomotors – Further info in section "SIMOTICS S-1FL2 servomotors"

Max. speed	Rated power ¹⁾	Static torque	Rated torque ¹⁾	Max. torque ¹⁾	Rated current	Max. current		Torque constant	Moment of inertia of rotor	Recom- mended load to motor inertia ratio, max.	Weight ²⁾	
n_{max}	P_N at $\Delta T=100\text{ K}$	M_0 at $\Delta T=100\text{ K}$	M_N at $\Delta T=100\text{ K}$	M_{max}	I_N at $\Delta T=100\text{ K}$	I_{max}	Article No.		$J_{without\ brake}$	$J_{with\ brake}$	$m_{without\ brake}$	$m_{with\ brake}$
rpm	kW (hp)	Nm	Nm	Nm	A	A		Nm/A	kg cm ²	kg cm ²	kg	kg

SIMOTICS S-1FL2 Low Inertia servomotors – For high dynamic performance

Shaft height 20 – Rated speed n_N 3000 rpm – Line voltage 200 ... 240 V 1 AC / 3 AC

6500	0.05 (0.07)	0.16	0.16	0.56	0.81	3.1	1FL2102-2AG	0.2	0.017	0.022	40x	0.29	0.46
6500	0.10 (0.14)	0.32	0.32	1.12	0.76	2.95	1FL2102-4AG	0.42	0.029	0.034	30x	0.39	0.56

Shaft height 20 – Rated speed n_N 3000 rpm – Line voltage 380 ... 480 V 3 AC

6500	0.05 (0.07)	0.16	0.16	0.56	0.84	3.4	1FL2102-2AF	0.19	0.017	0.022	40x	0.29	0.45
6500	0.10 (0.14)	0.32	0.32	1.12	0.81	2.9	1FL2102-4AF	0.4	0.029	0.034	30x	0.38	0.55

Shaft height 30 – Rated speed n_N 3000 rpm – Line voltage 200 ... 240 V 1 AC / 3 AC

6500	0.20 (0.27)	0.64	0.64	2.24	1.28	4.8	1FL2103-2AG	0.5	0.08	0.11	30x	0.79	1.14
6500	0.40 (0.54)	1.27	1.27	4.45	2.4	8.7	1FL2103-4AG	0.53	0.155	0.185		1.16	1.5

Shaft height 30 – Rated speed n_N 3000 rpm – Line voltage 380 ... 480 V 3 AC

6500	0.20 (0.27)	0.64	0.64	2.24	1.3	4.8	1FL2103-2AF	0.49	0.08	0.11	30x	0.78	1.12
6500	0.40 (0.54)	1.27	1.27	4.45	1.3	4.8	1FL2103-4AF	0.98	0.155	0.185		1.14	1.49

Shaft height 40 – Rated speed n_N 3000 rpm – Line voltage 200 ... 240 V 1 AC / 3 AC

6500	0.75 (1.02)	2.4	2.4	8	4.4	16	1FL2104-2AG	0.55	0.5	0.58	20x	2.7	3.5
6500	1.00 (1.36)	3.2	3.2	10.8	4.4	16	1FL2104-4AG	0.73	0.63	0.71		3.3	4.1

Shaft height 40 – Rated speed n_N 3000 rpm – Line voltage 380 ... 480 V 3 AC

6500	0.75 (1.02)	2.4	2.4	8	2.1	7.6	1FL2104-2AF	1.14	0.5	0.58	20x	2.7	3.5
6500	1.00 (1.36)	3.2	3.2	10.8	3	10.9	1FL2104-4AF	1.07	0.63	0.71		3.3	4.1

Shaft height 52 – Rated speed n_N 3000 rpm – Line voltage 380 ... 480 V 3 AC

6000	1.45 (2.04)	5	4.6	15.9	4.35	18	1FL2105-2AF	1.08	1.71	2.54	20x	5.5	6.4
6000	2.10 (2.72)	8	6.6	25.3	5.6	24	1FL2105-4AF	1.19	2.65	3.48	15x	7.8	8.7

Brake

Without	0
Holding brake	1

Degree of protection

IP54	0
IP65 (with shaft sealing ring)	1

Shaft extension, feather key

Plain shaft	0
Shaft with feather key (half-key balancing)	1

Encoder

Absolute encoder 17-bit singleturn	H S M
Absolute encoder 21-bit singleturn	
Absolute encoder 21-bit singleturn + 12-bit multiturn	

Connection technology

Metal circular connector	B C
Metal hybrid connector	

Detailed information on SINAMICS S200 is available on the internet at: www.siemens.com/sinamics-s200

In addition, the Siemens Product Configurator can be used on the internet: www.siemens.com/sinamics-s200/configuration

¹⁾ Rated torque, rated power and maximum torque listed in the table above allow for a production tolerance of 10 %.

²⁾ Motor weight with absolute encoder 17-bit singleturn.

6SL3255-0AA00-5AA0



SINAMICS S200 servo drive system with SIMOTICS S-1FL2 Low Inertia servomotors

1

MOTION-CONNECT connection systems (continued) – Further info in section "MOTION-CONNECT 350 and 380 connection systems".						
Pre-assembled dual cables for communication		Connectors				
SINAMICS S200 – Brake on the 1FL2 servomotor with holding brake		Drive end (DE) direction	Non drive end (NDE) direction	Motor side		
No. of cores x cross-section mm ²	Article No.	for hybrid connection Article No.	for hybrid connection Article No.	for power connection Article No.	for absolute encoder Article No.	for brake Article No.

MOTION-CONNECT connection systems (continued)

-	-	6FX2003-3HD00	6FX2003-3HN00	-	-	-
-	-	6FX2003-3HD00	6FX2003-3HN00	-	-	-
-	-	6FX2003-3HD00	6FX2003-3HN00	-	-	-
-	-	6FX2003-3HD00	6FX2003-3HN00	-	-	-
-	-	6FX2003-3HD00	6FX2003-3HN00	-	-	-
-	-	6FX2003-3HD00	6FX2003-3HN00	-	-	-
-	-	-	-	6FX2003-0LL63	6FX2003-0DB63	- (in power connector)

MOTION-CONNECT connectors for SINAMICS S200 servo converters

Crimp contacts "power and PE" (2000 pieces per reel) for hybrid connection	Crimp contacts "signal" (2000 pieces per reel) for hybrid connection	Connectors converter side		for brake
6FX2003-7HP00	6FX2003-7HS00	for power connection	IX signal connector, C-code, for absolute encoder	6FX2003-0DE61
-	-	-	-	-

System overview

Clicking to SiePortal

6SL3255-0AA00-5AA0



SINAMICS S200 servo drive system with SIMOTICS S-1FL2 Medium Inertia servomotors

Selection and ordering data

SIMOTICS S-1FL2 servomotors – Further info in section "SIMOTICS S-1FL2 servomotors".

Max. speed	Rated power ¹⁾	Static torque	Rated torque ¹⁾	Max. torque ¹⁾	Rated current	Max. current		Torque constant	Moment of inertia of rotor		Recommended load to motor inertia ratio, max.	Weight ²⁾	
n_{max}	P_N at $\Delta T=100$ K	M_0 at $\Delta T=100$ K	M_N at $\Delta T=100$ K	M_{max}	I_N at $\Delta T=100$ K	I_{max}	Article No.	Nm/A	$J_{without}$ brake	J_{with} brake		$m_{without}$ brake	m_{with} brake
rpm	kW (hp)	Nm	Nm	Nm	A	A			kg cm ²	kg cm ²		kg	kg

SIMOTICS S-1FL2 Medium Inertia servomotors – For dynamic and smooth operational performance

Shaft height 30 – Rated speed n_N 3000 rpm – Line voltage 200 ... 240 V 1 AC / 3 AC

6500	0.20 (0.27)	0.64	0.64	2.24	1.33	4.8	1FL2203-2AG ■ ■ - ■ ■ C 0	0.48	0.18	0.21	30×	0.76	1.11
6500	0.40 (0.54)	1.27	1.27	4.45	2.4	8.7	1FL2203-4AG ■ ■ - ■ ■ C 0	0.53	0.35	0.38		1.11	1.46

Shaft height 30 – Rated speed n_N 3000 rpm – Line voltage 380 ... 480 V 3 AC

6500	0.20 (0.27)	0.64	0.64	2.24	1.3	4.8	1FL2203-2AF ■ ■ - ■ ■ C 0	0.49	0.18	0.21	30×	0.77	1.12
6500	0.40 (0.54)	1.27	1.27	4.45	1.3	4.8	1FL2203-4AF ■ ■ - ■ ■ C 0	0.98	0.35	0.38		1.09	1.44

Shaft height 40 – Rated speed n_N 3000 rpm – Line voltage 200 ... 240 V 1 AC / 3 AC

6500	0.75 (1.02)	2.4	2.4	7.5	4.4	14.2	1FL2204-2AG ■ ■ - ■ ■ C 0	0.55	1.23	1.31	15×	2.6	3.4
6500	1.00 (1.36)	3.2	3.2	11.3	4.4	16	1FL2204-4AG ■ ■ - ■ ■ C 0	0.73	1.61	1.69		3.1	3.9

Shaft height 40 – Rated speed n_N 3000 rpm – Line voltage 380 ... 480 V 3 AC

6500	0.75 (1.02)	2.4	2.4	7.5	2.25	7.1	1FL2204-2AF ■ ■ - ■ ■ C 0	1.07	1.23	1.31	15×	2.6	3.4
6500	1.00 (1.36)	3.2	3.2	10	3	9.9	1FL2204-4AF ■ ■ - ■ ■ C 0	1.07	1.61	1.69		3.1	3.9

Shaft height 48 – Rated speed n_N 3000 rpm – Line voltage 380 ... 480 V 3 AC

6000	0.94 (1.36)	3.6	3	11.5	2.5	9.5	1FL2205-2AF ■ 1 - ■ ■ B 0	1.24	3.15	4.03	15×	3.6	4.7
6000	1.45 (2.04)	6	4.6	19.3	3.75	15.1	1FL2205-4AF ■ 1 - ■ ■ B 0	1.28	5.1	5.98		5	6.1

Brake

Without
Holding brake0
1

Degree of protection

IP54
IP65 (with shaft sealing ring)0
1

Shaft extension, feather key

Plain shaft
Shaft with feather key (half-key balancing)0
1

Encoder

Absolute encoder 17-bit singleturn
Absolute encoder 21-bit singleturn
Absolute encoder 21-bit singleturn + 12-bit multeturnH
S
M

Connection technology

Metal circular connector
Metal hybrid connectorB
CDetailed information on SINAMICS S200 is available on the internet at: www.siemens.com/sinamics-s200In addition, the Siemens Product Configurator can be used on the internet: www.siemens.com/sinamics-s200/configuration

1) Rated torque, rated power and maximum torque listed in the table above allow for a production tolerance of 10 %.

2) Motor weight with absolute encoder 17-bit singleturn.

Clicking to SiePortal

System overview

6SL3255-0AA00-5AA0



SINAMICS S200 servo drive system with SIMOTICS S-1FL2 Medium Inertia servomotors

1

SINAMICS S200 servo converters Further info in section "SINAMICS S200 servo converters".		Line filter		Recommended standard fuse			Recommended circuit breaker	
				More information at www.siemens.com/sinamics-s200/ocpd				
Max. motor power	Frame size	With one of the recommended line filters, IEC 61800-3 category C2 can be reached in combination with SINAMICS S200 for motor cable lengths up to 30 m (98.5 ft).		IEC-compliant	UL/cUL-compliant	IEC/UL/cUL-compliant		
		Line voltage	I_N	/ 3NA3	/ Fuse type	3RV2		
kW (hp)	Article No.	V	A Article No.	A Article No.	A Class	Article No.		
SINAMICS S200 and SINAMICS S200 Basic servo converters								
Line voltage 200 ... 240 V 1 AC / 3 AC								
0.20 (0.27)	6SL5 10-1BB10-2A 0	FSA	1 AC 200 ... 240 18	6SL5550-0XB21-8CA0	4	3NA3804	3 J	3RV2011-1EA10
			3 AC 200 ... 240 5	6SL3203-0BE15-0VA0				
0.40 (0.54)	6SL5 10-1BB10-4A 0	FSB	1 AC 200 ... 240 18	6SL5550-0XB21-8CA0	6	3NA3801	6 J	3RV2011-1HA10
			3 AC 200 ... 240 5	6SL3203-0BE15-0VA0				3RV2011-1EA10
Line voltage 380 ... 480 V 3 AC								
0.20 (0.27)	6SL5 5 10-1BE10-2A 0	FSA	3 AC 380 ... 480 5	6SL5550-0XE20-5CA0	4	3NA3804	3 J	3RV2011-1CA10
0.40 (0.54)	6SL5 5 10-1BE10-4A 0							3RV2011-1DA10
Line voltage 200 ... 240 V 1 AC / 3 AC								
0.75 (1.02)	6SL5 10-1BB10-8A 0	FSC	1 AC 200 ... 240 18	6SL5550-0XB21-8CA0	16	3NA3805	15 J	3RV2011-1KA10
			3 AC 200 ... 240 5	6SL3203-0BE15-0VA0				3RV2011-1HA10
1.00 (1.36)	6SL5 10-1BB11-0A 0		1 AC 200 ... 240 18	6SL5550-0XB21-8CA0	16	3NA3805	15 J	3RV2011-1KA10
			3 AC 200 ... 240 5	6SL3203-0BE15-0VA0				3RV2011-1JA10
Line voltage 380 ... 480 V 3 AC								
0.75 (1.02)	6SL5 5 10-1BE10-8A 0	FSB	3 AC 380 ... 480 5	6SL5550-0XE20-5CA0	10	3NA3803	10 J	3RV2011-1EA10
1.00 (1.36)	6SL5 5 10-1BE11-0A 0							3RV2011-1FA10
Line voltage 380 ... 480 V 3 AC								
1.00 (1.36)	6SL5 5 10-1BE11-0A 0	FSB	3 AC 380 ... 480 5	6SL3203-0BE15-0VA0	10	3NA3803	10 J	3RV2011-1FA10
1.75 (2.38)	6SL5 5 10-1BE11-5A 0	FSC	3 AC 380 ... 480 12	6SL5550-0XE21-2CA0	16	3NA3805	15	3RV2011-4AA10
Servo converter								
SINAMICS S200	5							
SINAMICS S200 Basic	6							
Version								
Pulse Train Input (PTI) ¹⁾	A							
PROFINET (PN)	F							

1) Available soon.

System overview

Clicking to SiePortal

6SL3255-0AA00-5AA0



SINAMICS S200 servo drive system with SIMOTICS S-1FL2 Medium Inertia servomotors

Selection and ordering data

SIMOTICS S-1FL2 servomotors – Further info in section "SIMOTICS S-1FL2 servomotors".

Max. speed	Rated power ¹⁾	Static torque	Rated torque ¹⁾	Max. torque ¹⁾	Rated current	Max. current		Torque constant	Moment of inertia of rotor		Recommended load to motor inertia ratio, max.	Weight ²⁾	
n_{max}	P_N at $\Delta T=100\text{ K}$	M_0 at $\Delta T=100\text{ K}$	M_N at $\Delta T=100\text{ K}$	M_{max}	I_N at $\Delta T=100\text{ K}$	I_{max}	Article No.	Nm/A	$J_{without\ brake}$	$J_{with\ brake}$		$m_{without\ brake}$	$m_{with\ brake}$
rpm	kW (hp)	Nm	Nm	Nm	A	A			kg cm ²	kg cm ²		kg	kg

SIMOTICS S-1FL2 Medium Inertia servomotors – For dynamic and smooth operational performance

Shaft height 30 – Rated speed n_N 3000 rpm – Line voltage 200 ... 240 V 1 AC / 3 AC

6500	0.20 (0.27)	0.64	0.64	2.24	1.33	4.8	1FL2203-2AG ■ ■ - ■ ■ C 0	0.48	0.18	0.21	30x	0.76	1.11
6500	0.40 (0.54)	1.27	1.27	4.45	2.4	8.7	1FL2203-4AG ■ ■ - ■ ■ C 0	0.53	0.35	0.38		1.11	1.46

Shaft height 30 – Rated speed n_N 3000 rpm – Line voltage 380 ... 480 V 3 AC

6500	0.20 (0.27)	0.64	0.64	2.24	1.3	4.8	1FL2203-2AF ■ ■ - ■ ■ C 0	0.49	0.18	0.21	30x	0.77	1.12
6500	0.40 (0.54)	1.27	1.27	4.45	1.3	4.8	1FL2203-4AF ■ ■ - ■ ■ C 0	0.98	0.35	0.38		1.09	1.44

Shaft height 40 – Rated speed n_N 3000 rpm – Line voltage 200 ... 240 V 1 AC / 3 AC

6500	0.75 (1.02)	2.4	2.4	7.5	4.4	14.2	1FL2204-2AG ■ ■ - ■ ■ C 0	0.55	1.23	1.31	15x	2.6	3.4
6500	1.00 (1.36)	3.2	3.2	11.3	4.4	16	1FL2204-4AG ■ ■ - ■ ■ C 0	0.73	1.61	1.69		3.1	3.9

Shaft height 40 – Rated speed n_N 3000 rpm – Line voltage 380 ... 480 V 3 AC

6500	0.75 (1.02)	2.4	2.4	7.5	2.25	7.1	1FL2204-2AF ■ ■ - ■ ■ C 0	1.07	1.23	1.31	15x	2.6	3.4
6500	1.00 (1.36)	3.2	3.2	10	3	9.9	1FL2204-4AF ■ ■ - ■ ■ C 0	1.07	1.61	1.69		3.1	3.9

Shaft height 48 – Rated speed n_N 3000 rpm – Line voltage 380 ... 480 V 3 AC

6000	0.94 (1.36)	3.6	3	11.5	2.5	9.5	1FL2205-2AF ■ 1 - ■ ■ B 0	1.24	3.15	4.03	15x	3.6	4.7
6000	1.45 (2.04)	6	4.6	19.3	3.75	15.1	1FL2205-4AF ■ 1 - ■ ■ B 0	1.28	5.1	5.98		5	6.1

Brake

Without
Holding brake0
1

Degree of protection

IP54
IP65 (with shaft sealing ring)0
1

Shaft extension, feather key

Plain shaft
Shaft with feather key (half-key balancing)0
1

Encoder

Absolute encoder 17-bit singleturn
Absolute encoder 21-bit singleturn
Absolute encoder 21-bit singleturn + 12-bit multiturnH
S
M

Connection technology

Metal circular connector
Metal hybrid connectorB
CDetailed information on SINAMICS S200 is available on the internet at: www.siemens.com/sinamics-s200In addition, the Siemens Product Configurator can be used on the internet: www.siemens.com/sinamics-s200/configuration

¹⁾ Rated torque, rated power and maximum torque listed in the table above allow for a production tolerance of 10 %.

²⁾ Motor weight with absolute encoder 17-bit singleturn.

6SL3255-0AA00-5AA0



SINAMICS S200 servo drive system with SIMOTICS S-1FL2 Medium Inertia servomotors

1

MOTION-CONNECT connection systems – Further info in section "MOTION-CONNECT 350 and 380 connection systems".						
Pre-assembled dual cables for power and communication		Pre-assembled power cables		Pre-assembled dual cables for communication		
No. of cores × cross-section mm ²	Article No.	No. of cores × cross-section mm ²	Article No.	No. of cores × cross-section mm ²	Article No.	
MOTION-CONNECT connection systems						
4 × 0.75 / 3 × 2 × 0.25 ¹⁾ or 4 × 0.75 / 3 × 2 × 0.25 ¹⁾ / 2 × 0.38	6FX3 02-7 01-1 0	-	-	-	-	
4 × 0.75 / 3 × 2 × 0.25 ¹⁾ or 4 × 0.75 / 3 × 2 × 0.25 ¹⁾ / 2 × 0.38	6FX3 02-7 01-1 0	-	-	-	-	
4 × 0.75 / 3 × 2 × 0.25 ¹⁾ or 4 × 0.75 / 3 × 2 × 0.25 ¹⁾ / 2 × 0.38	6FX3 02-7 01-1 0	-	-	-	-	
4 × 0.75 / 3 × 2 × 0.25 ¹⁾ or 4 × 0.75 / 3 × 2 × 0.25 ¹⁾ / 2 × 0.38	6FX3 02-7 01-1 0	-	-	-	-	
-	-	4 × 0.75 or 4 × 0.75 / 2 × 0.38	6FX3 02-5 K32-1 0	3 × 2 × 0.25 ¹⁾	6FX3 02-2XB11-1 0	
Connection system MOTION-CONNECT 350 MOTION-CONNECT 380	5 8			5 8		5 8
Brake cores Without With		C D		C D		
Outlet direction Drive end (DE) Non drive end (NDE)		D N				
Length 3 m 5 m 7 m 10 m 15 m 20 m 30 m		A A A B B C D	D F H A A A A		A A A B B C D	D F H A A B C D

¹⁾ No. of cores × cross-section for encoder cable in mm² for:
 Length <20 m: 3 × 2 × 0.25
 Length ≥ 20 m: 2 × 2 × 0.25 + 2 × 0.38

System overview

Clicking to SiePortal

6SL3255-0AA00-5AA0



SINAMICS S200 servo drive system with SIMOTICS S-1FL2 Medium Inertia servomotors

Selection and ordering data

SIMOTICS S-1FL2 servomotors – Further info in section "SIMOTICS S-1FL2 servomotors".

Max. speed	Rated power ¹⁾	Static torque	Rated torque ¹⁾	Max. torque ¹⁾	Rated current	Max. current		Torque constant	Moment of inertia of rotor		Recommended load to motor inertia ratio, max.	Weight ²⁾	
n_{max}	P_N at $\Delta T=100$ K	M_0 at $\Delta T=100$ K	M_N at $\Delta T=100$ K	M_{max}	I_N at $\Delta T=100$ K	I_{max}	Article No.	Nm/A	$J_{without\ brake}$	$J_{with\ brake}$		$m_{without\ brake}$	$m_{with\ brake}$
rpm	kW (hp)	Nm	Nm	Nm	A	A			kg cm ²	kg cm ²		kg	kg

SIMOTICS S-1FL2 Medium Inertia servomotors – For dynamic and smooth operational performance

Shaft height 30 – Rated speed n_N 3000 rpm – Line voltage 200 ... 240 V 1 AC / 3 AC

6500	0.20 (0.27)	0.64	0.64	2.24	1.33	4.8	1FL2203-2AG ■ ■ - ■ ■ C 0	0.48	0.18	0.21	30x	0.76	1.11
6500	0.40 (0.54)	1.27	1.27	4.45	2.4	8.7	1FL2203-4AG ■ ■ - ■ ■ C 0	0.53	0.35	0.38		1.11	1.46

Shaft height 30 – Rated speed n_N 3000 rpm – Line voltage 380 ... 480 V 3 AC

6500	0.20 (0.27)	0.64	0.64	2.24	1.3	4.8	1FL2203-2AF ■ ■ - ■ ■ C 0	0.49	0.18	0.21	30x	0.77	1.12
6500	0.40 (0.54)	1.27	1.27	4.45	1.3	4.8	1FL2203-4AF ■ ■ - ■ ■ C 0	0.98	0.35	0.38		1.09	1.44

Shaft height 40 – Rated speed n_N 3000 rpm – Line voltage 200 ... 240 V 1 AC / 3 AC

6500	0.75 (1.02)	2.4	2.4	7.5	4.4	14.2	1FL2204-2AG ■ ■ - ■ ■ C 0	0.55	1.23	1.31	15x	2.6	3.4
6500	1.00 (1.36)	3.2	3.2	11.3	4.4	16	1FL2204-4AG ■ ■ - ■ ■ C 0	0.73	1.61	1.69		3.1	3.9

Shaft height 40 – Rated speed n_N 3000 rpm – Line voltage 380 ... 480 V 3 AC

6500	0.75 (1.02)	2.4	2.4	7.5	2.25	7.1	1FL2204-2AF ■ ■ - ■ ■ C 0	1.07	1.23	1.31	15x	2.6	3.4
6500	1.00 (1.36)	3.2	3.2	10	3	9.9	1FL2204-4AF ■ ■ - ■ ■ C 0	1.07	1.61	1.69		3.1	3.9

Shaft height 48 – Rated speed n_N 3000 rpm – Line voltage 380 ... 480 V 3 AC

6000	0.94 (1.36)	3.6	3	11.5	2.5	9.5	1FL2205-2AF ■ 1 - ■ ■ B 0	1.24	3.15	4.03	15x	3.6	4.7
6000	1.45 (2.04)	6	4.6	19.3	3.75	15.1	1FL2205-4AF ■ 1 - ■ ■ B 0	1.28	5.1	5.98		5	6.1

Brake

Without
Holding brake0
1

Degree of protection

IP54
IP65 (with shaft sealing ring)0
1

Shaft extension, feather key

Plain shaft
Shaft with feather key (half-key balancing)0
1

Encoder

Absolute encoder 17-bit singleturn
Absolute encoder 21-bit singleturn
Absolute encoder 21-bit singleturn + 12-bit multiturnH
S
M

Connection technology

Metal circular connector
Metal hybrid connectorB
CDetailed information on SINAMICS S200 is available on the internet at: www.siemens.com/sinamics-s200In addition, the Siemens Product Configurator can be used on the internet: www.siemens.com/sinamics-s200/configuration

¹⁾ Rated torque, rated power and maximum torque listed in the table above allow for a production tolerance of 10 %.

²⁾ Motor weight with absolute encoder 17-bit singleturn.

6SL3255-0AA00-5AA0



SINAMICS S200 servo drive system with SIMOTICS S-1FL2 Medium Inertia servomotors

1

MOTION-CONNECT connection systems (continued) – Further info in section "MOTION-CONNECT 350 and 380 connection systems".

Pre-assembled dual cables for communication		Connectors				
SINAMICS S200 – Brake on the 1FL2 servomotor with holding brake		Drive end (DE) direction	Non drive end (NDE) direction	Motor side		
No. of cores x cross-section mm ²	Article No.	for hybrid connection Article No.	for hybrid connection Article No.	for power connection Article No.	for absolute encoder Article No.	for brake Article No.

MOTION-CONNECT connection systems (continued)

-	-	6FX2003-3HD00	6FX2003-3HN00	-	-	-
-	-	6FX2003-3HD00	6FX2003-3HN00	-	-	-
-	-	6FX2003-3HD00	6FX2003-3HN00	-	-	-
-	-	6FX2003-3HD00	6FX2003-3HN00	-	-	-
-	-	-	-	6FX2003-0LL63	6FX2003-0DB63	- (in power connector)

MOTION-CONNECT connectors for SINAMICS S200 servo converters

Crimp contacts "power and PE" (2000 pieces per reel) for hybrid connection	Crimp contacts "signal" (2000 pieces per reel) for hybrid connection	Connectors converter side		
		for power connection	IX signal connector, C-code, for absolute encoder	for brake
6FX2003-7HP00	6FX2003-7HS00	-	6FX2003-0DE61	-

System overview

Clicking to SiePortal

6SL3255-0AA00-5AA0



SINAMICS S200 servo drive system with SIMOTICS S-1FL2 High Inertia servomotors

Selection and ordering data

SIMOTICS S-1FL2 servomotors – Further info in section "SIMOTICS S-1FL2 servomotors".

Max. speed	Rated power ¹⁾	Static torque	Rated torque ¹⁾	Max. torque ¹⁾	Rated current	Max. current	Article No.	Torque constant	Moment of inertia of rotor	Recommended load to motor inertia ratio, max.	Weight ²⁾	
n_{max}	P_N at $\Delta T=100\text{ K}$	M_0 at $\Delta T=100\text{ K}$	M_N at $\Delta T=100\text{ K}$	M_{max}	I_N at $\Delta T=100\text{ K}$	I_{max}			$J_{without\ brake}$	$J_{with\ brake}$	$m_{without\ brake}$	$m_{with\ brake}$
rpm	kW (hp)	Nm	Nm	Nm	A	A		Nm/A	kg cm ²	kg cm ²	kg	kg

SIMOTICS S-1FL2 High Inertia servomotors – For smooth operational performance

Shaft height 45 – Rated speed n_N 3000 rpm – Line voltage 380 ... 480 V 3 AC

4000	0.40 (0.54)	1.45	1.27	4.445	1.2	4.2	1FL2304-2AF ■ 1 - ■ ■ B 0	1.12	2.69	3.05	10×	3.5	4.9
4000	0.75 (1.02)	3.02	2.39	8.365	2.1	7.3	1FL2304-4AF ■ 1 - ■ ■ B 0	1.21	5.18	5.54		5.4	6.8

Shaft height 65 – Rated speed n_N 2000 rpm – Line voltage 380 ... 480 V 3 AC

3000	0.75 (1.02)	3.7	3.58	12	2.5	8.4	1FL2306-1AC ■ 1 - ■ ■ B 0	1.48	7.962	9.57	10×	5.9	8.9
3000	1.00 (1.36)	5	4.78	17	3	10.7	1FL2306-2AC ■ 1 - ■ ■ B 0	1.67	11.65	13.26	5×	7.3	10.3
3000	1.50 (2.04)	8	7.16	22	4.6	14.1	1FL2306-4AC ■ 1 - ■ ■ B 0	1.63	15.287	16.9		8.6	11.6
3000	1.75 (2.38)	8.8	8.4	30	5.3	19	1FL2306-6AC ■ 1 - ■ ■ B 0	1.66	22.612	24.22		11.1	14.1
3000	2.00 (2.72)	13.3	9.6	33.425	5.9	20.7	1FL2306-7AC ■ 1 - ■ ■ B 0	1.71	29.938	31.55		13.7	16.7

Shaft height 90 – Rated speed n_N 2000 rpm – Line voltage 380 ... 480 V 3 AC

3000	2.50 (3.40)	12.6	11.9	37.5	7.8	25.2	1FL2310-0AC ■ 1 - ■ ■ B 0	1.62	47.409	56.78	5×	15.4	21.4
3000	3.50 (4.76)	18.1	16.7	55	11	36.2	1FL2310-2AC ■ 1 - ■ ■ B 0	1.65	69.095	78.47		19.4	25.4
2500	5.00 (6.80)	25.2	23.9	70	12.6	36.9	1FL2310-4AC ■ 1 - ■ ■ B 0	2	90.827	100.2		23.7	29.7
2000	7.00 (9.52)	35.2	33.4	90	13.2	35.6	1FL2310-6AC ■ 1 - ■ ■ B 0	2.67	134.292	143.66		31.9	37.9

Brake

Without
Holding brake0
1

Degree of protection

IP54
IP65 (with shaft sealing ring)0
1

Shaft extension, feather key

Plain shaft
Shaft with feather key (half-key balancing)0
1

Encoder

Absolute encoder 17-bit singleturn
Absolute encoder 21-bit singleturn
Absolute encoder 21-bit singleturn + 12-bit multiturnH
S
M

Connection technology

Metal circular connector
Metal hybrid connectorB
CDetailed information on SINAMICS S200 is available on the internet at: www.siemens.com/sinamics-s200In addition, the Siemens Product Configurator can be used on the internet: www.siemens.com/sinamics-s200/configuration

¹⁾ Rated torque, rated power and maximum torque listed in the table above allow for a production tolerance of 10 %.

²⁾ Motor weight with absolute encoder 17-bit singleturn.

Clicking to SiePortal

System overview

6SL3255-0AA00-5AA0



SINAMICS S200 servo drive system with SIMOTICS S-1FL2 High Inertia servomotors

1

SINAMICS S200 servo converters Further info in section "SINAMICS S200 servo converters".		Line filter			Recommended standard fuse			Recommended circuit breaker		
Max. motor power		Frame size	With one of the recommended line filters, IEC 61800-3 category C2 can be reached in combination with SINAMICS S200 for motor cable lengths up to 30 m (98.5 ft).			More information at www.siemens.com/sinamics-s200/ocpd		IEC/UL/cUL-compliant		
kW (hp) Article No.						Line voltage	I_N		/	3NA3
		V	A	Article No.	A	Article No.	A	Class	Article No.	
SINAMICS S200 and SINAMICS S200 Basic servo converters										
Line voltage 380 ... 480 V 3 AC										
0.40 (0.54)	6SL5 5 10-1BE10-4A 0	FSA	3 AC 380 ... 480	5	6SL5550-0XE20-5CA0	4	3NA3804	3	J	3RV2011-1DA10
0.75 (1.02)	6SL5 5 10-1BE10-8A 0	FSB				10	3NA3803	10		3RV2011-1EA10
Line voltage 380 ... 480 V 3 AC										
0.75 (1.02)	6SL5 5 10-1BE10-8A 0	FSB	3 AC 380 ... 480	5	6SL5550-0XE20-5CA0	10	3NA3803	10	J	3RV2011-1EA10
1.00 (1.36)	6SL5 5 10-1BE11-0A 0									3RV2011-1FA10
1.75 (2.38)	6SL5 5 10-1BE11-5A 0	FSC	3 AC 380 ... 480	12	6SL5550-0XE21-2CA0	16	3NA3805	15		3RV2011-4AA10
2.50 (3.40)	6SL5 5 10-1BE12-5A 0									3RV2011-4AA10
Line voltage 380 ... 480 V 3 AC										
2.50 (3.40)	6SL5 5 10-1BE12-5A 0	FSC	3 AC 380 ... 480	12	6SL5550-0XE21-2CA0	16	3NA3805	20	J	3RV2011-4AA10
3.50 (4.76)	6SL5 5 10-1BE13-5A 0	FSD	3 AC 380 ... 480	20	6SL5550-0XE22-0CA0	20	3NA3807	25		3RV2021-4BA10
5.00 (6.80)	6SL5 5 10-1BE15-0A 0									3RV2021-4BA10
7.00 (9.52)	6SL5 5 10-1BE17-0A 0					25	3NA3810			3RV2021-4DA10
Servo converter										
SINAMICS S200	5									
SINAMICS S200 Basic	6									
Version										
Pulse Train Input (PTI) ¹⁾	A									
PROFINET (PN)	F									

1) Available soon.

System overview

Clicking to SiePortal

6SL3255-0AA00-5AA0



SINAMICS S200 servo drive system with SIMOTICS S-1FL2 High Inertia servomotors

Selection and ordering data

SIMOTICS S-1FL2 servomotors – Further info in section "SIMOTICS S-1FL2 servomotors".

Max. speed	Rated power ¹⁾	Static torque	Rated torque ¹⁾	Max. torque ¹⁾	Rated current	Max. current		Torque constant	Moment of inertia of rotor		Recommended load to motor inertia ratio, max.	Weight ²⁾	
n_{max}	P_N at $\Delta T=100\text{ K}$	M_0 at $\Delta T=100\text{ K}$	M_N at $\Delta T=100\text{ K}$	M_{max}	I_N at $\Delta T=100\text{ K}$	I_{max}	Article No.	Nm/A	$J_{without\ brake}$	$J_{with\ brake}$		$m_{without\ brake}$	$m_{with\ brake}$
rpm	kW (hp)	Nm	Nm	Nm	A	A			kg cm ²	kg cm ²		kg	kg

SIMOTICS S-1FL2 High Inertia servomotors – For smooth operational performance

Shaft height 45 – Rated speed n_N 3000 rpm – Line voltage 380 ... 480 V 3 AC

4000	0.40 (0.54)	1.45	1.27	4.445	1.2	4.2	1FL2304-2AF ■ 1 - ■ ■ B 0	1.12	2.69	3.05	10x	3.5	4.9
4000	0.75 (1.02)	3.02	2.39	8.365	2.1	7.3	1FL2304-4AF ■ 1 - ■ ■ B 0	1.21	5.18	5.54		5.4	6.8

Shaft height 65 – Rated speed n_N 2000 rpm – Line voltage 380 ... 480 V 3 AC

3000	0.75 (1.02)	3.7	3.58	12	2.5	8.4	1FL2306-1AC ■ 1 - ■ ■ B 0	1.48	7.962	9.57	10x	5.9	8.9
3000	1.00 (1.36)	5	4.78	17	3	10.7	1FL2306-2AC ■ 1 - ■ ■ B 0	1.67	11.65	13.26	5x	7.3	10.3
3000	1.50 (2.04)	8	7.16	22	4.6	14.1	1FL2306-4AC ■ 1 - ■ ■ B 0	1.63	15.287	16.9		8.6	11.6
3000	1.75 (2.38)	8.8	8.4	30	5.3	19	1FL2306-6AC ■ 1 - ■ ■ B 0	1.66	22.612	24.22		11.1	14.1
3000	2.00 (2.72)	13.3	9.6	33.425	5.9	20.7	1FL2306-7AC ■ 1 - ■ ■ B 0	1.71	29.938	31.55		13.7	16.7

Shaft height 90 – Rated speed n_N 2000 rpm – Line voltage 380 ... 480 V 3 AC

3000	2.50 (3.40)	12.6	11.9	37.5	7.8	25.2	1FL2310-0AC ■ 1 - ■ ■ B 0	1.62	47.409	56.78	5x	15.4	21.4
3000	3.50 (4.76)	18.1	16.7	55	11	36.2	1FL2310-2AC ■ 1 - ■ ■ B 0	1.65	69.095	78.47		19.4	25.4
2500	5.00 (6.80)	25.2	23.9	70	12.6	36.9	1FL2310-4AC ■ 1 - ■ ■ B 0	2	90.827	100.2		23.7	29.7
2000	7.00 (9.52)	35.2	33.4	90	13.2	35.6	1FL2310-6AC ■ 1 - ■ ■ B 0	2.67	134.292	143.66		31.9	37.9

Brake

Without
Holding brake0
1

Degree of protection

IP54
IP65 (with shaft sealing ring)0
1

Shaft extension, feather key

Plain shaft
Shaft with feather key (half-key balancing)0
1

Encoder

Absolute encoder 17-bit singleturn
Absolute encoder 21-bit singleturn
Absolute encoder 21-bit singleturn + 12-bit multiturnH
S
M

Connection technology

Metal circular connector
Metal hybrid connectorB
CDetailed information on SINAMICS S200 is available on the internet at: www.siemens.com/sinamics-s200In addition, the Siemens Product Configurator can be used on the internet: www.siemens.com/sinamics-s200/configuration

¹⁾ Rated torque, rated power and maximum torque listed in the table above allow for a production tolerance of 10 %.

²⁾ Motor weight with absolute encoder 17-bit singleturn.

6SL3255-0AA00-5AA0



SINAMICS S200 servo drive system with SIMOTICS S-1FL2 High Inertia servomotors

1

MOTION-CONNECT connection systems – Further info in section "MOTION-CONNECT 350 and 380 connection systems".						
Pre-assembled dual cables for power and communication		Pre-assembled power cables		Pre-assembled dual cables for communication		
No. of cores × cross-section mm ²	Article No.	No. of cores × cross-section mm ²	Article No.	No. of cores × cross-section mm ²	Article No.	
MOTION-CONNECT connection systems						
–	–	4 × 0.75	6FX3 02-5 C L01-1 0	3 × 2 × 0.25 ¹⁾	6FX3 02-2XB12-1 0	
–	–	4 × 0.75	6FX3 02-5 C L01-1 0	3 × 2 × 0.25 ¹⁾	6FX3 02-2XB12-1 0	
–	–	4 × 1.5	6FX3 02-5 C L02-1 0	3 × 2 × 0.25 ¹⁾	6FX3 02-2XB12-1 0	
–	–	4 × 2.5	6FX3 02-5 C L12-1 0			
Connection system			5		5	
MOTION-CONNECT 350			8		8	
MOTION-CONNECT 380						
Brake cores						
Without				C		
Holding brake				D		
Length						
3 m				A	D	A
5 m				A	F	A
7 m				A	H	A
10 m				B	A	B
15 m				B	F	B
20 m				C	A	C
30 m				D	A	D

¹⁾ No. of cores × cross-section for encoder cable in mm² for:
 Length <20 m: 3 × 2 × 0.25
 Length ≥ 20 m: 2 × 2 × 0.25 + 2 × 0.38

System overview

[Clicking to SiePortal](#)

6SL3255-0AA00-5AA0



1

SINAMICS S200 servo drive system with SIMOTICS S-1FL2 High Inertia servomotors

Selection and ordering data

SIMOTICS S-1FL2 servomotors – Further info in section "SIMOTICS S-1FL2 servomotors".

Max. speed	Rated power ¹⁾	Static torque	Rated torque ¹⁾	Max. torque ¹⁾	Rated current	Max. current	Article No.	Torque constant	Moment of inertia of rotor	Recommended load to motor inertia ratio, max.	Weight ²⁾	
n_{max}	P_N at $\Delta T=100\text{ K}$	M_0 at $\Delta T=100\text{ K}$	M_N at $\Delta T=100\text{ K}$	M_{max}	I_N at $\Delta T=100\text{ K}$	I_{max}			$J_{without\ brake}$	$J_{with\ brake}$	$m_{without\ brake}$	$m_{with\ brake}$
rpm	kW (hp)	Nm	Nm	Nm	A	A		Nm/A	kg cm ²	kg cm ²	kg	kg

SIMOTICS S-1FL2 High Inertia servomotors – For smooth operational performance

Shaft height 45 – Rated speed n_N 3000 rpm – Line voltage 380 ... 480 V 3 AC

4000	0.40 (0.54)	1.45	1.27	4.445	1.2	4.2	1FL2304-2AF ■ 1 - ■ ■ B 0	1.12	2.69	3.05	10x	3.5	4.9
4000	0.75 (1.02)	3.02	2.39	8.365	2.1	7.3	1FL2304-4AF ■ 1 - ■ ■ B 0	1.21	5.18	5.54		5.4	6.8

Shaft height 65 – Rated speed n_N 2000 rpm – Line voltage 380 ... 480 V 3 AC

3000	0.75 (1.02)	3.7	3.58	12	2.5	8.4	1FL2306-1AC ■ 1 - ■ ■ B 0	1.48	7.962	9.57	10x	5.9	8.9
3000	1.00 (1.36)	5	4.78	17	3	10.7	1FL2306-2AC ■ 1 - ■ ■ B 0	1.67	11.65	13.26	5x	7.3	10.3
3000	1.50 (2.04)	8	7.16	22	4.6	14.1	1FL2306-4AC ■ 1 - ■ ■ B 0	1.63	15.287	16.9		8.6	11.6
3000	1.75 (2.38)	8.8	8.4	30	5.3	19	1FL2306-6AC ■ 1 - ■ ■ B 0	1.66	22.612	24.22		11.1	14.1
3000	2 (2.72)	13.3	9.6	33.425	5.9	20.7	1FL2306-7AC ■ 1 - ■ ■ B 0	1.71	29.938	31.55		13.7	16.7

Shaft height 90 – Rated speed n_N 2000 rpm – Line voltage 380 ... 480 V 3 AC

3000	2.50 (3.40)	12.6	11.9	37.5	7.8	25.2	1FL2310-0AC ■ 1 - ■ ■ B 0	1.62	47.409	56.78	5x	15.4	21.4
3000	3.50 (4.76)	18.1	16.7	55	11	36.2	1FL2310-2AC ■ 1 - ■ ■ B 0	1.65	69.095	78.47		19.4	25.4
2500	5.00 (6.80)	25.2	23.9	70	12.6	36.9	1FL2310-4AC ■ 1 - ■ ■ B 0	2	90.827	100.2		23.7	29.7
2000	7.00 (9.52)	35.2	33.4	90	13.2	35.6	1FL2310-6AC ■ 1 - ■ ■ B 0	2.67	134.292	143.66		31.9	37.9

Brake

Without
Holding brake

0
1

Degree of protection

IP54
IP65 (with shaft sealing ring)

0
1

Shaft extension, feather key

Plain shaft
Shaft with feather key (half-key balancing)

0
1

Encoder

Absolute encoder 17-bit singleturn
Absolute encoder 21-bit singleturn
Absolute encoder 21-bit singleturn + 12-bit multeturn

H
S
M

Connection technology

Metal circular connector
Metal hybrid connector

B
C

Detailed information on SINAMICS S200 is available on the internet at: www.siemens.com/sinamics-s200

In addition, the Siemens Product Configurator can be used on the internet: www.siemens.com/sinamics-s200/configuration

¹⁾ Rated torque, rated power and maximum torque listed in the table above allow for a production tolerance of 10 %.

²⁾ Motor weight with absolute encoder 17-bit singleturn.

6SL3255-0AA00-5AA0



SINAMICS S200 servo drive system with SIMOTICS S-1FL2 High Inertia servomotors

1

MOTION-CONNECT connection systems (continued) – Further info in section "MOTION-CONNECT 350 and 380 connection systems".						
Pre-assembled dual cables for communication		Connectors				
SINAMICS S200 – Brake on the 1FL2 servomotor with holding brake		Drive end (DE) direction	Non drive end (NDE) direction	Motor side		
No. of cores x cross-section mm ²	Article No.	for hybrid connection Article No.	for hybrid connection Article No.	for power connection Article No.	for absolute encoder Article No.	for brake Article No.

MOTION-CONNECT connection systems (continued)

2 x 0.75	6FX3 02-5BL03-1 0	–	–	6FX2003-0LL13	6FX2003-0DB13	6FX2003-0LL53
2 x 0.75	6FX3 02-5BL03-1 0	–	–	6FX2003-0LL13	6FX2003-0DB13	6FX2003-0LL53
2 x 0.75	6FX3 02-5BL03-1 0	–	–	6FX2003-0LL13	6FX2003-0DB13	6FX2003-0LL53

Connection system	
MOTION-CONNECT 350	5
MOTION-CONNECT 380	8

Length	
3 m	A D
5 m	A F
7 m	A H
10 m	B A
15 m	B F
20 m	C A
30 m	D A

MOTION-CONNECT connectors for SINAMICS S200 servo converters

Connectors converter side		
for power connection	IX signal connector, C-code, for absolute encoder	for brake
–	6FX2003-0DE61	–



SINAMICS S200 servo drive system

1

Accessories

Accessories for SINAMICS S200 Basic and SINAMICS S200 servo converters, PROFINET version

Description	Article No.
SINAMICS SD card 8 GB Parameter assignments, firmware and licenses for a converter can be stored on the memory card.	
• Empty	6SL5970-0AA00-0AA0
• With firmware V6.2	6SL5570-0GC00-0AA0
PROFINET I/O connector 20-pin	6SL3260-2MA00-0VA0
PROFINET I/O cable with 20-pin MDR connector, length: 1 m (3.28 ft)	6SL5562-1XX00-0AC0
PROFINET I/O adapter ¹⁾ for 20-pin MDR connector	6SL5562-1XX00-0AD0
Pre-assembled PROFINET cable with two RJ45 180° plugs, length: 1 m (3.28 ft)	6XV1871-5BH10
RJ45 data plug-in connector with 180° (straight) cable outlet	6GK1901-1BB10-2AA0
Standard PROFINET cable 4-core, sold by the meter, not assembled	6XV1840-2AH10
PROFINET patch cable For the networking of concatenated converters Industrial Ethernet TP cord, CAT 6 A, twisted pair line 4 × 2 cores, pre-assembled with two RJ45 connectors	
• 0.3 m (0.98 ft)	6XV1870-3QE30
• 0.5 m (1.64 ft)	6XV1870-3QE50

For further information about PROFINET cables refer on the internet at:

www.siemens.com/simatic-net

Recommended SIMATIC S7 controller

More information about SIMATIC S7-1500 and SIMATIC S7-1500 T-CPU controllers is available in Catalog ST 70 and on the internet at:

www.siemens.com/simatic-s7-1500

Spare parts for SINAMICS S200 Basic and SINAMICS S200 servo converters, PROFINET version

Description	Article No.
Shield connection kit including several shield plates and fixing screws	6SL5566-0AB00-0AA0
Terminal kits	
• for SINAMICS S200	6SL5568-0XX00-0AA0
• for SINAMICS S200 Basic	6SL5668-0XX00-0AA0
Replacement fans	
• for SINAMICS S200, 400 V version, FSC	6SL5566-0CE00-0AA0
• for SINAMICS S200, 400 V version, FSD	6SL5566-0DE00-0AA0

Starter kit (available soon)

Description	Article No.
SINAMICS S200 PN starter kit	6SL5990-0AE50-0AA0
Scope of delivery:	
• SINAMICS S200 servo converter, PROFINET version, 200 V, 400 W	
• SIMOTICS S-1FL2 Low Inertia servomotor, shaft height 30, 400 W, IP65 degree of protection, without holding brake, shaft with feather key, with absolute encoder 21-bit singleturn	
• Pre-assembled dual motor connection cable, drive end, 3 m (9.84 ft)	
• Pre-assembled PROFINET I/O cable, 1 m (3.28 ft)	
The delivery quantity is limited to three units per customer.	

Training case (available soon)

Description	Article No.
SINAMICS S200 training case	available soon
Scope of delivery:	
• 2 × SINAMICS S200 servo converter, PROFINET version, 200 V, 100 W	
• 1 × SIMOTICS S-1FL2 Low Inertia servomotor, absolute encoder 21-bit singleturn	
• 1 × SIMOTICS S-1FL2 Low Inertia servomotor, absolute encoder 21-bit singleturn + 12-bit multiturn	
• 2 × Pre-assembled dual motor connection cable	
• Rail, prepared for installation of a controller, e.g. SIMATIC S7-1500 (controller not included in scope of delivery)	
The SINAMICS S200 training case is supplied as a trolley with a hood.	

More information

Identification link according to IEC 61406 for SINAMICS S200

The ID link contains the article and serial number of the product. As a QR code, it replaces the previous data matrix code on the nameplate and takes you with the URL directly to a product information page on the internet with access to the technical documentation, data sheet, certificates, FAQs, product notifications, and catalogs. Paper package inserts become superfluous since the information is available electronically directly via the QR code, even years later. In this way, we are making a valuable contribution to the preservation of our environment. You don't need an additional app. Simply scan the QR code with your smartphone or tablet. According to IEC 61406, the QR code of an ID link is marked with a frame and a triangle at the bottom right.

With their globally unique identifiers, Siemens products are ready for Industry 4.0.

The ID serves as a connection to the administration shell with which modules of the digital twin can be provided.

¹⁾ Available soon.

Further documentation, such as the operating instructions, is available free on the internet at:

www.siemens.com/sinamics-s200/documentation

Detailed information on the SINAMICS S200 drive system, including the latest technical documentation (brochures, tutorials, dimensional drawings, certificates, manuals and operating instructions), is available on the internet at:

www.siemens.com/sinamics-s200

and is also available via the Siemens Product Configurator on the internet.

The Siemens Product Configurator can be found in SiePortal at the following address:

www.siemens.com/sinamics-s200/configuration

Selection and ordering data

Description	Article No.
SINAMICS S200 PN starter kit (Available soon)	6SL5990-0AE50-0AA0
Scope of delivery:	
<ul style="list-style-type: none">• SINAMICS S200 servo converter, PROFINET version, 200 V, 400 W• SIMOTICS S-1FL2 Low Inertia servomotor, shaft height 30, 400 W, IP65 degree of protection, without holding brake, shaft with feather key, with absolute encoder 21-bit singleturn• Pre-assembled dual motor connection cable, drive end, 3 m (9.84 ft)• Pre-assembled PROFINET I/O cable, 1 m (3.28 ft)	

System overview

Recommended SIMATIC S7 controller

Selection and ordering data

Recommended controller for SINAMICS S200 PROFINET (PN) version

Version	Integrated interfaces	PROFINET	PROFIBUS DP	CPU Processing times for bit operations	Max. number of axes	Work memory	CPU	Article No.
SIMATIC S7-1200 Basic Controller for SINAMICS S200 PROFINET (PN) version								
Standard CPUs	1 × PN IO	–	–	85 ns	2	50 KB	CPU 1211C DC/DC/DC	6ES7211-1AE40-0XB0
		–	–	85 ns	2	75 KB	CPU 1212C DC/DC/DC	6ES7212-1AE40-0XB0
		–	–	85 ns	2	100 KB	CPU 1214C DC/DC/DC	6ES7214-1AG40-0XB0
	1 × PN IO (2-port switch)	–	–	85 ns	2	125 KB	CPU 1215C DC/DC/DC	6ES7215-1AG40-0XB0
		–	–	85 ns	2	150 KB	CPU 1217C DC/DC/DC	6ES7217-1AG40-0XB0
SIMATIC S7-1500 Advanced Controller for SINAMICS S200 PROFINET (PN) version								
Standard CPUs	1 × PN IO IRT (2-port switch)	–	–	60 ns	10	150 KB	CPU 1511-1 PN	6ES7511-1AK02-0AB0
		–	–	40 ns	10	300 KB	CPU 1513-1 PN	6ES7513-1AL02-0AB0
		1 × PN	–	30 ns	30	500 KB	CPU 1515-2 PN	6ES7515-2AM02-0AB0
		1 × PN	1 × DP	10 ns	30	1 MB	CPU 1516-3 PN/DP	6ES7516-3AN02-0AB0
		1 × PN	1 × DP	2 ns	96	2 MB	CPU 1517-3 PN/DP	6ES7517-3AP00-0AB0
		2 × PN	1 × DP	1 ns	128	4 MB	CPU 1518-4 PN/DP	6ES7518-4AP00-0AB0
Compact CPUs	1 × PN IO IRT (2-port switch)	–	–	60 ns	10	175 KB	CPU 1511C-1 PN	6ES7511-1CK01-0AB0
		–	–	48 ns	10	250 KB	CPU 1512C-1 PN	6ES7512-1CK01-0AB0
Technology CPUs	1 × PN IO IRT (2-port switch)	–	–	60 ns	10	225 KB	CPU 1511T-1 PN	6ES7511-1TK01-0AB0
		1 × PN	–	30 ns	30	750 KB	CPU 1515T-2 PN	6ES7515-2TM01-0AB0
		1 × PN	1 × DP	10 ns	80	1.5 MB	CPU 1516T-3 PN/DP	6ES7516-3TN00-0AB0
		1 × PN	1 × DP	2 ns	128	3 MB	CPU 1517T-3 PN/DP	6ES7517-3TP00-0AB0
		2 × PN	1 × DP	1 ns	192	9 MB	CPU 1518T-4 PN/DP	6ES7518-4TP00-0AB0
Fail-safe CPUs	1 × PN IO IRT (2-port switch)	–	–	60 ns	10	225 KB	CPU 1511F-1 PN	6ES7511-1FK02-0AB0
		–	–	40 ns	10	450 KB	CPU 1513F-1 PN	6ES7513-1FL02-0AB0
		1 × PN	–	30 ns	30	750 KB	CPU 1515F-2 PN	6ES7515-2FM02-0AB0
		1 × PN	1 × DP	10 ns	30	1.5 MB	CPU 1516F-3 PN/DP	6ES7516-3FN02-0AB0
		1 × PN	1 × DP	2 ns	96	3 MB	CPU 1517F-3 PN/DP	6ES7517-3FP00-0AB0
		2 × PN	1 × DP	1 ns	128	6 MB	CPU 1518F-4 PN/DP	6ES7518-4FP00-0AB0
Fail-safe Technology CPUs	1 × PN IO IRT (2-port switch)	–	–	60 ns	10	225 KB	CPU 1511TF-1 PN	6ES7511-1UK01-0AB0
		1 × PN	–	30 ns	14	750 KB	CPU 1515TF-2 PN	6ES7515-2UM01-0AB0
		1 × PN	1 × DP	10 ns	80	1.5 MB	CPU 1516TF-3 PN/DP	6ES7516-3UN00-0AB0
		1 × PN	1 × DP	2 ns	128	3 MB	CPU 1517TF-3 PN/DP	6ES7517-3UP00-0AB0
		2 × PN	1 × DP	1 ns	192	9 MB	CPU 1518TF-4 PN/DP	6ES7518-4UP00-0AB0

For SINAMICS S200 PROFINET (PN) version, the AC/DC/RLY and DC/DC/RLY versions of SIMATIC S7-1200 are also possible (CPU 1211C, CPU 1212C, CPU 1214C and CPU 1215C).

SINAMICS S200 as a PROFINET I/O device with PROFIdrive supports technology objects and function blocks of SIMATIC S7-1200, SIMATIC S7-1500 and SIMATIC S7-1500 Technology CPU for speed and positioning control.

For further information about SIMATIC controllers please refer to Catalog ST 70 or to web page: www.siemens.com/simatic-controller

SINAMICS S200 servo converters

**2/2 SINAMICS S200 Basic servo converters**

- 2/2 Overview
- 2/3 Design
- 2/4 Function
- 2/5 Integration
- 2/6 Selection and ordering data
- 2/7 Technical specifications
- 2/9 Dimensional drawings
- 2/10 More info

2/11 SINAMICS S200 servo converters

- 2/11 Overview
- 2/12 Design
- 2/13 Function
- 2/14 Integration
- 2/15 Selection and ordering data
- 2/17 Technical specifications
- 2/20 Dimensional drawings
- 2/21 More info

2/22 Line-side components

- 2/22 Line filters
- 2/22 Overview
- 2/22 Selection and ordering data
- 2/22 Technical specifications
- 2/23 More info
- 2/24 Recommended line-side overcurrent protection devices
- 2/24 Overview
- 2/24 Selection and ordering data

2/25 DC link components

- 2/25 External braking resistors
- 2/25 Overview

2/26 Connecting cables for SIMATIC S7 controllers

- 2/26 Selection and ordering data

2/27 Supplementary system components

- 2/27 Memory cards

2/26 Spare parts

- 2/28 Shield connection kit
- 2/28 Terminal kits
- 2/28 Replacement fans

For **selection and ordering data** please also refer to section "System overview" "SINAMICS S200 servo drive system" from page 1/14.

Detailed technical information on SINAMICS S200 is available on the internet at:
www.siemens.com/sinamics-s200/documentation

In addition, the Siemens Product Configurator can be used on the internet at the following address:
www.siemens.com/sinamics-s200/configuration

SINAMICS S200 servo converters

SINAMICS S200 Basic servo converters

Overview

SINAMICS S200 Basic servo converters



SINAMICS S200 Basic servo converters, 200 ... 240 V 1 AC / 3 AC, PROFINET, frame sizes FSA, FSB and FSC

The SINAMICS S200 servo converters consist of a basic version and a standard version with pulse train input position control (PTI) ¹⁾ or PROFINET RT/IRT (PN) to meet various needs of applications and works perfectly together with SIMATIC controllers.

- SINAMICS S200 Basic servo converters, power range 0.1 to 1 kW at 200 ... 240 V 1 AC / 3 AC
- SINAMICS S200 servo converters, power range 0.1 to 1 kW at 200 ... 240 V 1 AC / 3 AC and 0.2 to 7 kW at 380 ... 480 V 3 AC

¹⁾ Available soon.

Design

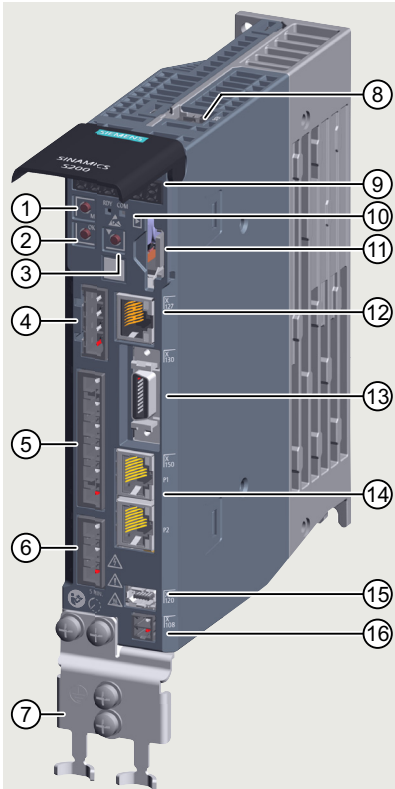

- | | |
|---|--|
| ① M button | ⑨ 6-digit display |
| ② OK button | ⑩ LED status indicators |
| ③ DOWN button | ⑪ Memory card slot |
| ④ 24 V DC power supply - X124 | ⑫ Service interface (Ethernet) - X127 |
| ⑤ Mains and braking resistor interface - X1 | ⑬ Control/status inputs and outputs - X130 |
| ⑥ Motor power interface - X2 | ⑭ PROFINET interface - X150 |
| ⑦ Shield plate | ⑮ Encoder interface - X120 |
| ⑧ STO interface - X131 ¹⁾ | ⑯ Motor holding brake interface - X108 ¹⁾ |

¹⁾ The interfaces X131 and X108 are only available on the SINAMICS S200 converters, not on the SINAMICS S200 Basic converters.

Interface overview SINAMICS S200 Basic servo converters, PROFINET version

G_DD211_EN_00704

SINAMICS S200 servo converters

SINAMICS S200 Basic servo converters

Function

Closed-loop control	Servo control with DSC
Control functions	<ul style="list-style-type: none"> Speed control with encoder Dynamic Servo Control (DSC) Basic positioner (EPos) Ramp-function generator Torque setpoint limitation Current controller and current controller adaptation suitably adjusted for SIMOTICS S-1FL2 servomotors One Button Tuning with moment of inertia estimator and reference model Local measuring probe Simple brake control Direction reversal without changing the setpoint channel Travel to fixed stop Vertical axis Speed controller adaptation Thermal monitoring for power unit and servomotor
Protection functions	<ul style="list-style-type: none"> Undervoltage DC link voltage Overvoltage DC link voltage Overcurrent power unit Overcurrent motor Overload power unit (I^2t) Short-circuit Ground fault Temperature rise servomotor Temperature rise power unit
Safety Integrated	–
Commissioning	<ul style="list-style-type: none"> Identification of the SIMOTICS S-1FL2 servomotors via the electronic type plate Automatic controller optimization

SINAMICS S200 servo converters

SINAMICS S200 Basic servo converters

Integration

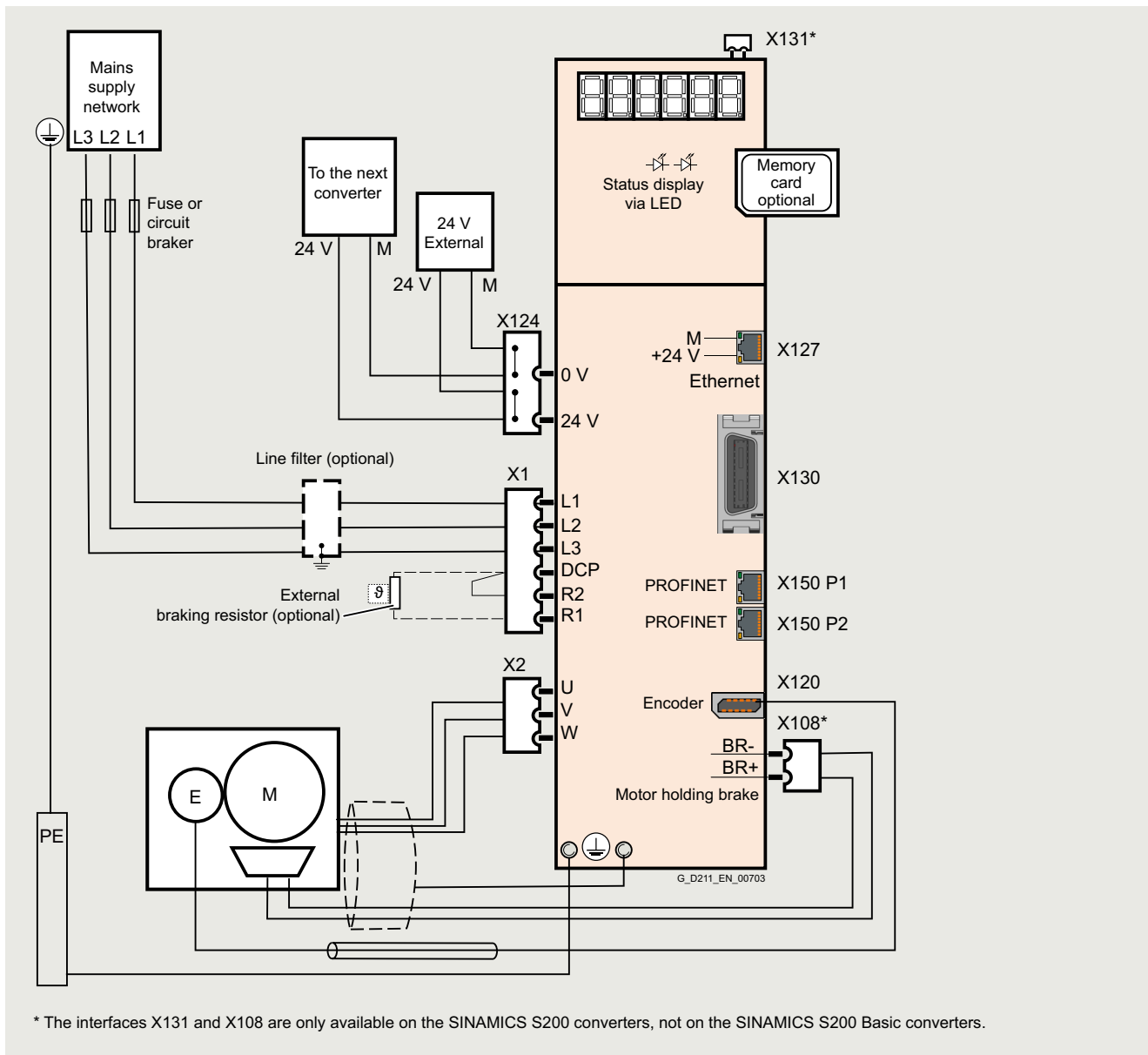



Connection example SINAMICS S200 Basic servo converters, PROFINET version, 3 AC

SINAMICS S200 servo converters

SINAMICS S200 Basic servo converters

Selection and ordering data

Description	Frame size	Article No.
200 ... 240 V 1 / 3 AC		
SINAMICS S200 Basic servo converters, PROFINET version with shield plate and push-in plugs, without memory card The shield clamp is included in the scope of delivery of the MOTION-CONNECT cable.		
	• 0.1 kW FSA	6SL5610-1BB10-1AF0
	• 0.2 kW FSA	6SL5610-1BB10-2AF0
	• 0.4 kW FSB	6SL5610-1BB10-4AF0
	• 0.75 kW FSC	6SL5610-1BB10-8AF0
	• 1 kW FSC	6SL5610-1BB11-0AF0

Recommended SIMATIC S7 controller

More information about SIMATIC S7-1500 and SIMATIC S7-1500 T-CPU controllers is available in Catalog ST 70 and on the internet at www.siemens.com/simatic-s7-1500

Accessories for SINAMICS S200 Basic servo converters, PROFINET version

Description	Article No.
SINAMICS SD card 8 GB Parameter assignments, firmware and licenses for a converter can be stored on the memory card.	
• Empty	6SL5970-0AA00-0AA0
• With firmware V6.2	6SL5570-0GC00-0AA0
Line filter Category C2 in IEC 61800-3 is attainable for motor cable lengths up to 30 m (98.5 ft) using a line filter.	
• ≤ 18 A for 200 ... 240 V 1 AC	6SL5550-0XB21-8CA0
• ≤ 5 A for 200 ... 240 V 3 AC	6SL3203-0BE15-0VA0
PROFINET I/O connector 20-pin	6SL3260-2MA00-0VA0
PROFINET I/O cable with 20-pin MDR connector, length: 1 m (3.28 ft)	6SL5562-1XX00-0AC0
PROFINET I/O adapter ¹⁾ for 20-pin MDR connector	6SL5562-1XX00-0AD0
Pre-assembled PROFINET cable with two RJ45 180° plugs, length: 1 m (3.28 ft)	6XV1871-5BH10
RJ45 data plug-in connector with 180° (straight) cable outlet	6GK1901-1BB10-2AA0
Standard PROFINET cable 4-core, sold by the meter, not assembled	6XV1840-2AH10
PROFINET patch cable For the networking of concatenated converters Industrial Ethernet TP cord, CAT 6 A, twisted pair line 4 × 2 cores, pre-assembled with two RJ45 connectors	
• 0.3 m (0.98 ft)	6XV1870-3QE30
• 0.5 m (1.64 ft)	6XV1870-3QE50

For further information about PROFINET cables refer on the internet at:

www.siemens.com/simatic-net

Spare parts for SINAMICS S200 Basic servo converters, PROFINET version

Description	Article No.
Shield connection kit including several shield plates and fixing screws	6SL5566-0AB00-0AA0
Terminal kit • for SINAMICS S200 Basic	6SL5668-0XX00-0AA0

¹⁾ Available soon.

Technical specifications

Unless explicitly specified otherwise, the following technical specifications are valid for all SINAMICS S200 Basic servo converters.

General technical specifications	
Mechanical specifications	
Vibratory load	
<ul style="list-style-type: none"> Storage ²⁾ acc. to IEC 60721-3-1: 1997 Transport ¹⁾ acc. to IEC 60721-3-2: 1997 Operation acc. to IEC 60721-3-3: 2002 - Test values acc. to IEC/EN 60068-2-6 	Class 1M2 Class 2M3 Class 3M1 Test Fc (sinusoidal) <ul style="list-style-type: none"> 10 ... 58 Hz: 0.075 mm amplitude of deflection 58 ... 200 Hz: 1 × g acceleration amplitude 10 frequency cycles per axis
Shock load	
<ul style="list-style-type: none"> Storage ²⁾ acc. to IEC 60721-3-1: 1997 Transport ¹⁾ acc. to IEC 60721-3-2: 1997 Operation acc. to IEC 60721-3-3: 2002 - Test values acc. to IEC/EN 60068-2-27 	Class 1M2 Class 2M3 Class 3M1 Test Ea (semi-sinusoidal) <ul style="list-style-type: none"> 5 × g peak acceleration 30 ms duration 3 shocks in all three axes in both directions
Environmental conditions	
Protection class According to IEC/EN 61800-5-1	Class I (with protective bonding circuit) and class III (SELV)
Degree of protection According to IEC/EN 60529	IP20 Mounting in control cabinet necessary
Permissible ambient temperature (air) in operation	0 ... 55 °C (32 ... 131 °F), >45 °C (113 °F) with power derating
Installation altitude	Up to max. 4000 m (13124 ft) (IEC/EN/UL), up to max. 2000 m (6562 ft) (CSA) <ul style="list-style-type: none"> Up to 2000 m (6562 ft) above sea level without power derating As from 2000 m (6562 ft) derating 10 % of current or 5 K per 1000 m (3281 ft) For more information on derating, see the operating instructions on the Internet at: www.siemens.com/sinamics-s200/documentation
Climatic conditions	
<ul style="list-style-type: none"> Storage ²⁾ acc. to IEC 60721-3-1: 1997 Transport ¹⁾ acc. to IEC 60721-3-2: 1997 Operation acc. to IEC 60721-3-3: 2002 	Class 2K4 -40 ... +70 °C (-40 ... +158 °F) Class 2K4 -40 ... +70 °C (-40 ... +158 °F) Max. relative air humidity: 95 % at 45 °C (113 °F) Better than class 3K3 0 ... 45 °C (32 ... 113 °F) without derating 45 ... 55 °C (113 ... 131 °F) with derating Max. relative air humidity: 95 % Ice formation, condensation, dripping water, spray water, splash water and jet water are not permitted (IEC/EN 60204, Teil 1)
Environmental class/harmful chemical substances	
<ul style="list-style-type: none"> Storage ²⁾ acc. to IEC 60721-3-1: 1997 Transport ¹⁾ acc. to IEC 60721-3-2: 1997 Operation acc. to IEC 60721-3-3: 2002 	Class 1C2 Class 2C2 Class 3C2
Organic/biological influences	
<ul style="list-style-type: none"> Storage ²⁾ acc. to IEC 60721-3-1: 1997 Transport ¹⁾ acc. to IEC 60721-3-2: 1997 Operation acc. to IEC 60721-3-3: 2002 	Class 1B1 Class 2B2 Class 3B1
Degree of pollution According to IEC/EN 61800-5-1	2
Standards	
Certificates of suitability	CE, UKCA, UL, RCM, EAC, KC, SEMI F47

¹⁾ In transport packaging.

²⁾ In product packaging.

SINAMICS S200 servo converters

SINAMICS S200 Basic servo converters

Technical specifications

Line voltage 200 ... 240 V 1 / 3 AC		SINAMICS S200 Basic servo converters, PROFINET version				
		6SL5610-1BB10-1AF0	6SL5610-1BB10-2AF0	6SL5610-1BB10-4AF0	6SL5610-1BB10-8AF0	6SL5610-1BB11-0AF0
Line supply connection						
• Supply voltage		200 ... 240 V -10 % ... +15 % 1 / 3 AC				
• Line frequency	Hz	50/60 ±10 %				
• Conductor cross-section, max.	mm ²	2.5				
• Line system configuration		Grounded TN/TT networks and ungrounded IT networks				
Depending on the motor-converter combination and the planned installation height, boundary conditions must be observed with regard to the line connection. For more information, see the operating instructions on the Internet at: www.siemens.com/sinamics-s200/documentation						
Rated current						
• 1 AC	A	1.2	2.0	3.0	8.0	8.0
• 3 AC	A	0.6	1.1	1.8	4.0	4.0
Inrush current	A	10.5	10.5	8.5	7.6	7.6
Power loss	W	12	15	24	45	46
Maximum permissible short-circuit current (SCCR)	kA	100				
Electronic power supply						
• Voltage		24 V -15 % ... +20 %				
• Power requirement, max.	A	1.2 without brake 2.2 with brake				
• Conductor cross-section, max.	mm ²	2.5				
Output						
• Rated power 230 V	kW	0.1	0.2	0.4	0.75	1.0
• Rated current	A	0.8	1.3	2.4	4.4	4.4
• Output current, max.	A	3.3	5.1	9.2	16.8	16.8
Overload capability		350 %				
Pulse frequency power unit	kHz	8				
Output frequency	Hz	0 ... 550				
Line filter		Category C2 (up to 30 m (98.5 ft) motor cable length), see accessories/line filter				
Braking resistor		Without			Integrated	
Digital inputs ¹⁾						
• Fast digital inputs		2				
-Low level		-30 V ... +5 V and ≤2 mA				
-High level		15 V ... 30 V				
-Current consumption, max.	mA	4				
-Delay time, typ., L → H	µs	5				
-Delay time, typ., H → L	µs	5				
-Galvanic isolation		No				
• General digital inputs		2				
-Low level		-30 V ... +5 V and ≤2 mA				
-High level		15 V ... 30 V				
-Current consumption, max.	mA	4				
-Delay time, typ., L → H	µs	10				
-Delay time, typ., H → L	µs	150				
-Galvanic isolation		Yes				
• Conductor cross-section, max.	mm ²	1.5				
Digital outputs ¹⁾						
• Load current per digital output, max.	mA	100				
• Delay time	ms	< 2				
• Conductor cross-section, max.	mm ²	1.5				
Frame Size		FSA	FSA	FSB	FSC	FSC
Cooling		Convection (without fan)				
Dimensions						
• Width	mm (in)	40 (1.57)	40 (1.57)	40 (1.57)	60 (2.36)	60 (2.36)
• Height	mm (in)	170 (6.69)	170 (6.69)	170 (6.69)	170 (6.69)	170 (6.69)
• Depth	mm (in)	135 (5.31)	135 (5.31)	170 (6.69)	195 (7.68)	195 (7.68)
Weight, approx.	kg (lb)	0.9 (1.98)	0.9 (1.98)	1.1 (2.43)	1.8 (3.97)	1.8 (3.97)

¹⁾ The specified delay times refer to the hardware. The actual reaction time depends on the time slot in which the digital input or digital output is processed.

Technical specifications

Technical specifications of the internal braking resistor

SINAMICS S200 Basic servo converters, PROFINET version			Internal braking resistor			
Type	Frame Size	Rated power kW	Resistance Ω	Max. continuous power W	Max. peak power W	Max. braking energy J
Line voltage 200 ... 240 V 1 / 3 AC						
6SL5610-1BB10-1AF0	FSA	0.1	Without			
6SL5610-1BB10-2AF0	FSA	0.2	Without			
6SL5610-1BB10-4AF0	FSB	0.4	Without			
6SL5610-1BB10-8AF0	FSC	0.75	50	30	1884	292
6SL5610-1BB11-0AF0	FSC	1.0	50	30	1884	292

For more information, see the operating instructions on the Internet at:
www.siemens.com/sinamics-s200/documentation

Dimensional drawings

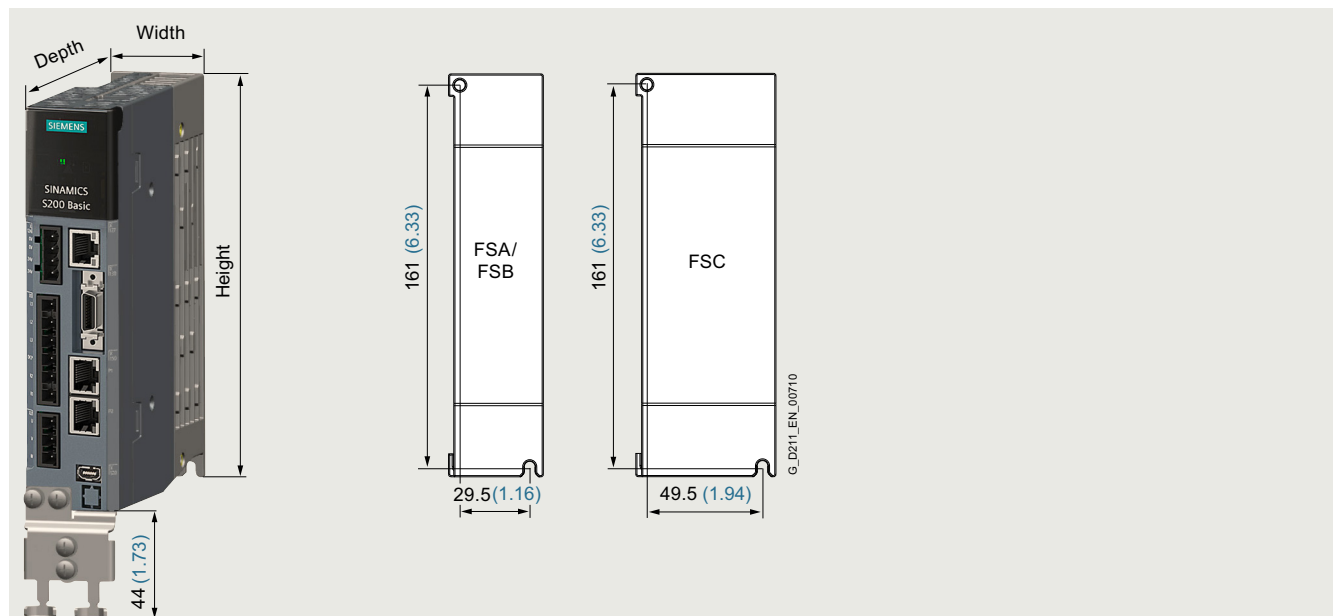

Frame size	a (Width)	b (Height)	c (Depth)	Fixing
FSA	40 (1.57)	170 (6.69)	135 (5.31)	2 x M4 / 2.5 Nm
FSB	40 (1.57)	170 (6.69)	170 (6.69)	
FSC	60 (2.36)	170 (6.69)	195 (7.68)	

Dimensions in mm (values in brackets are in inches)

SINAMICS S200 Basic servo converters, PROFINET version, FSA to FSC, 200 V 1 AC / 3 AC, IP20

SINAMICS S200 servo converters

SINAMICS S200 Basic servo converters

More information

Identification link according to IEC 61406 for SINAMICS S200

The ID link contains the article and serial number of the product. As a QR code, it replaces the previous data matrix code on the nameplate and takes you with the URL directly to a product information page on the internet with access to the technical documentation, data sheet, certificates, FAQs, product notifications, and catalogs. Paper package inserts become superfluous since the information is available electronically directly via the QR code, even years later. In this way, we are making a valuable contribution to the preservation of our environment. You don't need an additional app. Simply scan the QR code with your smartphone or tablet. According to IEC 61406, the QR code of an ID link is marked with a frame and a triangle at the bottom right.

With their globally unique identifiers, Siemens products are ready for Industry 4.0.

The ID serves as a connection to the administration shell with which modules of the digital twin can be provided.

Further documentation, such as the operating instructions, is available free on the internet at:

www.siemens.com/sinamics-s200/documentation

Detailed information on the SINAMICS S200 drive system, including the latest technical documentation (brochures, tutorials, dimensional drawings, certificates, manuals and operating instructions), is available on the internet at:

www.siemens.com/sinamics-s200

and is also available via the Siemens Product Configurator on the internet.

The Siemens Product Configurator can be found in SiePortal at the following address:

www.siemens.com/sinamics-s200/configuration

Overview

SINAMICS S200 servo converters



SINAMICS S200 servo converters, 200 ... 240 V 1 AC / 3 AC, PROFINET, frame sizes FSA, FSB and FSC



SINAMICS S200 servo converters, 380 ... 480 V 3 AC, PROFINET, frame sizes FSA, FSB, FSC and FSD

The SINAMICS S200 servo converters consist of a basic version and a standard version with pulse train input position control (PTI)¹⁾ or PROFINET RT/IRT (PN) to meet various needs of applications and works perfectly together with SIMATIC controllers.

- SINAMICS S200 Basic servo converters, power range 0.1 to 1 kW at 200 ... 240 V 1 AC / 3 AC
- SINAMICS S200 servo converters, power range 0.1 to 1 kW at 200 ... 240 V 1 AC / 3 AC and 0.2 to 7 kW at 380 ... 480 V 3 AC

¹⁾ Available soon.

SINAMICS S200 servo converters

SINAMICS S200 servo converters

Design

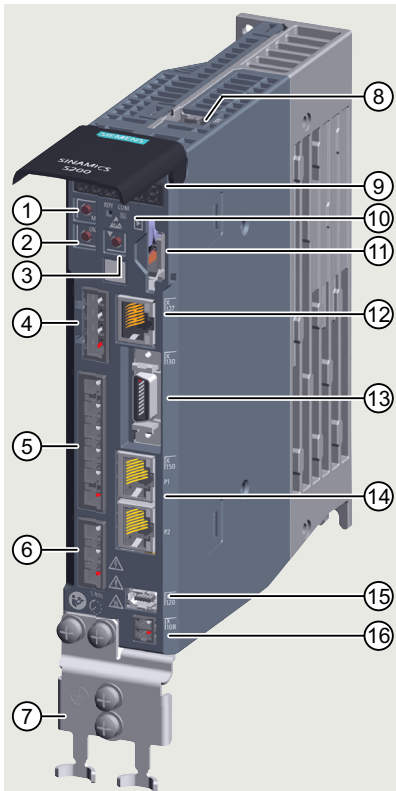

- | | |
|---|--|
| ① M button | ⑨ 6-digit display |
| ② OK button | ⑩ LED status indicators |
| ③ DOWN button | ⑪ Memory card slot |
| ④ 24 V DC power supply - X124 | ⑫ Service interface (Ethernet) - X127 |
| ⑤ Mains and braking resistor interface - X1 | ⑬ Control/status inputs and outputs - X130 |
| ⑥ Motor power interface - X2 | ⑭ PROFINET interface - X150 |
| ⑦ Shield plate | ⑮ Encoder interface - X120 |
| ⑧ STO interface - X131 ¹⁾ | ⑯ Motor holding brake interface - X108 ¹⁾ |

¹⁾ The interfaces X131 and X108 are only available on the SINAMICS S200 converters, not on the SINAMICS S200 Basic converters.

Interface overview SINAMICS S200 servo converters, PROFINET version

G_ID211_EN_00704

Function

Closed-loop control	Servo control with DSC
Control functions	<ul style="list-style-type: none"> Speed control with encoder Dynamic Servo Control (DSC) Basic positioner (EPoS) Ramp-function generator Torque setpoint limitation Current controller and current controller adaptation suitably adjusted for SIMOTICS S-1FL2 servomotors One Button Tuning with moment of inertia estimator and reference model Local measuring probe Simple brake control Direction reversal without changing the setpoint channel Travel to fixed stop Vertical axis Speed controller adaptation Thermal monitoring for power unit and servomotor Pulse train encoder output (PTO)
Protection functions	<ul style="list-style-type: none"> Undervoltage DC link voltage Overvoltage DC link voltage Overcurrent power unit Overcurrent motor Overload power unit (I^2t) Short-circuit Ground fault Temperature rise servomotor Temperature rise power unit
Safety Integrated	Safe Torque Off (STO)
Commissioning	<ul style="list-style-type: none"> Identification of the SIMOTICS S-1FL2 servomotors via the electronic type plate Automatic controller optimization

SINAMICS S200 servo converters

SINAMICS S200 servo converters

Integration

2

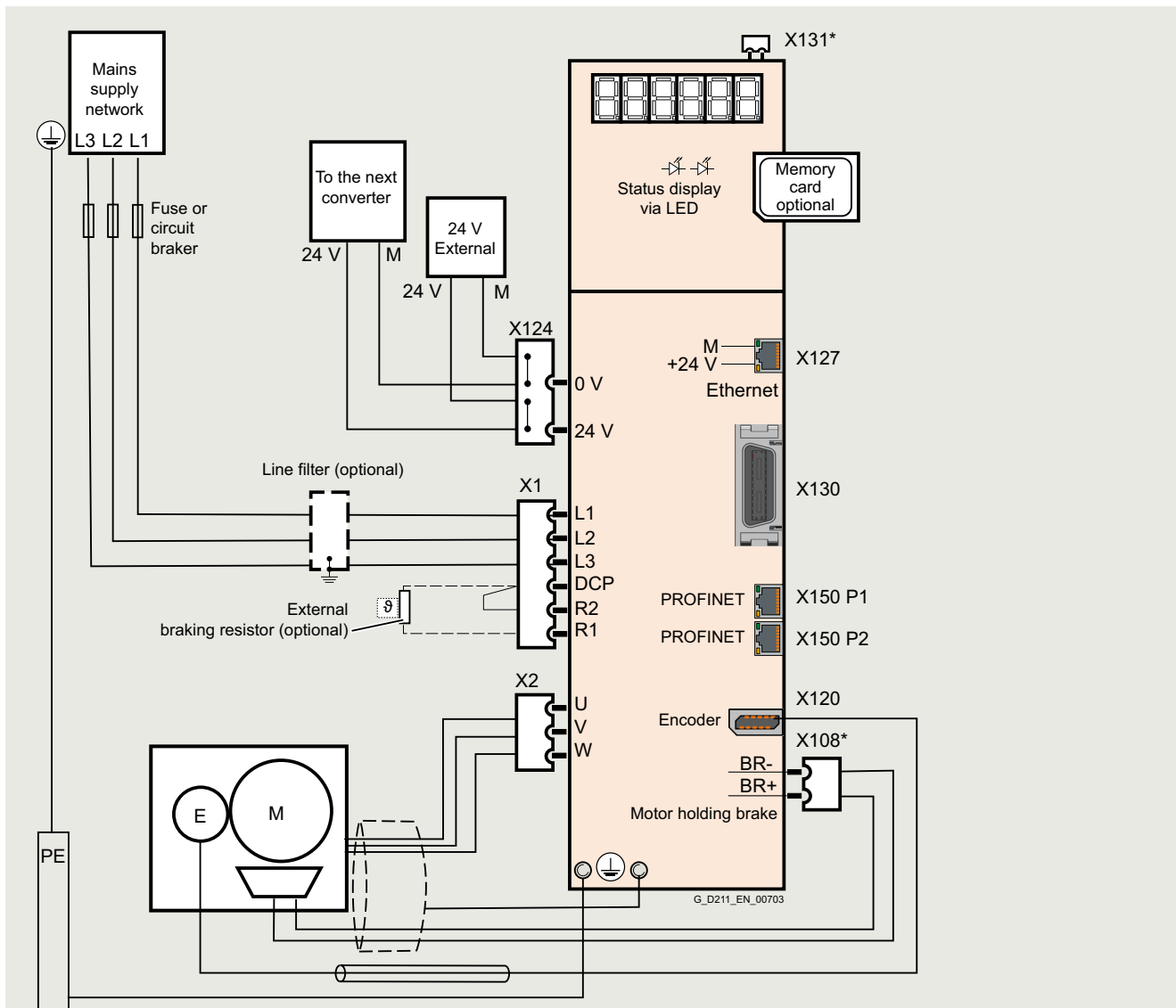



* The interfaces X131 and X108 are only available on the SINAMICS S200 converters, not on the SINAMICS S200 Basic converters.





Connection example SINAMICS S200 servo converters, PROFINET version, 3 AC

SINAMICS S200 servo converters

SINAMICS S200 servo converters

Selection and ordering data

Description	Frame size	Article No.
200 ... 240 V 1 / 3 AC		
SINAMICS S200 servo converters, PROFINET version with shield plate and push-in plugs, without memory card The shield clamp is included in the scope of delivery of the MOTION-CONNECT cable.		
	• 0.1 kW FSA	6SL5510-1BB10-1AF0
	• 0.2 kW FSA	6SL5510-1BB10-2AF0
	• 0.4 kW FSB	6SL5510-1BB10-4AF0
	• 0.75 kW FSC	6SL5510-1BB10-8AF0
	• 1 kW FSC	6SL5510-1BB11-0AF0

Description	Frame size	Article No.
380 ... 480 V 3 AC		
SINAMICS S200 servo converters, PROFINET version with shield plate and push-in plugs, without memory card The shield clamp is included in the scope of delivery of the MOTION-CONNECT cable.		
	• 0.2 kW FSA	6SL5510-1BE10-2AF0
	• 0.4 kW FSA	6SL5510-1BE10-4AF0
	• 0.75 kW FSB	6SL5510-1BE10-8AF0
	• 1 kW FSB	6SL5510-1BE11-0AF0
	• 1.75 kW FSC	6SL5510-1BE11-5AF0
	• 2.5 kW FSC	6SL5510-1BE12-5AF0
	• 3.5 kW FSD	6SL5510-1BE13-5AF0
	• 5 kW FSD	6SL5510-1BE15-0AF0
	• 7 kW FSD	6SL5510-1BE17-0AF0

SINAMICS S200 servo converters

SINAMICS S200 servo converters

Selection and ordering data

Accessories for SINAMICS S200 servo converters, PROFINET version

Description	Article No.
SINAMICS SD card 8 GB Parameter assignments, firmware and licenses for a converter can be stored on the memory card.	
<ul style="list-style-type: none"> • Empty 	6SL5970-0AA00-0AA0
<ul style="list-style-type: none"> • With firmware V6.2 	6SL5570-0GC00-0AA0
Line filter Category C2 in IEC 61800-3 is attainable for motor cable lengths up to 30 m (98.5 ft) using a line filter.	
<ul style="list-style-type: none"> • ≤ 18 A for 200 ... 240 V 1 AC, frame sizes FSA, FSB, FSC 	6SL5550-0XB21-8CA0
<ul style="list-style-type: none"> • ≤ 5 A for 200 ... 240 V 3 AC, frame sizes FSA, FSB, FSC 	6SL3203-0BE15-0VA0
<ul style="list-style-type: none"> • ≤ 5 A for 380 ... 480 V 3 AC, frame sizes FSA and FSB 	6SL5550-0XE20-5CA0
<ul style="list-style-type: none"> • ≤ 12 A for 380 ... 480 V 3 AC, frame size FSC 	6SL5550-0XE21-2CA0
<ul style="list-style-type: none"> • ≤ 20 A for 380 ... 480 V 3 AC, frame size FSD 	6SL5550-0XE22-0CA0
PROFINET I/O connector 20-pin	6SL3260-2MA00-0VA0
PROFINET I/O cable with 20-pin MDR connector, length: 1 m (3.28 ft)	6SL5562-1XX00-0AC0
PROFINET I/O adapter ¹⁾ for 20-pin MDR connector	6SL5562-1XX00-0AD0
Pre-assembled PROFINET cable with two RJ45 180° plugs, length: 1 m (3.28 ft)	6XV1871-5BH10
RJ45 data plug-in connector with 180° (straight) cable outlet	6GK1901-1BB10-2AA0
Standard PROFINET cable 4-core, sold by the meter, not assembled	6XV1840-2AH10
PROFINET patch cable For the networking of concatenated converters Industrial Ethernet TP cord, CAT 6 A, twisted pair line 4 × 2 cores, pre-assembled with two RJ45 connectors	
<ul style="list-style-type: none"> • 0.3 m (0.98 ft) 	6XV1870-3QE30
<ul style="list-style-type: none"> • 0.5 m (1.64 ft) 	6XV1870-3QE50

For further information about PROFINET cables refer on the internet at:
www.siemens.com/simatic-net

Recommended SIMATIC S7 controller

More information about SIMATIC S7-1500 and SIMATIC S7-1500 T-CPU controllers is available in Catalog ST 70 and on the internet at
www.siemens.com/simatic-s7-1500

Spare parts for SINAMICS S200 servo converters, PROFINET version

Description	Article No.
Shield connection kit including several shield plates and fixing screws	6SL5566-0AB00-0AA0
Terminal kit <ul style="list-style-type: none"> • for SINAMICS S200 	6SL5568-0XX00-0AA0
Ersatzlüfter <ul style="list-style-type: none"> • for SINAMICS S200, 400 V Version, FSC • for SINAMICS S200, 400 V Version, FSD 	6SL5566-0CE00-0AA0 6SL5566-0DE00-0AA0

¹⁾ Available soon.

Technical specifications

Unless explicitly specified otherwise, the following technical specifications are valid for all SINAMICS S200 servo converters.

General technical specifications	
Mechanical specifications	
Vibratory load	
<ul style="list-style-type: none"> Storage ²⁾ acc. to IEC 60721-3-1: 1997 Transport ¹⁾ acc. to IEC 60721-3-2: 1997 Operation acc. to IEC 60721-3-3: 2002 -Test values acc. to IEC/EN 60068-2-6 	Class 1M2 Class 2M3 Class 3M1 Test Fc (sinusoidal) <ul style="list-style-type: none"> 10 ... 58 Hz: 0.075 mm amplitude of deflection 58 ... 200 Hz: 1 × g acceleration amplitude 10 frequency cycles per axis
Shock load	
<ul style="list-style-type: none"> Storage ²⁾ acc. to IEC 60721-3-1: 1997 Transport ¹⁾ acc. to IEC 60721-3-2: 1997 Operation acc. to IEC 60721-3-3: 2002 -Test values acc. to IEC/EN 60068-2-27 	Class 1M2 Class 2M3 Class 3M1 Test Ea (semi-sinusoidal) <ul style="list-style-type: none"> 5 × g peak acceleration 30 ms duration 3 shocks in all three axes in both directions
Environmental conditions	
Protection class According to IEC/EN 61800-5-1	Class I (with protective bonding circuit) and class III (SELV)
Degree of protection According to IEC/EN 60529	IP20 Mounting in control cabinet necessary
Permissible ambient temperature (air) in operation	0 ... 55 °C (32 ... 131 °F), >45 °C (113 °F) with power derating
Installation altitude	Up to max. 4000 m (13124 ft) (IEC/EN/UL), up to max. 2000 m (6562 ft) (CSA) <ul style="list-style-type: none"> Up to 2000 m (6562 ft) above sea level without power derating As from 2000 m (6562 ft) derating 10 % of current or 5 K per 1000 m (3281 ft) For more information on derating, see the operating instructions on the Internet at: www.siemens.com/sinamics-s200/documentation
Climatic conditions	
<ul style="list-style-type: none"> Storage ²⁾ acc. to IEC 60721-3-1: 1997 Transport ¹⁾ acc. to IEC 60721-3-2: 1997 Operation acc. to IEC 60721-3-3: 2002 	Class 2K4 -40 ... +70 °C (-40 ... +158 °F) Class 2K4 -40 ... +70 °C (-40 ... +158 °F) Max. relative air humidity: 95 % at 45 °C (113 °F) Better than class 3K3 0 ... 45 °C (32 ... 113 °F) without derating 45 ... 55 °C (113 ... 131 °F) with derating Max. relative air humidity: 95 % Ice formation, condensation, dripping water, spray water, splash water and jet water are not permitted (IEC/EN 60204, Teil 1)
Environmental class/harmful chemical substances	
<ul style="list-style-type: none"> Storage ²⁾ acc. to IEC 60721-3-1: 1997 Transport ¹⁾ acc. to IEC 60721-3-2: 1997 Operation acc. to IEC 60721-3-3: 2002 	Class 1C2 Class 2C2 Class 3C2
Organic/biological influences	
<ul style="list-style-type: none"> Storage ²⁾ acc. to IEC 60721-3-1: 1997 Transport ¹⁾ acc. to IEC 60721-3-2: 1997 Operation acc. to IEC 60721-3-3: 2002 	Class 1B1 Class 2B2 Class 3B1
Degree of pollution According to IEC/EN 61800-5-1	2
Standards	
Certificates of suitability	CE, UKCA, UL, RCM, EAC, KC, SEMI F47
Integrated safety functions and functional safety	Safe Torque Off (STO) acc. to <ul style="list-style-type: none"> SIL 3 per IEC 61508 part 1 to 3 (2010) and IEC 61800-5-2 (2016) PL e per ISO 13849 part 1 (2015) Category 3 per ISO 13849 part 1 (2015)

¹⁾ In transport packaging.

²⁾ In product packaging.

SINAMICS S200 servo converters

SINAMICS S200 servo converters

Technical specifications

Line voltage 200 ... 240 V 1 / 3 AC		SINAMICS S200 servo converters, PROFINET version					
		6SL5510-1BB10-1AF0	6SL5510-1BB10-2AF0	6SL5510-1BB10-4AF0	6SL5510-1BB10-8AF0	6SL5510-1BB11-0AF0	
Line supply connection							
• Supply voltage		200 ... 240 V -10 % ... +15 % 1 / 3 AC					
• Line frequency	Hz	50/60 ±10 %					
• Conductor cross-section, max.	mm ²	2.5					
• Line system configuration		Grounded TN/TT networks and ungrounded IT networks					
Depending on the motor-converter combination and the planned installation height, boundary conditions must be observed with regard to the line connection. For more information, see the operating instructions on the Internet at: www.siemens.com/sinamics-s200/documentation							
Rated current							
• 1 AC	A	1.2	2.0	3.0	8.0	8.0	
• 3 AC	A	0.6	1.1	1.8	4.0	4.0	
Inrush current		A	10.5	10.5	8.5	7.6	7.6
Power loss		W	12	15	24	45	46
Maximum permissible short-circuit current (SCCR)		kA	100				
Electronic power supply							
• Voltage		24 V -15 % ... +20 %					
• Power requirement, max.	A	1.2 without brake 2.2 with brake					
• Conductor cross-section, max.	mm ²	2.5					
Output							
• Rated power 230 V	kW	0.1	0.2	0.4	0.75	1.0	
• Rated current	A	0.8	1.3	2.4	4.4	4.4	
• Output current, max.	A	3.3	5.1	9.2	16.8	16.8	
Overload capability		350 %					
Pulse frequency power unit		kHz	8				
Output frequency		Hz	0 ... 550				
Line filter		Category C2 (up to 30 m (98.5 ft) motor cable length), see accessories/line filter					
Braking resistor		Without		Integrated			
Digital inputs ¹⁾							
• Fast digital inputs		2					
-Low level		-30 V ... +5 V and ≤2 mA					
-High level		15 V ... 30 V					
-Current consumption, max.	mA	4					
-Delay time, typ., L → H	µs	5					
-Delay time, typ., H → L	µs	5					
-Galvanic isolation		No					
• General digital inputs		2					
-Low level		-30 V ... +5 V and ≤2 mA					
-High level		15 V ... 30 V					
-Current consumption, max.	mA	4					
-Delay time, typ., L → H	µs	10					
-Delay time, typ., H → L	µs	150					
-Galvanic isolation		Yes					
• Conductor cross-section, max.	mm ²	1.5					
Digital outputs ¹⁾							
• Load current per digital output, max.	mA	100					
• Delay time	ms	< 2					
• Conductor cross-section, max.	mm ²	1.5					
Frame Size		FSA	FSA	FSB	FSC	FSC	
Cooling		Convection (without fan)					
Dimensions							
• Width	mm (in)	40 (1.57)	40 (1.57)	40 (1.57)	60 (2.36)	60 (2.36)	
• Height	mm (in)	170 (6.69)	170 (6.69)	170 (6.69)	170 (6.69)	170 (6.69)	
• Depth	mm (in)	135 (5.31)	135 (5.31)	170 (6.69)	195 (7.68)	195 (7.68)	
Weight, approx.		kg (lb)	0.9 (1.98)	0.9 (1.98)	1.1 (2.43)	1.8 (3.97)	1.8 (3.97)

¹⁾ The specified delay times refer to the hardware. The actual reaction time depends on the time slot in which the digital input or digital output is processed.

Technical specifications

Line voltage 380 ... 480 V 3 AC		SINAMICS S200 servo converters, PROFINET version								
		6SL5510-1BE10-2AFO	6SL5510-1BE10-4AFO	6SL5510-1BE10-8AFO	6SL5510-1BE11-0AFO	6SL5510-1BE11-5AFO	6SL5510-1BE12-0AFO	6SL5510-1BE13-5AFO	6SL5510-1BE15-0AFO	6SL5510-1BE17-0AFO
Line supply connection		380 ... 480 V -10 % ... +15 % 3 AC								
• Supply voltage		50/60 ±10 %								
• Line frequency	Hz	2.5								
• Conductor cross-section, max.	mm ²	Grounded TN/TT networks and ungrounded IT networks								
• Line system configuration		Depending on the motor-converter combination and the planned installation height, boundary conditions must be observed with regard to the line connection. For more information, see the operating instructions on the Internet at: www.siemens.com/sinamics-s200/documentation								
Rated current	A	1.3	1.3	2.5	3.0	5.5	8.0	11.0	13.0	14.2
Inrush current	A	7.5	7.5	7.5	7.5	15.0	15.0	3.0	3.0	3.0
Power loss	W	31	32	46	54	84	123	171	194	205
Maximum permissible short-circuit current (SCCR)	kA	65								
Electronic power supply		24 V -15 % ... +20 %								
• Voltage		1.2 without brake								
• Power requirement, max.	A	3.2 with brake								
• Conductor cross-section, max.	mm ²	2.5								
Output										
• Rated power 400 V	kW	0.2	0.4	0.75	1.0	1.75	2.5	3.5	5.0	7.0
• Rated current	A	1.3	1.3	2.5	3.0	5.3	7.8	11.0	12.6	13.2
• Output current, max.	A	5.1	6.0	9.3	11.5	20.0	26.5	38.1	38.8	37.4
Overload capability		350 %				300 %				
Pulse frequency power unit	kHz	8								
Output frequency	Hz	0 ... 550								
Line filter		Category C2 (up to 30 m (98.5 ft) motor cable length), see accessories/line filter								
Braking resistor		Integrated								
Digital inputs ¹⁾										
• Fast digital inputs		2								
-Low level		-30 V ... +5 V and ≤2 mA								
-High level		15 V ... 30 V								
-Current consumption, max.	mA	4								
-Delay time, typ., L → H	µs	5								
-Delay time, typ., H → L	µs	5								
-Galvanic isolation		No								
• General digital inputs		2								
-Low level		-30 V ... +5 V and ≤2 mA								
-High level		15 V ... 30 V								
-Current consumption, max.	mA	4								
-Delay time, typ., L → H	µs	10								
-Delay time, typ., H → L	µs	150								
-Galvanic isolation		Yes								
• Conductor cross-section, max.	mm ²	1.5								
Digital outputs ¹⁾		2								
• Load current per digital output, max.	mA	100								
• Delay time	ms	< 2								
• Conductor cross-section, max.	mm ²	1.5								
Frame Size		FSA	FSA	FSB	FSB	FSC	FSC	FSD	FSD	FSD
Cooling		Convection (without fan)				Air cooling with integrated fan				
Dimensions										
• Width	mm (in)	50 (1.97)	50 (1.97)	60 (2.36)	60 (2.36)	70 (2.76)	70 (2.76)	95 (3.74)	95 (3.74)	95 (3.74)
• Height	mm (in)	180 (7.09)	180 (7.09)	180 (7.09)	180 (7.09)	180 (7.09)	180 (7.09)	260 (10.24)	260 (10.24)	260 (10.24)
• Depth	mm (in)	200 (7.87)	200 (7.87)	200 (7.87)	200 (7.87)	200 (7.87)	200 (7.87)	230 (9.06)	230 (9.06)	230 (9.06)
Weight, approx.	kg (lb)	1.5 (3.31)	1.5 (3.31)	1.9 (4.19)	1.9 (4.19)	2.0 (4.41)	2.0 (4.41)	4.5 (9.92)	4.5 (9.92)	4.5 (9.92)

¹⁾ The specified delay times refer to the hardware. The actual reaction time depends on the time slot in which the digital input or digital output is processed.

SINAMICS S200 servo converters

SINAMICS S200 servo converters

Technical specifications

Technical specifications of the internal braking resistor

SINAMICS S200 servo converters, PROFINET version			Internal braking resistor			
Type	Frame Size	Rated power kW	Resistance Ω	Max. continuous power W	Max. peak power W	Max. braking energy J
Line voltage 200 ... 240 V 1 / 3 AC						
6SL5510-1BB10-1AF0	FSA	0.1	Without			
6SL5510-1BB10-2AF0	FSA	0.2	200	8	373	63
6SL5510-1BB10-4AF0	FSB	0.4	100	16	742	123
6SL5510-1BB10-8AF0	FSC	0.75	50	30	1884	292
6SL5510-1BB11-0AF0	FSC	1.0	50	30	1884	292
Line voltage 380 ... 480 V 3 AC						
6SL5510-1BE10-2AF0	FSA	0.2	500	14	754	210
6SL5510-1BE10-4AF0	FSA	0.4	500	14	754	210
6SL5510-1BE10-8AF0	FSB	0.75	160	15	2312	637
6SL5510-1BE11-0AF0	FSB	1.0	160	15	2312	637
6SL5510-1BE11-5AF0	FSC	1.75	70	30	5086	1137
6SL5510-1BE12-5AF0	FSC	2.5	70	30	5086	1137
6SL5510-1BE13-5AF0	FSD	3.5	27	65	9896	1948
6SL5510-1BE15-0AF0	FSD	5.0	27	65	9896	1948
6SL5510-1BE17-0AF0	FSD	7.0	27	65	9896	1948

For more information, see the operating instructions on the Internet at:
www.siemens.com/sinamics-s200/documentation

Dimensional drawings

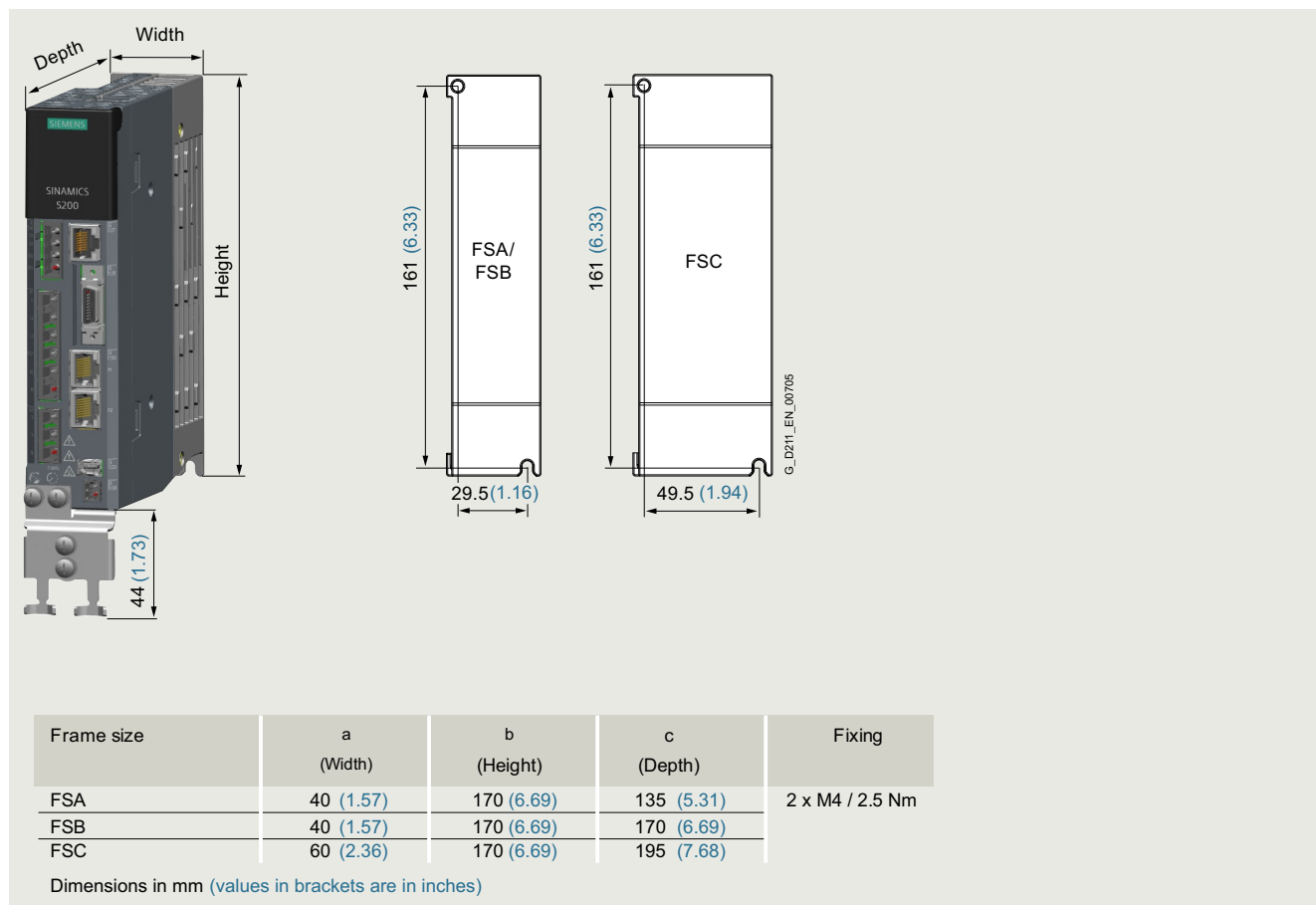

SINAMICS S200 servo converters, PROFINET version, FSA to FSC, 200 V 1 AC / 3 AC, IP20

Dimensional drawings

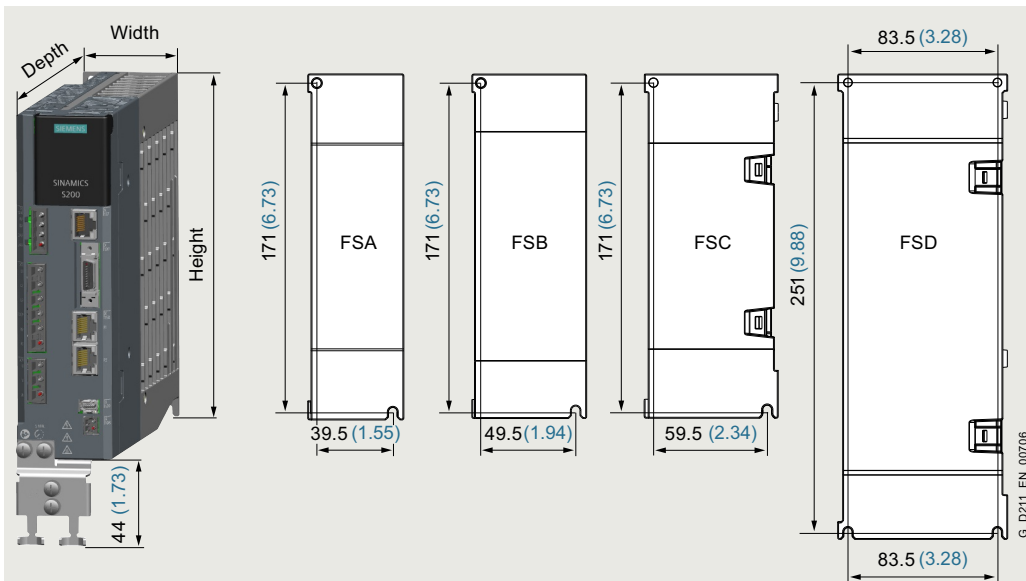

Frame size	a (Width)	b (Height)	c (Depth)	Fixing
FSA	50 (1.97)	180 (7.09)	200 (7.87)	2 x M4 / 2.5 Nm
FSB	60 (2.36)	180 (7.09)	200 (7.87)	
FSC	70 (2.75)	180 (7.09)	200 (7.87)	
FSD	95 (3.74)	260 (10.24)	230 (9.05)	4 x M4 / 2.5 Nm

Dimensions in mm (values in brackets are in inches)

SINAMICS S200 servo converters, PROFINET version, FSA to FSD, 400 V 3 AC, IP20

More information

Identification link according to IEC 61406 for SINAMICS S200

The ID link contains the article and serial number of the product. As a QR code, it replaces the previous data matrix code on the nameplate and takes you with the URL directly to a product information page on the internet with access to the technical documentation, data sheet, certificates, FAQs, product notifications, and catalogs. Paper package inserts become superfluous since the information is available electronically directly via the QR code, even years later. In this way, we are making a valuable contribution to the preservation of our environment. You don't need an additional app. Simply scan the QR code with your smartphone or tablet. According to IEC 61406, the QR code of an ID link is marked with a frame and a triangle at the bottom right.

With their globally unique identifiers, Siemens products are ready for Industry 4.0.

The ID serves as a connection to the administration shell with which modules of the digital twin can be provided.

Further documentation, such as the operating instructions, is available free on the internet at:
www.siemens.com/sinamics-s200/documentation

Detailed information on the SINAMICS S200 drive system, including the latest technical documentation (brochures, tutorials, dimensional drawings, certificates, manuals and operating instructions), is available on the internet at:
www.siemens.com/sinamics-s200

and is also available via the Siemens Product Configurator on the internet.

The Siemens Product Configurator can be found in SiePortal at the following address:

www.siemens.com/sinamics-s200/configuration

SINAMICS S200 servo converters

Line-side components

Line filters

Overview



Example: Line filter for SINAMICS S200

It is recommended to use a line filter to protect the system from high frequency noise.

With one of the recommended line filters, IEC 61800-3 category C2 can be reached in combination with SINAMICS S200 for motor cable lengths up to 30 m (98.5 ft).

Selection and ordering data

SINAMICS S200 Basic servo converters	Rated current	Recommended line filter
Frame size	A	Category C2 in EN 61800-3 is attainable for motor cable lengths up to 30 m (98.5 ft). Article No.
Line voltage 200 ... 240 V 1 AC		
FSA	18	6SL5550-0XB21-8CA0
FSB		
FSC		
Line voltage 200 ... 240 V 3 AC		
FSA	5	6SL3203-0BE15-0VA0
FSB		
FSC		
SINAMICS S200 servo converters	Rated current	Recommended line filter
Frame size	A	Category C2 in EN 61800-3 is attainable for motor cable lengths up to 30 m (98.5 ft). Article No.
Line voltage 200 ... 240 V 1 AC		
FSA	18	6SL5550-0XB21-8CA0
FSB		
FSC		
Line voltage 200 ... 240 V 3 AC		
FSA	5	6SL3203-0BE15-0VA0
FSB		
FSC		
Line voltage 380 ... 480 V 3 AC		
FSA	5	6SL5550-0XE20-5CA0
FSB		
FSC	12	
FSD	20	6SL5550-0XE21-2CA0
		6SL5550-0XE22-0CA0

Technical specifications

Line voltage 200 ... 240 V 1 AC	Line filter	
	6SL5550-0XB21-8CA0	
Rated current	A	18
Power loss	W	4.7
Line/load connection	Screw terminals	
• Conductor cross-section -For single-conductor connection	mm ²	0.25 ... 6 AWG 24 ... 10
-For flexible cables	mm ²	0.25 ... 4 AWG 24 ... 12
PE connection	M5 screw stud	
Degree of protection	IP20	
Dimensions		
• Width	mm (in)	58 (2.28)
• Height	mm (in)	155 (6.10)
• Depth	mm (in)	53 (2.09)
Weight, approx.	kg (lb)	0.75 (1.65)
Leakage current	mA	11.84
Suitable for SINAMICS S200 Basic servo converters	Type	200 ... 240 V 1 AC 6SL5610-1BB10-1AF0 (1.2 A) 6SL5610-1BB10-2AF0 (2.0 A) 6SL5610-1BB10-4AF0 (3.0 A) 6SL5610-1BB10-8AF0 (8.0 A) 6SL5610-1BB11-0AF0 (8.0 A)
Suitable for SINAMICS S200 servo converters	Type	200 ... 240 V 1 AC 6SL5510-1BB10-1AF0 (1.2 A) 6SL5510-1BB10-2AF0 (2.0 A) 6SL5510-1BB10-4AF0 (3.0 A) 6SL5510-1BB10-8AF0 (8.0 A) 6SL5510-1BB11-0AF0 (8.0 A)

Technical specifications

Line voltage 275 ... 480 V 3 AC		Line filter			
		6SL3203-0BE15-0VA0	6SL5550-0XE20-5CA0	6SL5550-0XE21-2CA0	6SL5550-0XE22-0CA0
Rated current	A	5	5	12	20
Power loss	W	2	2.7	3.9	10.1
Line/load connection		Screw terminals	Screw terminals	Screw terminals	Screw terminals
• Conductor cross-section -For single-conductor connection	mm ²	0.25 ... 6 AWG 24 ... 10	0.25 ... 6 AWG 24 ... 10	0.25 ... 6 AWG 24 ... 10	0.25 ... 6 AWG 24 ... 10
-For flexible cables	mm ²	0.25 ... 4 AWG 24 ... 12	0.25 ... 4 AWG 24 ... 12	0.25 ... 4 AWG 24 ... 12	0.25 ... 4 AWG 24 ... 12
PE connection		M6 screw stud	M6 screw stud	M6 screw stud	M6 screw stud
Degree of protection		IP20	IP20	IP20	IP20
Dimensions					
• Width	mm (in)	55 (2.17)	55 (2.17)	75 (2.95)	60 (2.36)
• Height	mm (in)	170 (6.69)	170 (6.69)	195 (7.68)	250 (9.84)
• Depth	mm (in)	130 (5.12)	130 (5.12)	140 (5.51)	130 (5.12)
Weight, approx.	kg (lb)	0.67 (1.48)	0.72 (1.59)	1.34 (2.95)	1.5 (3.31)
Leakage current	mA	4.31	4.37	7.05	8.88
Suitable for SINAMICS S200 Basic servo converters	Type	200 ... 240 V 3 AC 6SL5610-1BB10-1AF0 (0.6 A) 6SL5610-1BB10-2AF0 (1.1 A) 6SL5610-1BB10-4AF0 (1.8 A) 6SL5510-1BB10-8AF0 (4.0 A) 6SL5510-1BB11-0AF0 (4.0 A)	–	–	–
Suitable for SINAMICS S200 servo converters	Type	200 ... 240 V 3 AC 6SL5510-1BB10-1AF0 (0.6 A) 6SL5510-1BB10-2AF0 (1.1 A) 6SL5510-1BB10-4AF0 (1.8 A) 6SL5510-1BB10-8AF0 (4.0 A) 6SL5510-1BB11-0AF0 (4.0 A)	380 ... 480 V 3 AC 6SL5510-1BE10-2AF0 (1.3 A) 6SL5510-1BE10-4AF0 (1.3 A) 6SL5510-1BE10-8AF0 (2.5 A) 6SL5510-1BE11-0AF0 (3.0 A)	380 ... 480 V 3 AC 6SL5510-1BE11-5AF0 (5.5 A) 6SL5510-1BE12-5AF0 (8.0 A)	380 ... 480 V 3 AC 6SL5510-1BE13-5AF0 (11.0 A) 6SL5510-1BE15-0AF0 (13.0 A) 6SL5510-1BE17-0AF0 (14.2 A)

More information

Detailed information on the SINAMICS S200 drive system, including the latest technical documentation (brochures, tutorials, dimensional drawings, certificates, manuals and operating instructions), is available on the internet at:
www.siemens.com/sinamics-s200

and is also available via the Siemens Product Configurator on the internet.

The Siemens Product Configurator can be found in SiePortal at the following address:
www.siemens.com/sinamics-s200/configuration

SINAMICS S200 servo converters

Line-side components

Recommended line-side overcurrent protection devices

Overview

Overcurrent protection devices are necessary for the operation of the converters. The following table lists recommendations for fuses.

- Siemens fuses of type 3NA3 and 3NW6 for use in the area of validity of IEC
- UL-listed fuses Class J for use in USA and Canada

Recommendations on further overcurrent protection devices are available at:

- For SINAMICS S200
www.siemens.com/sinamics-s200/ocpd

The Short Circuit Current Rating (SCCR) according to UL for industrial control cabinet installations to NEC Article 409 or UL 508A/508C or UL 61800-5-1 is as follows for Class J fuses for

- SINAMICS S200 at 240 V 1 AC / 3 AC: 100 kA
- SINAMICS S200 at 480 V 3 AC: 65 kA

SCCR and ICC values for combination with further overcurrent protection devices are available at:

- For SINAMICS S200
www.siemens.com/sinamics-s200/ocpd

Notes for installations in Canada:

The converters are intended for line supply systems with overvoltage category III.

More information is available in the technical documentation on the internet at:

www.siemens.com/sinamics-s200/documentation

Additional information about the listed Siemens fuses is available in Catalog LV 10 as well as in SiePortal.

Selection and ordering data

Rated power kW	SINAMICS S200 Basic Type 6SL5610-...	SINAMICS S200 Type 6SL5510-...	IEC-compliant Fuse		UL/cUL-compliant Fuse type Rated voltage 600 V AC	
			Current A	3NA3 3NW6 Article No.	Class	Current A
Line voltage 200 ... 240 V 1 AC / 3 AC						
0.1	6SL5610-1BB10-1AF0	6SL5510-1BB10-1AF0	4	3NA3804 3NW6304-1	J J	3 3
0.2	6SL5610-1BB10-2AF0	6SL5510-1BB10-2AF0	4	3NA3804 3NW6304-1	J J	3 3
0.4	6SL5610-1BB10-4AF0	6SL5510-1BB10-4AF0	6	3NA3801 3NW6301-1	J J	6 6
0.75	6SL5610-1BB10-8AF0	6SL5510-1BB10-8AF0	12	3NW6006-1	J	15
			16	3NA3805	J	15
1	6SL5610-1BB11-0AF0	6SL5510-1BB11-0AF0	12	3NW6006-1	J	15
			16	3NA3805	J	15
Line voltage 380 ... 480 V 3 AC						
0.2	–	6SL5510-1BE10-2AF0	4	3NA3804 3NW6304-1	J J	3 3
0.4	–	6SL5510-1BE10-4AF0	4	3NA3804 3NW6304-1	J J	3 3
0.75	–	6SL5510-1BE10-8AF0	10	3NA3803 3NW6303-1	J J	10 10
1	–	6SL5510-1BE11-0AF0	10	3NA3803 3NW6303-1	J J	10 10
1.75	–	6SL5510-1BE11-5AF0	12	3NW6006-1	J	15
			16	3NA3805	J	15
2.5	–	6SL5510-1BE12-5AF0	16	3NA3805 3NW6305-1	J J	20 20
3.5	–	6SL5510-1BE13-5AF0	20	3NA3807 3NW6307-1	J J	25 25
5	–	6SL5510-1BE15-0AF0	20	3NA3807 3NW6007-1	J J	25 25
7	–	6SL5510-1BE17-0AF0	25	3NA3810 3NW6010-1	J J	25 25

Overview

If the internal braking resistor cannot meet the braking requirements, an external resistor must be used, which converts the regenerative electrical energy into heat and thus provides significantly improved braking and deceleration capabilities.

When selecting a braking resistor, factors such as load inertia, deceleration time, speed change and braking duration must be taken into account according to the specific application and technology.

Further information is available in the technical documentation on the Internet at:
www.siemens.com/sinamics-s200

SINAMICS S200 servo converters

Connecting cables for SIMATIC S7 controllers

Selection and ordering data

Description	Article No.
PROFINET I/O connector 20-pin	6SL3260-2MA00-0VA0
PROFINET I/O cable with 20-pin MDR connector, length: 1 m	6SL5562-1XX00-0AC0
PROFINET I/O adapter ¹⁾ for 20-pin MDR connector	6SL5562-1XX00-0AD0
Pre-assembled PROFINET cable with two RJ45 180° plugs, length: 1 m	6XV1871-5BH10
RJ45 data plug-in connector with 180° (straight) cable outlet	6GK1901-1BB10-2AA0
Standard PROFINET cable 4-core, sold by the meter, not assembled	6XV1840-2AH10
PROFINET patch cable For the networking of concatenated converters Industrial Ethernet TP cord, CAT 6 A, twisted pair line 4 × 2 cores, pre-assembled with two RJ45 connectors	
• 0.3 m (0.98 ft)	6XV1870-3QE30
• 0.5 m (1.64 ft)	6XV1870-3QE50

For further information about PROFINET cables refer on the internet at:

www.siemens.com/simatic-net

¹⁾ Available soon.

Overview



Sample memory card SINAMICS SD card

The parameter assignment, firmware and licenses for a converter can be stored on the SINAMICS SD memory card. When service is required, e.g. after the converter has been replaced and the data have been downloaded from the memory card the drive system is immediately ready for use again.

The memory card has the following functions:

- Parameter settings can be written from the memory card to the converter or saved from the converter to the memory card
- The memory card supports series commissioning without the use of a commissioning tool
- If firmware is stored on the memory card, the firmware can be upgraded/downgraded during startup

Notes:

In general, the converter can be operated without a memory card. However, it is necessary if licenses, such as the Extended Safety license, are required. The card must then remain permanently inserted.

Selection and ordering data

Description	Article No.
SINAMICS SD card 8 GB Parameter assignments, firmware and licenses for a converter can be stored on the memory card.	
<ul style="list-style-type: none"> • Empty • With firmware V6.2 	
	6SL5970-0AA00-0AA0 6SL5570-0GC00-0AA0

SINAMICS S200 servo converters

Spare parts

Shield connection kit

Selection and ordering data

Description	Article No.
Shield connection kit including several shield plates and fixing screws	6SL5566-0AB00-0AA0

Terminal kits

Selection and ordering data

Description	Article No.
Terminal kits	
• for SINAMICS S200	6SL5568-0XX00-0AA0
• for SINAMICS S200 Basic	6SL5668-0XX00-0AA0

Replacement fans

Selection and ordering data

Description	Article No.
Replacement fans	
• for SINAMICS S200, 400 V version, FSC	6SL5566-0CE00-0AA0
• for SINAMICS S200, 400 V version, FSD	6SL5566-0DE00-0AA0

SIMOTICS S-1FL2 servomotors for SINAMICS S200



3/2	Overview
3/2	Benefits
3/2	Application
3/3	Selection and ordering data
3/4	Technical specifications
3/4	General technical specifications
3/9	Shaft height 20
3/11	Shaft height 30
3/14	Shaft height 40
3/17	Shaft height 45
3/19	Shaft height 48
3/21	Shaft height 52
3/23	Shaft height 65
3/26	Shaft height 90

For **selection and ordering data** please also refer to section "System overview" "SINAMICS S200 servo drive system" from page 1/14.

Detailed technical information on the SINAMICS S200 servo drive system is available on the internet at:
www.siemens.com/sinamics-s200/documentation

In addition, the Siemens Product Configurator can be used on the internet at the following address:
www.siemens.com/sinamics-s200/configuration

SIMOTICS S-1FL2 servomotors for SINAMICS S200

Overview

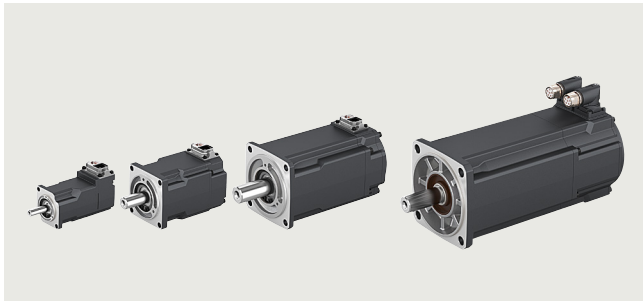

SIMOTICS S-1FL2 Low Inertia servomotors, shaft heights 20, 30, 40 and 52

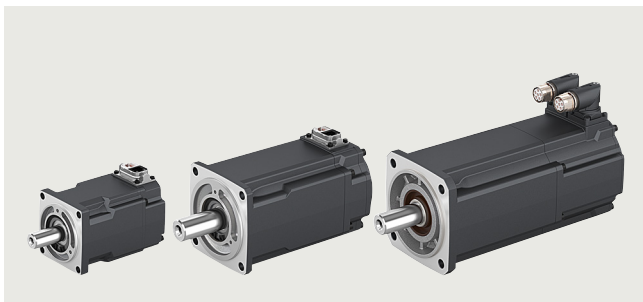

SIMOTICS S-1FL2 Medium Inertia servomotors, shaft heights 30, 40 and 48

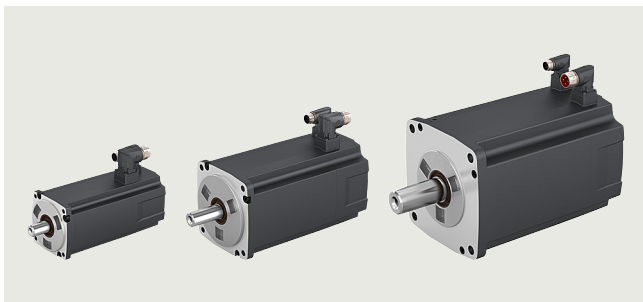

SIMOTICS S-1FL2 High Inertia servomotors, shaft heights 45, 65 and 90

The SIMOTICS S-1FL2 servomotors are compact and highly dynamic synchronous motors for a wide range of uses in an industrial environment. They are characterized by high power density, degree of protection and overload capability.

The 1FL2 servomotors are perfectly suited to overcome the essential challenges in servo drive technology. The product range includes a limited number of variants and options and therefore enables a simple overview and selection. They form the core of the servomotors for the SINAMICS S200 servo drive system.

SIMOTICS S-1FL2 Low Inertia motors

Highest dynamic response through low inertia for highly dynamic applications with low moved masses.

SIMOTICS S-1FL2 Medium Inertia motors

Precise, stable control with medium masses to be moved with medium moment of inertia.

SIMOTICS S-1FL2 High Inertia motors

Precise, stable control with high masses to be moved with high moment of inertia.

Benefits

The SIMOTICS S-1FL2 servomotors fully exploit their strengths in the system with the SINAMICS S200 converter:

- Short adjustment and positioning times
- Quick and precise compensation of disturbances
- Stable closed loop control with high dynamic response

This is achieved by:

- Rapid control cycle
- High pulse frequency
- Complex rule algorithms
- High-resolution optical encoder with fast scanning
- Low moment of inertia of the motors
- High overload capability

Application

- Packaging machines
- Handling equipment
- Feed and withdrawal devices
- Stacking units
- Automatic assembly machines
- Laboratory automation
- Woodworking, glass and ceramic industries

Selection and ordering data

Structure of the Article No. of the SIMOTICS S-1FL2 servomotors

Data position in Article No.	1	2	3	4	5	6	7	8	9	10	11	12	13	14	15	16			
	1	F	L	2	■	■	■	-	■	A	■	■	■	-	■	■	■	0	
1st to 4th position: digit, letter, letter, digit	Motor 1 F L 2																		
5th position: digit	Moment of inertia																		
	Low Inertia				1														
	Medium Inertia				2														
	High Inertia				3														
5th, 6th and 7th positions: digit, digit, digit	Shaft height																		
	20				1	0	2												
	30				1	0	3												
					2	0	3												
	40				1	0	4												
					2	0	4												
	45				3	0	4												
	48				2	0	5												
	52				1	0	5												
	65				3	0	6												
	90				3	1	0												
8th position: digit	Overall length See specific technical specifications							0 ... 8											
9th position: letter	Natural cooling								A										
10th position: letter	Winding/rated speed																		
	2000 rpm at 400 V									C									
	3000 rpm at 400 V									F									
	3000 rpm at 200 V									G									
11th position: digit	Brake																		
	Without										0								
	Holding brake										1								
12th position: digit	Degree of protection																		
	IP54											0							
	IP65 (with shaft sealing ring)											1							
13th position: digit	Shaft extension, feather key																		
	Plain shaft													0					
	Shaft with feather key (half-key balancing)													1					
14th position: letter	Encoder																		
	Absolute encoder 17-bit singleturn																	H	
	Absolute encoder 21-bit singleturn																	S	
	Absolute encoder 21-bit singleturn + 12-bit multiturn																	M	
15th position: letter	Connection technology																		
	Metal circular connector																	B	
	Metal hybrid connector																	C	
16th position: digit	Reserved																		0

SIMOTICS S-1FL2 servomotors for SINAMICS S200

Technical specifications

General technical specifications

SIMOTICS S-1FL2 motors – Low Inertia/Medium Inertia/High Inertia	
Motor type	Permanent-magnet synchronous motor
Permissible operating conditions	
<ul style="list-style-type: none"> Ambient temperature 	-15 ... +40 °C (5 ... 104 °F) without derating -15 ... +60 °C (5 ... 140 °F) with derating For more derating information, see operating instructions online at: www.siemens.com/sinamics-s200/documentation
<ul style="list-style-type: none"> Installation altitude, max. 	1000 m (3281 ft) without derating > 1000 m ... 5000 m (> 3281 ft ... 16405 ft) with derating For more derating information, see operating instructions online at: www.siemens.com/sinamics-s200/documentation
Relative humidity	90% at 30 °C (86 °F) (no condensation)
Degree of protection	
According to EN 60034-5 (IEC 60034-5) <ul style="list-style-type: none"> 1FL2102, 1FL2.03, 1FL2104 and 1FL2204 	IP54 for the shaft extension (without shaft sealing ring) and IP65 for the motor body, optionally IP65 for the whole motor (with shaft sealing ring)
<ul style="list-style-type: none"> 1FL2.05 and 1FL23.. 	IP65 (with shaft sealing ring)
Cooling	Natural cooling (IC410)
According to EN 60034-6	
Type of construction	IM B5 (IM V1, IM V3)
According to EN 60034-7 (IEC 60034-7)	
Shaft extension	Plain shaft
According to DIN 748-3 (IEC 60072-1)	Optional shaft with feather key (half-key balancing)
Shaft and flange accuracy	Tolerance N
According to DIN 42955 (IEC 60072-1)	In each case for radial eccentricity of the shaft extension, concentricity of the centering ring, and axial eccentricity of the mounting flange to the axis of the shaft extension.
Vibration severity grade	Grade A
According to EN 60034-14 (IEC 60034-14)	is maintained up to rated speed
Stator winding insulation	
According to EN 60034-1 (IEC 60034-1) <ul style="list-style-type: none"> 1FL2102, 1FL2.03 and 1FL23.. 	Thermal class 130 (B) for a winding overtemperature of $\Delta T = 80$ K
<ul style="list-style-type: none"> 1FL2104, 1FL2204, 1FL2105 and 1FL2205 	Thermal class 155 (F) for a winding overtemperature of $\Delta T = 100$ K
Sound pressure level L_{pA} (1 m), max.	
According to ISO 1680 <ul style="list-style-type: none"> 1FL2102, 1FL2.03, 1FL2104 and 1FL2204 	60 dB(A) +3 dB(A) tolerance
<ul style="list-style-type: none"> 1FL2.05 and 1FL2304 	65 dB(A) +3 dB(A) tolerance
<ul style="list-style-type: none"> 1FL2306 and 1FL2310 	70 dB(A) +3 dB(A) tolerance
Encoder system	<ul style="list-style-type: none"> Absolute encoder 17-bit singleturn Absolute encoder 21-bit singleturn Absolute encoder 21-bit singleturn + 12-bit multiturn
Holding brake	Optional integrated holding brake
Connection	
<ul style="list-style-type: none"> 1FL2102, 1FL2.03, 1FL2104 and 1FL2204 	Double line with a metal hybrid connector
<ul style="list-style-type: none"> 1FL2.05 	Two cable connections with two metal circular connectors
<ul style="list-style-type: none"> 1FL23.. 	Three cable connections with three metal circular connectors
Paint finish	RAL 7016 (anthracite gray)
Certificates of suitability	CE, UKCA, cURus, EAC

Technical specifications

Regulations, standards, specifications

The motors comply with the appropriate standards and regulations, see table below.

As a result of the fact that in many countries the national regulations have been completely harmonized with the international IEC 60034-1 recommendation, there are no longer any differences with respect to coolant temperatures, temperature classes and temperature rise limits.

General specifications for rotating electrical machines	IEC 60034-1
Terminal designations and direction of rotation for electrical machines	IEC 60034-8
Types of construction of rotating electrical machines	IEC 60034-7
Cooling methods of rotating electrical machines	IEC 60034-6
Degrees of protection of rotating electrical machines	IEC 60034-5
Vibration severity of rotating electrical machines	IEC 60034-14
Noise limit values for rotating electrical machines	IEC 60034-9
Cylindrical shaft extensions for electrical machines	DIN 748-3/IEC 60072-1



SIMOTICS S-1FL2 motors have UL approval from Underwriters Laboratories Inc. and are marked with the "UL Recognized Component" test symbol.

This is used for components which are part of a larger product or system. This confirmed compliance with the corresponding US American and Canadian regulations, and allowed access to the North American market.



For SIMOTICS S-1FL2 motors, conformity with the relevant EC Directives 2006/95/EC and 2014/35/EU and the relevant standards

EN 60034-1:2010, EN 60204-1:2006 is confirmed. By applying the CE mark to the product, Siemens AG confirms this for the product, and secures the free movement of goods within the European Union..



The UKCA (UK Conformity Assessed) marking is a new product marking that will be used for products being placed on the market in Great Britain (England, Wales and Scotland). It covers most

products which previously required a CE marking.

The UKCA marking is mandatory for deliveries to the UK starting January 1, 2023.

The marking is typically applied to motors with a second nameplate bearing the UKCA label.

Degree of protection acc. to IEC 60034-5

A suitable degree of protection must be selected according to the operating and environmental conditions to protect the motor against damage caused by the ingress of water and other liquids, as well as dust and foreign bodies.

SIMOTICS S-1FL2 motors in the 1FL2102, 1FL2.03, 1FL2104 and 1FL2204 versions are produced with the IP54 degree of protection as standard (no shaft sealing ring) and in IP65 for the motor body, optionally in IP65 for the entire motor (with shaft sealing ring).

SIMOTICS S-1FL2 motors in the 1FL2.05 and 1FL23.. versions are produced as standard with a radial shaft seal ring in degree of protection IP65. This increases the protection against the ingress of liquids.

The degree of protection designation is composed from the code IP (for International Protection) and two code numbers for the protection against touching and penetration of foreign bodies, and the degree of protection against the ingress of water.

First code number

6: Protection against dust ingress and complete protection against touching

Second code number

4: Protection against splashwater from any direction

5: Protection against jet water from any direction

Recommended degrees of protection for three-phase motors

When cooling lubricants are used, protection against water alone is inadequate. The IP rating should only be considered as a guide value in this case. The motors may have to be protected by suitable covers. Attention must be paid to providing suitable sealing of the motor shaft for the selected degree of protection for the motor.

The following table can serve as a decision aid for selecting the proper degree of protection for motors. A permanent covering of liquid on the flange must be avoided when the motor is mounted with the shaft extension facing upwards (IM V3).

Effect	General workshop environment	Water/ general cooling lubricant (95 % water, 5 % oil)
Dry	IP64	-
Humid/moist environment	-	IP64
Mis	-	IP65
Spraying water	-	IP65

SIMOTICS S-1FL2 servomotors for SINAMICS S200

Technical specifications

Type of construction, mounting position according to IEC 60034-7

SIMOTICS S-1FL2 motors are designed in type of construction IM B5. They may also be used in mounting positions IM V1 and IM V3.

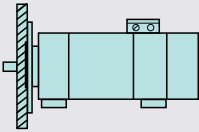
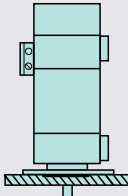
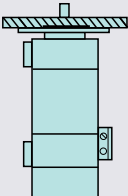
Code 1	IM B5	IM V1	IM V3
Code 2	IM 3001	IM 3011	IM 3031
			
	Horizontal flange mounting	Flange mounting, output shaft pointing vertically downwards	Flange mounting, output shaft pointing vertically upwards

Shaft and flange accuracy in accordance with IEC 60072-1

Radial eccentricity tolerance of shaft in relation to housing axis (referred to cylindrical shaft extensions)

Motor	Shaft extension D × L mm (in)	Radial eccentricity tolerance N µm
1FL2102	8 × 25 (0.31 × 0.98)	30
1FL2.03	14 × 30 (0.55 × 1.18)	35
1FL2104	19 × 40 (0.75 × 1.57)	40
1FL2204		
1FL2105	19 × 45 (0.75 × 1.77)	
1FL2205	19 × 40 (0.75 × 1.57)	
1FL2304	19 × 35 (0.75 × 1.38)	
1FL2306	22 × 58 (0.87 × 2.28)	
1FL2310	35 × 80 (1.38 × 3.15)	50

Concentricity and axial eccentricity tolerance of the flange surface for the shaft axis

(referred to the centering diameter of the mounting flange)

Motor	Centering diameter mm (in)	Concentricity and axial eccentricity Tolerance N µm
1FL2102	30 (1.18)	60
1FL2.03	50 (1.97)	80
1FL2104	70 (2.76)	
1FL2204		
1FL2105	95 (3.74)	
1FL2205	80 (3.15)	
1FL2304	80 (3.15)	
1FL2306	110 (4.33)	100
1FL2310	114.3 (4.50)	

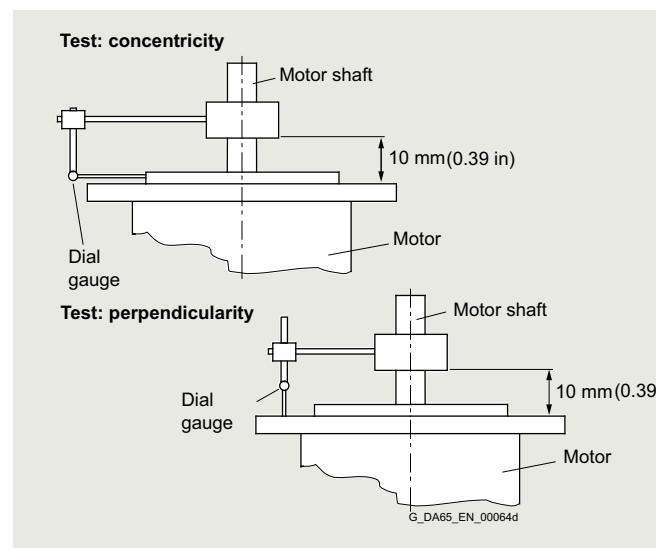
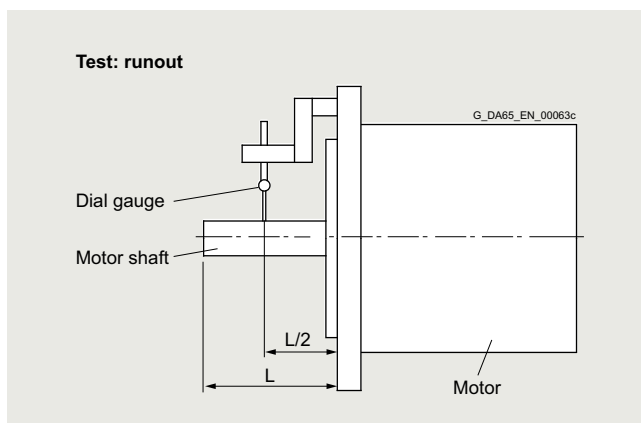

Technical specifications

Vibration severity and vibration severity grade A according to IEC 60034-14

The vibration severity is the RMS value of the vibration velocity (frequency range from 10 Hz to 2000 Hz). The vibration severity is measured using electrical measuring devices according to DIN 45666.

The specified values refer only to the motor. These values can increase as a result of the overall system vibrational behavior due to installation.

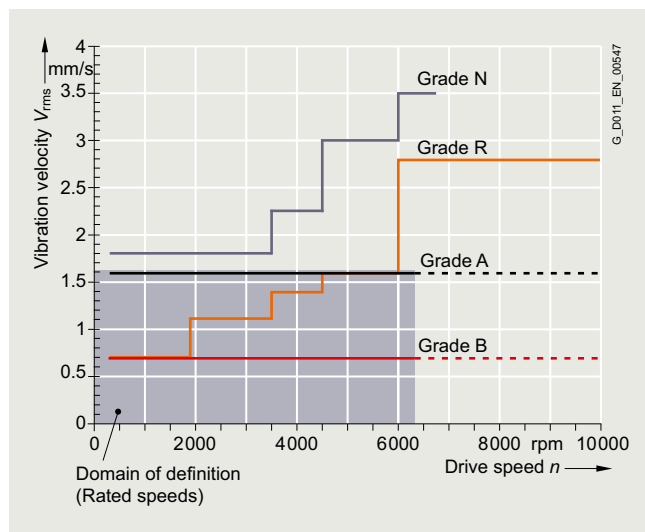

Vibration severity limit values

The speeds of 1800 rpm and 3600 rpm and the associated limit values are specified according to IEC 60034-14.

The speeds of 4500 rpm and 6000 rpm and the specified values are defined by the motor manufacturer.

The motors maintain vibration severity grade A up to the rated speed.

Balancing according to ISO 21940-32

Apart from the balance quality of the motor, the vibrational quality of motors with attached belt pulleys is mainly determined by the balance state of the mounted component. If the motor and the mounted component are balanced separately before being joined, the balancing process of the belt pulley is to be adapted to the motor's balancing type.

SIMOTICS S-1FL2 motors with feather keys are always half-key balanced. In general, motors with a plain shaft are recommended for systems with the most stringent vibrational quality requirements.

Vibration stress, immitted vibration values

The requirements of environmental class 3M8 (according to EN 60721-3-3 Table 6) must be maintained for proper function and safeguard the bearing life. The following limits are valid for (immitted) vibration values introduced into the motor from outside:

- For Low Inertia and Medium Inertia:
 - Vibration velocity V_{rms} according to ISO 10816, max. 4.5 mm/s (0.18 in/s)
 - Vibration acceleration a_{peak} axial and radial 50 m/s² (164 ft/s²)
- For High Inertia:
 - Vibration velocity V_{rms} according to ISO 10816, max. 4.5 mm/s (0.18 in/s)
 - Vibration acceleration a_{peak} axial 25 m/s² (82 ft/s²) and a_{peak} radial 50 m/s² (164 ft/s²)

During transport, the motors withstand single shocks (6 ms) of up to 250 m/s² (820 ft/s²).

Ambient temperature and installation altitude

Operating range without restrictions:

Temperature range from -15 °C to +40 °C (5 °F to 104 °F), installation altitude up to 1000 m (3281 ft).

If deviating conditions are encountered, the S1 characteristic of the motor must be adapted with regard to speed and torque.

Use the following equation to calculate the reduced S1 characteristic:

$$S1_{red}(n) = x_D \times S1_{40\text{ °C}(104\text{ °F}); 1000\text{ m}(3281\text{ ft})}(n/x_D)$$

Installation altitude above sea level m (ft)	Derating factor x_D at an ambient temperature of			
	30 °C (86 °F)	40 °C (104 °F)	45 °C (113 °F)	50 °C (122 °F)
1000 (3281)	1.08	1.00	0.96	0.91
2000 (6562)	1.02	0.93	0.89	0.84
3000 (9843)	0.95	0.86	0.81	0.75
4000 (13124)	0.88	0.77	0.72	0.66
5000 (16405)	0.80	0.68	0.62	0.55

Encoder systems

Singleturn absolute encoder

This encoder outputs an absolute angular position between 0° and 360° in the specified resolution. In contrast to the multiturn absolute encoder, it does not have a revolution counter, and can therefore only supply the position value within one revolution. It does not have a traversing range.

Multiturn absolute encoder

This encoder outputs an absolute angular position between 0° and 360° in the specified resolution. It can also count 4096 revolutions. So with a ball screw, for example, the absolute position of the slide can be determined over a longer distance.

14th position in the Article No. of the motor	Designation
1FL2-H..	Absolute encoder 17-bit singleturn (resolution 131072)
1FL2-S..	Absolute encoder 21-bit singleturn (resolution 2097152)
1FL2-M..	Absolute encoder 21-bit singleturn + 12-bit multiturn (resolution 2097152, traversing range 4096 revolutions)

SIMOTICS S-1FL2 servomotors for SINAMICS S200

Technical specifications

Holding brake

Many drives need a holding brake with an EMERGENCY STOP function for safety reasons or to meet process requirements. The brakes used on SIMOTICS S-1FL2 motors operate on the quiescent current principle. A spring or permanent magnet exerts a tensile force on the brake armature disk, i.e. in a state of zero current, the brake is closed and the motor shaft thereby stopped.

An electric current that flows through a coil generates an opposing field that counteracts the force effect of the spring or permanent magnet and releases or holds open the brake. Only a limited number of braking operations can be performed for an EMERGENCY STOP or power failure without causing excessive wear on the holding brake. The holding brake is not an operational brake. Regular dynamic braking leads to increased wear and premature brake failure. In order to ensure the functionality and specification of the brake, neither the total

operating energy nor the maximum switching energy per braking operation may be exceeded.

The brake control is already fully integrated into the SINAMICS S200 converter system, so that an external circuit is not necessary.

After an EMERGENCY STOP sequence with the maximum single switching energy, a cooling time of at least 3 minutes is required.

The following table contains technical specifications of the holding brakes for operating on SINAMICS S200 converters.

Motor	Shaft height	Holding torque	Dynamic braking torque	Opening time	Closing time	Maximum permissible single switching energy	Total operating energy (service life)	Holding current
		Nm (lbf-ft)	Nm (lbf-ft)	ms	ms	J	kJ	A
1FL2102	20	0.32 (0.24)	0.32 (0.24)	35	10	1	2	< 1
1FL2.03	30	1.3 (0.96)	1.3 (0.96)	60	10	10	20	< 1
1FL2104 1FL2204	40	3.3 (2.43)	3.3 (2.43)	100	15	43	86	< 1
1FL2105	52	8 (5.90)	5 (3.69)	90	25	142	284	< 1
1FL2205	48	8 (5.90)	5 (3.69)	90	25	142	284	< 1
1FL2304	45	3.5 (2.58)	3.5 (2.58)	60	45	140	280	< 2
1FL2306	65	12 (8.85)	12 (8.85)	180	60	600	1200	< 2
1FL2310	90	30 (22.1)	30 (22.1)	220	115	1100	2200	< 2

¹⁾ Typische Werte bei einer Umgebungstemperatur von 20 °C.
Bei -15 °C können sich die Öffnungsströme um bis zu 30 % erhöhen.

Technical specifications

SIMOTICS S-1FL2 shaft height 20

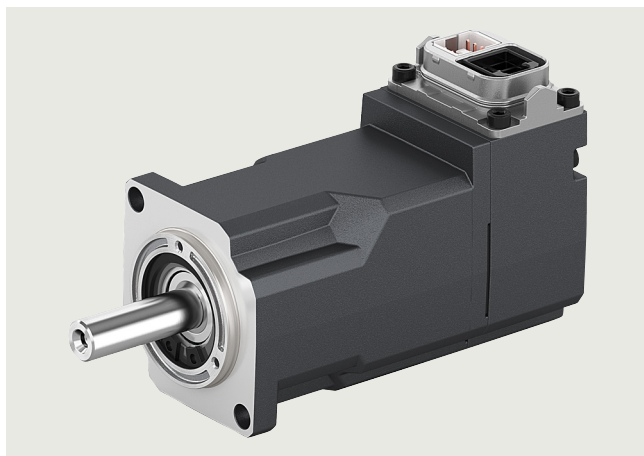

Specific technical specifications

SIMOTICS S-1FL2 servomotors		Low Inertia			
Shaft height 20		1FL2102-2AG	1FL2102-2AF	1FL2102-4AG	1FL2102-4AF
Static torque M_0	Nm (lb _f -ft)	0.16 (0.12)	0.16 (0.12)	0.32 (0.24)	0.32 (0.24)
Stall current I_0	A	0.81	0.84	0.76	0.81
Maximum torque M_{max}	Nm (lb _f -ft)	0.56 (0.41)	0.56 (0.41)	1.12 (0.83)	1.12 (0.83)
Maximum current I_{max}	A	3.1	3.4	2.95	2.9
Maximum speed n_{max}	rpm	6500	6500	6500	6500
Rotor moment of inertia J_{Mot}	kg cm ² (lb _f -in ²)	0.017 (0.01)	0.017 (0.01)	0.029 (0.01)	0.029 (0.01)
Moment of inertia (with brake) $J_{Mot Br}$	kg cm ² (lb _f -in ²)	0.022 (0.01)	0.022 (0.01)	0.034 (0.01)	0.034 (0.01)
Weight m_{Mot}	kg (lb)	0.29 (0.64)	0.29 (0.64)	0.39 (0.86)	0.38 (0.84)
Weight (with brake) $m_{Mot Br}$	kg (lb)	0.46 (1.01)	0.45 (0.99)	0.56 (1.23)	0.55 (1.21)
200 ... 240 V 1 AC / 3 AC					
Rated speed n_N	rpm	3000	–	3000	–
Rated torque M_N	Nm (lb _f -ft)	0.16 (0.12)	–	0.32 (0.24)	–
Rated current I_N	A	0.81	–	0.76	–
Rated power P_N	W	50	–	100	–
380 ... 480 V 3 AC					
Rated speed n_N	rpm	–	3000	–	3000
Rated torque M_N	Nm (lb _f -ft)	–	0.16 (0.12)	–	0.32 (0.24)
Rated current I_N	A	–	0.84	–	0.81
Rated power P_N	W	–	50	–	100
Suitable for SINAMICS S200 Basic servo converters					
• 200 ... 240 V 1 AC		6SL5610-1BB10-1AF0	–	6SL5610-1BB10-1AF0	–
• 200 ... 240 V 3 AC		6SL5610-1BB10-1AF0	–	6SL5610-1BB10-1AF0	–
Suitable for SINAMICS S200 servo converters					
• 200 ... 240 V 1 AC		6SL5510-1BB10-1AF0	–	6SL5510-1BB10-1AF0	–
• 200 ... 240 V 3 AC		6SL5510-1BB10-1AF0	–	6SL5510-1BB10-1AF0	–
• 380 ... 480 V 3 AC		–	6SL5510-1BE10-2AF0	–	6SL5510-1BE10-2AF0

SIMOTICS S-1FL2 servomotors for SINAMICS S200

SIMOTICS S-1FL2 shaft height 20

Technical specifications

Dimensional drawing

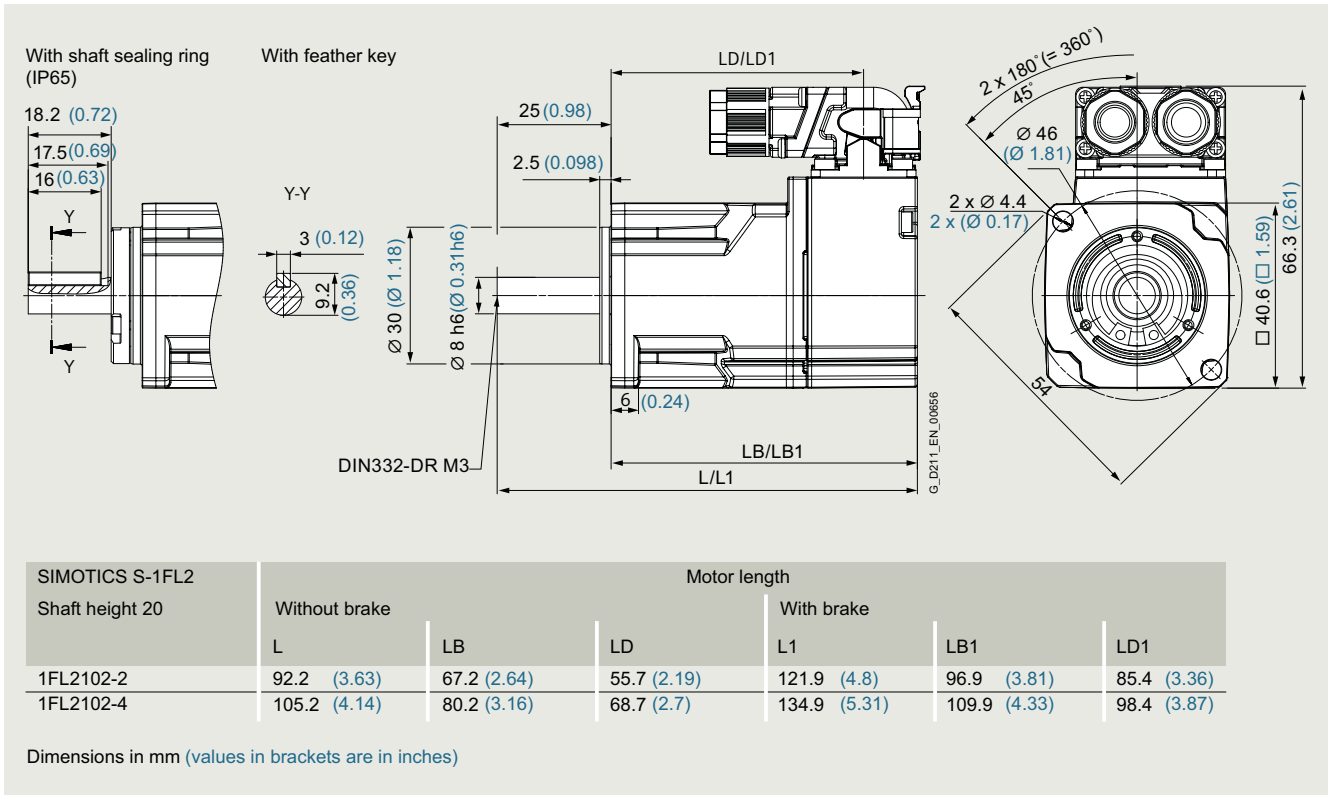

Speed/torque characteristics

Low Inertia

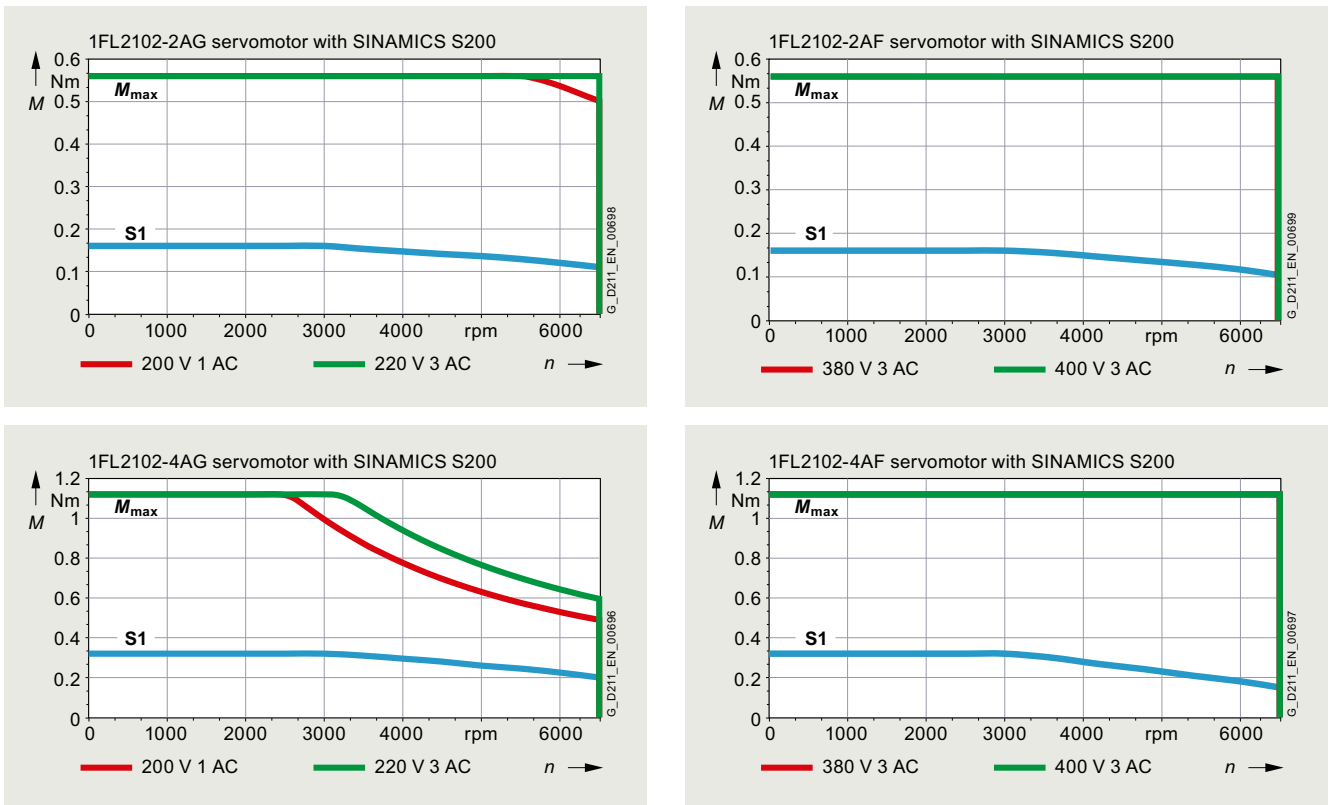

Technische Daten

SIMOTICS S-1FL2 shaft height 30

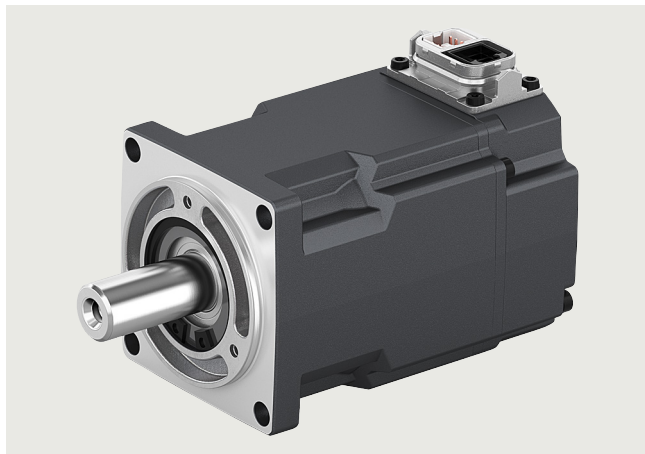

Specific technical specifications

SIMOTICS S-1FL2 servomotors		Low Inertia				Medium Inertia			
Shaft height 30		1FL2103-2AG	1FL2103-2AF	1FL2103-4AG	1FL2103-4AF	1FL2203-2AG	1FL2203-2AF	1FL2203-4AG	1FL2203-4AF
Static torque M_0	Nm (lb _f -ft)	0.64 (0.47)	0.64 (0.47)	1.27 (0.94)	1.27 (0.94)	0.64 (0.47)	0.64 (0.47)	1.27 (0.94)	1.27 (0.94)
Stall current I_0	A	1.28	1.3	2.4	1.3	1.33	1.3	2.4	1.3
Maximum torque M_{max}	Nm (lb _f -ft)	2.24 (1.65)	2.24 (1.65)	4.45 (3.28)	4.45 (3.28)	2.24 (1.65)	2.24 (1.65)	4.45 (3.28)	4.45 (3.28)
Maximum current I_{max}	A	4.8	4.8	8.7	4.8	4.8	4.8	8.7	4.8
Maximum speed n_{max}	rpm	6500	6500	6500	6500	6500	6500	6500	6500
Rotor moment of inertia J_{Mot}	kg cm ² (lb _f -in ²)	0.08 (0.03)	0.08 (0.03)	0.155 (0.05)	0.155 (0.05)	0.18 (0.06)	0.18 (0.06)	0.35 (0.12)	0.35 (0.12)
Moment of inertia (with brake) $J_{Mot Br}$	kg cm ² (lb _f -in ²)	0.11 (0.04)	0.11 (0.04)	0.185 (0.06)	0.185 (0.06)	0.21 (0.07)	0.21 (0.07)	0.38 (0.13)	0.38 (0.13)
Weight m_{Mot}	kg (lb)	0.79 (1.74)	0.78 (1.72)	1.16 (2.56)	1.14 (2.51)	0.76 (1.68)	0.77 (1.70)	1.11 (2.45)	1.09 (2.40)
Weight (with brake) $m_{Mot Br}$	kg (lb)	1.14 (2.51)	1.12 (2.47)	1.5 (3.31)	1.49 (3.29)	1.11 (2.45)	1.12 (2.47)	1.46 (3.22)	1.44 (3.18)
200 ... 240 V 1 AC / 3 AC									
Rated speed n_N	rpm	3000	–	3000	–	3000	–	3000	–
Rated torque M_N	Nm (lb _f -ft)	0.64 (0.47)	–	1.27 (0.94)	–	0.64 (0.47)	–	1.27 (0.94)	–
Rated current I_N	A	1.28	–	2.4	–	1.33	–	2.4	–
Rated power P_N	W	200	–	400	–	200	–	400	–
380 ... 480 V 3 AC									
Rated speed n_N	rpm	–	3000	–	3000	–	3000	–	3000
Rated torque M_N	Nm (lb _f -ft)	–	0.64 (0.47)	–	1.27 (0.94)	–	0.64 (0.47)	–	1.27 (0.94)
Rated current I_N	A	–	1.3	–	1.3	–	1.3	–	1.3
Rated power P_N	W	–	200	–	400	–	200	–	400
Suitable for SINAMICS S200 Basic servo converters									
• 200 ... 240 V 1 AC		6SL5610-1BB10-2AF0	–	6SL5610-1BB10-4AF0	–	6SL5610-1BB10-2AF0	–	6SL5610-1BB10-4AF0	–
• 200 ... 240 V 3 AC		6SL5610-1BB10-2AF0	–	6SL5610-1BB10-4AF0	–	6SL5610-1BB10-2AF0	–	6SL5610-1BB10-4AF0	–
Suitable for SINAMICS S200 servo converters									
• 200 ... 240 V 1 AC		6SL5510-1BB10-2AF0	–	6SL5510-1BB10-4AF0	–	6SL5510-1BB10-2AF0	–	6SL5510-1BB10-4AF0	–
• 200 ... 240 V 3 AC		6SL5510-1BB10-2AF0	–	6SL5510-1BB10-4AF0	–	6SL5510-1BB10-2AF0	–	6SL5510-1BB10-4AF0	–
• 380 ... 480 V 3 AC		–	6SL5510-1BE10-2AF0	–	6SL5510-1BE10-4AF0	–	6SL5510-1BE10-2AF0	–	6SL5510-1BE10-4AF0

SIMOTICS S-1FL2 servomotors for SINAMICS S200

SIMOTICS S-1FL2 shaft height 30

Technical specifications

Dimensional drawing

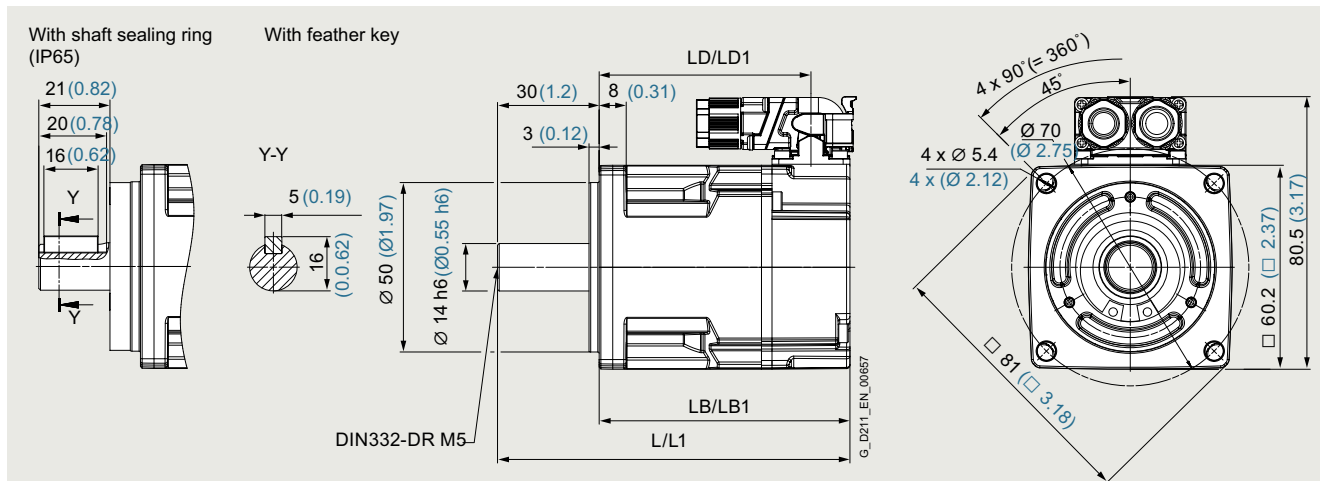

SIMOTICS S-1FL2 Shaft height 30	Motor length					
	Without brake			With brake		
	L	LB	LD	L1	LB1	LD1
1FL2103-2	105.5 (4.15)	75.5 (2.97)	63.8 (2.51)	135.5 (5.33)	105.5 (4.15)	93.8 (3.69)
1FL2103-4	124.5 (4.90)	94.5 (3.72)	82.8 (3.26)	154.5 (6.08)	124.5 (4.90)	112.8 (4.44)
1FL2203-2	104 (4.09)	74 (2.91)	62.3 (2.45)	134 (5.27)	104 (4.09)	92.3 (3.63)
1FL2203-4	121.5 (4.78)	91.5 (3.6)	79.8 (3.14)	151.5 (5.96)	121.5 (4.78)	109.8 (4.32)

Dimensions in mm (values in brackets are in inches)

Speed/torque characteristics

Low Inertia

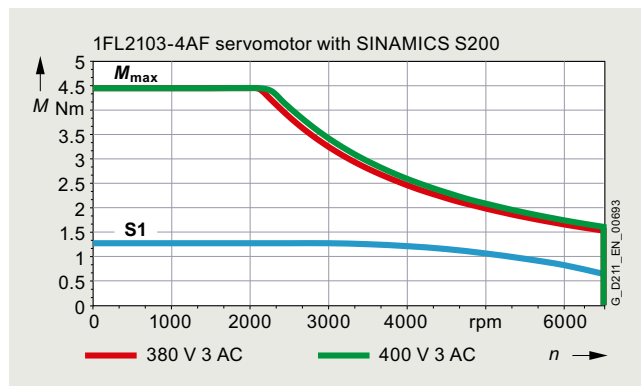
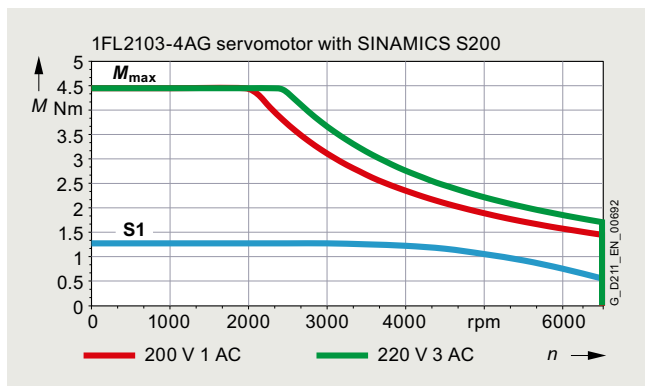
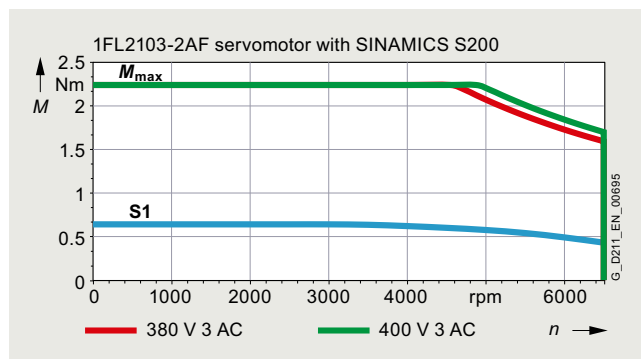
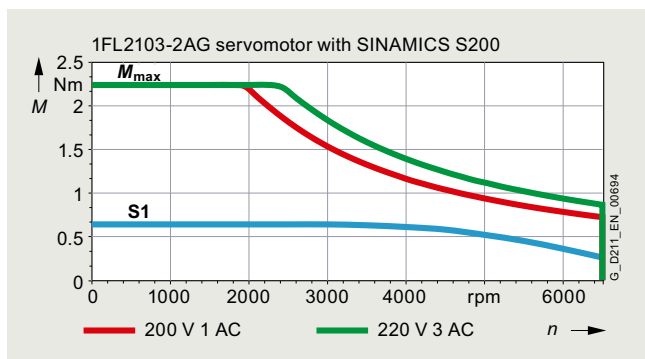

Technische Daten

Medium Inertia

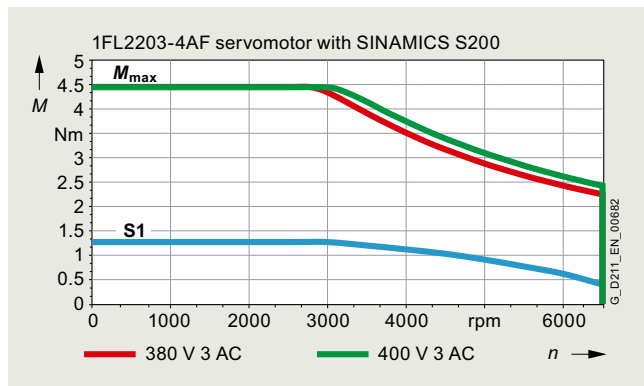
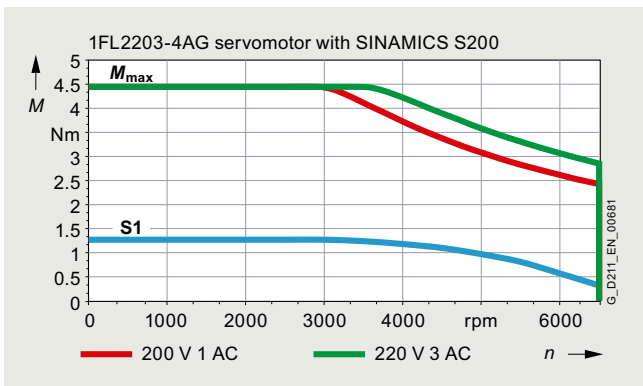
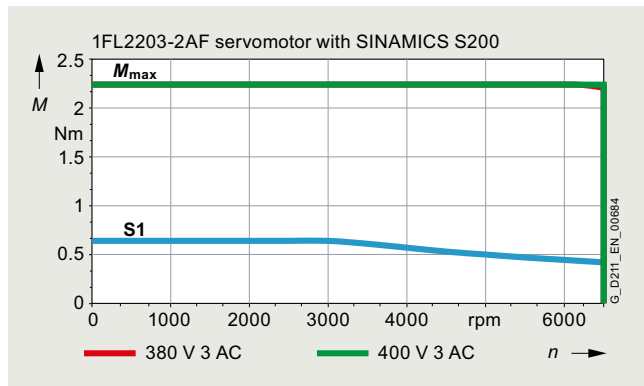
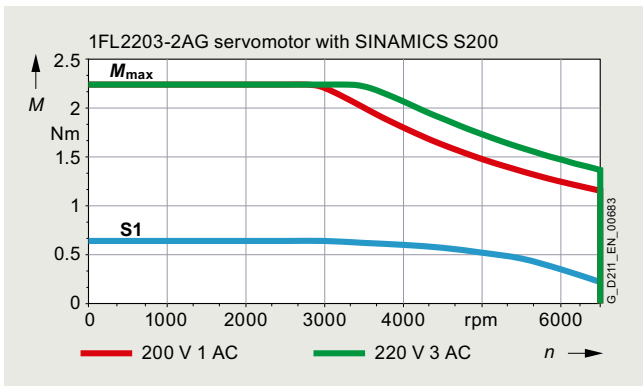

3

SIMOTICS S-1FL2 servomotors for SINAMICS S200

SIMOTICS S-1FL2 shaft height 40

Technical specifications

SIMOTICS S-1FL2 shaft height 40

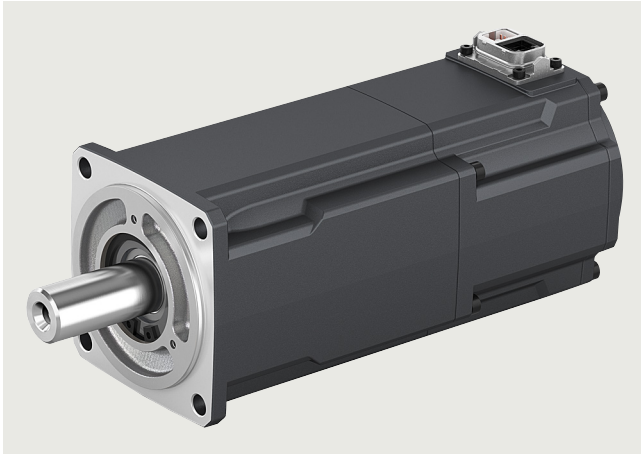

Specific technical specifications

SIMOTICS S-1FL2 servomotors		Low Inertia				Medium Inertia			
Shaft height 40		1FL2104-2AG	1FL2104-2AF	1FL2104-4AG	1FL2104-4AF	1FL2204-2AG	1FL2204-2AF	1FL2204-4AG	1FL2204-4AF
Static torque M_0	Nm (lb _f -ft)	2.4 (1.77)	2.4 (1.77)	3.2 (2.36)	3.2 (2.36)	2.4 (1.77)	2.4 (1.77)	3.2 (2.36)	3.2 (2.36)
Stall current I_0	A	4.4	2.1	4.4	3	4.4	2.25	4.4	3
Maximum torque M_{max}	Nm (lb _f -ft)	8 (5.90)	8 (5.90)	10.8 (7.97)	10.8 (7.97)	7.5 (5.53)	7.5 (5.53)	11.3 (8.33)	10 (7.38)
Maximum current I_{max}	A	16	7.6	16	10.9	14.2	7.1	16	9.9
Maximum speed n_{max}	rpm	6500	6500	6500	6500	6500	6500	6500	6500
Rotor moment of inertia J_{Mot}	kg cm ² (lb _f -in ²)	0.5 (0.17)	0.5 (0.17)	0.63 (0.22)	0.63 (0.22)	1.23 (0.42)	1.23 (0.42)	1.61 (0.55)	1.61 (0.55)
Moment of inertia (with brake) $J_{Mot Br}$	kg cm ² (lb _f -in ²)	0.58 (0.20)	0.58 (0.20)	0.71 (0.24)	0.71 (0.24)	1.31 (0.45)	1.31 (0.45)	1.69 (0.58)	1.69 (0.58)
Weight m_{Mot}	kg (lb)	2.7 (5.95)	2.7 (5.95)	3.3 (7.28)	3.3 (7.28)	2.6 (5.73)	2.6 (5.73)	3.1 (6.84)	3.1 (6.84)
Weight (with brake) $m_{Mot Br}$	kg (lb)	3.5 (7.72)	3.5 (7.72)	4.1 (9.04)	4.1 (9.04)	3.4 (7.50)	3.4 (7.50)	3.9 (8.60)	3.9 (8.60)
200 ... 240 V 1 AC / 3 AC									
Rated speed n_N	rpm	3000	–	3000	–	3000	–	3000	–
Rated torque M_N	Nm (lb _f -ft)	2.4 (1.77)	–	3.2 (2.36)	–	2.4 (1.77)	–	3.2 (2.36)	–
Rated current I_N	A	4.4	–	4.4	–	4.4	–	4.4	–
Rated power P_N	W	750	–	1000	–	750	–	1000	–
380 ... 480 V 3 AC									
Rated speed n_N	rpm	–	3000	–	3000	–	3000	–	3000
Rated torque M_N	Nm (lb _f -ft)	–	2.4 (1.77)	–	3.2 (2.36)	–	2.4 (1.77)	–	3.2 (2.36)
Rated current I_N	A	–	2.1	–	3	–	2.25	–	3
Rated power P_N	W	–	750	–	1000	–	750	–	1000
Suitable for SINAMICS S200 Basic servo converters									
• 200 ... 240 V 1 AC		6SL5610-1BB10-8AFO	–	6SL5610-1BB11-0AFO	–	6SL5610-1BB10-8AFO	–	6SL5610-1BB11-0AFO	–
• 200 ... 240 V 3 AC		6SL5610-1BB10-8AFO	–	6SL5610-1BB11-0AFO	–	6SL5610-1BB10-8AFO	–	6SL5610-1BB11-0AFO	–
Suitable for SINAMICS S200 servo converters									
• 200 ... 240 V 1 AC		6SL5510-1BB10-8AFO	–	6SL5510-1BB11-0AFO	–	6SL5510-1BB10-8AFO	–	6SL5510-1BB11-0AFO	–
• 200 ... 240 V 3 AC		6SL5510-1BB10-8AFO	–	6SL5510-1BB11-0AFO	–	6SL5510-1BB10-8AFO	–	6SL5510-1BB11-0AFO	–
• 380 ... 480 V 3 AC		–	6SL5510-1BE10-8AFO	–	6SL5510-1BE11-0AFO	–	6SL5510-1BE10-8AFO	–	6SL5510-1BE11-0AFO

Technical specifications

Dimensional drawing

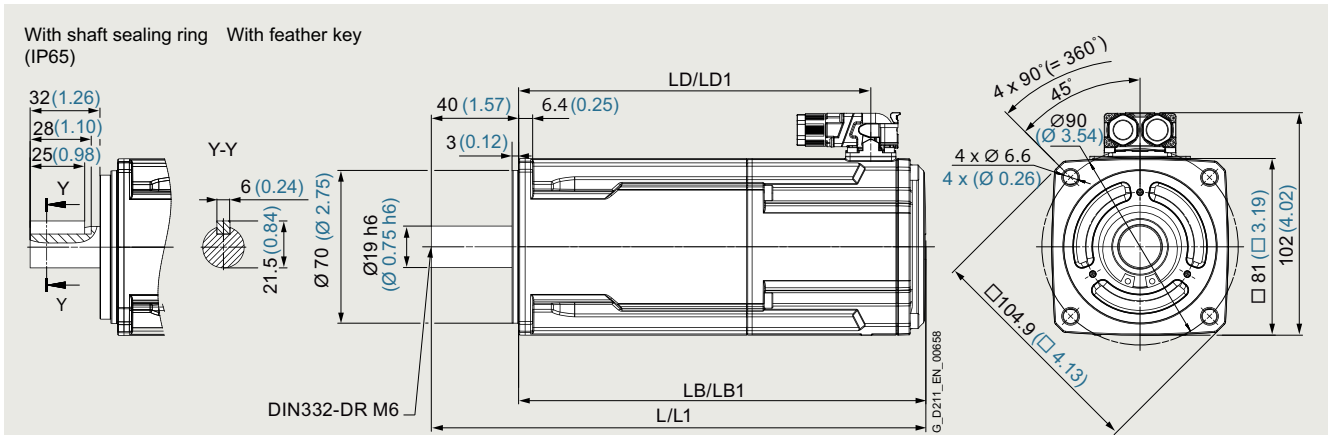

SIMOTICS S-1FL2 Shaft height 40	Motor length					
	Without brake			With brake		
	L	LB	LD	L1	LB1	LD1
1FL2104-2	164.6 (6.48)	124.6 (4.91)	99.4 (2.51)	208.6 (8.21)	168.6 (6.64)	143.4 (5.65)
1FL2204-2						
1FL2104-4	182.6 (7.19)	142.6 (5.61)	117.4 (4.62)	226.6 (8.92)	186.6 (7.35)	161.4 (6.35)
1FL2204-4						

Dimensions in mm (values in brackets are in inches)

Speed/torque characteristics

Low Inertia

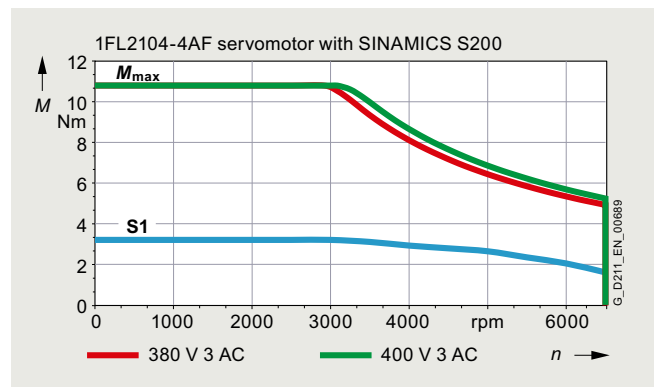
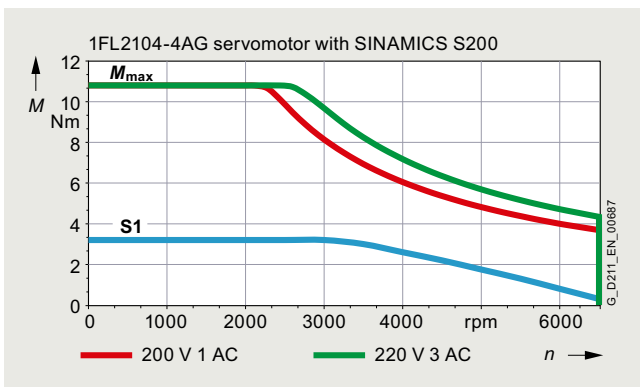
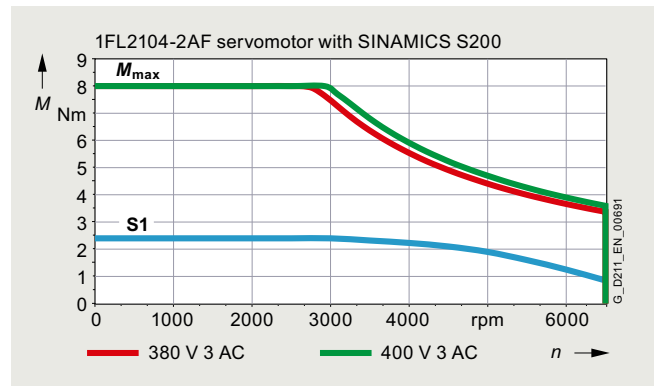
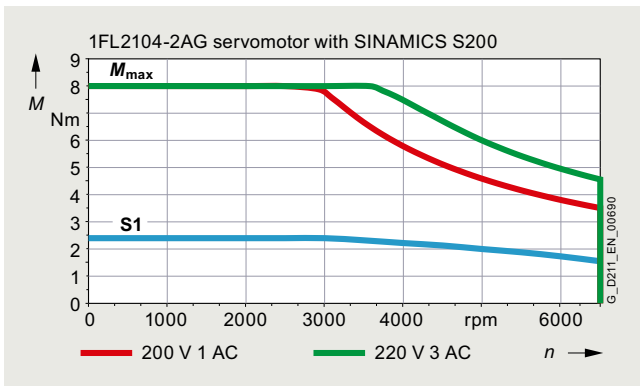

SIMOTICS S-1FL2 servomotors for SINAMICS S200

SIMOTICS S-1FL2 shaft height 40

Technical specifications

Medium Inertia

3

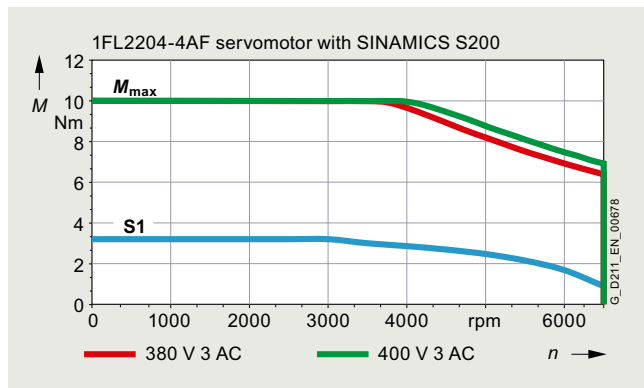
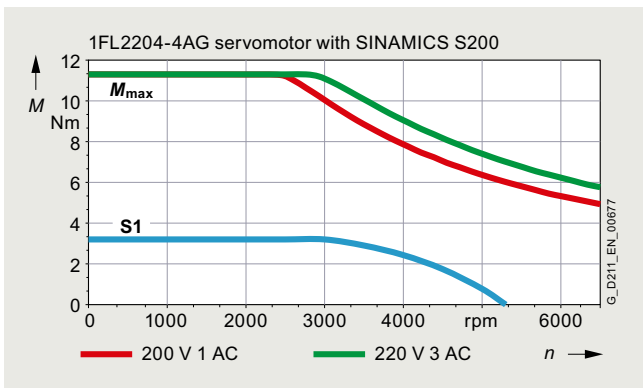
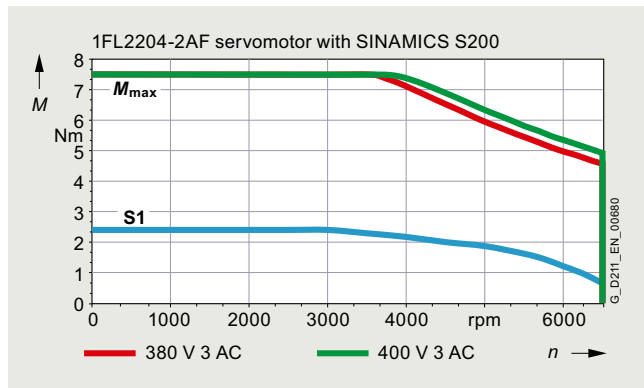
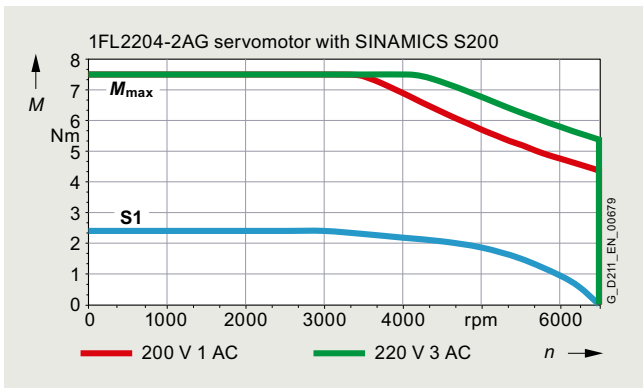

Technical specifications

SIMOTICS S-1FL2 shaft height 45

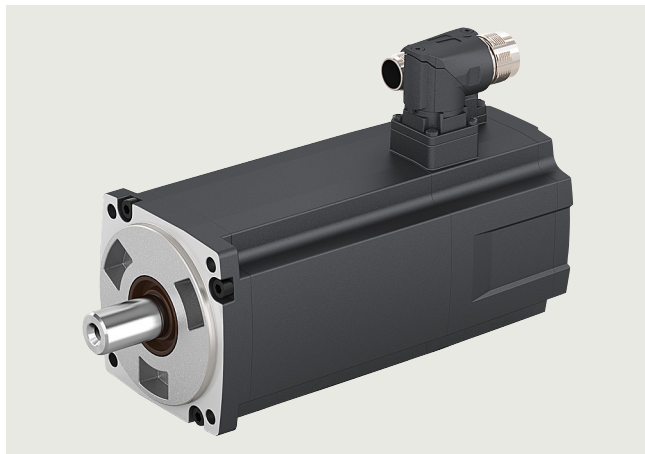

Specific technical specifications

SIMOTICS S-1FL2 servomotors		High Inertia	
Shaft height 45		1FL2304-2AF	1FL2304-4AF
Static torque M_0	Nm (lb _f -ft)	1.45 (1.07)	3.02 (2.23)
Stall current I_0	A	1.3	2.5
Maximum torque M_{max}	Nm (lb _f -ft)	4.445 (3.28)	8.365 (6.17)
Maximum current I_{max}	A	4.2	7.3
Maximum speed n_{max}	rpm	4000	4000
Rotor moment of inertia J_{Mot}	kg cm ² (lb _f -in ²)	2.69 (0.92)	5.18 (1.77)
Moment of inertia (with brake) $J_{Mot Br}$	kg cm ² (lb _f -in ²)	3.05 (1.04)	5.54 (1.89)
Weight m_{Mot}	kg (lb)	3.5 (7.72)	5.4 (11.9)
Weight (with brake) $m_{Mot Br}$	kg (lb)	4.9 (10.8)	6.8 (15.0)
200 ... 240 V 1 AC / 3 AC			
Rated speed n_N	rpm	–	–
Rated torque M_N	Nm (lb _f -ft)	–	–
Rated current I_N	A	–	–
Rated power P_N	W	–	–
380 ... 480 V 3 AC			
Rated speed n_N	rpm	3000	3000
Rated torque M_N	Nm (lb _f -ft)	1.27 (0.94)	2.39 (1.76)
Rated current I_N	A	1.2	2.1
Rated power P_N	W	400	750
Suitable for SINAMICS S200 Basic servo converters			
• 200 ... 240 V 1 AC		–	–
• 200 ... 240 V 3 AC		–	–
Suitable for SINAMICS S200 servo converters			
• 200 ... 240 V 1 AC		–	–
• 200 ... 240 V 3 AC		–	–
• 380 ... 480 V 3 AC		6SL5510-1BE10-4AF0	6SL5510-1BE10-8AF0

SIMOTICS S-1FL2 servomotors for SINAMICS S200

SIMOTICS S-1FL2 shaft height 45

Technical specifications

Dimensional drawing

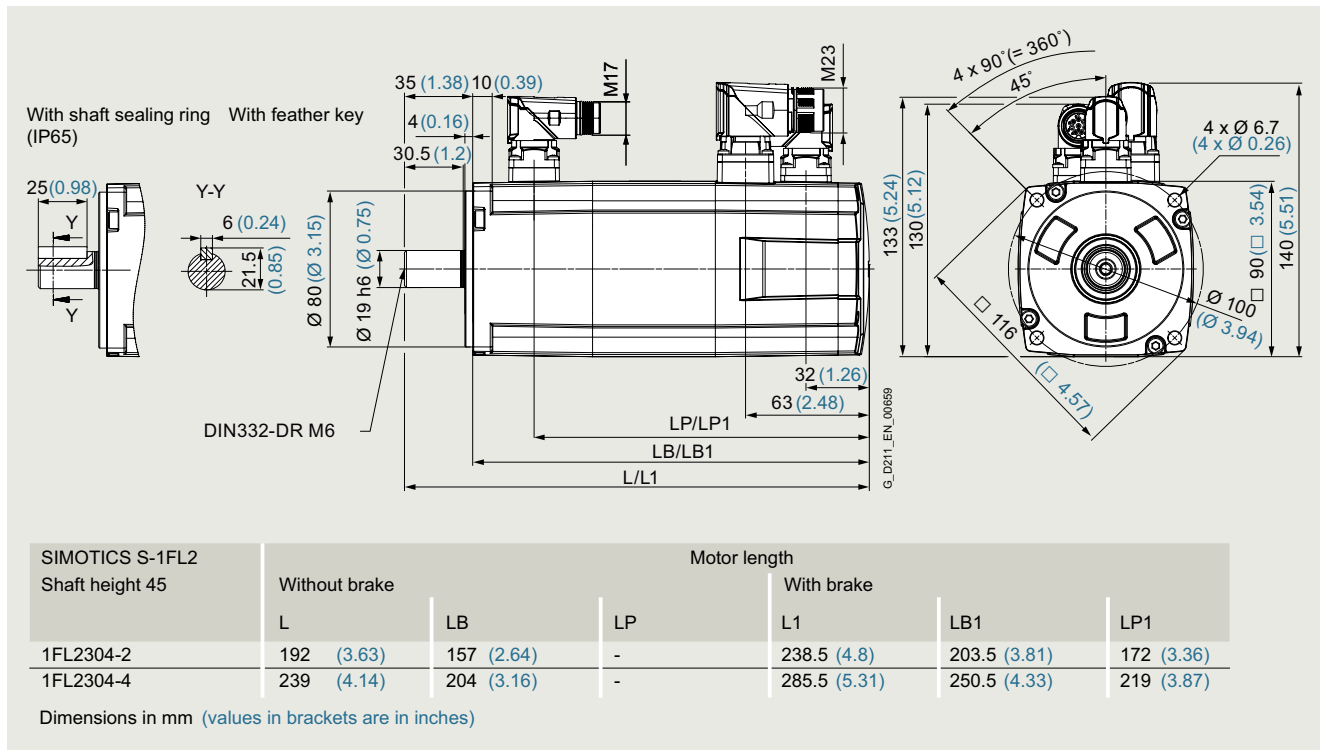

Speed/torque characteristics

High Inertia

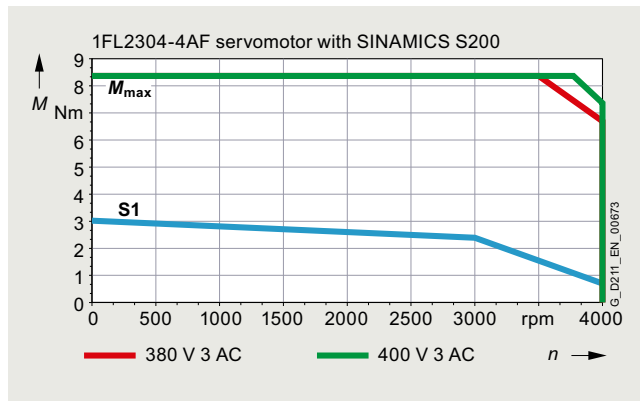
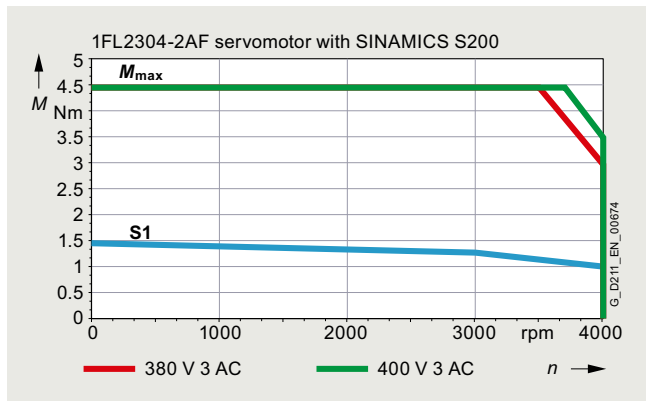

Technical specifications

SIMOTICS S-1FL2 shaft height 48

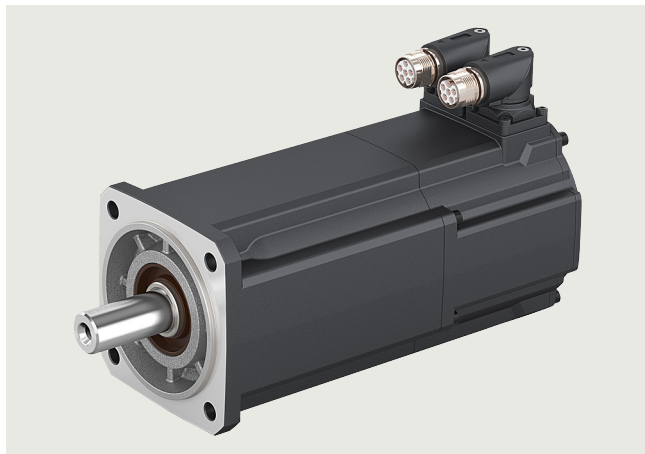

Specific technical specifications

SIMOTICS S-1FL2 servomotors		Medium Inertia	
Shaft height 48		1FL2205-2AF	1FL2205-4AF
Static torque M_0	Nm (lb _f -ft)	3.6 (2.66)	6 (4.43)
Stall current I_0	A	2.9	4.7
Maximum torque M_{max}	Nm (lb _f -ft)	11.5 (8.48)	19.3 (14.2)
Maximum current I_{max}	A	9.5	15.1
Maximum speed n_{max}	rpm	6000	6000
Rotor moment of inertia J_{Mot}	kg cm ² (lb _f -in ²)	3.15 (1.08)	5.1 (1.74)
Moment of inertia (with brake) $J_{Mot Br}$	kg cm ² (lb _f -in ²)	4.03 (1.38)	5.98 (2.04)
Weight m_{Mot}	kg (lb)	3.6 (7.94)	5 (11.0)
Weight (with brake) $m_{Mot Br}$	kg (lb)	4.7 (10.4)	6.1 (13.5)
200 ... 240 V 1 AC / 3 AC			
Rated speed n_N	rpm	–	–
Rated torque M_N	Nm (lb _f -ft)	–	–
Rated current I_N	A	–	–
Rated power P_N	W	–	–
380 ... 480 V 3 AC			
Rated speed n_N	rpm	3000	3000
Rated torque M_N	Nm (lb _f -ft)	3 (2.21)	4.6 (3.39)
Rated current I_N	A	2.5	3.75
Rated power P_N	W	940	1450
Suitable for SINAMICS S200 Basic servo converters			
• 200 ... 240 V 1 AC		–	–
• 200 ... 240 V 3 AC		–	–
Suitable for SINAMICS S200 servo converters			
• 200 ... 240 V 1 AC		–	–
• 200 ... 240 V 3 AC		–	–
• 380 ... 480 V 3 AC		6SL5510-1BE11-0AF0	6SL5510-1BE11-5AF0

SIMOTICS S-1FL2 servomotors for SINAMICS S200

SIMOTICS S-1FL2 shaft height 48

Technical specifications

Dimensional drawing

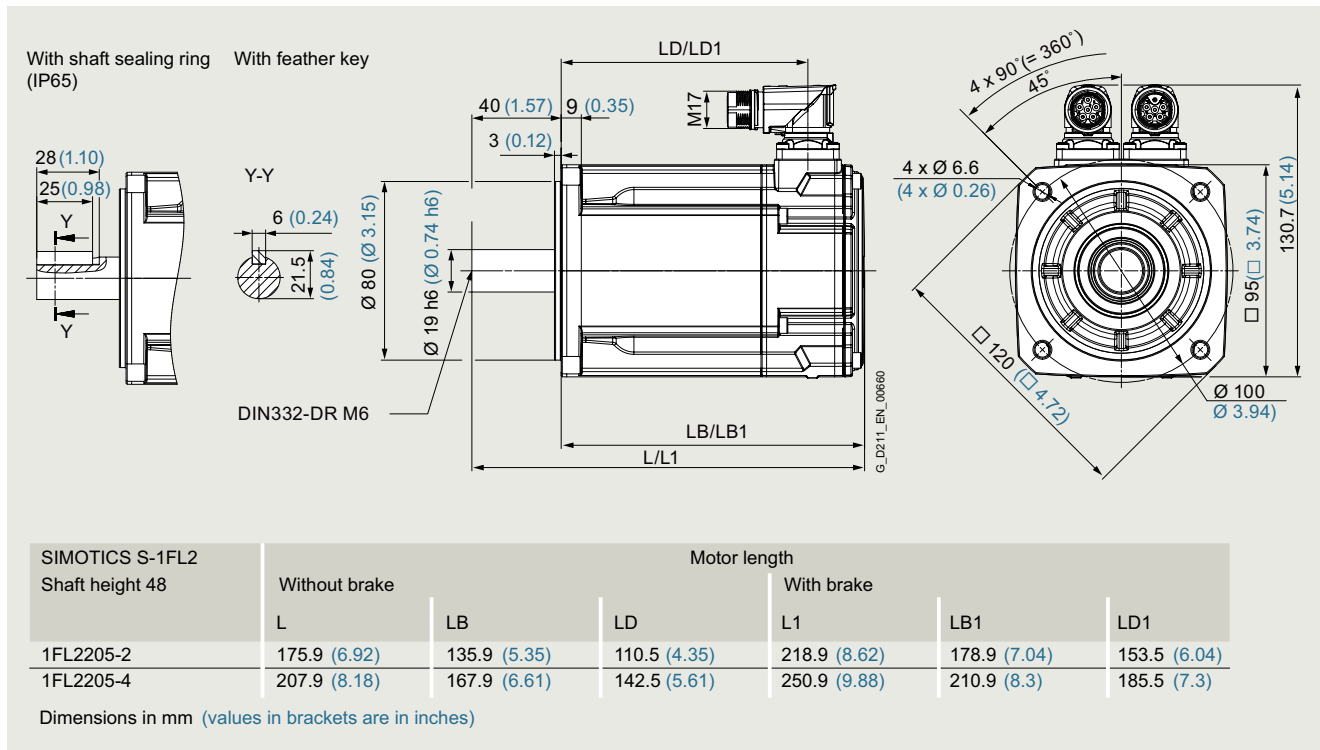

Speed/torque characteristics

Medium Inertia

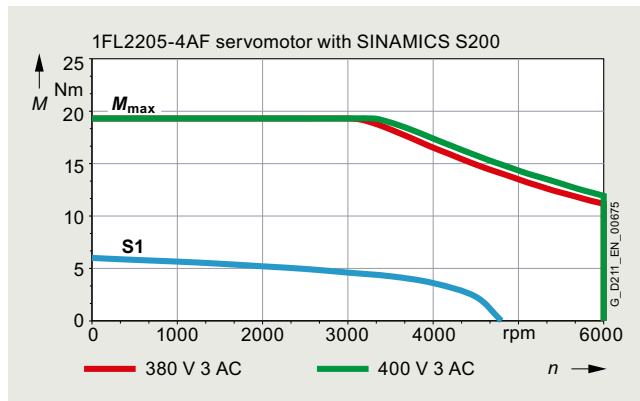
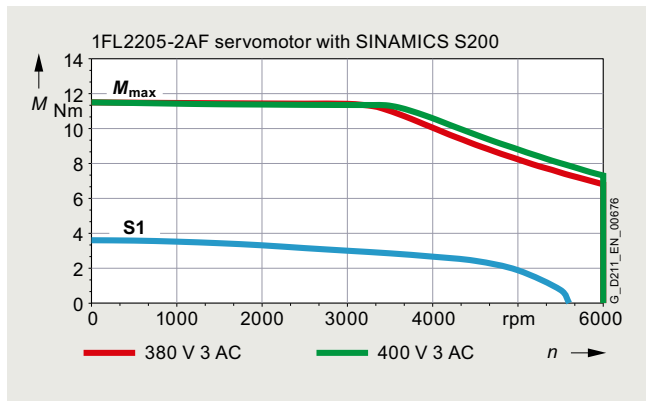

Technical specifications

SIMOTICS S-1FL2 shaft height 52

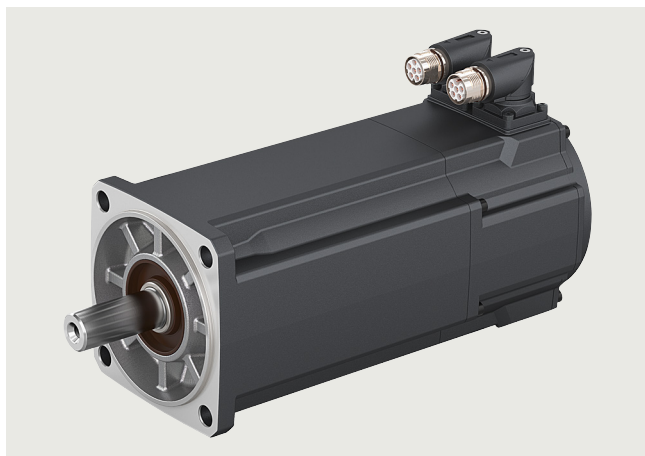

Specific technical specifications

SIMOTICS S-1FL2 servomotors		Low Inertia	
Shaft height 52		1FL2105-2AF	1FL2105-4AF
Static torque M_0	Nm (lb _f -ft)	5 (3.69)	8 (5.90)
Stall current I_0	A	4.65	6.7
Maximum torque M_{max}	Nm (lb _f -ft)	15.9 (11.7)	25.3 (18.7)
Maximum current I_{max}	A	18	24
Maximum speed n_{max}	rpm	6000	6000
Rotor moment of inertia J_{Mot}	kg cm ² (lb _f -in ²)	1.71 (0.58)	2.65 (0.91)
Moment of inertia (with brake) $J_{Mot Br}$	kg cm ² (lb _f -in ²)	2.54 (0.87)	3.48 (1.19)
Weight m_{Mot}	kg (lb)	5.5 (12.1)	7.8 (17.2)
Weight (with brake) $m_{Mot Br}$	kg (lb)	6.4 (14.1)	8.7 (19.2)
200 ... 240 V 3 AC			
Rated speed n_N	rpm	–	–
Rated torque M_N	Nm (lb _f -ft)	–	–
Rated current I_N	A	–	–
Rated power P_N	W	–	–
380 ... 480 V 3 AC			
Rated speed n_N	rpm	3000	3000
Rated torque M_N	Nm (lb _f -ft)	4.6 (3.39)	6.6 (4.87)
Rated current I_N	A	4.35	5.6
Rated power P_N	W	1450	2100
Suitable for SINAMICS S200 Basic servo converters			
• 200 ... 240 V 1 AC		–	–
• 200 ... 240 V 3 AC		–	–
Suitable for SINAMICS S200 servo converters			
• 200 ... 240 V 1 AC		–	–
• 200 ... 240 V 3 AC		–	–
• 380 ... 480 V 3 AC		6SL5510-1BE11-5AF0	6SL5510-1BE12-5AF0

SIMOTICS S-1FL2 servomotors for SINAMICS S200

SIMOTICS S-1FL2 shaft height 52

Technical specifications

Dimensional drawing

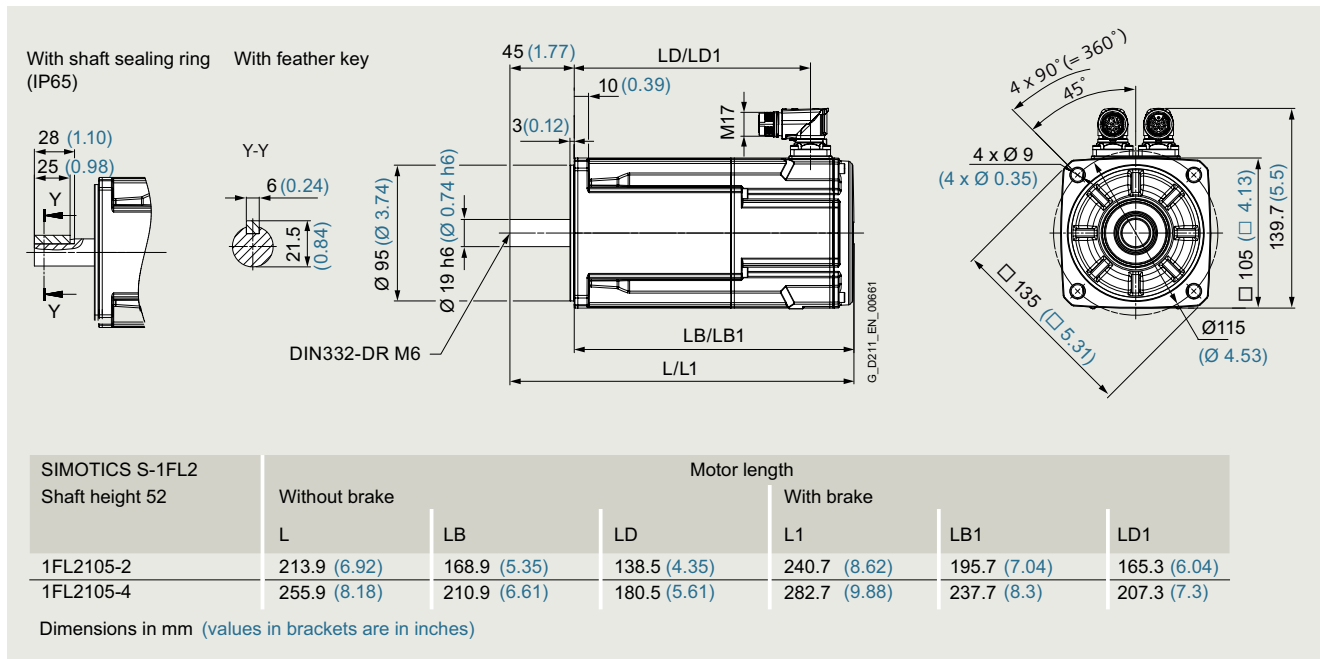

Speed/torque characteristics

Low Inertia

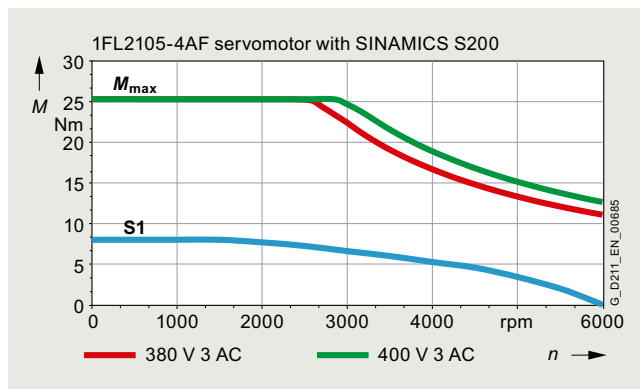
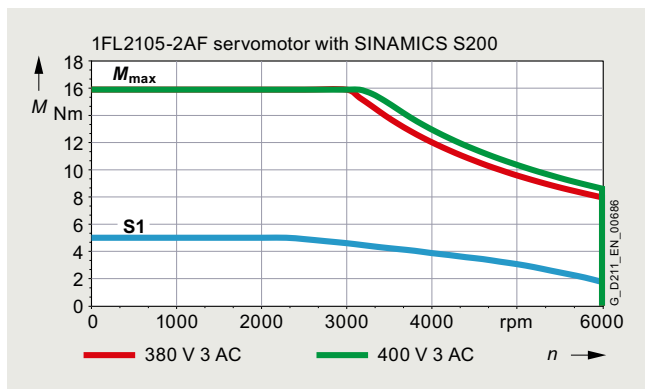

Technical specifications

SIMOTICS S-1FL2 shaft height 65

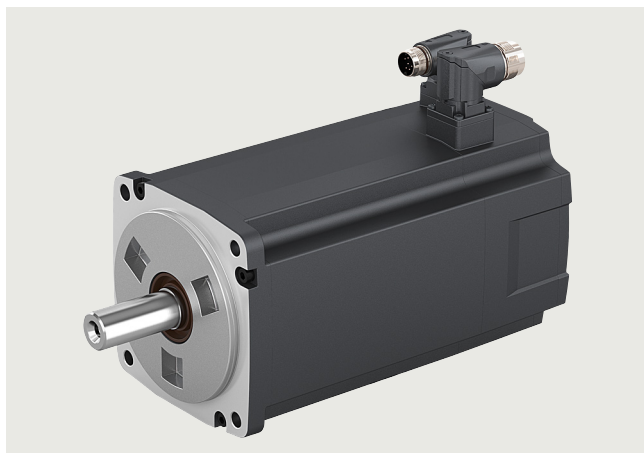

Specific technical specifications

SIMOTICS S-1FL2 servomotors		High Inertia				
Shaft height 65		1FL2306-1AC	1FL2306-2AC	1FL2306-4AC	1FL2306-6AC	1FL2306-7AC
Static torque M_0	Nm (lb _f -ft)	3.7 (2.73)	5 (3.69)	8 (5.90)	8.8 (6.49)	13.3 (9.81)
Stall current I_0	A	2.5	3	4.9	5.3	7.8
Maximum torque M_{max}	Nm (lb _f -ft)	12 (8.85)	17 (12.5)	22 (16.2)	30 (22.1)	33.425 (24.7)
Maximum current I_{max}	A	8.4	10.7	14.1	19	20.7
Maximum speed n_{max}	rpm	3000	3000	3000	3000	3000
Rotor moment of inertia J_{Mot}	kg cm ² (lb _f -in ²)	7.96 (2.72)	11.65 (3.98)	15.29 (5.22)	22.61 (7.73)	29.94 (10.2)
Moment of inertia (with brake) $J_{Mot Br}$	kg cm ² (lb _f -in ²)	9.57 (3.27)	13.26 (4.53)	16.9 (5.77)	24.22 (8.28)	31.55 (10.8)
Weight m_{Mot}	kg (lb)	5.9 (13.0)	7.3 (16.1)	8.6 (19.0)	11.1 (24.5)	13.7 (30.2)
Weight (with brake) $m_{Mot Br}$	kg (lb)	8.9 (19.6)	10.3 (22.7)	11.6 (25.6)	14.1 (31.1)	16.7 (36.8)
200 ... 240 V 3 AC						
Rated speed n_N	rpm	–	–	–	–	–
Rated torque M_N	Nm (lb _f -ft)	–	–	–	–	–
Rated current I_N	A	–	–	–	–	–
Rated power P_N	W	–	–	–	–	–
380 ... 480 V 3 AC						
Rated speed n_N	rpm	2000	2000	2000	2000	2000
Rated torque M_N	Nm (lb _f -ft)	3.58 (2.64)	4.78 (3.53)	7.16 (5.28)	8.4 (6.20)	9.6 (7.08)
Rated current I_N	A	2.5	3	4.6	5.3	5.9
Rated power P_N	W	750	1000	1500	1750	2000
Suitable for SINAMICS S200 Basic servo converters						
• 200 ... 240 V 1 AC		–	–	–	–	–
• 200 ... 240 V 3 AC		–	–	–	–	–
Suitable for SINAMICS S200 servo converters						
• 200 ... 240 V 1 AC		–	–	–	–	–
• 200 ... 240 V 3 AC		–	–	–	–	–
• 380 ... 480 V 3 AC		6SL5510-1BE10-8AF0	6SL5510-1BE11-0AF0	6SL5510-1BE11-5AF0	6SL5510-1BE11-5AF0	6SL5510-1BE12-5AF0

SIMOTICS S-1FL2 servomotors for SINAMICS S200

SIMOTICS S-1FL2 shaft height 65

Technical specifications

Dimensional drawing

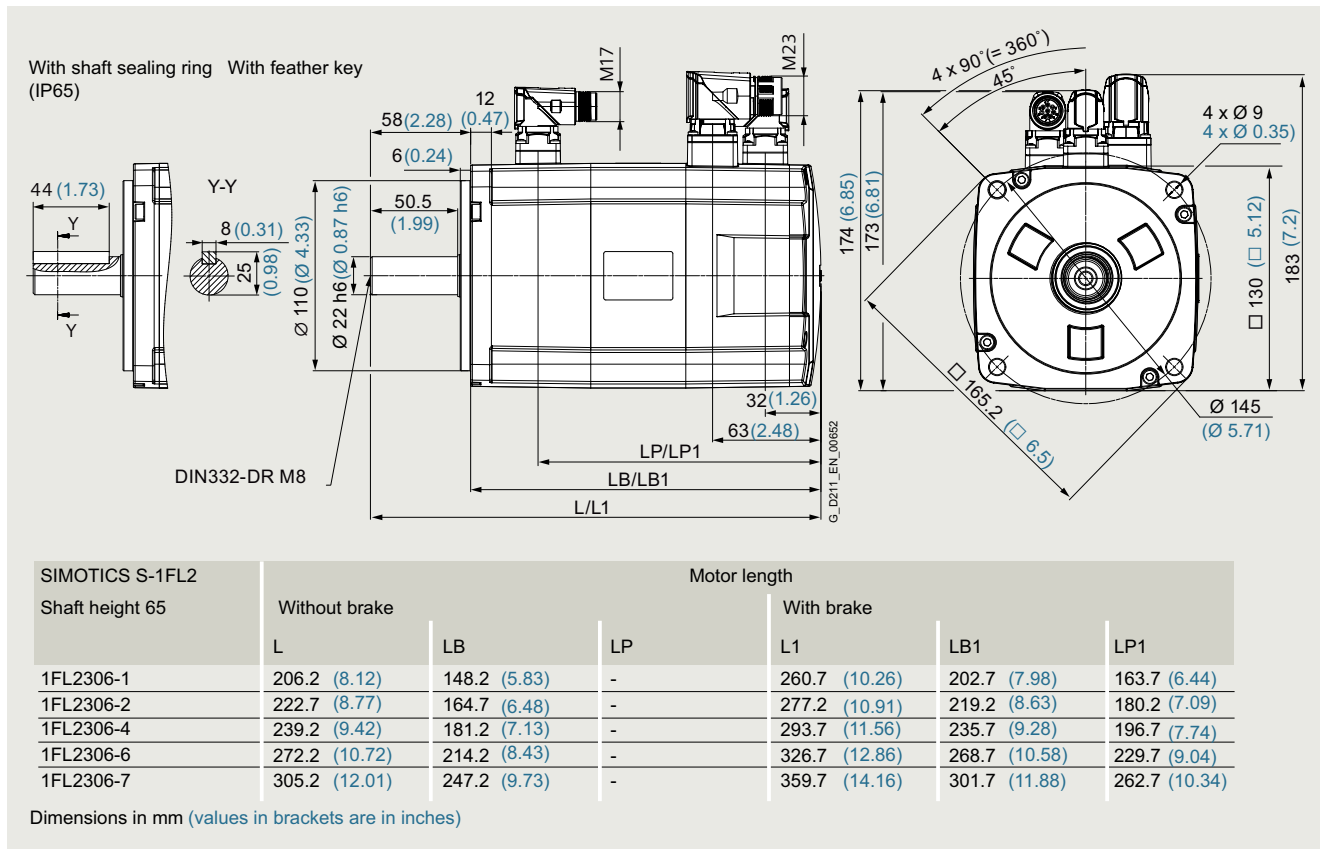

Speed/torque characteristics

High Inertia

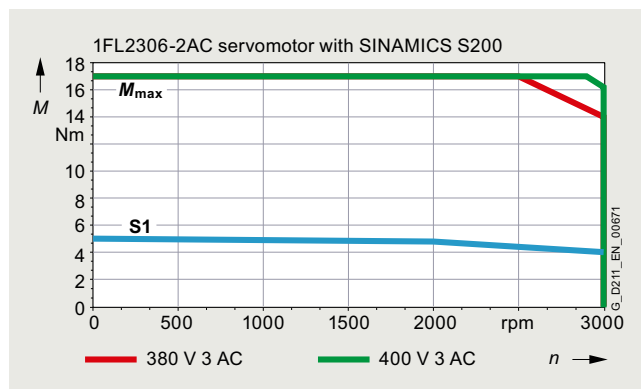
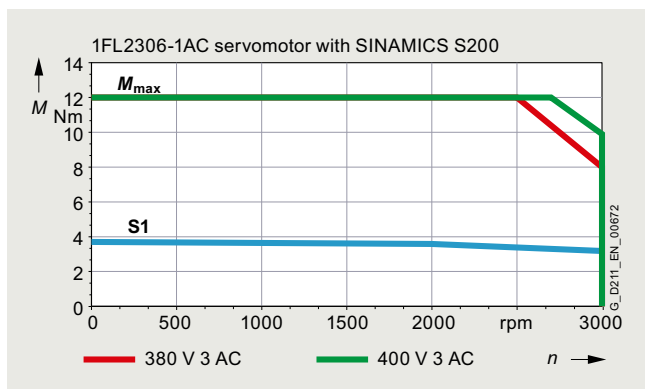

Technical specifications

High Inertia (continued)

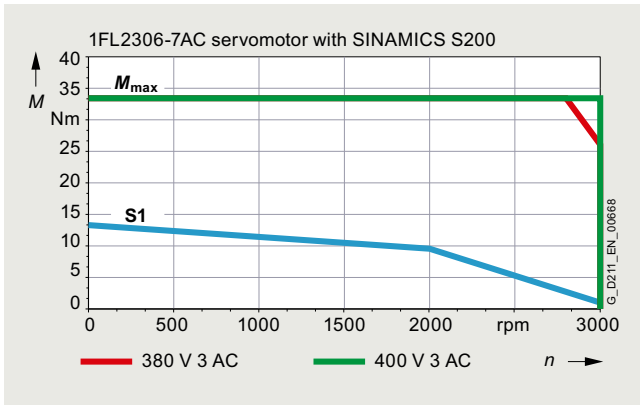
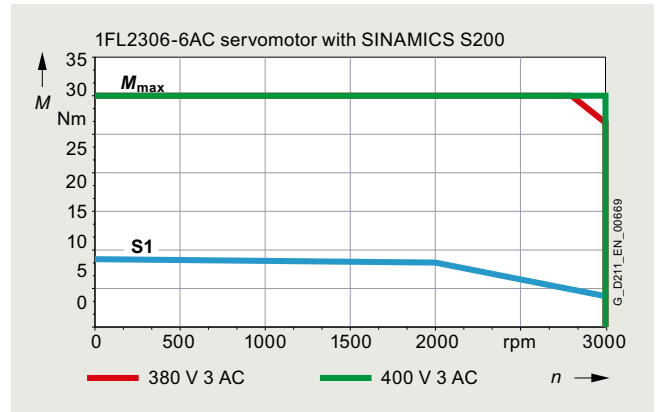
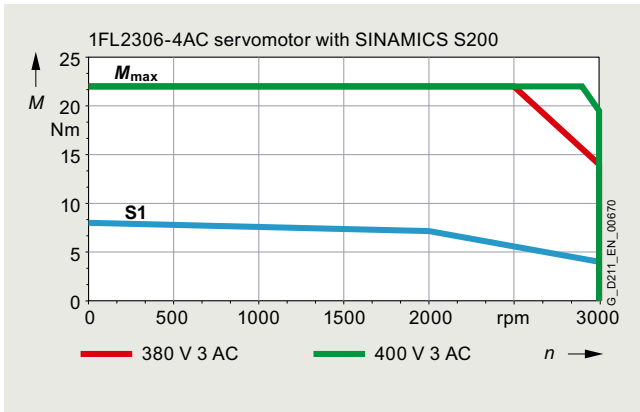

SIMOTICS S-1FL2 servomotors for SINAMICS S200

SIMOTICS S-1FL2 shaft height 90

Technical specifications

SIMOTICS S-1FL2 shaft height 90

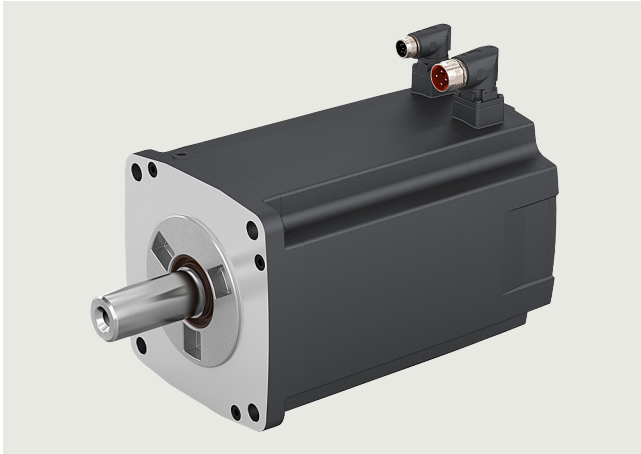

Specific technical specifications

SIMOTICS S-1FL2 servomotors		High Inertia			
Shaft height 90		1FL2310-0AC	1FL2310-2AC	1FL2310-4AC	1FL2310-6AC
Static torque M_0	Nm (lb _f -ft)	12.6 (9.29)	18.1 (13.4)	25.2 (18.6)	35.2 (26.0)
Stall current I_0	A	7.8	11	12.6	13.2
Maximum torque M_{max}	Nm (lb _f -ft)	37.5 (27.7)	55 (40.6)	70 (51.6)	90 (66.4)
Maximum current I_{max}	A	25.2	36.2	36.9	35.6
Maximum speed n_{max}	rpm	3000	3000	2500	2000
Rotor moment of inertia J_{Mot}	kg cm ² (lb _f -in ²)	47.41 (16.2)	69.1 (23.6)	90.83 (30.9)	134.29 (45.9)
Moment of inertia (with brake) $J_{Mot Br}$	kg cm ² (lb _f -in ²)	56.78 (19.4)	78.47 (26.8)	100.2 (34.2)	143.66 (49.1)
Weight m_{Mot}	kg (lb)	15.4 (34.0)	19.4 (42.8)	23.7 (52.3)	31.9 (70.3)
Weight (with brake) $m_{Mot Br}$	kg (lb)	21.4 (47.2)	25.4 (56.0)	29.7 (65.5)	37.9 (83.6)
200 ... 240 V 3 AC					
Rated speed n_N	rpm	–	–	–	–
Rated torque M_N	Nm (lb _f -ft)	–	–	–	–
Rated current I_N	A	–	–	–	–
Rated power P_N	W	–	–	–	–
380 ... 480 V 3 AC					
Rated speed n_N	rpm	2000	2000	2000	2000
Rated torque M_N	Nm (lb _f -ft)	11.9 (8.78)	16.7 (12.3)	23.9 (17.6)	33.4 (24.6)
Rated current I_N	A	7.8	11	12.6	13.2
Rated power P_N	W	2500	3500	5000	7000
Suitable for SINAMICS S200 Basic servo converters					
• 200 ... 240 V 1 AC		–	–	–	–
• 200 ... 240 V 3 AC		–	–	–	–
Suitable for SINAMICS S200 servo converters					
• 200 ... 240 V 1 AC		–	–	–	–
• 200 ... 240 V 3 AC		–	–	–	–
• 380 ... 480 V 3 AC		6SL5510-1BE12-5AF0	6SL5510-1BE13-5AF0	6SL5510-1BE15-0AF0	6SL5510-1BE17-0AF0

SIMOTICS S-1FL2 servomotors for SINAMICS S200

SIMOTICS S-1FL2 shaft height 90

Technical specifications

Dimensional drawing

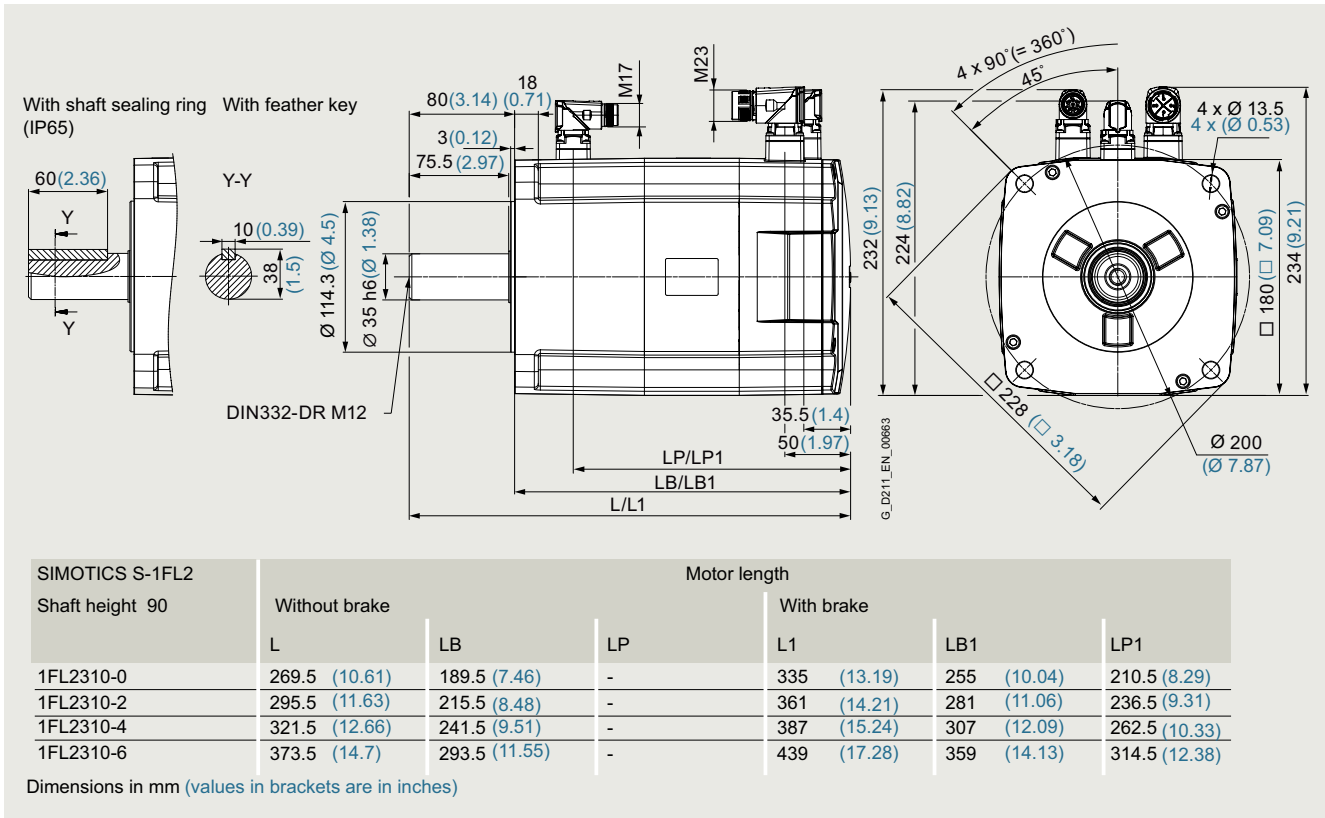

Speed/torque characteristics

High Inertia

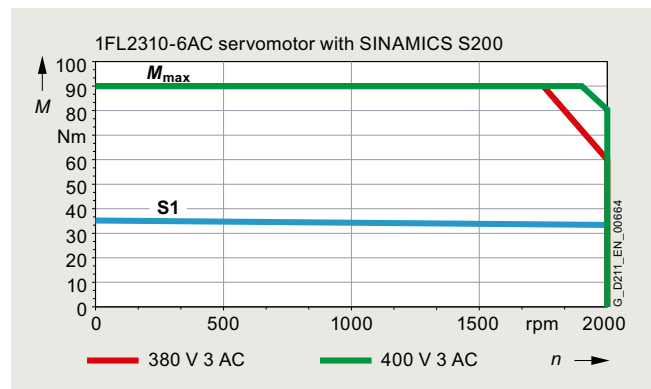
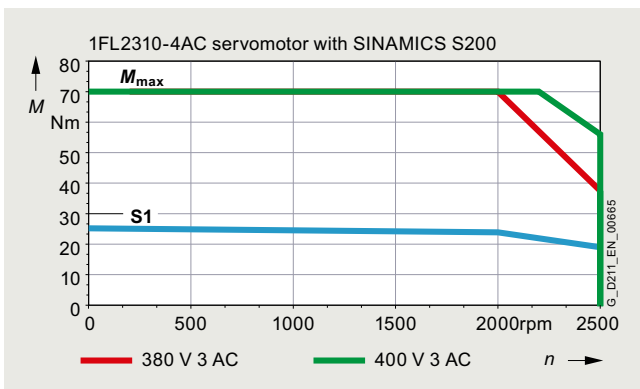
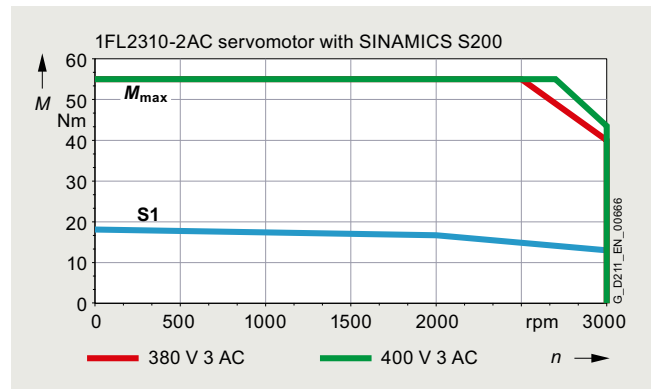
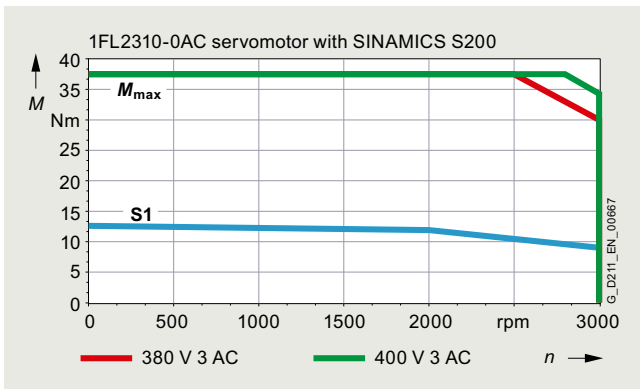

SIMOTICS S-1FL2 servomotors for SINAMICS S200

Notes

3

MOTION-CONNECT connection systems

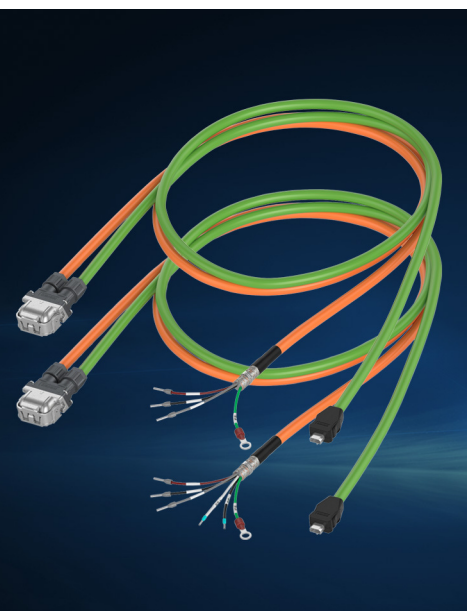

4/2 MOTION-CONNECT 350 and 380
4/2 Overview

4/3 Pre-assembled dual cables for power and communication for SINAMICS S200

4/3 Overview

4/3 Technical specifications

4/4 Pre-assembled power cables for SINAMICS S200

4/4 Overview

4/4 Technical specifications

4/5 Pre-assembled signal cables for SINAMICS S200

4/5 Overview

4/5 Technical specifications

4/6 Pre-assembled brake cables for SINAMICS S200

4/6 Overview

4/6 Technical specifications

4/7 Connectors for SINAMICS S200

4/7 Overview

For **selection and ordering data** please refer to section "System overview" "SINAMICS S200 servo drive system" from page 1/14.

Detailed technical information on SINAMICS S200 is available on the internet at:
www.siemens.com/sinamics-s200/documentation

In addition, the Siemens Product Configurator can be used on the internet at the following address:
www.siemens.com/sinamics-s200/configuration

MOTION-CONNECT connection systems

MOTION-CONNECT 350 and 380

Overview

The use of pre-assembled MOTION-CONNECT 350/380 cables ensures high quality and system-tested, problem-free operation.

Degree of protection of pre-assembled power and signal cables is IP65 when closed and connected unless otherwise stated.

MOTION-CONNECT 350/380 cables are not suitable for outdoor use.

MOTION-CONNECT 350/380 cables are approved for a maximum horizontal travel distance of 5 m without support.

The cables must be unwound without twisting.

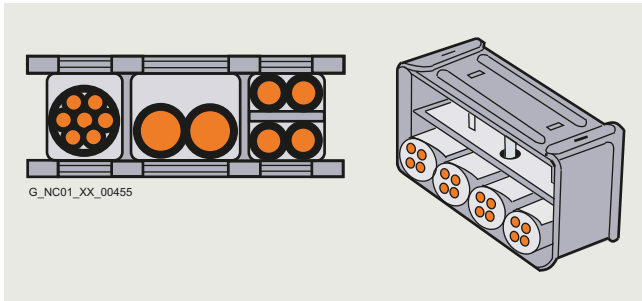

To maximize the service life of the cable carrier and cables, cables in the carrier made from different materials must be separated in the cable carrier using spacers. The spacers must be filled evenly to ensure that the position of the cables does not change during operation. The cables should be distributed as symmetrically as possible according to their weights and dimensions. Cables with different outer diameters should be separated by spacers as well.

When inserting pre-assembled cables into the cable carrier, do not pull at the connector, as this may damage the strain relief or cable clamping.

The cables must not be fixed in the cable carrier. They must be freely movable.

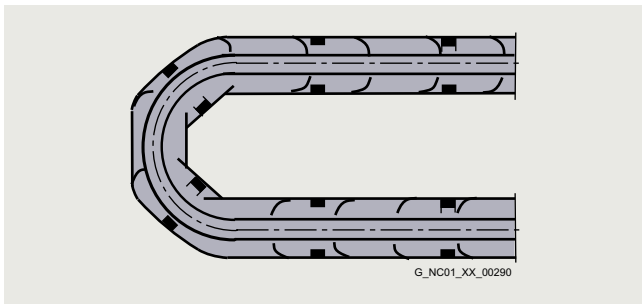

The cables must be able to be moved without applying force, specifically in the bending radii of the carrier. The specified minimum bending radii must be adhered to.

The cable fixings must be attached at both ends at an appropriate distance from the end points of the moving parts in a dead zone.

Cables must be installed in accordance with the instructions supplied by the cable carrier manufacturer.

In case of vibration load and with horizontal or vertical cable entries, we recommend that the cable is additionally fixed if between the cable strain relief on the cable carrier and the terminal at the motor part of the cable is hanging loose or is not routed. To prevent machine vibrations being transmitted to the connectors, the cable should be fixed at the moving part where the motor is mounted.

Derating factors for power and signal cables

Ambient air temperature °C (°F)	Derating factor according to EN 60204-1 Table D.1
30 (86)	1.10
35 (95)	1.05
40 (104)	1.00
45 (113)	0.96
50 (122)	0.90
55 (131)	0.84
60 (140)	0.78

Overview

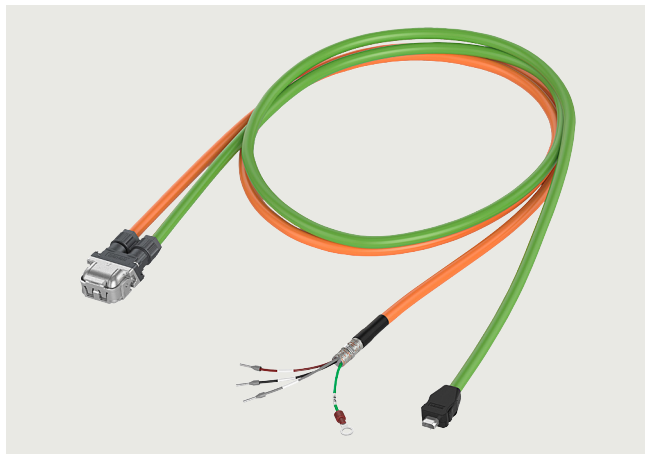

Example: MOTION-CONNECT 350/380, dual cable without brake cores for SIMOTICS S-1FL2 Low Inertia/Medium Inertia servomotors

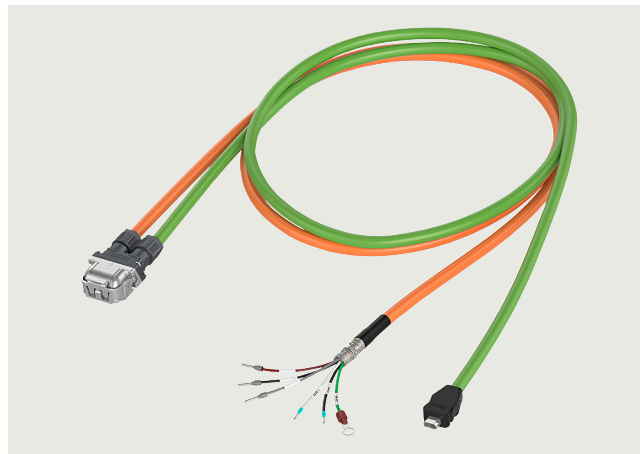

Example: MOTION-CONNECT 350/380, dual cable with brake cores for SIMOTICS S-1FL2 Low Inertia/Medium Inertia servomotors

For selection and ordering data please refer to section "System overview" "SINAMICS S200 servo drive system" from page 1/14.

Technical specifications

Product name	MOTION-CONNECT 350 dual cable without brake cores	MOTION-CONNECT 380 dual cable without brake cores	MOTION-CONNECT 350 dual cable with brake cores	MOTION-CONNECT 380 dual cable with brake cores
	SINAMICS S200 200 ... 240 V 1 AC / 3 AC and SINAMICS S200 380 ... 480 V 3 AC	SINAMICS S200 200 ... 240 V 1 AC / 3 AC and SINAMICS S200 380 ... 480 V 3 AC	SINAMICS S200 200 ... 240 V 1 AC / 3 AC and SINAMICS S200 380 ... 480 V 3 AC	SINAMICS S200 200 ... 240 V 1 AC / 3 AC and SINAMICS S200 380 ... 480 V 3 AC
	–	–	–	–
	SIMOTICS S-1FL2 Low Inertia, 0 .05 kW ... 1 kW	SIMOTICS S-1FL2 Low Inertia, 0.05 kW ... 1 kW	SIMOTICS S-1FL2 Low Inertia, 0.05 kW ... 1 kW	SIMOTICS S-1FL2 Low Inertia, 0.05 kW ... 1 kW
	SIMOTICS S-1FL2 Medium Inertia, 0.2 kW ... 1 kW	SIMOTICS S-1FL2 Medium Inertia, 0.2 kW ... 1 kW	SIMOTICS S-1FL2 Medium Inertia, 0.2 kW ... 1 kW	SIMOTICS S-1FL2 Medium Inertia, 0.2 kW ... 1 kW
Type	6FX3502-7CD01-.... 6FX3502-7CN01-....	6FX3802-7CD01-.... 6FX3802-7CN01-....	6FX3502-7DD01-.... 6FX3502-7DN01-....	6FX3802-7DD01-.... 6FX3802-7DN01-....
No. of cores	10	10	12	12
Degree of protection motor side (when closed and connected)	IP65	IP65	IP65	IP65
Certificate of suitability				
• RoHS	Yes	Yes	Yes	Yes
• CE and UKCA	Yes	Yes	Yes	Yes
Rated voltage U_0/U	300 V/1000 V	300 V/1000 V	300 V/1000 V	300 V/1000 V
Test voltage, rms	4 kV	4 kV	4 kV	4 kV
Operating temperature on the surface				
• Fixed installation	-20 ... +80 °C	-20 ... +80 °C	-20 ... +80 °C	-20 ... +80 °C
Tensile stress, max.				
• Fixed installation	50 N/mm ²	50 N/mm ²	50 N/mm ²	50 N/mm ²
• Flexible installation	20 N/mm ²	20 N/mm ²	20 N/mm ²	20 N/mm ²
Smallest bending radius				
• Fixed installation	4 × diameter	4 × diameter	4 × diameter	4 × diameter
• Flexible installation	7.5 × diameter	7.5 × diameter	7.5 × diameter	7.5 × diameter
Torsional stress	Absolute 30°/m	Absolute 30°/m	Absolute 30°/m	Absolute 30°/m
Bending	1000000	5000000	1000000	5000000
Insulation material, incl. jacket	PP	PP	PP	PP
Oil resistance	EN 60811-2-1	EN 60811-2-1	EN 60811-2-1	EN 60811-2-1
Outer jacket	PVC	PUR	PVC	PUR
Flame-retardant	EN 60332-1-1 to 1-3	EN 60332-1-1 to 1-3	EN 60332-1-1 to 1-3	EN 60332-1-1 to 1-3

MOTION-CONNECT connection systems

Pre-assembled power cables for SINAMICS S200

Overview



Example: MOTION-CONNECT 350/380, power cable without brake cores for SIMOTICS S-1FL2 High Inertia servomotors

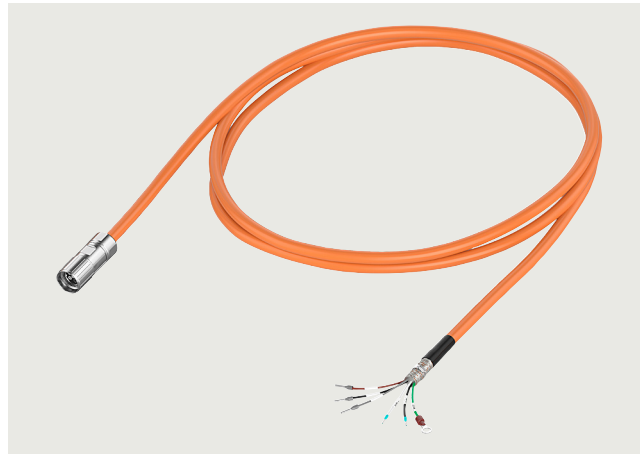

Example: MOTION-CONNECT 350/380, power cable with brake cores for SIMOTICS S-1FL2 Low Inertia/Medium Inertia servomotors

For selection and ordering data please refer to section "System overview" "SINAMICS S200 servo drive system" from page 1/14.

Technical specifications

Product name	MOTION-CONNECT 350 power cable			MOTION-CONNECT 380 power cable		
	without brake cores		with brake cores	without brake cores		with brake cores
	SINAMICS S200 380 ... 480 V 3 AC	SINAMICS S200 380 ... 480 V 3 AC	SINAMICS S200 380 ... 480 V 3 AC	SINAMICS S200 380 ... 480 V 3 AC	SINAMICS S200 380 ... 480 V 3 AC	SINAMICS S200 380 ... 480 V 3 AC
	SIMOTICS S-1FL2 Low Inertia, 1.5 kW ... 2 kW	SIMOTICS S-1FL2 High Inertia, 0.4 kW ... 7 kW	SIMOTICS S-1FL2 Low Inertia, 1.5 kW ... 2 kW	SIMOTICS S-1FL2 Low Inertia, 1.5 kW ... 2 kW	SIMOTICS S-1FL2 High Inertia, 0.4 kW ... 7 kW	SIMOTICS S-1FL2 Low Inertia, 1.5 kW ... 2 kW
	SIMOTICS S-1FL2 Medium Inertia, 1 kW ... 1.5 kW		SIMOTICS S-1FL2 Medium Inertia, 1 kW ... 1.5 kW	SIMOTICS S-1FL2 Medium Inertia, 1 kW ... 1.5 kW		SIMOTICS S-1FL2 Medium Inertia, 1 kW ... 1.5 kW
Type	6FX3502-5CK32-....	6FX3502-5CL01-.... 6FX3502-5CL02-.... 6FX3502-5CL12-....	6FX3502-5DK32-....	6FX3802-5CK32-....	6FX3802-5CL01-.... 6FX3802-5CL02-.... 6FX3802-5CL12-....	6FX3802-5DK32-....
No. of cores	4	4	6	4	4	6
Degree of protection motor side (when closed and connected)	IP65	IP65	IP65	IP65	IP65	IP65
Certificate of suitability						
• RoHS	Yes	Yes	Yes	Yes	Yes	Yes
• CE and UKCA	Yes	Yes	Yes	Yes	Yes	Yes
Rated voltage U_0/U	600 V/1000 V	600 V/1000 V	600 V/1000 V	600 V/1000 V	600 V/1000 V	600 V/1000 V
Test voltage, rms	4 kV	4 kV	4 kV	4 kV	4 kV	4 kV
Operating temperature on the surface						
• Fixed installation	-20 ... +80 °C	-20 ... +80 °C	-20 ... +80 °C	-20 ... +80 °C	-20 ... +80 °C	-20 ... +80 °C
Tensile stress, max.						
• Fixed installation	50 N/mm ²	50 N/mm ²	50 N/mm ²	50 N/mm ²	50 N/mm ²	50 N/mm ²
• Flexible installation	20 N/mm ²	20 N/mm ²	20 N/mm ²	20 N/mm ²	20 N/mm ²	20 N/mm ²
Smallest bending radius						
• Fixed installation	4 × diameter	4 × diameter	4 × diameter	4 × diameter	4 × diameter	4 × diameter
• Flexible installation	7.5 × diameter	7.5 × diameter	7.5 × diameter	7.5 × diameter	7.5 × diameter	7.5 × diameter
Torsional stress	Absolute 30°/m	Absolute 30°/m	Absolute 30°/m	Absolute 30°/m	Absolute 30°/m	Absolute 30°/m
Bending	1000000	1000000	1000000	5000000	5000000	5000000
Insulation material, incl. jacket	PP	PP	PP	PP	PP	PP
Oil resistance	EN 60811-2-1	EN 60811-2-1	EN 60811-2-1	EN 60811-2-1	EN 60811-2-1	EN 60811-2-1
Outer jacket	PVC	PVC	PVC	PUR	PUR	PUR
Flame-retardant	EN 60332-1-1 to 1-3	EN 60332-1-1 to 1-3	EN 60332-1-1 to 1-3	EN 60332-1-1 to 1-3	EN 60332-1-1 to 1-3	EN 60332-1-1 to 1-3

Overview

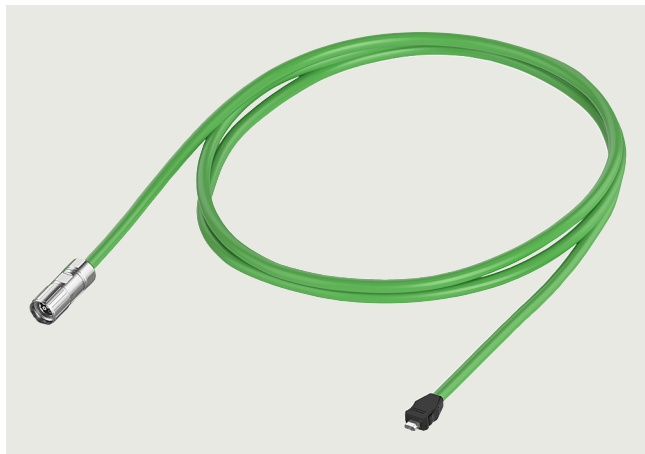

Example: MOTION-CONNECT 350/380, signal cable for encoder connection for SIMOTICS S-1FL2 Medium Inertia servomotors



Example: MOTION-CONNECT 350/380, signal cable for encoder connection for SIMOTICS S-1FL2 High Inertia servomotors

For selection and ordering data please refer to section "System overview" "SINAMICS S200 servo drive system" from page 1/14.

Technical specifications

Product name	MOTION-CONNECT 350 signal cable for encoder connection		MOTION-CONNECT 380 signal cable for encoder connection	
	SINAMICS S200 380 ... 480 V 3 AC	SINAMICS S200 380 ... 480 V 3 AC	SINAMICS S200 380 ... 480 V 3 AC	SINAMICS S200 380 ... 480 V 3 AC
	–	–	–	–
	SIMOTICS S-1FL2 Low Inertia, 1.5 kW ... 2 kW	SIMOTICS S-1FL2 High Inertia, 0.4 kW ... 7 kW	SIMOTICS S-1FL2 Low Inertia, 1.5 kW ... 2 kW	SIMOTICS S-1FL2 High Inertia, 0.4 kW ... 7 kW
	SIMOTICS S-1FL2 Medium Inertia, 1 kW ... 1.5 kW		SIMOTICS S-1FL2 Medium Inertia, 1 kW ... 1.5 kW	
Type	6FX3502-2XB11-....	6FX3502-2XB12-....	6FX3802-2XB11-....	6FX3802-2XB12-....
No. of cores	6	6	6	6
Degree of protection motor side (when closed and connected)	IP65	IP65	IP65	IP65
Certificate of suitability				
• RoHS	Yes	Yes	Yes	Yes
• CE and UKCA	Yes	Yes	Yes	Yes
Rated voltage U_0/U	30 V/300 V	30 V/300 V	30 V/300 V	30 V/300 V
Test voltage, rms	500 V	500 V	500 V	500 V
Operating temperature on the surface				
• Fixed installation	-20 ... +80 °C	-20 ... +80 °C	-20 ... +80 °C	-20 ... +80 °C
Tensile stress, max.				
• Fixed installation	50 N/mm ²	50 N/mm ²	50 N/mm ²	50 N/mm ²
• Flexible installation	20 N/mm ²	20 N/mm ²	20 N/mm ²	20 N/mm ²
Smallest bending radius				
• Fixed installation	4 × diameter	4 × diameter	4 × diameter	4 × diameter
• Flexible installation	7.5 × diameter	7.5 × diameter	7.5 × diameter	7.5 × diameter
Torsional stress	Absolute 30°/m	Absolute 30°/m	Absolute 30°/m	Absolute 30°/m
Bending	1000000	1000000	5000000	5000000
Insulation material, incl. jacket	PP	PP	PP	PP
Oil resistance	EN 60811-2-1	EN 60811-2-1	EN 60811-2-1	EN 60811-2-1
Outer jacket	PVC	PVC	PUR	PUR
Flame-retardant	EN 60332-1-1 to 1-3	EN 60332-1-1 to 1-3	EN 60332-1-1 to 1-3	EN 60332-1-1 to 1-3

MOTION-CONNECT connection systems

Pre-assembled brake cables for SINAMICS S200

Overview



Example: MOTION-CONNECT 350/380, brake cable for brake connection for SIMOTICS S-1FL2 High Inertia servomotors

For selection and ordering data please refer to section "System overview" "SINAMICS S200 servo drive system" from page 1/14.

Technical specifications

Product name	MOTION-CONNECT 350 brake cable for <u>brake connection</u>	MOTION-CONNECT 380 brake cable for <u>brake connection</u>
	SINAMICS S200 380 ... 480 V 3 AC	SINAMICS S200 380 ... 480 V 3 AC
	–	–
	SIMOTICS S-1FL2 High Inertia, 0.4 kW ... 7 kW	SIMOTICS S-1FL2 High Inertia, 0.4 kW ... 7 kW
Type	6FX3502-5BL03-....	6FX3802-5BL03-....
No. of cores	2	2
Degree of protection motor side (when closed and connected)	IP65	IP65
Certificate of suitability		
• RoHS	Yes	Yes
• CE and UKCA	Yes	Yes
Rated voltage U_0/U	30 V/300 V	30 V/300 V
Test voltage, rms	2000 V	2000 V
Operating temperature on the surface		
• Fixed installation	-20 ... +80 °C	-20 ... +80 °C
Tensile stress, max.		
• Fixed installation	50 N/mm ²	50 N/mm ²
• Flexible installation	20 N/mm ²	20 N/mm ²
Smallest bending radius		
• Fixed installation	4 × diameter	4 × diameter
• Flexible installation	7.5× diameter	7.5× diameter
Torsional stress	Absolute 30°/m	Absolute 30°/m
Bending	1000000	5000000
Insulation material, incl. jacket	PP	PP
Oil resistance	EN 60811-2-1	EN 60811-2-1
Outer jacket	PVC	PUR
Flame-retardant	EN 60332-1-1 to 1-3	EN 60332-1-1 to 1-3

Overview

Shaft height	Connectors drive end direction (DE) for hybrid connection		Connectors non drive end direction (NDE) for hybrid connection		Connectors motor side for power connection		
					for absolute encoder	for brake	
MOTION-CONNECT connectors for SIMOTICS S-1FL2 Low Inertia servomotors							
20, 30, 40	6FX2003-3HD00	6FX2003-3HN00	–	–	–	–	
							
52	–	–	6FX2003-0LL63	6FX2003-0DB63	– (in power connector)		
							
MOTION-CONNECT connectors for SIMOTICS S-1FL2 Medium Inertia servomotors							
30, 40	6FX2003-3HD00	6FX2003-3HN00	–	–	–		
							
48	–	–	6FX2003-0LL63	6FX2003-0DB63	– (in power connector)		
							
MOTION-CONNECT connectors for SIMOTICS S-1FL2 High Inertia servomotors							
45, 65, 90	–	–	6FX2003-0LL13	6FX2003-0DB13	6FX2003-0LL53		
							
	Crimp contacts "power and PE" (2000 pieces per reel) for hybrid connection	Crimp contacts "signal" (2000 pieces per reel) for hybrid connection	Connectors converter side				
			for power connection	IX signal connector, C-code, for absolute encoder	for brake		
MOTION-CONNECT connectors for SINAMICS S200 servo converter							
	6FX2003-7HP00	6FX2003-7HS00	–	6FX2003-0DE61	–		
							

For selection and ordering data please refer to section "System overview" "SINAMICS S200 servo drive system" from page 1/14.

MOTION-CONNECT connection systems

Notes

4

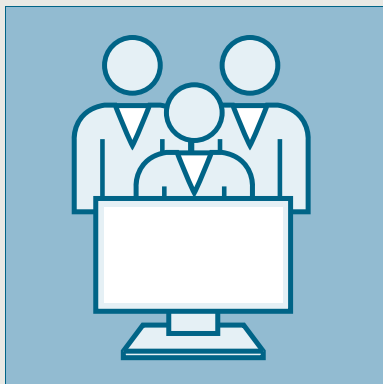

SINAMICS SELECTOR App Mobile selection guide for frequency converters



Siemens has developed the SINAMICS SELECTOR app as a practical tool for finding article numbers for your SINAMICS converter in the power range from 0.1 kW to 630 kW quickly and easily.

Whether for SINAMICS V20, SINAMICS V90, SINAMICS G120C, SINAMICS G120P, SINAMICS G120X, SINAMICS G120, SINAMICS G220 (available soon), SINAMICS S200 (available soon) or SINAMICS S210:

The app will provide you with the correct article numbers conveniently.

How does it work? Simply select your application, the frequency converter you require, the rated power and device options as well as the necessary accessories.

Then you can save your selection and send it by email. The preselection serves as the basis for an order specification with the dealer/Siemens.

You will find free downloads for Android and iOS here:

www.siemens.com/sinamics-selector

5/2	SINAMICS DriveSim Basic
5/4	Siemens Product Configurator
5/5	TIA Selection Tool
5/6	SINAMICS web server for SINAMICS S200
5/10	SINAMICS Startdrive commissioning tool

Security information

Siemens provides products and solutions with industrial security functions that support the secure operation of plants, systems, machines and networks.

In order to protect plants, systems, machines and networks against cyber threats, it is necessary to implement – and continuously maintain – a holistic, state-of-the-art industrial security concept. Siemens' products and solutions constitute one element of such a concept.

Customers are responsible for preventing unauthorized access to their plants, systems, machines and networks. Such systems, machines and components should only be connected to an enterprise network or the internet if and to the extent such a connection is necessary and only when appropriate security measures (e.g. firewalls and/or network segmentation) are in place.

For additional information on industrial security measures that may be implemented, please visit

<https://www.siemens.com/industrialsecurity>

Siemens' products and solutions undergo continuous development to make them more secure. Siemens strongly recommends that product updates are applied as soon as they are available and that the latest product versions are used. Use of product versions that are no longer supported, and failure to apply the latest updates may increase customer's exposure to cyber threats.

To stay informed about product updates, subscribe to the Siemens Industrial Security RSS Feed under

<https://www.siemens.com/cert>

Engineering tools

SINAMICS DriveSim Basic

Overview

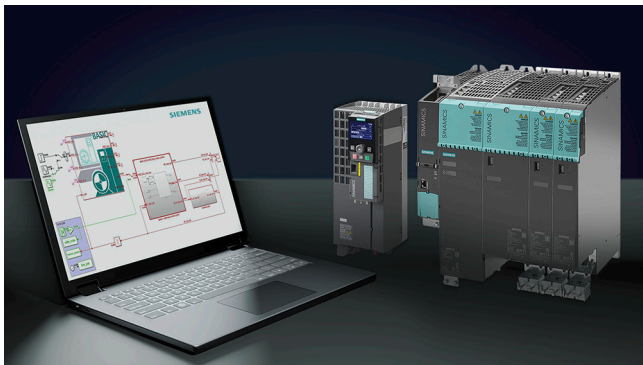

SINAMICS DriveSim Basic provides easy-to-use models for PROFIdrive-enabled SINAMICS converters, so you can create a digital twin of your drive.

The models are validated and tested against real SINAMICS converters and are available in the form of a standardized FMU (Functional Mockup Unit). Therefore, they are compatible with various standard time-based simulation programs such as SIMIT, Simcenter Amesim, ANSYS Twin Builder, MATLAB Simulink or Hopsan.

SINAMICS DriveSim Basic is another element in your engineering toolbox. Together with other virtual Siemens solutions, e.g. SIMATIC S7-PLCSIM Advanced or NX Mechatronics Concept Designer, a consistent model-based development process can be implemented.

Benefit

- Speed up time-to-market for OEMs
- Test validated SINAMICS models under real conditions already at the design or planning stage and make needed adjustments
- Identify issues and improvement capabilities early in the design stage and reduce testing effort to save time and cost
- Download is free of charge. The ideal entry point for drive system simulation
- Valid for the most commonly used Siemens drives

Advantages of SINAMICS DriveSim Basic compared to SIMIT PROFIdrive blocks:

- Increased level of detail due to speed controller, current setpoint filters and internal load model
- Identical parameter values and meaning as in the real SINAMICS device
- Direct reference to SINAMICS documentation
- Validated against the real SINAMICS drive
- No wiring effort to represent functional configurations
- Significant reduction of SIMIT simulation tags (even more is possible if unused in-/ outputs are deselected within the Component Type Editor (CTE))
- Enables simulation of an (internal) two-mass oscillator as application with realistic SINAMICS parameter settings, besides the known limitations by the minimum sample time in SIMIT
- Compatible with every FMU Co-Simulation 2.0 compatible simulation

Application

With SINAMICS DriveSim Basic, you can implement three major use cases:

- Providing load characteristics for drive selection and dimensioning
- Virtual commission your PLC already in the design phase
- Test and improve interaction between PLC, drives and application virtually

Use case 1: Providing load profiles for drive sizing

If you are designing a machine, you want to make sure that you select the SINAMICS converter and SIMOTICS motor most suitable for your drive application. As SINAMICS DriveSim Basic is control-unit-agnostic and thus represents a generic drive, you can parametrize it according to the functionality of your application. Running the simulation results in load characteristics, i.e. torque or speed curves over time. You can import these load profiles into TIA Selection Tool to select the suitable Control Unit and dimension the drive to best fit to the demand. So as a result you have well selected SINAMICS converters and SIMOTICS motors with the help of the digital twin.

Use case 2: Virtual commission your PLC already in the design phase

If you are designing a machine, you want to make sure the PLC code works with your SINAMICS drive. After writing the PLC code in TIA Portal, you can connect it via PLCSIM Advanced to any time-based simulation tool (e.g. SIMIT). Integrated into the simulation tool, SINAMICS DriveSim Basic acts as a realistic communication partner for the PLC. Next, you can commission the virtual PLC in TIA Portal as you would do with a real PLC connected to a real drive. Without simulation, you would need to do that on-site. With simulation, you not only save time, but also have the freedom to try out various configurations and optimize your PLC code early in the process.

Use case 3: Test and improve interaction between PLC, drives and application virtually

With the third Use case, you can connect a simulation tool such as NX Mechatronic Concept Designer to visualize the mechanical movements of your application. This way, you ensure that the drive behaves according to the desired machine performance. You can test several fault scenarios and optimize the interaction between PLC, application and drive virtually so overall, you can avoid unplanned machine behavior and increase the performance of your setup.

Integration

SINAMICS DriveSim Basic can be run in tools that support FMU 2.0 Co-Simulation Import (<https://fmi-standard.org/tools/>).

The FMU has been tested in the following simulation environments and is available in the attached application examples.

Tool	Manufacturer	DriveSimBasic*** Variante	PLC Sim Advanced interface	Notes
SIMIT	Siemens	***.fmu	Yes	<ul style="list-style-type: none"> Permissible configuration: ExternalLoad = 1 & . SpeedController = 0 or ExternalLoad = 0 & . SpeedController = 1 Simulation with external load can provide wrong results because the minimum possible time step is 1 ms
Simcenter Amesim	Siemens	***_double.fmu	Yes	
MATLAB Simulink	MathWorks	< 2019a ***_unstruct.fmu ≥ 2019a ***.fmu	Yes	
ANSYS Twin Builder	ANSYS	***.fmu	No	
Hopsan	Linköping University	***_double.fmu	No	<ul style="list-style-type: none"> Open Source Install "win64-with_compiler-installer.exe" package

Selection and ordering data

Description	Artikel-Nr.
SINAMICS DriveSim Basic	6FC6490-1SP10-0AB0

More information

More information is provided on the internet at: <https://support.industry.siemens.com/cs/document/109798225>

You can find more videos on the topic at:

- [Simulation of drive systems - Quick, Easy and Validated](#)
- [Simulation of drive systems - An introduction to SINAMICS](#)
- [Getting started with SINAMICS DriveSim Basic](#)
- [How to import SINAMICS DriveSim Basic into SIMIT, Matlab Simulink, Amesim and ANSYS TwinBuilder](#)
- [How to connect SINAMICS DriveSim Basic via PLCSim Advance to TIA Portal](#)
- [How to use SINAMICS DriveSim Basic for drive sizing with TIA Selection Tool](#)
- [How to visualize drive system behavior in NX Mechatronics Concept Designer](#)

Engineering tools

Siemens Product Configurator

Overview

The Siemens Product Configurator helps you to configure the optimum drive technology products for a number of applications. The product portfolio comprises the full drive technology range of gearbox, motor, converter and connection system as well as corresponding controller with suitable software license. The intuitive user interface in conjunction with product-specific preliminary selectors makes it simple, fast and efficient to configure products. The result is a bill of materials with extensive documentation consisting of technical data sheets, motor characteristic curves, 2D dimensional drawings / 3D CAD models, EPLAN macros and much more. You can order the products directly by transferring the bill of materials to the shopping cart of SiePortal.

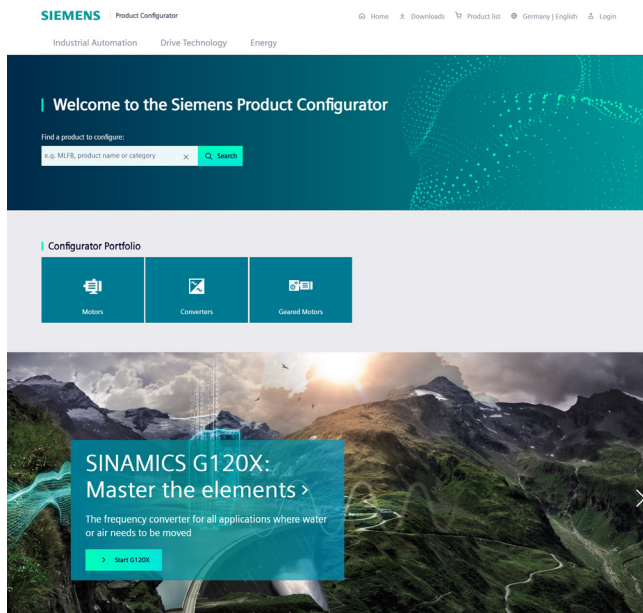

Siemens Product Configurator at a glance

- Quick and easy configuration of drive products and associated components – gearboxes, motors, converters, controllers, connection systems
- Extensive documentation for all products and components, such as
 - Data sheets in up to 12 languages
 - Motor characteristic curves
 - 2D dimensional drawings / 3D CAD models in different formats
 - Terminal box drawing and terminal connection diagram
 - Certificates
 - EPLAN macros
- Ability to order products directly through SiePortal

Access to the Siemens Product Configurator

The Siemens Product Configurator can be accessed without the need for registration or logging in:
www.siemens.com/spc

Overview

Selection guide and configurator for automation technology

Error-free configuration without expert knowledge through intelligent configurators and selection wizards. Desktop and cloud versions enable cross-team collaboration with maximum flexibility.

There are two versions of the TIA Selection Tool:

- One for downloading and execution on Microsoft Windows PCs (from Microsoft Windows 10)
- One for running from the cloud, which is launched from mobile devices directly in the browser (we recommend Safari, Chrome and Firefox)

Projects stored in the cloud can be edited with both tools. This makes it possible to work on-the-go using a tablet, at home on a PC – and vice versa, or together with colleagues and customers.

In order to use the full functionality, we recommended setting up a SiePortal account for both cases. This gives you access to prices and enables you to save your projects to our cloud.

You can find additional information about the TIA Selection Tool at:

www.siemens.com/tia-selection-tool

Drive dimensioning in the TIA Selection Tool

Application-specific requirements can be determined using drive technology dimensioning in the TIA Selection Tool. This can include motors, gearboxes and converters. The tool supports the configuration and dimensioning of control functions with an open and closed control loop. The technical documentation with features of the technical drive system, as well as a product list for ordering via SiePortal can also be compiled.

You can find more information on the SIZER for Siemens Drives engineering tool at

<https://support.industry.siemens.com/cs/ww/en/ps/13434/dl>

Engineering tools

SINAMICS web server for SINAMICS S200

Overview

Web server for efficient commissioning, diagnostics, maintenance and operator control and monitoring, any time, from anywhere

Web server for efficient commissioning, diagnostics, maintenance and operator control and monitoring, any time, from anywhere

Thanks to the web server, the SINAMICS S200 drive system offers an efficient commissioning, diagnostics, maintenance option as well as operation and monitoring functions. The user is supported by a help function and additional links to specific product information, downloads, FAQs and manuals.

The web server provides access to a multi-faceted range of new options for commissioning or parameter assignment, drive diagnostics, remote maintenance as well as operator control and monitoring for any networked PC with a web browser or for tablets and smartphones (via a separate WLAN access point, such as SINAMICS Smart Adapter¹⁾).

The following provides an insight into the functionality offered.

The start screen offers a quick overview of the state of the drive

- Drive type, connected motor as well as the article number and installed firmware
- Important drive parameters show the operating state (can be configured)
- The connection overview provides information about the status of the connections (operating unit - converter - motor)
- Overview of all pending fault and warning messages

Start screen of the web server integrated into SINAMICS S200

Commissioning

- The quick commissioning provides information about the current motor/encoder and offers the configuration of limit values and digital inputs
- Optimization of the drive settings using One Button Tuning (OBT)

Nameplate data	Value	Unit
Rated current	2.4	Arms
Rated speed	3000	rpm
Rated voltage	142	Vrms
Maximum motor speed	6000	rpm
Maximum motor current	8.7	Arms

Optional motor data	Value	Unit
Rated power	0.4	kW
Rated torque	1.27	Nm
Motor stall current	2.4	Arms
Motor stall torque	1.27	Nm
Motor moment of inertia	0.000015	kgm ²

Quick commissioning with open dialog showing the set motor data

Parameter name	Current value	Previous value
P gain	0.0186 Nms/rad	0.0186 Nms/rad
Integral time	5.01 ms	5.01 ms
Load moment of inertia	0.000000 kgm ²	0.000000 kgm ²
Kt factor estimated	21.69 1000 rpm	21.69 1000 rpm
Precontrol system/ing time estimated	0.29 ms	0.29 ms

One Button Tuning (OBT)

¹⁾ SINAMICS Smart Adapter available soon.

Overview

Operator control and monitoring

- Configurable drive status with value or trend display
- Status of the digital inputs
- Drive traversing via the control panel, which can be freely positioned on the screen

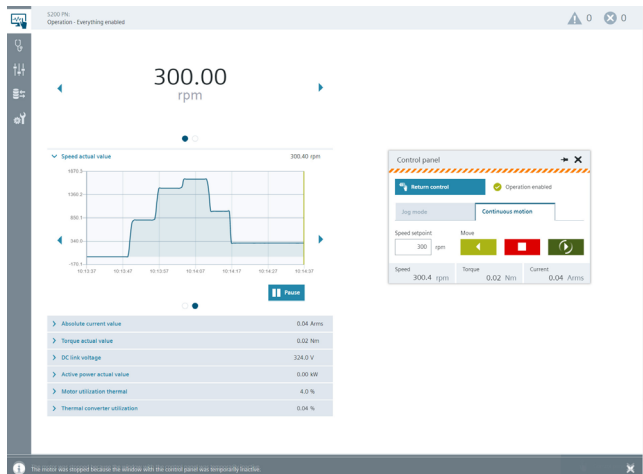

Operator control and monitoring of the drive with the help of the drive status and control panel

Diagnostics

- Evaluation of warnings and fault messages
- Evaluation of system events (diagnostic buffer)
- Analysis of the safety status
- Connection overview, diagnostics of the drive communication and control and status words

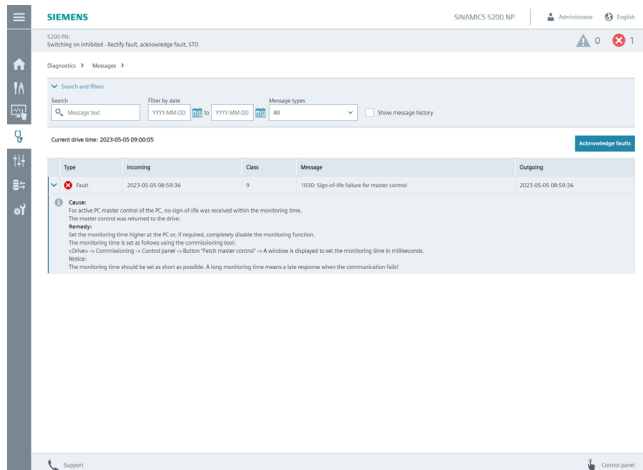

Alarm view with convenient search and filter functions

Service and maintenance functions

- Monitor and adjust drive parameters
- Create, import and export user-specific parameter lists
- Back up and restore the drive configuration
- Perform firmware update, also via the network
- Manage software licenses
- Configure basic settings for the drive and web server (e.g. date and time of the drive)
- Configure and manage user accounts and access controls (UMAC)

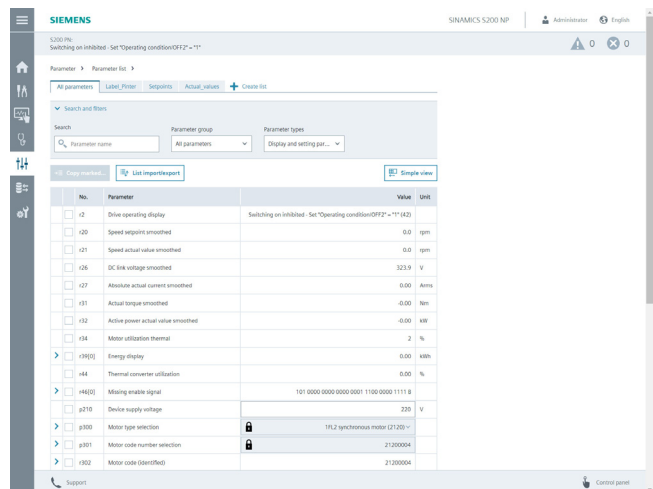

Parameter list for quick access to drive parameters, also via user-defined parameter lists

Engineering tools

SINAMICS web server for SINAMICS S200

Overview

Support

- Operator support with comprehensive information about the drive and user interface
- Easy access to product information such as FAQs, software downloads, manuals and certificates
- When storing the html documentation on the drive memory card, the user manual can be accessed in a context-sensitive manner from the user interface

Support✕

Links to the Siemens Industry Online Support

▼ **General links**

[Produktseite SINAMICS S200](#)

[Siemens Industry Online Support - Startseite](#)

▼ **Produktspezifische Links für SINAMICS S200**

[Produkt-Support](#)

[FAQs](#)

[Software-Downloads](#)

[Manuals / Betriebsanleitung](#)

[Prüfbescheinigungen / Zertifikate](#)

[Produktmitteilung](#)

Link to product information

▼ **Component-specific QR codes** i

Using the QR codes, you can directly navigate to the online Support pages for the individual components. To do this, read in the codes using either a standard code scanner or the Siemens Industry Online Support App. If you use a standard code scanner, open the link in a web browser already installed on your system.

You can obtain the App, for example, for Android through the Google Play store or for iOS through the Apple App store.

[▶ Industry Online Support Mobile App](#)

Component

Converter
▼



Type: SINAMICS S200 PN
 Article number: 6SL5510-1BB10-4AF0
 Serial number: SZVR3103153343

OK

Support dialog for quick access to product-specific information

Benefits

Simple and fast commissioning

- Installation of additional commissioning software is not required.
- Tools required for the commissioning are ready to use via the integrated web server.
- Standard pages to set thresholds and onboard inputs
- Simple controller optimization with One Button Tuning (OBT)
- Extensive online help with context-sensitive access to the Operating Instructions (memory card required)

Shorter machine downtimes

- Quick overview of the current configuration and the state of the drive
- Efficient diagnostics and maintenance
- Understandable diagnostic information and messages, including the causes of issues and possible remedies, are displayed in plain text in multiple languages
- Context-sensitive help with optional access to the web-based device documentation provides quick help with questions about drive functions

Convenient service and maintenance functions

- Quick backup and restoration of the drive data
- Convenient firmware update, also via the network
- Convenient access to drive parameters
- User-defined parameter lists that focus on what matters
- Easy and efficient handling of the parameter list by using search functions and filters (e.g. parameter groups, parameter types)
- Easy exchange with operating personnel by importing/exporting user-defined parameter lists.
- User-defined parameter lists can be exchanged between the SINAMICS Startdrive and the web server.

Direct language selection

- English, French, German, Italian, Spanish, Chinese Simplified

Accessibility

- Via all LAN or PROFINET interfaces
- Use of mobile devices (e.g. notebooks/tablets and smartphones) via WLAN e.g. with SINAMICS Smart Adapter ¹⁾ or a separate access point
- Access to the web server via PCs/notebooks, SIMATIC HMI (> 10"), smartphones/tablets with a Chromium-based internet browser

Access security

- Protection against unauthorized access to the drive functions and data
- Convenient user administration that supports a roles concept
- Easy set-up and management of user accounts

Application

The web server is ideal for applications not requiring any special commissioning software or version dependencies. Commissioning, diagnostics and maintenance as well as operator control and monitoring are possible both locally and remotely, provided appropriate security measures are applied.

¹⁾ SINAMICS Smart Adapter available soon.

Integration

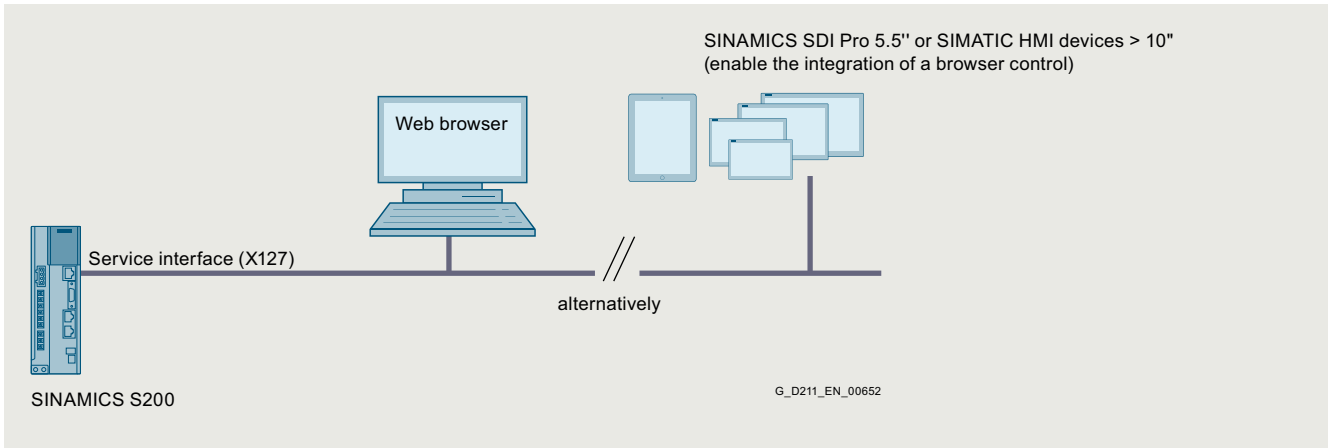

Integration of the SINAMICS web server based on the example of a SINAMICS S200 and the service interface (X127) ¹⁾

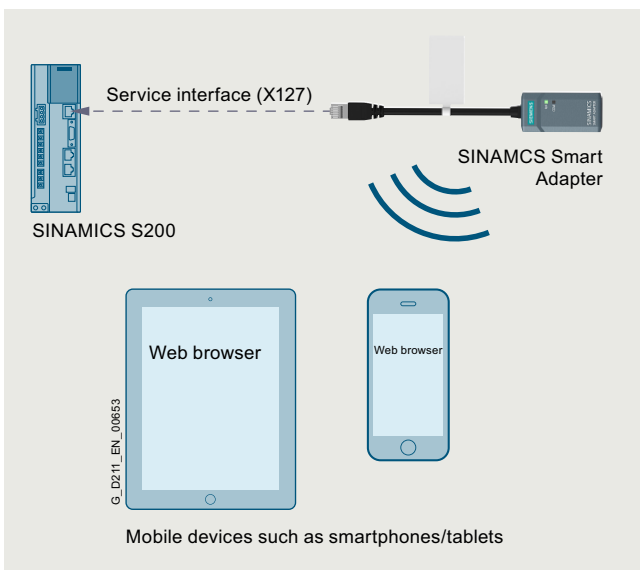

Wireless access to the web server via the service interface (X127) of the SINAMICS S200 with the help of the SINAMICS Smart Adapter ¹⁾

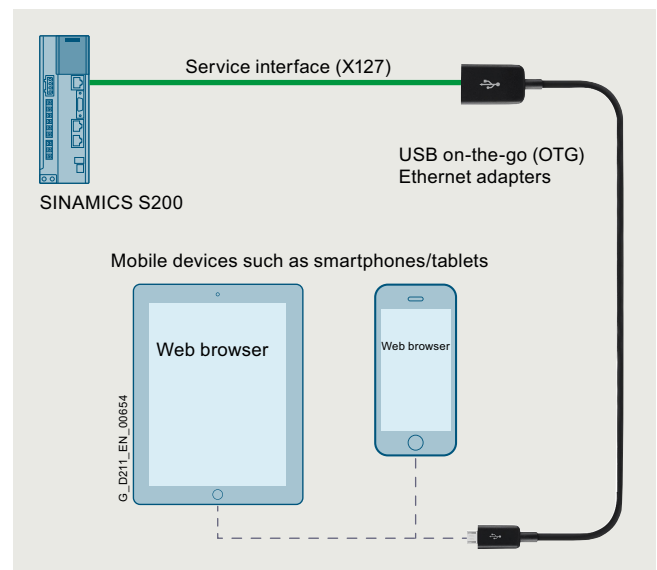

Access to the web server via the service interface (X127) of the SINAMICS S200 with the help of a USB on-the-go (OTG) Ethernet adapter

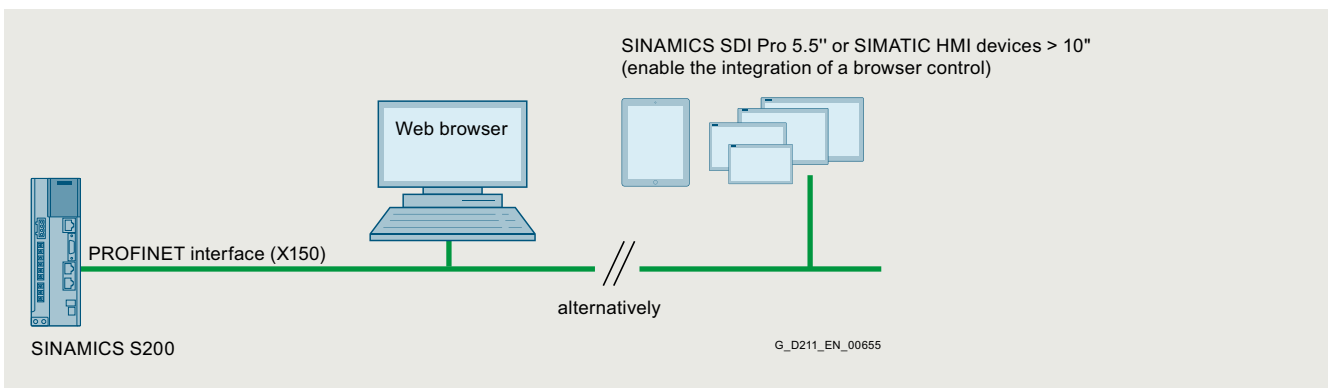

Integration of the SINAMICS web server based on the example of a SINAMICS S200 and the PROFINET interface (X150) as connected web client (e.g. PC, SIMATIC HMI etc.) ¹⁾

¹⁾ SINAMICS Smart Adapter and SINAMICS SDI Pro 5.5" available soon.

Engineering tools

SINAMICS Startdrive commissioning tool

Overview

SINAMICS Startdrive is integrated in the TIA Portal and is a tool for the configuration, commissioning and diagnostics of the SINAMICS family of converters.

The SINAMICS Startdrive commissioning tool has been optimized with regard to user friendliness and consistent use of the TIA Portal benefits of a common working environment for PLC, HMI and drives. Time-saving and guided step-by-step commissioning with maximum flexibility is complemented by user-friendly graphic function views for all drive functions, including functional safety (Safety Integrated) and drive-based technology functions (e.g. EPos). The automatic message display, the powerful real-time trace and the context-sensitive online help make converter diagnostics very easy.

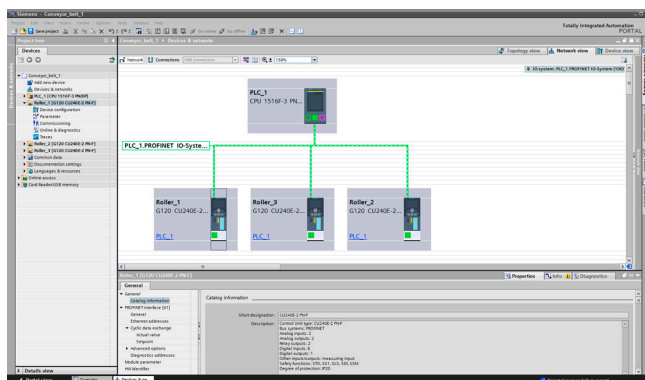

The software packages based on the TIA Portal are harmonized with each other and offer important benefits, the main advantage being a shared project storage. The TIA Portal enables simple integration of SINAMICS converters in your automation solution. Thanks to the standardization of operator actions and the integration in general TIA Portal operating concepts (e.g. UMAC, Openness) as well as standard TIA Portal functions (e.g. Undo/Redo), familiarization is easy both for drive experts as well as SIMATIC users. Special focus is placed on the interaction between SIMATIC and SINAMICS, especially when connecting the SINAMICS drives to SIMATIC technology objects.

Integration

Supported frequency converters

SINAMICS Startdrive Basic enables complete commissioning, diagnostics, parameterization, optimization and connection to the PLC for the following SINAMICS converters integrated in SINAMICS Startdrive:

- SINAMICS G120, G120C, G120D, G120P
- SINAMICS G115D
- SINAMICS G130, G150
- SINAMICS G220 (as of V18 SP2)
- SINAMICS S120 ¹⁾, S150
- SINAMICS S210 and SINAMICS S210 (New) (as of V18 SP1)
- SINAMICS S200 (as of V18 SP2)
- SINAMICS MV

SINAMICS Startdrive Advanced

With SINAMICS Startdrive Advanced (available as of V15) you benefit from powerful engineering functions that save you considerable time and ultimately costs.

- Advanced functions for SINAMICS Startdrive: Safety acceptance test (available for SINAMICS G120, G120C, G115D, G120D, G120P, G130, G150, G220, S120, S150 and S210)
 - Guided acceptance test wizard for all drive-based Safety Integrated functions (Basic, Extended and Advanced Safety)
 - Automatic and safety function-specific generation of traces to analyze the machine behavior
 - Generation of an acceptance report as Excel file (xlsx format, can also be used with OpenOffice)
 - Safety Activation Test
- Improved optimization options in the drive: Extended measuring functions (available for CU320-2 PN/DP and CU310-2 PN as of V5.2 SP3, SINAMICS S210 (New) as of V6.1 and SINAMICS S200 as of V6.2), Trace without trigger condition (ring buffer)
- Also contains all Startdrive Basic functions
- Only license key required, no additional installation

New in V18

Startdrive Basic V18

- Extension for UMAC: Additional function rights for changes to Safety parameters and for the control panel
- Support for station upload for F-PLCs and drives connected via PROFIsafe
- Extension of the SINAMICS MV family: Support for SINAMICS firmware V5.2 SP7
- Extensions for CU320-2 PN/DP and CU310-2 PN-based drive units:
 - Support for linear motors (1FN1, 1FN3 and third-party motors)
 - FFT (Fast Fourier Transformation) analysis of recorded trace signals
- SLS (Safely-Limited Speed) function for SINAMICS G115D (new from V18 SP1)
- Integration of the devices SINAMICS S210 (New) (as of V18 SP1), SINAMICS S200 (as of V18 SP2) and SINAMICS G220 (as of V18 SP2) inclusive new functions:
 - Security Wizard
 - User-defined lists

Startdrive Advanced V18

- Safety Activation Test extension: Recording of selectable signals and states during the test, with transfer to log feature
- Expansion for CU320-2 PN/DP and CU310-2 PN-based drive units: Trace without trigger condition (ring buffer for continuous monitoring of signals)

¹⁾ Including SINAMICS S220 Smart Line Modules in booksize format as of SINAMICS Startdrive V17 Update 1.

Integration

Installation versions

SINAMICS Startdrive can be installed as an optional package to SIMATIC STEP 7 or as a stand-alone application (without SIMATIC STEP 7).

System requirements

The following table shows the recommended hardware and system equipment for the operation of SINAMICS Startdrive.

Hardware	Recommendation
Computer	As of SIMATIC FIELD PG M6 Comfort (or comparable PC)
Processor	Intel Core i5-8400H (2.5 ... 4.2 GHz; 4 cores + hyper-threading; 8 MB Smart Cache)
RAM	16 GB or more (32 GB for large projects)
Hard disk	SSD with at least 50 GB available memory
Screen resolution	15.6" Full HD display (1920 × 1080 or larger)
Operating systems	<ul style="list-style-type: none"> • Microsoft Windows 10 (64 bit) <ul style="list-style-type: none"> - Windows 10 Professional Version 21H1, 21H2 - Windows 10 Enterprise 2009/20H2, 21H1, 21H2 - Windows 10 IoT Enterprise 2016 LTSC - Windows 10 IoT Enterprise 2019 LTSC - Windows 10 IoT Enterprise 2021 LTSC • Microsoft Windows 11 (64 bit) <ul style="list-style-type: none"> - Windows 11 Home Version 21H2 - Windows 11 Professional Version 21H2 - Windows 11 Enterprise 21H2 • Microsoft Windows Server (64 bit) <ul style="list-style-type: none"> - Windows Server 2016 Standard (full installation) - Windows Server 2019 Standard (full installation) - Windows Server 2022 Standard (full installation)

Compatibility with other products

- SINAMICS Startdrive V18 SP2 operates with STEP 7, WinCC and Scout TIA V18 in one framework
- SINAMICS Startdrive V18 SP2 can be installed on the same computer in parallel with other versions of SINAMICS Startdrive V12 to V17
- SINAMICS Startdrive can be installed on the same computer as SINAMICS MICROMASTER STARTER

Supported virtualization platforms

SINAMICS Startdrive can be installed in a virtual machine. For this purpose, one of the following virtualization platforms in the specified version or a newer version can be used:

- Microsoft Windows 10 Professional Version 1909, 2004, 2009/20H2, 21H1, 21H2
- Microsoft Windows 10 Enterprise 1909, 2004, 2009/20H2, 21H1, 21H2
- Microsoft Windows 10 Enterprise 2016 LTSC
- Microsoft Windows 10 Enterprise 2019 LTSC
- Microsoft Windows 10 Enterprise 2021 LTSC

Supported safety programs

The following safety programs have been tested with SINAMICS Startdrive V18:

- Virus scanners:
 - Symantec Endpoint Protection 14.6
 - Trend Micro OfficeScan 14.0
 - McAfee Endpoint Security (ENS) 10.6 and 10.7
 - Microsoft Defender
 - Qihoo 360 "Safe Guard 12.1" + "Virus Scanner"
- Encryption software:
 - Microsoft Bitlocker
- Host-based Intrusion Detection System
 - McAfee Application Control 8.3.3

Selection and ordering data

Description	Article No.
SINAMICS Startdrive Basic V18 SP2 commissioning tool Single license and certificate of license English, French, German, Italian, Spanish, Chinese Simplified	
• On DVD-ROM	6SL3072-4JA02-0XA0
• Software download (email address required for delivery)	6SL3072-4JA02-0XG0
SINAMICS Startdrive Advanced V18 SP2 commissioning tool License key (floating license) English, French, German, Italian, Spanish, Chinese Simplified	
• On DVD-ROM with license key on USB flash drive	6SL3072-4JA02-0XA5
• Software download incl. license key (email address required for delivery)	6SL3072-4JA02-0XG5
Upgrade SINAMICS Startdrive Advanced V15 ... V17 to V18	
• On DVD-ROM with license key on USB flash drive	6SL3072-4JA02-0XE5
• Software download incl. license key (email address required for delivery)	6SL3072-4JA02-0XK5
Software Update Service with SINAMICS Startdrive Advanced in the TIA Portal Delivery is performed according to the number of ordered SUS products (e.g. 10 upgrade license keys (floating license) with 10 DVD-ROMs, 10 USB flash drives, etc.)	
• On DVD-ROM with upgrade license key on USB flash drive	6SL3072-4AA02-0XL8
• Software download incl. license key (email address required for delivery)	6SL3072-4AA02-0XY8

More information

The SINAMICS Startdrive Basic commissioning tool is available free on the internet at www.siemens.com/startdrive

Engineering tools

Notes

Services and documentation

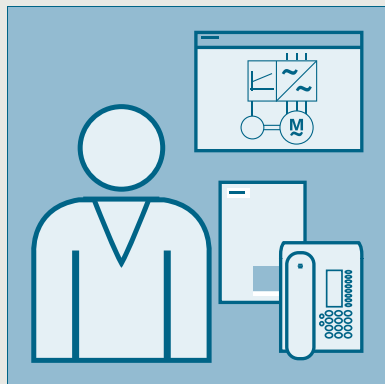

6/2	Partner
6/3	Industry Services
6/4	Industry Services – Portfolio overview
6/5	Online Support
6/6	Training
6/6	SITRAIN – Digital Industry Academy
6/8	SINAMICS S200 training case
6/9	Applications
6/10	mySupport documentation
6/11	Documentation
6/12	General documentation
6/12	SINAMICS S200 documentation

Services and documentation

Partner

Partner at Siemens

At your service locally, around the globe for consulting, sales, training, service, support, spare parts on the entire portfolio of Siemens.

Your partner can be found in our Personal Contacts Database at: www.siemens.com/automation-contact

You start by selecting

- the required competence,
- products and branches,
- a country and a city

or by a

- location search or free text search.

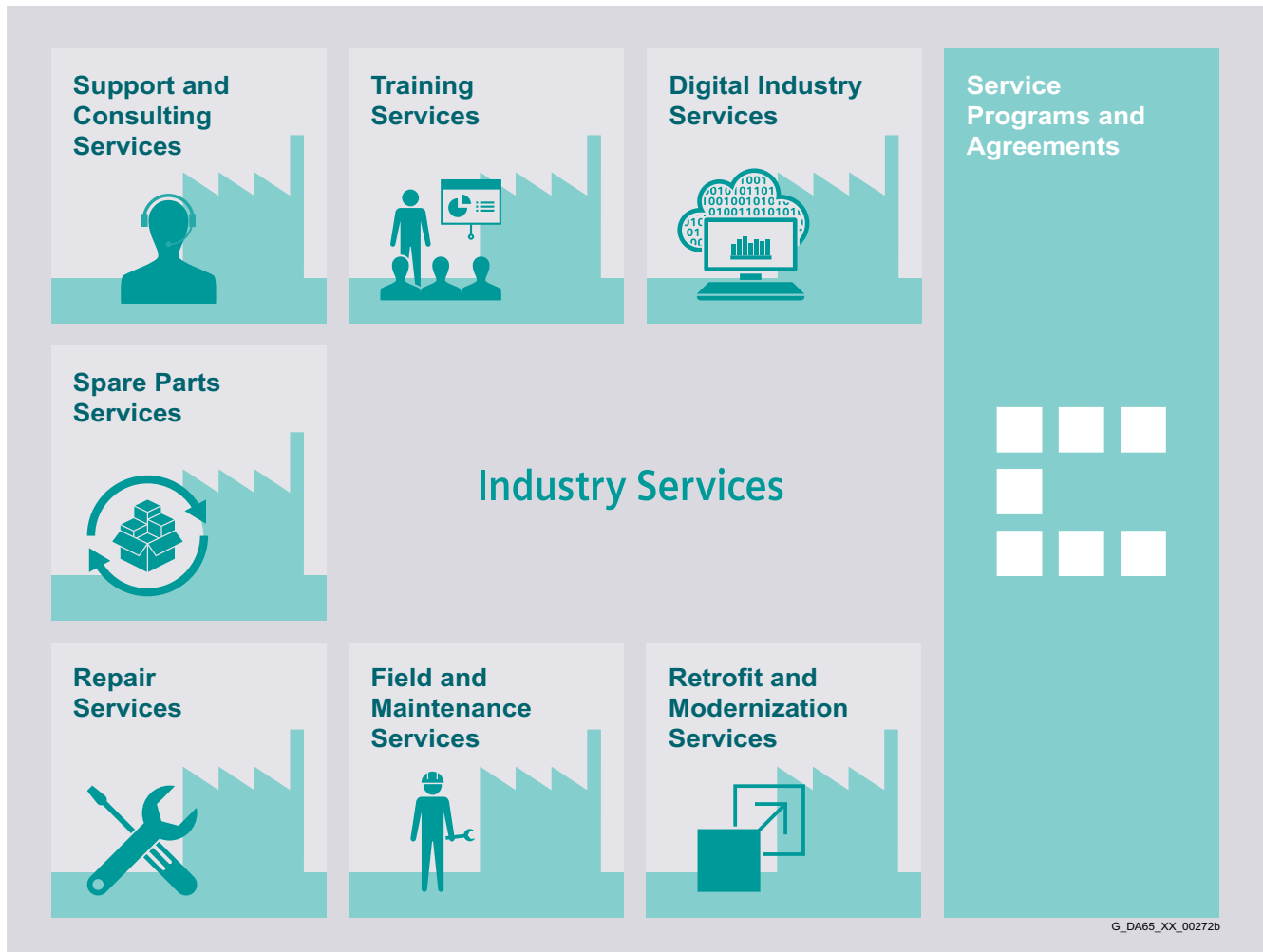
Overview

Keep your business running and shaping your digital future – with Industry Services

Optimizing the productivity of your equipment and operations can be a challenge, especially with constantly changing market conditions. Working with our service experts makes it easier. We understand your industry's unique processes and provide the services needed so that you can better achieve your business goals.

You can count on us to maximize your uptime and minimize your downtime, increasing your operations' productivity and reliability. When your operations have to be changed quickly to meet a new demand or business opportunity, our services give you the flexibility to adapt. Of course, we take care that your production is protected against cyber threats. We assist in keeping your operations as energy and resource efficient as possible and reducing your total cost of ownership. As a trendsetter, we ensure that you can capitalize on the opportunities of digitalization and by applying data analytics to enhance decision making: You can be sure that your plant reaches its full potential and retains this over the longer lifespan.

You can rely on our highly dedicated team of engineers, technicians and specialists to deliver the services you need – safely, professionally and in compliance with all regulations. We are there for you, where you need us, when you need us.

www.siemens.com/industryservices

Services and documentation

Industry Services

Industry Services – Portfolio overview

Overview



Digital Industry Services

Digital Industry Services make your industrial processes transparent to gain improvements in productivity, asset availability, and energy efficiency.

Production data is generated, filtered and translated with intelligent analytics to enhance decision-making.

This is done whilst taking data security into consideration and with continuous protection against cyber-attack threats.

www.siemens.com/global/en/products/services/industry/digital-industry-services.html



Training Services

From the basics and advanced to specialist skills, SITRAIN courses provide expertise right from the manufacturer – and encompass the entire spectrum of Siemens products and systems for the industry.

Worldwide, SITRAIN courses are available wherever you need a training course in more than 170 locations in over 60 countries.

<https://support.industry.siemens.com/cs/ww/en/sc/2226>



Support and Consulting Services

Industry Online Support site for comprehensive information, application examples, FAQs and support requests.

Technical and Engineering Support for advice and answers for all inquiries about functionality, handling, and fault clearance. The Service Card as prepaid support for value added services such as Priority Call Back or Extended Support offers the clear advantage of quick and easy purchasing.

Information & Consulting Services, e.g. SIMATIC System Audit; clarity about the state and service capability of your automation system or Lifecycle Information Services; transparency on the lifecycle of the products in your plants.

<https://support.industry.siemens.com/cs/ww/en/sc/2235>



Spare Parts

Spare Parts Services are available worldwide for smooth and fast supply of spare parts – and thus optimal plant availability. Genuine spare parts are available for up to ten years. Logistic experts take care of procurement, transport, custom clearance, storage and order manage-

ment. Reliable logistics processes ensure that components reach their destination as needed.

Since not all spare parts can be kept in stock at all times, Siemens offers a preventive measure for spare parts provisioning on the customer's premises with optimized **Spare Parts Packages** for individual products, custom-assembled drive components and entire integrated drive trains – including risk consulting.

Asset Optimization Services help you design a strategy for parts supply where your investment and carrying costs are reduced and the risk of obsolescence is avoided.

<https://support.industry.siemens.com/cs/ww/en/sc/2110>



Repair Services

Repair Services are offered on-site and in regional repair centers for fast restoration of faulty devices' functionality.

Also available are extended repair services, which include additional diagnostic and repair measures, as well as emergency services.

<https://support.industry.siemens.com/cs/ww/en/sc/2154>



Field and Maintenance Services

Siemens specialists are available globally to provide expert field and maintenance services, including commissioning, functional testing, preventive maintenance and fault clearance.

All services can be included in customized service agreements with defined reaction times or fixed maintenance intervals.

<https://support.industry.siemens.com/cs/ww/en/sc/2265>



Retrofit and Modernization Services

Provide a cost-effective solution for the expansion of entire plants, optimization of systems or upgrading existing products to the latest technology and software, e.g. migration services for automation systems.

Service experts support projects from planning through commissioning and, if desired over the entire extended lifespan, e.g. Retrofit for Integrated Drive Systems for an extended lifetime of your machines and plants.

<https://support.industry.siemens.com/cs/ww/en/sc/2286>



Service Programs and Agreements

A technical Service Program or Agreement enables you to easily bundle a wide range of services into a single annual or multi-year agreement.

You pick the services you need to match your unique requirements or fill gaps in your organization's maintenance capabilities.

Programs and agreements can be customized as KPI-based and/or performance-based contracts.

<https://support.industry.siemens.com/cs/ww/en/sc/2275>

Overview

Online Support – fast, intuitive, whenever you want, wherever you need

Web
www.siemens.com/online-support

App

GET IT ON Google Play | Learn on the App Store | Herunterladen von Microsoft

Scan the QR code for information on our Online Support app.

FAQ / Application examples
Information about industrial products, programming and configuration as well as application examples

Technical information
Videos, documentation, manuals, updates, product notes, compatibility tool, certificates, planning data such as dimensional drawings, product data, 3D models

Forum
Exchange information and experience with other users and experts

Online Support for Siemens Industry Products

Siemens Industry and Online Support with some 1.7 million visitors per month is one of the most popular web services provided by Siemens. It is the central access point for comprehensive technical know-how about products, systems and services for automation and drives applications as well as for process industries.

In connection with the challenges and opportunities related to digitalization you can look forward to continued support with innovative offerings.

Services and documentation

Training

SITRAIN – Digital Industry Academy

Introduction



SITRAIN – DIGITAL INDUSTRY ACADEMY
The Future of Learning starts now

SITRAIN - Digital Industry Academy stands for a modern learning culture that focuses on the needs of learners and the demands of innovative companies.

SITRAIN offers a comprehensive range of knowledge on Siemens industrial products and, under the vision "Future of Learning", pursues a holistic approach that combines different forms and methods of learning. Different learning formats allow for more effective, flexible and continuous learning depending on the type of learning.

Education and training directly from the manufacturer



Industrial Automation Systems SIMATIC

Training available for: SIMATIC S7-1500, TIA Portal, SIMATIC S7-300/400, SIMATIC S7-1200



Drive Technology

Training available for: SINAMICS S120 and SINAMICS G120 low-voltage converters, SINAMICS G130 / G150 / G180 / S150



SINUMERIK CNC automation system

Training available for: SINUMERIK 840D, SINUMERIK 840D sl and SINUMERIK ONE



Process Control Systems

Training available for: SIMATIC PCS 7, SIMATIC PCS neo



Digital Enterprise

Training available for: Openness, SIMIT, OPC UA, Industrial Edge, Virtual commissioning



Industrial Communications

Training available for: PROFINET, SCALANCE, RUGGEDOM, Industrial Ethernet, Fieldbus communication, Industrial Security, Remote communication

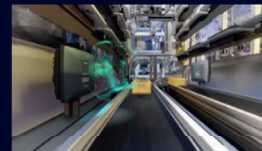

Identification and Locating

Training available for: RFID, RTLS-Systems



Operator Control and Monitoring Systems

Training available for: SIMATIC WinCC Unified in TIA Portal, SIMATIC WinCC in TIA Portal, SIMATIC WinCC V7x



Motion Control System SIMOTION

Training available for: SIMOTION (Programming, Commissioning, Diagnostics, Service)



Smart Infrastructure

Training available for: SIRIUS, SENTRON, SIVACON, ALPHA, SIMOCODE, Circuit breakers



Process Analytics & Instrumentation

Training is available for process analytics and instrumentation, explosion protection, process gas chromatographs



Additional training offer

SIMOVE with Automated Guided Vehicles (AGV), SIPLUS CMS, Guidelines and standards for control cabinets

Introduction**Different learning formats and methods for maximum learning success**

Face-to-face training in the training center or in the virtual classroom, with fixed dates and course times, learning in a group with a learning guide? Or digital training, on your own responsibility and location-independent, on demand, 24/7?

With the learning formats "Learning Journey", "Learning Membership" and "Learning Event", SITRAIN offers a wide range of different learning options in connection with didactically effective methods and modular possibilities.

**Learning Journey**

The combination for sustainable learning success

- The optimal mix of self-study units and guided live modules
- Includes a Learning Membership to work through the self-study modules and access on-demand content
- The SITRAIN learning consultant is available for questions and one-on-one consultations
- Ideal integration into the daily work routine and adaptation to one's own learning pace.

**Learning Membership**

Securing knowledge through continuous learning on your own responsibility

- With access to the comprehensive and constantly growing range of self-study units on SITRAIN access, the digital learning platform
- Search and find specific learning content or simply have a look around – anytime and anywhere
- A modern learning culture through continuous learning on your own responsibility and transparency about your learning success in the team or company.

**Learning Event**

Acquire theoretical and practical knowledge in a compact and guided format

- You achieve a defined learning goal in the shortest possible time
- The learning consultant guides you through the practical exercises and is also exclusively available to you during the theoretical sessions for the entire duration
- Focused learning, outside of the daily work routine, in a protected learning environment – virtually, in the training center, or at your company.

**Live**

Learn together with others, simultaneously and guided by a learning consultant. Online, in the SITRAIN training center or at your company.

**Self-reliant**

Expand your knowledge self-determined with industry learning and work on your learning units at your own pace and according to your own schedule.

**On demand**

Get the knowledge you need, exactly when you need it. Be it to answer a current question or to work on a special topic.

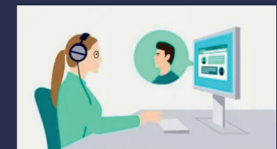
**Individuell**

Talk directly with the learning consultant, clarify detailed questions and get personal coaching for transferring the learned topics to your own application.

**Training cases catalog**

<https://www.siemens.com/sitRAIN-catalog-training-cases>

Find
your local
offer here

**SITRAIN – Digital Industry Academy worldwide**

You will find the regional knowledge offer in the country selection. One click will take you to the corresponding website.

Services and documentation

Training

SINAMICS S200 training case

Selection and ordering data

Description	Article No.
SINAMICS S200 training case	available soon
Scope of delivery:	
<ul style="list-style-type: none">• 2 x SINAMICS S200 servo converter, PROFINET version, 200 V, 100 W• 1 x SIMOTICS S-1FL2 Low Inertia servomotor, absolute encoder 21-bit singleturn• 1 x SIMOTICS S-1FL2 Low Inertia servomotor, absolute encoder 21-bit singleturn + 12-bit multiturn• 2 x Pre-assembled dual motor connection cable• Rail, prepared for installation of a controller, e.g. SIMATIC S7-1500 (controller not included in scope of delivery)	
The SINAMICS S200 training case is supplied as a trolley with a hood.	

Overview



Our understanding of an application is the customer-specific solution of an automation task based on standard hardware and software components. In this respect, industry knowledge and technological expertise are just as important as expert knowledge about how our products and systems work. We are setting ourselves this challenge with more than 280 application engineers in 20 countries.

Application centers

We currently have application centers in:

- Germany: Head Office in Erlangen and in other German regions, e.g. in Munich, Nuremberg, Stuttgart, Mannheim, Frankfurt, Chemnitz, Cologne, Bielefeld, Bremen, Hanover, Hamburg
- Belgium: Brussels
- Brazil: Sao Paulo
- China: Beijing and 12 regions
- Denmark: Ballerup
- France: Paris
- Great Britain: Manchester
- India: Mumbai
- Italy: Bologna, Milan
- Japan: Tokyo, Osaka
- The Netherlands: The Hague
- Austria: Vienna
- Poland: Warsaw
- Sweden: Göteborg
- Switzerland: Zurich, Lausanne
- Spain: Madrid
- South Korea: Seoul
- Taiwan: Taipei
- Turkey: Istanbul
- USA: Atlanta

These application centers specialize in the use of SIMATIC/SIMOTION/SINAMICS. You therefore can rely on automation and drive specialists for implementing successful applications. By involving your personnel at an early stage in the process, we can provide a solid basis for rapid knowledge transfer, maintenance and further development of your automation solution.

Advice on applications and implementation

We offer a variety of consultation services to help you find the optimum solution for the SIMATIC/SIMOTION/SINAMICS application you want to implement:

The quotation phase includes

- clarification of technical questions,
- discussion of machine concepts and customer-specific solutions,
- selection of suitable technology and
- suggestions for implementation.

A technical feasibility study is also performed at the outset. In this way, difficult points of the application can be identified and solved early on. We can also configure and implement your application as a complete solution from a single source.

A large number of proven standard applications are available for use during the implementation phase. This saves engineering costs.

The system can be commissioned by experienced, competent personnel, if required. This saves time and trouble.

If servicing is required, we can support you on site or remotely. For further information about servicing, please see the section "Industry Services".

On-site application training

Training for the implemented applications can also be organized and carried out on site. This training for machine manufacturers and their customers does not deal with individual products, but the entire hardware and software system (for example, automation, drives and visualization).

From an initial concept to successful installation and commissioning: We provide complete support for SIMATIC/SIMOTION/SINAMICS! Contact your Siemens representative.

You can find further information at www.siemens.com/machinebuilding

Services and documentation

mySupport documentation

Overview

mySupport documentation – Compiling personal documents

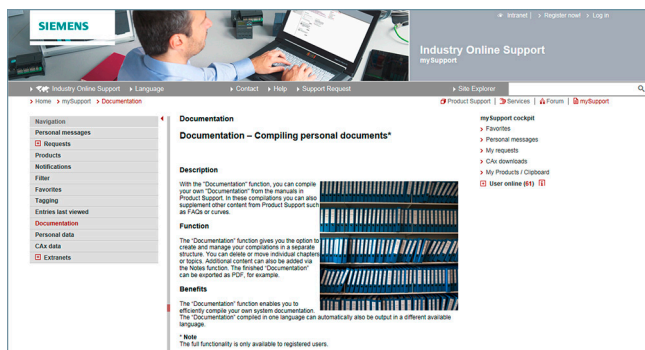

mySupport documentation is a web-based system for generating personalized documentation based on standard documents and is part of the Siemens Industry Online Support portal.

In mySupport, a personal document library can be created in the "Documentation" category. This library can be accessed online in mySupport or also be generated in various formats for offline use.

Previously, this functionality was available in the My Documentation Manager for configurable manuals. Due to the integration in mySupport, all entries of the Industry Online Support can now be imported into the personal document library, including FAQs or product notifications.

If you have already worked with the My Documentation Manager, all of the previously created libraries will continue to be available without restrictions in mySupport.

In addition, the personal library in mySupport can be shared with other mySupport users. In this way, a collection of relevant documents can be created very effectively and used together with other mySupport users all over the world.

You must register/log in for configuring and generating/managing.

Benefits

- Display
View, print or download standard documents or personalized documents
- Configure
Transfer standard documents or parts of them to personalized documents
- Generate/Manage
Generate and manage personalized documents in the formats PDF, RTF or XML in all available languages

Function

Opening mySupport documentation in the Industry Online Support portal

- Via the product support, entry type "Manual":
<https://support.industry.siemens.com/cs/ww/en/ps/manual>
By clicking on the required version of the manual and then "Show and configure", the manual opens in a modular view, where you can navigate from topic to topic. Here the direct link to a topic can be used and made available to other users. The selected document can be added to the personal library via "mySupport Cockpit" > "Add to mySupport documentation".
- Via the direct link
<https://support.industry.siemens.com/my/ww/en/documentation/advanced>
After logon/registration, the online help is displayed as the current document.

More information

You can find additional information on the internet at

- <https://support.industry.siemens.com/my/ww/en/documentation>
- https://support.industry.siemens.com/cs/helpcenter/en/index.htm?#persoenliche_bibliothek_aufbauen.htm

Overview

A high-quality programmable control or drive system can be used to maximum effect only if the user is aware of the performance of the products used as a result of intensive training and good technical documentation.

This is becoming more important due to the shorter innovation cycles of modern automation products and the convergence of electronics and mechanical engineering.

A comprehensive range of documentation is available which includes a Getting Started guide, operating instructions, installation manuals and a list manual.

The documents are available in hardcopy form or as a PDF file for downloading from the internet.

Information and documentation relating to SINUMERIK, SINAMICS, SIMOTION and SIMOTICS are available on the internet at <https://support.industry.siemens.com/cs/document/109476679>

Application

Explanations of the manuals:

- **Operating Instructions**
contain all the information needed to install the device and make electrical connections, information about commissioning and a description of the converter functions.
Phases of use: Control cabinet construction, commissioning, operation, maintenance and servicing.
- **Hardware Installation Manual**
contains all relevant information about the intended use of the components of a system (technical specifications, interfaces, dimensional drawings, characteristics, or possible applications), information about installation and electrical connections and information about maintenance and servicing.
Phases of use: Control cabinet configuration/construction, maintenance and servicing.
- **Operating and Installation Instructions** (for converter and accessories)
contain all relevant information about the intended use of the components, such as technical specifications, interfaces, dimensional drawings, characteristics, or possible applications.
Phases of use: Control cabinet configuration/construction.
- **Manual/Configuration Manual**
contains all necessary information about the intended use of the components of a system, e.g. technical specifications, interfaces, dimensional drawings, characteristics, or possible applications.
Phases of use: Cabinet configuration/setup, circuit diagram configuration/drawing.
- **Commissioning Manual**
contains all information relevant to commissioning after installation and wiring. It also contains all safety and warning notices relevant to commissioning in addition to overview drawings.
Phases of use: Commissioning of components that have already been connected, configuration of system functions.
- **List Manual**
contains all parameters, function diagrams, and faults/alarms for the product/system as well as their meanings and setting options. It contains parameter data and fault/alarm descriptions with functional correlations.
Phases of use: Commissioning of components that have already been connected, configuration of system functions, fault cause/diagnosis.
- **Getting Started**
provides information about getting started for the first-time user as well as references to additional information. It contains information about the basic steps to be taken during commissioning. The information in the other documentation should be carefully observed for all of the other work required.
Phases of use: Commissioning of components that have already been connected.
- **Function Manual Drive Functions**
contains all the relevant information about individual drive functions: Description, commissioning and integration in the drive system.
Phases of use: Commissioning of components that have already been connected, configuration of system functions.

Services and documentation

Documentation

General documentation

Overview

Description	Article No.
Decentralization with PROFIBUS DP/DPV1 <ul style="list-style-type: none"> • German • English 	Via bookstore ISBN 978-3-89578-189-6 ISBN 978-3-89578-218-3
Automating with PROFINET: Industrial Communication Based on Industrial Ethernet <ul style="list-style-type: none"> • German • English 	Via bookstore ISBN 978-3-89578-293-0 ISBN 978-3-89578-294-7

SINAMICS S200 documentation

Overview

Identification link according to IEC 61406 for SINAMICS S200

The ID link contains the article and serial number of the product. As a QR code, it replaces the previous data matrix code on the nameplate and takes you with the URL directly to a product information page on the internet with access to the technical documentation, data sheet, certificates, FAQs, product notifications, and catalogs. Paper package inserts become superfluous since the information is available electronically directly via the QR code, even years later. In this way, we are making a valuable contribution to the preservation of our environment. You don't need an additional app. Simply scan the QR code with your smartphone or tablet. According to IEC 61406, the QR code of an ID link is marked with a frame and a triangle at the bottom right.

With their globally unique identifiers, Siemens products are ready for Industry 4.0.

The ID serves as a connection to the administration shell with which modules of the digital twin can be provided.

Further documentation, such as the operating instructions, is available free on the internet at:

www.siemens.com/sinamics-s200/documentation

Detailed information on the SINAMICS S200 drive system, including the latest technical documentation (brochures, tutorials, dimensional drawings, certificates, manuals and operating instructions), is available on the internet at:

www.siemens.com/sinamics-s200

and is also available via the Siemens Product Configurator on the internet.

The Siemens Product Configurator can be found in SiePortal at the following address:

www.siemens.com/sinamics-s200/configuration

Appendix



7/2	Certificates of suitability
7/4	Software licenses
7/6	Conversion tables
7/8	Metal surcharges
7/11	Conditions of sale and delivery

Appendix

Certificates of suitability







Overview

Many of the products in this Catalog fulfill requirements, e.g. for UL, CSA or FM and are labeled with the corresponding approval designation.

All of the certificates of suitability, approvals, certificates, declarations of conformity, test certificates, e.g. CE, UL, Safety Integrated etc. have been performed with the associated system components as they are described in the Catalogs and Configuration Manuals.





The certificates are only valid if the products are used with the described system components, are installed according to the Installation Guidelines and used for their intended purpose.

In other cases, the vendor of these products is responsible for arranging for the issue of new certificates.

Test code	Tested by	Device series/ Component	Test standard	Product category/ File-No.
UL: Underwriters Laboratories <i>Independent public testing body in North America</i>				
	UL according to UL standard	SINUMERIK	Standard UL 508, CSA C22.2 No. 142	NRAQ/7.E164110 NRAQ/7.E217227
		SIMOTION	Standard UL 508, CSA C22.2 No. 142	NRAQ/7.E164110
	UL according to CSA standard	SINAMICS	Standard UL 508, 508C, 61800-5-1 CSA C22.2 No. 142, 274	NRAQ/7.E164110, NMMS/2/7/8.E192450, NMMS/7.E203250, NMMS/7.E214113, NMMS/7.E253831
				NMMS/2/7/8.E121068 NMMS/7.E355661 NMMS/7.E323473
	UL according to UL and CSA standards	SIMODRIVE	Standard UL 508C, CSA C22.2 No. 274	NMMS/2/7/8.E192450 NMMS/7.E214113
	UL according to UL standard	SIMOTICS	Standard UL 1004-1, 1004-6, 1004-8, CSA C22.2 No. 100	PRGY2/8.E227215 PRHZ2/8.E93429 PRHJ2/8.E342747 PRGY2/8.E253922 PRHZ2/8.E342746
	UL according to CSA standard	Line/motor reactors	Standard UL 508, 506, 5085-1, 5085-2, 1561, CSA C22.2 No. 14, 47, 66.1-06, 66.2-06	XQNX2/8.E257859 NMTR2/8.E219022 NMMS2/8.E333628 XPTQ2/8.E257852 XPTQ2/8.E103521 NMMS2/8.E224872 XPTQ2/8.E354316 XPTQ2/8.E198309 XQNX2/8.E475972
	UL according to UL and CSA standards	Line filters, dv/dt filters, sine-wave filters	UL 1283, CSA C22.2 No. 8	FOKY2/8.E70122
		Resistors	UL 508, 508C, CSA C22.2 No. 14, 274	NMTR2/8.E224314 NMMS2/8.E192450 NMTR2/8.E221095 NMTR2/8.E226619
TUV: TÜV Rheinland of North America Inc. <i>Independent public testing body in North America, Nationally Recognized Testing Laboratory (NRTL)</i> TÜV: TÜV SÜD Product Service <i>Independent public testing body in Germany, Nationally Recognized Testing Laboratory (NRTL) for North America</i>				
	TUV according to UL and CSA standards	SINAMICS	NRTL listing according to standard UL 508C	U7V 12 06 20078 013 U7 11 04 20078 009 U7 11 04 20078 010 U7 11 04 20078 011
		SIMOTION	NRTL listing according to standard UL 508	U7V 13 03 20078 01
		SIMODRIVE	NRTL listing according to standard UL 508C, CSA C22.2. No. 14	CU 72090702
		Motion Control Encoder	NRTL listing according to UL 61010-1 CSA C22.2 No. 61010-1	U8V 10 06 20196 024

Certificates of suitability

Overview

Test code	Tested by	Device series/ Component	Test standard	Product category/ File-No.
CSA: Canadian Standards Association <i>Independent public testing body in Canada</i>				
	CSA according to CSA standard	SINUMERIK	Standard CSA C22.2 No. 142	2252-01 : LR 102527
FMRC: Factory Mutual Research Corporation <i>Independent public testing body in North America</i>				
	FM according to FM standard	SINUMERIK	Standard FMRC 3600, FMRC 3611, FMRC 3810, ANSI/ISA S82.02.1	–
EAC: Ivanovo-Certificate <i>Independent public testing body in the Russian Federation</i>				
	EAC in accordance with the EAC Directive	SINAMICS SINUMERIK SIMOTION	Standard IEC 61800-5-1/-2, IEC 61800-3	–
RCM: Australian Communications and Media Authority <i>Independent public testing body in Australia</i>				
	RCM according to EMC standard	SINAMICS SINUMERIK SIMOTION	Standard IEC AS 61800-3, EN 61800-3	–
KC: National Radio Research Agency <i>Independent public testing body in South Korea</i>				
	KC according to EMC standard	SINAMICS SINUMERIK SIMOTION	Standard KN 11	–
BIA <i>Federal Institute for Occupational Safety</i>				
–	Functional safety	SINAMICS SINUMERIK SIMOTION	Standard EN 61800-5-2	–
TÜV SÜD Rail				
–	Functional safety	SINAMICS SINUMERIK SIMOTION	Standard EN 61800-5-2	–

More information about certificates can be found online at:
<https://support.industry.siemens.com/cs/ww/en/ps/cert>

Appendix

Software licenses

Overview

Software types

Software requiring a license is categorized into types. The following software types have been defined:

- Engineering software
- Runtime software

Engineering software

This includes all software products for creating (engineering) user software, e.g. for configuring, programming, parameterizing, testing, commissioning or servicing.

Data generated with engineering software and executable programs can be duplicated for your own use or for use by third-parties free-of-charge.

Runtime software

This includes all software products required for plant/machine operation, e.g. operating system, basic system, system expansions, drivers, etc.

The duplication of the runtime software and executable programs created with the runtime software for your own use or for use by third-parties is subject to a charge.

You can find information about license fees according to use in the ordering data (e.g. in the catalog). Examples of categories of use include per CPU, per installation, per channel, per instance, per axis, per control loop, per variable, etc.

Information about extended rights of use for parameterization/configuration tools supplied as integral components of the scope of supply can be found in the readme file supplied with the relevant product(s).

License types

Siemens Industry Automation & Drive Technologies offers various types of software license:

- Floating license
- Single license
- Rental license
- Rental floating license
- Trial license
- Demo license
- Demo floating license

Floating license

The software may be installed for internal use on any number of devices by the licensee. Only the concurrent user is licensed. The concurrent user is the person using the program. Use begins when the software is started. A license is required for each concurrent user.

Single license

Unlike the floating license, a single license permits only one installation of the software per license.

The type of use licensed is specified in the ordering data and in the Certificate of License (CoL). Types of use include for example per instance, per axis, per channel, etc.

One single license is required for each type of use defined.

Rental license

A rental license supports the "sporadic use" of engineering software. Once the license key has been installed, the software can be used for a specific period of time (the operating hours do not have to be consecutive).

One license is required for each installation of the software.

Rental floating license

The rental floating license corresponds to the rental license, except that a license is not required for each installation of the software. Rather, one license is required per object (for example, user or device).

Trial license

A trial license supports "short-term use" of the software in a non-productive context, e.g. for testing and evaluation purposes. It can be transferred to another license.

Demo license

The demo license support the "sporadic use" of engineering software in a non-productive context, for example, use for testing and evaluation purposes. It can be transferred to another license. After the installation of the license key, the software can be operated for a specific period of time, whereby usage can be interrupted as often as required.

One license is required per installation of the software.

Demo floating license

The demo floating license corresponds to the demo license, except that a license is not required for each installation of the software. Rather, one license is required per object (for example, user or device).

Certificate of License (CoL)

The CoL is the licensee's proof that the use of the software has been licensed by Siemens. A CoL is required for every type of use and must be kept in a safe place.

Downgrading

The licensee is permitted to use the software or an earlier version/release of the software, provided that the licensee owns such a version/release and its use is technically feasible.

Delivery versions

Software is constantly being updated. The following delivery versions

- PowerPack
- Upgrade

can be used to access updates.

Existing bug fixes are supplied with the ServicePack version.

PowerPack

PowerPacks can be used to upgrade to more powerful software. The licensee receives a new license agreement and CoL (Certificate of License) with the PowerPack. This CoL, together with the CoL for the original product, proves that the new software is licensed.

A separate PowerPack must be purchased for each original license of the software to be replaced.

Upgrade

An upgrade permits the use of a new version of the software on the condition that a license for a previous version of the product is already held.

The licensee receives a new license agreement and CoL with the upgrade. This CoL, together with the CoL for the previous product, proves that the new version is licensed.

A separate upgrade must be purchased for each original license of the software to be upgraded.

Overview

ServicePack

ServicePacks are used to debug existing products. ServicePacks may be duplicated for use as prescribed according to the number of existing original licenses.

License key

Siemens Industry Automation & Drive Technologies supplies software products with and without license keys.

The license key serves as an electronic license stamp and is also the "switch" for activating the software (floating license, rental license, etc.).

The complete installation of software products requiring license keys includes the program to be licensed (the software) and the license key (which represents the license).

Software Update Service (SUS)

As part of the SUS contract, all software updates for the respective product are made available to you free of charge for a period of one year from the invoice date. The contract will automatically be extended for one year if it is not canceled three months before it expires.

The possession of the current version of the respective software is a basic condition for entering into an SUS contract.

You can download explanations concerning license conditions from https://mall.industry.siemens.com/legal/ww/en/terms_of_trade_en.pdf

Appendix

Conversion tables

Rotary inertia (to convert from A to B, multiply by entry in table)

A \ B	lb-in ²	lb-ft ²	lb-in-s ²	lb-ft-s ² slug-ft ²	kg-cm ²	kg-cm-s ²	gm-cm ²	gm-cm-s ²	oz-in ²	oz-in-s ²
lb-in ²	1	6.94×10^{-3}	2.59×10^{-3}	2.15×10^{-4}	2.926	2.98×10^{-3}	2.92×10^3	2.984	16	4.14×10^{-2}
lb-ft ²	144	1	0.3729	3.10×10^{-2}	421.40	0.4297	4.21×10^5	429.71	2304	5.967
lb-in-s ²	386.08	2.681	1	8.33×10^{-2}	1.129×10^3	1.152	1.129×10^6	1.152×10^3	6.177×10^3	16
lb-ft-s ² slug-ft ²	4.63×10^3	32.17	12	1	1.35×10^4	13.825	1.355×10^7	1.38×10^4	7.41×10^4	192
kg-cm ²	0.3417	2.37×10^{-3}	8.85×10^{-4}	7.37×10^{-5}	1	1.019×10^{-3}	1000	1.019	5.46	1.41×10^{-2}
kg-cm-s ²	335.1	2.327	0.8679	7.23×10^{-2}	980.66	1	9.8×10^5	1000	5.36×10^3	13.887
gm-cm ²	3.417×10^{-4}	2.37×10^{-6}	8.85×10^{-7}	7.37×10^{-8}	1×10^{-3}	1.01×10^{-6}	1	1.01×10^{-3}	5.46×10^{-3}	1.41×10^{-5}
gm-cm-s ²	0.335	2.32×10^{-3}	8.67×10^{-4}	7.23×10^{-5}	0.9806	1×10^{-3}	980.6	1	5.36	1.38×10^{-2}
oz-in ²	0.0625	4.34×10^{-4}	1.61×10^{-4}	1.34×10^{-5}	0.182	1.86×10^{-4}	182.9	0.186	1	2.59×10^{-3}
oz-in-s ²	24.13	0.1675	6.25×10^{-2}	5.20×10^{-3}	70.615	7.20×10^{-2}	7.09×10^4	72.0	386.08	1

Torque (to convert from A to B, multiply by entry in table)

A \ B	lb-in	lb-ft	oz-in	N-m	kg-cm	kg-m	gm-cm	dyne-cm
lb-in	1	8.333×10^{-2}	16	0.113	1.152	1.152×10^{-2}	1.152×10^3	1.129×10^6
lb-ft	12	1	192	1.355	13.825	0.138	1.382×10^4	1.355×10^7
oz-in	6.25×10^{-2}	5.208×10^{-3}	1	7.061×10^{-3}	7.200×10^{-2}	7.200×10^{-4}	72.007	7.061×10^4
N-m	8.850	0.737	141.612	1	10.197	0.102	1.019×10^4	1×10^7
kg-cm	0.8679	7.233×10^{-2}	13.877	9.806×10^{-2}	1	10^{-2}	1000	9.806×10^5
kg-m	86.796	7.233	1.388×10^3	9.806	100	1	1×10^5	9.806×10^7
gm-cm	8.679×10^{-4}	7.233×10^{-5}	1.388×10^{-2}	9.806×10^{-5}	1×10^{-3}	1×10^{-5}	1	980.665
dyne-cm	8.850×10^{-7}	7.375×10^{-8}	1.416×10^{-5}	10^{-7}	1.0197×10^{-6}	1.019×10^{-8}	1.019×10^{-3}	1

Length (to convert from A to B, multiply by entry in table)

A \ B	inches	feet	cm	yd	mm	m
inches	1	0.0833	2.54	0.028	25.4	0.0254
feet	12	1	30.48	0.333	304.8	0.3048
cm	0.3937	0.03281	1	1.09×10^{-2}	10	0.01
yd	36	3	91.44	1	914.4	0.914
mm	0.03937	0.00328	0.1	1.09×10^{-3}	1	0.001
m	39.37	3.281	100	1.09	1000	1

Force (to convert from A to B, multiply by entry in table)

A \ B	lb	oz	gm	dyne	N
lb	1	16	453.6	4.448×10^5	4.4482
oz	0.0625	1	28.35	2.780×10^4	0.27801
gm	2.205×10^{-3}	0.03527	1	1.02×10^{-3}	N.A.
dyne	2.248×10^{-6}	3.59×10^{-5}	980.7	1	0.00001
N	0.22481	3.5967	N.A.	100000	1

Mass (to convert from A to B, multiply by entry in table)

A \ B	lb	oz	gm	kg	slug
lb	1	16	453.6	0.4536	0.0311
oz	6.25×10^{-2}	1	28.35	0.02835	1.93×10^{-3}
gm	2.205×10^{-3}	3.527×10^{-2}	1	10^{-3}	6.852×10^{-5}
kg	2.205	35.27	10^3	1	6.852×10^{-2}
slug	32.17	514.8	1.459×10^4	14.59	1

Rotation (to convert from A to B, multiply by entry in table)

A \ B	rpm	rad/s	degrees/s
rpm	1	0.105	6.0
rad/s	9.55	1	57.30
degrees/s	0.167	1.745×10^{-2}	1

Power (to convert from A to B, multiply by entry in table)

A \ B	hp	Watts
hp (English)	1	745.7
(lb-in) (deg./s)	2.645×10^{-6}	1.972×10^{-3}
(lb-in) (rpm)	1.587×10^{-5}	1.183×10^{-2}
(lb-ft) (deg./s)	3.173×10^{-5}	2.366×10^{-2}
(lb-ft) (rpm)	1.904×10^{-4}	0.1420
Watts	1.341×10^{-3}	1

Conversion tables

Temperature Conversion

°F	°C	°C	°F
0	-17.8	-10	14
32	0	0	32
50	10	10	50
70	21.1	20	68
90	32.2	30	86
98.4	37	37	98.4
212	100	100	212
subtract 32 and multiply by $\frac{5}{9}$		multiply by $\frac{9}{5}$ and add 32	

Mechanism Efficiencies

Acme-screw with brass nut	~0.35–0.65
Acme-screw with plastic nut	~0.50–0.85
Ball-screw	~0.85–0.95
Chain and sprocket	~0.95–0.98
Preloaded ball-screw	~0.75–0.85
Spur or bevel-gears	~0.90
Timing belts	~0.96–0.98
Worm gears	~0.45–0.85
Helical gear (1 reduction)	~0.92

Friction Coefficients

Materials	μ
Steel on steel (greased)	~0.15
Plastic on steel	~0.15–0.25
Copper on steel	~0.30
Brass on steel	~0.35
Aluminum on steel	~0.45
Steel on steel	~0.58
Mechanism	μ
Ball bushings	<0.001
Linear bearings	<0.001
Dove-tail slides	~0.2++
Gibb ways	~0.5++

Material Densities

Material	lb-in ³	gm-cm ³
Aluminum	0.096	2.66
Brass	0.299	8.30
Bronze	0.295	8.17
Copper	0.322	8.91
Hard wood	0.029	0.80
Soft wood	0.018	0.48
Plastic	0.040	1.11
Glass	0.079–0.090	2.2–2.5
Titanium	0.163	4.51
Paper	0.025–0.043	0.7–1.2
Polyvinyl chloride	0.047–0.050	1.3–1.4
Rubber	0.033–0.036	0.92–0.99
Silicone rubber, without filler	0.043	1.2
Cast iron, gray	0.274	7.6
Steel	0.280	7.75

Wire Gauges¹⁾

Cross-section mm ²	Standard Wire Gauge (SWG)	American Wire Gauge (AWG)
0.2	25	24
0.3	23	22
0.5	21	20
0.75	20	19
1.0	19	18
1.5	17	16
2.5	15	13
4	13	11
6	12	9
10	9	7
16	7	6
25	5	3
35	3	2
50	0	1/0
70	000	2/0
95	00000	3/0
120	0000000	4/0
150	–	6/0
185	–	7/0

¹⁾ The table shows approximate SWG/AWG sizes nearest to standard metric sizes; the cross-sections do not match exactly.

Appendix

Metal surcharges

Explanation of the raw material/metal surcharges¹⁾

Surcharge calculation

To compensate for variations in the price of the raw materials silver, copper, aluminum, lead, gold, dysprosium²⁾ and/or neodym²⁾, surcharges are calculated on a daily basis using the so-called metal factor. These apply to products containing these raw materials and are calculated per raw material. These surcharges are added to the price of a product if the basic official price (BOP) of the raw material in question is exceeded. Surcharges are calculated in accordance with the following criteria:

Basic official price (BOP) of the raw material

- BOP of the workday prior to receipt of the order or prior to release order (Daily Price) for:
 - Silver (processed)³⁾
 - Gold (processed)³⁾
 - Aluminum (temporary constant 360.31 EUR per 100 kg, due to loss of DEL-Notiz)
 - Lead (constant 199.50 EUR per 100 kg)
- BOP of two workdays prior to receipt of the order or prior to release order (Daily Price) per 100 kg for:
 - Copper (LME-notation/10, converted from USD to EUR using LME-FX-Rate [MTLE] + 1.2%) + 1%⁴⁾
- If BOP is suspended, the last one is used.

Metal factor of the products

Certain products are displayed with a metal factor. The metal factor determines the official price (for those raw materials concerned) as of which the metal surcharges are applied and the calculation method used (weight or percentage method). An exact explanation is given below.

Structure of the metal factor

Metal factor consists of several digits; the first digit indicates whether the percentage method of calculation refers to the list price or a discounted price (customer net price) (L = list price / N = customer net price).

The remaining digits indicate the method of calculation used for the respective raw material. If no surcharge is added for a raw material, a "-" is used.

1st digit	List or customer net price using the percentage method
2nd digit	for silver (AG)
3rd digit	for copper (CU)
4th digit	for aluminum (AL)
5th digit	for lead (PB)
6th digit	for gold (AU)
7th digit	for dysprosium (Dy) ²⁾
8th digit	for neodym (Nd) ²⁾

Weight method

The weight method uses the BOP, the daily price and the raw material weight. In order to calculate the surcharge, the BOP must be subtracted from the daily price. The difference is then multiplied by the raw material weight.

The BOP can be found in the table below using the number (1 to 9) of the respective digit of the metal factor. The raw material weight can be found in the respective product descriptions.

Percentage method

Use of the percentage method is indicated by the letters A-Z at the respective digit of the metal factor.

The surcharge is increased - dependent on the deviation of the daily price compared with the BOP - using the percentage method in "steps" and consequently offers surcharges that remain constant within the framework of this "step range". A higher percentage rate is charged for each new step. The respective percentage level can be found in the table below.

Metal factor examples

LEA-----

Basis for % surcharge: List price
 Silver Basis 150 €, Step 50 €, 0.5 %
 Copper Basis 150 €, Step 50 €, 0.1 %
 No surcharge for aluminum
 No surcharge for lead
 No surcharge for gold
 No surcharge for dysprosium
 No surcharge for neodym

N-A6-----

Basis for % surcharge: Customer net price
 No surcharge for silver
 Copper Basis 150 €, Step 50 €, 0.1 %
 Aluminum acc. to weight, basic offic. price 225 €
 No surcharge for lead
 No surcharge for gold
 No surcharge for dysprosium
 No surcharge for neodym

--3-----

No basis necessary
 No surcharge for silver
 Copper acc. to weight, basic official price 150 €
 No surcharge for aluminum
 No surcharge for lead
 No surcharge for gold
 No surcharge for dysprosium
 No surcharge for neodym

1) Refer to the separate explanation on the next page regarding the raw materials dysprosium and neodym (= rare earths).

2) For a different method of calculation, refer to the separate explanation for these raw materials on the next page.

3) Source: Umicore, Hanau (www.metalsmanagement.umicore.com).

4) Source: The London Metal Exchange – an HKEX Company (<https://www.lme.com/>).

Siemens uses LME's data and trademarks within the scope of a license granted by LME, LME has no involvement and accepts no responsibility to any third party in connection with the use of data and trademarks, onward distribution of data and trademarks by third parties is not permitted.

Explanation of the raw material/metal surcharges for dysprosium and neodym (rare earths)

Surcharge calculation

To compensate for variations in the price of the raw materials silver¹⁾, copper¹⁾, aluminum¹⁾, lead¹⁾, gold¹⁾, dysprosium and/or neodym, surcharges are calculated on a daily basis using the so-called metal factor. This applies to products containing at least one of these raw materials. The surcharge for dysprosium and neodym is calculated as a supplement to the price of a product if the basic official price (BOP) of the raw material in question is exceeded.

The surcharge is calculated in accordance with the following criteria:

- Basic official price (BOP) of the raw material²⁾
Three-month basic average price (see below) in the period before the quarter in which the order was received or the release order took place (average official price) for
 - Dysprosium (Dy metal, 99 % min. FOB China; USD/kg)
 - Neodym (Nd metal, 99 % min. FOB China; USD/kg)
- Metal factor of the products
Certain products are displayed with a metal factor. The metal factor indicates (for those raw materials concerned) the BOP as of which the surcharges for dysprosium and neodym are calculated using the weight method. An exact explanation of the metal factor is given below.

Three-month average price

The prices of rare earths vary according to the foreign currency, and there is no freely accessible stock exchange listing. This makes it more difficult for all parties involved to monitor changes in price. In order to avoid continuous adjustment of the surcharges, but to still ensure fair, transparent pricing, an average price is calculated over a three-month period using the average monthly foreign exchange rate from USD to EUR (source: European Central Bank). Since not all facts are immediately available at the start of each month, a one-month buffer is allowed before the new average price applies.

Examples of calculation of the average official price:

Period for calculation of the average price:	Period during which the order/release order is effected and the average price applies:
Sep 2012 - Nov 2012	Q1 in 2013 (Jan - Mar)
Dec 2012 - Feb 2013	Q2 in 2013 (Apr - Jun)
Mar 2013 - May 2013	Q3 in 2013 (Jul - Sep)
Jun 2013 - Aug 2013	Q4 in 2013 (Oct - Dec)

Structure of the metal factor

The metal factor consists of several digits; the first digit is not relevant to the calculation of dysprosium and neodym.

The remaining digits indicate the method of calculation used for the respective raw material. If no surcharge is added for a raw material, a "-" is used.

1st digit	List or customer net price using the percentage method
2nd digit	for silver (AG) ¹⁾
3rd digit	for copper (CU) ¹⁾
4th digit	for aluminum (AL) ¹⁾
5th digit	for lead (PB) ¹⁾
6th digit	for gold (AU) ¹⁾
7th digit	for dysprosium (Dy)
8th digit	for neodym (Nd)

Weight method

The weight method uses the basic official price, the average price and the raw material weight. In order to calculate the surcharge, the BOP must be subtracted from the average price. The difference is then multiplied by the raw material weight.

The basic official price can be found in the table below using the number (1 to 9) of the respective digit of the metal factor. Your Sales contact can inform you of the raw material weight.

Metal factor examples

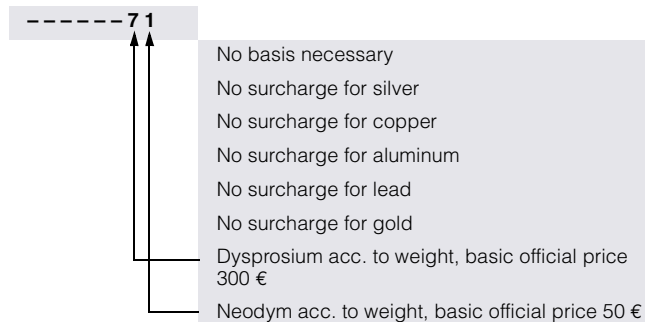

1) For a different method of calculation, refer to the separate explanation for these raw materials on the previous page.

2) Source: Asian Metal Ltd (www.asianmetal.com)

Appendix

Metal surcharges

Values of the metal factor

Percentage method	Basic official price in €	Step range in €	% surcharge 1st step	% surcharge 2nd step	% surcharge 3rd step	% surcharge 4th step	% surcharge per additional step	
			Price in €	Price in €	Price in €	Price in €		
			150.01 - 200.00	200.01 - 250.00	250.01 - 300.00	300.01 - 350.00		
A	150	50	0.1	0.2	0.3	0.4	0.1	
B	150	50	0.2	0.4	0.6	0.8	0.2	
C	150	50	0.3	0.6	0.9	1.2	0.3	
D	150	50	0.4	0.8	1.2	1.6	0.4	
E	150	50	0.5	1.0	1.5	2.0	0.5	
F	150	50	0.6	1.2	1.8	2.4	0.6	
G	150	50	1.0	2.0	3.0	4.0	1.0	
H	150	50	1.2	2.4	3.6	4.8	1.2	
I	150	50	1.6	3.2	4.8	6.4	1.6	
J	150	50	1.8	3.6	5.4	7.2	1.8	
			175.01 - 225.00	225.01 - 275.00	275.01 - 325.00	325.01 - 375.00		
O	175	50	0.1	0.2	0.3	0.4	0.1	
P	175	50	0.2	0.4	0.6	0.8	0.2	
R	175	50	0.5	1.0	1.5	2.0	0.5	
			225.01 - 275.00	275.01 - 325.00	325.01 - 375.00	375.01 - 425.00		
S	225	50	0.2	0.4	0.6	0.8	0.2	
U	225	50	1.0	2.0	3.0	4.0	1.0	
V	225	50	1.0	1.5	2.0	3.0	1.0	
W	225	50	1.2	2.5	3.5	4.5	1.0	
			150.01 - 175.00	175.01 - 200.00	200.01 - 225.00	225.01 - 250.00		
Y	150	25	0.3	0.6	0.9	1.2	0.3	
			400.01 - 425.00	425.01 - 450.00	450.01 - 475.00	475.01 - 500.00		
Z	400	25	0.1	0.2	0.3	0.4	0.1	
Price basis (1st digit)								
L	Calculation based on the list price							
N	Calculation based on the customer net price (discounted list price)							
Weight method	Basic official price in €							
1	50	Calculation based on raw material weight						
2	100							
3	150							
4	175							
5	200							
6	225							
7	300							
8	400							
9	555							
Miscellaneous								
-	No metal surcharge							

1. General Provisions

By using this catalog you can purchase products (hardware, software and services) described therein from Siemens Aktiengesellschaft subject to the following Terms and Conditions of Sale and Delivery (hereinafter referred to as "T&C"). Please note that the scope, the quality and the conditions for supplies and services, including software products, by any Siemens entity having a registered office outside Germany, shall be subject exclusively to the General Terms and Conditions of the respective Siemens entity. The following T&C apply exclusively for orders placed with Siemens Aktiengesellschaft, Germany.

1.1 For customers with a seat or registered office in European Union

For customers with a seat or registered office in European Union, the following terms and conditions apply subordinate to T&C:

- for products, which include specific terms and conditions in the description text, these specific terms and conditions shall apply and subordinate thereto,
- for stand-alone software products and software products forming a part of a product or project, the "General License Conditions for Software Products for Automation and Drives for Customers with a Seat or registered Office in Germany"¹⁾ and/or
- for consulting services the "Allgemeine Geschäftsbedingungen für Beratungsleistungen der Division DF – Deutschland" (available only in German) and/or
- for other services, the „Supplementary Terms and Conditions for Services ("BL")"¹⁾ and/or
- for other supplies the "General Conditions for the Supply of Products and Services of the Electrical and Electronics Industry"¹⁾.

In case such supplies should contain Open Source Software, the conditions of which shall prevail over the "General Conditions for the Supply of Products and Services of the Electrical and Electronics Industry"¹⁾, a notice will be contained in the scope of delivery in which the applicable conditions for Open Source Software are specified. This shall apply mutatis mutandis for notices referring to other third party software components.

1.2 For customers with a seat or registered office outside European Union

For customers with a seat or registered office outside European Union, the following terms and conditions apply subordinate to T&C:

- for products, which include specific terms and conditions in the description text, these specific terms and conditions shall apply and subordinate thereto,
- for consulting services the "Standard Terms and Conditions for Consulting Services of the Division DF for Customers with a Seat or Registered Office Outside of Germany"¹⁾ and/or
- for other services the "International Terms & Conditions for Services"¹⁾ supplemented by "Software Licensing Conditions"¹⁾ and/or
- for other supplies of hard- and software the "International Terms & Conditions for Products"¹⁾ supplemented by "Software Licensing Conditions"¹⁾

1.3 For customers with master or framework agreement

To the extent our supplies and/or services offered are covered by an existing master or framework agreement, the terms and conditions of that agreement shall apply instead of T&C.

2. Prices

The prices are in € (Euro) ex point of delivery, exclusive of packaging.

The sales tax (value added tax) is not included in the prices. It shall be charged separately at the respective rate according to the applicable statutory legal regulations.

Prices are subject to change without prior notice. We will charge the prices valid at the time of delivery.

To compensate for variations in the price of raw materials (e.g. silver, copper, aluminum, lead, gold, dysprosium and neodym), surcharges are calculated on a daily basis using the so-called metal factor for products containing these raw materials.

A surcharge for the respective raw material is calculated as a supplement to the price of a product if the basic official price of the raw material in question is exceeded.

The metal factor of a product indicates the basic official price (for those raw materials concerned) as of which the surcharges on the price of the product are applied, and with what method of calculation.

You will find a detailed explanation of the metal factor on the page headed "Metal surcharges".

To calculate the surcharge (except in the cases of dysprosium and neodym), the official price from the day prior to that on which the order was received or the release order was effected is used.

To calculate the surcharge applicable to dysprosium and neodym ("rare earths"), the corresponding three-month basic average price in the quarter prior to that in which the order was received or the release order was effected is used with a one-month buffer (details on the calculation can be found in the explanation of the metal factor).

3. Additional Terms and Conditions

The dimensions are in mm. In Germany, according to the German law on units in measuring technology, data in inches apply only to devices for export.

Illustrations are not binding.

Insofar as there are no remarks on the individual pages of this catalog – especially with regard to data, dimensions and weights given – these are subject to change without prior notice.

¹⁾ The text of the Terms and Conditions of Siemens AG can be downloaded at https://mall.industry.siemens.com/legal/ww/en/terms_of_trade_en.pdf

Appendix

Conditions of sale and delivery

4. Export Regulations

We shall not be obligated to fulfill any agreement if such fulfillment is prevented by any impediments arising out of national or international foreign trade or customs requirements or any embargoes and/or other sanctions.

Export may be subject to license. We shall indicate in the delivery details whether licenses are required under German, European and US export lists.

Our products are controlled by the U.S. Government (when labeled with "ECCN" unequal "N") and authorized for export only to the country of ultimate destination for use by the ultimate consignee or end-user(s) herein identified. They may not be resold, transferred, or otherwise disposed of, to any other country or to any person other than the authorized ultimate consignee or end-user(s), either in their original form or after being incorporated into other items, without first obtaining approval from the U.S. Government or as otherwise authorized by U.S. law and regulations. Products labeled with "AL" unequal "N" are subject to European / national export authorization.

The export indications can be viewed in advance in the description of the respective goods on the Industry Mall, our online catalog system. Only the export labels "AL" and "ECCN" indicated on order confirmations, delivery notes and invoices are authoritative.

Products without label, with label "AL:N" / "ECCN:N", or label "AL:9X9999" / "ECCN: 9X9999" may require authorization from responsible authorities depending on the final end-use, or the destination.

If you transfer goods (hardware and/or software and/or technology as well as corresponding documentation, regardless of the mode of provision) delivered by us or works and services (including all kinds of technical support) performed by us to a third party worldwide, you shall comply with all applicable national and international (re-)export control regulations. In any event of such transfer of goods, works and services you shall comply with the (re-) export control regulations of the Federal Republic of Germany, of the European Union and of the United States of America.

Prior to any transfer of goods, works and services provided by us to a third party you shall in particular check and guarantee by appropriate measures that

- there will be no infringement of an embargo imposed by the European Union, by the United States of America and/ or by the United Nations by such transfer, by brokering of contracts concerning those goods, works and services or by provision of other economic resources in connection with those goods, works and services, also considering the limitations of domestic business and prohibitions of by-passing those embargoes;
- such goods, works and services are not intended for use in connection with armaments, nuclear technology or weapons, if and to the extent such use is subject to prohibition or authorization, unless required authorization is provided;
- the regulations of all applicable Sanctioned Party Lists of the European Union and the United States of America concerning the trading with entities, persons and organizations listed therein are considered.

If required to enable authorities or us to conduct export control checks, you, upon request by us, shall promptly provide us with all information pertaining to the particular end customer, the particular destination and the particular intended use of goods, works and services provided by us, as well as any export control restrictions existing.

You acknowledge that under the EU embargo regulations against Iran, Syria and Russia respectively the sale of certain listed goods and related services is subject to authorization by the competent export control authorities of the European Union. If (i) the goods or services ordered by you are destined for Iran, Syria or Russia, and (ii) the contract for our supplies and/or services is subject to prior authorization of the competent export control authorities of the European Union, the contract between you and us shall come into force in this respect only upon granting of such authorization.

The products listed in this catalog may be subject to European/German and/or US export regulations. Any export requiring approval is therefore subject to authorization by the relevant authorities.

Errors excepted and subject to change without prior notice.

Selection and ordering at Siemens SiePortal – Ordering products and downloading catalogs

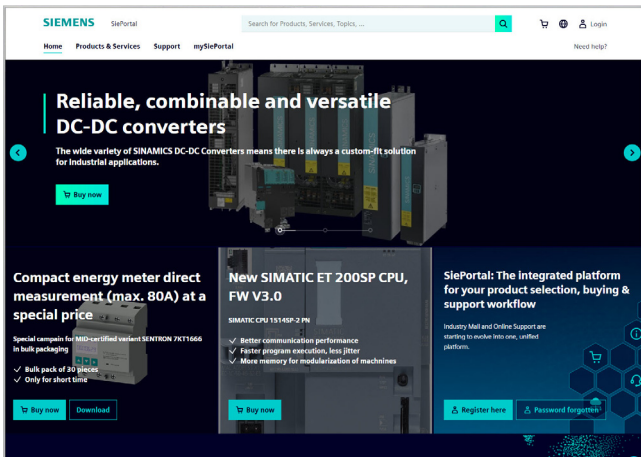

Easy product selection and ordering with SiePortal

SiePortal > Products & Services

The internet ordering platform of Siemens AG is located in SiePortal. It provides you with online access to a comprehensive product spectrum that is presented in an informative, well-organized way.

Powerful search functions help you select the required products, while configurators enable you to configure complex product and system components quickly and easily. CAX data are also available for you to use.

Data transfer allows the entire procedure, from selection through ordering to tracking and tracing, to be carried out online. Availability checks, individual customer discounting, and quotation preparation are also possible.

<https://sieportal.siemens.com>

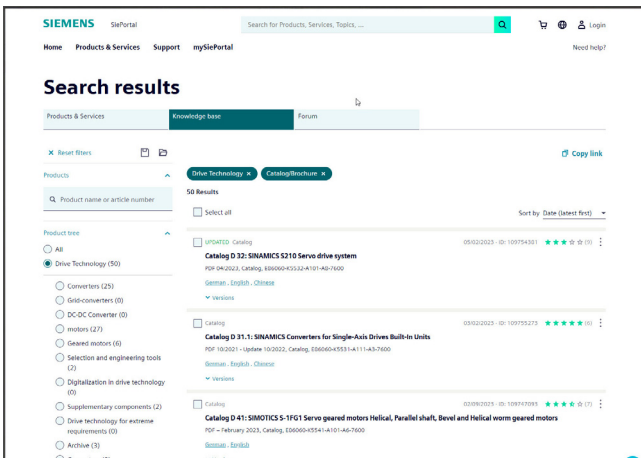

Downloading catalogs

SiePortal > Support > Knowledge base

You can download catalogs and brochures in PDF format from Siemens Industry Online Support without having to register.

The filter box makes it possible to perform targeted searches.

<https://sieportal.siemens.com>

Get more information

The SINAMICS converter family:

www.siemens.com/sinamics

SIMOTICS electric motors:

www.siemens.com/simotics

Motion Control Systems and Solutions for production machine and machine tool equipment:

www.siemens.com/motioncontrol

Local partners worldwide:

www.siemens.com/automation-contact

Published by
Siemens AG

Digital Industries
Motion Control
Postfach 31 80
91050 Erlangen, Germany

For the U.S. published by
Siemens Industry Inc.

100 Technology Drive
Alpharetta, GA 30005
United States

PDF (Article No. E86060-K5537-A111-A1-7600)
V6.MKKATA.GMC.140
KG 0823 138 En
Produced in Germany
© Siemens 2023

Security information

Siemens provides products and solutions with industrial security functions that support the secure operation of plants, systems, machines and networks.

In order to protect plants, systems, machines and networks against cyber threats, it is necessary to implement – and continuously maintain – a holistic, state-of-the-art industrial security concept.

Siemens' products and solutions constitute one element of such a concept.

Customers are responsible for preventing unauthorized access to their plants, systems, machines and networks. Such systems, machines and components should only be connected to an enterprise network or the internet if and to the extent such a connection is necessary and only when appropriate security measures (e.g. firewalls and/or network segmentation) are in place.

For additional information on industrial security measures that may be implemented, please visit <https://www.siemens.com/industrialsecurity>

Siemens' products and solutions undergo continuous development to make them more secure. Siemens strongly recommends that product updates are applied as soon as they are available and that the latest product versions are used. Use of product versions that are no longer supported, and failure to apply the latest updates may increase customer's exposure to cyber threats.

To stay informed about product updates, subscribe to the Siemens Industrial Security RSS Feed under <https://www.siemens.com/cert>

Subject to changes and errors. The information given in this document only contains general descriptions and/or performance features which may not always specifically reflect those described, or which may undergo modification in the course of further development of the products. The requested performance features are binding only when they are expressly agreed upon in the concluded contract.

All product designations may be trademarks or product names of Siemens AG or other companies whose use by third parties for their own purposes could violate the rights of the owners.