

Contents

Selection	15-2
Full Voltage Non-Reversing	
NEMA 4X Non-Metallic	15-4
Full Voltage Metallic	15-8
Non - Combination	15-9
Circuit Breaker Combination	15-10
Fusible Switch Combination and Non-Fusible Starter	15-11
Full Voltage Reversing	
General	15-12
Non - Combination	15-13
Circuit Breaker Combination	15-14
Fusible Switch Combination and Non-Fusible Starter	15-15
Two Speed Starters	
General	15-16
Two Windings, Constant or Variable Torque	
Non - Combination	15-17
Circuit Breaker Combination	15-18
Fusible Switch Combination and Non-Fusible Starter	15-19
Single Winding, Constant or Variable Torque	
Non - Combination	15-20
Circuit Breaker Combination	15-21
Fusible Switch Combination and Non-Fusible Starter	15-22
Overload Relay Chart	15-23
Factory Modifications	
Selection	15-24
SIRIUS Pre - Assembled Starter Packages	15-29
Dimensions	15-32



Siemens SIRIUS IEC Starters

The SIRIUS IEC Starter is the new generation of IEC HP rated magnetic starters, designed to meet and exceed today's market requirements for HP rated starters.

The new SIRIUS Starters take advantage of the reliability of the SIRIUS line of contactors and overload relays in addition to the new line of SIGNUM 3SB3 22mm pilot devices as the standard control device.

As evident in the design and size, all efforts were put in place to offer a new line of starters that exceeds the performance of the previous generation.

① 1NO auxiliary contact for starters up to 10HP at 600V.



The SIRIUS IEC Starters line also offers more price flexibility in the very competitive starters market.

SIRIUS Starters Features:

- CSA approved
- 100HP, 600V max
- Standard 2NO+2NC auxiliary contacts^①
- Ambient 60°C on contactors
- Fast and simple 3-prong overload contactor connection: no coil extension required
- Standard primary and secondary fusing on control transformers
- Standard Metal 22mm SIGNUM Control Devices

SIRIUS HP Rated Magnetic Starters

Selection

Catalogue Number Selection Guide						
Starter Series	Disconnect Type	Starter Type	Enclosure Type	Contactor Ref. Number	Coil Voltage	Overload Relay Setting Range
page 15-3-15-18						page 15-19
V SIRIUS IEC HP rated Starter	1 Non-combination	A FVNR	B CSA type 1 EEMAC type 1 general purpose	15 3RT1015	C 24V/60Hz 24V/50Hz	OA to 4M Standard Class 10 bimetal overload relay RB Optional Class 20 electronic overload relay 00 Provision for field mounting of overload relay
	2 Circuit breaker combination	B FVR	C CSA type 5 EEMAC type 12 dust tight industrial use	16 3RT1016	K 120V/60 Hz 110V/50Hz	
	3 Non-fusible type	N 2S1W constant or variable torque	D CSA type 4 EEMAC type 4 watertight	17 3RT1017	M 208V/60Hz	
	4 Fusible combination	R 2S1W constant horsepower	F CSA type 4x EEMAC type 4x watertight corrosion resistant	25 3RT1025	P 240V/60Hz 220V/50Hz	
		U 2S2W constant horsepower		26 3RT1026	V 460V/60Hz 380V/50Hz	
		W 2S2W constant or variable torque		33 3RT1033	T 600V/60Hz	
				34 3RT1034	Z Others Specify	
				35 3RT1035		
				36 3RT1036		
				44 3RT1044		
			45 3RT1045			
			46 3RT1046			



A.C. Magnetic Starters

Selection

Catalogue Number Selection Guide							
Power Line Voltage	Control Circuit	Additional Auxiliary Contacts	Pilot Devices				
			Operators		Indicators		
			Operators Type	Legend Plate(s)	Indicator Type	Functions	Colour Choice
page 15-20	page 15-21	pages 15-21-15-22			page 15-22	page 15-23	
6 600V Max. Distributor Stock	0 Separate control circuit, unfused	0 None	0 none	0 none	0 none	0 none	0 none
1 120V/1Ph/60Hz	N Separate control circuit, fused max 250V	E 4 N.O.	1 or 2 1 push button extended head red	A EMERGENCY STOP	1 or 2 Full Voltage 120V c/w legend plate(s)	1 to 5 1 indicator for 1 function	C to F Colour choice for 1 indicator
2 208V/3PH/60Hz	F 1 N.O. + 1 N.C.	F 1 N.O. + 1 N.C.	3 or 4 1 twist lock mushroom red	B STOP	3 or 4 Full Voltage 24V c/w legend plate(s)	6 to 8 and A to E 2 indicators for 2 functions	1 to 6 Colour choice for 2 indicators
3 230V/3PH/60Hz	P One control fuse for 120V 1 ph.	J 3 N.O. + 1 N.C.	5 or 6 2 push buttons 1-red, 1-green	C START STOP	5 or 6 Full Voltage 120V LED c/w legend plate(s)	F to R 3 indicators for 3 functions	K to P Colour choice for 3 indicators
4 460V/3Ph/60Hz	R Standard control transformer c/w 2 prim. & 1 sec. 120V fuse	K 2 N.C.	7 or 8 3 push buttons 1-red, 2-black	D ON OFF	7 or 8 Full Voltage 24V LED c/w legend plate(s)	9 Other Specify each colour per function	9 Other Specify each colour per function
5 575V/3Ph/60Hz	U Extra 50VA capacity Control Transformer	L 2 N.O.	A or B 2 pos. selector switch	E to J 3 legend plates for 3 push button	9 Other Specify		
7 230V/1Ph/60Hz	W Extra 100VA capacity Control Transformer	M 2 N.O. + 2 N.C.	C or D 2 pos. selector switch spring return	K to T 1 legend plate for 2 pos. selector switch			
8 208V/3Ph/60Hz with 4 wires (+Neutral)		9 Other Specify	E or F 2 pos. selector switch key operated	1 to 8 1 legend plate for 3 pos. selector switch	A Full Voltage 120V w/o legend plate(s)		
9 Other Specify			G or H 3 pos. selector switch	X 3 legend plates for 3 pos. selector switch and START STOP push button	B Full Voltage 24V w/o legend plate(s)		
			J or K 3 pos. selector switch spring return	9 Other Specify	C Full Voltage 120V LED w/o legend plate(s)		
			L or M 3 pos. selector switch key operated		D Full Voltage 24V LED w/o legend plate(s)		
			N or P 3 pos. selector switch spring return key operated		9 Other Specify		
			T or U 3 pos. selector switch and 2 push buttons START STOP for hand operation				
			9 Other Specify				

15
LOW VOLTAGE
MOTOR STARTERS

Full Voltage Non-Reversing

NEMA 4X Non-Metallic

Selection

Non-Combination - Up to 10HP - 600V

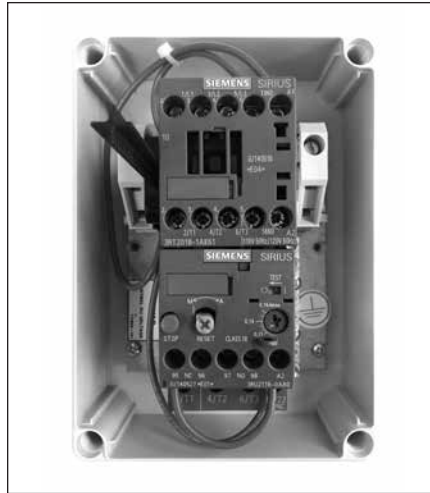

Features

- High quality and reliability
- Up to 10HP at 600V rating
- 1 NO auxiliary contact
- Class 10 bimetal overload relays including:
 - Manual reset
 - Phase Loss Protection
 - Separate Trip or Alarm contact
- NEMA 4X polycarbonate enclosure with conduit entry knockouts
- Offered in 120V AC separate control
- Wiring kit for single phase conversion included

LOW VOLTAGE
MOTOR STARTERS
15

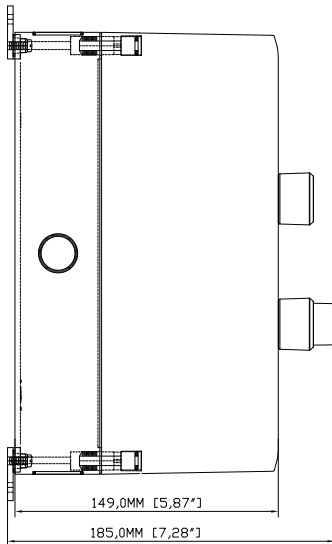

SIDE VIEW OF ENCLOSURE

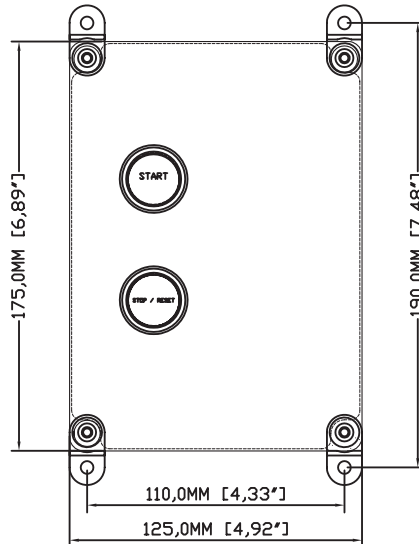

TOP OF ENCLOSURE

Enclosed Amps	CSA Maximum HP Rating						Pilot Devices	Coil Voltage	Contactor Reference Number	Aux. Contacts supplied as standard per contactor		Enclosure Plastic CSA type 4X Order No.
	1 phase		3-phase							NO	NC	
11	0.5	1.5	3	3	7.5	10	Mechanical Start/Stop Pushbutton	17	1	0	3RE3110-00A17-1AB0	
11	0.5	1.5	3	3	7.5	10					3RE3110-00A17-1AK6	
11	0.5	1.5	3	3	7.5	10					3RE3110-00A17-1AP6	

Full Voltage Non-Reversing

Overload Range and Short Circuit Ratings

Selection

HP	Power Line Voltage	FLC*	Contactors	"Bimetallic O/L (Class 10)"	O/L Range	"WHEN PROTECTED BY OVER CURRENT PROTECTION" Fuse type CC, RK1, RK5, K5, J	"KAIC Rating"
1/10	120V/1PH	3	3RT2017/18	3RU2116-1EB0	2.8 - 4.0 A	15	5 Kaic
1/8	120V/1PH	3.8	3RT2017/18	3RU2116-1FB0	3.5 - 5.0 A	20	5 Kaic
1/6	120V/1PH	4.4	3RT2017/18	3RU2116-1FB0	3.5 - 5.0 A	20	5 Kaic
1/4	120V/1PH	5.8	3RT2017/18	3RU2116-1GB0	4.5 - 6.3 A	25	5 Kaic
1/3	120V/1PH	7.2	3RT2017/18	3RU2116-1HB0	5.5 - 8.0 A	30	5 Kaic
1/2	120V/1PH	9.8	3RT2017/18	3RU2116-1KB0	9.0 - 12.5 A	45 / 50 J	5 Kaic
1/4	208V/3PH	1.1	3RT2017/18	3RU2116-0KB0	0.9 - 1.25 A	3	1 Kaic
1/3	208V/3PH	1.33	3RT2017/18	3RU2116-1AB0	1.1 - 1.6 A	6	1 Kaic
1/2	208V/3PH	2.42	3RT2017/18	3RU2116-1CB0	1.8 - 2.5 A	10	5 Kaic
3/4	208V/3PH	3.52	3RT2017/18	3RU2116-1EB0	2.8 - 4.0 A	15	5 Kaic
1	208V/3PH	4.62	3RT2017/18	3RU2116-1GB0	4.5 - 6.3 A	25	5 Kaic
1 1/2	208V/3PH	6.6	3RT2017/18	3RU2116-1HB0	5.5 - 8.0 A	30	5 Kaic
2	208V/3PH	7.48	3RT2017/18	3RU2116-1JB0	7.0 - 10 A	40	5 Kaic
3	208V/3PH	10.56	3RT2017/18	3RU2116-1KB0	9.0 - 12.5 A	45 / 50 J	5 Kaic
1/10	240V/1PH	1.5	3RT2017/18	3RU2116-1AB0	1.1 - 1.6 A	6	1 Kaic
1/8	240V/1PH	1.9	3RT2017/18	3RU2116-1CB0	1.8 - 2.5 A	10	5 Kaic
1/6	240V/1PH	2.2	3RT2017/18	3RU2116-1CB0	1.8 - 2.5 A	10	5 Kaic
1/4	240V/1PH	2.9	3RT2017/18	3RU2116-1DB0	2.2 - 3.2 A	10	5 Kaic
1/3	240V/1PH	3.6	3RT2017/18	3RU2116-1EB0	2.8 - 4.0 A	15	5 Kaic
1/2	240V/1PH	4.9	3RT2017/18	3RU2116-1GB0	4.5 - 6.3 A	25	5 Kaic
3/4	240V/1PH	6.9	3RT2017/18	3RU2116-1HB0	5.5 - 8.0 A	30	5 Kaic
1	240V/1PH	8	3RT2017/18	3RU2116-1JB0	7.0 - 10 A	40	5 Kaic
1 1/2	240V/1PH	10	3RT2017/18	3RU2116-1KB0	9.0 - 12.5 A	45 / 50 J	5 Kaic
1/4	240V/3PH	0.96	3RT2017/18	3RU2116-0KB0	0.9 - 1.25 A	3	1 Kaic
1/3	240V/3PH	1.16	3RT2017/18	3RU2116-1AB0	1.1 - 1.6 A	6	1 Kaic
1/2	240V/3PH	2.2	3RT2017/18	3RU2116-1CB0	1.8 - 2.5 A	10	5 Kaic
3/4	240V/3PH	3.2	3RT2017/18	3RU2116-1EB0	2.8 - 4.0 A	15	5 Kaic
1	240V/3PH	4.2	3RT2017/18	3RU2116-1FB0	3.5 - 5.0 A	20	5 Kaic
1 1/2	240V/3PH	6	3RT2017/18	3RU2116-1HB0	5.5 - 8.0 A	30	5 Kaic
2	240V/3PH	6.8	3RT2017/18	3RU2116-1HB0	5.5 - 8.0 A	30	5 Kaic
3	240V/3PH	9.6	3RT2017/18	3RU2116-1KB0	9.0 - 12.5 A	45 / 50 J	5 Kaic
1/4	480V/3PH	0.48	3RT2017/18	3RU2116-0GB0	0.45 - 0.63 A	3	1 Kaic
1/3	480V/3PH	0.58	3RT2017/18	3RU2116-0HB0	0.55 - 0.8 A	3	1 Kaic
1/2	480V/3PH	1	3RT2017/18	3RU2116-0JB0	0.7 - 1.0 A	3	1 Kaic
3/4	480V/3PH	1.4	3RT2017/18	3RU2116-1AB0	1.1 - 1.6 A	6	1 Kaic
1	480V/3PH	1.8	3RT2017/18	3RU2116-1CB0	1.8 - 2.5 A	10	5 Kaic
1 1/2	480V/3PH	2.6	3RT2017/18	3RU2116-1DB0	2.2 - 3.2 A	10	5 Kaic
2	480V/3PH	3.4	3RT2017/18	3RU2116-1EB0	2.8 - 4.0 A	15	5 Kaic
3	480V/3PH	4.8	3RT2017/18	3RU2116-1FB0	3.5 - 5.0 A	20	5 Kaic
5	480V/3PH	7.6	3RT2017/18	3RU2116-1JB0	7.0 - 10 A	40	5 Kaic
7 1/2	480V/3PH	11	3RT2017/18	3RU2116-1KB0	9.0 - 12.5 A	45 / 50 J	5 Kaic
1/4	600V/3PH	0.38	3RT2017/18	3RU2116-0FB0	0.35 - 0.5 A	1	1 Kaic
1/3	600V/3PH	0.47	3RT2017/18	3RU2116-0GB0	0.45 - 0.63 A	3	1 Kaic
1/2	600V/3PH	0.9	3RT2017/18	3RU2116-0JB0	0.7 - 1.0 A	3	1 Kaic
3/4	600V/3PH	1.3	3RT2017/18	3RU2116-1AB0	1.1 - 1.6 A	6	1 Kaic
1	600V/3PH	1.7	3RT2017/18	3RU2116-1BB0	1.4 - 2.0 A	6	5 Kaic
1 1/2	600V/3PH	2.4	3RT2017/18	3RU2116-1CB0	1.8 - 2.5 A	10	5 Kaic
2	600V/3PH	2.7	3RT2017/18	3RU2116-1DB0	2.2 - 3.2 A	10	5 Kaic
3	600V/3PH	3.9	3RT2017/18	3RU2116-1EB0	2.8 - 4.0 A	15	5 Kaic
5	600V/3PH	6.1	3RT2017/18	3RU2116-1HB0	5.5 - 8.0 A	30	5 Kaic
7 1/2	600V/3PH	9	3RT2017/18	3RU2116-1JB0	7.0 - 10 A	40	5 Kaic
10	600V/3PH	11	3RT2017/18	3RU2116-1KB0	9.0 - 12.5 A	45 / 50 J	5 Kaic

15
LOW VOLTAGE
MOTOR STARTERS

Note:

FLC: as per CSA 22.2 No.14-13 table 18A.

For all the 3RU2116 Overloads, the contactor can be use are 3RT2017, 3RT2018, 11 Amps max. in the enclosure

Full Voltage Non-Reversing

NEMA 4X Non-Metallic

Selection

Non-Combination - Up to 10HP - 600V



Features

- High quality and reliability
- Up to 20HP at 600V rating
- 1 NO + 1NC auxiliary contact
- Class 10 bimetal overload relays including:
 - Manual reset
 - Phase Loss Protection
 - Separate Trip and/or Alarm contact
- NEMA 4X polycarbonate enclosure with conduit entry knockouts
- Offered in 120V AC separate control
- Wiring kit for single phase conversion included

LOW VOLTAGE
MOTOR STARTERS 15

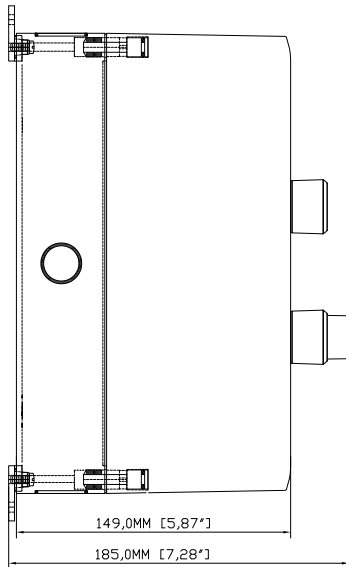

SIDE VIEW OF ENCLOSURE

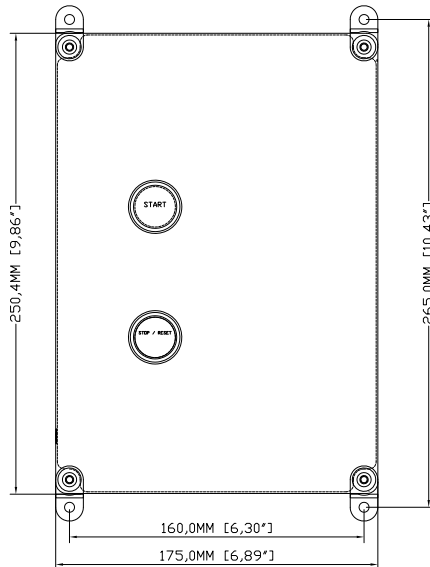

TOP OF ENCLOSURE

Enclosed Amps	CSA Maximum HP Rating						Pilot Devices	Coil Voltage	Contactor Reference Number	Aux. Contacts supplied as standard per contactor		Enclosure Plastic CSA type 4X Order No.	
	1 phase		3-phase							NO	NC		
	120V	240V	208V	240V	480V	600V							
22	1.5	3	5	7.5	15	20	Mechanical Start/Stop Pushbutton	24V ^①	27	1	1	3RE3120-00A27-0AB0	
22	1.5	3	5	7.5	15	20						120V	3RE3120-00A27-0AK6
22	1.5	3	5	7.5	15	20						240V ^①	3RE3120-00A27-0AP6

Full Voltage Non-Reversing

Overload Range and Short Circuit Ratings

Selection

HP	Power Line Voltage / Phase	FLC*	Contactora	Bimetallic O/L	O/L Range / Amp	"WHEN PROTECTED BY OVER CURRENT PROTECTION Fuse Type"	KAIC Rating
(Class / Classe 10)							
						CC, RK1, RK5, K5, J	
1/10	120V/1PH (Monophase)	3	3RT2027/28	3RU2126-1EB0	2.8 - 4.0 A	15	5 Kaic
1/8	120V/1PH (Monophase)	3.8	3RT2027/28	3RU2126-1FB0	3.5 - 5.0 A	20	5 Kaic
1/6	120V/1PH (Monophase)	4.4	3RT2027/28	3RU2126-1FB0	3.5 - 5.0 A	20	5 Kaic
1/4	120V/1PH (Monophase)	5.8	3RT2027/28	3RU2126-1GB0	4.5 - 6.3 A	25	5 Kaic
1/3	120V/1PH (Monophase)	7.2	3RT2027/28	3RU2126-1HB0	5.5 - 8.0 A	30	5 Kaic
1/2	120V/1PH (Monophase)	9.8	3RT2027/28	3RU2126-1KB0	9.0 - 12.5 A	45 / 50J	5 Kaic
3/4	120V/1PH (Monophase)	13.8	3RT2027/28	3RU2126-4AB0	11 - 16 A	60	5 Kaic
1	120V/1PH (Monophase)	16	3RT2027/28	3RU2126-4BB0	14 - 20 A	60	5 Kaic
1 1/2	120V/1PH (Monophase)	20	3RT2027/28	3RU2126-4CB0	17 - 22 A	80	5 Kaic
1/2	208V/3PH (Triphase)	2.42	3RT2027/28	3RU2126-1CB0	1.8 - 2.5 A	10	5 Kaic
3/4	208V/3PH (Triphase)	3.52	3RT2027/28	3RU2126-1EB0	2.8 - 4.0 A	15	5 Kaic
1	208V/3PH (Triphase)	4.62	3RT2027/28	3RU2126-1GB0	4.5 - 6.3 A	25	5 Kaic
1 1/2	208V/3PH (Triphase)	6.6	3RT2027/28	3RU2126-1HB0	5.5 - 8.0 A	30	5 Kaic
2	208V/3PH (Triphase)	7.48	3RT2027/28	3RU2126-1JB0	7.0 - 10 A	40	5 Kaic
3	208V/3PH (Triphase)	10.56	3RT2027/28	3RU2126-1KB0	9.0 - 12.5 A	45 / 50J	5 Kaic
5	208V/3PH (Triphase)	16.72	3RT2027/28	3RU2126-4BB0	14 - 20 A	80	5 Kaic
1/8	240V/1PH (Monophase)	1.9	3RT2027/28	3RU2126-1CB0	1.8 - 2.5 A	10	5 Kaic
1/6	240V/1PH (Monophase)	2.2	3RT2027/28	3RU2126-1CB0	1.8 - 2.5 A	10	5 Kaic
1/4	240V/1PH (Monophase)	2.9	3RT2027/28	3RU2126-1DB0	2.2 - 3.2 A	10	5 Kaic
1/3	240V/1PH (Monophase)	3.6	3RT2027/28	3RU2126-1EB0	2.8 - 4.0 A	15	5 Kaic
1/2	240V/1PH (Monophase)	4.9	3RT2027/28	3RU2126-1GB0	4.5 - 6.3 A	25	5 Kaic
3/4	240V/1PH (Monophase)	6.9	3RT2027/28	3RU2126-1HB0	5.5 - 8.0 A	30	5 Kaic
1	240V/1PH (Monophase)	8	3RT2027/28	3RU2126-1JB0	7.0 - 10 A	40	5 Kaic
1 1/2	240V/1PH (Monophase)	10	3RT2027/28	3RU2126-1KB0	9.0 - 12.5 A	45 / 50J	5 Kaic
2	240V/1PH (Monophase)	12	3RT2027/28	3RU2126-1KB0	9.0 - 12.5 A	45 / 50J	5 Kaic
3	240V/1PH (Monophase)	17	3RT2027/28	3RU2126-4BB0	14 - 20 A	80	5 Kaic
1/2	240V/3PH (Triphase)	2.2	3RT2027/28	3RU2126-1CB0	1.8 - 2.5 A	10	5 Kaic
3/4	240V/3PH (Triphase)	3.2	3RT2027/28	3RU2126-1EB0	2.8 - 4.0 A	15	5 Kaic
1	240V/3PH (Triphase)	4.2	3RT2027/28	3RU2126-1FB0	3.5 - 5.0 A	20	5 Kaic
1 1/2	240V/3PH (Triphase)	6	3RT2027/28	3RU2126-1HB0	5.5 - 8.0 A	30	5 Kaic
2	240V/3PH (Triphase)	6.8	3RT2027/28	3RU2126-1HB0	5.5 - 8.0 A	30	5 Kaic
3	240V/3PH (Triphase)	9.6	3RT2027/28	3RU2126-1KB0	9.0 - 12.5 A	45 / 50J	5 Kaic
5	240V/3PH (Triphase)	15.2	3RT2027/28	3RU2126-4BB0	14 - 20 A	60	5 Kaic
7 1/2	240V/3PH (Triphase)	22	3RT2027/28	3RU2126-4DB0	22 - 25 A	90 / 100J	5 Kaic
1	480V/3PH (Triphase)	1.8	3RT2027/28	3RU2126-1CB0	1.8 - 2.5 A	10	5 Kaic
1 1/2	480V/3PH (Triphase)	2.6	3RT2027/28	3RU2126-1DB0	2.2 - 3.2 A	10	5 Kaic
2	480V/3PH (Triphase)	3.4	3RT2027/28	3RU2126-1EB0	2.8 - 4.0 A	15	5 Kaic
3	480V/3PH (Triphase)	4.8	3RT2027/28	3RU2126-1FB0	3.5 - 5.0 A	20	5 Kaic
5	480V/3PH (Triphase)	7.6	3RT2027/28	3RU2126-1JB0	7.0 - 10 A	40	5 Kaic
7 1/2	480V/3PH (Triphase)	11	3RT2027/28	3RU2126-1KB0	9.0 - 12.5 A	45 / 50J	5 Kaic
10	480V/3PH (Triphase)	14	3RT2027/28	3RU2126-4AB0	11 - 16 A	60	5 Kaic
15	480V/3PH (Triphase)	21	3RT2027/28	3RU2126-4CB0	17 - 22 A	80	5 Kaic
1 1/2	600V/3PH (Triphase)	2.4	3RT2027/28	3RU2126-1CB0	1.8 - 2.5 A	10	5 Kaic
2	600V/3PH (Triphase)	2.7	3RT2027/28	3RU2126-1DB0	2.2 - 3.2 A	10	5 Kaic
3	600V/3PH (Triphase)	3.9	3RT2027/28	3RU2126-1EB0	2.8 - 4.0 A	15	5 Kaic
5	600V/3PH (Triphase)	6.1	3RT2027/28	3RU2126-1HB0	5.5 - 8.0 A	30	5 Kaic
7 1/2	600V/3PH (Triphase)	9	3RT2027/28	3RU2126-1JB0	7.0 - 10 A	40	5 Kaic
10	600V/3PH (Triphase)	11	3RT2027/28	3RU2126-1KB0	9.0 - 12.5 A	45 / 50J	5 Kaic
15	600V/3PH (Triphase)	17	3RT2027/28	3RU2126-4BB0	14 - 20 A	80	5 Kaic
20	600V/3PH (Triphase)	22	3RT2027/28	3RU2126-4DB0	22 - 25 A	90 / 100J	5 Kaic

15
LOW VOLTAGE
MOTOR STARTERS

Note:

FLC: as per CSA 22.2 No.14-13 table 18A.

For all the 3RU2126 Overloads the contactor can be use are 3RT2027, 3RT2028, 22 Amps max. in the enclosure.

Full Voltage Non-Reversing

Full Voltage Metallic

Selection

General

Description

Siemens full voltage non-reversing type starters are designed for full voltage across-the line starting of single or 3-phase squirrel cage motors. They also can be used as the primary control of wound rotor motors.

Combined with short circuit protection, FVNR starters are also offered as combination starters.

- Fusible disconnect type complete with Form II, Class C fuse clips, or as an option, Form I, Class J fuse clips.
- Circuit breaker type or as Non-Fusible Controller.

FVNR starters are available up to 100HP, 600V AC, EEMAC type 1 or 12 sheet metal enclosed. They are an assembly of the proven 3RT contactors and the exclusive 3RU bimetal overload relays.

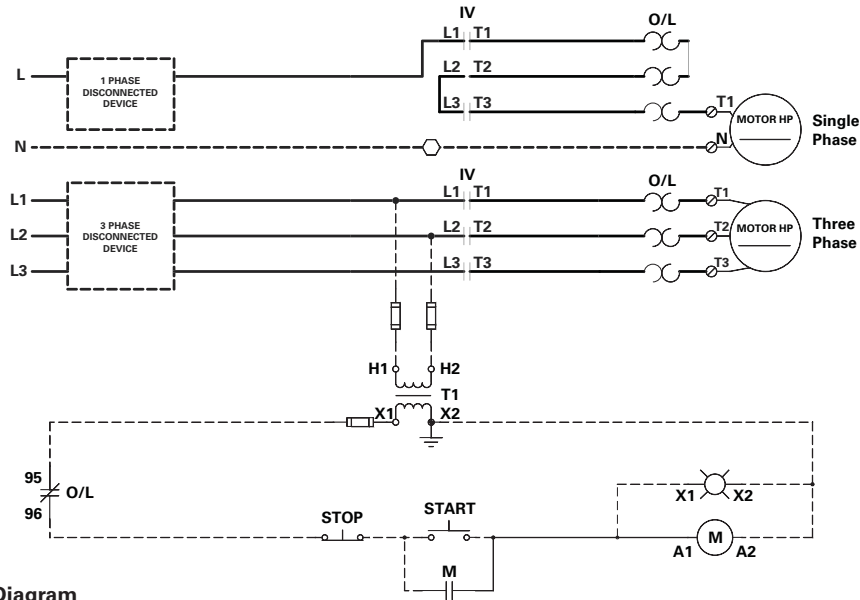

FVNR Typical Wiring Diagram

Catalogue Number:

HP Rated Starter

V 1 A B 15 K Z . .

Disconnect Type

Starter Type

Enclosure Type

Contactor Ref.

Coil Voltage

Overload Relay P. 14-19

Power Line Volt. and Control Circuit P. 14-20

Additional Aux. Contacts P. 14-21

Pilot Devices Operators P. 14-22

Pilot Devices Indicators P. 14-23

Other options P. 14-24

(fuse clips, control & timing relays, metering & protective devices, etc)

Full Voltage Non-Reversing

Non-Combination

Selection

Standard Features	Ordering Information Required	Coil Voltage Codes		
		ACV 60 Hz	ACV 50 Hz	Coil Suffix
<ul style="list-style-type: none"> 1 NO auxiliary contact on all 20A enclosed, 10 HP at 600V starters 2 NO + 2NC auxiliary contacts on all other sizes Class 10 bimetal overload relays including: <ul style="list-style-type: none"> - Manual or Automatic reset - Phase Loss Protection - Separate Trip and Alarm contact All enclosures are designed to accept a standard sized control transformer All enclosures have provisions for up to 4 pilot devices 	<ul style="list-style-type: none"> Select basic type nr. from table below. Add suffix for overload relay setting range from page 15-23 Add suffix for factory modification from page 15-24 to 15-28 	24	20	C
		120	110	K
		208	-	M
		240	220	P
		460	380	V
		600	-	T
		other voltages and frequencies are available upon request		

The type numbers in the selection table specify a 120V 60 Hz coil. If a different coil voltage is required, change the "K" (7 digit) as per Coil Suffix Table above.

Non-Combination													
Enclosed Amps	CSA MAXIMUM HP RATING						Contactor reference number	Aux, Contacts supplied as standard per contactor		Enclosure Sheet Metal			
	1 phase		3 phase					NO	NC	CSA / EEMAC Type 1 General Purpose Enclosure		CSA Type 5 / EEMAC Type 12 Industrial Use	
	115V	230V	200V	230V	460V	575V				Catalogue Number	Encl. Fig.	Catalogue Number	Encl. Fig.
20	1/4	3/4	1 ^{1/2}	2	3	5	15	1	-	V1AB15K..	V0	V1AC15K..	S
	1/3	1	2	3	5	7 ^{1/2}	16	1	-	V1AB16K..		V1AC16K..	
	1/2	2	3	3	7 ^{1/2}	10	17	1	-	V1AB17K..		V1AC17K..	
35	1	3	5	5	10	15	25	2	2	V1AB25K..	V1	V1AC25K..	S
	2	3	7 ^{1/2}	7 ^{1/2}	15	20	26	2	2	V1AB26K..		V1AC26K..	
	2	5	7 ^{1/2}	10	20	25	33	2	2	V1AB33K..		V1AC33K..	
45	2	5	10	10	25	30	34	2	2	V1AB34K..	V1	V1AC34K..	S
55	3	7 ^{1/2}	10	15	30	40	35	2	2	V1AB35K..	V1	V1AC35K..	S
	3	10	15	15	40	50	36	2	2	V1AB36K..		V1AC36K..	
90	5	15	20	25	50	60	44	2	2	V1AB44K..	V2	V1AC44K..	H2
105	7 ^{1/2}	15	25	30	60	75	45	2	2	V1AB45K..	V2	V1AC45K..	H2
	10	-	30	30	75	100	46	2	2	V1AB46K..		V1AC46K..	

15 LOW VOLTAGE MOTOR STARTERS



Full Voltage Non-Reversing

Replacement Parts

Selection

Circuit Breaker Combination

Standard Features	Ordering Information Required	Coil Voltage Codes		
		ACV 60 Hz	ACV 50 Hz	Coil Suffix
<ul style="list-style-type: none"> ▪ 1 NO auxiliary contact on all 20A enclosed, 10 HP at 600V starters ▪ 2 NO + 2NC auxiliary contacts on all other sizes ▪ Class 10 bimetal overload relays including: <ul style="list-style-type: none"> - Manual or Automatic reset - Phase Loss Protection - Separate Trip and Alarm contact ▪ All enclosures are designed to accept a standard sized control transformer ▪ All enclosures have provisions for up to 4 pilot devices 	<ul style="list-style-type: none"> ▪ Select basic type nr. from table below ▪ Add suffix for overload relay setting range from page 15-23 ▪ Add suffix for factory modification from page 15-24 to 15-28 	24	20	C
		120	110	K
		208	-	M
		240	220	P
		460	380	V
		600	-	T
		other voltages and frequencies are available upon request		

The type numbers in the selection table specify a 120V 60 Hz coil. If a different coil voltage is required, change the "K" (7 digit) as per Coil Suffix Table above.

Circuit Breaker Combination [Ⓞ]													
Enclosed Amps	CSA MAXIMUM HP RATING						Contactor reference number	Aux, Contacts supplied as standard per contactor		Enclosure Sheet Metal			
	1 phase		3 phase					NO	NC	CSA / EEMAC Type 1 General Purpose Enclosure		CSA Type 5 / EEMAC Type 12 Industrial Use	
	115V	230V	200V	230V	460V	575V				Catalogue Number	Encl. Fig.	Catalogue Number	Encl. Fig.
20	1/4	3/4	1 ^{1/2}	2	3	5	15	1	-	V2AB15K..	V2	V2AC15K..	H2
	1/3	1	2	3	5	7 ^{1/2}	16	1	-	V2AB16K..		V2AC16K..	
	1/2	2	3	3	7 ^{1/2}	10	17	1	-	V2AB17K..		V2AC17K..	
35	1	3	5	5	10	15	25	2	2	V2AB25K..	V2	V2AC25K..	H2
	2	3	7 ^{1/2}	7 ^{1/2}	15	20	26	2	2	V2AB26K..		V2AC26K..	
	2	5	7 ^{1/2}	10	20	25	33	2	2	V2AB33K..		V2AC33K..	
45	2	5	10	10	25	30	34	2	2	V2AB34K..	V2	V2AC34K..	H2
55	3	7 ^{1/2}	10	15	30	40	35	2	2	V2AB35K..	V2	V2AC35K..	H2
	3	10	15	15	40	50	36	2	2	V2AB36K..		V2AC36K..	
90	5	15	20	25	50	60	44	2	2	V2AB44K..	V4	V2AC44K..	H5
105	7 ^{1/2}	15	25	30	60	75	45	2	2	V2AB45K..	V4	V2AC45K..	H5
	10	-	30	30	75	100	46	2	2	V2AB46K..		V2AC46K..	

[Ⓞ] Factory will automatically select the circuit breaker based on standard or given motor full-load current and the following:
 - Continuous-current rating of a minimum 115% of motor full-load current.
 - Trip-setting position is 11 times motor full load current.

Full Voltage Non-Reversing

Fusible Switch Combination and Non-Fusible Starter

Selection

Standard Features	Ordering Information Required	Coil Voltage Codes		
		ACV 60 Hz	ACV 50 Hz	Coil Suffix
<ul style="list-style-type: none"> 1 NO auxiliary contact on all 20A enclosed, 10 HP at 600V starters 2 NO + 2NC auxiliary contacts on all other sizes Class 10 bimetal overload relays including: <ul style="list-style-type: none"> - Manual or Automatic reset - Phase Loss Protection - Separate Trip and Alarm contact All enclosures are designed to accept a standard sized control transformer All enclosures have provisions for up to 4 pilot devices 	<ul style="list-style-type: none"> Select basic type nr. from table below Add suffix for overload relay setting range from page 15-23 Add suffix for factory modification from page 15-24 to 15-28 	24	20	C
		120	110	K
		208	-	M
		240	220	P
		460	380	V
		600	-	T
		other voltages and frequencies are available upon request		

The type numbers in the selection table specify a 120V 60 Hz coil. If a different coil voltage is required, change the "K" (7 digit) as per Coil Suffix Table above.

Fusible Switch Combinations and Non-Fusible Starters																
Enclosed Amps	CSA MAXIMUM HP RATING						FUSE [®] CLIPS Type IIC Amps	Contactor reference number	Aux, Contacts supplied as standard per contactor		Enclosure Sheet Metal					
	1 phase		3 phase						NO		NC		CSA / EEMAC Type 1 General Purpose Enclosure		CSA Type 5 / EEMAC Type 12 Industrial Use	
	115V	230V	200V	230V	460V	575V			Catalogue Number	Encl. Fig.	Catalogue Number	Encl. Fig.				
20	1/4	3/4	1 1/2	2	3	5	NONE 30	15	1	-	V3AB15K.. V4AB15K..	V2	V3AC15K.. V4AC15K..	H2		
	1/3	1	2	3	5	7 1/2	NONE 30	16	1	-	V3AB16K.. V4AB16K..		V3AC16K.. V4AC16K..			
	1/2	2	3	3	7 1/2	10	NONE 30	17	1	-	V3AB17K.. V4AB17K..		V3AC17K.. V4AC17K..			
35	1	3	5	5	10	15	NONE 30 60	25	2	2	V3AB25K.. V4AB25K.. V4AB25K..	V2	V3AC25K.. V4AC25K.. V4AC25K..	H2		
	2	3	7 1/2	7 1/2	15	20	NONE 30 60	26	2	2	V3AB26K.. V4AB26K.. V4AB26K..		V3AC26K.. V4AC26K.. V4AC26K..			
	2	5	7 1/2	10	20	25	NONE 30 60	33	2	2	V3AB33K.. V4AB33K.. V4AB33K..		V3AC33K.. V4AC33K.. V4AC33K..			
45	2	5	10	10	25	30	NONE 30 60	34	2	2	V3AB34K.. V4AB34K.. V4AB34K..	V2	V3AC34K.. V4AC34K.. V4AC34K..	H2		
55	3	7 1/2	10	15	30	40	NONE 30 60	35	2	2	V3AB35K.. V4AB35K.. V4AB35K..	V2	V3AC35K.. V4AC35K.. V4AC35K..	H2		
	3	10	15	15	40	50	NONE 30 60 100	36	2	2	V3AB36K.. V4AB36K.. V4AB36K.. V4AB36K..		V3AC36K.. V4AC36K.. V4AC36K.. V4AC36K..			
90	5	15	20	25	50	60	NONE 30 60 100	44	2	2	V3AB44K.. V4AB44K.. V4AB44K.. V4AB44K..	V4	V3AC44K.. V4AC44K.. V4AC44K.. V4AC44K..	H5		
105	7 1/2	15	25	30	60	75	NONE 60 100 200	45	2	2	V3AB45K.. V4AB45K.. V4AB45K.. V4AB45K..	V4	V3AC45K.. V4AC45K.. V4AC45K.. V4AC45K..	H5		
	10	-	30	30	75	100	NONE 200	46	2	2	V3AB46K.. V4AB46K..		V3AC46K.. V4AC46K..			

© Starters are suitable for HRC IIC Fuses. Refer to page 15-23 for HRC IJ Fuse Clips.

Full Voltage Reversing

General

Selection

SIRIUS HP Rated Magnetic Starters

Description

Siemens full voltage reversing type starters are designed for full voltage across-the-line starting and reversing of single or 3-phase squirrel cage motors. They also can be used as the primary control of wound rotor motors.

Combined with short circuit protection, FVR starters are also offered as combination starters:

- Fusible disconnect type complete with Form II, Class C fuse clips, or as an option, Form I, Class J fuse clips.
- Circuit breaker type or as Non-Fusible Controller.

FVR - starters are available up to 100HP, 600V AC in EEMAC type 1 or 12 sheet metal enclosures.

FVR - starters are an assembly of the 3RA Reversing Contactor including electrical and mechanical interlock and a 3RU bimetallic overload relay.

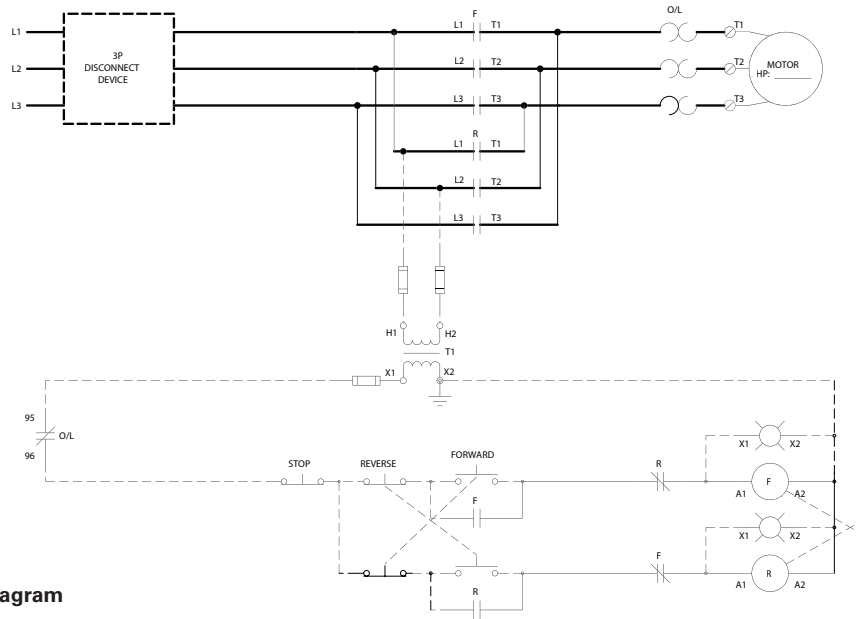

FVR Typical Wiring Diagram

Catalogue No.:

V 1 B B 15 K

HP Rated Starter

Disconnect Type

Starter Type

Enclosure Type

Contactor Ref.

Coil Voltage

Overload Relay P. 14-19

Power Line Volt. and Control Circuit P. 14-20

Additional Aux. Contacts P. 14-21

Pilot Devices Operators P. 14-22

Pilot Devices Indicators P. 14-23

Other options P. 14-24

(fuse clips, control & timing relays, metering & protective devices, etc)

Full Voltage Reversing

Non-Combination

Selection

Standard Features	Ordering Information Required	Coil Voltage Codes		
		ACV 60 Hz	ACV 50 Hz	Coil Suffix
<ul style="list-style-type: none"> ▪ Mechanical and electrical interlock ▪ 2 NO + 2 NC auxiliary contacts per contactor. For the electrical interlock, a N.C. contact is provided separately. ▪ Class 10 bimetal overload relays including: <ul style="list-style-type: none"> - Manual or Automatic reset - Phase Loss Protection - Separate Trip and Alarm contact ▪ All enclosures are designed to accept a standard sized control transformer ▪ All enclosures have provisions for up to 4 pilot devices 	<ul style="list-style-type: none"> ▪ Select basic type nr. from table below ▪ Add suffix for overload relay setting range from page 15-23 ▪ Add suffix for factory modification from page 15-24 to 15-28 	24	20	C
		120	110	K
		208	-	M
		240	220	P
		460	380	V
		600	-	T
		other voltages and frequencies are available upon request		

The type numbers in the selection table specify a 120V 60 Hz coil. If a different coil voltage is required, change the "K" (7 digit) as per Coil Suffix Table above.

Non-Combination													
Enclosed Amps	CSA MAXIMUM HP RATING						Contactor reference number	Aux, Contacts supplied as standard per contactor		Enclosure Sheet Metal			
	1 phase		3 phase					NO	NC	CSA / EEMAC Type 1 General Purpose Enclosure		CSA Type 5 / EEMAC Type 12 Industrial Use	
	115V	230V	200V	230V	460V	575V				Catalogue Number	Encl. Fig.	Catalogue Number	Encl. Fig.
20	1/4	3/4	1 ^{1/2}	2	3	5	15	2	2	V1BB15K..	V1	V1BC15K..	S
	1/3	1	2	3	5	7 ^{1/2}	16	2	2	V1BB16K..		V1BC16K..	
	1/2	2	3	3	7 ^{1/2}	10	17	2	2	V1BB17K..		V1BC17K..	
35	1	3	5	5	10	15	25	2	2	V1BB25K..	V1	V1BC25K..	S
	2	3	7 ^{1/2}	7 ^{1/2}	15	20	26	2	2	V1BB26K..	V1	V1BC26K..	S
	2	5	7 ^{1/2}	10	20	25	33	2	2	V1BB33K..	V2	V1BC33K..	H2
45	2	5	10	10	25	30	34	2	2	V1BB34K..	V2	V1BC34K..	H2
55	3	7 ^{1/2}	10	15	30	40	35	2	2	V1BB35K..	V2	V1BC35K..	H2
	3	10	15	15	40	50	36	2	2	V1BB36K..		V1BC36K..	
90	5	15	20	25	50	60	44	2	2	V1BB44K..	V3	V1BC44K..	H3
105	7 ^{1/2}	15	25	30	60	75	45	2	2	V1BB45K..	V3	V1BC45K..	H3
	10	-	30	30	75	100	46	2	2	V1BB46K..		V1BC46K..	

15
LOW VOLTAGE
MOTOR STARTERS

Full Voltage Reversing

Circuit Breaker Combination

Selection

Standard Features	Ordering Information Required	Coil Voltage Codes		
		ACV 60 Hz	ACV 50 Hz	Coil Suffix
<ul style="list-style-type: none"> ▪ Mechanical and electrical interlock ▪ 2 NO + 2 NC auxiliary contacts per contactor. For the electrical interlock, a N.C. contact is provided separately. ▪ Class 10 bimetal overload relays including: <ul style="list-style-type: none"> - Manual or Automatic reset - Phase Loss Protection - Separate Trip and Alarm contact ▪ All enclosures are designed to accept a standard sized control transformer ▪ All enclosures have provisions for up to 4 pilot devices 	<ul style="list-style-type: none"> ▪ Select basic type nr. from table below ▪ Add suffix for overload relay setting range from page 15-23 ▪ Add suffix for factory modification from page 15-24 to 15-28 	24	20	C
		120	110	K
		208	-	M
		240	220	P
		460	380	V
		600	-	T
		other voltages and frequencies are available upon request		

The type numbers in the selection table specify a 120V 60 Hz coil. If a different coil voltage is required, change the "K" (7 digit) as per Coil Suffix Table above.

Circuit Breaker Combination														
Enclosed Amps	CSA MAXIMUM HP RATING						Contactor reference number	Aux. Contacts supplied as standard per contactor		Enclosure Sheet Metal				
	1 phase		3 phase							CSA / EEMAC Type 1 General Purpose Enclosure		CSA Type 5 / EEMAC Type 12 Industrial Use		
	115V	230V	200V	230V	460V	575V				Catalogue Number	Encl. Fig.	Catalogue Number	Encl. Fig.	
20	1/4	3/4	1 1/2	2	3	5	15	2	2	V2BB15K..	V3	V2BC15K..	H3	
	1/3	1	2	3	5	7 1/2	16	2	2	V2BB16K..		V2BC16K..		
	1/2	2	3	3	7 1/2	10	17	2	2	V2BB17K..		V2BC17K..		
35	1	3	5	5	10	15	25	2	2	V2BB25K..	V3	V2BC25K..	H3	
	2	3	7 1/2	7 1/2	15	20	26	2	2	V2BB26K..		V2BC26K..		
	2	5	7 1/2	10	20	25	33	2	2	V2BB33K..		V2BC33K..		
45	2	5	10	10	25	30	34	2	2	V2BB34K..	V3	V2BC34K..	H3	
55	3	7 1/2	10	15	30	40	35	2	2	V2BB35K..	V3	V2BC35K..	H3	
	3	10	15	15	40	50	36	2	2	V2AB36K..		V2AC36K..		
90	5	15	20	25	50	60	44	2	2	V2BB44K..	V4	V2BC44K..	H5	
105	7 1/2	15	25	30	60	75	45	2	2	V2BB45K..	V4	V2BC45K..	H5	
	10	-	30	30	75	100	46	2	2	V2AB46K..		V2AC46K..		

Full Voltage Reversing

Fusible Switch Combination and Non-Fusible Starter

Selection

Standard Features	Ordering Information Required	Coil Voltage Codes		
		ACV 60 Hz	ACV 50 Hz	Coil Suffix
<ul style="list-style-type: none"> Mechanical and electrical interlock 2 NO + 2 NC auxiliary contacts per contactor. For the electrical interlock, a N.C. contact is provided separately. Class 10 bimetallic overload relays including: <ul style="list-style-type: none"> Manual or Automatic reset Phase Loss Protection Separate Trip and Alarm contact All enclosures are designed to accept a standard sized control transformer All enclosures have provisions for up to 4 pilot devices 	<ul style="list-style-type: none"> Select basic type nr. from table below Add suffix for overload relay setting range from page 15-23 Add suffix for factory modification from page 15-24 to 15-28 	24	20	C
		120	110	K
		208	-	M
		240	220	P
		460	380	V
		600	-	T
		other voltages and frequencies are available upon request		

The type numbers in the selection table specify a 120V 60 Hz coil. If a different coil voltage is required, change the "K" (7 digit) as per Coil Suffix Table above.

Fusible Switch Combinations and Non-Fusible Starters														
Enclosed Amps	CSA MAXIMUM HP RATING						FUZE CLIPS Type IIC Amps	Contactor reference number	Aux, Contacts supplied as standard per contactor		Enclosure Sheet Metal			
	1 phase		3 phase								CSA / EEMAC Type 1 General Purpose Enclosure		CSA Type 5 / EEMAC Type 12 Industrial Use	
	115V	230V	200V	230V	460V	575V			NO	NC	Catalogue Number	Encl. Fig.	Catalogue Number	Encl. Fig.
20	1/4	3/4	1 1/2	2	3	5	NONE 30	15	2	2	V3BB15K.. V4BB15K..	V3	V3BC15K.. V4BC15K..	H3
	1/3	1	2	3	5	7 1/2	NONE 30	16	2	2	V3BB16K.. V4BB16K..		V3BC16K.. V4BC16K..	
	1/2	2	3	3	7 1/2	10	NONE 30	17	2	2	V3BB17K.. V4BB17K..		V3BC17K.. V4BC17K..	
35	1	3	5	5	10	15	NONE 30 60	25	2	2	V3BB25K.. V4BB25K.. V4BB25K..	V3	V3BC25K.. V4BC25K.. V4BC25K..	H3
	2	3	7 1/2	7 1/2	15	20	NONE 30 60	26	2	2	V3BB26K.. V4BB26K.. V4BB26K..		V3BC26K.. V4BC26K.. V4BC26K..	
	2	5	7 1/2	10	20	25	NONE 30 60	33	2	2	V3BB33K.. V4BB33K.. V4BB33K..		V3BC33K.. V4BC33K.. V4BC33K..	
45	2	5	10	10	25	30	NONE 30 60	34	2	2	V3BB34K.. V4BB34K.. V4BB34K..	V3	V3BC34K.. V4BC34K.. V4BC34K..	H3
55	3	7 1/2	10	15	30	40	NONE 30 60	35	2	2	V3BB35K.. V4BB35K.. V4BB35K..	V3	V3BC35K.. V4BC35K.. V4BC35K..	H3
	3	10	15	15	40	50	NONE 30 60 100	36	2	2	V3BB36K.. V4BB36K.. V4BB36K.. V4BB36K..		V3BC36K.. V4BC36K.. V4BC36K.. V4BC36K..	
90	5	15	20	25	50	60	NONE 30 60 100	44	2	2	V3BB44K.. V4BB44K.. V4BB44K.. V4BB44K..	V4	V3BC44K.. V4BC44K.. V4BC44K.. V4BC44K..	H5
105	7 1/2	15	25	30	60	75	NONE 60 100 200	45	2	2	V3BB45K.. V4BB45K.. V4BB45K.. V4BB45K..	V4	V3BC45K.. V4BC45K.. V4BC45K.. V4BC45K..	H5
	10	-	30	30	75	100	NONE 200	46	2	2	V3BB46K.. V4BB46K..		V3BC46K.. V4BC46K..	

15
LOW VOLTAGE
MOTOR STARTERS

Two Speed Starters

General

SIRIUS HP Rated Magnetic Starters

Description

Full-voltage ac magnetic two speed controllers are designed to control reconnectable squirrel-cage induction motors for operation at two different constant speeds depending on the construction of the motor. These controllers are available in combination and non-combination types. The speed of an induction motor is a function of the supply frequency and the number of poles of the motor winding. To obtain different speeds with a fixed supply frequency, the number of magnetic poles of the motor must be changed.

Characteristics at any speed are similar to those of a single-speed motor. There are two basic methods of providing multiple-pole combinations:

Separate-Winding Motors have a separate winding for each speed. This motor construction is slightly more expensive, but the controller is relatively simple, and a wide variety of speeds can be selected. Separate winding motors with delta connected motor windings require one corner to be opened on each unused winding.

Consequent-Pole Motors have a single winding for two speeds. Extra winding taps are brought out for reconnection for different number of stator poles. While the motor costs less, the controller is more complicated, and speed range is limited to a 2-to-1 ratio.

Torque Characteristics

Multi-speed motors are divided into three application groups:

Constant Torque - HP output varies directly with speed, while torque remains constant. A constant-torque motor rated 100 HP at 1200 rpm delivers 50 HP at 600 rpm. This type is applicable to conveyors, mills, dough mixers, reciprocating pumps, and other similar loads.

Variable Torque - HP varies as a square of speed, while torque varies directly with speed. A variable-torque motor rated 100 HP at 1200 rpm delivers 25 HP at 600 rpm. This type is applicable to systems having fan or centrifugal pump characteristics.

Constant Horsepower - Motor delivers rated HP at all full-load speeds, while torque varies inversely to speed. This type is applicable to cutting tools, lathes, spindles, etc.

Selection

Selection and Ordering

Starter ratings are based on the maximum HP at the highest speed. Electrical interlocking is furnished on all multi-speed starters to preclude connecting more than one speed winding at the same time. Both mechanical and electrical interlocking is provided wherever there is a possibility of short circuiting of the line.

Standard wiring permits starting the motor on any speed. To change a running motor to a higher speed, operator presses the desired speed button. To change to a lower speed, operator must press "stop" button before selecting the lower speed; allowing time for the motor to slow down, this reduces shock on driven machinery and surges on the power system.

When control at various speeds is by means of two-wire control devices, such as limit, pressure or float switches, deceleration relays should be used, unless both the motor manufacturer and the machine manufacturer have been consulted.

Catalogue No.:

HP Rated Starter

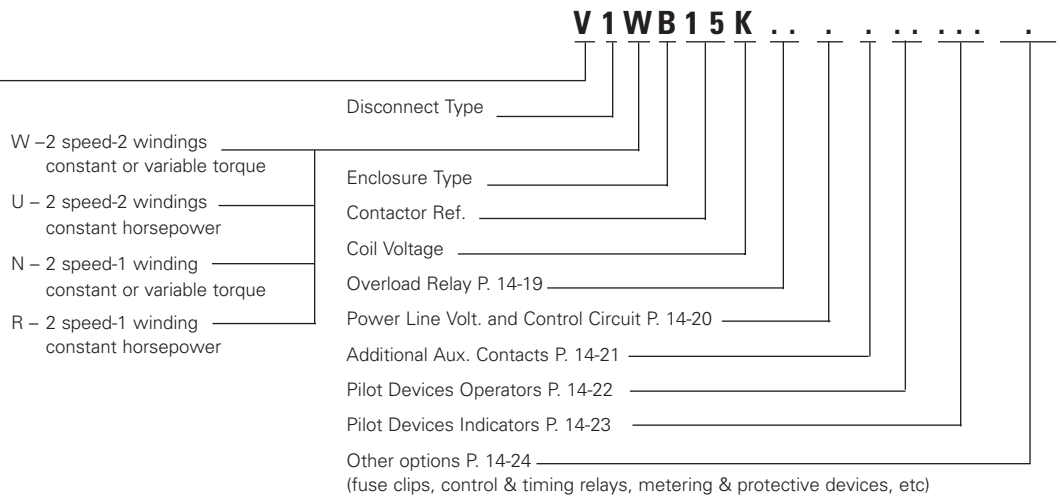

Two Speed Starters

Non-Combination

Selection

Standard Features	Ordering Information Required	Coil Voltage Codes		
		ACV 60 Hz	ACV 50 Hz	Coil Suffix
<ul style="list-style-type: none"> For auxiliary contacts provided, see Selection Table below. 1 NC auxiliary contact of each contactor is used for the electrical interlock. Class 10 bimetallic overload relays including: <ul style="list-style-type: none"> - Manual or Automatic reset - Phase Loss Protection - Separate Trip and Alarm contact All enclosures are designed to accept a standard sized control transformer All enclosures have provisions for up to 4 pilot devices 	<ul style="list-style-type: none"> Select basic type nr. from table below Add suffix for both overload relay setting range from page 15-23 Add suffix for factory modification from page 15-24 to 15-28 	24	20	C
		120	110	K
		208	-	M
		240	220	P
		460	380	V
		600	-	T
		other voltages and frequencies are available upon request		

The type numbers in the selection table below specify 120V 60 Hz coils. If a different coil voltage is required, change the "K" (7 digit) as per Coil Suffix Table above.

Non-Combination													
Enclosed Amps	CSA MAXIMUM HP RATING						Contactor reference number	Aux, Contacts supplied as standard per contactor		Enclosure Sheet Metal			
	1 phase		3 phase					NO	NC	CSA / EEMAC Type 1 General Purpose Enclosure		CSA Type 5 / EEMAC Type 12 Industrial Use	
	115V	230V	200V	230V	460V	575V				Catalogue Number	Encl. Fig.	Catalogue Number	Encl. Fig.
20	1/4	3/4	1 1/2	2	3	5	15	3	2	V1WB15K..	V2	V1WC15K..	S
	1/3	1	2	3	5	7 1/2	16	3	2	V1WB16K..		V1WC16K..	
	1/2	2	3	3	7 1/2	10	17	3	2	V1WB17K..		V1WC17K..	
35	1	3	5	5	10	15	25	2	2	V1WB25K..	V1	V1WC25K..	H2
	2	3	7 1/2	7 1/2	15	20	26	2	2	V1WB26K..	V1	V1WC26K..	H2
	2	5	7 1/2	10	20	25	33	2	2	V1WB33K..	V2	V1WC33K..	H2
45	2	5	10	10	25	30	34	2	2	V1WB34K..	V2	V1WC34K..	H2
55	3	7 1/2	10	15	30	40	35	2	2	V1WB35K..	V2	V1WC35K..	H2
	3	10	15	15	40	50	36	2	2	V1WB36K..		V1WC36K..	
90	5	15	20	25	50	60	44	2	2	V1WB44K..	V3	V1WC44K..	H3
105	7 1/2	15	25	30	60	75	45	2	2	V1WB45K..	V3	V1WC45K..	H3
	10	-	30	30	75	100	46	2	2	V1WB46K..		V1WC46K..	

15
LOW VOLTAGE
MOTOR STARTERS

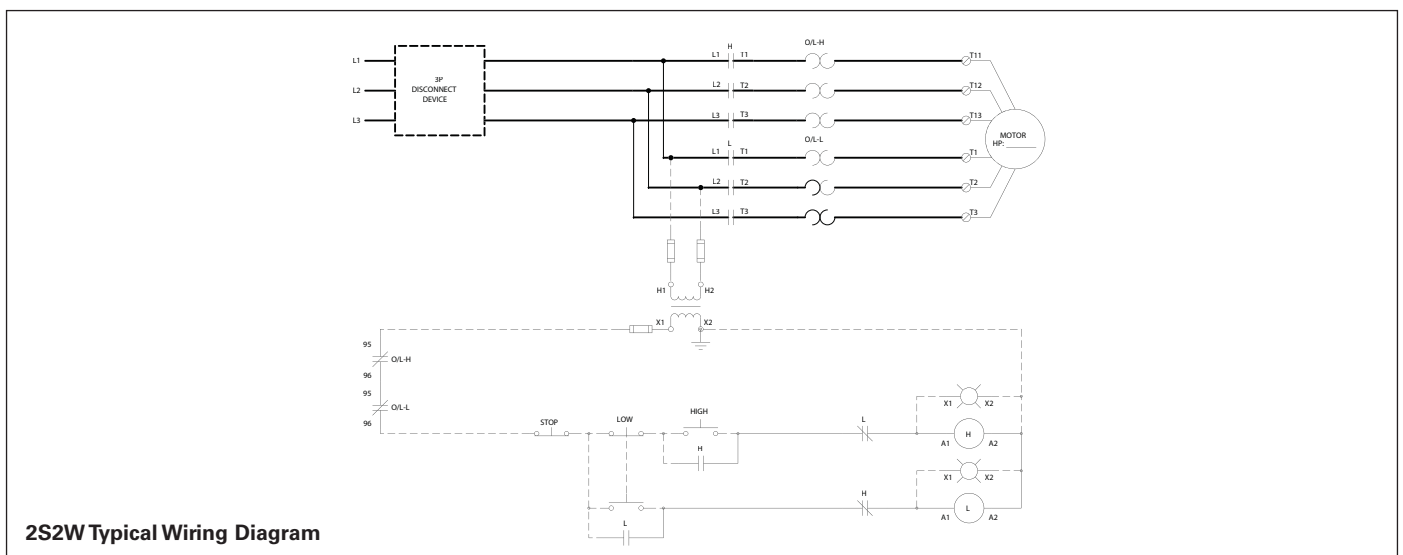

2S2W Typical Wiring Diagram

Two Speed Starters

Circuit Breaker Combination

Selection

Standard Features	Ordering Information Required	Coil Voltage Codes		
		ACV 60 Hz	ACV 50 Hz	Coil Suffix
<ul style="list-style-type: none"> For auxiliary contacts provided, see Selection Table below. 1 NC auxiliary contact of each contactor is used for the electrical interlock. Class 10 bimetallic overload relays including: <ul style="list-style-type: none"> - Manual or Automatic reset - Phase Loss Protection - Separate Trip and Alarm contact All enclosures are designed to accept a standard sized control transformer All enclosures have provisions for up to 4 pilot devices 	<ul style="list-style-type: none"> Select basic type nr. from table below Add suffix for both overload relay setting range from page 15-23 Add suffix for factory modification from page 15-24 to 15-28 	24	20	C
		120	110	K
		208	-	M
		240	220	P
		460	380	V
		600	-	T
		other voltages and frequencies are available upon request		

The type numbers in the selection table below specify 120V 60 Hz coils. If a different coil voltage is required, change the "K" (7 digit) as per Coil Suffix Table above.

Circuit Breaker Combination [Ⓞ]													
Enclosed Amps	CSA MAXIMUM HP RATING						Contactor reference number	Aux, Contacts supplied as standard per contactor		Enclosure Sheet Metal			
	1 phase		3 phase					NO	NC	CSA / EEMAC Type 1 General Purpose Enclosure		CSA Type 5 / EEMAC Type 12 Industrial Use	
	115V	230V	200V	230V	460V	575V				Catalogue Number	Encl. Fig.	Catalogue Number	Encl. Fig.
20	1/4	3/4	1 1/2	2	3	5	15	3	2	V2WB15K..	V3	V2WC15K..	H3
	1/3	1	2	3	5	7 1/2	16	3	2	V2WB16K..		V2WC16K..	
	1/2	2	3	3	7 1/2	10	17	3	2	V2WB17K..		V2WC17K..	
35	1	3	5	5	10	15	25	2	2	V2WB25K..	V3	V2WC25K..	H3
	2	3	7 1/2	7 1/2	15	20	26	2	2	V2WB26K..		V2WC26K..	
	2	5	7 1/2	10	20	25	33	2	2	V2WB33K..		V2WC33K..	
45	2	5	10	10	25	30	34	2	2	V2WB34K..	V3	V2WC34K..	H3
55	3	7 1/2	10	15	30	40	35	2	2	V2WB35K..	V3	V2WC35K..	H3
	3	10	15	15	40	50	36	2	2	V2WB36K..		V2WC36K..	
90	5	15	20	25	50	60	44	2	2	V2WB44K..	V4	V2WC44K..	H5
105	7 1/2	15	25	30	60	75	45	2	2	V2WB45K..	V4	V2WC45K..	H5
	10	-	30	30	75	100	46	2	2	V2WB46K..		V2WC46K..	

[Ⓞ] Factory will automatically select the circuit breaker based on standard or given motor full-load current and the following:
 - Continuous-current rating of a minimum 115% of motor full-load current.
 - Trip-setting position is 11 times motor full load current.

Two Speed Starters

Fusible Switch Combination and Non-Fusible Starter

Selection

Standard Features	Ordering Information Required	Coil Voltage Codes		
		ACV 60 Hz	ACV 50 Hz	Coil Suffix
<ul style="list-style-type: none"> For auxiliary contacts provided, see Selection Table below. 1 NC auxiliary contact of each contactor is used for the electrical interlock. Class 10 bimetallic overload relays including: <ul style="list-style-type: none"> - Manual or Automatic reset - Phase Loss Protection - Separate Trip and Alarm contact All enclosures are designed to accept a standard sized control transformer All enclosures have provisions for up to 4 pilot devices 	<ul style="list-style-type: none"> Select basic type nr. from table below Add suffix for both overload relay setting range from page 15-23 Add suffix for factory modification from page 15-24 to 15-28 	24	20	C
		120	110	K
		208	-	M
		240	220	P
		460	380	V
		600	-	T
		other voltages and frequencies are available upon request		

The type numbers in the selection table below specify 120V 60 Hz coils. If a different coil voltage is required, change the "K" (7 digit) as per Coil Suffix Table above.

Fusible Switch Combinations and Non-Fusible Starters														
Enclosed Amps	CSA MAXIMUM HP RATING						FUSE CLIPS Type IIC Amps	Contactor reference number	Aux, Contacts supplied as standard per contactor		Enclosure Sheet Metal			
	1 phase		3 phase								CSA / EEMAC Type 1 General Purpose Enclosure		CSA Type 5 / EEMAC Type 12 Industrial Use	
	115V	230V	200V	230V	460V	575V			NO	NC	Catalogue Number	Encl. Fig.	Catalogue Number	Encl. Fig.
20	1/4	3/4	1 1/2	2	3	5	NONE 30	15	2	2	V3WB15K.. V4WB15K..	V3	V3WC15K.. V4WC15K..	H3
	1/3	1	2	3	5	7 1/2	NONE 30	16	2	2	V3WB16K.. V4WB16K..		V3WC16K.. V4WC16K..	
	1/2	2	3	3	7 1/2	10	NONE 30	17	2	2	V3WB17K.. V4WB17K..		V3WC17K.. V4WC17K..	
35	1	3	5	5	10	15	NONE 30 60	25	2	2	V3WB25K.. V4WB25K.. V4WB25K..	V3	V3WC25K.. V4WC25K.. V4WC25K..	H3
	2	3	7 1/2	7 1/2	15	20	NONE 30 60	26	2	2	V3WB26K.. V4WB26K.. V4WB26K..		V3WC26K.. V4WC26K.. V4WC26K..	
	2	5	7 1/2	10	20	25	NONE 30 60	33	2	2	V3WB33K.. V4WB33K.. V4WB33K..		V3WC33K.. V4WC33K.. V4WC33K..	
45	2	5	10	10	25	30	NONE 30 60	34	2	2	V3WB34K.. V4WB34K.. V4WB34K..	V3	V3WC34K.. V4WC34K.. V4WC34K..	H3
55	3	7 1/2	10	15	30	40	NONE 30 60	35	2	2	V3WB35K.. V4WB35K.. V4WB35K..	V3	V3WC35K.. V4WC35K.. V4WC35K..	H3
	3	10	15	15	40	50	NONE 30 60 100	36	2	2	V3WB36K.. V4WB36K.. V4WB36K.. V4WB36K..		V3WC36K.. V4WC36K.. V4WC36K.. V4WC36K..	
90	5	15	20	25	50	60	NONE 30 60 100	44	2	2	V3WB44K.. V4WB44K.. V4WB44K.. V4WB44K..	V4	V3WC44K.. V4WC44K.. V4WC44K.. V4WC44K..	H5
105	7 1/2	15	25	30	60	75	NONE 60 100 200	45	2	2	V3WB45K.. V4WB45K.. V4WB45K.. V4WB45K..	V4	V3WC45K.. V4WC45K.. V4WC45K.. V4WC45K..	H5
	10	-	30	30	75	100	NONE 200	46	2	2	V3WB46K.. V4WB46K..		V3WC46K.. V4WC46K..	

15 LOW VOLTAGE MOTOR STARTERS

Two Speed Starters

Non-Combination

Selection

Standard Features	Ordering Information Required	Coil Voltage Codes		
		ACV 60 Hz	ACV 50 Hz	Coil Suffix
<ul style="list-style-type: none"> Mechanical and electrical interlock 2 NO + 2 NC auxiliary contacts per contactor. For the electrical interlock, a N.C. contact is provided separately. Class 10 bimetal overload relays including: <ul style="list-style-type: none"> Manual or Automatic reset Phase Loss Protection Separate Trip and Alarm contact All enclosures are designed to accept a standard sized control transformer All enclosures have provisions for up to 4 pilot devices 	<ul style="list-style-type: none"> Select basic type nr. from table below Add suffix for both overload relay setting range from page 15-23 Add suffix for factory modification from page 15-24 to 15-28 	24	20	C
		120	110	K
		208	-	M
		240	220	P
		460	380	V
		600	-	T
		other voltages and frequencies are available upon request		

The type numbers in the selection table below specify 120V 60 Hz coils. If a different coil voltage is required, change the "K" (7 digit) as per Coil Suffix Table above.

Non-Combination											
Enclosed Amps	3 phase				Contactor reference number	Aux, Contacts supplied as standard per contactor		Enclosure Sheet Metal			
	200V	230V	460V	575V		NO	NC	CSA / EEMAC Type 1 General Purpose Enclosure		CSA Type 5 / EEMAC Type 12 Industrial Use	
								Catalogue Number	Encl. Fig.	Catalogue Number	Encl. Fig.
20	1 1/2	2	3	5	15	2	2	V1NB15K..	V2	V1NC15K..	H2
	2	3	5	7 1/2	16	2	2	V1NB16K..		V1NC16K..	
	3	3	7 1/2	10	17	2	2	V1NB17K..		V1NC17K..	
35	5	5	10	15	25	2	2	V1NB25K..	V2	V1NC25K..	H2
	7 1/2	7 1/2	15	20	26	2	2	V1NB26K..	V2	V1NC26K..	H2
	7 1/2	10	20	25	33	2	2	V1NB33K..	V3	V1NC33K..	H2
45	10	10	25	30	34	2	2	V1NB34K..	V3	V1NC34K..	H2
55	10	15	30	40	35	2	2	V1NB35K..	V3	V1NC35K..	H2
	15	15	40	50	36	2	2	V1NB36K..		V1NC36K..	
90	20	25	50	60	44	2	2	V1NB44K..	V4	V1NC44K..	H3
105	25	30	60	75	45	2	2	V1NB45K..	V4	V1NC45K..	H3
	30	30	75	100	46	2	2	V1NB46K..		V1NC46K..	

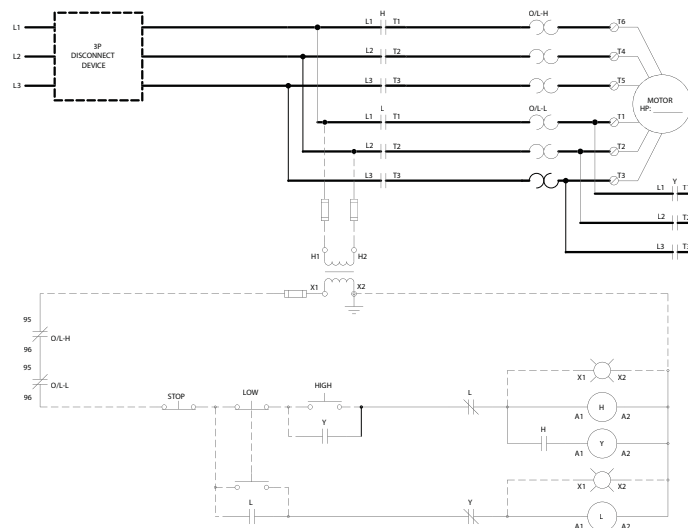

2S1W Typical Wiring Diagram

Two Speed Starters

Circuit Breaker Combination

Selection

Standard Features	Ordering Information Required	Coil Voltage Codes		
		ACV 60 Hz	ACV 50 Hz	Coil Suffix
<ul style="list-style-type: none"> ▪ Mechanical and electrical interlock ▪ 2 NO + 2 NC auxiliary contacts per contactor. For the electrical interlock, a N.C. contact is provided separately. ▪ Class 10 bimetallic overload relays including: <ul style="list-style-type: none"> - Manual or Automatic reset - Phase Loss Protection - Separate Trip and Alarm contact ▪ All enclosures are designed to accept a standard sized control transformer ▪ All enclosures have provisions for up to 4 pilot devices 	<ul style="list-style-type: none"> ▪ Select basic type nr. from table below ▪ Add suffix for both overload relay setting range from page 15-23 ▪ Add suffix for factory modification from page 15-24 to 15-28 	24	20	C
		120	110	K
		208	-	M
		240	220	P
		460	380	V
		600	-	T
		other voltages and frequencies are available upon request		

The type numbers in the selection table below specify 120V 60 Hz coils. If a different coil voltage is required, change the "K" (7 digit) as per Coil Suffix Table above.

Circuit Breaker Combination [Ⓞ]											
Enclosed Amps	3 phase				Contactor reference number	Aux. Contacts supplied as standard per contactor		Enclosure Sheet Metal			
								CSA / EEMAC Type 1 General Purpose Enclosure		CSA Type 5 / EEMAC Type 12 Industrial Use	
	200V	230V	460V	575V		NO	NC	Catalogue Number	Encl. Fig.	Catalogue Number	Encl. Fig.
20	1 ^{1/2}	2	3	5	15	2	2	V2NB15K..	V3	V2NC15K..	H3
	2	3	5	7 ^{1/2}	16	2	2	V2NB16K..		V2NC16K..	
	3	3	7 ^{1/2}	10	17	2	2	V2NB17K..		V2NC17K..	
35	5	5	10	15	25	2	2	V2NB25K..	V3	V2NC25K..	H3
	7 ^{1/2}	7 ^{1/2}	15	20	26	2	2	V2NB26K..		V2NC26K..	
	7 ^{1/2}	10	20	25	33	2	2	V2NB33K..		V2NC33K..	
45	10	10	25	30	34	2	2	V2NB34K..	V3	V2NC34K..	H3
55	10	15	30	40	35	2	2	V2NB35K..	V3	V2NC35K..	H3
	15	15	40	50	36	2	2	V2NB36K..		V2NC36K..	
90	20	25	50	60	44	2	2	V2NB44K..	V4	V2NC44K..	H5
105	25	30	60	75	45	2	2	V2NB45K..	V4	V2NC45K..	H5
	30	30	75	100	46	2	2	V2NB46K..		V2NC46K..	

[Ⓞ] Factory will automatically select the circuit breaker based on standard or given motor full-load current and the following:
 - Continuous-current rating of a minimum 115% of motor full-load current.
 - Trip-setting position is 11 times motor full load current.

Two Speed Starters

Fusible Switch Combination and Non-Fusible Starters

Selection

Standard Features	Ordering Information Required	Coil Voltage Codes		
		ACV 60 Hz	ACV 50 Hz	Coil Suffix
<ul style="list-style-type: none"> Mechanical and electrical interlock 2 NO + 2 NC auxiliary contacts per contactor. For the electrical interlock, a N.C. contact is provided separately. Class 10 bimetallic overload relays including: <ul style="list-style-type: none"> Manual or Automatic reset Phase Loss Protection Separate Trip and Alarm contact All enclosures are designed to accept a standard sized control transformer All enclosures have provisions for up to 4 pilot devices 	<ul style="list-style-type: none"> Select basic type nr. from table below Add suffix for both overload relay setting range from page 15-23 Add suffix for factory modification from page 15-24 to 15-28 	24	20	C
		120	110	K
		208	-	M
		240	220	P
		460	380	V
		600	-	T
other voltages and frequencies are available upon request				

The type numbers in the selection table below specify 120V 60 Hz coils. If a different coil voltage is required, change the "K" (7 digit) as per Coil Suffix Table above.

Fusible Switch Combinations and Non-Fusible Starters												
Enclosed Amps	3 phase				FUSE CLIPS Type IIC Amps	Contactor reference number	Aux, Contacts supplied as standard per contactor		Enclosure Sheet Metal			
	200V	230V	460V	575V			NO	NC	CSA / EEMAC Type 1 General Purpose Enclosure		CSA Type 5 / EEMAC Type 12 Industrial Use	
									Catalogue Number	Encl. Fig.	Catalogue Number	Encl. Fig.
20	1 1/2	2	3	5	NONE 30	15	2	2	V3NB15K.. V4NB15K..	V3	V3NC15K.. V4NC15K..	H3
	2	3	5	7 1/2	NONE 30	16	2	2	V3NB16K.. V4NB16K..		V3NC16K.. V4NC16K..	
	3	3	7 1/2	10	NONE 30	17	2	2	V3NB17K.. V4NB17K..		V3NC17K.. V4NC17K..	
35	5	5	10	15	NONE 30 60	25	2	2	V3NB25K.. V4NB25K.. V4NB25K..	V3	V3NC25K.. V4NC25K.. V4NC25K..	H3
	7 1/2	7 1/2	15	20	NONE 30 60	26	2	2	V3NB26K.. V4NB26K.. V4NB26K..		V3NC26K.. V4NC26K.. V4NC26K..	
	7 1/2	10	20	25	NONE 30 60	33	2	2	V3NB33K.. V4NB33K.. V4NB33K..		V3NC33K.. V4NC33K.. V4NC33K..	
45	10	10	25	30	NONE 30 60	34	2	2	V3NB34K.. V4NB34K.. V4NB34K..	V3	V3NC34K.. V4NC34K.. V4NC34K..	H3
55	10	15	30	40	NONE 30 60	35	2	2	V3NB35K.. V4NB35K.. V4NB35K..	V3	V3NC35K.. V4NC35K.. V4NC35K..	H3
	15	15	40	50	NONE 30 60 100	36	2	2	V3NB36K.. V4NB36K.. V4NB36K.. V4NB36K..		V3NC36K.. V4NC36K.. V4NC36K.. V4NC36K..	
90	20	25	50	60	NONE 30 60 100	44	2	2	V3NB44K.. V4NB44K.. V4NB44K.. V4NB44K..	V4	V3NC44K.. V4NC44K.. V4NC44K.. V4NC44K..	H5
105	25	30	60	75	NONE 60 100 200	45	2	2	V3NB45K.. V4NB45K.. V4NB45K.. V4NB45K..	V4	V3NC45K.. V4NC45K.. V4NC45K.. V4NC45K..	H5
	30	30	75	100	NONE 200	46	2	2	V3NB46K.. V4NB46K..		V3NC46K.. V4NC46K..	

Overload Relay Chart

Selection

Append to Catalogue Number V4AB15K __		The overload relay calibration is based on a motor service factor (S.F) of 1.15. If the service factor is 1.0, multiply motor F.L.C. by 0.9 before making selection.						
Adjustment Range Amps	Contactor Reference in Type No. (5. and 6. digit)							
	15 / 16 / 17		25 / 26		33 / 34 / 35 / 36		44 / 45 / 46	
	Overload Type	Overload Suffix	Overload Type	Overload Suffix	Overload Type	Overload Suffix	Overload Type	Overload Suffix
0.11 - 0.16 0.14 - 0.2 0.18 - 0.25	3RU2116	0A 0B 0C						
0.22 - 0.32 0.28 - 0.4 0.35 - 0.5		0D 0E 0F						
0.45 - 0.63 0.55 - 0.8 0.7 - 1.0		0G 0H 0J						
0.9 - 1.25 1.1 - 1.6 1.4 - 2		0K 1A 1B						
1.8 - 2.5 2.2 - 3.2 2.8 - 4		1C 1D 1E	3RU2126	1C 1D 1E				
3.5 - 5 4.5 - 6.3 5.5 - 8		1F 1G 1H		1F 1G 1H	3RU1136	1H		
7 - 10 9 - 12 9 - 12.5		1J 1K		1J - 1K		1J - 1K		
11 - 16 14 - 20 17 - 22				4A 4B 4C		4A 4B -		
18 - 25 20 - 25 22 - 32				- 4D		4D - 4E	3RU1146	4D - 4E
28 - 40 36 - 45 36 - 50						4F 4G -		4F - 4H
40 - 50 45 - 63 57 - 75						4H		- 4J 4K
70 - 90 80 - 100								4L 4M

15
LOW VOLTAGE
MOTOR STARTERS

Other Options	Suffix
Provision only for field amounting of overload relay	00
Substitute bimetal overload relay with solid state type 3RB2, Class 20	RB

Factory Modifications

Power Line Voltage and Control Circuit Options

Selection

Power Line Voltage Selection		Append to Catalogue Number i.e.: V4AB15K1E__						
		120V	200V	230V	460V	575V	600V Max.	Other
Single Phase, 60Hz (L1, N)	Suffix	1	-	-	-	-	-	-
Single Phase, 60Hz (L1, L2)		-	-	7	-	-	-	-
Three Phases, 60Hz (L1, L2, L3)		-	2	3	4	5	-	-
Three Phases, 60Hz (L1, L2, L3, N), 4-wire (Neutral)		-	8	-	-	-	-	-
Three Phases, 600V Max, 60Hz(L1, L2, L3)		-	-	-	-	-	6	-
Specify voltage, frequency, No. of phase & neutral if required		-	-	-	-	-	-	3

Note: Power line voltage is an important data to be known in order to provide a starter properly connected for single phase or three phase load.

Control Circuit Selection

Power Line Voltage Selection	Append to Catalogue Number i.e.: V4AB15K1E__	
	Contactors Reference No.	Suffix
Separate Control Circuit, Unfused		0
Separate Control Circuit, Fused, 1 fuse max. 250V		N
1 Control Fuse, max. 250V		P
2 Control Fuses, max. 600V		L
Control Circuit Transformer: Standard Standard Standard Standard for Starter Type Prim./Sec. Voltage		
FVNR } 208/120		R
FVR } 230/120		R
2S2W } 460/120		R
2SW } 575/120		R
Control Circuit Transformer: Extra Capacity		
May require larger enclosure	additional 50VA	U
Consult Siemens	100VA	W
Special transformer voltages Specify		9

Factory Modifications

Circuit Breaker Combination, Constant or Variable Torque

Selection

Additional Auxiliary Contacts

Append to Catalogue Number ie: V4AB15K1E5R_		
The max. allowable number of auxiliary contacts per contactor is 4 except for contactor 15/16/17 which can accept 5	Suffix	
Std. auxiliary contacts as per starter selection table	0	Option Available for contactors type: 15 / 16 / 17 Other contactors will come equipped as standard with 2NO+2NC
Addition of: 2 N.O. 2 N.C. 4 N.O. 3 N.O. + 1 N.C. 2 N.O. + 2 N.C.	L F K E J M	

Pilot Devices – Operators

Legend Plates are supplied as standard with Operators

Append to Catalogue Number i.e.: V4AB30K1E5R0_ _					
Operator Description	First Suffix [Ⓞ]	EEMAC Enclosure Type	English Legend	Second Suffix	French Legend
None	0	1/12 4	–	–	–

Pushbutton

1 pushbutton momentary	extended head red 1 N.C.	1 (2)	1/12 4	EMERGENCY STOP STOP	A B	ARRET D'URGENCE ARRET
twist lock maintained	mushroom red 1 N.C.	3 (4)	1/12 4	EMERGENCY STOP	A	ARRET D'URGENCE
2 pushbuttons momentary	1 - red 1 N.C. 1 - green 1 N.O.	5 (6)	1/12 4	START STOP ON OFF	C D	MARCHE ARRET EN HORS
3 pushbuttons momentary	1 - red 1 N.C. E 2 - black each 1 N.O.	7 (8)	1/12 4	FORWARD REVERSE STOP HIGH LOW STOP UP DOWN STOP FAST SLOW STOP OPEN CLOSE STOP	E F G H J	AVANT ARRIERE ARRET HAUTE BASSE ARRET EN HAUT EN BAS ARRET VITE LENTEMENT ARRET OUVRIR FERMER ARRET

15
LOW VOLTAGE
MOTOR STARTERS

ⓄWhen ordering French legend plates use the “first suffix” in brackets.

Factory Modifications

Power Line Voltage and Control Circuit Options

Selection

Pilot Devices – Operators (continued)

Legend Plates are supplied as standard with Operators

Append to Catalogue Number i.e.: V4AB30K1E5R0_ _					
Operator Description	First Suffix ^①	EEMAC Enclosure Type	English Legend	Second Suffix	French Legend

2-position selector switch

2 position selector switch maintained	1 N.O.	A (B)	1/12 4	STOP START OFF ON HAND AUTO FOR REV HIGH LOW UP DOWN FAST SLOW OPEN CLOSE LOCAL REMOTE	K L M N P Q R S T	ARRET MARCHE HORS EN MAN AUTO AVANT ARRIERE HAUTE BASSE HAUT BAS VITE LENT OUVRIR FERMER LOCAL A DIST.
2 position selector switch spring return	1 N.O.	C (D)	1/12 4			
2 position selector switch key operated maintained	1 N.O.	E (F)	1/12 4			

3-position selector switch

3 position selector switch maintained	2 x 1 N.O.	G (H)	1/12 4	HAND OFF AUTO FOR OFF REV HIGH OFF LOW UP OFF DOWN FAST OFF SLOW OPEN OFF CLOSE LOCAL OFF REMOTE TEST OFF AUTO	1 2 3 4 5 6 7 8	MAN ARRET AUTO AVANT ARRET ARRIERE HAUTE ARRET BASSE HAUT ARRET BAS VITE ARRET LENT OUVRIR ARRET FERMER LOCAL HORS A DIST. ESSAI ARRET AUTO
3 position selector switch 1 spring return from both sides	2 x 1 N.O.	J (K)	1/12 4			
3 position selector switch key operated maintained	2 x 1 N.O.	L (M)	1/12 4			
3 position selector switch key operated spring return from both sides	2 x 1 N.O.	N (P)	1/12 4			

2 pushbuttons & 3-position selector switch

3 position selector switch maintained c/w START STOP pushbuttons momentary green	2 x 1 N.O. 1 N.C. 1 N.O.	T (U)	1/12 4	HAND OFF AUTO for selector switch and START STOP for pushbutton	X	MAN ARRET AUTO for selector switch and MARCHE ARRET for pushbuttons
--	--------------------------------	-------	-----------	---	---	---

Pilot Devices – Indicators

Append to Catalogue Number i.e.: V4AB15K1E5R05C _ _ _		
Pilot Lights Description	First Suffix ^①	Enclosure Type
No Pilot Lights	0	1/4/12
Full Voltage c/w legend plate(s) 120V incandescent	1 (2)	1/12 4
Full Voltage 24V incandescent	3 (4)	1/12 4
LED c/w legend plate(s) 120V extended life	5 (6)	1/12 4
LED c/w legend plate(s) 24V extended life	7 (8)	1/12 4
Full Voltage without legend plate(s) 120V incandescent	A	1/12 4
Full Voltage without legend plate(s) 24V incandescent	B	1/12 4
LED without legend plate(s) 120V extended life	C	1/12 4
LED without legend plate(s) 24V extended life	D	1/12 4

① When ordering French legend plates use the "first suffix" in brackets.

Factory Modifications

Pilot Device Options

Selection

Pilot Lights

Legend Plates and Lens Colours

Table A - One Pilot Light								
LEGEND PLATES			LEGEND COLOURS					Other Specify
English	French		Red	Yellow	Green	Blue		
RUN	MARCHE	Suffix	1C	1D	1E	-		19
ON	EN CIRCUIT		2C	2D	2E	-		29
OFF	ARRÊT		3C	3D	3E	-		39
O/L TRIPPED	SURCHARGE		4C	4D	-	-		49
READY	PRÊT		5C	5D	5E	5F		59
Other Legend Plates Specify			9C	9D	9E	9F		99

Table B - Two Pilot Lights									
LEGEND PLATES			LEGEND COLOURS					Other Specify	
English	French		Red Red	Green Green	Red Yellow	Red Green	Green Red		Green Yellow
RUN ■ OFF	MARCHE ■ ARRÊT	Suffix	-	-	-	64	65	-	69
ON ■ OFF	EN CIRCUIT ■ ARRÊT		-	-	-	74	75	-	79
RUN ■ O/L TRIPPED	MARCHE ■ SURCHARGE		-	-	83	-	85	86	89
ON ■ O/L TRIPPED	EN CIRCUIT ■ SURCHARGE		-	-	A3	-	A5	A6	A9
FORWARD ■ REVERSE	AVANT ■ ARRIERE		B1	B2	-	B4	B5	-	B9
FAST ■ SLOW	VITE ■ LENTEMENT		C1	C2	-	C4	C5	-	C9
UP ■ DOWN	EN HAUT ■ EN BAS		D1	D2	-	D4	D5	-	D9
HIGH ■ LOW	HAUT ■ BAS		E1	E2	-	E4	E5	-	E9
Other Legend Plates Specify			91	92	93	94	95	96	99

Table B - Three Pilot Lights									
LEGEND PLATES			LEGEND COLOURS					Other Specify	
English	French		Red Red Green	Green Green Red	Red Red Yellow	Green Green Yellow	Red Green Yellow		Green Red Yellow
RUN ■ OFF ■ O/L TRIPPED	MARCHE ■ ARRÊT ■ SURCHARGE	Suffix	-	-	-	-	FN	FP	F9
ON ■ OFF ■ O/L TRIPPED	EN CIRCUIT ■ ARRÊT ■ SURCHARGE		-	-	-	-	GN	GP	G9
FORWARD ■ REVERSE ■ OFF	AVANT ■ ARRIERE ■ ARRÊT		HK	HJ	-	-	-	-	H9
FAST ■ SLOW ■ OFF	VITE ■ LENTEMENT ■ ARRÊT		JK	JJ	-	-	-	-	J9
UP ■ DOWN ■ OFF	EN HAUT ■ EN BAS ■ ARRÊT		KK	KJ	-	-	-	-	K9
HIGH ■ LOW ■ OFF	HAUT ■ BAS ■ ARRÊT		LK	LJ	-	-	-	-	L9
FORWARD ■ REVERSE ■ O/L TRIPPED	AVANT ■ ARRIERE ■ SURCHARGE		-	MJ	ML	MM	MN	MP	M9
FAST ■ SLOW ■ O/L TRIPPED	VITE ■ LENTEMENT ■ SURCHARGE		-	NJ	NL	NM	NN	NP	N9
UP ■ DOWN ■ O/L TRIPPED	EN HAUT ■ EN BAS ■ SURCHARGE		-	PJ	PL	PM	PN	PP	P9
HIGH ■ LOW ■ O/L TRIPPED	HAUT ■ BAS ■ SURCHARGE		-	RJ	RL	RM	RN	RP	R9
Other Legend Plates Specify			9K	9J	9L	9M	9N	9P	99

15
LOW VOLTAGE
MOTOR STARTERS

Factory Modifications

Pilot Device Options

Selection

Miscellaneous Options:

Specify by suffix and description as required.

Append to Catalogue No i.e.: V4AB15K1E5R05C165-Z _ _ _ _ _

LOW VOLTAGE
MOTOR STARTERS
15

Description	Suffix
Disconnect Devices Auxiliary Contacts, not wired Fusible or Non-Fusible Disconnect Switch	1 N.O. & 1 N.C. 2 N.O. & 2 N.C.
Circuit Breaker	1 SPDT 2 SPDT 1 SPDT & 1 Alarm SPDT
Metering ^① Installed & wired, EEMAC Type 1 & 12 Ammeter, 3-1/2" Panel Type c/w one 5A sec. CT One extra CT Two extra CT's Voltmeter, 3-1/2" Panel Type c/w One 0-750V Pt fused 3-Phase Selector Switch Elapsed Time Meter ME Phase Failure and Phase Sequence Monitoring Relay	MA M0 MT MV MS ME MD
Control Relays and Timers ^① 4 Pole Relay, A600 2 N.O. & 2 N.C. 3 N.O. & 1 N.C. 4 N.O.	not wired wired not wired wired not wired wired
Time Delay Relays ^① 1-SPDT, B300, max 240V AC coil ON-Delay adj. up to 100s OFF - Delay adj. up to 100s	not wired wired not wired wired
Thermistor Tripping Unit ^① max. 240V AC coil, installed and wired	Auto Reset Manual Reset
Surge Suppressors for Contactors and Control Relays	
Wire Markers	

Description	Suffix
Cover Gasket available for hinged cover enclosures only (V2, V3, V4)	-
Drip Shield available for hinged cover enclosures only (V2, V3, V4)	DS
Space Heater available for hinged cover enclosures only (V2, V3, V4)	SH
Identification Name Plate Lamacoid 1-25 characters 25-50 characters	N1 N2
EEMAC Type 4 Enclosure change 4th digit in Starter Type No. from "B" to "D"	-
EEMAC Type 4X Enclosure change 4th digit in Starter Type No. from "B" to "F" and add to EEMAC Type 1 price Stainless Steel (specify) Fiberglass (specify)	-

Fuse Clips:

All Fusible Disconnect Combination Starters are supplied with Form II C fuse clips as standard.

Fuse Clip Size	Form IJ
	Suffix
30A 60A 100A 200A	PJ

Terminal Blocks

Description	Class	Suffix
Wired 3 point terminal Wired 6 point terminal Wired 9 point terminal	All	T3 T6 T9
Un-wired 3 point terminal Un-wired 6 point terminal Un-wired 9 point terminal		TC TF TI

^① Option may require larger enclosure.
Consult Siemens.

SIRIUS Pre-Assembled Starter Packages

Contactors and Contactor Assemblies (Gold, Silver and Bronze)

Selection

Siemens SIRIUS

Pre-assembled starter packages are the simple way to order starters:

- 50HP, 600V max, combination and non-combination
- Standard 1NO contact up to 10HP, 2NO+2NC contacts from 15-50 HP
- Ambient 60°C on contactors
- Fast and simple 3-prong overload/contactor connection: no coil extension required
- Standard primary and secondary fusing on control transformers
- Standard Metal 22mm SIRIUS Control Devices

SIRIUS GOLD, SILVER AND BRONZE

Starter Packages offer these standard features:

GOLD

- 50 VA 600/120V control transformer
- 3 pos. selector switch H.O.A.
- Pilot light 120V red

SILVER

- 50 VA 600/120V control transformer
- Start/Stop pushbuttons
- Pilot light 120V red

BRONZE

- No control transformer
- No pilot devices



Siemens modular line of quality Motor Control Products meets and exceeds international standards and are built to serve global markets. Here's why choosing a package is the smarter way to select a starter:

Saves Time

No more lengthy navigating through product catalogues!
GOLD, SILVER and **BRONZE** starters offer an easy 2 step approach to selecting your starter.

1. Select the starter based on Horsepower (HP) and Line Voltage.
2. Select the appropriate overload relay.

Then it's ready to install. All this convenience is now available off your distributor's shelves.

Saves Money

This unique solution for the industry's most popular full voltage non-reversing starters is competitively priced compared to other custom-engineered starters.

Saves Hassle

Ease of selection. Off the shelf availability. Competitive pricing. It's easy to see why **GOLD, SILVER** and **BRONZE** packages are the ideal solution. For serious performance and serious convenience, take a SIRIUS approach to starters.

SIRIUS Pre-Assembled Starter Packages

Contactors and Contactor Assemblies (Gold, Silver and Bronze)

Selection

Non-Combination Starter Package
Selection EEMAC Type 1 Enclosed

Catalogue Number	Pilot Devices	Control Transformer w/ Primary and Secondary fuses	CSA Maximum HP Rating				Contactor Reference Number	Enclosure Reference Number
			3 phase					
			208V	240V	480V	600V		
GOLD3R-5-600 GOLD3R-3-480 GOLD3R-2-240 GOLD3R-1.5-208	3 Position Selector Switch & Pilot Light	Included 120V sec.	1 1/2	2	3	5	15	V0
GOLD3R-7.5-600 GOLD3R-5-480 GOLD3R-3-240 GOLD3R-2-208	3 Position Selector Switch & Pilot Light	Included 120V sec.	2	3	5	7 1/2	16	V0
GOLD3R-10-600 GOLD3R-7.5-480 GOLD3R-3-240 GOLD3R-3-208	3 Position Selector Switch & Pilot Light	Included 120V sec.	3	3	7 1/2	10	17	V0
GOLD3R-15-600 GOLD3R-10-480 GOLD3R-5-240 GOLD3R-5-208	3 Position Selector Switch & Pilot Light	Included 120V sec.	5	5	10	15	25	V1
V1AB26K005R0G111C V1AB33K005R0G111C V1AB34K005R0G111C V1AB35K005R0G111C V1AB36K005R0G111C	3 Position Selector Switch & Pilot Light	Included 120V sec.	-	-	-	20 25 30 40 50	26 33 34 35 36	V1 V1 V1 V1 V1
SILVER3R-5-600 SILVER3R-3-480 SILVER3R-2-240 SILVER3R-1.5-208	Start/Stop Pushbuttons & Pilot Light	Included 120V sec.	1 1/2	2	3	5	15	V0
SILVER3R-7.5-600 SILVER3R-5-480 SILVER3R-3-240 SILVER3R-2-208	Start/Stop Pushbuttons & Pilot Light	Included 120V sec.	2	3	5	7 1/2	16	V0
SILVER3R-10-600 SILVER3R-7.5-480 SILVER3R-3-240 SILVER3R-3-208	Start/Stop Pushbuttons & Pilot Light	Included 120V sec.	3	3	7 1/2	10	17	V0
SILVER3R-15-600 SILVER3R-10-480 SILVER3R-5-240 SILVER3R-5-208	Start/Stop Pushbuttons & Pilot Light	Included 120V sec.	5	5	10	15	25	V1
V1AB26K005R05D11C V1AB33K005R05D11C V1AB34K005R05D11C V1AB35K005R05D11C V1AB36K005R05D11C	Start/Stop Pushbuttons & Pilot Light	Included 120V sec.	-	-	-	20 25 30 40 50	26 33 34 35 36	V1 V1 V1 V1 V1
BRONZE3R-5-600 BRONZE3R-7.5-600 BRONZE3R-10-600 BRONZE3R-15-600	None	None	1 1/2 2 3 5	2 3 3 5	3 5 7 1/2 10	5 7 1/2 10 15	15 16 17 25	V0 V0 V0 V1
V1AB25K00600 V1AB26K00600 V1AB33K00600 V1AB34K00600 V1AB35K00600 V1AB36K00600	None	None	5 7 1/2 7 1/2 10 10 15	5 7 1/2 10 10 15 15	10 15 20 25 30 40	15 20 25 30 40 50	25 26 33 34 35 36	V1 V1 V1 V1 V1 V1

LOW VOLTAGE
MOTOR STARTERS
15

SIRIUS Pre-Assembled Starter Packages

Contactors and Contactor Assemblies (Gold, Silver and Bronze)

Selection

Fusible Combination Starter Package Selection EEMAC Type 1 Enclosed

Catalogue Number	Pilot Devices	Control Transformer w/ Primary and Secondary fuses	CSA Maximum HP Rating				Contactor Reference Number	Enclosure Reference Number
			3 phase					
			208V	240V	480V	600V		
V4AB17K005R0G111CP V4AB26K005R0G111CP V4AB34K005R0G111CP V4AB35K005R0G111CP V4AB36K005R0G111CP	3 Position Selector Switch & Pilot Light	Included 120V sec.	-	-	-	10 20 30 40 50	17 26 34 35 36	V2 V2 V2 V2 V2
V4AB17K005R05D11CP V4AB26K005R05D11CP V4AB34K005R05D11CP V4AB35K005R05D11CP V4AB36K005R05D11CP	2 Push Buttons & Pilot Light	Included 120V sec.	-	-	-	10 20 30 40 50	17 26 34 35 36	V2 V2 V2 V2 V2
V4AB15K006000 V4AB15K006000PD V4AB16K006000 V4AB16K006000PD V4AB17K006000 V4AB17K006000PD V4AB25K006000 V4AB25K006000PD V4AB26K006000 V4AB26K006000PD	None	None	1 ^{1/2} 1 ^{1/2} 2 2 3 7 ^{1/2} 5 5 7 ^{1/2} 7 ^{1/2}	2 2 3 3 3 7 1/2 5 5 7 1/2 7 1/2	3 3 5 5 7 ^{1/2} 7 ^{1/2} 10 10 15 15	5 5 7 ^{1/2} 10 10 15 15 20 20	15 15 16 16 17 17 25 25 26 26	V0 V2 V2 V2 V2 V2 V2 V2 V2 V2

Overload Relay Selection Chart

FLA Adjustment Range Amps	Catalogue Number		
	15/16/17	25/26	33/34/35/36
0.11-0.16	3RU2116-0AB0	-	-
0.14-0.2	3RU2116-0BB0	-	-
0.18-0.25	3RU2116-0CB0	-	-
0.22-0.32	3RU2116-0DB0	-	-
0.28-0.4	3RU2116-0EB0	-	-
0.35-0.5	3RU2116-0FB0	-	-
0.45-0.63	3RU2116-0GB0	-	-
0.55-0.8	3RU2116-0HB0	-	-
0.7-1	3RU2116-0JB0	-	-
0.9-1.25	3RU2116-0KB0	-	-
1.1-1.6	3RU2116-1AB0	-	-
1.4-2	3RU2116-1BB0	-	-
1.8-2.5	3RU2116-1CB0	3RU2126-1CB0	-
2.2-3.2	3RU2116-1DB0	3RU2126-1DB0	-
2.8-4	3RU2116-1EB0	3RU2126-1EB0	-
3.5-5	3RU2116-1FB0	3RU2126-1FB0	-
4.5-6.3	3RU2116-1GB0	3RU2126-1GB0	-
5.5-8	3RU2116-1HB0	3RU2126-1HB0	3RU1136-1HB0
7-10	3RU2116-1JB0	3RU2126-1JB0	3RU1136-1JB0
9-12.5	3RU2116-1KB0	3RU2126-1KB0	3RU1136-1KB0
11-16	-	3RU2126-4AB0	3RU1136-4AB0
14-20	-	3RU2126-4BB0	3RU1136-4BB0
17-22	-	3RU2126-4CB0	-
18-25	-	-	3RU1136-4DB0
20-25	-	3RU1136-4DB0	-
22-32	-	-	3RU1136-4EB0
28-40	-	-	3RU1136-4FB0
36-45	-	-	3RU1136-4GB0
40-50	-	-	3RU1136-4HB0

15
LOW VOLTAGE
MOTOR STARTERS

Magnetic Starters

Figure 1		Non-Combination Starter EEMAC Type 1 (Lift-Off Cover)								
		Width		Height	Depth	Mfg.-Holes				
Figure 1		A	B	C	D	E	F	G	H	3
V0	MM	161.70	244.7	146	110.3	174	–	25.7	–	
	INCH	6.37	9.64	5.75	4.34	6.85	–	1.01	–	
V1	MM	241.5	320.9	178.3	187.3	268.1	–	24	–	3
	INCH	9.51	12.64	7.02	7.38	10.55	–	0.95	–	
Figure 2		Non-Combination/Combination Starter EEMAC Type 1								
		Width		Height	Depth	Mfg.-Holes				
V2	MM	264	610	210	140	548	127	28	57	3
	INCH	10.39	24	8.25	5.5	21.58	5	1.1	2.25	
V3	MM	410	640	209.6	280	578	–	28	60	4
	INCH	16.14	25.2	8.25	11	22.76	–	1.1	2.36	
V4	MM	510	900	279.6	380	838	–	28	60	4
	INCH	20.08	35.43	11.01	14.96	32.99	–	1.1	2.36	
Figure 3		Non-Combination Starter EEMAC Type 12								
		Width		Height	Depth	Mfg.-Holes				
S	MM	254	304.8	203.2	203.2	323.85	–	93.53	25.46	4
	INCH	10	12	8	8	12.75	–	0.38	1	
Figure 4		Non-Combination/Combination Starter EEMAC Type 12								
		Width		Height	Depth	Mfg.-Holes				
H2	MM	254	610	209.6	165	648	127	12	44.5	3
	INCH	10	24	8.25	6.5	25.51	5	0.47	1.75	
H3	MM	400	640	209.6	311	678	200	12	44.5	3
	INCH	15.75	25.2	8.25	12.24	26.69	7.87	0.47	1.75	
H5	MM	500	900	280	411	955.35	–	25	44.5	4
	INCH	19.69	35.43	11.02	16.18	37.61	–	0.98	1.75	

Note: All dimensions shown for reference purpose only.
Not to be used for construction purposes.