

**SIEMENS**  
*Ingenuity for life*



SIMATIC PCS 7

# SIMATIC PCS 7 Process Control System

Brochure

Edition  
2017

[usa.siemens.com/pcs7](http://usa.siemens.com/pcs7)



# Totally Integrated Automation

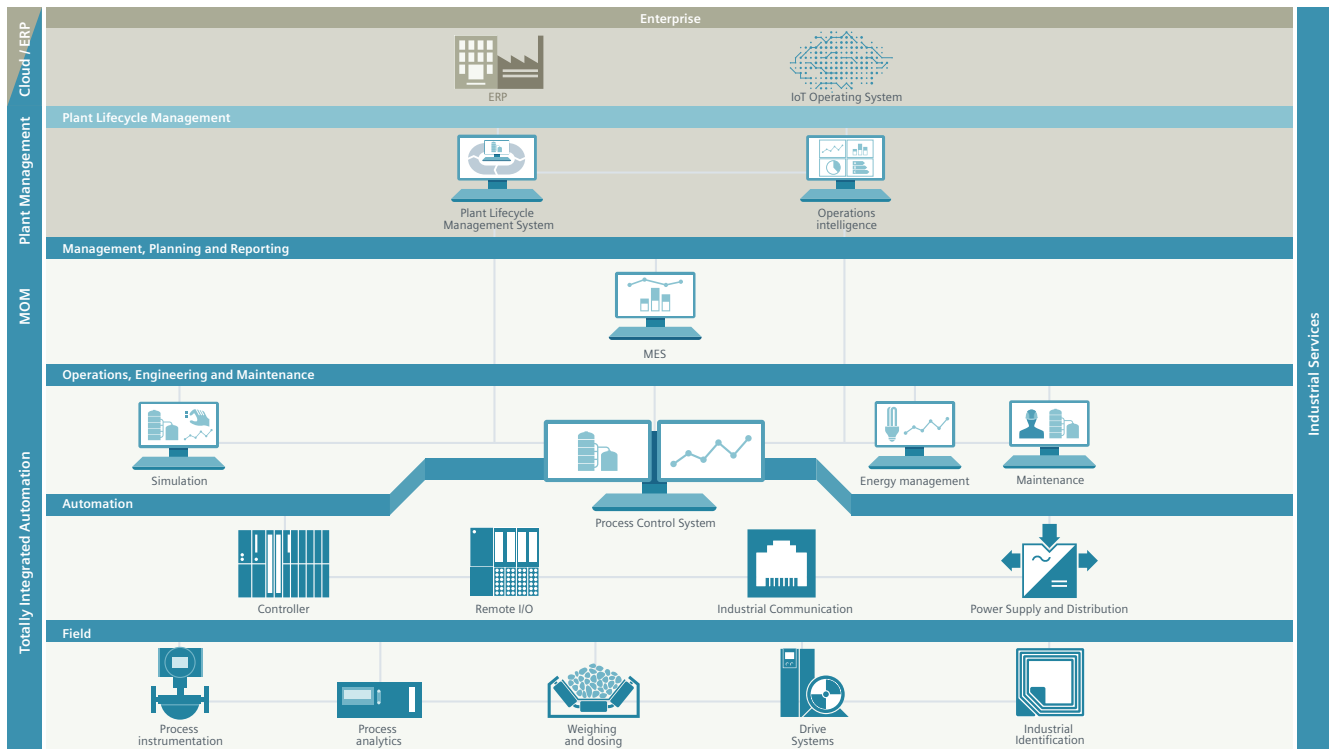

## Totally Integrated Automation: Start efficiently. Increase productivity.

In the light of the growing complexity of machines and plants along with rising engineering costs, efficient engineering is a key factor for success in the manufacturing industry.

Totally Integrated Automation, industrial automation from Siemens, makes engineering efficient. The open system architecture that covers the entire production process ensures the efficient interaction of all automation components. This is guaranteed with consistent data management, global standards and uniform hardware and software interfaces. These common features minimize the engineering overheads. This reduces costs, shortens the time to market and increases flexibility.

The holistic approach of Totally Integrated Automation paves the way for better production: faster, more flexible and more intelligent.

This, in turn, is the basis for real added value in all automation tasks, particularly:

- Integrated Engineering
- Integrated Operation
- Industrial Data Management
- Industrial Communication
- Industrial Security
- Safety Integrated

Totally Integrated Automation creates the perfect framework for strategically harnessing optimization potential - throughout the entire production process:

- Time and cost savings from efficient engineering
- Minimized downtime thanks to integrated diagnostic functions
- Greater flexibility in production due to integrated communication
- Plant and network security provided by integrated security functions
- Protection of personnel, machinery and the environment with seamlessly integrated safety technology
- Improved quality due to data consistency
- Simplified implementation of automation solutions with global standards
- Better performance with the interaction of system-tested components

## Content

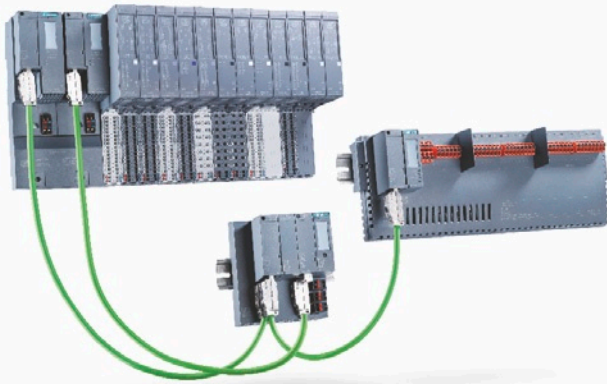

### Innovations of the SIMATIC PCS 7 Process Control System environment

When developing SIMATIC PCS 7 V9.0 – the new version of the proven process control system – focus was placed on the future-oriented possibilities of digitization down to the field level. The system solution was therefore expanded with especially powerful and compact hardware products, such as the SIMATIC ET 200SP HA and SIMATIC CFU, that support PROFINET – the world's leading Industrial Ethernet standard – and create more freedom for system design and operation.

The SIMATIC ET 200SP HA I/O system takes optimal advantage of PROFINET: Redundant PROFINET connections allow the connection of high-availability controllers via two fully separated networks, with a choice of copper or fiber-optic cables.

The combination of the SIMATIC CFU (Compact Field Unit) and the digital fieldbus and discrete I/Os makes the connection of PROFIBUS PA devices easier than ever: All devices connected to the SIMATIC CFU are automatically addressed and integrated using standard profiles.

Process Control System with Performance You Trust	
Scalability, Availability	5
Efficient top-down engineering, Operator ergonomics, Integrated asset management, Safety & security	6
Industry focus, Lifecycle management	7
System Components	
System Administration with the Management Console	10
Engineering System	11
Integrated Engineering	19
Operator System	21
Process Data Archiving and Reporting	28
Plant Device Management	30
Automation systems	37
Compact systems	42
Industrial Communication	44
Process I/O	51
Batch automation with SIMATIC BATCH	57
Route Control with SIMATIC Route Control	62
Safety Integrated for Process Automation	66
Industrial Security	72
Virtualization	74
Technology Components	
Package Units and Panel Integration	75
Telecontrol	76
Switchgear Automation	78
Energy Management with SIMATIC PCS 7	80
Optimization with Advanced Process Control	82
Simulation and Training Systems	84
Interfacing to IT systems	86
Controller Integration with PCS 7/OPEN OS	87
Migration of Our Systems	88
Support and Service	
Services	89
SIMATIC PCS 7 Lifecycle Services	91

# Process Control System with Performance You Trust

In process plants, the process control system is the interface to the process and thus the key to the optimal added value.

In competition with other control systems, the SIMATIC PCS 7 process control system from Siemens wins with high-performance tools and functions for efficient and safe plant operation. It benefits from its seamless integration in Totally Integrated Automation, a complete range of matched products, systems and solutions for all hierarchy levels of industrial automation – from the enterprise management level, to the control level, all the way down to the field level. This enables uniform, customer-specific automation in all sectors of manufacturing, process, and hybrid industry.

In this context, an essential advantage of SIMATIC PCS 7 is that faster and more precise control sequences as well as integrated security functions of shared hardware, engineering and management tools can be used for automation of continuous and discontinuous processes.

Although it is responsible for automation of primary processes in the supply chain from incoming raw material to outgoing finished goods, SIMATIC PCS 7 can also integrate all auxiliary systems, the electrical infrastructure in the form of low or medium-voltage switchgear and building management.

As a central database, SIMATIC PCS 7 is also the starting point for further optimization. Thanks to standardized interfaces, the process data is available for analysis, planning, coordination and optimization of plant sequences or production and business processes – in real time and at any location in the company!

A central engineering system with a coordinated range of tools for integrated system engineering and configuring of batch automation, safety functions, material transport or telecontrol systems creates value added over the entire lifecycle. It reduces the engineering and training costs, thus making a significant contribution to minimizing the total cost of ownership (TCO).







Outstanding features of SIMATIC PCS 7

## Scalability

The constant change in the process industry also has an impact on process plants. Plant expansion, the merging of control rooms, etc. require the control system to be flexible.

Thanks to a unique scalable system architecture, SIMATIC PCS 7 creates the ideal basis for cost-effective implementation of individual automation solutions and economic operation of process plants. When the plant grows, SIMATIC PCS 7 simply grows along with it – without the provision of expensive reserve capacities!

The scalability applies for all levels of the system. The architecture of the SIMATIC PCS 7 process control system is designed in such a manner that instrumentation and control can be configured in accordance with customer requirements and optimally matched to the dimensions of the plant. The control system can be subsequently expanded or reconfigured at any time if there is an increase in capacity or a technological modification. At the control level alone there are several functionally-compatible automation systems with graduated price/performance ratios that are available to the user. The automation performance can be optimally matched to the requirements of the plant/unit.

## Availability

Plant availability over many years is a central requirement of the industry. That is why all SIMATIC PCS 7 components are not only carefully designed and manufactured for rough industrial use, but also for redundant configurations. This especially applies to safety applications.

Thanks to the flexibly scalable fault tolerance of Safety Integrated (Flexible Modular Redundancy, FMR), the degree of redundancy can be individually defined for each of the architecture levels, controller, fieldbus and I/O and adapted to the field instrumentation. This enables the implementation of individual, fault-tolerant architectures which are precisely tailored to the individual tasks.

In addition, SIMATIC PCS 7 supports all the usual communication protocols, most of which have their own redundancy designs, such as FOUNDATION Fieldbus, PROFIBUS or PROFINET.

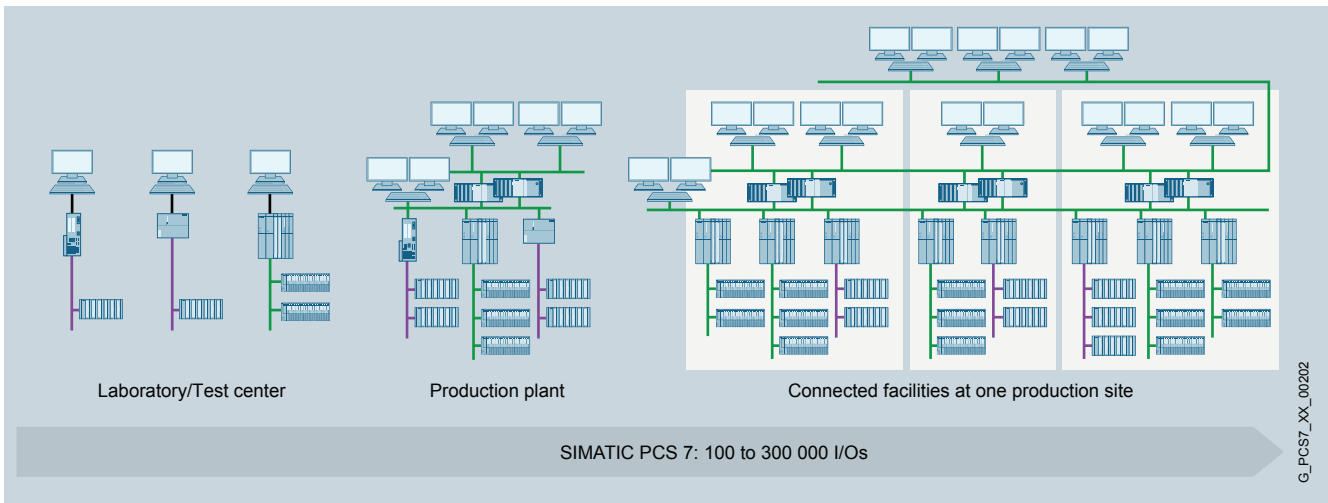

Scalability of the SIMATIC PCS 7 process control system

## Efficient top-down engineering

Short engineering phases, maximum automation and parallelization of processes that minimize errors – that is what we call engineering. Siemens has therefore developed an integrated engineering process based on consistent data management. From COMOS Plant Design to SIMIT Simulation Framework, the plant is modeled to according to the plant hierarchy with SIMATIC PCS 7.

Finely matched tools with graphical editing functions are provided for engineering the automation functions. The safety applications and the interlocks between technological functions of the automation project can be created with a cause&effect matrix conveniently and without programming skills. For mass data engineering, SIMATIC PCS 7 is also designed as for distributed, multi-user configuration around the globe.

## Operator ergonomics

Process control is becoming increasingly complex due to the multi-layer nature of automation engineering and increased merging with information technology. At the same time, simple, intuitive operation is becoming increasingly important for efficient, error-free work of operating personnel and implicit for minimizing downtime and service incidents. SIMATIC PCS 7 optimally supports operators for safe management of the process, for example, with:

- Easy-to-operate blocks of the Advanced Process Library with sophisticated functionality
- Advanced Process Graphics for focusing the process visualization on the essentials
- Advanced Process Control for the optimization of the closed loop control functions
- Alarm Management conforming to the latest standards to reduce alarm surges

## Integrated asset management

Plant components and production resources are assets that must be protected. Continuous monitoring of all automation components keeps the system available at a constantly high level.

The maintenance station integrated in SIMATIC PCS 7 provides a complete overview of the state of plant components and thus provides the basis for maintenance that effectively preserves and increases value. It is thus an important component for minimization of the total cost of ownership for the complete lifecycle of the plant.

The server-client architecture of the process device manager, SIMATIC PDM, increases flexibility and enables the service personnel at stationary and mobile workstations to have system-wide access to the field devices with a standard Web browser. The time required for the commissioning and maintenance of field devices is significantly reduced.

## Safety & security

Safety in the process industry means both safety for people, the environment and plant as well as data security and protection against unauthorized access to information. SIMATIC PCS 7 has sophisticated concepts for both aspects.

With SIMATIC Safety Integrated for Process Automation, SIMATIC PCS 7 offers an integrated range of products and services for all safety-related functions. Modularity and flexibility of the safety technology enable you to individually determine the degree of integration in the process control system and the degree of redundancy for controllers, fieldbuses and process I/O for each project. Similar to a cost analysis over the entire lifecycle of the system; complete integration of the safety engineering system proves in SIMATIC PCS 7 is the most effective in this way.





Integrated networking from the office level out to the field has many advantages, but at the same time increases the risk of threats from outside and inside. Only a comprehensive approach, such as that provided by the SIMATIC PCS 7 security concept, can provide reliable protection by combining a variety of security measures in the plant network. Additional support is provided by security specialists from Siemens with supplemental Plant Security Services over the entire lifecycle of the plant.

## Industry focus

Every industry follows its own market laws, challenges and opportunities. Siemens has integrated the industry-specific process know-how of its employees in the development of the universal SIMATIC PCS 7. The comprehensive portfolio of SIMATIC products and systems is thus enriched by many years of experience and expertise from all process industries.

With technology libraries and optional functions for batch processing, process analysis, energy management, telecontrol and switchgear equipment, laboratories, breweries, mining and cement plants etc., SIMATIC PCS 7 has proven itself in numerous process industries.

## Lifecycle management

Plants in the process industry usually live longer than the control systems used for automation and often survive several industrial PC system generations. At the same time, the use of standard IT components require frequent upgrades and security updates.

With a reasonable, forward-looking upgrade concept and the advanced planning of upgrades, Siemens helps its control system customers to avoid downtime and to save costs.

To keep the process control system up-to-date with the latest technology, Siemens provides a Software Update Service (SUS) for SIMATIC PCS 7.

The SIMATIC PCS 7 Management Console supports inventory listing of the SIMATIC PCS 7 hardware and software components as well as centralized management of software revision levels for all stations of the SIMATIC PCS 7 system. This enables fast analysis and targeted replacement and update actions.

The supportive SIMATIC PCS 7 Lifecycle Services ensure the operation and serviceability of the control system over the entire lifecycle of the plant while protecting investments. They enable predictable maintenance costs and cost-effective modernization.

# SIMATIC PCS 7

## Room for new perspectives

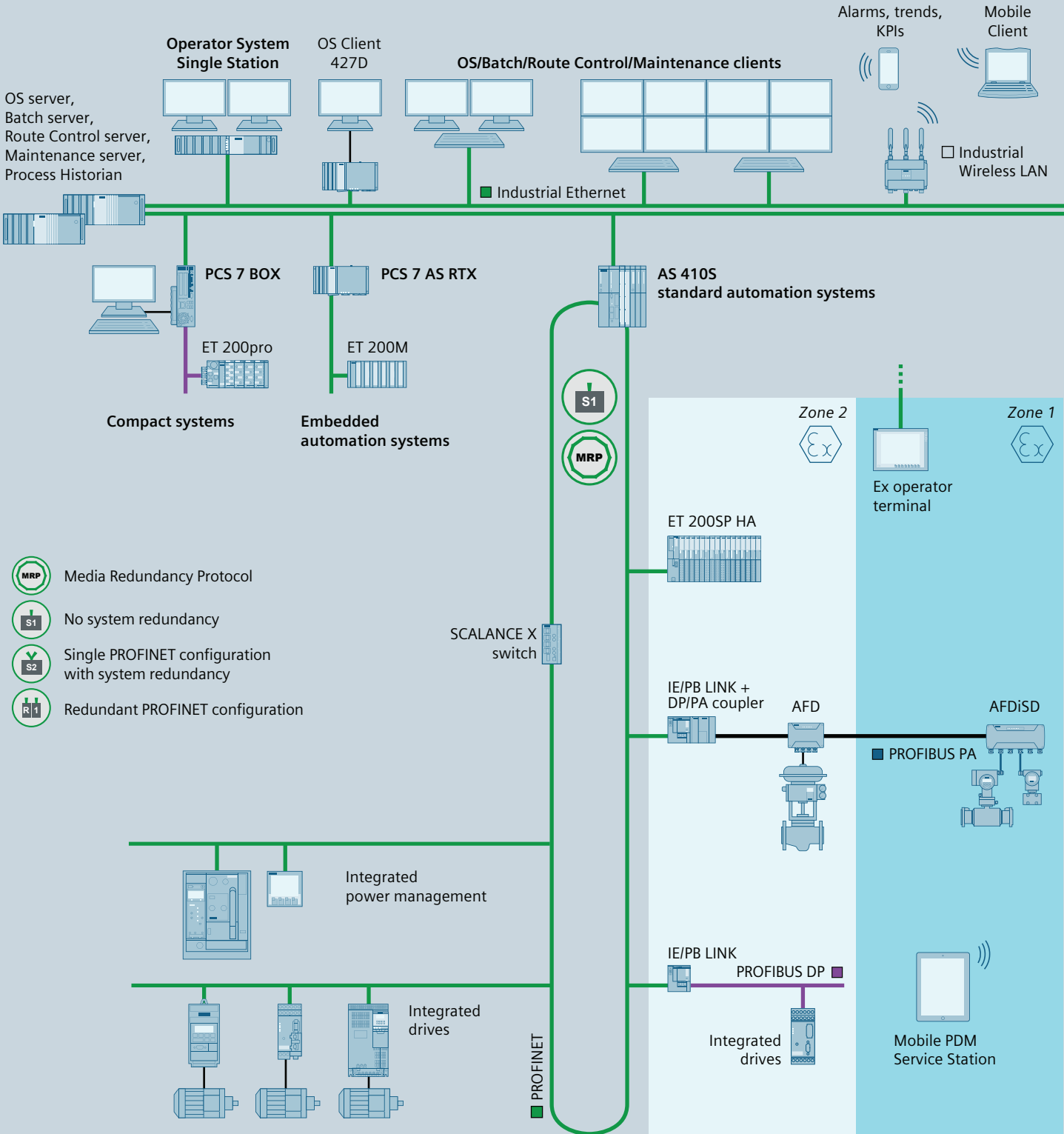



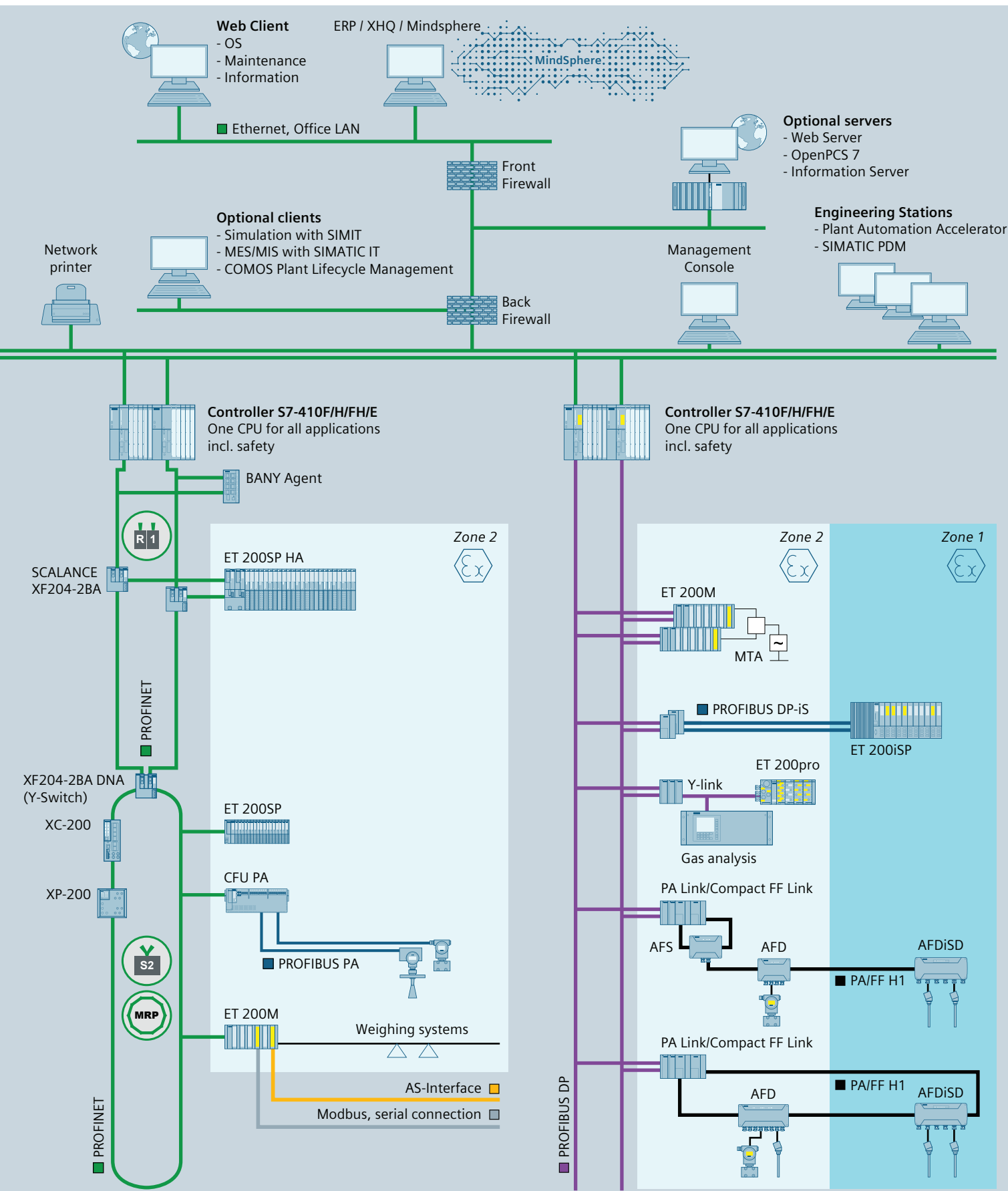

G\_PCS7\_XX\_00636

# System Administration with the Management Console

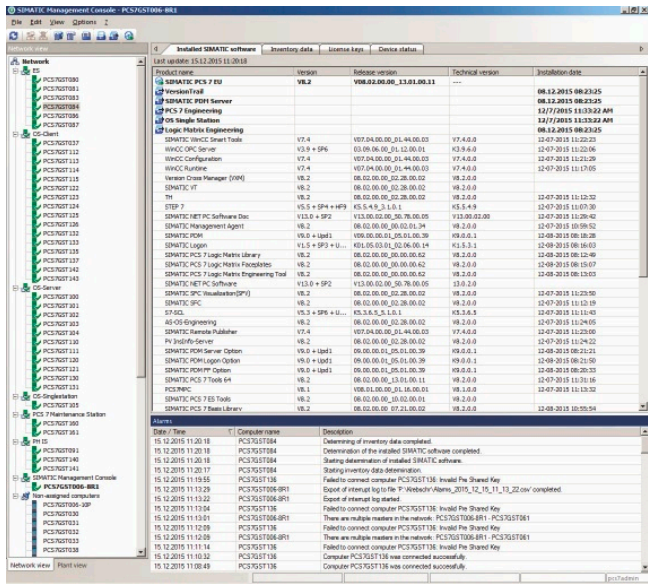

Overview of installed software status

A process control system includes numerous heterogeneous components, each with specific parameters and settings. These are subject to this dynamic modification process through updates, upgrades, modernizations and expansions. Without system support, it becomes increasingly difficult and expensive to keep track of the current state of hardware and software and continually update it as the plant gets older.

The PCS 7 Management Console can be used to minimize the administrative requirements for a single SIMATIC PCS 7 plant or a plant network. The current status of the installed hardware and software components can be called at any time.

The PCS 7 Management Console permits:

- Central, standardized administration of SIMATIC PCS 7 software
- Inventorying all hardware and software components of the plant configured with SIMATIC PCS 7

With small plants, the PCS 7 Management Console can be installed and operated on the PCS 7 Engineering Station. However, a stand-alone PCS 7 Management Console on a PCS 7 Industrial Workstation is typical for large plants or a network of plants.

The Kerberos protocol ensures secure authentication of communication between the SIMATIC PCS 7 Management Console and the stations managed by it, the Management Console agents.

## Central software administration

New SIMATIC PCS 7 installations, updates and service packs are administration components as well as upgrades to the current software version. The installation on the target station(s) does not require active participation of the user. Security mechanisms prevent impairment of runtime operation.

- Provision of installation files on a dedicated file server/ PCS 7 Management Console
- Adding/removing PCS 7 setups in the central setup management
- Creating plant-specific or user-specific pre-configured setup packages
- Rollout of pre-configured setup packages on target stations:
  - Addition of software packages during installation
  - Direct editing of uninstalled setup packages
- Checking of target stations for installation readiness
- Remote disabling of station for launching an update installation
- Monitoring the status during the entire installation and continuing the installation after restart or network disruption
- Remote enabling of a station after completion of an update installation.

## Creation of system inventory

The central creation of an inventory of installed hardware and software components simplifies the production of a detailed inventory report and permits rapid determination of candidates for upgrade and replacement actions:

- Central recording of inventory data by reading out of the engineering system or the component
- Inventory report in Microsoft Excel format
- Combination of filter results with user-defined categories
- Colored marking of filtered data
- License verification of installed software licenses

For additional information, see:

[www.siemens.com/simatic-pcs7/managementconsole](http://www.siemens.com/simatic-pcs7/managementconsole)



# Engineering System

## System-wide engineering

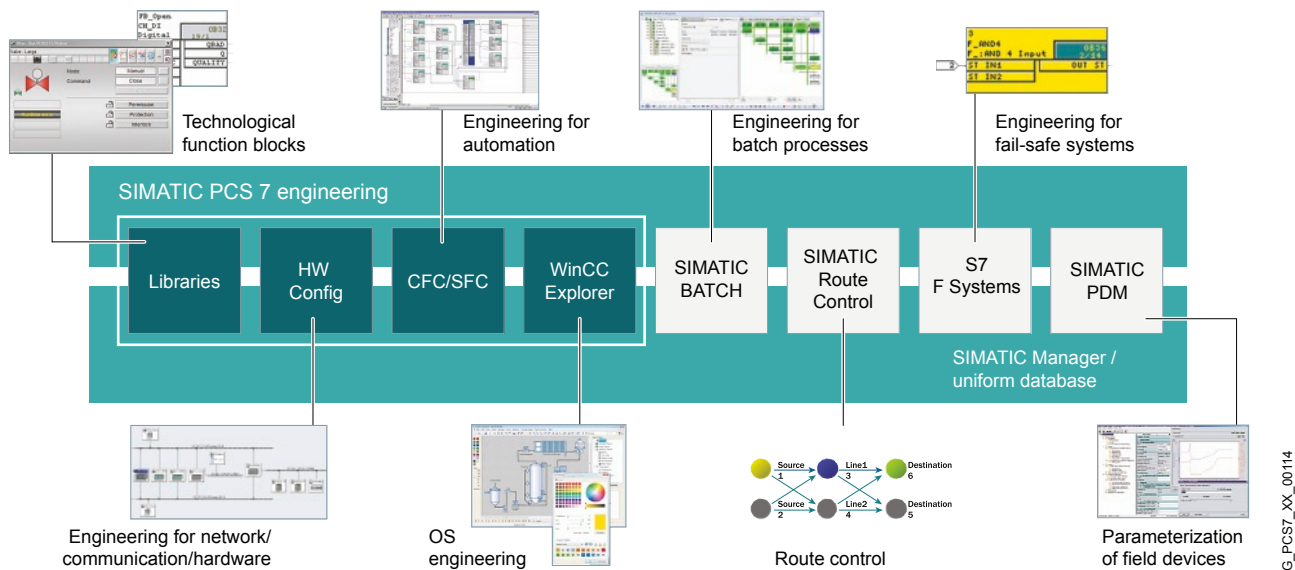

Basic functionalities in the engineering system and optional software packages

The engineering system is optimized for efficient system-wide configuration of SIMATIC PCS 7. The architecture of this engineering system depends on its use as:

- Classic, dedicated engineering station
  - Project editing on a central engineering station
  - Project editing in the engineering network (concurrent engineering, multiproject engineering)
- Combined engineering/operator station for small applications

The engineering system is based on the high-performance SIMATIC PCS7 Industrial Workstation, which can be used either in office applications or in industrial environments. You can control up to four process monitors when operating multiple monitors.

### Engineering toolset

The engineering toolset and the predefined blocks and charts enable technological as well as process and production engineers to plan and configure in their familiar environment as well. The engineering toolset provides the project engineer a perfectly coordinated set of tools for project-oriented, system-wide engineering of:

- Control system hardware including I/O and field devices
- Communication networks
- Automation functionality for continuous and batch processes (AS engineering)
- HMI functionality (OS engineering)
- Diagnostics and asset management functionality
- Batch processes, automated with SIMATIC BATCH
- Material transport, controlled by SIMATIC Route Control
- Safety applications (Safety Integrated for Process Automation)

## Project management with the SIMATIC Manager

The SIMATIC Manager is the integration platform for the engineering toolset as well as the project manager for all engineering tasks of the SIMATIC PCS 7 process control system. It is used to manage the SIMATIC PCS 7 project for archiving and documentation. The engineering tools for the application software, the hardware components and the communications functions can be called directly from the SIMATIC Manager.

### Plant hierarchy

Creating hierarchy folders implements a project structure, which is referred to as the plant hierarchy. By storing CFC and SFC charts for automation systems and pictures and reports for operator stations in a hierarchy folder along with additional documentation, the configuring engineer implicitly determines the hierarchical assignment.

### Hardware configuration

The hardware required for use in a SIMATIC project – such as automation systems, communication components and process I/Os – is stored in an electronic catalog and is configured and parameterized using the "HW Config" application.

### Encryption function for blocks

Function blocks and functions can be encrypted and decrypted with the "S7 Block Privacy" application to protect know-how. Following encryption, the blocks and their attributes can no longer be modified. Only the interfaces of the blocks are then visible.

### Graphic configuration tool

In order to implement the automation logic, predefined function blocks are linked to other blocks in the graphic configuration tool CFC. An SFC editor is available for graphical configuring and commissioning of sequential controls.

### Engineering of the operator systems

The project data for engineering of the operator systems is also organized with the SIMATIC Manager. All the data relevant to operation and monitoring of a process tag are generated automatically during definition of the automation function.

### Graphics Designer

A powerful Graphics Designer supports generation of the process displays. The basis for generating process pictures is provided by static symbols and dynamic block icons and faceplates that are managed in libraries and linked to the parameters of the function blocks.

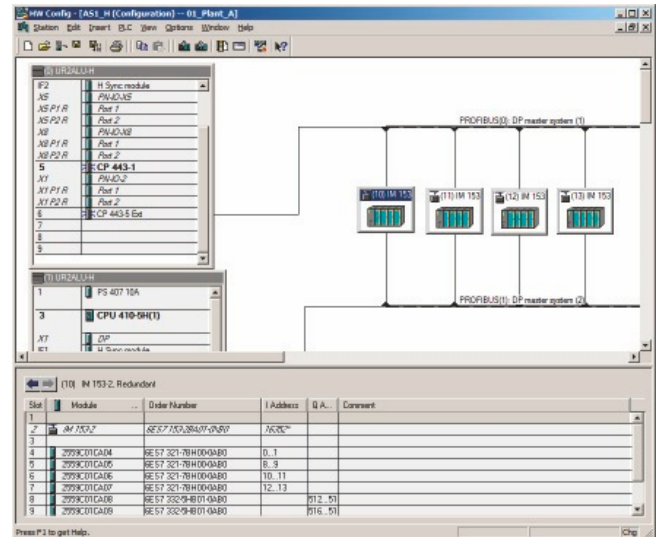

Component view: Hardware configuration with HW Config

### Selective compiling and downloading

Complete SIMATIC PCS 7 projects or all applications of a project can be compiled and loaded into the target systems in a single operation. The engineering system automatically ensures the correct sequence. A central dialog displays and controls the operation.

A more effective method for less comprehensive changes to the standard automation, e.g. addition or modification of single process tags, is selective compilation and downloading at chart level. This can be started from the plant hierarchy, from the CFC or from the chart folder.

The project engineer can recognize all changes since the last download by their color and the current chart states by means of the corresponding symbols. The project engineer can make a specific choice in a dialog form for selective downloading. In association with the Version Trail, each download is automatically followed by archiving.

In the case of blocks being executed on the AS 410 automation system, it is even possible to change types during runtime by means of seamless copying (TCiR).

The various tasks for creating a plant project are supported by the following project views:

- Component view (HW Config)  
Configuration of hardware such as automation systems, bus components or process I/Os
- Process object view  
Central development environment for all aspects of process tags/process objects



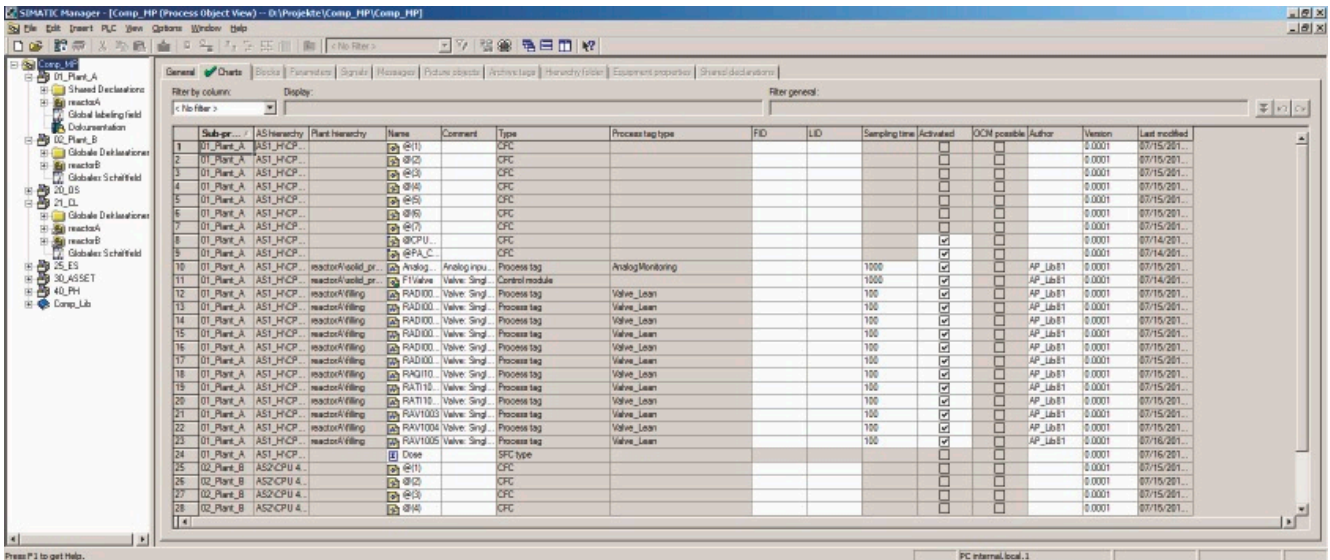

Process tags in the process object view

### Process object view

The process object view of the SIMATIC Manager supports the work carried out by a process engineer by providing a universal view of the process tag. It shows the plant hierarchy represented in tree form in combination with a tabular view of all aspects of the process tag or process object (general, charts, blocks, parameters, signals, messages, picture objects, archive variables, hierarchy folders, equipment properties and global declarations). This provides the technologist with fast orientation.

All objects in the marked branch of the hierarchy are displayed in the table so that they can be directly processed with user-friendly edit, filter, replace, import and export functions. A special test mode offers the facility for testing process tags and CFCs online and for starting them up.

The OS areas and the picture hierarchy for process control, as well as the SIMATIC PCS 7 asset management, can be derived from the plant hierarchy. This is also the basis for plant-oriented identification of process objects.

Group displays can be positioned in pictures by means of the picture hierarchy and automatically linked to subordinate pictures. The configuration engineer only has to ensure the correct positioning. Since the number of group display fields and their semantics can be configured, it is also possible to implement customized alarm configurations.

I&C messages and process messages are already pre-configured in the function blocks and operator input messages in the faceplates and they are generated automatically when the trigger event occurs. If required, message texts can be modified or message priorities defined.

### Smart alarm hiding

Messages of the technological blocks for operating states in which they are secondary to the safe and smooth operation of the plant are hidden dynamically to relieve the operator.

Hiding or display of these is individually controlled by selecting check boxes in the alarm matrix of the process object view for as many as 32 operating states. Although hidden alarms are not signaled visually and audibly, they are still logged and archived as before.

### Continuous Function Chart (CFC)

The CFC editor is used for configuration of the continuous automation functions. In addition to convenient editing functions, its scope of functions also includes powerful test and commissioning functions as well as individually configurable documentation functions.

Instances of function block types can be positioned, assigned parameters and interconnected on CFCs. Access privileges can already be assigned at the block level per block attribute, thus enabling finely graded privileges.

When creating a new CFC, a runtime group with the same name is created and automatically assigned to all blocks of this chart. Each block is therefore immediately assigned runtime properties which the configuration engineer can change or optimize using algorithms.

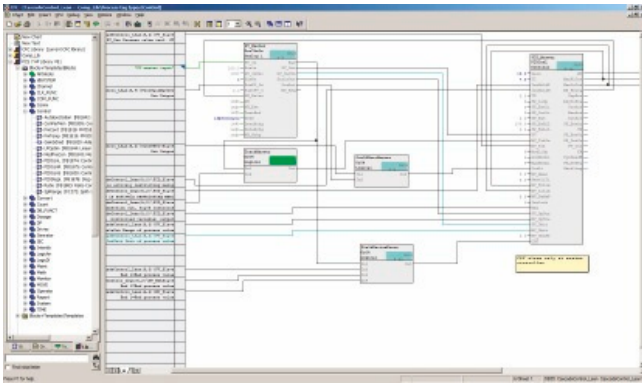

Continuous function chart in the modernized design

Special configuration techniques such as chart-in-chart for implementing hierarchical charts or the multiple uses of chart block types (individual control units/process tag types) and SFC types in the form of instances, offer additional rationalization potential.

The CFC editor supports the following types of standardized software modules:

- Function block type  
Smallest standardized software modules with connections for actuating and control signals that represent process engineering equipment such as valves or motors.
- Process tag type  
The function blocks implement standardized continuous function chart for basic automation of specific process control functions, such as fill level control.
- Control module type (CMT)

### Technological engineering with control module types

Control module types (CMT) are standardized software modules that can contain blocks, charts, control variables (block I/Os such as signals and parameters) and messages. Control modules (CM) can be synchronized with their type at any time.

When changes are made to the CMT, these can be easily applied to the instances. Instance-specific properties are retained. This enables creation of instances during type development. The difference view of the synchronization mechanism enables detailed tracking of changes. Existing process tag types can be automatically converted to CM types.

This yields the following advantages:

- Reduced testing effort through type-based testing
- Faster, repeatable work through use of types
- Reduced maintenance effort for libraries
- Parallel working reduces the project duration

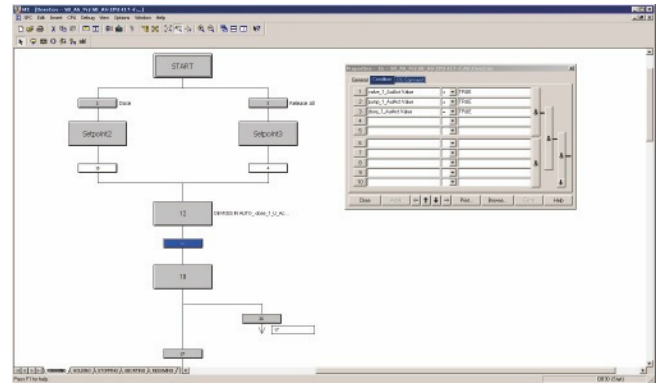

Sequential function chart in engineering

### Sequential Function Chart (SFC)

The SFC editor is used for the graphical configuration and commissioning of sequential controls for batch production operations. It possesses convenient editing functions as well as powerful test and commissioning functions. An integrated graphical formula editor for arithmetic operations, Boolean algebra and mathematical functions enables calculations within the SFC.

Using a sequential control, basic automation functions usually created using CFC are controlled and selectively processed by means of changes in operating mode and status. Sequential controls can be created either as an SFC or SFC type.

### SFC

The SFC is used to implement sequential controls which can be applied once and which access several partial areas of the production plant. Each SFC has standardized inputs and outputs for status information and for control by the user program or the user. The SFC can be positioned and interconnected in the CFC. The required CFC block I/Os are selected by simple operations and connected to the steps and transitions of the step sequences.

A status manager conforming to ISA-88 enables the configuration of up to 8 separate sequencers within a single SFC, e.g. for states such as RUNNING, HOLDING or ABORTING or for different operating modes.

### SFC type

SFC types are standardized sequential controls which can be applied repeatedly and which access one partial area of the production plant. They can be organized in libraries and handled like normal function blocks. Changes to the original automatically result in corresponding changes in all instances. An SFC type may contain up to 32 sequences. Using the function "Create/update block symbols", a block symbol is automatically positioned and interconnected in the associated process display for all SFC instances with HMI features.



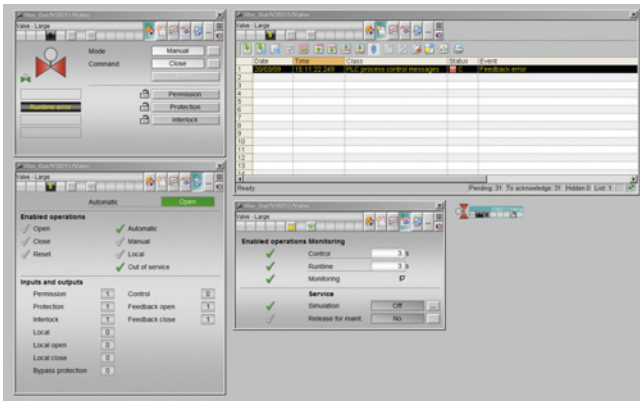

Examples of OS standard faceplates from the SIMATIC PCS 7 Advanced Process Library, Valves

### Process control libraries

The use of library elements plays a major role in minimizing the amount of engineering required and thus also the project costs. Pre-configured and tested blocks, faceplates and symbols are organized in the libraries and form the basic elements for the graphic configuration of automation solutions.

Pre-configured process tag types for process control equipment such as pumps, valves, dosers and controllers (cascade, spit-range) etc. extend the spectrum. The standard functions provided by the Advanced Process Library can be optionally expanded with the Industry Library and the Condition Monitoring Library. The library elements of all libraries are uniform in design.

#### Advanced Process Library

The Advanced Process Library (APL) is based on many years of experience of project engineers and plant operators and takes into consideration current NAMUR recommendations and PNO specifications.

The comprehensive range of blocks can be categorized as follows:

- Blocks for mathematical operations, analog and digital logic
- Interlocking blocks
- Technological function blocks with integral display, operation and signaling functions, e.g.:
  - Standard control blocks
  - Advanced Process Control blocks
  - Motor and valve blocks
  - Counter blocks
  - Dosing blocks
- Blocks for the integration of field devices
- Operator control and monitoring blocks
- Signaling and diagnostics blocks

Proven functions as well as visually attractive GUIs for a high level of operator convenience facilitate and also force interaction of operators with the plant. Highlights included features such as:

- Reduced "Small" versions of function blocks with compact faceplates and block icons
- Special operating modes
  - "Local" for integration of local control options
  - "Out of service" for deactivating a measuring point for maintenance
- Several faceplate views
  - "Preview" with information on the I/O signal status, automatic control and possible/permissible operator inputs; display of real value for simulation
  - "Memo view" for temporary operator information
- Convenient interlocking blocks with initial signal information, can be directly called from technological blocks
- Commissioning support through direct simulation on the operator station
- Protection against operator errors as the result of detailed grading of user privileges
- Explicit enabling/disabling of operations for a process tag for individual operator stations of the plant
- Integration of any compact drives and switch/starter objects via standard PROFIBUS profiles
- Coordination of multiple access operations, e.g. of SFC/SIMATIC BATCH in equipment such as valves, pumps, etc.
- Browser for the tag selection by status
- Configurable custom online trends for display
- Process tag groups that can be assembled online for standard situations relieve the operator and enable faster reactions
- Online help for the operator facilitates familiarization and operator prompting during operation

#### Industry Library

The Industry Library contains blocks for:

- Building automation (heating, ventilation, air conditioning)
- Operator control and monitoring using Comfort Panels
- Integration of SIMATIC S7 Package Units and RTUs based on SIMATIC S7-300
- Interfacing of external Advanced Process Control systems
- Hierarchical multi-control room operation
- Other technological functions, e.g. for expanding measured value monitoring or specifying a setpoint trend

#### Condition Monitoring Library

The Condition Monitoring Library contains blocks for:

- Monitoring of centrifugal pumps (PumpMon)
- Monitoring of control valves (VlvMon)
- Detection of stationary states in a dynamic process (steady state)
- Online valve test during operation (PST)
- Monitoring for pressure loss and early detection of blockages (PressDropMon)

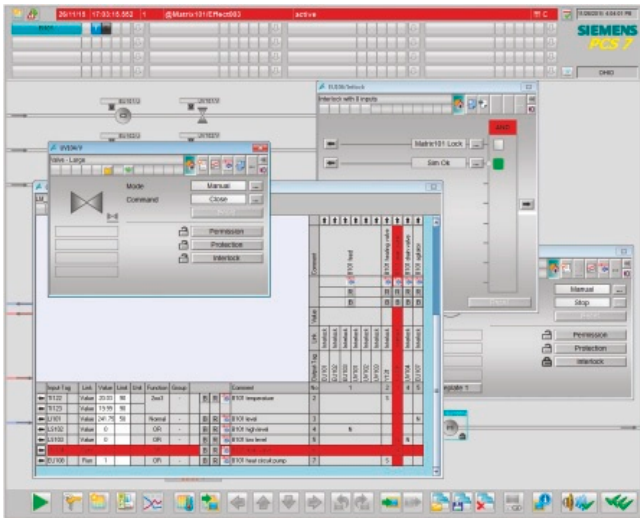

Faceplates of the Logic Matrix and the linked control module in the Logic Matrix Viewer of the SIMATIC PCS 7 operator station

### SIMATIC PCS 7 Logic Matrix

The SIMATIC PCS 7 Logic Matrix enables convenient creation of the interlock logic between technological functions (e.g. control modules or equipment modules) of the automation project using a cause&effect matrix. The matrix data can be integrated thereafter at the chart level in the CFC project. There is no time-consuming configuring of the interlock logic in the CFC.

In the Logic Matrix Editor, the project engineer links the required input signals, for example, the APL-based tag types, in the horizontal rows of a matrix table comparable to a spreadsheet. Logic operations, timing response, alarms etc. can be configured for each cause. The outputs can be linked to the effects in the vertical columns of the logic matrix in a similar manner.

The causes and effects are then logically linked through the intersections of rows and columns, allowing various reactions to be configured.

The operator can operate and monitor the logic matrix via the Logic Matrix Viewer on the SIMATIC PCS 7 operator station. The logic matrix faceplate can be opened via the corresponding faceplate or via the technological blocks concatenated in the causes and effects. Based on this causal chain, the operator can jump from the effect faceplate to the cause faceplate via the Safety Matrix faceplate.



### Access and change verification

With the SIMATIC Logon user administration, an administrator can create user groups with different access rights. Access rights for stations of the process control system and operator privileges for blocks can both be set up. Configurable modification protocols can record all access operations to the engineering system as well as all online changes. If you link the modification reports with the data of SIMATIC Logon, it is possible to verify clearly who has made a particular change and when. Such verifications are often the object of special sector-specific requirements, formulated, for example, in FDA 21 CFR Part 11 or GAMP.

### Version Cross Manager

The Version Cross Manager detects differences between different versions of a single or multi-project by tracing missing, additional or differing objects by comparing hardware configuration, communication, plant hierarchy, CFCs/SFCs, SFC details, block types, alarms, global variables, signals and run sequences

The comparison results are displayed graphically in a combination of tree and table. All differences are distinguished by a color.

### Version Trail

When used together with SIMATIC Logon, SIMATIC Version Trail is responsible for version-specific archiving of libraries, projects and multiprojects, as well as retrieving the version states from the archive. SIMATIC Logon organizes access protection for this. Archiving and retrieval procedures can be automated on a time-driven basis.

The version history managed by Version Trail can be displayed and printed. In conjunction with the Version Cross Manager, an archived version can be compared with an existing project or a second archived version.



## Shared configuration tasks

### Concurrent engineering

With concurrent engineering, multiple project engineers can work concurrently on one project in CFC and SFC, without having to split the project up into sub-projects beforehand. During commissioning, for example, charts can be used and at the same time changes can be made to the project. CFCs and SFCs can be opened and viewed multiple times, although simultaneous write access to the database is rejected. If a chart is already in use, the project engineer receives a notification.

The project is localized on one of the participating Engineering Stations, the project server. The Engineering Stations working as "Project Clients" can access the project data via LAN/WAN. A specific chart can be found very quickly using a cross-project search function.

The Graphics Designer supports parallel working on a project even when creating process displays.

### Multiproject engineering

A complex project can be divided into several subprojects in accordance with technological criteria in order to allow several teams to work on the project in parallel. To achieve this, a host "Multiproject" is defined in the SIMATIC Manager. The individual projects can be added or removed from this multiproject at any time.

The subprojects in a multiproject are stored on a central server and moved to the local engineering stations for editing. The engineering performance is thus unaffected by network access. All block types used in a multiproject can be updated centrally.

### **Project documentation**

The reporting system integrated into the engineering system can be used to document the engineering project in accordance with standards. The project report records:

- Mimic diagrams and picture objects with properties, events, actions and direct links
- Variables, properties and communication links
- Message classes, message blocks and messages
- Archive tags and configuration data for archives
- User groups and users
- Source text of actions/functions
- Texts of text library
- Basic Process Control configuration data

The project data can be freely-structured, edited in the form of standardized circuit manuals and printed in a uniform layout. You can incorporate your own cover sheets, layouts, graphics, logos or title block data. A convenient output control function allows you to select a complete project or individual parts of a project for printing.



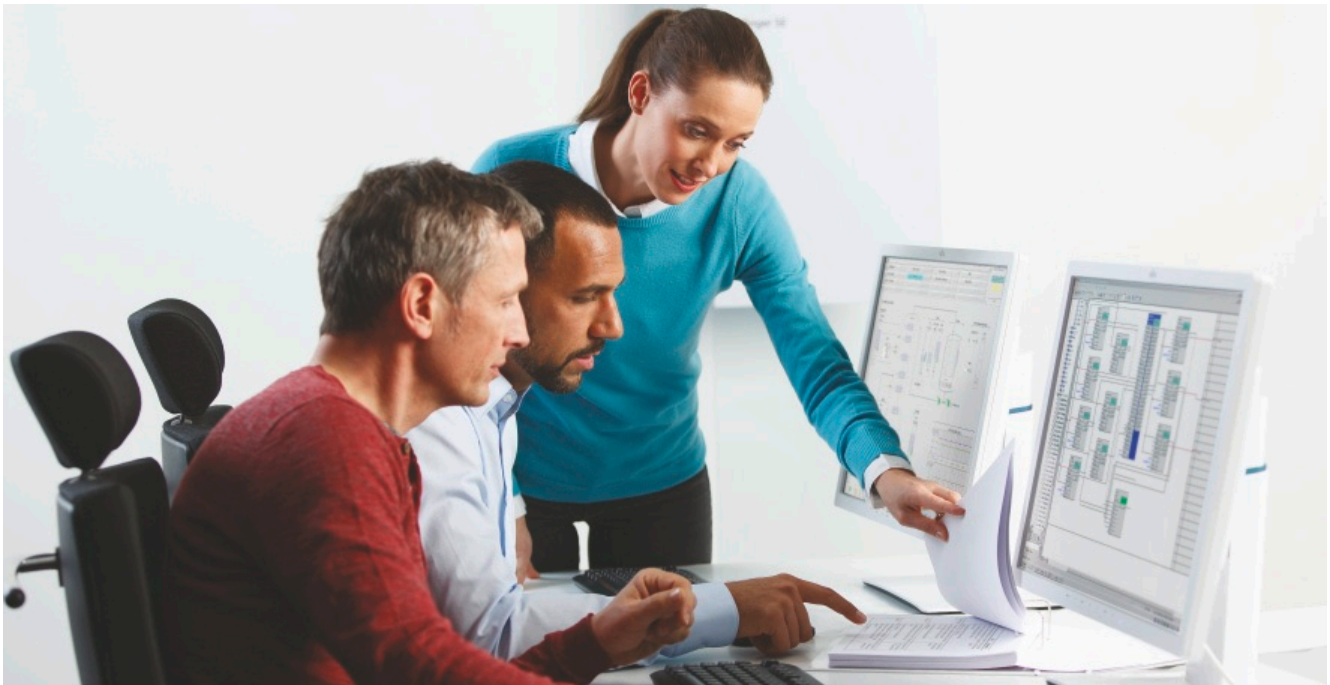

### Engineering system at a glance

- Central hardware and software configuration which is uniform throughout the system through use of one engineering system
  - Low-effort parameterization of communication
  - Same configuration for redundant plants
  - Integrated configuration for field devices and safety-related applications
- Technology-oriented configuration
  - Functional hierarchy organized according to plants, units and technical equipment
  - Hardware-independent engineering: AS assignment and I/O modules can be subsequently selected
  - Expandable on industry-specific basis using standard data exchange interfaces
- Integral user administration with access control
- Libraries with sophisticated control functions:
  - Advanced Process Library (APL)
  - Industry Library
  - Condition Monitoring Library
- Central dialog for compilation and loading of AS, OS and SIMATIC BATCH changes
- Selective compiling and downloading on the chart level
- Process object view for display and processing of all aspects of process tags/objects
  - Convenient editing in tables
  - Process library with import/export functions
  - Online mode for testing and commissioning
- Block type changes during ongoing operation with AS 410 (TCiR)
- Shared configuration tasks: Concurrent Engineering or Multiproject Engineering with Branch & Merge
- Technological engineering with control module types
  - Reduced testing effort through type-based testing
  - Faster, repeatable work through use of types
  - Reduced maintenance effort for libraries
  - Parallel working reduces the project duration
- Configuration-dependent hiding of alarms for specific operating states
- Special SFC functionalities:
  - SFC type: sequential control for multiple use, instances as block in the CFC
  - SFC: sequential control for single use, also with chart I/Os
  - Separate sequences for states such as HOLD, ABORT or SAFE STATE, conforming to ISA-88
- Lower engineering/validation overhead:
  - Libraries with functions and faceplates, icons and process tag types
  - Type-instance concept with central modification option for all instances
  - Central updating of all block types of a multiproject
  - Simple duplication of units by copying, renaming and compilation
- High-performance version management with version comparison and version history
- Automatic generation of diagnostics displays for the maintenance station on the basis of the project data

# Integrated Engineering

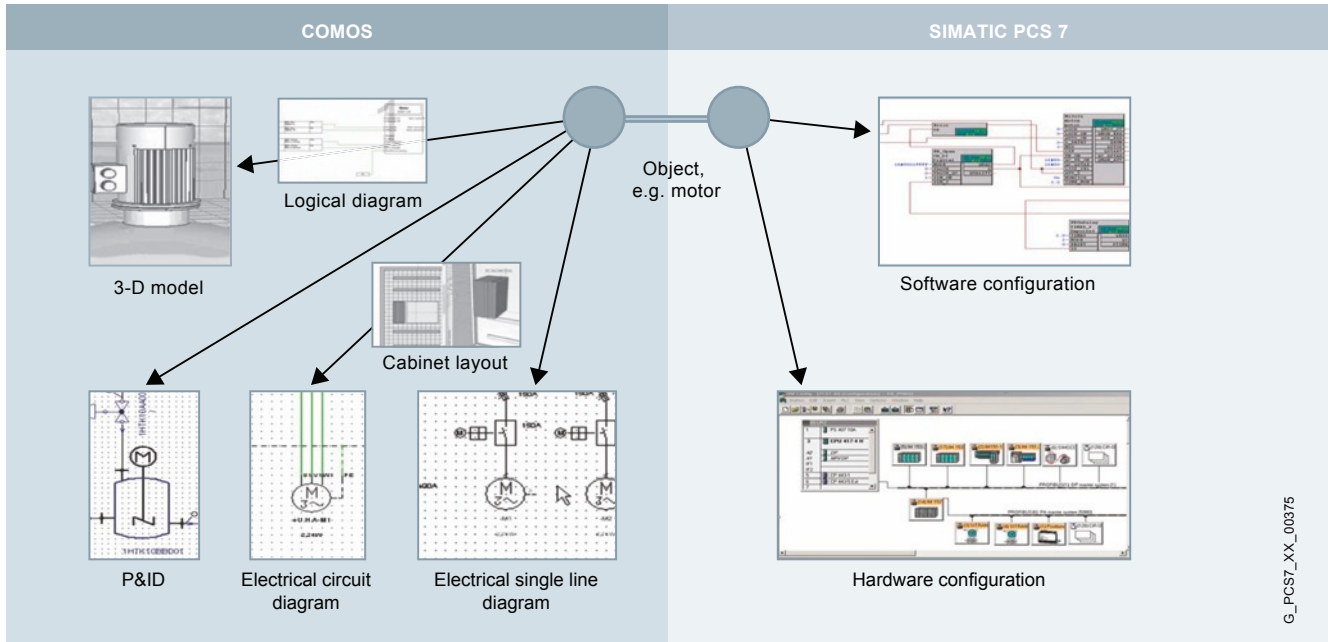

Synchronization of planning data, configurations, structures and function charts with the PAA

## COMOS – One database for everything

The basis for the Integrated Engineering is a data model in which there is exactly one instance of all engineering information of a project. In addition, all data on the engineering objects of the facilities is available directly, with consistent content and at all times, for example for the plants, pipelines, EI&C systems, instrumentation and automation engineering. It is irrelevant whether facility workers are located close together or are part of a global project team from different countries: The database is always the same – without exception.

With COMOS, Siemens is the only provider to offer the process industry a software solution for the integrated management of a plant project and the management of the entire plant documentation – from planning through operation and modernization up to decommissioning.

COMOS ensures that planners and operators can access all project-relevant data at any time, across all levels of corporate organization and all project phases. This has become possible through the consistent object orientation.

## Integrated engineering with the SIMATIC PCS 7 Plant Automation Accelerator: the bridge between the COMOS and SIMATIC PCS 7 worlds

The Plant Automation Accelerator (PAA) tool bridges the gap between plant planning and I&C from the quotation phase to the operating phase. From quotation preparation and planning to functional planning, the PAA provides a

platform with efficient, wizard-guided support for creation of the topology diagram and automatically generated bills of materials from the hardware configuration.

At the touch of a button, data such as the hardware configuration, interconnections, system structure and function charts are generated from the engineering data in the control system. This simplifies engineering of the automation and enormously reduces time overheads. The bidirectional synchronization enables changes in the automation to be restored from SIMATIC PCS 7 to PAA during operation (e.g. replacement of field devices). The database in the engineering tool is thus updated immediately, together with the complete plant documentation.

The PAA uses the full basic scope of functions of the COMOS platform with user administration, change management with working layers and scalability. The integration of the PAA as a module in COMOS provides holistic, seamless engineering across all planning phases of an industrial plant.

In this way, integrated engineering provides the requirements for more confident decision making and for more efficient processes – thus making a contribution to sustained improvements in competitiveness.

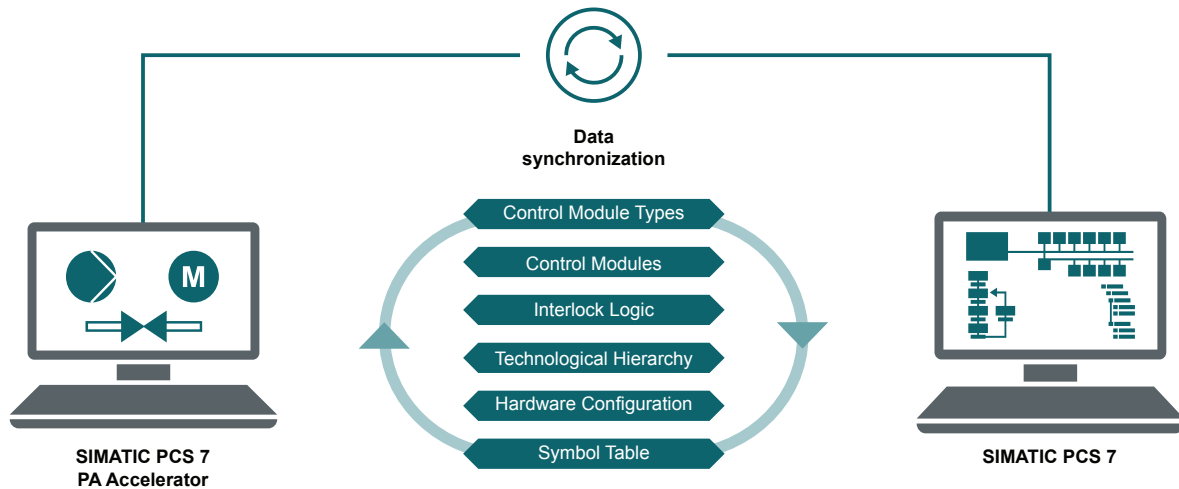

Synchronized data between SIMATIC PCS 7 PA Accelerator and SIMATIC PCS 7

### SIMATIC PCS 7 Plant Automation Accelerator (PAA)

With PAA, consulting engineers and planning offices as well as end customers can significantly reduce their configuration and commissioning costs while simultaneously improving the engineering quality.

PAA acts as a link between standard engineering tools from the SIMATIC PCS 7 Engineering Toolset (CFC, HW Config, plant hierarchy) and tools for basic and detailed planning. The open and system-neutral software tool enables an integrated workflow across all engineering phases

With its "Logical" and "EI&C" modules, PAA offers control cabinet engineering, circuit diagrams and interconnection diagrams, EMR diagrams and detailed engineering and supports the hardware layout, including bundle and rack configuration and I/O assignment.

The PAA automatically creates quotation data such as bills of materials from this planning configuration. A license overview, component overview and an article description, including the article number, are also created. For automation engineering, the control module types enable bulk processing of process tags, signals and parameters, which can be edited and changed in a controlled manner using a delta view. Process tags (control modules) can be created with any PCS 7 project library.

Inconsistencies can be detected quickly by means of plausibility and data consistency checks, displayed in a log and then eliminated in a targeted manner.

From the resulting database, the PCS 7 control system data can also be automatically generated from the planning data at the push of a button.

The planned project data is now synchronized with SIMATIC PCS 7 and then generates the PCS 7 engineering data. Changes can be made both in PCS 7 and with the PAA. The bidirectional synchronization between PAA and SIMATIC PCS 7 with delta view ensures the controlled editing of data. In this way a consistent database is ensured from the planning phase to the operating phase.

The automatically generated As-Is documentation is based on this data. During commissioning, a software test report can be automatically generated, for example. Even during plant operation, current documentation containing consistent PCS 7 and planning data is always available. PAA can be expanded up to and including the full version of COMOS. Location-independent multi-user operation is possible with corresponding licensing and management.

### Mass data engineering

Plant Automation Accelerator is optimized for working with control module types (CMT) and provides an integrated CMT library.

With system support, any user libraries with process tag types can be converted into control module types. Blocks, links, connections or messages can be added later to a CMT or removed from it, even if instances (individual control modules (CMs)) already exist. In this way, versions of process tag types can be defined very easily for multiple uses. The instances can be checked for deviations from CMT and adapted if necessary.



# Operator System

## Safe and convenient process control

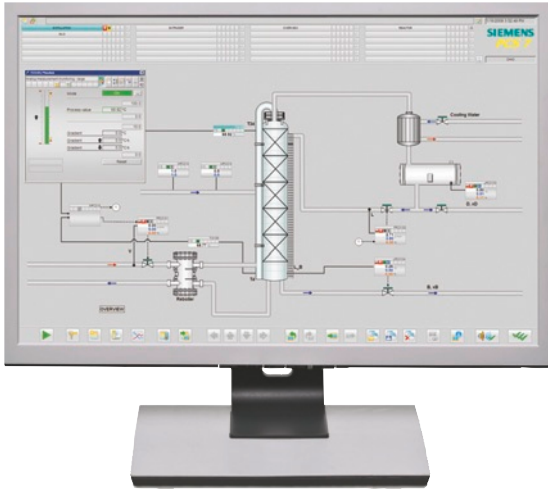

SIMATIC PCS 7 Operator Station

The operator system of the SIMATIC PCS 7 process control system permits user-friendly and secure execution of the process by the operating personnel. Operators can monitor the process sequence using various views and intervene as necessary.

The operator system architecture is extremely variable and can be flexibly adapted to different plant configuration limits and customer requirements.

- Single-station system (OS single station) with up to 8 500 process objects
- Flat system configurations based on a redundant OS single station pair, expandable with reference stations to up to 8 OS single stations.
- Client/server multiple station systems with up to 18 OS servers/pairs of servers, each for 12 000 process objects and up to 40 OS clients

### Operator stations

All operator stations are based on modern, high-performance SIMATIC PCS 7 Industrial Workstations optimized for use as OS single station, OS server or OS client. They can operate in harsh industrial environments and offer numerous standardized interfaces for options specific to the system, customer or sector as well as expansions.

In multi-monitor mode with up to 4 process monitors, the operator can run several plant areas from a single workplace.

### Single-station system (OS single station)

In a single-user system architecture, all operator control and monitoring functions for a complete project (plant/unit) are concentrated in one station. A flat system configuration with up to 8 OS single stations can be implemented. In this case, two stations form a redundant pair of OS single stations that can be further expanded. With such a configuration, the engineering can be rationalized by duplication of a basic project. The Process Historian is used for long-term archiving.

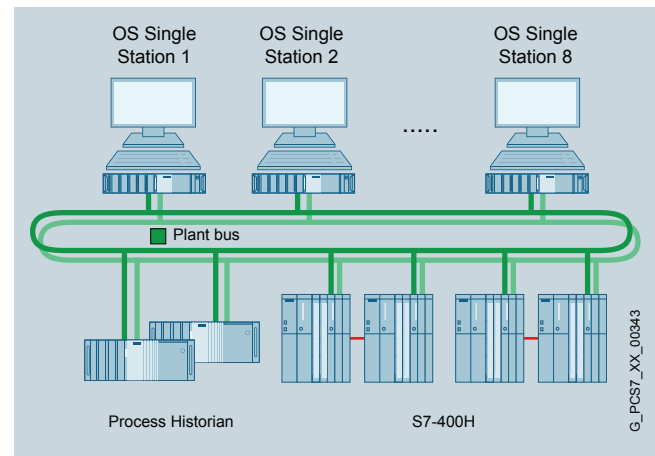

Example of a flat system architecture

The OS single station can be connected to the Industrial Ethernet plant bus in two ways:

- CP 1623/CP 1628 communication module for communication with a maximum of 64 automation systems of any type
- Simple 10/100/1000 Mbps Ethernet network card and Basic Communication Ethernet for communication with up to 8 automation systems (single stations)

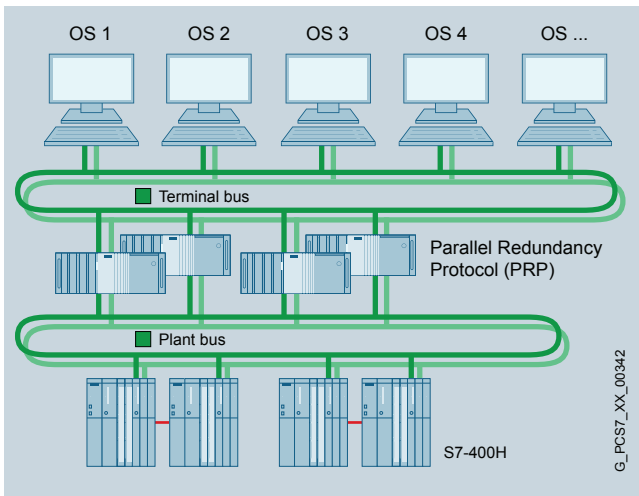

System architecture with redundant terminal and plant buses

### Multiple-station system with client/server architecture

With a multiple-station system, one or more OS Servers supply up to 40 operator stations (OS clients) with data (project data, process values, archives and messages) via a terminal bus. The terminal bus can share the transmission medium with the plant bus or it can be designed as a separate bus (Ethernet with TCP/IP).

In this architecture, redundant OS servers may be set up to meet higher availability requirements. The OS clients can access the data of not only one OS server/server pair, but from several simultaneously (multi-client mode). This makes it possible to divide a plant technologically and to distribute the units to several OS servers/server pairs.

In addition to scalability, the advantage of distributed systems is the ability to decouple plant areas from each other, which results in higher availability.

SIMATIC PCS 7 supports multiple station systems with up to 18 servers or 18 redundant pairs of servers. In multi-client mode, OS clients can access data from one or more of the 18 servers/pairs of servers in parallel (up to 40 OS clients simultaneously can access all).

The OS servers are designed in addition with client functions that enable access the data (archives, messages, tags, variables) from the other OS servers of the multiple-station system. For area-spanning pictures, the process pictures on one OS server can also be linked to variables on other OS servers.

### Operator system, quantity structure

Max. number of OS single stations	8
Max. number of OS servers/pairs of servers	18
Max. number of automation systems per OS server/pair of servers	64
Max. number of OS clients in multi-client mode <sup>1)</sup> , per multiple station system	40
Max. number of monitors per operator station with multi-channel operation	4
Max. number of OS areas	64
Max. number of windows per monitor	1 to 16 (adjustable)
Number of trends per trend window	10
Selection time for OS area display (100 process symbols)	< 2 s
Max. number of configurable messages per server	200 000
Max. number of configurable process objects	Approx. 216 000
Max. number of configurable process tags	Approx. 128 000 <sup>2)</sup>
Integral high-performance archive system (circular buffer), based on Microsoft SQL server, for:	
<ul style="list-style-type: none"> <li>Process value archiving (per OS server/single station)</li> </ul>	Approx. 1 500/s
<ul style="list-style-type: none"> <li>Alarm logging (per OS server/single station)</li> </ul>	Permanent load approx. 10/s Message burst approx. 3 000/4 s

<sup>1)</sup> If every OS client has access to all OS servers/pairs of servers

<sup>2)</sup> Approx. 300 000 I/O

### Performance

The SIMATIC PCS 7 Operator System is optimized for processing large quantities of data. It impresses by means of its simple and intuitive operation and its high performance – even with large quantity frameworks. Many individual measures reduce the system load and improve the picture selection and updating times, e.g.:

- Combination of status and analog values with alarm information into expanded status displays
- Suppression of nuisance alarms and triggering of renewed transmission via acknowledgment
- Data transmission from the automation system based on change instead of cycles
- Blocking/enabling of messages for individual process tags or all tags of an area
- Hiding messages, depending on the operating state of the unit

# OS software



Innovative process visualization with PCS 7 Advanced Process Graphics

## Graphical User Interface (GUI)

The predefined GUI of the operator system has all the features typical of a control system. It is clearly structured, ergonomic, easy to understand and multilingual. Operators can survey the process extremely easily and rapidly navigate between different views of the plant. The system supports them in this process with hierarchical display structures that can be configured as required. These facilitate the direct selection of lower-level areas during process control. The current position within the hierarchy can always be seen in a window of the Picture Tree Manager.

Mimic diagrams and process tags can also be called directly by their name or by a "Loop-in-alarm" starting from a selected message. An online language selector permits the user to change the display language during runtime.

Depending on the design of graphics controller and process monitor and their resulting configuration, the process pictures can be displayed in standard and wide-screen formats with resolutions up to 2560 × 1600. A standard view and a server view with a variety of designed area overviews are available for the technological visualization of a system. Both include these features:

- Message line for the last received message, configurable for priority-based display of message with highest message class or priority
- Date, time and name of the operator
- Area overview; with 36-144 displayable areas depending on the resolution
- Working area for plant displays and movable windows for faceplates, trends, messages etc.
- Key area, customized configuration

Based on this, the operator can combine and save individual picture compositions and recall them later.

The global appearance can be set using predefined or user-specific designs (color palette, colors, styles, optical effects, etc.). These central design settings can be changed locally for each picture object. In addition, the design can be fundamentally influenced using a wide range of attractive elements provided in the Engineering System for OS configuration:

- Object palettes with styles, controls, standard objects and smart objects
- Global symbol library with standardized display objects
- Symbols and faceplates of the PCS 7 Advanced Process Library (APL)

Graphics objects of the PCS 7 Advanced Process Graphics (APG) adapted to the APL enable task-specific optimization of process visualization with overview pictures (level 1/2). Compact, simplified representations draw attention to the essentials. This helps the operator to quickly grasp the current plant situation, identify trends early on and react immediately.

## Process tag browser

The SIMATIC PCS 7 process tag browser enables the display, filtering and sorting of status information from APL-based monitoring stations. The operator can thus identify and quickly select process tags with a particular status. The faceplates can be selected directly based on the status of selected process tags per loop-in function.

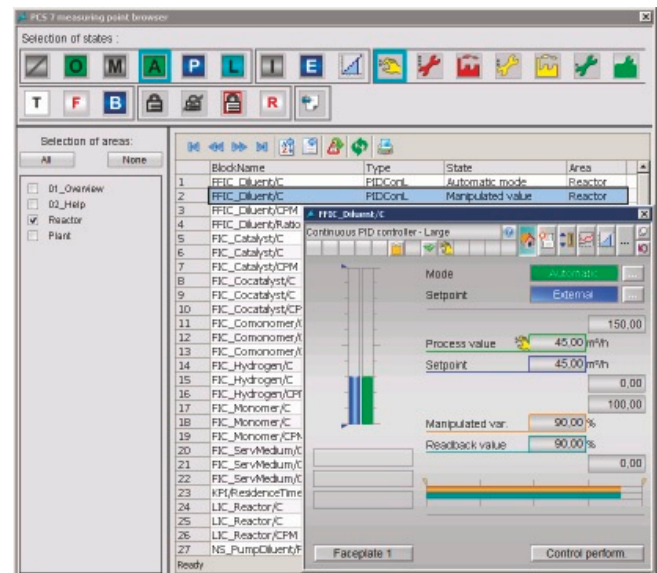

Easy operator control with the process tag browser



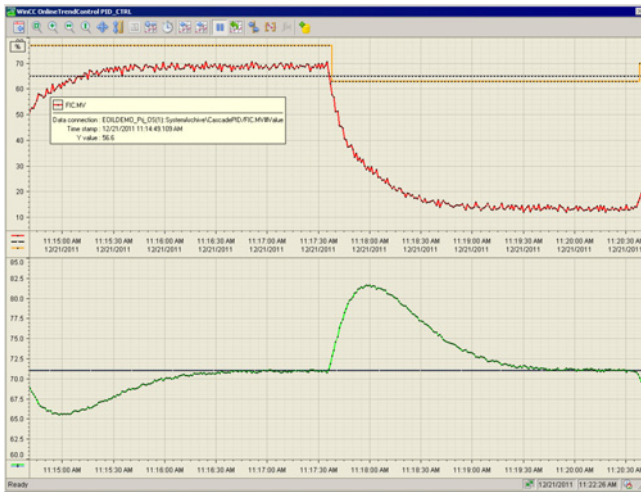

Trend window on the operator station

### Trend controls for displaying tables and trends

Using Trend Controls, operators can show archived values of archive tags from the process value archive as well as online values of process tags from the tag management in relation to time (table/trend window) or in relation to another value (function window).

During runtime, operators can individually adapt the TrendControls functions which have already been predefined during plant configuration and save the settings globally or user-specific. They are able to change the data link during runtime, and to access other data, and integrate exported archive databases.

In the ruler window, additional information can be displayed for the time or time range selected in the trend/table window with a ruler, for example, statistical information such as minimum, maximum, average, standard deviation, integral.

### APL operator trend control

The APL Operator Trend Control can also be used for flexible online compilation of trend displays with values of APL-based process tags. The operator can select the values for the trend display with a simple mouse click. Value range and unit are adopted automatically by the process tag. The selection can be subsequently adjusted by adding and removing values. Messages can be called according to the trend selection.

### Message list for message display and processing

Up to 200 000 messages can be configured per OS single station/OS server:

- Predefined system messages, triggered by a system event
- Individual or group messages, initiated by a change in process states
- Operator input messages, resulting from the manual operation of objects

The message system integrated in the operator system records these process messages and local events, saves them in message archives, and displays them using the freely-configurable message list:

unacknowledged messages; acknowledged messages; unacknowledged but already gone out, operator messages, process control messages, old message list, messages to be hidden, hidden messages.

Parallel to the display, all messages recorded during runtime and their changes in state can be documented in chronological order in a message sequence log.

By filtering, selecting or sorting the display according to the contents of individual message blocks, e.g. chronologically according to message priority or fault location, the operator can individually adapt the message list during runtime. It is also possible to integrate archive databases online. The settings can be saved globally or user-specific.

To reconstruct the state of the messages after a power failure, the most recent messages from the message archive can be loaded back into the message window.

Message view of operator station

In the case of large quantity structures with a high volume of messages, the following measures can improve transparency and perceptibly offload the operating personnel:

- Situation-based hiding of messages that are not needed based on current operating states (with complete logging and archiving):
  - Dynamically, depending on preconfigured definition for up to 32 operating states (Smart Alarm Hiding)
  - Manually, for a limited period
- Assignment of priorities using up to 16 message priorities as additional attribute to the message/alarm classes
- Intentional blocking/enabling of messages from an individual process tag or all process tags of the display/area, e.g. in the event of faults on a sensor/actuator or during commissioning (recorded in operator activity log)

For fast identification of faults and their resolution, the operator can go directly from the selected message goes to the process picture with the problematic object (loop in alarm). There, the operator can use the color-coded process tag to open the associated faceplate (loop). The faceplate window can be anchored so that it remains visible even when the display is changed.

Group displays visually signal the messages currently present in the mimic diagram. They do not provide information on whether messages are disabled or not.

The last received message is displayed at the top of the standard view. Using the "Extended message line" button, the Alarm Control function can be displayed as a window with all received messages. A list of all messages currently present with maximum priority can also be directly called using a button.

### Reporting and logging system

Whereas the reporting system is provided to document the project during configuration, the logging system is used to print out the data recorded during operation in a clear manner. Different types of predefined logs are available:

- Message sequence log
- Message and archive log
- Measured value log
- Operator activity log
- System message log
- User log

However, a page layout editor can be used to create completely new page layouts or to individually adapt predefined ones. Log objects to be printed are simply selected from the editor's object palette, positioned and configured.

### Archiving

The OS single stations and OS servers have an integrated, high-performance archiving system which can be configured during runtime. It stores process values and events temporarily in short-term archives. Data can be transferred from this historical alarm list to the Process Historian for long-term archiving on a time-driven or event-driven basis.

### Central user administration and access control

The administrator can use SIMATIC Logon to divide the users into groups and assign differently defined access rights (roles) to these groups. The operator obtains these specific rights when logging on. In addition to a keyboard, an optional smart card reader, for example, can be used as a logon device.

SIMATIC Logon supports both one-factor authentication and two-factor authentication using a smart card.

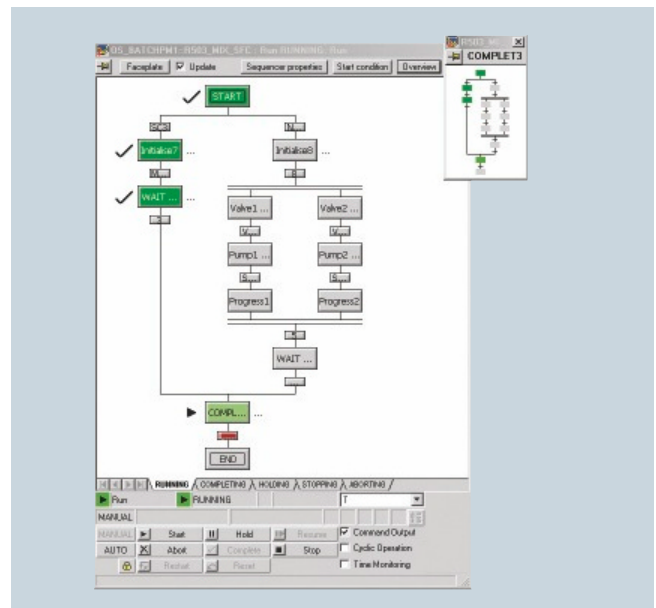

SFC Visualization

### SFC Visualization

SFC visualization of the operator system allows sequential control systems configured with the SFC editor to be represented and operated in the same way as on the engineering system. This does not involve any extra configuration effort. In an overview display it is possible, for example, to open step and transition displays and to present step comments or dynamically supplied step enabling conditions.

### Time synchronization

Together with a SICLOCK time generator, the operator system within SIMATIC PCS 7 can implement system-wide time synchronization. This feature is especially beneficial for widely distributed plants present in different time zones, e.g. pipelines.

# Operating control and monitoring via Internet/intranet

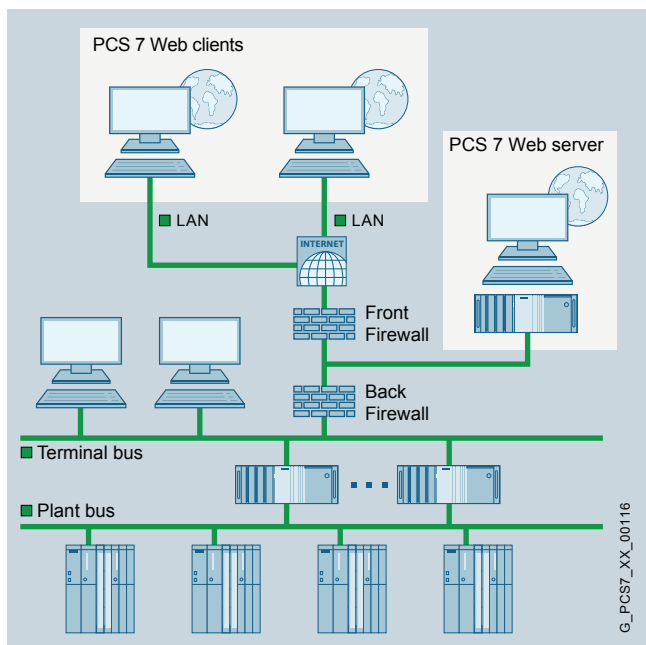

PCS 7 Web Server for operator control and monitoring via Internet/intranet

## Process control via PCS 7 Web Server

SIMATIC PCS 7 systems can be operated and monitored via Internet/intranet. In this case, the operator uses the PCS 7 Web client to access the project data provided by the PCS 7 Web server. The PCS 7 Web server uses the mechanisms of a multi-client for the interaction with the lower-level OS servers. The integrated OS user management thus guarantees a high degree of security.

A plant can be operated and monitored via PCS 7 Web client in the same manner as with the PCS 7 OS client. SFC Visualization is supported in addition to the standard OS functions. The operator has the same rights and access control is identical. The input operations made on the PCS 7 web client are recorded in the OS operating log.

All Web publishing contents of a SIMATIC PCS 7 project can be defined and managed in a central configuration dialog. This provides customized, project-specific setting options for each PCS 7 Web server. The configuration created with this dialog can be immediately published or stored for later use. Trend displays can also be configured online.



## Mobile terminals with WinCC/WebUX

Based on WinCC/WebUX, authorized personnel access online information of the SIMATIC PCS 7 with any mobile devices, such as smart phones or tablets, via Internet/intranet and takes action, if needed. The operating system of the mobile terminal is irrelevant. The only requirement is that the browser of your choice supports the latest Web standards, SSL, HTML5 and SVG.

Possible applications include:

- Visualization of key performance indicators (KPIs)
- Presentation and evaluation of process information (values and trends)
- Display of service information, messages and their acknowledgment



## Operator system at a glance

- Flexible, modular architecture with scalable hardware and software components for single-user and multiple station systems
- Client-server multiple station systems, suitable for large plants with up to 18 OS servers / server pairs and up to 40 OS clients
- High-performance, stress-resistant operator stations based on rugged industrial standard PC technology
- OS single stations and OS servers that can be configured as redundant pairs
- Optimized AS/OS communication
- Copying of modifications without interfering with ongoing operations
- Online test of changes by selective loading of redundant servers
- Ergonomic graphical user interface for convenient process control and high reliability
- Browser for stateful view, filters and sorting of APL-based process tag
- Versatile, practical controls for alarms and trends
- Flexible online configuration of trend displays with values of APL-based process tags
- Variable, customer-oriented logging system
- Highly effective alarm management provides support for operating personnel
  - Assignment of priorities with up to 16 message priorities as additional attribute to the message classes
  - Visual and audible hiding of messages which are irrelevant depending on the operating state (dynamic or manual)
  - Suppression of sensor/actuator alarms during startup or in event of malfunction
- High-performance archiving system with circular archives and integral archive backup, which can be combined with the Process Historian for long-term archiving
- Central user administration with access control
- System-wide time synchronization



# Process Data Archiving and Reporting

## Process Historian and Information Server



### Process Historian

The Process Historian is a high-performance system for long-term archiving, which integrates perfectly into SIMATIC PCS 7. Process data, tags, alarms, as well as batch data of the control system can be centrally archived in real time without additional engineering overhead. The number of archivable single stations, servers or server pairs is unrestricted. The Process Historian is suitable for all plant scales.

The process values and alarms managed in the database of the Process Historian on the OS clients and OS single stations can be visualized in a user-friendly and clear manner. Data selection is supported by integrated filter functions. Alarms and process values can be shown in table form and process values also in graphic form. Tables of process values can be exported in CSV format for processing in other Windows applications, e.g. Microsoft Excel.

Data managed by the Process Historian can be backed up on external storage media, such as an NAS drive. You also can back up and restore the complete database both manually and automatically.

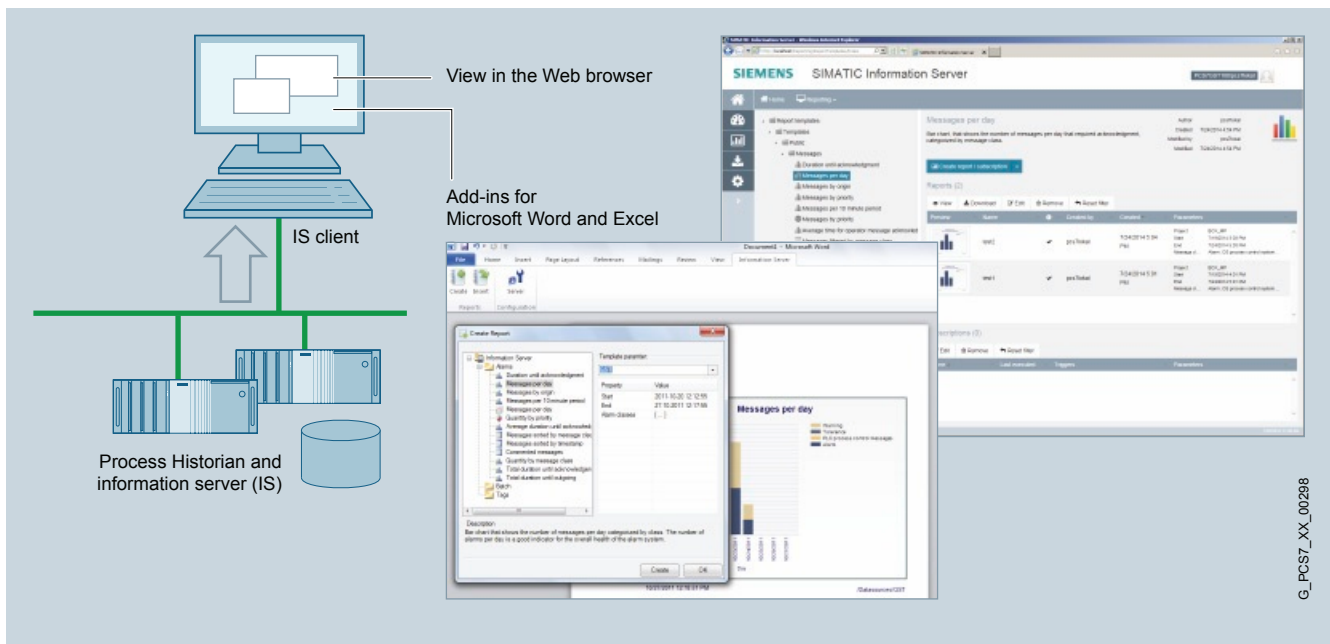

Methods of accessing the Process Historian data stock

G\_PCS7\_XX\_00298

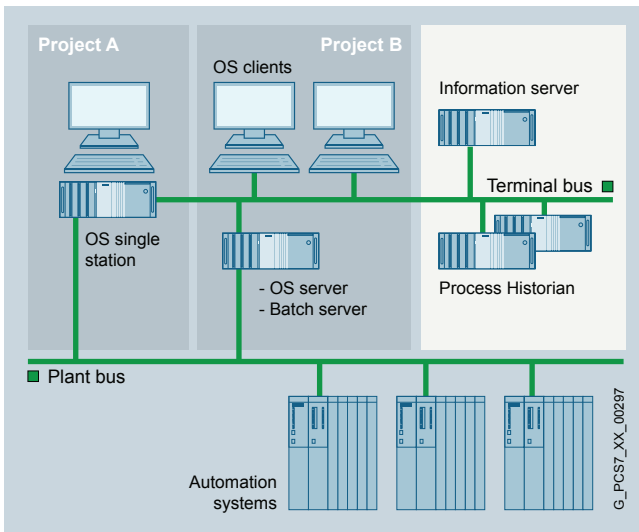

### Information server

Visualization of the data from the Process Historian database is supported by an additive reporting system, the Information Server. It provides the archived data in a Web browser in the form of shift, daily, weekly or monthly logs. Based on the Microsoft Reporting Services, the Information Server enables Web-based thin-clients to access to historical data. Add-ins for Microsoft Word und Excel offer additional methods of accessing the Process Historian database. The number of clients that have access to the Information Server can be regulated with cumulative client access licenses.

The Information Server is able to access one data source or multiple data sources in parallel. In addition to the Process Historian, this might also include archive data from operator stations. It can therefore also be used for plant reporting independent of the Process Historian.

If the Process Historian OPC UA Server is installed on the Process Historian, other applications can act as OPC UA clients and read the process values and messages archived in the Process Historian.

### Hardware and configuration

Depending on how important the availability of archive data is for the plant operator, the Process Historian can be configured either as a single server or a redundant pair of servers. For optimal, project-specific layout of the computer hardware for the Process Historian, please use the PH Hardware Advisor, available at <https://support.industry.siemens.com/cs/ww/en/view/109740115>

The Information Server can be operated on the Process Historian hardware or on separate hardware. Any OS server version of the SIMATIC PCS 7 Industrial Workstation is suitable for separate operation.

The Process Historian and Information Server do not need a connection to the plant bus. They can be connected to the OS and batch stations of the SIMATIC PCS 7 system via the terminal bus.

### Archiving and visualization functions

- Real-time archiving of the process values and messages of OS single stations und OS servers
- Archiving the batch data of SIMATIC BATCH
- Support of multiple SIMATIC PCS 7 projects
- Scaling of performance and configuration limits for the basic hardware employed
- Data export to external storage media, e.g. a NAS drive
- Data import from external storage media
- Data visualization on the OS clients / OS single stations:
  - Configuration of views (picture windows and masks) including the selection criteria for displaying the data
  - Visualizing of messages in table form dependent on filter functions
  - Display of process values in table or graphic form depending on filter functions
  - Batch overview (with a detailed log of a batch)

### Reporting functions

- Set of conventional report templates for process values, alarms and batches
- Free creation of any number of new report templates
- Storage of configured report templates for fast access
- Report export in common document formats
- Subscriptions for cyclic report generation including e-mail service
- Creation and storage of role-based dashboards
- Role management for Windows users
  - Support for Active Directory and workgroups
  - Project-specific assignment of access permissions
- Integration of reports as pictures into Word documents
- Creation and storage of Excel report templates for historic process values and alarms
- Subscriptions for Excel report templates

For additional information, see:  
[www.siemens.com/simatic-pcs7/processhistorian](http://www.siemens.com/simatic-pcs7/processhistorian)



# Plant Device Management

## Engineering intelligent field devices with SIMATIC PDM



SIMATIC PDM (Process Device Manager) is an universal, multi-vendor tool for configuration, parameterization, commissioning, diagnostics and servicing of intelligent field devices (sensors and actuators) and field components (remote I/Os, multiplexers, control room devices, compact controllers). It enables the handling of more than 3 500 devices from Siemens and over 200 vendors worldwide on one homogeneous GUI.

From the viewpoint of device integration, SIMATIC PDM is the most powerful open device manager available in the world. Devices which previously were not supported can be integrated in SIMATIC PDM by importing their device description files (Electronic Device Description, DD/EDD technology) or device description packages (Field Device Integration, FDI technology).

### Advantages with operational processes

- Uniform presentation and operation of devices
- Uniform representation of diagnostic information
- Indicators for preventive maintenance and servicing
- Detection of changes in the project and device
- Increasing the operational reliability
- Reducing the investment, operating and maintenance costs
- Forwarding of device information to higher-level maintenance stations

Plant-wide access to the field devices with secure server-client communications, significantly reduces the service and traveling times of the service personnel:

- Field device configuration on stationary and mobile workstations with standard browsers
- Connection of up to 30 clients to a SIMATIC PDM server without installing additional software

### Variety of application options

- Single point station for handling a single field device
- Local service and configuration station for handling multiple field devices on the fieldbus segment or remote I/O station
- HART service and parameter assignment station for processing HART field devices
- Central service and configuration station for processing field devices of a production plant
- Configuration tool in the engineering station for handling field devices in the hardware configuration editor of the engineering station or locally at the field device via a mobile SIMATIC PDM client
- Configuration and service tool in the SIMATIC PCS 7 Maintenance Station for field device handling via the operator stations of the maintenance station or via a mobile SIMATIC PDM client locally on the field device

For additional information on SIMATIC PDM, see:  
[www.siemens.com/simatic-pcs7/pdm](http://www.siemens.com/simatic-pcs7/pdm)



## Device integration

SIMATIC PDM supports all devices defined by the Electronic Device Description (EDD). At the same time, it is the guideline of the established organizations, such as:

- PROFIBUS & PROFINET International (PI)
- FieldComm Group (FCG)

The devices are integrated directly in SIMATIC PDM through a company-specific EDD or the current libraries of the FieldComm Group. To achieve improved transparency, they can be managed in project-specific device libraries. The range of devices can be updated and expanded at any time by importing the device description of the manufacturer.

## Core functions

- Creation of project-specific device libraries
- Adjustment and modification of device parameters
- Comparing, e.g. project and device data
- Validation of data input
- Device identification and testing
- Device status indication (operating modes, alarms, states)
- Simulation
- Diagnostics (standard, detail)
- Management, e.g. networks and computers
- Export/import (parameter data, logs, documents)
- Commissioning functions, e.g. measuring circuit tests of device data
- Lifecycle management functions, e.g. for device replacement
- Global and device-specific change log for user operations (audit trail)
- Device-specific calibration reports
- Graphic presentations of echo envelope trends, trend displays, valve diagnostics results etc.
- Display of incorporated manuals
- Bulk operations

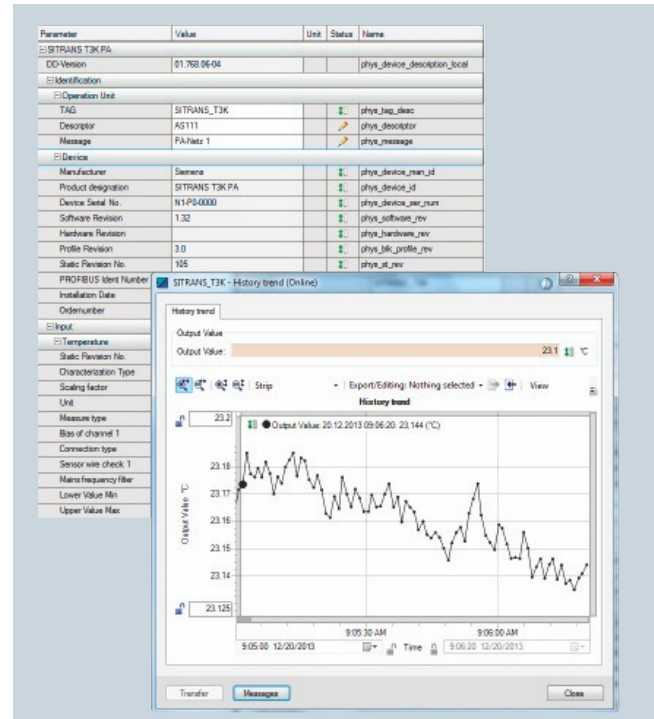

SIMATIC PDM, parameter view and trend window

## Communication and routing

SIMATIC PDM supports several communication protocols and components for communicating with devices that have the following interfaces (others on request):

- PROFIBUS DP/PA interface
- FOUNDATION Fieldbus (FF) interface
- PROFINET interface
- HART interface (modem, wireless)
- Modbus interface
- HART over PROFIBUS/PROFINET

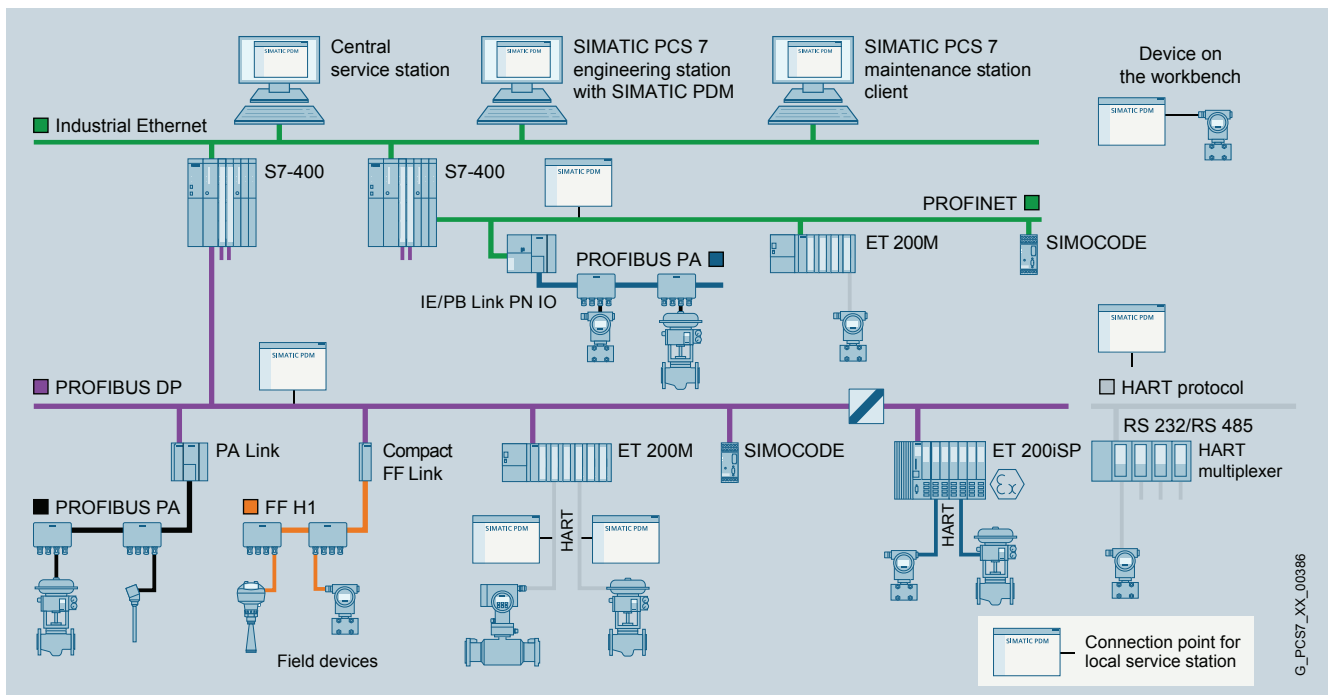

Possible connections of SIMATIC PDM

# Plant Asset Management with the SIMATIC PDM Maintenance Station



SIMATIC PDM Maintenance Station, consisting of preinstalled SIMATIC IPC 427E Microbox PC as well as software and function licenses

Failure of a temperature, flow or pressure sensor can quickly lead to a plant malfunction. SIMATIC PDM Maintenance Station (SIMATIC PDM MS) offers the right solution to efficiently monitor the condition of smart field devices independent of the automation and control system used.

## Uniform presentation of messages

The maintenance station is designed for small to medium-sized projects (up to 500 field devices). In large plants the station can be used multiple times based on plant units or field device groups. All field devices that are integrated into the device description library of SIMATIC PDM can be monitored. They are integrated using device description files (DD/EDD technology) or device description packages (FDI technology). SIMATIC PDM MS supports a wide range of communication types and gateways between bus systems such as Ethernet, PROFINET, PROFIBUS DP/PA and HART. The integrated SIMATIC PDM is used for parameter assignment and detailed diagnostics of the field devices.

System functions of SIMATIC PDM MS can be used for any field device, regardless of manufacturer and type. Users can solve a wide range of tasks with such a station:

- Overviews of device states
- Creation of overview and work progress lists
- Representation of overview, segment and detail screens
- Condition reports
- Global and device-specific alarm lists
- Archiving of parameter data
- Connection of mailing/paging systems
- Synchronization of parameter data

## Easy engineering

Engineering of the SIMATIC PDM MS is easy and requires minimal effort. Network structures and field devices can be easily taken over from existing projects. If required, the quantity structure of SIMATIC PDM MS can be adapted to the field devices to be monitored and expanded to include the server/client functionality of SIMATIC PDM.

### SIMATIC PDM MS at a glance

- SIMATIC PDM MS allows cyclic data transfer to cloud-based systems, enterprise management systems or XHQ for analysis and further processing of field device data.
- The stand-alone maintenance station can be used independent of automation systems and their version.
- Easy and familiar operation of SIMATIC PDM MS as a product of the SIMATIC PCS 7 product family

### SIMATIC IPC 427E Microbox PC

The fanless embedded Microbox PC can be used for complex control tasks, visualization solutions and production-related data acquisition and analysis. It can be flexibly configured, is maintenance-free and allows fast data processing. Find out more at [www.siemens.com/ipc427e](http://www.siemens.com/ipc427e)

Additional information on SIMATIC PDM can be found at: [www.siemens.com/simatic-pdms](http://www.siemens.com/simatic-pdms)

# Plant Asset Management with the SIMATIC PCS 7 Maintenance Station



The SIMATIC PCS 7 Maintenance Station is used to manage a company's assets that are used for production. It is dedicated to the "Plant Asset Management", in other words, the efficient administration and management of the equipment of a technological plant, especially instrumentation and control systems, with the goal of value preservation and appreciation. It thus makes a valuable contribution to minimizing the total cost of ownership of a plant over its entire life cycle.

While the plant operator obtains all relevant information that is necessary for focused intervention in a process via the operator system, maintenance and service personnel can check the hardware components of the automation system (assets) and process their diagnostic messages and maintenance requests using the maintenance station. For this the maintenance station offers access to:

- Components of the process control system: intelligent field devices and I/O modules, fieldbus, controller, network components and plant bus, as well as servers and clients of the operator systems.
- Mechanical assets (pumps, motors, centrifuges, heat exchangers etc.) or control circuits represented by proxy objects in which the diagnostics rules are stored

Plant operators and service personnel are able to constantly react to the following, for example:

- Service requests
- Service approvals
- Placing an asset in "In Service" status
- Information regarding completed servicing

All activities are documented on the maintenance station without gaps – automatically and without additional configuration overhead.

## Typical maintenance cycle

- Monitoring the status of components/devices:
  - Recording of diagnostics information of network components and PC basic devices per OPC coupling
  - Intelligent sensors detect and signal impending failures long before the actual failure
- Signal "maintenance required" in a group display, in symbol displays of the affected components/devices and in an alarm log
- Select component/device with maintenance requirement and retrieve specific data, for example, the process tag number, installation location, device type
- Retrieve device and manufacturer-specific detailed diagnostics information, for example,
  - Error description
  - Cause of error
  - Trend statement
  - Handling instruction
- Evaluation, commenting and changing the priority of the maintenance requirement when needed
- Initiate maintenance measure per maintenance request and track progress; current status of maintenance is visualized symbolically
- Conclusion of maintenance measure; all status displays are reset to their normal state

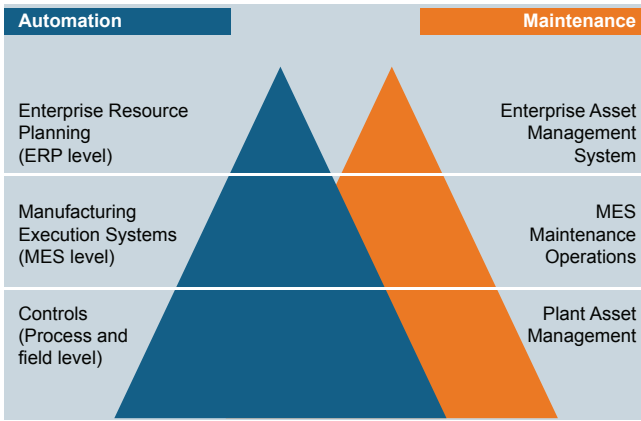

Plant automation and maintenance in process engineering

### Architecture

The SIMATIC PCS 7 Maintenance Station (MS) conforms to international standards, specifications and recommendations. It is based on the NAMUR<sup>1)</sup> requirements defined for systems for plant-floor asset management and status messages from field devices. For asset management, it uses hardware and software components of the engineering system (ES) and Operator System (OS). As a result of the close interlacing, ES, OS and asset management functions run on common hardware. Such a multi-functional station cannot only be used for asset management, but also for system engineering or HMI.

Depending on the project-specific SIMATIC PCS 7 architecture, the SIMATIC PCS 7 Maintenance Station can be implemented on the basis of a SIMATIC PCS 7 BOX, a SIMATIC PCS 7 single station or a SIMATIC PCS 7 client-server combination. In client-server combinations, the MS server can also have a redundant design.

Integrated SIMATIC PDM provides the SIMATIC PCS 7 Maintenance Station the parameter data and the diagnostic information of the devices described by the Electronic Device Description (EDD) for the display and further processing.

The access to the devices/components is controlled by function rights that correspond to the role of the user. User management and access control for the SIMATIC PCS 7 Maintenance Station is handled by SIMATIC Logon integrated in SIMATIC PCS 7.

The diagnostic screens structured according to the plant hierarchy with the operating states of the SIMATIC PCS 7 components and the diagnostic information determined by SIMATIC PDM can be displayed on pure MS clients and on combined MS/OS clients. Extended online diagnostics are available on stations with combined "MS client" and "SIMATIC PCS 7 engineering" functionality.

### Configuration

Supported by the system, the data relevant for asset management are derived from the hardware and software project of the application created with the default configuration and diagnostic screens are generated. The procedure is simple and no additional overhead is required for configuration of the asset management:

- Generation of the hardware and software project of the application
- Configuring/parameter assignment of specific maintenance station functions and connections (optional)
- System-supported generation of the diagnostics screens with all components present in the project, including the picture hierarchy based on the project's hardware structure
- Compilation of the configuration data and downloading to the operator station and maintenance station with subsequent test and commissioning phase

<sup>1)</sup> NAMUR: Process Control Standards Committee in the Chemical and Pharmaceutical Industries



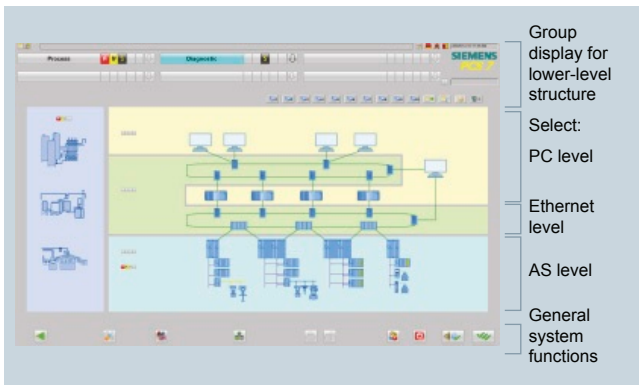

Plant overview with symbol displays for components

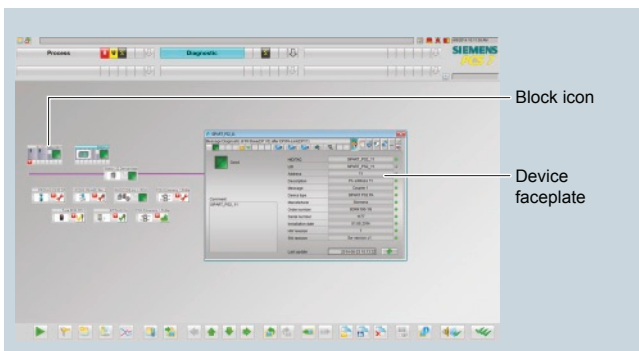

Overview of components on a PROFIBUS segment with symbol displays

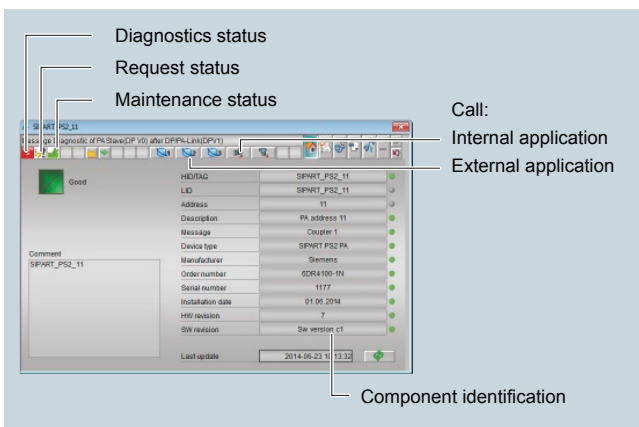

ID view of component

As the system interface to the maintenance engineer, the SIMATIC PCS 7 Maintenance Station provides integrated maintenance functions and information.

### Standard diagnostics functions

Starting from the overview display, maintenance engineers can navigate to the diagnostics displays of the subordinate hardware levels to obtain information on the diagnostics status of individual plant areas or components.

If a fault is signaled in the overview display, the "Loop in alarm" function permits rapid switching to the diagnostics faceplate of the associated component. The information available is filtered according to the role of the user, for example:

- Diagnostics status determined by the system
- Information on the component, such as process tag name, manufacturer or serial number
- Diagnostics messages of a component
- Detailed diagnostic information of a component
- Enabling of maintenance measure by the process operator
- Type and current status of initiated maintenance measure

### Information on mechanical assets

A function block acting as a proxy for mechanical assets without self-diagnostics (pumps, motors, etc.) can determine impermissible operating states from different measured values and their deviations from a defined normal status. These are then trigger a maintenance alarm. This function block is also suitable for implementing individual diagnostics structures, project-specific diagnostics rules and condition monitoring functions.

In addition, individual asset management blocks are available with which maintenance engineers can monitor plant components such as pumps, heat exchangers or control valves.

### Extended information for assets according to IEC 61804-2

Additional information can be called for assets described by the electronic device description (EDD) according to IEC 61804-2. This information is automatically read out of the components and made available by SIMATIC PDM in the background, for example:

- Device type information (electronic rating plate)
- Detailed diagnostics information
  - Device-specific information from the vendor
  - Information on fault diagnostics and troubleshooting
  - Additional documentation
- Results of internal condition monitoring functions
- Status information (local operation, local configuration changes, etc.)
- Change information (Audit Trail)
- Parameter information

### Visualization of the maintenance information

Message system, GUI, picture hierarchy and operator prompting are oriented according to the HMI philosophy of the operator system. The diagnostics data of all assets are displayed on uniform faceplates whose functions and information depend on the components. This makes working with the SIMATIC PCS 7 Maintenance Station easy and intuitive. A time-consuming training period is not required.

The hierarchical structuring of information and the uniform symbols support the overview, facilitate orientation and permit the maintenance engineer to rapidly access detailed information starting from the plant overview. Group displays in the plant overview visualize the diagnostics status of the subordinate structures/components according to a type of traffic light with red, yellow or green.

Diagnostics screens represent the status of components and subordinate devices/components through standardized symbols. Clicking an element in the symbol display either opens the subordinate hierarchy level or a component faceplate. The component faceplate offers various views of the associated component with additional device-specific information, e.g. an identification, message or maintenance view.

### Information management

The maintenance engineer can use the following functions to acquire classified information quickly and simply, access project-specific information databases or request maintenance measures:

- Cyclic functionalities
- Change configuration acquisition with data synchronization
- Creation of overviews for components of the control system and connected field devices using filter criteria based on the diagnostic status and device information (identity data export)
- Generation of reports for individual devices with all relevant information of a component to defined destinations, for example, the mail system, printer or pager (single export)
- Parameter assignment of up to three cycles with selected filter settings, each for export of identity data or parameter data in order to acquire information automatically and forward it to cloud-based applications
- Calling up to three applications (Web pages, programs or databases) defined in the project, e.g. shift logs

For additional information, see:  
[www.siemens.com/simatic-pcs7/plant-asset-management](http://www.siemens.com/simatic-pcs7/plant-asset-management)

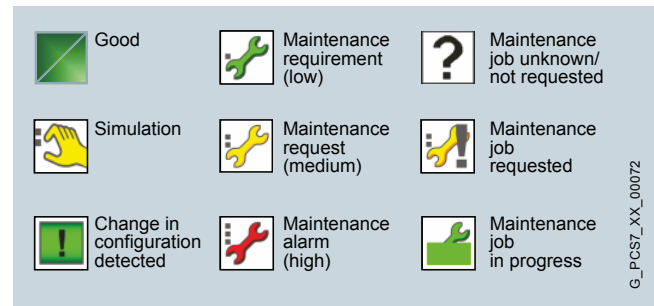

Extract from the PCS 7 asset management symbol set

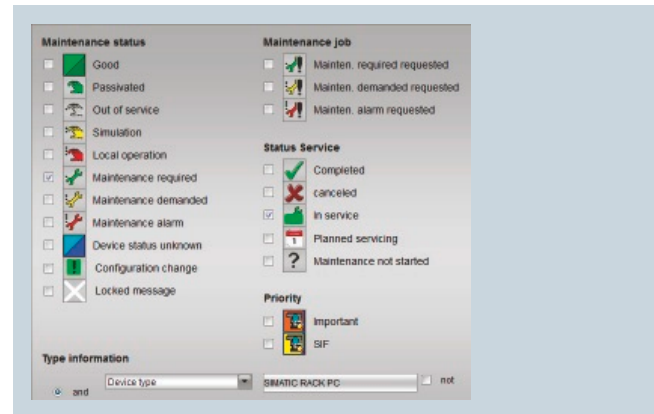

Filters for diagnostic states

### SIMATIC PCS 7 Maintenance Station at a glance

- System interface for the maintenance engineer
- Diagnostics and maintenance management for the components of the process control system and for mechanical assets such as pumps, motors or heat exchangers
- Uniform display of diagnostics and maintenance status throughout the plant
- Extended diagnostics information by integrating SIMATIC PDM
- Support for upgrade planning using identification data overview with version releases
- Function block for mechanical assets, individual diagnostics and condition monitoring functions
- Additive blocks for plant components (pumps, heat exchangers, control valves, etc.)
- Recording of changes in configurations and parameters of EDD-based devices in the change log
- Generation of overviews on diagnostics states
- Integration of internal and external applications for special diagnostics and additional information
- Consideration of international standards and directives

# Automation systems

Scalable performance for every requirement

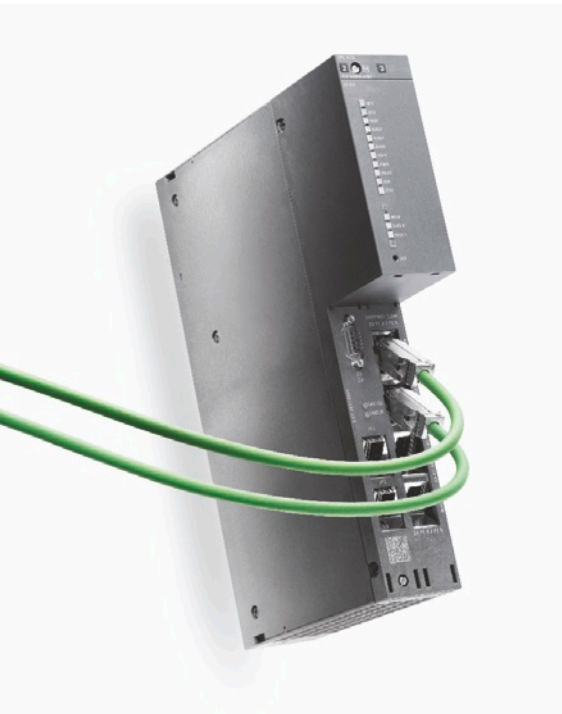

SIMATIC PCS 7 automation systems,  
AS 410 and Microbox (SIMATIC PCS 7 AS RTX)

Automation systems in the models shown above are available for the SIMATIC PCS 7 process control system. The automation performance can therefore be finely scaled within wide limits.

## SIMATIC S7-400 modular automation systems with hardware controller

The selected components of the SIMATIC S7-400 are combined in bundles based on the task with consideration of the price/performance ratio. These automation systems are extremely rugged and feature a high processing and communication performance. Other outstanding features include:

- Modular, fan-free design
- Extremely rugged and expandable
- Single and redundant versions
- Comprehensive communication facilities
- Integrated system functions
- Integratable safety functions (Safety Integrated)
- Simple linking of central or distributed I/O
- Redundant PROFINET IO support

They can be classified according to their functionality as:

- Standard automation systems
- Fault-tolerant automation systems
- Safety-related automation systems

Depending on the scale of performance and perspective orientation, they can be differentiated across classes as:

- **AS 410 automation systems**  
Scaling of universally applicable CPU type based on the number of process objects
- **Complementary SIMATIC S7-400 systems**  
Scaling of the hardware based on the performance levels of the CPU types

The rugged AS 410 is a modern, future-oriented, all-round system for the process industry. Due to its versatility, it can be used in every domain – as a standard AS 410S system, as a high-availability AS 410H or as safety-related AS 410F/FH. More and more innovative functions are being exclusively combined with this automation system, for example, redundant PROFINET configurations and configuration changes during operation for PROFINET in singular and redundant applications.

The CPU for all automation systems of the S7-400 series is already equipped as standard with the PROFIBUS DP fieldbus connection. Depending on the type of CPU, one or two additional PROFIBUS DP interfaces can be employed using additive IF 964-DP interface modules. If needed, up to 10 PROFIBUS communication modules can be additionally operated on a CPU. A PROFINET IO connection can be made via the CPU interface or a communication module, depending on the type.

### Standard automation systems

The modular standard automation systems of the S7-400 are available for universal use. These are always your first choice when fault tolerance or safety-related engineering functions are of secondary importance.

### Fault-tolerant automation systems

Fault-tolerant automation systems are used to reduce the risk of production failures. The higher investment costs are frequently negligible compared to the costs resulting from production failures. The higher the costs of a production failure, the more worthwhile it is to use a fault-tolerant system.

The two redundant and electrically isolated subsystems of the Redundancy Station can be mounted on one compact rack with divided backplane bus or on two separate racks. The design with two racks allows physical separation of the redundant subsystems over distances up to 10 km, e.g. separated by a fireproof partition. As a result of the electrical isolation, the system is insensitive to electromagnetic interferences.

Fault-tolerant SIMATIC PCS 7 automation systems can be used on their own or together with standard and safety-related automation systems.

### Safety-related automation systems

Safety-related automation systems are used for critical applications in which an incident can cause danger to personnel, plant damage or environmental pollution. These F/FH systems collaborate with safety-related F modules of the ET 200 distributed I/O systems or fail-safe transmitters connected directly via the fieldbus to detect not only faults in the process, but also their own, internal faults. They automatically bring the plant into a safe state in the event of a fault.

The safety-related automation systems are TÜV-certified and conform to the safety requirements up to SIL 3 in accordance with IEC 61508. They are based on the hardware of the high availability automation systems, which is expanded by safety functions with S7 F systems.

Analogous to the basic systems, they are available in two versions:

- Single stations with one CPU, safety-related
- Redundancy stations with two redundant CPUs, safety-related and fault-tolerant

The redundancy of the FH systems is only used to increase the availability. It is not relevant to processing of the safety functions or the associated fault detection.







Safety-related AS 410FH on PROFINET IO

In the multitasking systems, several programs can run simultaneously in one CPU, Basic Process Control System (BPCS) applications as well as safety-related applications. The programs are reaction-free, this means that faults in BPCS applications have no effect on safety-related applications and vice versa. Special tasks with very short response times can also be implemented.

With parallel processing of BPCS and safety functions in one CPU, mutual interference is prevented by ensuring the BPCS programs and the safety-related programs are kept strictly separate and the data exchange is by means of special conversion function blocks.

The safety functions are processed twice in different processor sections of the CPU by means of redundant, diverse instruction processing. Potential errors are detected by the system during the subsequent comparison of results.

Safety programs executed on different F/FH systems of a plant are also able to carry out safety-related communication with one another over the Industrial Ethernet plant bus.

#### Flexible and scalable availability

A particular characteristic of the modular S7-400 systems is the flexible and scalable availability of various modules. When planning a system, it is even possible with a Single Station to increase the availability at a specific point by means of redundant configuration of the power supply or for the Industrial Ethernet communication module and to combine these measures.

The Redundancy Station with its two redundant CPUs already offers a higher level of availability. It operates according to the 1oo2 principle, in which a switch is made from the active subsystem to the standby system in the event of a fault. Based on this, as with the Single Station the power supply or the Industrial Ethernet communication module can be doubled for each subsystem and these measures can be combined.

AS type	CPU	Interfaces			
		PN/IE (2 ports)	MDI/DP	DP	DP module as optional plug-in
<b>Standard systems</b>					
AS 410S	CPU 410-5H, CPU 410E and CPU 410SIS	2	–	1	–
AS 414-3	CPU 414-3	–	1	1	1
AS 414-3IE	CPU 414-3 PN/DP	1	1	–	1
AS 416-2	CPU 416-2	–	1	1	–
AS 416-3	CPU 416-3	–	1	1	1
AS 416-3IE	CPU 416-3 PN/DP	1	1	–	1
AS 417-4	CPU 417-4	–	1	1	2
<b>Fault-tolerant and safety-related systems</b>					
AS 410H/F/FH	CPU 410-5H, CPU 410E and CPU 410SIS (1 × or 2 ×)	2	–	1	–
AS 412H/F/FH	CPU 412-5H (1 × or 2 ×)	1	1	1	–
AS 414H/F/FH	CPU 414-5H (1 × or 2 ×)	1	1	1	–
AS 416H/F/FH	CPU 416-5H (1 × or 2 ×)	1	1	1	–
AS 417H/F/FH	CPU 417-5H (1 × or 2 ×)	1	1	1	–

Overview of the automation system types

## AS 410 automation systems

The AS 410 is an automation system of the SIMATIC S7-400 series that is envisaged for use in the SIMATIC PCS 7 process control system. With the innovative "CPU 410-5H Process Automation" and appropriately optimized firmware, the complete performance range of the complementary S7-400 automation systems can be covered (from AS 412H and AS 414-3 to AS 417H). The achieved reduction in the number of types not only simplifies the stocking of spare parts, but also provides advantages for the complete lifecycle of the process control system.

The performance levels are based on process objects (PO) of differently dimensioned system expansion cards. If its performance limit is reached during configuration, commissioning or operation, a subsequent increase in performance is possible with Expansion Packs. Hardware need not be exchanged in this case.

In addition to the CPU, the SIMATIC PCS 7 AS 410 bundles include an aluminum rack, communication modules and selected power supply modules with an additional enamel coating (conformal coating). The AS 410 XTR bundles created for higher temperatures up to 70 °C (Extended Temperature Range) extend the application range.

The CPU 410-5H Process Automation is equipped with one PROFIBUS DP and two PROFINET IO interfaces with a 2-port switch. Two integrated slots allow the synchronization of two redundant subsystems via sync modules and sync cables.

The CPU offers battery-free operation for easier handling and higher availability through retentive load memory. For program and data, 48 MB of retentive load memory and 32 MB work memory are integrated.

The AS 410 controller supports active security in the production area. It triggers security events at the controller level and contributes to timely detection of security incidents.

The SIMATIC CPU 410E offers an optimal automation solution for applications with a limit of up to 200 process objects. In combination with the CPU 410-5H, the CPU 410E can also be used as a distributed automation solution, e.g. for highly modular technological modules, that can be integrated in the overall plant via Plug-and-Produce.

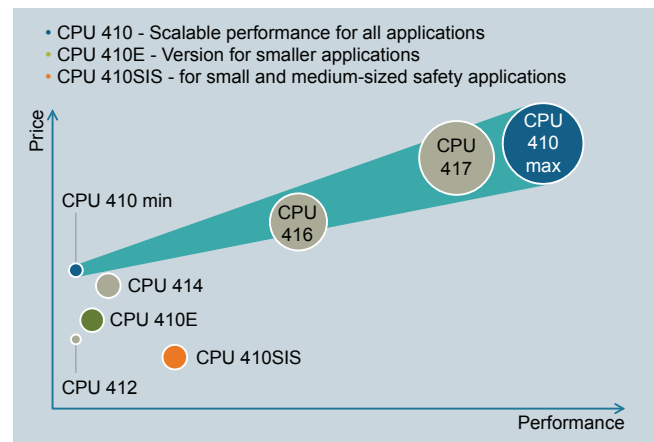

Positioning of the SIMATIC S7-400 product range

Automation system with APL	AS 412H	AS 414-3	AS 414-3IE	AS 414H	AS 416-2	AS 416-3	AS 416-3IE	AS 416H	AS 417-4	AS 417H	AS RTX
	← AS 410 with CPU 410-5H →										
	← AS 410E (up to 200 PO) →										
Analog value measurements	10	150	150	100	300	500	500	400	800	600	300
Digital value measurements	20	300	300	250	600	1 000	1 000	800	1 400	1 000	600
PID controls	5	50	50	50	100	200	200	150	250	200	200
Motors	7	75	75	75	150	250	250	200	450	400	150
Valves	7	75	75	75	150	250	250	200	450	400	250
SFC	0	15	15	15	60	100	100	100	200	200	100
Steps	0	150	150	150	700	1 000	1 000	1 000	2 000	2 000	800
Dosing	0	5	5	3	20	25	25	25	50	50	50
Digital inputs DI	30	450	450	300	900	1 500	1 500	1 200	2 200	1 800	1 200
Digital outputs DO	10	150	150	110	300	500	500	400	750	650	400
Analog inputs AI	15	225	225	150	450	750	750	600	1 100	900	600
Analog outputs AO	5	75	75	50	150	250	250	200	350	350	200
Process objects (PO)	30	450	450	350	900	1 500	1 500	1 200	2 200	2 000	1 200

Typical mixed configuration limits for SIMATIC PCS 7 automation systems, based on the SIMATIC PCS 7 Advanced Process Library (APL)

### SIMATIC PCS 7 AS RTX embedded automation system with software controller

The SIMATIC PCS 7 AS RTX based on the SIMATIC IPC 427D (Microbox) is a compact and rugged automation system designed for the low and medium performance range. It is designed for maintenance-free 24-hour continuous operation at ambient temperatures between 0 and 50 °C. Since it works without fans or rotating storage media, it is also relatively insensitive to vibration and shock.

Due to its excellent physical properties, its small dimensions and the flexible mounting options (DIN rail, wall or portrait mounting in horizontal or vertical orientation), it is especially ideal for use at the plant level, for example in package units or in laboratory automation.

Depending on the preferred field communication, the customer can select between the SIMATIC PCS 7 AS RTX PROFIBUS or SIMATIC PCS 7 AS RTX PROFINET product versions.

ET 200M, ET 200iSP and ET 200pro remote I/O stations can be linked to a comprehensive range of low-cost signal/function modules as well as intelligent field/process devices on the PROFIBUS PA via the PROFIBUS DP interface integrated in SIMATIC PCS 7 AS RTX PROFIBUS.

Sensors/actuators at remote ET 200SP or ET 200M I/O stations can be connected to the SIMATIC PCS 7 AS RTX PROFINET via PROFINET IO. This features a PROFINET interface with 3 ports.

For connection to the SIMATIC PCS 7 plant bus, the SIMATIC PCS 7 AS RTX PROFINET provides one, and the SIMATIC PCS 7 AS RTX PROFIBUS provides two Ethernet ports with 10/100/1000 Mbps (RJ45).

### Automatic systems at a glance

#### Modular systems of the SIMATIC S7-400 series

- Individually configurable AS bundles, available as:
  - Individual components, bundled in stations
  - Pre-assembled and tested stations
- Flexible and scalable availability:
  - Standard systems as single station, optionally with redundant power supply
  - Fault-tolerant and safety-related systems as single/redundancy station; redundant power supply and/or Industrial Ethernet interface as options
- Redundancy Station with two electrically isolated subsystems
  - One or two racks (distances up to 10 km)
  - Synchronous processing of identical user programs
  - Bumpless switchover
- Changes to the configuration during operation

#### SIMATIC PCS 7 AS RTX embedded system

- Compact and rugged Microbox system for use at the plant level, ideal for package units
- Resistant to vibration and shock, no fans or rotating storage media
- Maintenance-free 24/7 operation at ambient temperatures up to 50 °C
- Product versions for connecting process I/O via PROFIBUS DP/PA or PROFINET IO

The Windows operating system, the WinAC RTX controller software and the SIMATIC IPC DiagMonitor diagnostic software are pre-installed on the integrated solid state disk. Configuration is performed with the SIMATIC PCS 7 engineering system. The supplied AS Runtime license can be expanded to up to 2 000 POs.

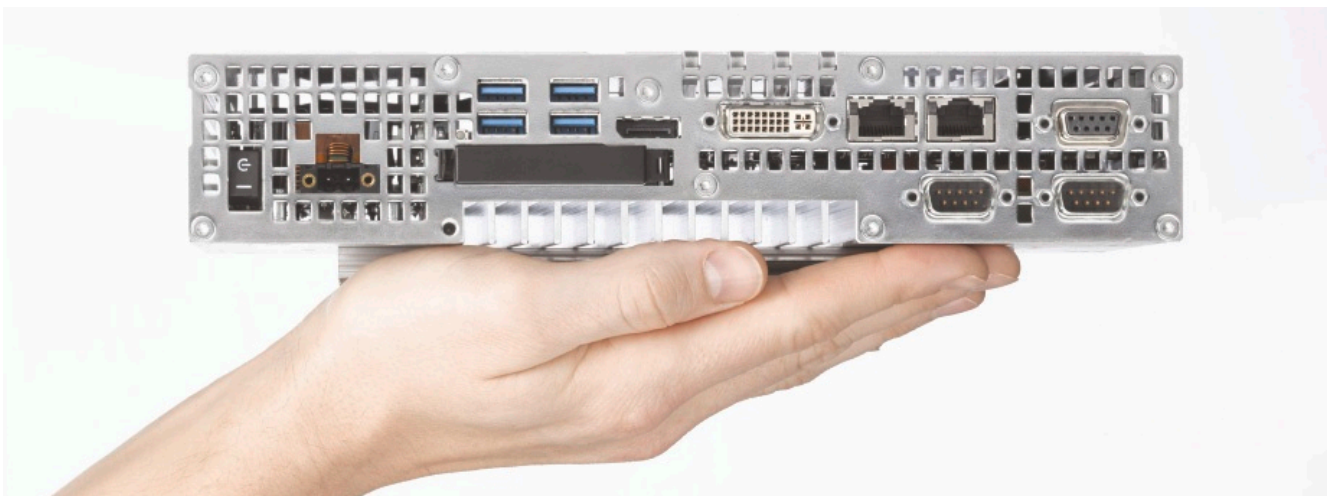

# Compact systems

## SIMATIC PCS 7 BOX – complete control system in compact design



SIMATIC PCS 7 BOX RTX compact system

SIMATIC PCS 7 BOX enhances the SIMATIC PCS 7 range with low-price, rugged and space-saving industrial PC systems with versatile application options, e.g. as:

- Client in an operator system or in SIMATIC BATCH
- Compact process control system with system functionality for engineering (ES), automation (AS), HMI (OS)
- Runtime system with system functionality as above, but without engineering

The SIMATIC PCS 7 BOX compact systems are ideally suited for plant-level automation.

- Small applications/units in production processes
- Package units (enclosed subprocesses)
- Laboratories or institutes

They are also highly suitable as training systems for operators and service engineers.

The application of standard SIMATIC PCS 7 components ensures scalability and unlimited expansion without a change in compatibility. With increasing requirements, e.g. if a test system is subsequently to be operated as a productive system of larger scale, expansion with SIMATIC PCS 7 system components is possible without problem, as is integration into the production plant.

The product range is primarily differentiated by the automation functionality, that is, by the controller type and the type of communication in the field area:

- **SIMATIC PCS 7 BOX RTX** with integrated WinAC RTX software controller, optionally with PROFIBUS or PROFINET interface
- **SIMATIC PCS 7 BOX** in combination with a separate external controller:
  - Microbox automation system as SIMATIC PCS 7 AS RTX PROFIBUS/PROFINET
  - Modular automation system of the S7-400 series with PROFIBUS and PROFINET interface as single or redundancy station

The selection depends on the price/performance ratio and on the supported hardware and software functionalities.

The two basic types can be differentiated further depending on whether the engineering is concentrated in a central engineering system or integrated in the compact system:



- SIMATIC PCS 7 BOX RTX
  - ES/OS system with ES + OS + AS functionality
  - OS Runtime system with OS + AS functionality
- SIMATIC PCS 7 BOX
  - ES/OS system with ES + OS functionality
  - OS Runtime system with OS functionality

A complete process control system for small applications can be implemented by expanding with distributed process I/Os. Depending on the type of field communication, the ET 200M, ET 200SP, ET 200iSP or ET 200pro remote I/O stations are supported by a comprehensive range of low-cost signal/function modules, but also by field devices connected directly over the fieldbus.

The compact systems can be incorporated into the PCS 7 asset management using the integrated SIMATIC IPC DiagMonitor diagnostic software. Equipped as an ES/OS system with additional software licenses for SIMATIC PDM and SIMATIC PCS 7 Maintenance Station, a compact system can also be operated as a maintenance station.

SIMATIC PCS 7 BOX systems with an external controller are also suitable for SIMATIC BATCH (up to 10 units) or as a Web server for up to two Web clients.

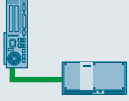

System configuration		PCS 7 BOX RTX	SIMATIC PCS 7 BOX		
		 WinAC RTX Controller Integrated	 PCS 7 AS RTX (Microbox) as separate controller	 Modular AS 41x (AS Single Station) as separate controller	 Modular AS 41xH/F (single/redundant) as separate controller
Supported functions and limits	<b>Software</b>				
	AS/OS Engineering	●	●	●	●
	OS Runtime Single Station up to 2 000 OS runtime PO	●	●	●	●
	PCS 7 APL	●	●	●	●
	SIMATIC PDM PCS 7	●	●	●	●
	SIMATIC PCS 7 Maintenance Station	●	●	●	●
	SIMATIC BATCH up to 10 units		●	●	●
	Web server for up to 2 Web clients		●	●	●
	OS Single Station Redundancy		●	●	●
	S7 F Systems				●
	SIMATIC Safety Matrix				●
	<b>Hardware</b>				
	Controller (AS) independent of the BOX PC system		●	●	●
	AS-to-AS communication	●	●	●	●
	Routing	● <sup>1)</sup>	● <sup>1)2)</sup>	●	●
	PROFIBUS DP/PA	●	●	●	●
	FOUNDATION Fieldbus (FF)			●	●
PROFINET IO	●	●	●	●	
Configuration in RUN (CiR)			●	●	
High-precision time stamps			●	●	
S7 Block Privacy			●	●	
Block type change in Run (TCiR)			● (AS 410)	● (AS 410)	
Retentive AS data	● (Only with UPS)	● (Only with UPS)	●	●	
Max. AS Runtime PO <sup>3)</sup>	1 200	1 200	2 000	2 000	

Supported hardware and software functionality depending on the system configuration

<sup>1)</sup> The PROFIBUS routing functionality of the WinAC RTX 2010 can only be used with the onboard CP of the SIMATIC PCS 7 BOX RTX and the PCS 7 AS RTX.

<sup>2)</sup> The PROFINET routing functionality of the WinAC RTX 2010 can only be used with the onboard CP of the PCS 7 AS RTX.

<sup>3)</sup> Typical mixed quantity structures based on the SIMATIC PCS 7 Advanced Process Library (APL)

## Design versions

The compact systems are operated and monitored as standard using separate control units (mouse, keyboard, process monitor).

An alternative design version with front panel (photo on right) also permits operation and monitoring using a 22" TFT panel with touch screen, resolution of 1920 × 1080 pixels.

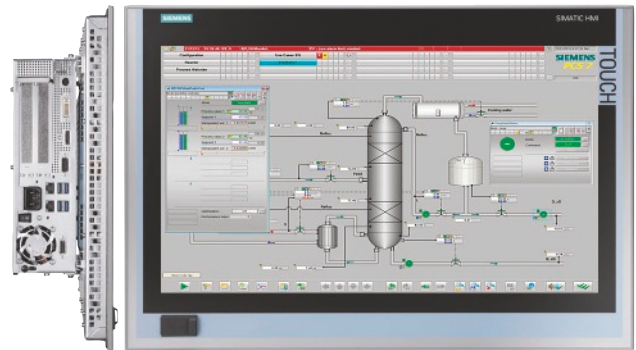

SIMATIC PCS 7 BOX with panel front, side and front views

# Industrial Communication

Fast and reliable communication for plant bus and terminal bus

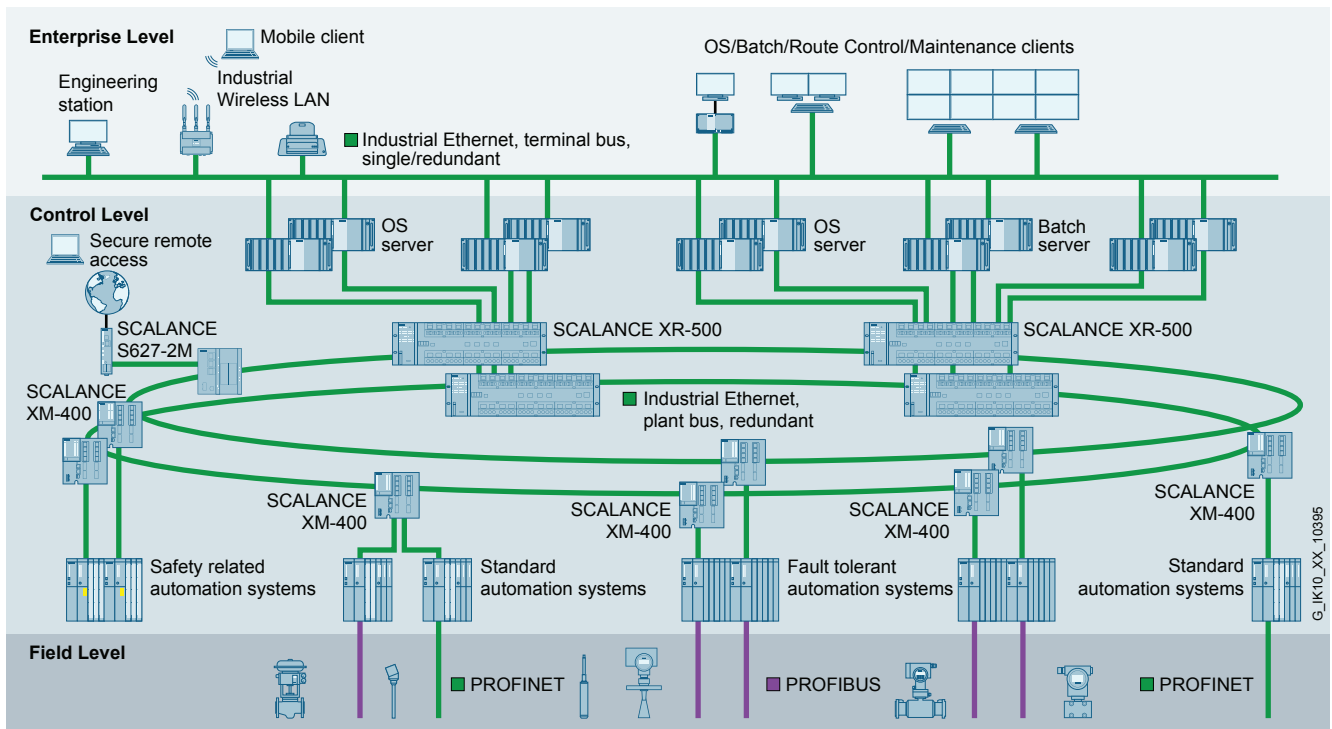

Configuration example for plant and terminal bus

## Industrial Communication with SIMATIC NET

Through application of SIMATIC NET network components based on globally established standards, SIMATIC PCS 7 is provided with a powerful and rugged range of products for implementing integrated communications networks for reliable data exchange between the system components in different levels of a plant.

The SIMATIC NET products specially developed for industrial applications provide optimum suitability for plants in all sectors. They are matched to one another and meet the highest standards, especially in areas where they are subject to extreme influences:

- Electromagnetic interference fields
- Corrosive liquids and atmospheres
- Explosion hazards
- High mechanical loads

The SIMATIC NET products ensure expandability and the protection of investments due to compatible further developments, as well as integration from inbound logistics to outbound logistics and from field devices up to the management information system.

## Industrial Ethernet

The plant bus and the terminal bus for multiple station systems with client/server architecture are implemented with Industrial Ethernet, a powerful area and cell network for industrial applications in line with the international IEEE 802.3 standard (Ethernet).

In the various SIMATIC PCS 7 subsystems (ES, OS, AS, etc.), onboard interface modules, simple network adapters or special communications processors are used as communication interfaces. For small systems, single stations and servers can be economically operated on the plant bus with simple network adapters using the "Basic Communication Ethernet" integrated in the PCS 7 Industrial Workstations.

In medium-sized and large plants SIMATIC PCS 7 relies on high-performance communication modules and modern Gigabit and FastEthernet technology. This combines the high reliability of optical rings with the scalable performance provided by switching technology and transmission rates of up to 10 Gbps.

# Industrial Ethernet Switches / Industrial Wireless LAN

## Industrial Ethernet switches

Industrial Ethernet switches are used for integration of communication participants in the plant bus. The switches from the SCALANCE X product series are particularly suitable for this and offer scalable performance at an attractive price while supporting versatile configuration possibilities.

The products from the SCALANCE X product series authorized for SIMATIC PCS 7 are multi-faceted, and the types are differentiated by port count, modularity, flexibility and functionality. You can choose between switches with FastEthernet ports for data rates to 100 Mbps or with Gigabit Ethernet ports. SCALANCE X-500 also features optical 10 Gigabit Ethernet ports.

Ring topologies are predestined for the plant bus and terminal bus due to their high availability. An additional advantage of optical rings is their EMC immunity.

## Redundant ring topology

If availability requirements are particularly high, it is possible to distribute the communication on two physically separated redundant rings. One switch in each case takes over the function of the redundancy manager for each ring.

### ■ Terminal bus

The PCS 7 stations are connected to each of the two rings via an Industrial Ethernet interface. On the PCS 7 stations, the SIMATIC NET SOFTNET IE RNA communication software organizes the communication processes by means of the Parallel Redundancy Protocol (PRP) in accordance with IEC 62439-3. Terminal equipment with only one Industrial Ethernet connection, e.g. the SICLOCK TC 400 central plant clock, can be integrated via SCALANCE X204RNA.

### ■ Plant bus

The coupling partners connected to the two rings by means of two Industrial Ethernet interfaces per AS CPU and OS server are linked together logically when configuring with NetPro by using a fault-tolerant S7 connection (4-way redundancy).

## Industrial Communication for the process industry

With the SCALANCE XF204-2BA DNA<sup>1)</sup>, Siemens offers a new compact switch specially designed for use with redundant SIMATIC S7-400H systems or the SIMATIC ET 200SP HA distributed I/O. It follows the recommendations of NAMUR NE 21 and is therefore suitable for use in process automation.

<sup>1)</sup> Please note that when SCALANCE XF-200BA is used, at present the diagnostics can only be carried out by one CPU in the H-system and configuration changes during operation (CiR function) are not supported (Firmware update under development).

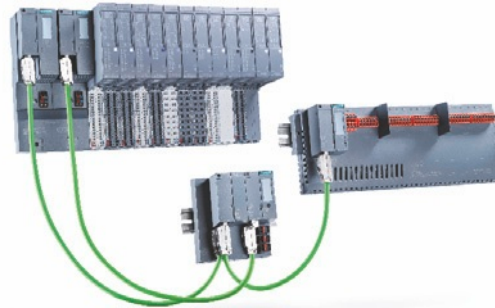

The switch with dual network access functionality (DNA or Y-switch functionality) connects a redundant PROFINET ring consisting of S2 devices (field area) to a high-availability PROFINET system (R1 system). Besides the two "Y-switch" ports, two other switch ports are also available at the device end. These can for example be used to operate an MRP ring.

## Industrial Wireless LAN (IWLAN)

SIMATIC PCS 7 provides the option for integrating mobile or stationary remote clients via an IWLAN access point of the SCALANCE W760, W770 or W780 product series on the terminal bus.

Mobile remote clients (e.g. notebooks) can communicate with the IWLAN access point using a WLAN interface module and stationary remote clients in a desktop/tower housing (PCS 7 Industrial Workstations) can communicate using an IWLAN client module of the SCALANCE W720, W730 or W740 product series.

The following applications can then be implemented:

- Use of additional remote OS clients (up to 2 clients on IWLAN)
- Linking of Web clients to a SIMATIC PCS 7 Web server (up to 2 Web clients on IWLAN)
- Remote access to an engineering station, for example for commissioning.

All components used are very rugged, apply state-of-the-art authentication and encryption procedures and guarantee high reliability of the radio channel. You can achieve gross data transfer rates of up to 450 Mbps by means of link aggregation and parallel use of several antennas (MIMO technology) in accordance with the international standard IEEE 802.11n.

# PROFINET in the process industry

PROFINET combines the advantages of PROFIBUS, the most popular fieldbus system worldwide, with modern Ethernet technology. PROFINET allows easy setup of flexible communication networks and ensures integrated, reliable and secure communication throughout the plant – in real time!

Greater flexibility, efficiency and performance in industrial communication – PROFINET has already proven successful for many years in the manufacturing and machine environment and is the preeminent global standard in automation.

PROFINET more than meets the special requirements of the process industry regarding availability, flexibility, real-time capability and ruggedness. At the same time, the Ethernet-based technology convinces with its easy handling.

The process industry is also benefiting from the modern communication technology, and the foundation has now been laid for the SIMATIC PCS 7 process control system:

- Scalable system redundancy
- Changes possible during operation ("Configuration in Run")
- High-precision time-of-day synchronization for sequence of events ("SoE")

PROFINET fully complies with the Ethernet standard in IEEE 802.3 and is thus the reliable future-proof standard that paves the way for digitalization in the process environment.

Combine investment protection with security for the future: On the one hand, the open Industrial Ethernet standard supports the integration of existing plant units and technologies. Appropriate solutions and products, such as the IE/PB LINK for integration of PROFIBUS DP and the SIMATIC CFU PA for integration of PROFIBUS PA, are available for this. On the other hand, worldwide standardization in accordance with IEC 61158/61784 and consistent ongoing development ensure the use of PROFINET over the entire life cycle of the plant and beyond. Even wireless communication technologies such as WLAN in accordance with IEEE 802.11 and mobile communications can be reliably integrated.

Intelligent field devices autonomously supply status information regarding diagnostics and maintenance. This information is rounded out by the PROFINET diagnostics. Network problems and device conflicts are reliably detected and can be quickly remedied. Digitalization and the accompanying Big Data call for integrated communication down to the field level and require flexible as well as reliable communication networks.

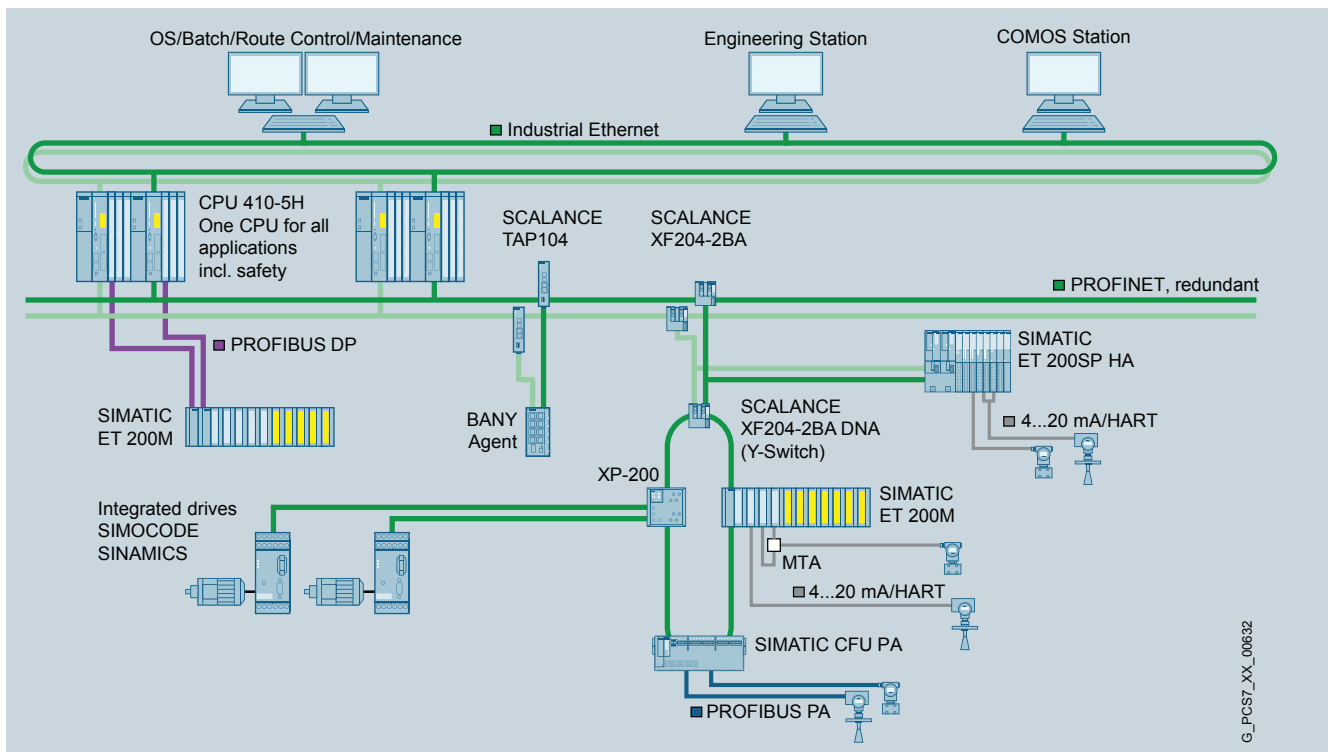

G\_PCS7\_XX\_00632



### Step-by-step into the future

Existing fieldbuses in the "installed base" can integrate PROFIBUS to PROFINET in steps because the systems are compatible.

PROFINET allows you to freely scale the availability of your plant based on your requirements. In addition to media redundancy in the ring (MRP), two forms of system redundancy are also available:

#### Simple system redundancy (S2)

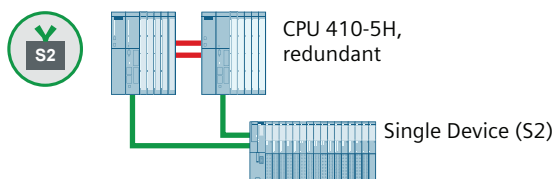

#### Modular system redundancy (R1)

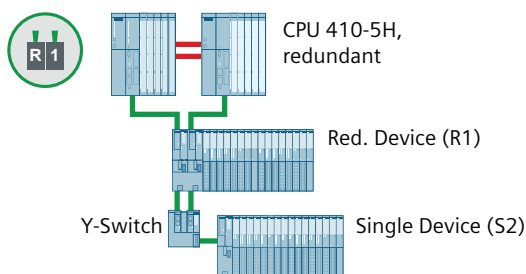

The hardware portfolio has undergone fundamental further development in order to make full use of the new PROFINET options:

- CPU 410-5H V8.2
- SIMATIC ET 200SP HA
- SIMATIC CFU PA
- SCALANCE XF204-2BA DNA ("Y-switch")

The SIMATIC PCS 7 CPU 410-5H with firmware version V8.2 enables setup of redundant automation systems and redundant devices (R1) for a high-availability H-system through redundant PROFINET IO configuration.

Through the "Y-switch" SCALANCE XF204-2BA DNA, a network configuration with system redundancy (S2) to the field level can be connected to an H-system (R1). MRP networks are also supported by the switch.

The redundant communication of devices in the ring is established through the Media Redundancy Protocol (MRP).

### Redundant network configuration R1, S2 and MRP

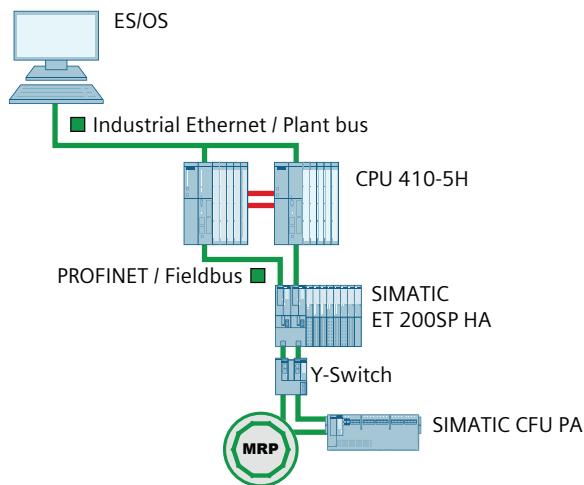

The SIMATIC ET 200SP HA distributed I/O and the "Compact Field Unit" field distributor (SIMATIC CFU PA) have a PROFINET interface for S2 redundancy. This produces flat and flexible architectures that support easier plant expansions without having to maintain reserves and offer potential for significant savings in cabling. The motto "One cable for all purposes" supports parallel operation of profiles such as PROFIsafe, PROFIdrive and other TCP/IP protocols without impacting basic plant communication. These hardware components use the BusAdapter technology, which supports simple and flexible connection to the PROFINET network either with copper cables (RJ45 or FastConnect) or fiber-optic cables.

PROFINET in combination with appropriate hardware components supports you during planning, operation and commissioning: Easy device replacement without additional tools through automatic neighborhood detection as well as clear and simple installation guidelines including automatic addressing and name assignment.

#### Configuration in Run (CiR)

To maintain plant availability during this work, the components allow changes to be made in the plant during operation ("Configuration in Run", CiR) without affecting the production process. This is available for an H-system (H-CiR) and for a single station (CiR).

#### Advantages of PROFINET at a glance

- Ethernet at the field level
- Maximum availability if required
- More flexibility
- Easy handling
- Investment protection

# Fast and rugged fieldbus communication

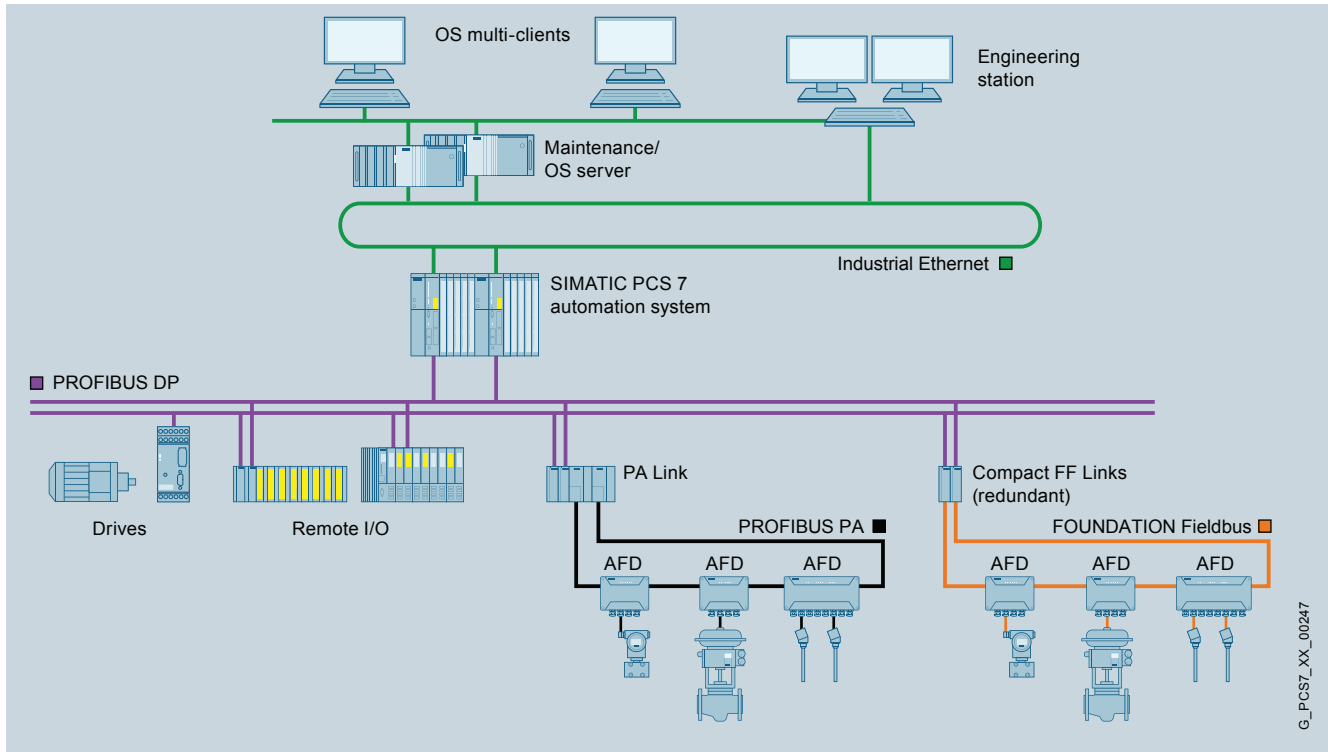

System integration of PROFIBUS PA and FOUNDATION Fieldbus H1 via PROFIBUS DP

Distributed peripherals such as remote I/O stations with their I/O modules, transmitters, drives, valves or operator terminals communicate with the automation systems at field level through a powerful real-time bus system. This field communication is characterized by:

- Cyclic transmission of process data
- Acyclic transfer of alarms, parameters and diagnostics data

The universal PROFIBUS has already proven itself in numerous projects as a rugged and reliable communication medium at the field level. Based on the IEC 61158 and IEC 61784 standards, it can cover all requirements of the production and process industries, with:

- Complementary transmission technologies
- Uniform communication profile
- Additive application profiles for typical device functions, e.g. PA Devices, PROFIdrive, PROFIsafe or PROFlenergy.

## PROFIBUS DP

PROFIBUS DP is designed to provide high data transmission rates and short response times (up to 1 ms) and is at the same time:

- Communication medium for data transmission between automation systems and distributed I/O devices of the ET 200 series, as well as field devices, drives, analyzers, CPUs/CPs, operator panels etc. that have a PROFIBUS DP interface
- Integrator for the PROFIBUS PA fieldbus and FOUNDATION Fieldbus H1 which are typical in the process industry

Due to the support of the HART protocol, HART field devices can also be connected via the PROFIBUS DP.

The PROFIBUS DP is available for electrical or optical transmission:

- RS 485: Simple and low-cost electrical transmission system with a shielded two-wire cable.
- Fiber-optic: optical transmission system with glass or plastic fiber-optic cables, for fast transmission of large quantities of data in environments with high interferences or for covering long distances.

With the fieldbus isolating transformer and RS 485-iS electrical transmission technology, PROFIBUS DP can also be run as an intrinsically-safe fieldbus in all environments up to hazardous zone 1 or 21.

### PROFIBUS PA and FOUNDATION Fieldbus H1

The direct connection of transmitters and actuators including power supply via the communication medium, as well as detailed diagnostics, are particularly relevant to the automation of industrial processes that frequently take place in corrosive, harmful and hazardous environments.

This requirement profile is met by PROFIBUS PA and FOUNDATION Fieldbus H1 (FF H1). Both fieldbuses are optimally suitable for direct integration of field devices in operating environments up to Ex zone 1/21 or 0/20 into the process control system. The intrinsically-safe transmission technology MBP (Manchester Coded; Bus Powered)

provides the power supply to the field devices as well as digital data transmission with a constant transfer rate of 31.25 Kbps over a two-wire cable.

The physical bus systems of PROFIBUS PA and FF H1 are largely identical in accordance with IEC 61158. Both can be integrated seamlessly in the SIMATIC PCS 7 process control system using PROFIBUS DP as link. PROFIBUS PA and FOUNDATION Fieldbus H1 thus profit equally from the higher-level PROFIBUS DP architecture. SIMATIC PCS 7 customers are therefore not restricted to a specific fieldbus but can freely select one to obtain the optimum field instrumentation.

Technical specifications	PROFIBUS PA	FOUNDATION Fieldbus H1
Data transmission	MBP	MBP
Transfer rate	31.25 Kbps	31.25 Kbps
Cable	Two-wire shielded	Two-wire shielded
Type of protection	Ex ia/ib/ic	Ex ia/ib/ic
Topology	Linear, tree, ring	Linear, tree, ring
Safety Integrated	●	–
Control in the field	–	●
Interoperability	●	●
Field devices per segment/coupler	31 (typical 16 to 20)	31 (typical 8 to 10)
Field devices per link	64	31
Active field distributors per segment/coupler		
– AFD	8	8
– AFDiSD or combinations of AFDiSD and AFD	5	5
Max. total current consumption of all field devices	1 A	0.5 A
Cable length per segment	1 900 m	1 900 m



Active field distributors AFD and AFDiSD

## Fieldbus architectures

PROFIBUS PA and FOUNDATION Fieldbus H1 (FF H1) are integrated in SIMATIC PCS 7 via PROFIBUS DP. The possible fieldbus architectures depend on whether PROFIBUS DP master and fieldbus PROFIBUS DP are configured as single or redundant.

### Line architecture with single coupler

If the gateway is an independent DP/PA coupler or Compact FF Link, a single line segment can be connected to it. A maximum of 5 line segments can be operated via single couplers (max. 3 for mixed configurations with ring or coupler redundancy) on a PA Link gateway.

When the FDC 157-0 coupler or the Compact FF Link are used, field devices can be integrated into the line segment via AFD and AFDiSD active field distributors (see bottom right). Alternatively, it is possible to operate up to 8 AFD active field distributors, up to 5 AFDiSD field distributors or any combination of up to 5 AFDiSD and AFD field distributors in a line segment. The field devices are connected to these field distributors over short-circuit-proof spur lines.

For PA devices in Ex zone 1/21, connection via a line segment on the DP/PA coupler Ex [i] (in the PA Link or independently) is a possible alternative.

### Line architecture with coupler redundancy

Either a line architecture with Active Field Splitter (AFS) or a ring architecture can be implemented with a gateway consisting of a PA Link with a redundant DP/PA coupler pair or a redundant Compact FF Link pair.

With the linear architecture, the AFS linked to the two coupling partners of the gateway interconnects the line segment to which it is attached with the respective active coupler partner. A coupler partner can be replaced without interrupting ongoing operation.

### Ring architecture

Maximum availability is achieved with a ring segment. Active field distributors integrate the field devices into this ring segment via short-circuit proof spur lines. An extension on the fieldbus or replacement of a coupler during operation is possible. The ring architecture provides the following benefits:

- Maximum availability avoids unplanned plant downtimes
- Simple and safe installation
- Automatic termination
- Automatic, bumpless isolation of faulty subsegments
- Topology can be repaired or expanded during ongoing operation

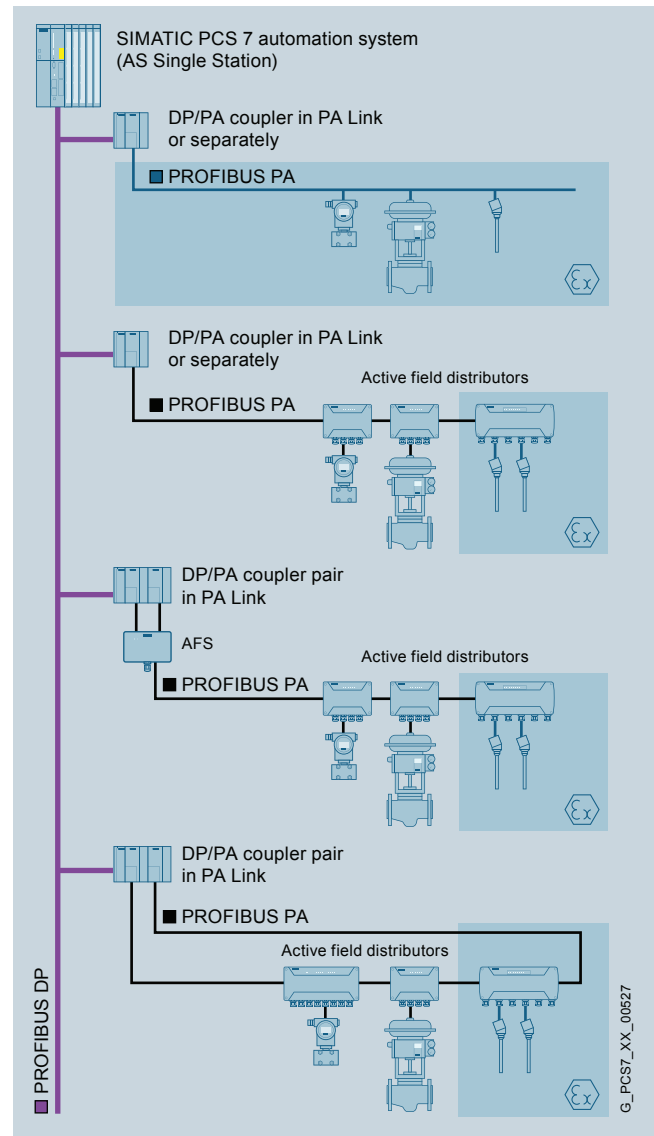

Example for fieldbus architectures, here with PROFIBUS PA

## Enhanced fieldbus diagnostics for PROFIBUS PA with AFDiSD

AFDiSD diagnostics are limited to short-circuits, loss of redundancy, detection of chatter, and failure of field devices. This functionality can be extended for PROFIBUS PA with a commissioning wizard, continuous operational monitoring and support for troubleshooting. This enables comprehensive diagnostics of the entire PROFIBUS PA segment. Errors in the configuration or defects can thus be quickly identified and remedied.

Extended PROFIBUS PA diagnostics enables identification, detection and monitoring of:

- Topology (DP/PA coupler, AFDiSD)
- Voltage and currents on the main and spur lines
- Signal and noise levels
- Capacitive unbalance to shield of main line



# Process I/O

## The right solution for any requirement

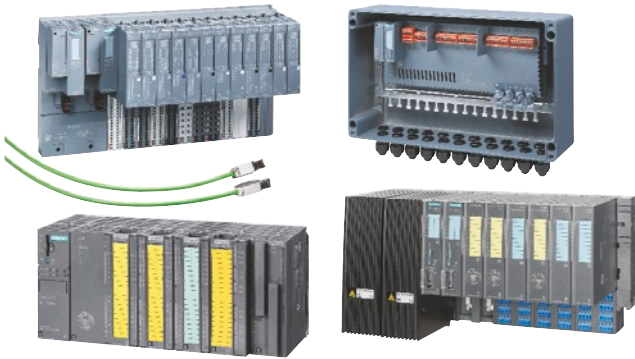

SIMATIC ET 200 remote I/O stations for SIMATIC PCS 7 (main lines SIMATIC ET 200SP HA, SIMATIC CFU PA, SIMATIC ET 200M and SIMATIC ET 200iSP)

SIMATIC PCS 7 offers a variety of options for detecting and outputting process signals via sensors and actuators as well as for connecting process I/O to the automation systems:

- Signal and function modules in remote I/O stations on the fieldbus
  - PROFIBUS DP (ET 200M, ET 200iSP, ET 200pro)
  - PROFINET IO (ET 200SP HA, SIMATIC CFU, ET 200M, ET 200SP)
- Analog and digital I/O modules of the SIMATIC S7-400 operated centrally in the automation system

In practice, field automation is characterized by distributed process I/O, which, depending on the type, also supports redundant configurations or operation in hazardous gas/dust atmospheres:

- SIMATIC ET 200 remote I/Os in conjunction with classic field/process devices and HART field devices
- Intelligent field/process devices for direct fieldbus connection

In addition to the wide technical bandwidth, the following properties characterize the distributed process I/O:

- Modularity and consistency
- Flexible adaptability to the plant structure
- Minimum cabling and engineering requirements
- Low commissioning, service and life cycle costs

S7-400 signal modules that can be operated centrally in the automation system are an alternative to distributed I/O for small applications or plants with limited distributed expansion.

### Standard process I/Os for SIMATIC PCS 7

The following distributed standard process I/Os can be used for field automation with SIMATIC PCS 7:

- Via PROFINET:
  - Compact Field Unit SIMATIC CFU
  - SIMATIC ET 200SP HA
  - SIMATIC ET 200M and ET 200SP
- Via PROFIBUS:
  - SIMATIC ET 200M, ET 200iSP and ET 200pro
  - PROFIBUS PA devices with PA profile 3.0 or later
  - Drives based on standard message frame types 1/20 of the PI specification "Profile Drive Technology PROFdrive"
  - Switchgear according to profile type 1 specification "Profiles for Low Voltages Switchgear Devices"

This process I/O can be integrated with standard function blocks from the Advanced Process Library in SIMATIC PCS 7.







More features specifically tailored to the process I/Os are offered as add-on products for SIMATIC PCS 7, for example:

- SIMOCODE pro motor management system
- SINAMICS drive systems
- SIWAREX U/FTA/FTC weighing systems
- Circuit breakers 3WL/3VA/3VL
- Measuring devices 7KM PAC3200/4200

Remote I/O		Possibilities for online changes
PROFINET	ET 200SP HA	<ul style="list-style-type: none"> <li>■ Adding ET 200SP HA stations</li> <li>■ Adding of I/O modules to the station</li> <li>■ Changing the parameter settings of I/O modules</li> <li>■ Parameterization of connected HART field devices with SIMATIC PDM</li> </ul>
	CFU	<ul style="list-style-type: none"> <li>■ Adding of CFU</li> <li>■ Adding of field devices to CFU</li> <li>■ Changing the parameter settings of the CFU and connected PA field devices over SIMATIC PDM</li> </ul>
PROFIBUS	ET 200M	<ul style="list-style-type: none"> <li>■ Adding of ET 200M stations</li> <li>■ Adding of I/O modules to the station</li> <li>■ Changing the parameter settings of I/O modules</li> <li>■ Parameterization of connected HART field devices with SIMATIC PDM</li> </ul>
	ET 200iSP	<ul style="list-style-type: none"> <li>■ Adding of ET 200iSP stations</li> <li>■ Adding of modules to the station</li> <li>■ Changing the parameter settings of modules</li> <li>■ Parameterization of connected HART field devices with SIMATIC PDM</li> </ul>
	ET 200pro	<ul style="list-style-type: none"> <li>■ Adding of ET 200pro stations</li> </ul>
	PROFIBUS DP, PROFIBUS PA, FOUNDATION Fieldbus H1	<ul style="list-style-type: none"> <li>■ Adding of PROFIBUS DP stations</li> <li>■ Adding of PA links and PA field devices</li> <li>■ Parameter assignment of PA or FF field devices with SIMATIC PDM</li> </ul>

# Distributed I/O devices

## Recommended devices for field automation

I/O system	SIMATIC CFU	ET 200SP HA	ET 200iSP	ET 200M	ET 200SP	ET 200pro
						
<b>Design</b>						
Degree of protection	IP20	IP20	IP30	IP20	IP20	IP65/IP66/IP67
Model	Compact	Modular	Modular	Modular	Discretely scalable	Modular
Mounting	Mounting rail	Mounting rail	Mounting rail	Mounting rail	Standard sectional rail	Mounting rail
Connection system for sensors/actuators	Multi-conductor connection Screw-type system	Multi-conductor connection Push-in-terminals	Multi-conductor connection Spring-loaded/ screw-type system	Single-conductor connection Spring-loaded/ screw-type system, FastConnect, TopConnect	Single/multi-conductor connection Push-in-terminals	M8, M12, M23
<b>Special applications</b>						
Safety	–	–	●	●	–	●
For use in hazard. areas	Zones 2, 22	Zone 2	Zones 1, 21	Zone 2	Zone 2	–
Increased availability	Redundant	Switched, redundant	Switched, redundant	Switched, redundant	–	–
Temperature range	-40 ... +70 °C (horizontal)	-40 ... +70 °C (horizontal)	-20 ... +70 °C	0 ... +60 °C	0 ... +60 °C (horizontal)	-25 ... +55 °C
Vibration resistance (continuous)	1 g	1 g	1 g	1 g	up to 5 g	5 g (module-dependent)
<b>Communication</b>						
PROFIBUS (Cu/FO)	– / –	– / –	● / – (1.5 Mbps)	● / – (12 Mbps)	– / –	● / ● (12 Mbit/s)
PROFINET (Cu/FO)	● / ●	● / ●	– / –	● / –	● / ●	– / –
<b>System functions</b>						
Permanent wiring	●	●	●	● (insertion and removal)	●	–
Hot swapping	–	●	●	● (with active backplane bus)	●	●
Expansion/configuration during ongoing operation	● / ●	● / ●	● / ●	● / ●	– / –	– / –
Diagnostics (module-dependent)	Channel-discrete	Channel-discrete	Channel-discrete	Channel-discrete	Channel-discrete	Channel-discrete
<b>Functions</b>						
Digital channels	●	●	●	●	●	●
Analog channels	●	●	●	●	●	●
incl. HART	PROFIBUS PA	●	●	●	●	–
Motor starter	–	Under developm.	–	–	–	–
Pneumatic interface	–	Under developm.	●	–	–	–
Technological functions	Under developm.	Under developm.	Counting, frequency measuring	Counting/measuring, controlling, weighing	–	–

The **SIMATIC ET 200iSP** is available as a turn-key solution in an IP65 stainless steel enclosure for Ex zone 1/21. The available type test certificate for certain built-on/built-in parts eliminates the need for additional individual acceptance. Feel free to contact us: [cabinets.industry@siemens.com](mailto:cabinets.industry@siemens.com)



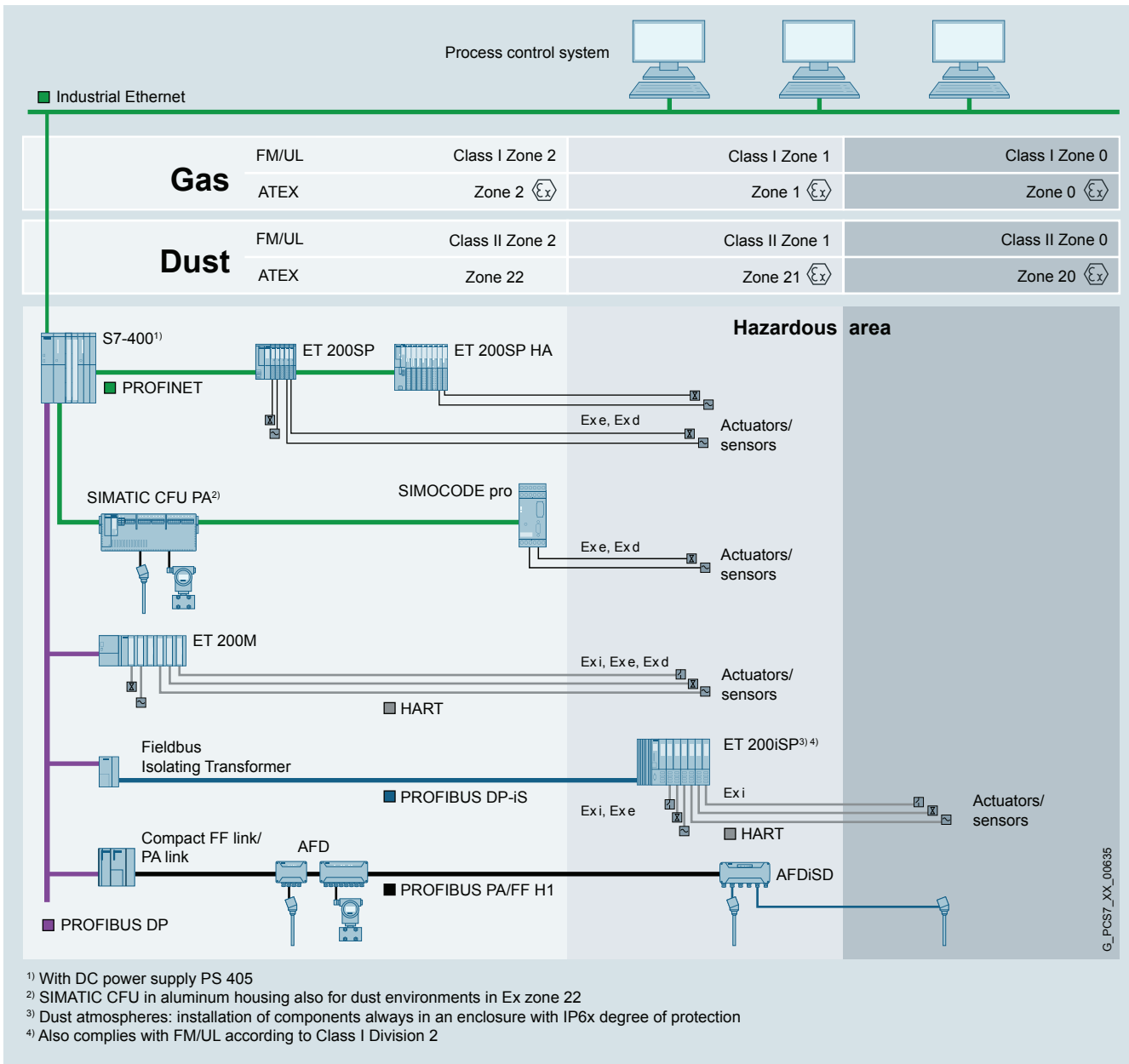

Process I/O in hazardous gas and dust atmospheres

**Field devices on the PROFIBUS PA fieldbus or FOUNDATION Fieldbus H1**

Field devices located in Ex zones 0, 1, 2, 20, 21 or 22 can be integrated in SIMATIC PCS 7 via various active field distributors on the PROFIBUS PA or FOUNDATION Fieldbus H1. The active field distributor AFDiSD is required for this purpose for field devices in Ex zones 0, 1, 20 or 21.

**SIMATIC ET 200M and SIMATIC ET 200SP**

ET 200M and ET 200SP remote I/O stations can be used in Ex zone 2 or 22 as well as in non-hazardous areas. The actuators/sensors can also be positioned in Ex zone 1 or 21. Special Ex I/O modules are available for this in the ET 200M product range.

**SIMATIC ET 200SP HA and SIMATIC CFU**

ET 200SP HA and CFU are designed for use in the control cabinet and also allow installation in hazardous areas up to Ex zone 2-22.

**ET 200iSP**

ET 200iSP remote I/O stations suitable for gas/dust atmospheres can be installed directly in Ex zones 1, 2, 21 or 22 as well as in non-hazardous areas. The intrinsically-safe sensors, actuators and HART field devices can also be located in zone 0 or 20 if necessary.

**SIMATIC ET 200pro**

ET 200pro remote I/O stations are designed for use in non-hazardous areas.

## SIMATIC ET 200SP HA – The optimal basis for the digital challenges of the process industry



SIMATIC ET 200SP HA: Depending on the application, the distributed I/O can be operated redundantly with two interface modules or as a single station with one interface module.

Enclosed space in a plant is in short supply and cost-intensive. The compact, modular SIMATIC ET 200SP HA I/O creates space in the control cabinet – that saves costs associated with enclosed space, air conditioning and the energy demand of I/Os in the control cabinet. Its highly scalable configuration enables the control cabinet to be sized exactly to the actual requirements. Its new design allows up to 56 I/O modules per station to be used. An especially high channel density of up to 32 channels on a module that is only 22.5 cm wide ensures maximum economy in the control cabinet.

The high-performance SIMATIC ET 200SP HA maximizes availability through redundant PROFINET connections. These allow the connection to high-availability controllers via two independent networks with a choice of copper or fiber-optic cables. The system can be scaled and extended in small steps using a variety of available modules, for example, with digital and analog I/Os as well as NAMUR, HART and other protocols.

All 24 V standard signals are connected via an identical terminal block type, which allows a high degree of standardization for the control cabinets. And, the tool-free connection system with push-in terminals and permanent wiring lowers the effort for engineering, installation and cabling.

Other advantages are "Change in Run" (CiR) through redundant design and increase of the module count on the head station from 12 to 56. The SIMATIC ET 200SP HA is designed for use in the control cabinet as well as for hazardous areas up to Ex zone 2. The extended temperature range from -40 to +70 °C and the conformal coating of all components allow direct installation in the field.

### SIMATIC ET 200SP HA at a glance

- Compact I/O modules
  - Up to 32 channels on a module that is 22.5 mm wide
  - Up to 56 modules per station
- Perfectly suited for applications in the field
  - Installation in hazardous areas up to Ex zone 2-22
  - Extended temperature range: -40 to +70 °C
  - Enhanced interference immunity in accordance with NAMUR recommendation NE21
  - Conformal coating on all components
  - Can be used at altitudes of up to 4 000 meters
- Wide range of supported module types
  - 16×AI/8×AO HART, 16×DI, 16×DO etc.
- Standard I/O terminal block
  - For all 24 V signals AI, AO, DI, DO



# SIMATIC CFU - The Compact Field Unit

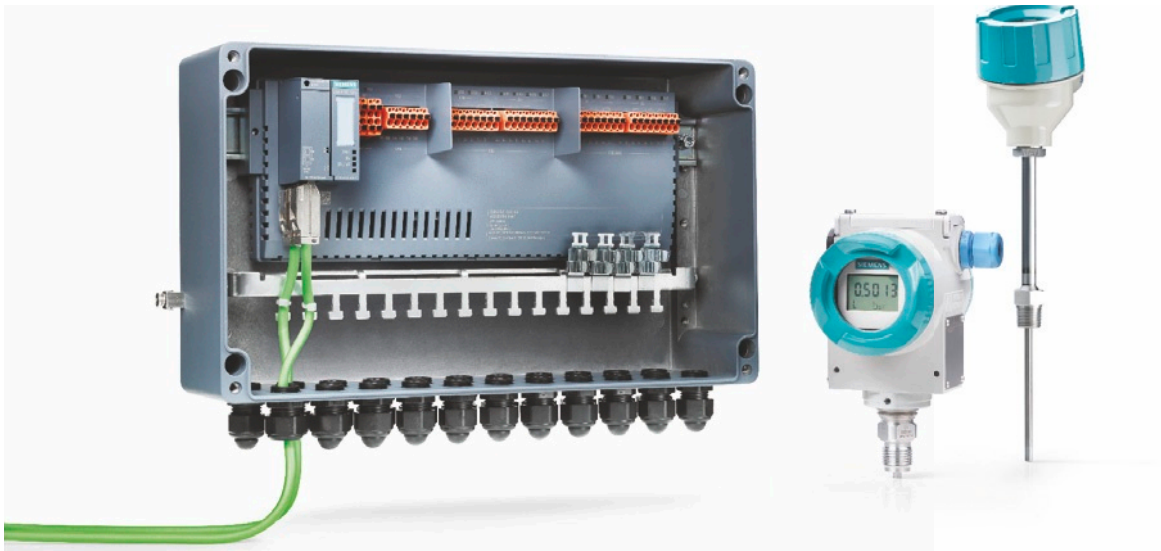

## Are you ready for a change in perspective in the field?

Digitalization provides an important impulse for the process industry, as well. You can benefit from even more flexibility and easier handling coupled with maximum availability. With our new approach to field device connection, the SIMATIC CFU makes it possible for you to transfer your conventional system concept into the digital world.

The new SIMATIC CFU is a real game changer in field device connection and offers you entirely new prospects regarding simplicity and flexibility. This compact field distributor, which is installed in the vicinity of the process, is directly connected to the process control system via PROFINET and forms the foundation for digitalization in the field. Through the use of digital fieldbus communication, the field device connection becomes much simpler than with conventional 4 to 20 mA technology .

## Simpler thanks to plug-and-produce

Digitalization requires integrated digital communication down to the sensor and actuator. You make use of the established PROFIBUS PA standard for this purpose. This has been implemented in the PA Edition of the SIMATIC CFU, thus combining ruggedness and easy handling with the advantages of the Industrial Ethernet-based PROFINET standard. Connected devices are addressed automatically, and the device is integrated very simply via standardized communication profiles.

This innovative new implementation of the PROFIBUS PA concept makes it possible to combine the simplicity of a point-to-point wiring system with the scalability of digital PROFIBUS PA fieldbus communication. As with digital field devices, it is not necessary to know prior to connection whether the discrete field device is a sensor or actuator. This can be easily configured afterwards with software.

## Greater flexibility thanks to consistent decentralization

The decentralized installation of the SIMATIC CFU makes traditional control cabinets dispensable. A significant reduction in cables and terminal points and less effort for planning and documentation are the advantage. The high granularity (16 I/O per SIMATIC CFU) enables flexible assignment to the higher-level controllers.

### SIMATIC CFU at a glance

- Simpler thanks to plug-and-produce
  - Fast and reliable device integration
  - Easy and reliable device replacement without intervention in the engineering system



**This makes device integration easy and reliable, and the time required is reduced from half an hour or more to less than a minute.**

- Greater flexibility thanks to consistent decentralization
  - No more individualized control cabinets
  - Reduction in marshalling and cabling effort
  - Less effort for planning and documentation
  - Standardized mounting technology – no hardware FAT required
  - Parallelization of project processes
  - Flexible plant expansion without the need to maintain reserves
  - Reduction of installation effort, complexity and maintenance costs

**Up to 70% fewer terminal points and 30% or more reduction in cabling costs**

## Drives

### Recommended devices

Drives	SIMOCODE pro	SINAMICS G120
	 <p>Motor management system for constant-speed motors in the low-voltage range</p>	 <p>Frequency converters for Three-phase synchronous motors and three-phase asynchronous motors</p>
Degree of protection	IP20 (module-dependent)	IP20
Model	Modular	Modular (control unit, power unit)
Performance range	0.1 ... 700 kW	0.37 ... 250 kW
Voltages	Up to 690 V AC	380 ... 480 V or 660 ... 690 V AC $\pm$ 10 %
Rated motor currents	Up to 820 A	–
PROFIBUS communications	●	●
Block library for SIMATIC PCS 7 integration	●	●
Application	<p>Protection and control of motors</p> <ul style="list-style-type: none"> <li>■ In hazardous areas for types of protection EEx e/d corresponding to ATEX directive 94/9/EC</li> <li>■ With heavy-duty starting (paper, cement, metal and water industries)</li> <li>■ In high-availability plants (chemical, oil, raw material processing industry, power plants)</li> </ul>	For universal use in all industrial and trade sectors

## Sensors/actuators, analyzers, weighing and dosing systems

Siemens offers a comprehensive range of devices for operation with the SIMATIC PCS 7 process control system, for example

- Devices for measurement of pressure, flow, temperature or level
- Positioners
- Gas analyzers
- SIWAREX weighing systems

This includes versions with PROFIBUS DP/PA interface and for HART communication. The majority of devices is already included in the device library of the SIMATIC PDM process device manager.

Overview of the current range of devices with additional information, technical specifications and ordering data:

[www.siemens.com/processinstrumentation](http://www.siemens.com/processinstrumentation)  
[www.siemens.com/processanalytics](http://www.siemens.com/processanalytics)



Device range of Siemens process instrumentation and process analytics (selection)

# Batch automation with SIMATIC BATCH

Modular, flexible, scalable and fully integrated in SIMATIC PCS 7



SIMATIC BATCH's recipe-driven control strategies enable efficient and flexible execution of simple and complex batch processes with changing control sequences. SIMATIC BATCH meets all the associated high requirements without exception:

- Optimum capacity utilization of production plants
- Uniform product quality
- Traceability
- Compliance with statutory standards and directives
- Fast response to changing market conditions
- Modular architecture

SIMATIC BATCH can be configured either as a single-station system or as a client/server system. Thanks to its modular architecture and scalable unit instances (UNITs), the plant size can be flexibly adapted to project-specific requirements.

For small batch applications, a SIMATIC PCS 7 BOX can be combined with a separate controller, for example, a SIMATIC PCS 7 AS RTX.

However, characteristic for the automation of batch processes using SIMATIC BATCH are client/server architectures with which one batch server and several Batch Clients process a plant project together. The batch server can also be configured with redundancy in order to increase availability.

In addition to the SIMATIC PCS 7 Industrial Workstations, the more compact SIMATIC PCS 7 OS clients 627D and 427D/477D are also suitable for use as batch clients.

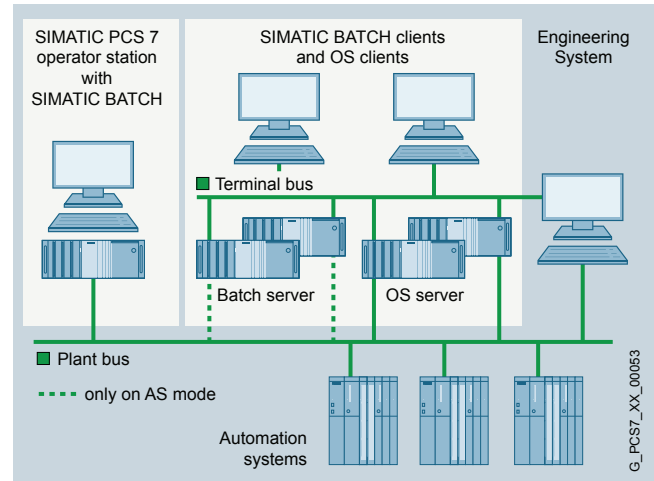

SIMATIC BATCH, scalable from single-user up to client/server system

## Integration in SIMATIC PCS 7

SIMATIC BATCH is fully integrated in SIMATIC PCS 7. The plant data can be completely configured using the engineering system and all data required for recipe creation transferred to SIMATIC BATCH. This makes it possible to edit recipes separate from the engineering system. Changes to the configuration on the engineering system are available to SIMATIC BATCH using an update function.

SIMATIC BATCH usually runs on dedicated hardware, separate from the operator system. Depending on the load, however, the operator system and SIMATIC BATCH can share the hardware.

SIMATIC BATCH provides special faceplates and OS controls for controlling and monitoring units and equipment phases. Instances of an SFC type are typically used as the interface to the lower automation level.

SIMATIC BATCH uses SIMATIC Logon integrated in the process control system for:

- Central user administration and authentication
- Release of basic recipes, formulas and library objects using an "electronic signature"

Individual configuration settings of the Batch Control Center and recipe editor are saved as a user-specific profile when logging off. The next time you log on, the usual environment is therefore available once again.

### Operating modes for recipe processing

- PC mode: execution of complete recipe logic in the batch server
- AS mode: execution of unit recipe logic in the automation system:
  - Very fast step changing times
  - Improved determinism during batch processing
  - Enhanced availability
- Mixed mode: parallel application of PC and AS modes in one batch

### Application Programming Interface (API)

The SIMATIC BATCH API Application Programming Interface is an open interface for customer-specific extensions. To program special industry-specific or project-specific applications it offers the user access to data and the functions of SIMATIC BATCH.



### SIMATIC BATCH at a glance

- Modular architecture with flexible scalability (hardware and software)
  - Optimum scaling to plant size and individual requirements
  - Grows with the plant configuration; no expensive spare capacities
- High availability thanks to redundant batch servers
  - No loss of production and batch data
  - Automatic synchronization of batch data
- High availability, improved deterministic and fast step transitions when executing the recipe logic in the automation system
- Homogeneous integration of SIMATIC BATCH into the HMI strategy and the engineering of SIMATIC PCS 7 via system interface
  - No customized interfaces
  - No double configuring for batch-specific engineering data
  - Reliable operator prompting, safe response to process faults
  - OS Controls for integration in process displays
  - Operator control of the OS Controls via a Web client
- Recipes independent of unit
  - Considerable simplification in recipe management and validation
  - Flexible control strategy and optimum plant utilization through allocation strategies and assignment of units during batch runtime
- Hierarchical recipes according to ISA-88.01
  - Creation of recipes oriented according to process engineering
  - Quick, easy and fault-minimizing creation
- Logging of recipes and batch data
- Importing and exporting of master recipes, formulas and library objects
- Storage of batch data and archiving, for example, in the Process Historian
  - Production becomes transparent and comprehensible
  - Viewer for archived batches
- Reduction in engineering and validation overhead through:
  - Type/instance concept of SFC
  - Separation of procedure and formula
  - ROP library and configuration independent of unit
  - Multiple uses, central modification
- Validation support according to 21 CFR Part 11 through:
  - Audit Trail (change log)
  - Free and system-aided versioning
  - Libraries with recipe operations and formulas
  - User administration with access protection and electronic signature



# Planning and operation of batch processes

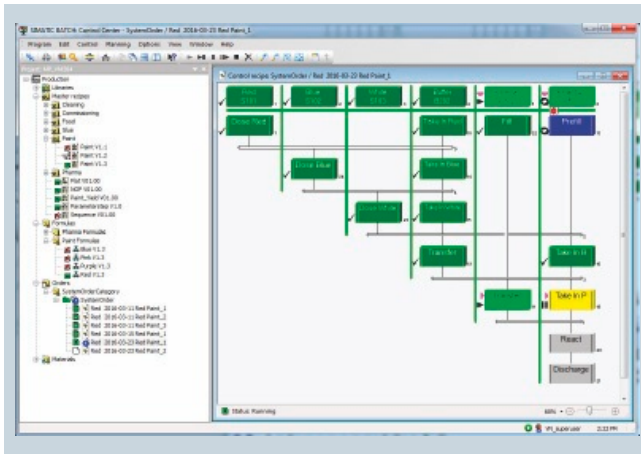

Batch Control Center

## Batch Control Center

The Batch Control Center (BatchCC) offers high-performance functions for operating batch processes as well as for managing recipes and batch data. The operator can use it for such tasks as:

- Reading in and updating the process cell data of the basic automation
- Defining user rights
- Defining material names and codes
- Managing master recipes and libraries with recipe elements (library operations)
- Editing formula categories and managing associated formulas (parameter sets)
- Creating master recipes from control recipes
- Exporting and importing of master recipes, formulas and library objects
- Creating production orders and batches with master recipes
- Starting batch processing, monitoring, diagnostics and controlling batches
- Define allocation strategies and assigning units to batch runtime
- Changing, deleting and re-inserting objects and structural elements of the recipe online
- Recording and archiving of recipes and batch data
  - Recipe reports with production data
  - Batch reports with data for reproducing the batch process as well as for verification (quality, legal requirements)
- Displaying archived batches as control recipes
- Calling SFC Visualization from the control recipe

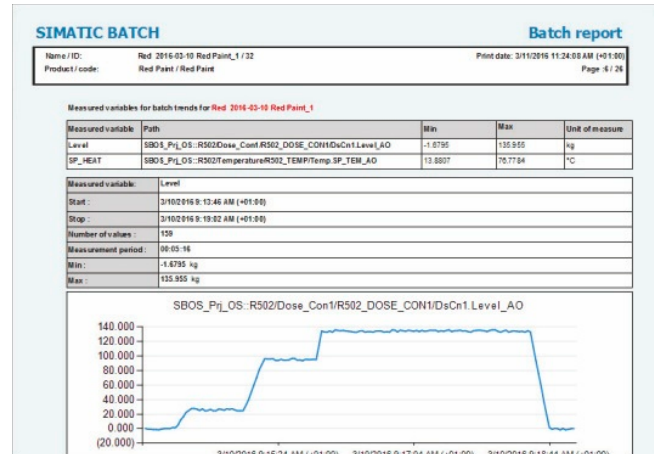

Example of a batch report

## Batch OS Control

The Batch OS controls that can be shown in the process picture can be a practical alternative to BatchCC for the operator, for example:

- Unit overview
- Overview of recipe operations (ROP)
- Batch creation
- Job and batch overview
- Batch operation and monitoring
- Operator control via Web client possible

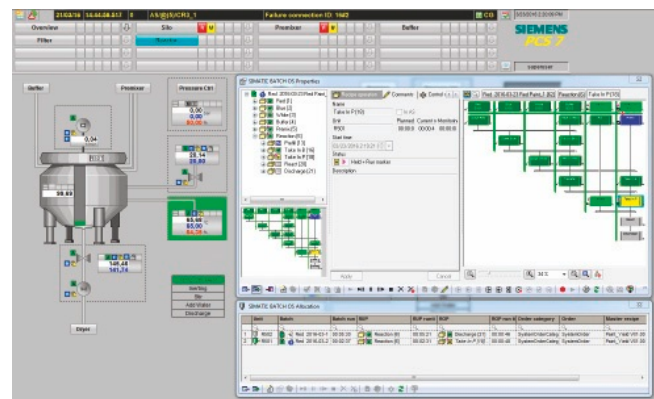

Process picture including Batch OS Control

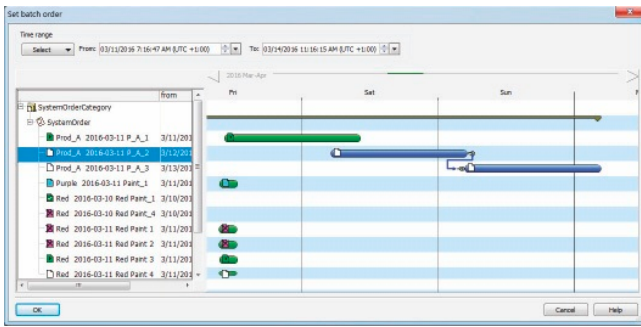

Batch planning

### Batch planning

BatchCC can be used to create production orders and batches individually. However, Batch Planning offers significantly more planning functions. Batches for a large number of production orders can then be planned in advance.

All batches including their unit allocation can be clearly presented in a combination of Gantt diagram and table. Time conflicts or those resulting from duplicate allocation of units are identified by symbols. Time conflicts can be eliminated simply by shifting the associated batches in the Gantt diagram. In addition to planning, the scope of functions include the modification, cancellation, deletion and release of batches. The following batch properties can be set and changed:

- Quantity
- Start mode (immediately, following operator input or time-driven)
- Unit allocation
- Formula parameters
- Run sequence (chaining to previous or subsequent batch)
- Display of planned runtime for a batch
- Definition of minimum time interval for batch chaining

## Recipe creation and editing

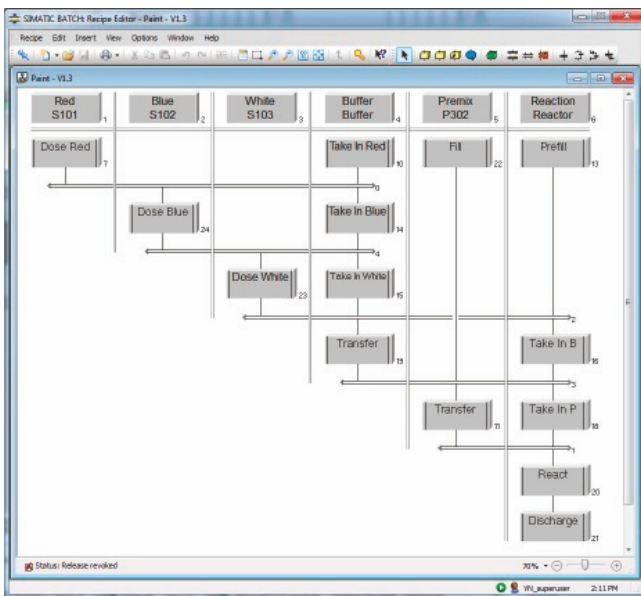

SIMATIC BATCH Recipe Editor

Master recipes and library operations can be created and modified with the Recipe Editor easily and intuitively. It features a GUI for this, processing functions for individual and grouped objects and a structural syntax check.

Additional functions in this context:

- Querying the states of recipe objects and process values in transition conditions
- Sending products of a batch with route control locations as transfer parameters (source, target, via) to other units (local or external plants)
- Configuring arithmetic expressions for calculating setpoints for transition and recipe parameters
- Documenting master recipes and library operations
- Checking plausibility
- Selecting appropriate units using static equipment properties and dynamic attributes
- Releasing master recipes and library operations for testing or production

The process states of freely selectable recipe sections can be monitored during runtime. It is possible to react to evaluated events or faults using a command block or jump function in a special container.



## Rationalization of recipe creation

### Hierarchical recipes with recipe operations from a library

The structure of hierarchical recipes is mapped to the plant model according to ISA-88.01: Recipe procedure in a plant, recipe unit procedure in a plant and recipe operation/recipe function in an equipment module.

References can be used in the recipe procedures of hierarchical recipes that refer to recipe operations in a user library (ROP library). Central changes to the recipe operations of the library affect all its associated references. This reduces the effort for engineering and validation.

If the reference link is broken, the recipe operation becomes a fixed component of the recipe procedure, and is thus independent of further central modifications.

### Unit neutrality and unit assignment

Creation of recipes that are not bound to a specific unit minimizes the engineering overhead and provides significant advantages for validation. During creation of the recipe, the recipe unit procedures are only assigned selection criteria. The final assignment of the units following evaluation of the static and dynamic properties (e.g. vessel size and cleaning status) is then carried out during runtime. In the cases of batches which run for a longer period and where the units are not to be already determined and occupied at the start of a batch, the assignment is only carried out at the time of use. Conflicts in the unit allocation are detected by the system and displayed.

### Separation of procedure and formula

The flexibility achieved by recipes which are independent of specific units can be increased even further if the procedure and formulas are separated from one another. Various master recipes can be created by linking several formulas using a recipe procedure. This enables central modification of procedures.

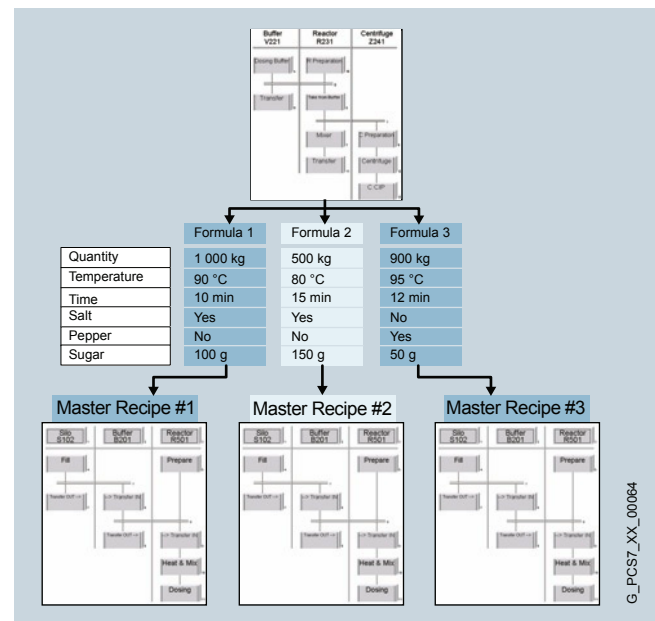

Separation of procedure and formula

For additional information on SIMATIC BATCH, see:  
[www.siemens.com/simatic-batch](http://www.siemens.com/simatic-batch)

# Route Control with SIMATIC Route Control

## SIMATIC PCS 7 rationalizes material transport



SIMATIC Route Control (RC) expands the SIMATIC PCS 7 process control system with a sector-independent tool for the configuration, control, monitoring and diagnostics of material transport in pipeline networks or on conveyor belts. Thus SIMATIC PCS 7 is capable of automating not only production processes and associated warehouses but also the material transport linking both areas.

SIMATIC Route Control is suitable for small plants with simple, static transport routes or also for plants in the medium and top performance ranges possessing comprehensive, complex routes and pipeline networks.

SIMATIC Route Control is particularly predestined for the following requirements:

- Frequent conversions and extensions of the transport network including actuators and sensors
- Transport routes with high flexibility, characterized by:
  - Regularly changing materials
  - Dynamic selection of the origin and destination of the material transport
- Numerous simultaneous material transports
- Dynamic allocation of units using SIMATIC BATCH

This requirement profile particularly applies to plants with numerous branched pipelines or comprehensive tank farms typical for the chemical, petrochemical or food and beverage industries.

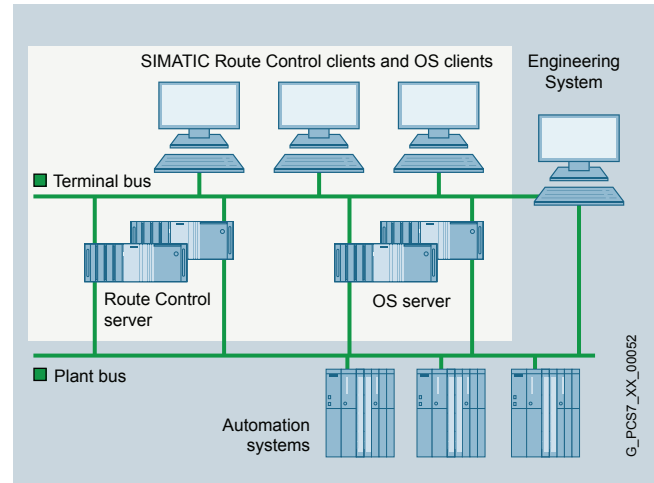

SIMATIC PCS 7 multiple station system with SIMATIC Route Control

### Modular architecture

Thanks to its modularity and discrete scalability with cumulative SIMATIC Route Control (quantity options for simultaneously active material transports), SIMATIC Route Control can be flexibly adapted to different plant sizes and architectures (single-station / multiple station systems) up to the project upper limit of 300 routes.

### Integration in SIMATIC PCS 7

For small plants, SIMATIC Route Control can be installed either alone or together with the OS software on a single station system. However, distributed multiple station systems with client-server architecture are more typical for the automation of material transports with SIMATIC Route Control.

A Route Control server or server pair is configured in a SIMATIC PCS 7 multiple station system consisting of one or more subsystems. In the case of multiple station systems with small quantity frameworks it is also possible to operate the Route Control Server, Batch Server and OS Server on shared basic hardware. However, availability will be higher and performance better if the subsystems are installed on separate servers or redundant pairs of servers.



In the mimic diagram of the SIMATIC PCS 7 operator system, each route block is represented by an RC block symbol and an RC faceplate. Locations are parameters for requesting a material transport They mark the start and end of each partial route and thus also the source and destination of a material transport.

The Route Control engineering software consisting of the engineering tool, wizard and block library is integrated in the SIMATIC PCS 7 Engineering System.

SIMATIC Logon, which is integrated in the process control system, is used for access control and managing the graded user rights for engineering, operating and maintenance personnel.

### Route Control Center (RCC)

The Route Control Center (RCC) is a synonym for the Route Control client. It can be installed on an OS client, a batch client or separate client hardware. It displays all route data and error information relevant to material transport in several coordinated views.

### Route Control Server

After the configuration of the route network and testing the material handling variants, the Route Control configuration data are transferred to the Route Control Server (RC Server). They can then be activated at a point in time suitable from the perspective of the technical process. The activated data are included in the route search.

The RC server supplies the RC clients with the necessary data and forwards their commands to the automation systems.

If a material transport is waiting, a route is requested either via the controller or by the operator at the RCC. Apart from specifying the source, destination and up to 10 optional plant locations (intermediate points), this also includes creating a start signal on the route control block of the automation system.

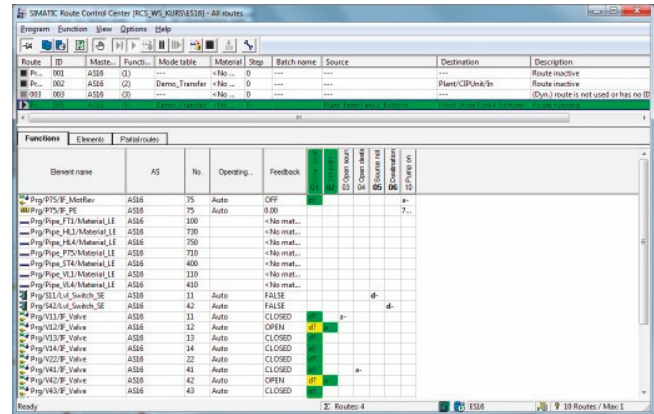

Route Control Center (RCC)

If no saved route is available, the RC Server starts the route search and, if possible, combines the statically defined partial routes into one complete transport route. From there on, Route Control takes over the control and monitoring of all RC elements involved in the transport route. The process cell control only has to switch the individual technological functions. When errors occur, the operator receives detailed diagnostics information about the cause, e.g. why the search for a transport route failed.

For maintenance purposes, an automation system can be specifically set to "in maintenance" (out of service). The material transports operating via this automation system are then completed, but no more new ones are permitted.

WAIT elements allow delayed (cascaded) control of the on/off sequence for actuators, for example, during transport of solid materials on conveyor belts. When liquids are transported in pipes, the order and the time intervals for cleaning the valves with pulsing are also adjustable with WAIT elements.

## Route Control engineering

The Route Control configuration supplements the basic configuration with blocks from the SIMATIC PCS 7 library. To this end, the catalog of the CFC editor contains a Route Control library with blocks for RC configuration and for configuring transport routes and interface blocks for RC elements.

Technological elements of relevance to control of material transport (RC elements) are adapted in the CFC editor using uniform interface blocks from the Route Control library. The RC elements include:

- Control elements (actuators)
- Sensor elements (sensors)
- Parameter elements (setpoints)
- Connection elements (material information related to partial route)
- WAIT elements

The locations of partial or complete routes configured in the SIMATIC Manager as "Equipment properties of units" are entered in the RC project together with the other RC-relevant basic data of the SIMATIC PCS 7 project.

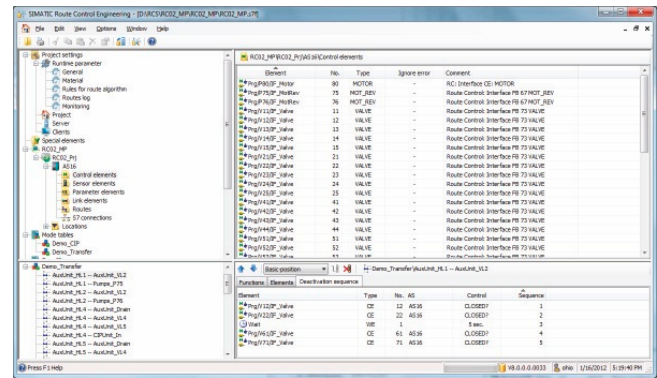

Configuration with the Route Control engineering tool

The RC-specific objects then have to be configured:

- Dividing the transport routes into flexible partial routes ("Priority" and "Bidirectional" parameters)
- Interconnection of RC elements by installing them in a partial route
- Assigning technological sequence functions
- Assignment of the partial routes to a function catalog, e.g. "Cleaning"

Generic elements can be used to integrate user-specific objects or blocks into the RC project and handle them like RC elements.



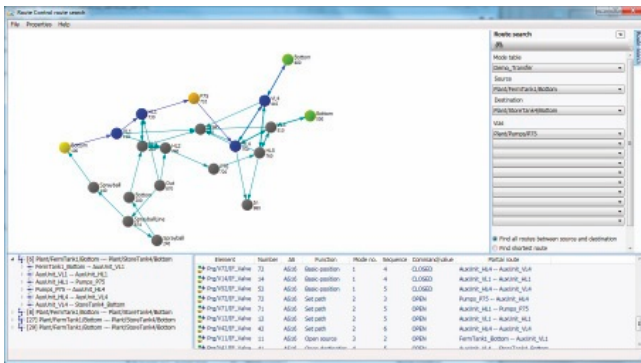

Graphical offline route search to determine all possible route combinations

Similarly to a navigation system, the graphically visualized offline route search determines all possible route combinations. In this way, errors in the route network or undesired routes can be detected in advance.

A preferred route can be selected from the results of the offline route search and saved as a static route. An active route can be saved for re-use via the Route Control Center. A saved route is given priority in a route request.

Special configuration functions make it easier to perform repetitive routine work and extend the range of options for controlling material transport, e.g.:

- Exporting configuration data in the form of CSV files to Microsoft Excel, copying and editing the data there and then re-importing the files into Route Control
- Controlling the joint use of partial routes by configurable function IDs
- Checking of material compatibilities by evaluating the partial route material IDs and interlocking of partial routes in the case of incompatible material sequences
- Connecting setpoints arriving from the process (e.g. weighed quantity) to the route block in runtime

For additional information, see:

[www.siemens.com/simatic-pcs7/routecontrol](http://www.siemens.com/simatic-pcs7/routecontrol)

## SIMATIC Route Control at a glance

- Flexible, modular and scalable architecture for single-user and multiple station systems
  - Optimum adaptability to plant size and individual requirements
  - No expensive reserve capacities
  - High availability thanks to redundant Route Control Servers
- Homogeneous integration into the HMI strategy and the engineering of SIMATIC PCS 7
- Can be combined with SIMATIC BATCH – Material transports from a batch control recipe
- Mapping of route network of the plant through partial routes
- Fast response to plant modifications during configuration, commissioning or runtime
- Exclusive assignment of RC elements and partial routes involved in material transport
- Reduction in configuration overhead and commissioning times
  - Configuring partial routes by means of repeated application
  - Data export to Microsoft Excel and re-importing
  - Reduction in complex, repeated tasks through RC wizard
  - Graphical offline route search determines all route combinations in advance and finds undesired routes
- Consideration of material compatibilities to avoid undesired mixing
- Offline testing for completeness, inconsistencies and undesired combinations
- Detailed diagnostics of material transport requirement faults and current material transport
- Saved static routes are executed with priority when a route is requested
- Definition of on/off switching sequences using staggered control of actuators, e.g. for conveyor belts



# Safety Integrated for Process Automation

Comprehensive range of products and services for process safety



The process industry frequently features complex production sequences where materials and mixtures which are explosive or dangerous to health are produced or processed. A fault or failure could have disastrous consequences.

Therefore the objective of Siemens safety technology is to minimize potential hazards for personnel, plant and environment by means of technical measures, without adversely affecting the production process. A reliable Safety Instrumented System (SIS) is therefore required which is able to automatically place the plant into a safe state should critical events occur, to continue operating it safely under defined conditions and to limit any negative effects in the event of a safety-related event.

Safety Integrated for Process Automation provides a comprehensive range of products and services for safe, fault-tolerant applications in the process industry – based on the Siemens safety-related system. It offers complete safety-related functionality – extending from safe instrumentation for signal recording and conversion, to safe and fault-tolerant control, up to the actuator (e.g. positioner, valve or pump).

The enormous potential of Safety Integrated for Process Automation can best be exploited in conjunction with SIMATIC PCS 7. Thanks to the modularity and the flexibility of the safety-related products this combination is extremely variable. It is not just the degree of integration of safety-related systems that can be individually defined in the process control system, it is also the degree of redundancy for controllers, fieldbus and process I/O (Flexible Modular Redundancy). Thanks to the reduced spatial requirements, the scope of hardware and wiring, as well as reduced mounting, installation and engineering overhead, complete integration of the safety-relevant systems in SIMATIC PCS 7 offers the greatest cost advantages viewed over the entire lifecycle of a plant.

Both the safety technology and the safety applications implemented with it are characterized by great efficiency and comply with both national and international standards, such as:

- IEC 61508 – basic standard for specifications, as well as for the design and operation of safety-related systems
- IEC 61511 – application-specific standard for the process industry



# Product range

Safety Integrated for Process Automation – product spectrum for SIMATIC PCS 7		
	<b>Engineering</b>	Configuration of safety functions (up to SIL 3) using TÜV-certified function blocks and Continuous Function Chart (CFC) or SIMATIC Safety Matrix (cause&effect matrix)
	<b>Automation systems on PROFIBUS or PROFINET</b>	Fail-safe, fault-tolerant controllers with a redundant or non-redundant design (SIL 3) for the bottom, mid and top performance ranges
	<b>PROFIsafe with PROFIBUS PROFIsafe with PROFINET</b>	For standard and safety-related communication on just one bus cable, certified according to IEC 61508 (SIL 3)
	<b>SIMATIC ET 200</b>	<p>ET 200M: Modular I/Os for high density applications with safety-related signal modules F-DI 12/24 × DC 24 V, F-DI 4/8 × NAMUR [Ex ib], F-DO 10 × DC 24 V/2 A, F-DO 8 × DC 24 V/2 A, F-AI 3/6 × 0 ... 20 mA or 4 ... 20 mA (HART), SIL 2/SIL 3; IP20 degree of protection</p> <p>ET 200iSP: Modular, intrinsically-safe I/O with safety-related electronic modules F-DI Ex 4/8 × NAMUR, F-DO Ex 4 × DC 17.4 V/40 mA, F-AI Ex HART 4 × 0 ... 20 mA or 4 ... 20 mA, SIL 3, IP30 degree of protection</p> <p>ET 200S: Bit-modular I/O with safety-related electronic modules F-DI 4/8 × DC 24 V, F-DO 4 × DC 24 V/2 A and safety-related motor starters; SIL 2/SIL 3, IP20 degree of protection</p> <p>ET 200pro: Modular, very compact I/O with safety-related electronic modules F-DI 8/16 × DC 24 V, F-DI/DO 4/8 × DC 24 V (DI) and 4 × DC 24 V/2 A (DO); SIL 2/SIL 3; F-switch for switch-off of standard I/O and control of motor switches; IP65/66/67 degree of protection</p>
	<b>Process instruments, Drives</b>	<p>Safe process instruments on PROFIBUS: Pressure transmitter SITRANS P DS III PA (SIL 2) with PROFIsafe, SIMOCODE pro with DM-F local/PROFIsafe (SIL 3), SIPART PS2 PA (SIL 2)</p> <p>Safe process instruments/devices for connection to ET 200M remote I/Os: SITRANS P DS III analog/HART (SIL 2), SITRANS TW Series (SIL 1), SITRANS TH200/300 (SIL 2), SITRANS TR200/300 (SIL 2), SITRANS LVL200 (SIL 2), SITRANS LR250 HART (SIL 2), SITRANS FC430 (SIL 2), SIPART PS2 2/4-wire (SIL 2)</p> <p>SINAMICS drives with fail-safe function</p>
	<b>Applications</b>	Partial stroke test Pre-defined function blocks and faceplates for online valve test for preventive valve diagnostics without interfering with production

# Safety-related design versions

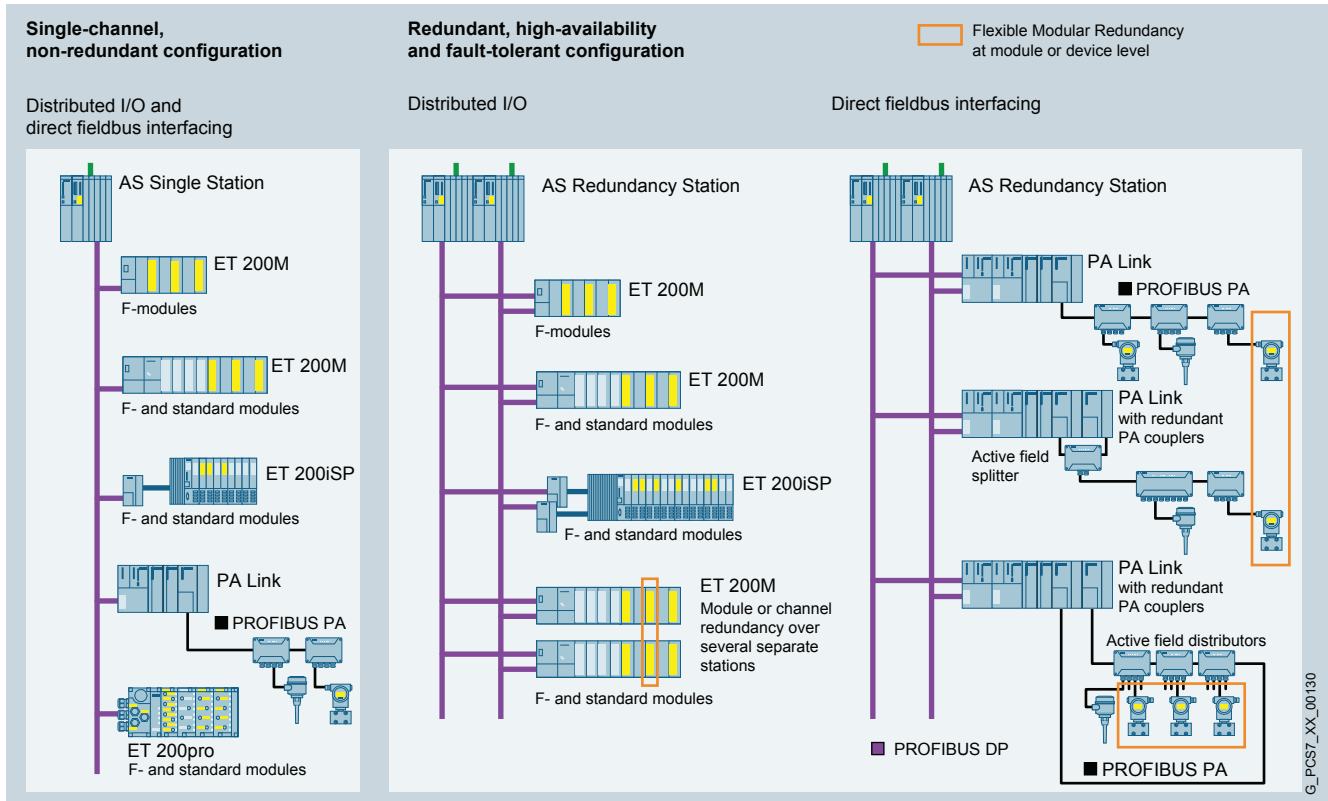

Safety-related design versions with PROFIBUS communication

The PROFIsafe profile allows safety-related communication for between the controller and the process I/O via the open standard buses PROFIBUS and PROFINET. PROFIsafe expands the frames by additional information with which the PROFIsafe communications partners can recognize and compensate transmission errors such as delays, incorrect sequences, repetitions, losses, addressing errors or data falsification.

Since PROFIsafe is implemented as an additional software layer within the devices/systems without modifying the standard communication mechanisms, standard components and safety components can operate on the same bus. This makes a separate and expensive safety bus unnecessary.

However, the decision between PROFIBUS or PROFINET has seriously affects the architecture of the safety engineering system.

## Safety-related design versions with PROFIBUS

In the case of a safety-related system with PROFIBUS communication integrated into SIMATIC PCS 7, a distinction is made across all architecture levels between two design versions:

- Single-channel, non-redundant design
- Redundant, high availability and fault-tolerant design

Both alternatives are extremely variable and offer generous scope for design. At the individual architectural levels (controller, fieldbus, distributed I/O), the configuration options shown in the diagram are available depending on the process I/O used.

Standard (basic process control) and safety-related functions can be combined flexibly, not only in the area of the distributed I/O. Even at the controller level, they can be combined in one system or separate. In addition, there are numerous possibilities using flexible modular redundancy (FMR).

## Flexible Modular Redundancy (FMR)

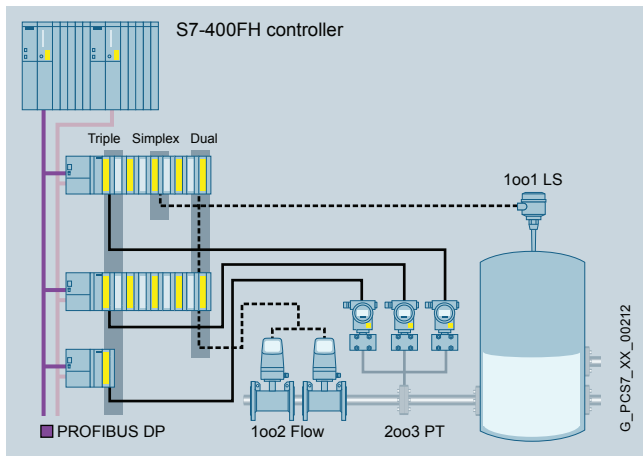

Flexible Modular Redundancy using the example of a safety-oriented, fault-tolerant plant configuration

Depending on the automation task and the associated safety requirements, the degree of redundancy may be defined separately for the controller, fieldbus and distributed I/O level and coordinated with the field instrumentation. In this way, individual fault-tolerant architectures which are precisely tailored to the individual tasks can be implemented and tolerate several faults occurring at once. As FMR provides redundancy only where it is actually required, comparatively more attractive and cost-effective applications are possible than with conventional redundancy architectures.

As shown in the example of a process cell with ET 200M distributed I/O, the total of the tasks can produce a mix of different degrees of redundancy within one architecture level (1001, 1002, 2003).

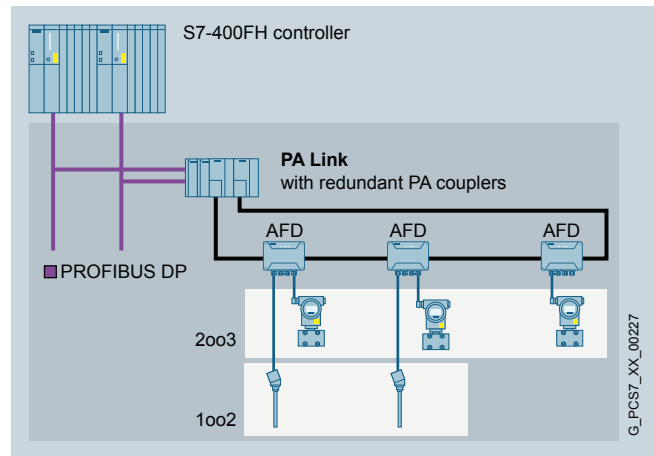

Safety-related and fault-tolerant architecture based on a PROFIBUS PA ring architecture

Not only can FMR be applied to plant configurations with distributed I/O systems, but it can also be transferred to configurations with direct connection of devices via the PROFIBUS PA fieldbus. As shown in the example, the PROFIBUS PA ring architecture likewise permits cost-effective, safety-related and fault-tolerant applications with minimum use of devices and cables.

AFD active field distributors can be used in operating environments up to Ex Zone 2/22 and AFDiS active field distributors in operating environments up to Ex Zone 1/21. AFD active field distributors integrate field devices allocated to the same hazardous area over spur lines. The spur lines of AFDiS can be laid up to zone 0/20 for connecting suitable devices.

## Safety-related design versions with PROFINET

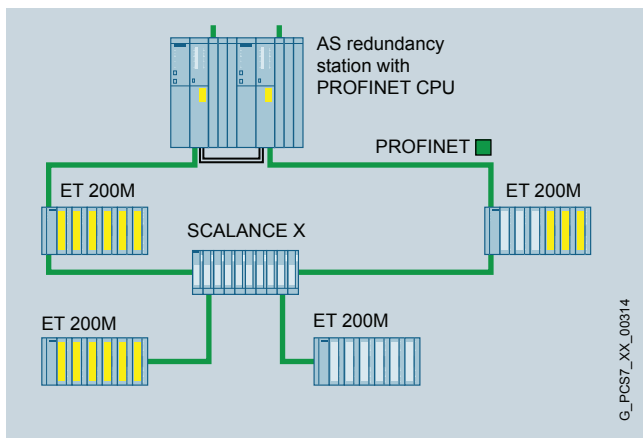

Safety-related design versions with AS redundancy station and PROFINET IO communication

PROFINET supports safety-related systems on the basis of safety-related SIMATIC PCS 7 automation systems (F/FH) and ET 200M remote I/Os. With a safety-related system with PROFINET communication, the ring is the topology of choice from the point of view of availability. The media redundancy of the ring means that bus interruptions or failure of a node will not result in failure of the entire segment.

The maximum availability level is achieved with a PROFINET ring on a redundant controller (AS Redundancy Station). In such a configuration, the structure of PROFINET IO communication referred to as system redundancy enables the I/O devices to establish a communication connection to each CPU of the AS Redundancy Station over the topological network.

# Engineering tools for safety functions

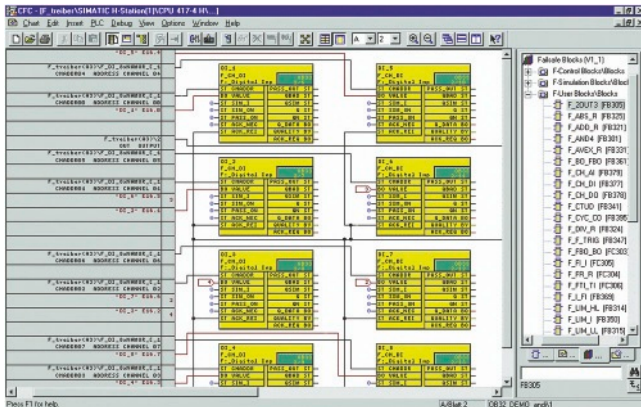

Engineering of safety-related applications using CFC

The F block library in S7 F systems and the SIMATIC Safety Matrix are available for configuring and programming safety-related controllers.

## S7 F systems with F block library

The S7 F Systems engineering tool permits parameterization of safety-related controllers as well as safety-related F-modules of the ET 200 series. It supports configuration by means of functions for:

- Comparison of safety-related F-programs
- Recognition of changes in the F-program using the checksum
- Separation of safety-related and standard functions.

Access to the F-functions can be password-protected.

The F block library integrated in S7 F Systems contains predefined function blocks for generation of safety-related applications with the CFC or the Safety Matrix based on it. The certified F-blocks are extremely rugged and intercept programming errors such as division by zero or out-of-range values. Diverse programming tasks for detecting and reacting to errors can thus be omitted.

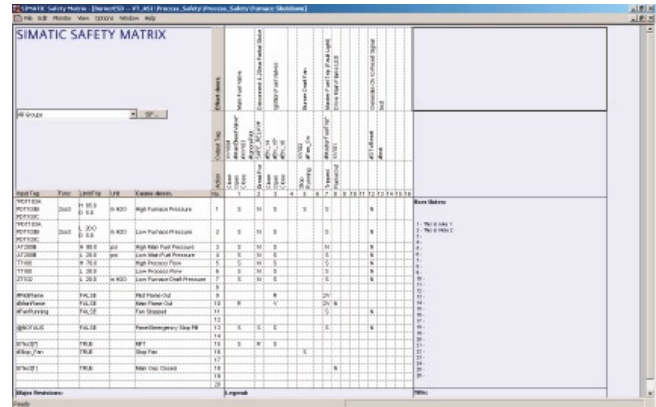

Safety Matrix: assignment of exactly defined reactions (effects) to occurring events (causes)

## SIMATIC Safety Matrix

The SIMATIC Safety Matrix which can be used in addition to S7 F Systems is an innovative safety lifecycle tool from Siemens, that can be used not only for the user-friendly configuration of safety applications, but also for their operation and service. The tool, which is based on the proven principle of a cause & effect matrix, is ideally suited to processes where defined states require specific safety reactions.

The Safety Matrix not only means that programming of the safety logic is significantly simpler and more convenient, but also much faster than in the conventional manner.

During the risk analysis of a plant, the configuration engineer can assign exactly defined reactions (effects) to events (causes) which may occur during a process. The possible process events (inputs) are initially entered in the horizontal lines of a matrix table comparable to a spreadsheet program and then their type and quantity, logic operations, any delays and interlocks as well as any tolerable faults are configured. The reactions (outputs) to a particular event are then defined in the vertical columns.

The events and reactions are linked by simply clicking the cell at the intersection point of line and column. Using this procedure, the Safety Matrix automatically generates complex, safety-related CFC programs. Special programming knowledge is not required and the configuration engineer can concentrate fully on the safety requirements of his plant.

For additional information, see:

[www.siemens.com/simatic-pcs7/process-safety](http://www.siemens.com/simatic-pcs7/process-safety)



# SIMATIC SIS compact

SIMATIC SIS compact is a complete stand-alone safety system, based on tried-and-tested, selected hardware and software components. It was developed for use in dedicated Safety Instrumented Systems (SIS) for critical process industries. Examples include:

- Burner Management System (BMS)
- Emergency Shutdown System (ESD)
- Fire&Gas (F&G) applications
- High Integrity Pressure Protection Systems (HIPPS)

SIMATIC SIS compact provides functional safety and protects humans, the environment, and the factory from dangerous events by bringing the process to a safe state in the event of a critical process situation.

The SIMATIC SIS compact system uses the well-established safety components SIMATIC S7 F Systems and the SIMATIC Safety Matrix as a standard. This easy-to use system is designed for cost-effective, functional safety solutions for small to mid-size plant configurations.

Starting with one of the predefined bundle sets, you can build a fail-safe application and benefit from the advantages of automation technology with this system.

### SIMATIC SIS compact bundles

SIMATIC SIS compact is available in four different bundle versions:

- SIMATIC SIS compact Basic Package Single
- SIMATIC SIS compact Basic Package Redundancy
- SIMATIC SIS compact Extended Package Single
- SIMATIC SIS compact Extended Package Redundancy

The "Basic Package" versions are tailored to the controller level, including a Modbus connection to other automation systems. The "Extended Package" versions, in contrast, cover the controller and HMI level.

### CPU 410SIS

The basic hardware for SIMATIC SIS compact is CPU 410SIS, which is based on CPU 410. It has 4 MB main memory and no limitation for the cycle times.

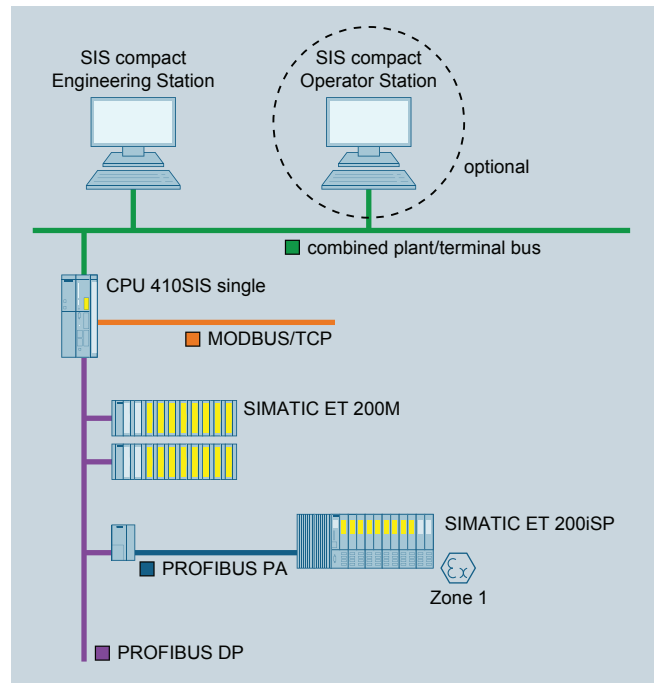

Configuration example with SIMATIC SIS compact Basic Package Single

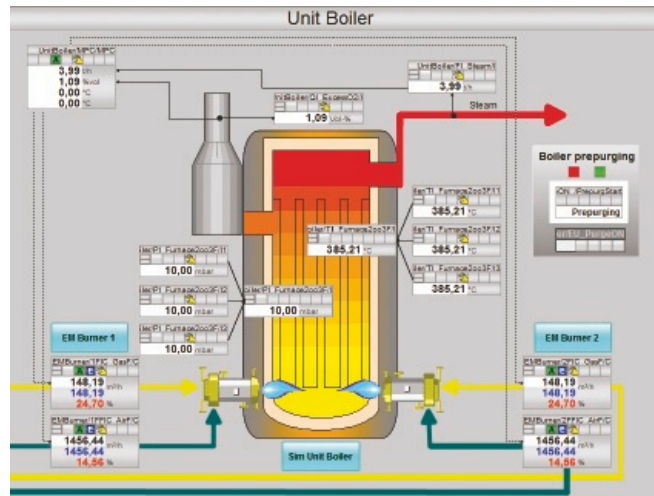

Process screen from a Burner Management System (BMS)

# Industrial Security

## Comprehensive protective measures for I&C plants

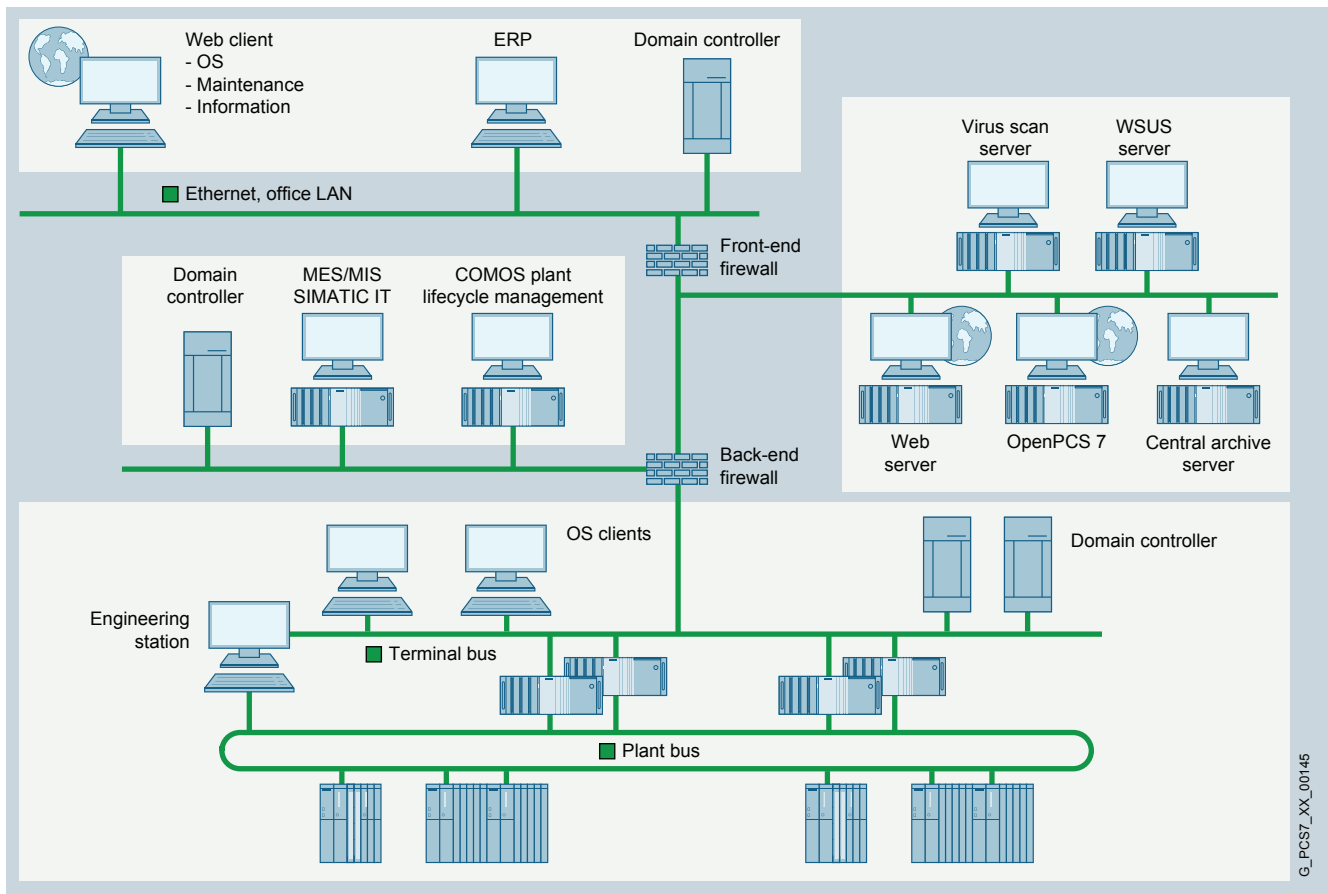

Example of staggered security architecture

Progressive standardization, opening and networking of control systems has been accompanied by an enormous increase in security risks for a process control plant. The potential dangers arising from destructive programs and access by unauthorized personnel range from network overloads or failures, theft of passwords and data, to unauthorized access to process automation. Apart from material damage, specifically targeted sabotage can also have dangerous consequences for personnel and the environment.

### SIMATIC PCS 7 security concept

The SIMATIC PCS 7 security concept, which is described in the manual "Security Concept PCS 7 & WinCC (Basic)" manual and in detail in other documents, provides far-reaching recommendations (best practices) for safeguarding a process plant based on a defense-in-depth security architecture. It is not only restricted to the use of individual security methods (e.g. encryption) or devices (e.g. firewalls).

The strengths of this holistic concept lie rather in the interaction of a host of security measures in the plant network:

- Design of a network architecture with graded security levels (defense in depth), combined with segmenting of the plant into security cells
- Network management, network segmentation
- Operating plants in Windows domains
- Administration of Microsoft Windows and SIMATIC PCS 7 operator privileges; integration of SIMATIC PCS 7 operator privileges into the Windows administration
- Reliable control of time synchronization
- Management of security patches for Microsoft products
- Use of virus scanners and firewalls
- Support and remote access (VPN, IPSec)

## System support for the security concept

On the system side, SIMATIC PCS 7 supports the implementation of guidelines and recommendations of the security concept:

- Compatibility with current versions of the antivirus software, Trend Micro OfficeScan, McAfee VirusScan Enterprise and Symantec Endpoint Protection
- Use of the local Windows firewall
- Automatic setting of security-relevant parameters such as DCOM and Windows firewall already during setup
- User administration and authentication with SIMATIC Logon (one-factor and two-factor authentication)
- CP 1628 Industrial Ethernet interface with integrated security functions (firewall, VPN)
- Integration of SCALANCE S industrial security modules
- Automation firewall
- Application whitelisting with McAfee Application Control

## SCALANCE S industrial security modules

The rugged SCALANCE S602, S612, S623 and S627-2M industrial security modules can be used, for example, to safeguard the cross-cell data exchange between components of automation and process control systems. They possess security functions such as stateful inspection firewall, port filter, NAT and NAPT address conversion and DHCP server. S612, S623 and S627-2M additionally provide authentication and data encryption with Virtual Private Network (VPN) via IPsec tunnel.

## Automation firewall

The automation firewall is provided with stateful inspection packet filters, application layer firewall, VPN gateway functionality, URL filtering, Web proxy, and intrusion prevention. It thus protects the access point to the production environment, e.g. from the office or intranet/Internet networks. It can be used as follows, depending on plant size:

- Three-homed firewall for small to medium-sized plants with minimal perimeter network
- Front and back firewall for maximum protection of larger plants with extensive perimeter network

Integrated services such as hotline support, replacement service and Software Update Service enhance the automation firewall even more.

## Application whitelisting

Application whitelisting protection mechanisms guarantee that only trustworthy applications and programs are executed on a station of the SIMATIC PCS 7 process control system. They prevent the execution of illegal software and the modification of installed applications and thus add to the existing protection against malware (malicious software).

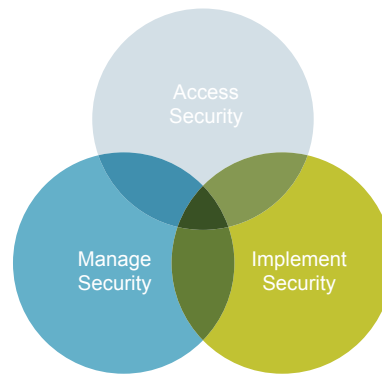

Siemens plant security services

## Plant security services

Siemens not only provides its process control customers with technology, but also supports protection for their systems over the entire lifecycle with integrated Plant Security Services:

- Security assessment
  - Analysis and assessment of the safety level of the plant
  - Identification of vulnerabilities and deviations from standards or norms
  - Recommendation of measures for improving safety
- Security implementation
  - Employee training
  - Improvement of processes with plant-specific implementation of safety-relevant guidelines
  - Implementation of protective measures and long-term monitoring
- Security management
  - Proactive protection of the plant through continuous monitoring during operation
  - Warning of new threats and vulnerabilities in real time
  - Permanent updates for fast protection against new vulnerabilities

## Security certification

Because the security of control systems has high priority for Siemens, the SIMATIC PCS 7 process control system is regularly reviewed by independent experts. TÜV SÜD confirms that the SIMATIC PCS 7 process control system conforms with the security standards IEC 62443-4-1 and IEC 62443-3-3. The process control system offers comprehensive security measures and functions for secure plant operation. With this certificate, the company documents its security approach for automation products, and gives integrators and operators a transparent insight into its industrial security measures.

For additional information, see:  
[www.siemens.com/pcs7/security](http://www.siemens.com/pcs7/security)  
[www.siemens.com/industrial-security](http://www.siemens.com/industrial-security)  
[www.siemens.com/plant-security-services](http://www.siemens.com/plant-security-services)

# Virtualization

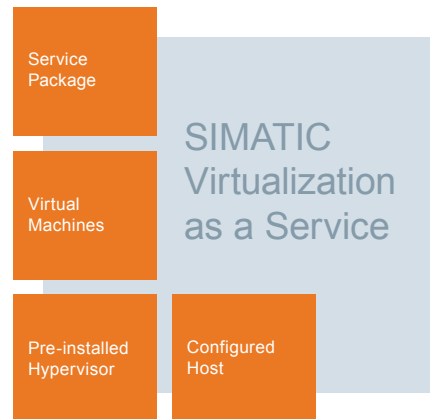
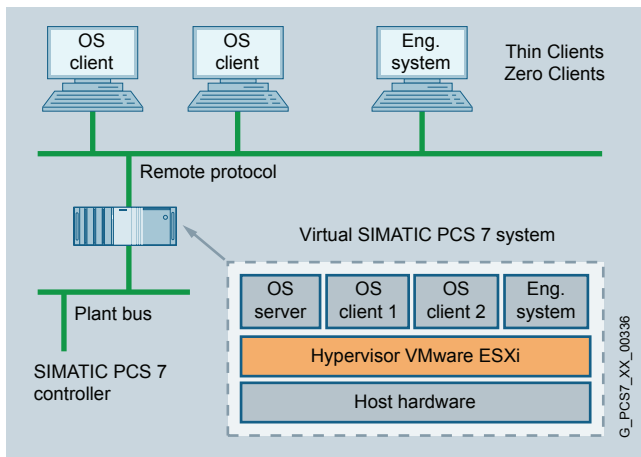

## Virtualization solutions with SIMATIC PCS 7

Virtualization is an innovative software technology for emulation of hardware, operating system, data memory and networks, which is also increasingly finding its way into industrial automation. The initially higher investments for hardware, visualization software, service contracts and infrastructure pay off as a result of long-term savings in operating costs in most cases during the plant's lifecycle.

Profitability essentially depends on the special project requirements which are characterized by aspects such as space requirements, remote access, energy saving, validation, plant layout, infrastructure or by virtual operation of other applications such as evaluation tools and information/reporting systems.

Cyber security is just as important in the virtual world as in the real environment. Therefore, comparable security mechanisms and methods are applied, e.g. security patches, virus scanners, user management or access protection.

Virtualization solutions based on SIMATIC PCS 7 have currently been approved for clients (OS, Batch, Route Control) and Process Historian/Information Server as well as add-ons such as SFC Visualization, OpenPCS 7/OS Client, PCS 7 Web Server or PCS 7 terminal server or WinCC Data Monitor. Servers (OS, Batch, Route Control), engineering system or OS single station or maintenance station can also be operated in the virtual environment specific to the project.

Inexpensive thin clients or zero clients can be used for the operator control and monitoring stations as well as the engineering workplaces. We recommend RDP (Remote Desktop Protocol) for operator stations equipped in this way. The operator control and monitoring functionalities known from the real plant are available to operators on these stations.

## SIMATIC Virtualization as a Service

The creation of virtual systems for customer-specific process control projects based on SIMATIC PCS 7 requires extensive knowledge and experience – of both SIMATIC PCS 7 as well as the employed IT technologies.

With "SIMATIC Virtualization as a Service", Siemens provides hardware (host and thin client), software and lifecycle service for the virtual system – directly from a single source and perfectly coordinated with each other. This offer includes:

- Setup of a complete virtualization host
- Configuration of the virtual machines
- Installation and configuration of the operating systems
- Installation of the SIMATIC/SIMATIC PCS 7 software
- Comprehensive service package

It is expandable with additional hardware and software components as well as additional lifecycle services, including Managed Support Services and SIMATIC Remote Services.

For additional information, see:  
[www.siemens.com/sivaas](http://www.siemens.com/sivaas)



# Package Units and Panel Integration

## SIMATIC PCS 7 Industry Library

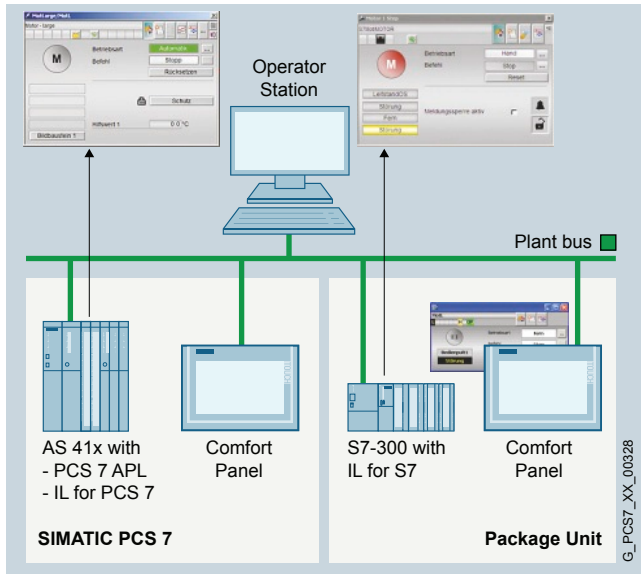

The standard functionality for graphic configuration of automation solutions already defined in the SIMATIC PCS 7 Advanced Process Library (APL) can be expanded by specific technological functions using the SIMATIC PCS 7 Industry Library (IL). In addition to individual blocks, faceplates and symbols which are specifically designed for special I&C tasks in various industrial sectors, the IL also provides sector-specific package units, e.g. for the water/wastewater or building automation sectors. The uniformly styled blocks of IL and APL can be used to create harmonic user interfaces which provide a uniform look and feel.

### Operator control and monitoring per Comfort Panel

Operator control and monitoring of automation functions (APL/IL) on a touch panel is possible using IL interface blocks. Configuration takes place in the CFC by linking to the technological block, e.g. a motor. Taking operating rights and hierarchical operating concepts (multi-control room operation) into consideration, the technological function executed in a SIMATIC PCS 7 automation system or SIMATIC S7-300 controller can then be operated from an operator station and also from a Comfort Panel.

### S7-300 package units

The Industry Library not only supports the engineering of automation systems and operator stations of the SIMATIC PCS 7 process control system, but also the configuration of package units based on SIMATIC S7-300 controllers. The S7-300 package units can be seamlessly integrated into the process control system using IL blocks and homogeneously embedded in the HMI of the SIMATIC PCS 7 operator station. The function blocks are configured in CFC. The following are available for this:

- Panel interface blocks for IL functions
- Analog monitoring of 8 freely selectable limits
- Analog monitoring with additional binary limit monitoring
- Equipment monitoring for up to 8 units
- Analog measured value monitoring
- Digital measured value monitoring
- 3-point actuator (flaps, motors, valves, etc.)
- PID controller
- Operator control blocks
- Valve control
- Motor control (standard motor, with 2 directions of rotation, with variable speed)
- Functions for building automation
- AS-to-AS communication for reading/writing of data

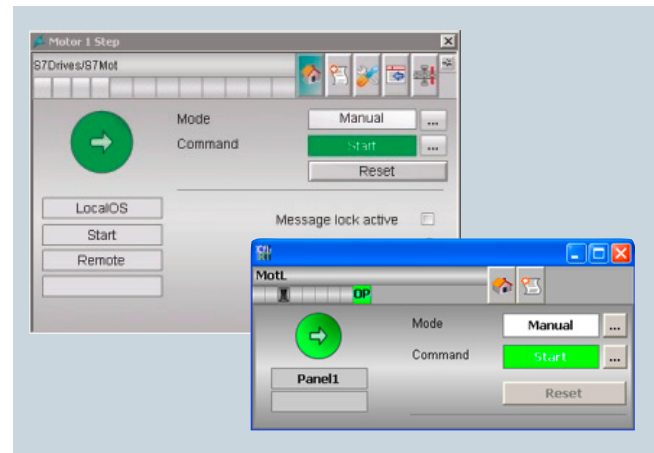

Faceplates of a motor control for operator station (top) and panel (bottom)

# Telecontrol

## Telecontrol with SIMATIC PCS 7 TeleControl

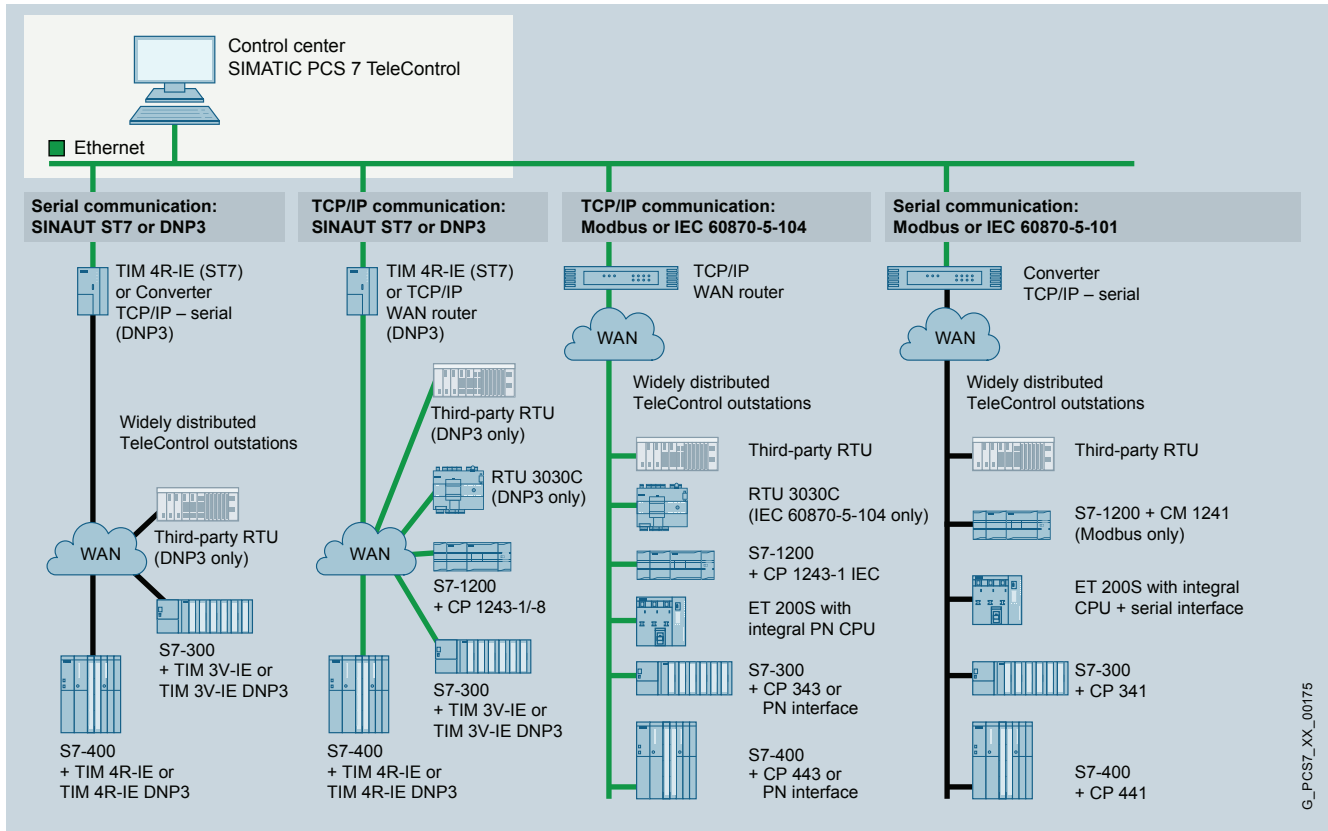

Integration and communication options with SIMATIC PCS 7 TeleControl

Plants often extend over huge areas, especially in the water & wastewater and oil & gas industries. In such cases it is necessary to integrate outstations for monitoring and controlling highly remote units (usually with a small or medium degree of automation) into the control system of the complete plant. This is carried out by means of telecontrol protocols over a WAN (Wide Area Network).

The telecontrol center for the outstations (consisting usually of simpler remote terminal units (RTUs)) can be integrated directly into the process control system using SIMATIC PCS 7 TeleControl.

This results in significant advantages compared to conventional solutions in which central and remote plant areas are configured as separate units and then combined in a higher-level network control system. Benefits include:

- Uniform process control
- Simple and user-friendly data management
- Integrated engineering for central and remote plant units
- Lower service and training costs

The telecontrol center is integrated into the SIMATIC PCS 7 process control in the form of an operator station in single station or server design (also redundant as option). This PCS 7 TeleControl Operator Station is dedicated to telecontrol operation. However, with smaller configurations, it can also control SIMATIC PCS 7 automation systems in central plant areas in parallel with telecontrol systems (dual-channel operation).









There are no differences between central and remote automation with regard to operating philosophy and alarm response. Data from the RTUs of the telecontrol system can be displayed in one process picture together with data from SIMATIC PCS 7 automation systems.

To enable engineering of the TeleControl Operator Station (single station/server), the functions of the central engineering station of the SIMATIC PCS7 process control system are expanded. In addition to technological objects for processing and displaying process data, the provided object library also contains diagnostics objects for communication diagnostics and control.

These blocks support SIMATIC PCS 7 compliant operator control by means of symbols and faceplates, as well as the hierarchy of SIMATIC PCS 7 fault messages. If necessary, the library can be expanded for specific projects with new script-based object types.

For additional information, see:  
[www.siemens.com/simatic-pcs7/telecontrol](http://www.siemens.com/simatic-pcs7/telecontrol)

	RTU type	RTU category	Possible telecontrol protocols
	Compact telecontrol station SIMATIC RTU3030C with autonomous power supply	<b>Very small</b> with up to <b>16 I/Os</b> For very small applications	DNP3, IEC 60870-5-104
	Controller integrated in SIMATIC ET 200S	<b>Small</b> with approx. <b>30 ... 200 I/Os</b> For small applications	Modbus RTU, IEC 60870-5-101/-104
	Controller SIMATIC S7-1200/S7-1200F	<b>Small</b> with approx. <b>30 ... 150 I/Os</b> For small applications	SINAUT ST7, DNP3, Modbus RTU, IEC 60870-5-104
	Controller SIMATIC S7-300/S7-300F	<b>Medium</b> with approx. <b>100 ... 2 000 I/Os</b> For medium sized applications	SINAUT ST7, DNP3, Modbus RTU, IEC 60870-5-101/-104
	Controller SIMATIC S7-400/S7-400F	<b>Large</b> with approx. <b>500 ... 5 000 I/Os</b> For larger applications requiring higher performance	SINAUT ST7, DNP3, Modbus RTU, IEC 60870-5-101/-104
	Controller SIMATIC S7-400H/S7-400FH		DNP3, IEC 60870-5-101/-104

# Switchgear Automation

## Integration of switchgear/controlgear automation in the process industry

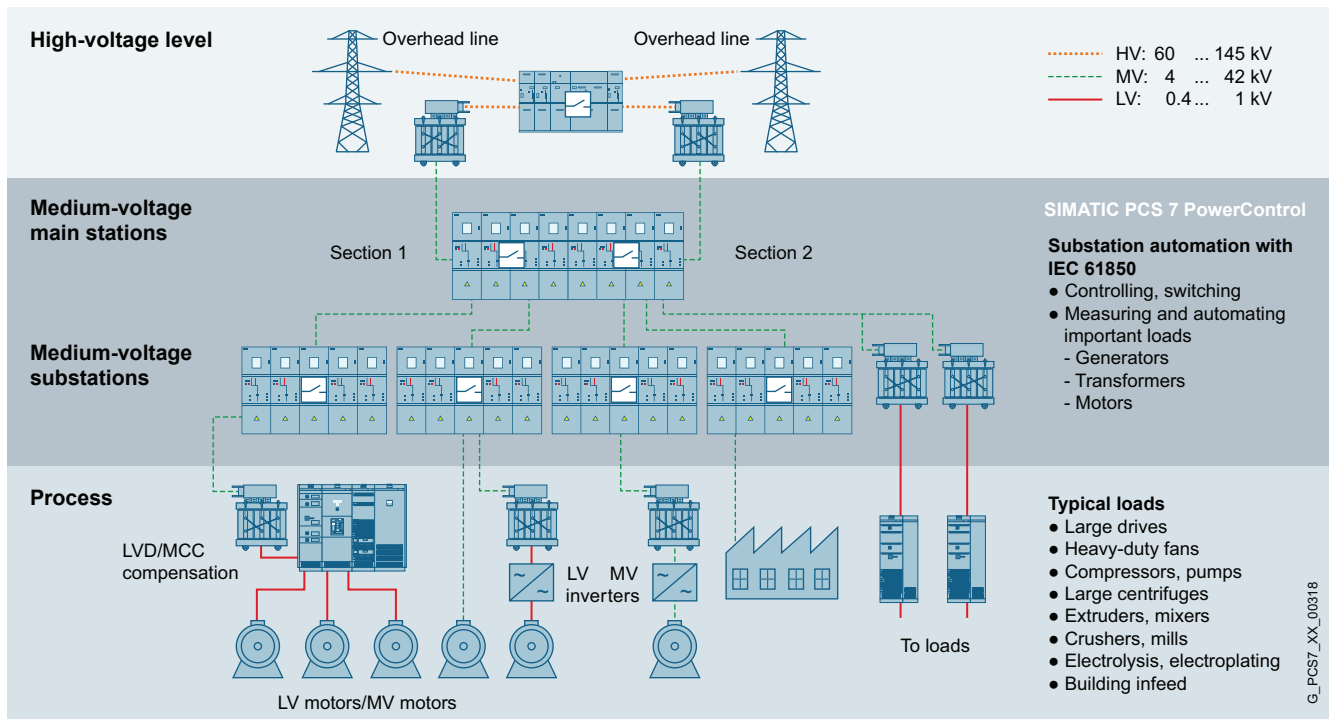

Automation levels in power supply and distribution

An electrical switchgear distributes or transforms electrical energy, bundling loads/consumers into load groups. Using switching devices, network nodes implemented as busbars connect incoming and outgoing cables known as feeders. The switchgear design takes into account the change to the network topology in the event of faults and the isolation and grounding of equipment for maintenance work.

**SIMATIC PCS 7 PowerControl** puts an end to the strict separation between process automation of plants and automation of the power generation for the process. The process automation and automation of electrical switchgear for medium-voltage can be combined in a single control system. This results in numerous advantages with substantial cost savings over the entire lifecycle of the plant, which is gaining in importance with increasing decentralization due to increased use of renewable energy sources, for example:

- Simpler plant structures with more transparency in the technological dependencies
- Further increase in the level of integration of the plant
- Uniform process control supports merging of operator task areas
- Long-term investment security thanks to globally valid standard IEC 61850

- Rational, integrated engineering and fast commissioning
- Lower administration, service and training costs thanks to uniform holistic view
- Cost-effective modernization of plants using an existing PROFIBUS DP infrastructure

### Integration of devices for switchgear automation

Intelligent electronic devices (IEDs) for protection, control, measurement and monitoring in the electric power transmission and distribution are integrated into the SIMATIC PCS 7 process control system as follows:

- Via Ethernet TCP/IP communication with IEC 61850 transmission protocol
  - Direct on the plant bus
  - Via a station controller on the plant bus
  - Via a station gateway (single or redundant) on the plant bus
- With driver blocks of the PCS 7 PowerControl PROFIBUS Driver Library
  - On PROFIBUS DP (SIPROTEC protection devices)



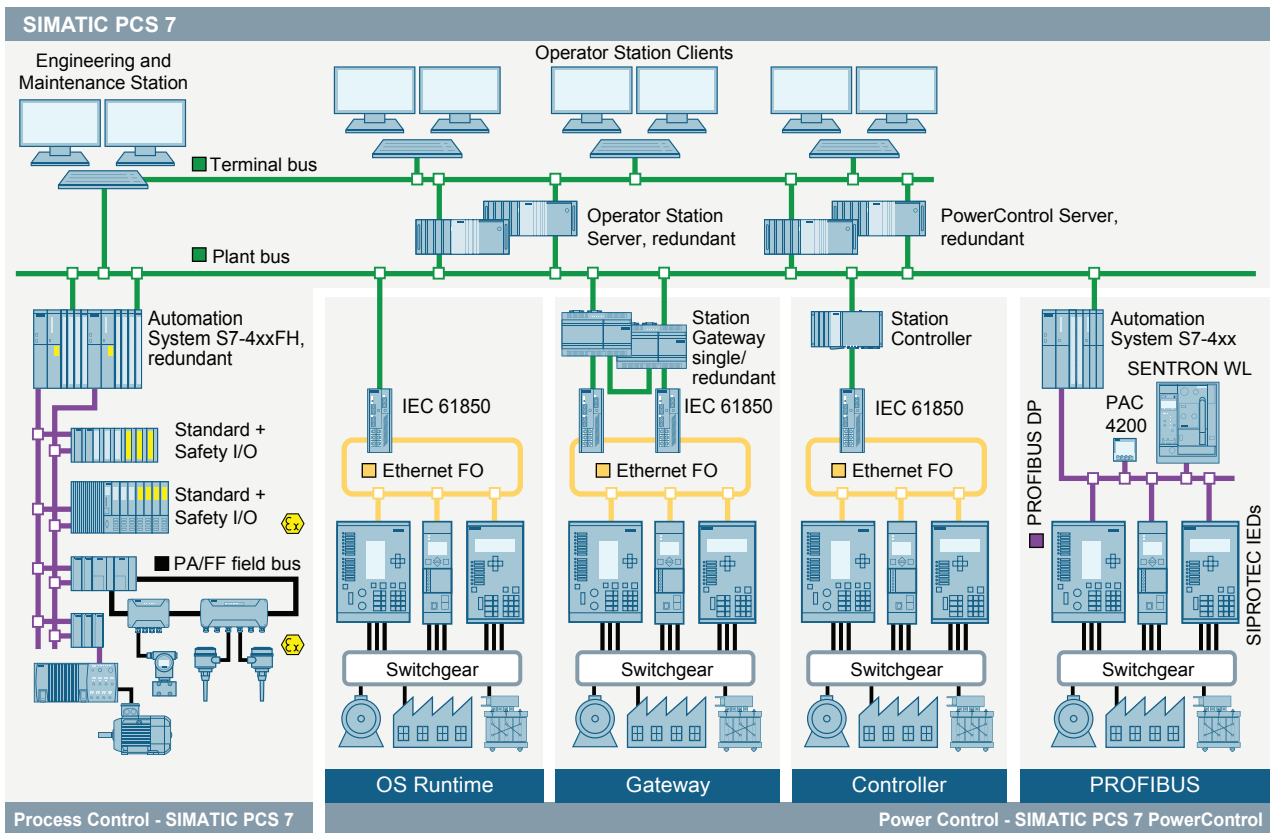

G\_PCS7\_XX\_00356

Integration options for automating medium voltage switchgears



Example of a plant display for medium-voltage switchgear with trend window and faceplate of a medium-voltage motor

The integration of IEDs on the PROFIBUS DP is primarily intended for:

- Re-use of existing PROFIBUS DP infrastructures
- Partial modernization of existing plants
- Hybrid configurations of IEC 61850 and PROFIBUS DP in plant expansions

For additional information, see:  
[www.siemens.com/simatic-pcs7/powercontrol](http://www.siemens.com/simatic-pcs7/powercontrol)

## SIMATIC PCS 7 PowerControl at a glance

### SIMATIC PCS 7 engineering

- Object library with function blocks, symbols and faceplates
- Object-oriented type-instance concept
- Automatic generation of the objects for the operator station
- Integration of new IEDs by importing their IEC 61850 Device Description (ICD)
- Additives library with technological blocks for electrical equipment such as feeders, machines, transformers, cables, busbars
- Use of the IED time stamp even for associated values from other sources

### SIMATIC PCS 7 process control

- Faceplates for SIPROTEC protective devices in the SIMATIC PCS 7 APL style (look&feel)
- Standardized behavior in the case of alarms, messages and operator control and monitoring
- Diagnostics functionality for every IED
- Reading and storing IED fault records; analysis with external tools

# Energy Management with SIMATIC PCS 7

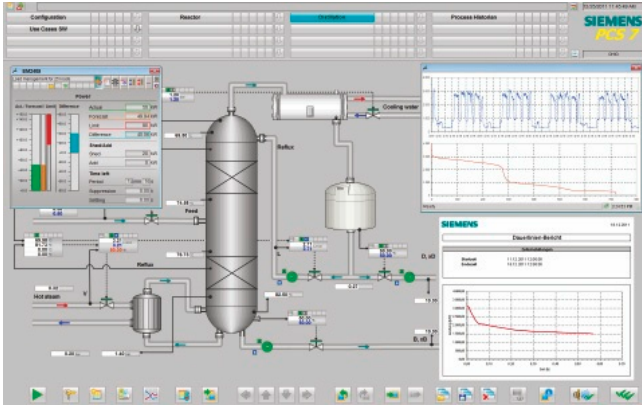

Resources which are becoming scarcer, increasing energy prices, an increased sensitivity for environmental matters and tighter statutory constraints significantly emphasize the importance of efficient energy management. All aspects concerning the generation, procurement, distribution and consumption of energy must be considered.

Companies operating in the process industry must be able to plan, monitor and record their energy consumptions, to define and implement possible energy saving measures and to prove the efficiency through regular evaluation of indicators.

## Identification and evaluation of energy data

Transparency is a basic prerequisite for improving the energy balance, i.e. the measurement and recording of consumption data and the presentation of the flows of energy and media within the company. It is only possible to define potential savings and the required efforts when the consumption of each type of energy is known.

This is supported in the context of the SIMATIC PCS 7 process control system by:

- Basic power monitoring with SIMATIC PCS 7 standard functionality:
  - Data of process-related energies measured using process instruments, such as steam, cooling media or gas
  - Data provided directly by electric components such as circuit-breakers (SENTRON), frequency converters (SINAMICS), motor starters (ET 200SP) etc.
  - Data of other energy consumers measured using power monitoring devices of the SENTRON PAC range
- Load management functions in the Industry Library
  - Monitoring of production and energy consumption forecast
  - Proactive switching of the load according to pre-defined strategy
  - Definition of variable, daytime-dependent load profiles
  - Consideration of the customer's own power generation capacities

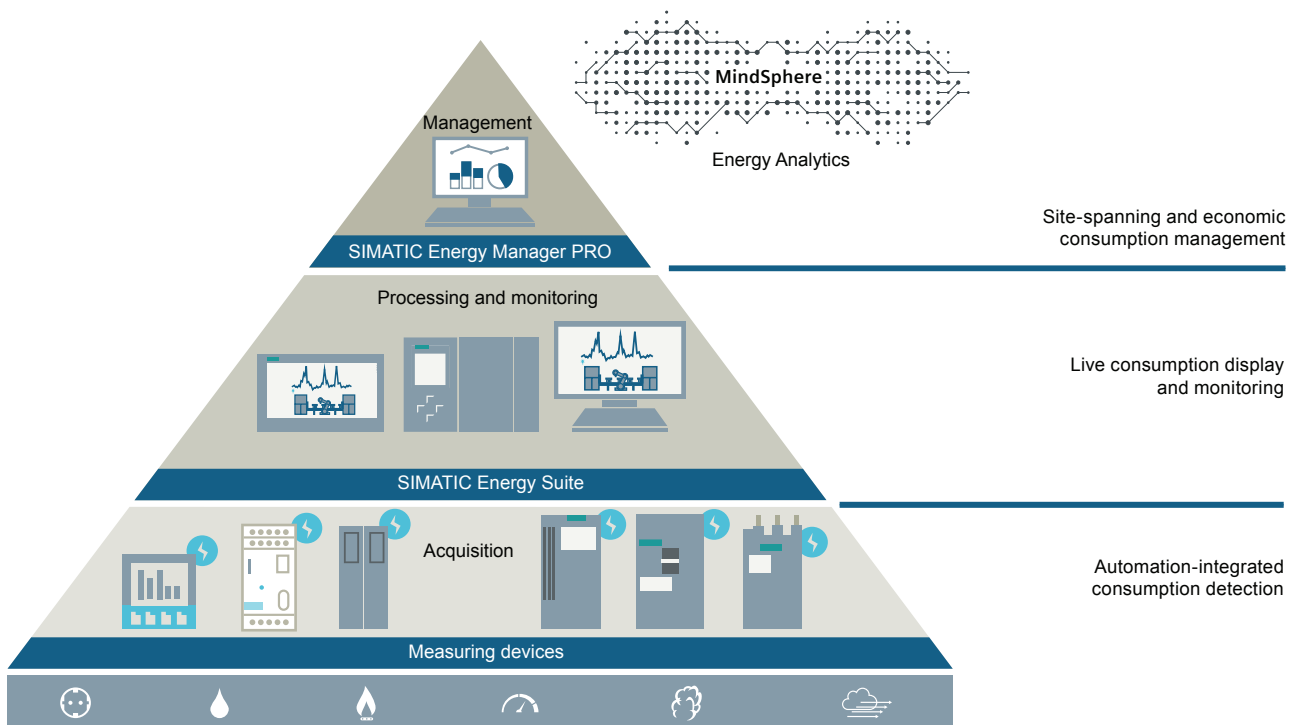

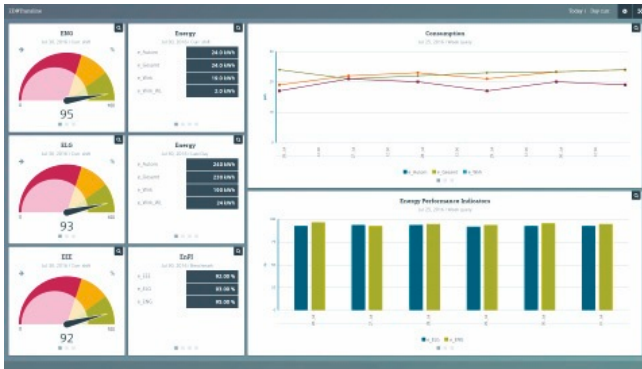

SIMATIC Energy Manager PRO

- SIMATIC Energy Manager PRO for optimization of operational energy management
  - Company-wide transparency thanks to gap-free energy and material balancing of power generation and consumption equipment
  - Usage-based allocation of energy costs and transfer to the accounting system, e.g. SAP R/3 CO
  - Key performance indicators for reliable statements on raising the efficiency of power generation plants and consumers
  - Production-based prediction of loads and requirements to improve planning security
  - Support of cost-effective purchasing of energy
  - Monitoring and reporting of greenhouse gas emissions (CO<sub>2</sub>) in accordance with legal requirements
  - Integrated project management to continuously improve the energy efficiency

### Optimization of energy utilization

SIMATIC PCS 7 can be used to optimize the energy utilization such that previously unused resources can be accessed and consumption peaks avoided. SIMATIC PCS 7 blocks use the current consumption to calculate a prediction for the running 15-minute average and compare this with defined limits. Consumers can be specifically switched off or on, for example, in order to smoothen larger peaks or to observe limits agreed by contract with the energy supplier. In the case of unstable power supplies, loads can also be rapidly disconnected in order to guarantee the operation of critical plant components using the remaining infeed capacity.

Furthermore, the optimization of processes using Advanced Process Control (APC) as well as plant-level asset management with the PCS 7 Maintenance Station provide a significant contribution to energy-efficient plant operation.

For additional information, see:  
[www.siemens.com/simatic-pcs7/energy-management](http://www.siemens.com/simatic-pcs7/energy-management)

### Energy saving with innovative technology

The application of low-energy motors or frequency converters is a further large potential for savings, especially with energy-intensive production processes, e.g. in the chemical or pharmaceutical industry.

#### Energy-saving motors

Energy-efficient motors have a power loss reduced by up to 42%. Since the share of energy costs in the total costs of a motor over its complete lifecycle is approximately 98%, enormous cost savings are attainable for new plants or through modernization of existing plants.

#### Frequency converters with braking energy recovery

Frequency converters make it possible for the equipment in plants, such as pumps, fans or compressors, to always operate within the optimum working range. Energy savings of up to 50% can then be achieved compared to conventional control procedures.

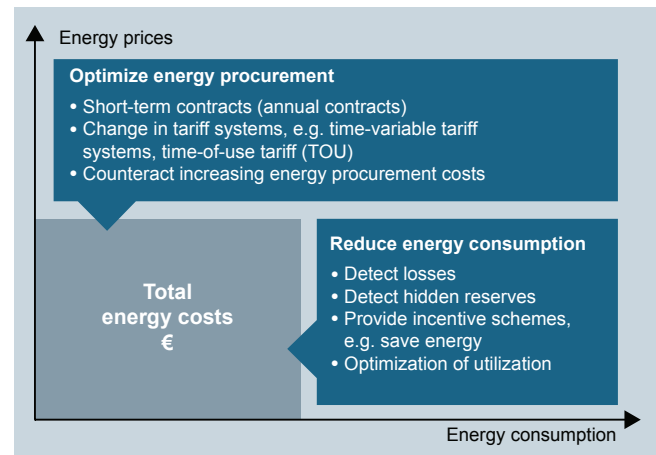

Reduced energy costs

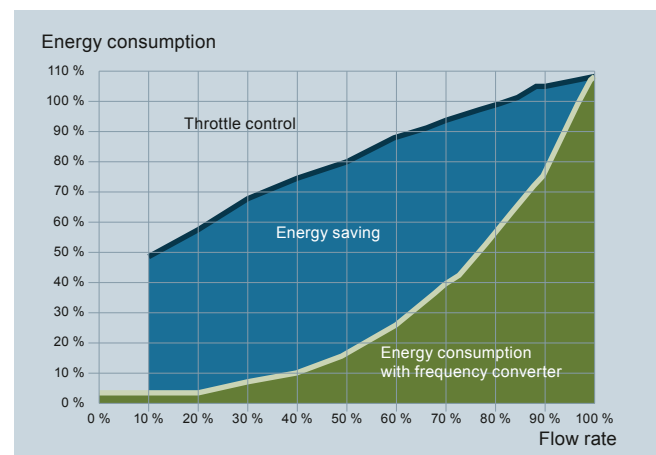

Energy saving potential through frequency converters

# Optimization with Advanced Process Control

With complex processes, control concepts based on PID controllers often reach their limits quickly. Advanced Process Control (APC) functions are integrated in the SIMATIC PCS 7 process control system and provide significantly more options. The application of these advanced control functions permits the following:

- Drastic reduction of undesirable variations in critical process variables
- Noticeable reduction in use of raw materials and consumption of energy
- Increase in throughput and product quality
- Reduction in demands placed on operating personnel

## Integrated advanced process control functions

In addition to numerous basic control functions, e.g. PID control, cascade control, split range control and ratio control, the I&C libraries of SIMATIC PCS 7 provide function blocks and templates at no extra cost for the advanced control functions described below.

Using these model solutions already included in the standard, complex APC applications can be implemented simply and cost-effectively for small and medium-sized plants.

### Override control

With override control, the outputs of two or more controllers are connected to a common final controlling element. The decision concerning which controller actually has access to the final controlling element is made depending on the evaluation of the current process state.

- Two or more controllers share a final controlling element
- Decision for the active controller based on:
  - Measurable output variables, e.g. one of the controlled variables
  - Manipulated variables of the controllers

### Gain scheduling

Gain scheduling enables infinite adjustment of the controller settings in non-linear processes depending on three operating points. Linear interpolation effects soft, bumpless transitions between the operating points so that the parameters can be infinitely modified dependent on the course of the measured variable X.

- Suitable for non-linear processes
- Three complete parameter sets for three operating points

### Dynamic feedforward control

Feed-forward control can compensate a strong, measurable interference in advance so that the control is limited to model uncertainties and non-measurable interferences.

- Compensation of strong, measurable interferences
- Eliminating faults before the appearance of negative effects



### Monitoring of the control performance

The ConPerMon block determines the control quality of the PID controller block. Depending on the deviation from the comparison value, e.g. the control quality during commissioning, it triggers warnings or alarms which can be combined clearly in OS displays for a plant or unit. In this way, problems can be detected, analyzed and specifically corrected at an early stage.

- Online monitoring of the control performance
- Identification of control loops according to the criteria:
  - Maximum urgency for optimization
  - Imminent fault
- Configurable alarm limits for standard deviation
- Graphic evaluation

### Extended Kalman Filter

The Extended Kalman Filter (EKF) is a state monitor (soft sensor) for evaluation of the process quality. The easy-to-use Kalman Configurator provides optimal support when developing the process model. The model is simulated in parallel with the process and constantly synchronized with measurement data. All internal state variables of the model can be read off during runtime and used as a substitute for real measured variables. States can be corrected through sporadic lab samples during operation.

The separation of application-specific knowledge (process knowledge) and EKF algorithms enables significant reduction of the engineering effort.



### PID controller optimization

A model of the process is initially generated using the PID Tuner integrated in the engineering system. Based on this, the most favorable controller settings can be determined, while differentiating between the optimum response to disturbance variable changes or setpoint changes.

- Optimization of PID control loops
- Can be used for standard PID controllers and blocks from user-specific libraries
- Simulation of closed control loops

### Smith predictor

The Smith predictor can significantly improve the control quality of processes with long and relatively constant dead times. The dead time component is eliminated using a process model running parallel to the actual process. The controller can then be designed for a process free of dead time and set more effectively.

- Can be used on processes with long, known and relatively constant dead times:
  - Process model runs parallel to the actual process
  - Feedback of virtual controlled variable free of dead time
  - Feedback of deviation between the measured actual value and the virtual value with dead time
- PI(D) controller design
  - Based on component of process model that is free of dead time
  - Allows significantly more precise controller setting

### Model-based predictive multi-variable control

Model-based predictive multi-variable controllers (MPC) separately analyze the behavior of several interdependent variables for complex processes over a longer period.

The results are used for optimized control of these variables. They eliminate adverse interactions which occur with separate control of the interdependent variables. The integral static operating point optimization can calculate the economically optimal operating point in a tolerance range specified as a setpoint.

Using a mathematical model of the process dynamics, MPCs are able to predict the future process response over a defined period of time (prediction horizon) and optimize a quality criterion on this basis.

Scalable MPC applications:

- Internal ("lean") MPC4x4 (ModPreCon): up to 4 coupled manipulated variables and controlled variables
- Internal MPC10x10: up to 10 coupled manipulated variables and controlled variables, up to 4 measurable disturbance variables
- External "full-blown" MPC (add-on product INCA MPC)

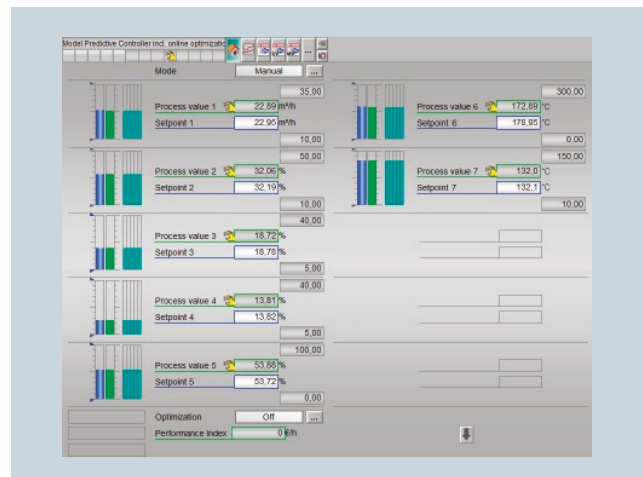

Faceplate for predictive multi-variable controller MPC10x10

The high-performance, internal MPC10x10 is closer in range of features to the PC-based "full-blown" multi-variable controller, but in terms of availability, user-friendliness and costs it offers the immanent advantage of system-integrated controller functions.

Designed for slow and complex control tasks with controller sampling times of  $> 4$  s, it is typically used as a system-spanning master controller in cascade structures. With the Tennessee Eastman benchmark using 5 controlled variables, 6 manipulated variables and 3 measurable disturbance variables, it succeeds as master controller along with nearly 20 PID controllers in providing the following results:

- Compliance with the conditions for reactor pressure, temperature and all fill levels
- Minimization of variability in product quality and production rate
- Minimization of valve movements
- Compensation for interferences
- Change in production rate or product mix with a runtime reaction
- Changing the reaction conditions or the exhaust gas concentration with a runtime reaction

### **Advanced Process Control with SIMATIC PCS 7 add-ons**

Add-ons which can be seamlessly integrated into the process control system expand the range of advanced control functions for SIMATIC PCS 7, e.g. INCA Sensor, INCA MPC or ADCO.

For additional information, see:  
[www.siemens.com/simatic-pcs7/apc](http://www.siemens.com/simatic-pcs7/apc)

# Simulation and Training Systems

## Simulation and virtual commissioning with SIMIT

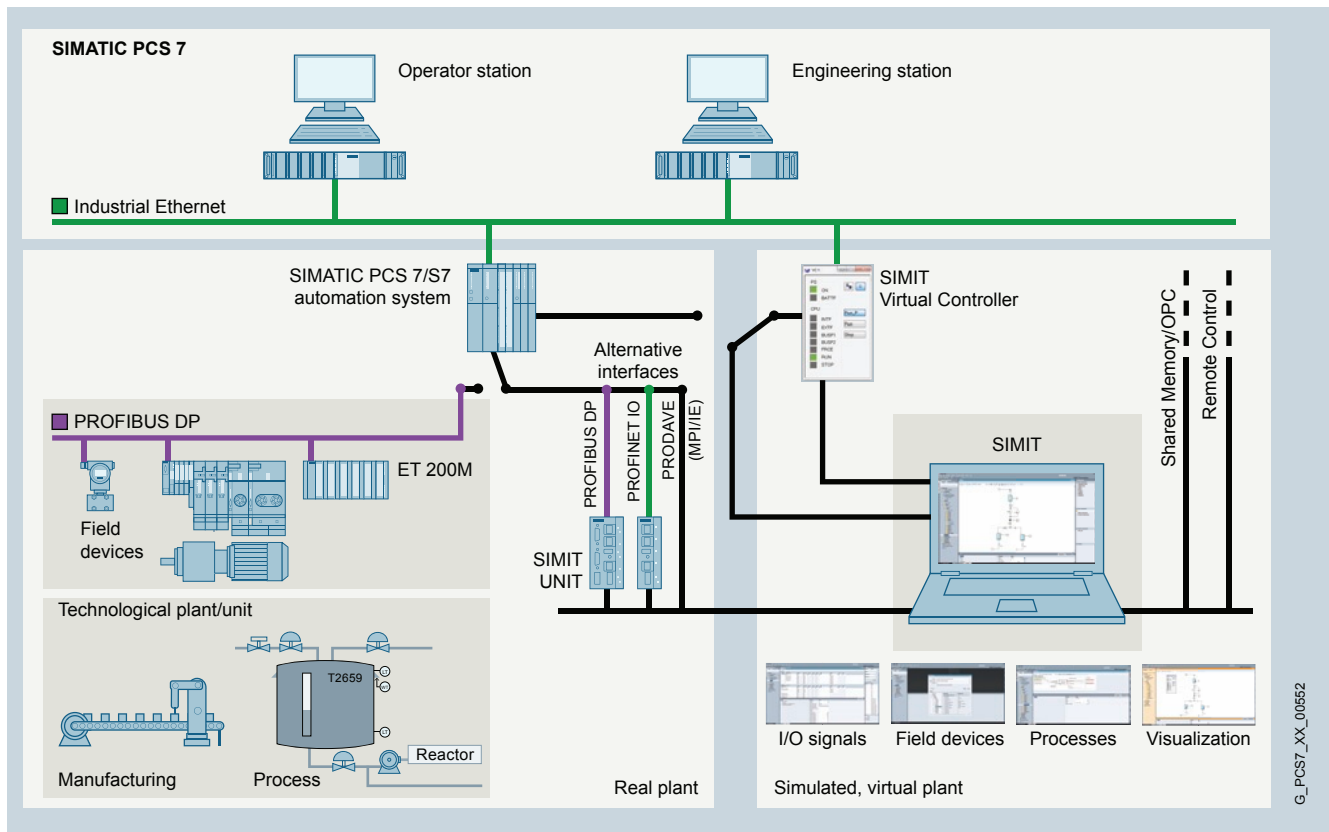

Application and integration options of SIMIT Simulation Framework and SIMIT Virtual Controller

Bringing products to the market faster and with consistently high quality requires an optimized engineering workflow in the automation and the shortest possible assembly and commissioning times for new production lines. The SIMIT simulation software enables real-time simulation and emulation for comprehensive checking of automation solutions.



SIMIT is based on a uniform simulation platform that enables not only the virtual commissioning of the automation technology of systems, machines and processes, but also realistic training environments for plant operators. This can be done quite easily directly at the workstation, even without requiring equipment or the need for in-depth knowledge of simulation. Either a real or virtual automation system is used for the control, for example, the SIMIT Virtual Controller.

Many efficient tests for detection and elimination of potential faults can already be carried out before the real plant is even available, e.g. application of correct identifications, testing of interconnection or interlocking logic. In this way, it is possible to optimize the quality of the configuration process without putting the real plant at risk.

SIMIT can also be used to train personnel to handle the real SIMATIC PCS 7 automation system. In this case, the plant response is simulated for testing and commissioning.

Experienced specialists in the plant simulation sector provide comprehensive consulting, training and support for customized plant modeling.

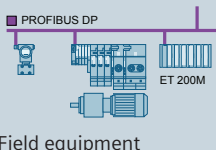
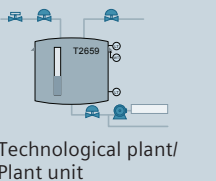
SIMIT can run on current computers and virtual systems (VMware). It can be flexibly used and can be integrated in production automation with SIMATIC S7 and SIMATIC WinCC or in process automation with SIMATIC PCS 7 via open interfaces.

Real plant	Simulation with SIMIT	
 <p>Field equipment</p>	<p>Signals</p> <p>Devices</p>	<p>Import (e.g. symbol table)</p> <p>Basic library for:</p> <ul style="list-style-type: none"> <li>DRIVES</li> <li>SENSORS</li> </ul>
 <p>Technological plant/ Plant unit</p>	<p>Technological characteristics</p>	<p>Additive libraries</p> <ul style="list-style-type: none"> <li>FLOWNET</li> <li>CHEM BASIC</li> </ul>
 <p>Production technology</p>		<ul style="list-style-type: none"> <li>CONTEC</li> </ul>

Abstraction levels of the simulation

Efficient simulation is based on the abstraction on three different levels: signals, devices (e.g. actuators and sensors) and technological characteristics. In this case, the technological characteristics are mapped mathematically and logically or through additional libraries.

Since the models can be calculated in real-time, SIMIT can be linked to the real automation technology ("Hardware in the loop"). The SIMIT unit is used for the interfacing via PROFIBUS or PROFINET A "Software in the loop" test is also possible through virtualization of the automation system using the S7-PLCSIM, S7-PLCSIM Advanced emulation software or the integrated SIMIT Virtual Controller.

Interfacing to the real automation system is usually made via PROFIBUS DP or PROFINET IO. Interfaces (SIMIT units) simulate the devices on PROFIBUS DP/PROFINET IO in this case. A PRODAVE coupling can also be used for the MPI/DP or IE interface of the automation system for process data traffic with SIMIT.

SIMIT supports the joint operation with other simulation models through:

- Data exchange via standardized interfaces such as OPC DA, OPC UA (client) and shared memory
- Synchronization via the remote control interface (with SIMIT in the role as master or client) Using virtual time management, simulations can also be implemented faster or slower than in real-time.

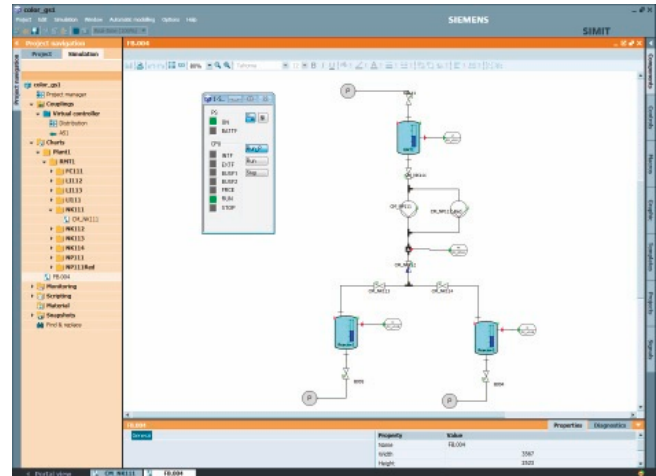

SIMIT, Graphical User Interface (GUI)

Component-based, signal flow oriented modeling of the plant with expandable base libraries via the graphical user interface of SIMIT. The project flow is controlled by an integrated workflow management. Special simulation skills are not required.

Additive libraries support simulation of the technological characteristics.

- FLOWNET for simulation of dynamic curves of pressures, flows and temperature distribution of water in pipeline networks
- CONTEC for simulation of material handling equipment.
- CHEM BASIC for simulation of models of pipeline networks in the chemical and pharmaceutical industries

### Arguments for SIMIT

- Testing of original automation project
- High quality thanks to early detection and elimination of configuration errors
- Virtual commissioning shortens project commissioning times and reduces project costs
- No simulation-specific programming required in the automation project

For additional information, see:  
[www.siemens.com/simit](http://www.siemens.com/simit)

# Interfacing to IT systems

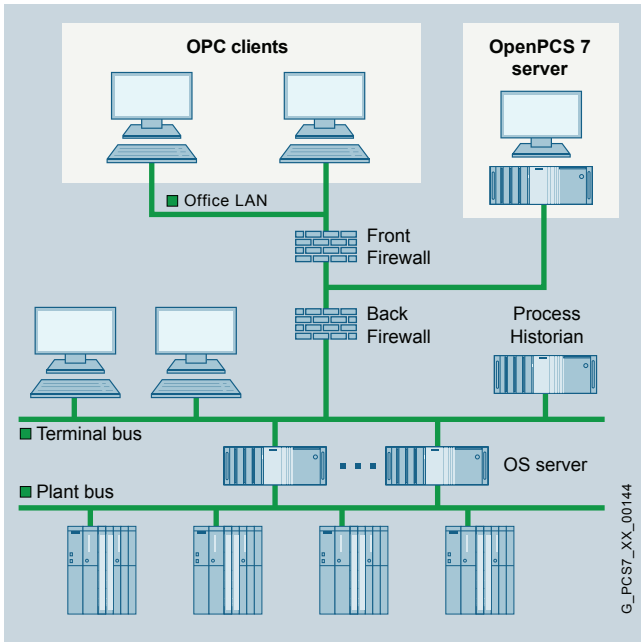

OpenPCS 7 server for data exchange via OPC

## Evaluating and managing process data with OpenPCS 7

Systems for process data evaluation and management (OPC clients) that are at a higher level than the process control system can access SIMATIC PCS 7 process data by means of an OpenPCS 7 server. This server collects data distributed across different SIMATIC PCS 7 stations (OS server, Process Historian) depending on the system configuration. OpenPCS 7 utilizes both the DCOM technology and the advanced OPC Specification OPC UA (Unified Architecture).

Access to station	OPC interface	Data type/ Access type
OS Server	DA or UA DA (Data Access)	Read/write access to process values
	A&E (Alarm & Events)	Read and acknowledging access to alarms and messages
OS Server/ Process Historian	HDA (Historical Data Access)	Read access to archived process values
	H A&E (Historical Alarms & Events)	Read access to archived alarms and messages

Simple, standardized direct access to the archive data in the Microsoft SQL server database of the operator system is possible with the OLE-DB. Through this, all OS archive data are accessible with the accompanying process values, message texts and user texts.



## Integration and synchronization of all business processes with SIMATIC IT

The competitiveness of a company depends on a quick response to market requirements and optimization of the supply chain. At the interface between production and management, Manufacturing Execution Systems (MES) ensure uniform optimization of corporate processes and therefore greater efficiency, integrated transparency and consistent quality.

With SIMATIC IT, Siemens has one of the most powerful and flexible MES systems on the market. SIMATIC IT works homogeneously with all major ERP and process control systems. Modeling of the entire product manufacturing know-how, precise definition of the operating processes and real-time data acquisition from the ERP and the production level enable SIMATIC IT to control operating processes more effectively, to minimize downtimes, production waste and follow-up work and to optimize stockholding.

You can find detailed information about SIMATIC IT suites, components and libraries in the Internet: [www.siemens.com/mes](http://www.siemens.com/mes)



# Controller Integration with PCS 7/OPEN OS

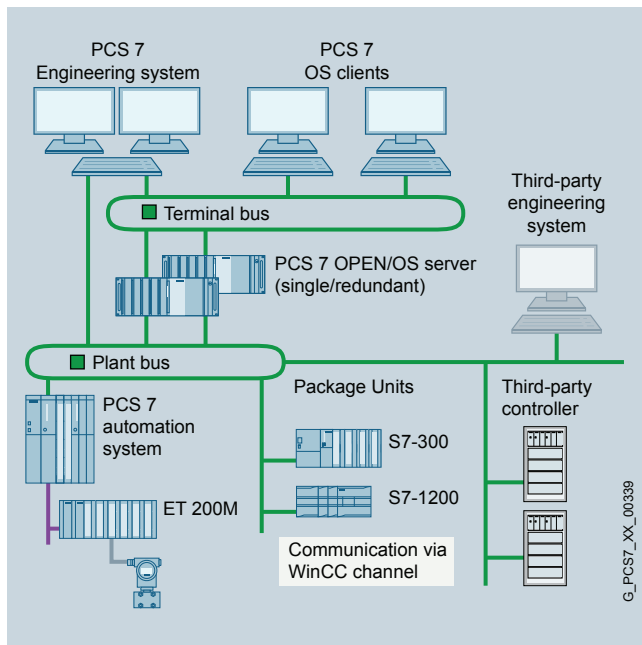

Example for the integration of third-party controllers and package units in PCS 7/OPEN OS

As a result of developments over many years, I&C plants frequently have heterogeneous structures in which system components from different manufacturers are combined. During plant modernizations, owners endeavor to increase the efficiency of process control by simplifying the HMI level. In the case of plant expansions where control desks are merged or existing plants are migrated step-by-step, the challenge is to integrate different types of controller in one HMI system.

The SIMATIC PCS 7 operator system can be expanded by PCS 7/OPEN OS for such purposes. It can be used to integrate the following controllers into the process management:

- Third-party controllers of control systems
- Programmable logic controllers from Siemens and other manufacturers
- Package units

Depending on the technical situation of the controller to be integrated, connection to the PCS 7/OPEN OS operator station is possible via OPC (OPC DA and OPC A&E) or the existing WinCC channels (e.g. S7 channel or Modbus TCP channel). In the case of OPC communication, the OPC server can be executed on separate hardware or together with the OPC client on the PCS 7/OPEN OS operator station.

The existing engineering system of the controller can be used further to configure the automation functions.

The basis for OS engineering with the PCS 7 engineering system is the Toolset Database Automation (DBA) of PCS 7/OPEN OS. It is then possible to rapidly and simply create OS objects in SIMATIC PCS 7 design for the controller to be integrated. Manual inputs are limited to organization of the project, the creation of static display elements, archive definition, user management and customized adaptations.

## DBA functions

- Generating the display hierarchy
- Automatic creation of displays with icons and faceplates in the hierarchy tree
- Automatic creation of the variables function in the operator station
- Automatic creation of messages
- Assignment of message priorities
- Definition of the process variables to be archived
- Creation of trends
- Export/import for mass data processing
- Type editor for creation of function block images of the existing controller
  - Creation of data structures (structure types)
  - Import/export and documentation of types
  - Creation of type from instance
  - Integration of type into another type

## Further relevant PCS 7/OPEN OS functions

- PH synchronization: alignment of plant hierarchy with existing PCS 7 project
- Multi-project engineering: division into several DBA projects, e.g. system-granular
- Online scripting: creation of scripts for supplementary functions, for execution during runtime

## Handling package units

Package units can be created once in PCS 7/OPEN OS and supplied as an OS typical on CD or per download. On site, the configuration engineer imports this typical and generates instances from it according to the number of units. The package units can subsequently be visualized in the SIMATIC PCS 7 process displays.

# Migration of Our Systems

## An investment for the future

Globalization and the intensified competition that accompanies it are forcing companies to shorten the time needed for product launches and to continuously increase productivity. In order to remain competitive, existing systems and plants have to be repeatedly expanded and modernized. In all modernization strategies, however, the value of the installed base must be taken into account in terms of hardware, application software and expertise of the operating and maintenance personnel.

In view of the complexity of many migration projects, decisive prerequisites for migration success include the analysis and design of the correct procedure, including a realistic assessment of the opportunities and risks. The migration experts at Siemens have already acquired relevant experience in migrating the most diverse systems. In close partnership with the customer and his system integrators, they develop individually tailored, future-proof solutions based on the state-of-the-art SIMATIC PCS 7 process control system.

With very old systems, complete replacement by the new process control system is usually the preferred method. By integrating components worth keeping such as controllers or I/O modules, sometimes significant investment savings can be achieved and conversion times shortened.



Siemens provides dedicated SIMATIC PCS 7 migration products and solutions for both for its own legacy systems as well as systems from other manufacturers (e.g. ABB, Honeywell, Emerson or Invensys). The universal OPC-coupled SIMATIC PCS 7/Open OS is increasingly being used here. To complete the portfolio, there are products for communication between old and new systems or for fast switchover of field wiring in migration projects, e.g. specific gateways, connectors, cables and field termination assemblies (FTA).

Even if the hardware is largely obsolete, the available controller engineering can still represent significant value. The entire process automation know-how, often optimized over a period of years, is concentrated here. Intelligent tools help to analyze this data and in certain circumstances, they can significantly reduce costs for re-engineering the new system thanks to functional implementation (typicals).

For additional information, see:  
[www.siemens.com/simatic-pcs7/migration](http://www.siemens.com/simatic-pcs7/migration)

# Services

## Industry Services

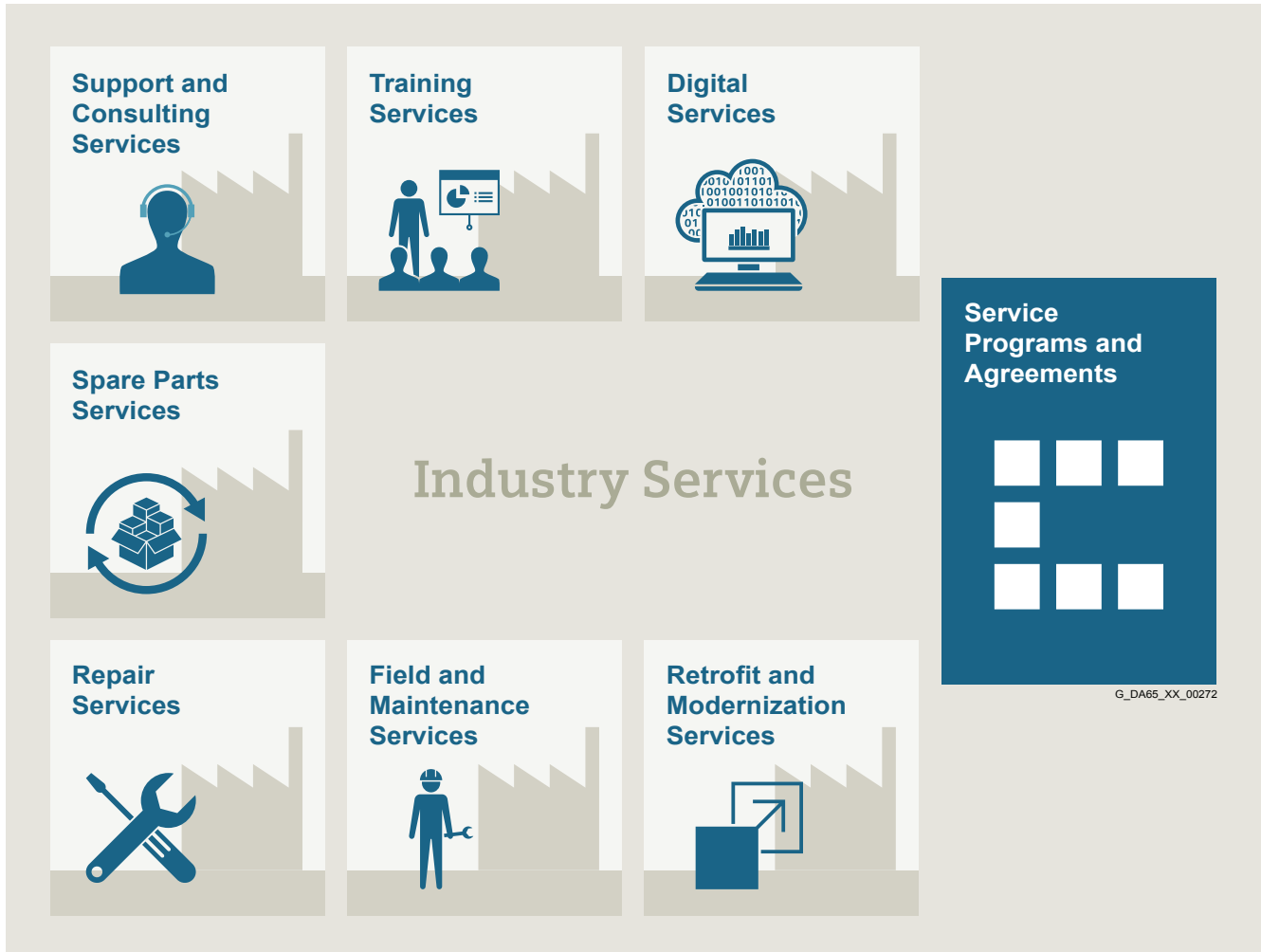

Process control customers are confronted with the challenge to optimize operations, productivity and total cost of their plants and to react to changing market conditions. In this context, it is important for them to minimize downtime, optimize the use of resources and energy, develop new optimization potential through data analysis and protect against cyber threats.

The service experts from Siemens support them throughout the entire lifecycle of the system with a comprehensive range of services, the Industry Services. The dedicated team of engineers, technicians and specialists have in-depth knowledge about products, systems and technologies and understand the specific requirements of the industries.

### Support and consulting services

Industry Online Support is round-the-clock service on the Internet that provides extensive product information and software downloads. Customers can also ask support questions or share information with other users.

The specialists at Technical and Engineering Support provide 24/7 consultation and answer any questions concerning functionality, operation and troubleshooting.

Information & Consulting Services are designed to analyze the condition and serviceability of systems and to gain insights into the service life of the products used.



### **Training services**

SITRAIN courses are available directly from the manufacturer at over 170 locations in more than 60 countries worldwide. They impart both basic knowledge and advanced technical skills. The course program covers the full range of Siemens products and systems for the industry. The practical SIMATIC PCS 7 courses enable the participants to effectively use the process control system even after a short time.

### **Digital services**

In order to make the process transparent and reach more informed decisions, production data are recorded, filtered and analyzed with intelligent analytics. Data security and continuous protection against cyber attacks have a high priority.

### **Spare parts services**

The Spare Parts Service from Siemens organizes smooth and fast worldwide delivery of original spare parts made available up to 10 years. Logistics experts manage procurement, transportation, customs clearance, storage and order processing, and ensure that the spare part components reach their destination as quickly as needed. Plant Optimization Services assist customers in the development of a spare parts supply strategy, which makes it possible to reduce capital and transportation costs and avoid the risks of obsolescence.

### **Repair services**

Repair Services are available at local and regional repair centers to put faulty products back into operation as fast as possible. Additional diagnostic and repair actions as well as emergency services enhance this offer.

### **Field and maintenance services**

Siemens specialists offer worldwide professional maintenance services, including commissioning, functional testing, preventive maintenance and troubleshooting. All services can also be components of individually agreed service contracts.

### **Retrofit and modernization services**

This offer includes cost-effective solutions for expanding entire plants, optimization of systems or modernization of existing products to include the latest technology and software, for example, migration services for automation systems. Service experts support projects from planning to commissioning and, on request, over the entire service life.

Discover all the advantages of our service portfolio:  
[www.siemens.com/industry-services](http://www.siemens.com/industry-services)



# SIMATIC PCS 7 Lifecycle Services

As well as global service and support, the range of services also includes special services for the process industry that can be used independently of each other and flexibly adapted and combined.

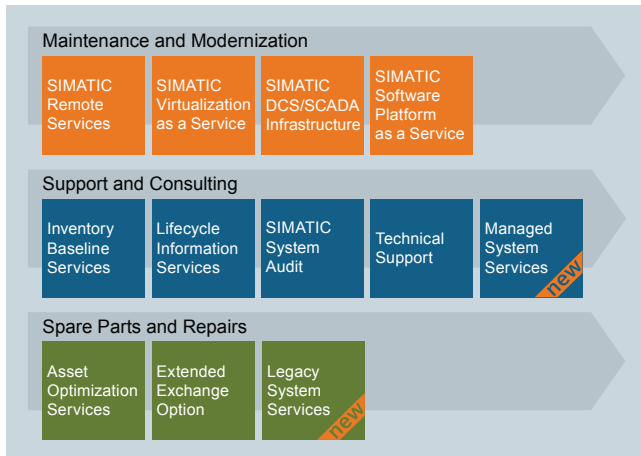

## SIMATIC PCS 7 Lifecycle Services

Only process control systems that can be updated/ upgraded throughout their entire lifecycle can keep pace with the ongoing development of system technology at reasonable costs.

Reactive, proactive and preventive lifecycle services ensure the service capability of the process control system at optimized costs throughout the entire lifecycle. They are a solid foundation for the protection of investment, assurance of system availability, the ability to plan the maintenance costs and cost-effective upgrades.

## Functional Safety Services

The safety lifecycle is divided into analysis, implementation and operation and it follows the lifecycle of the I&C systems. Operators of safety-related I&C systems, for example, chemical plants, refineries and distilleries and incinerators in accordance with IEC 61511 are obliged to verify the effectiveness of their protection measures in the safety lifecycle.

Selected services from the portfolio form the basis for personalized SIMATIC PCS 7 Lifecycle Service contracts that are reflected in typical contract profiles:

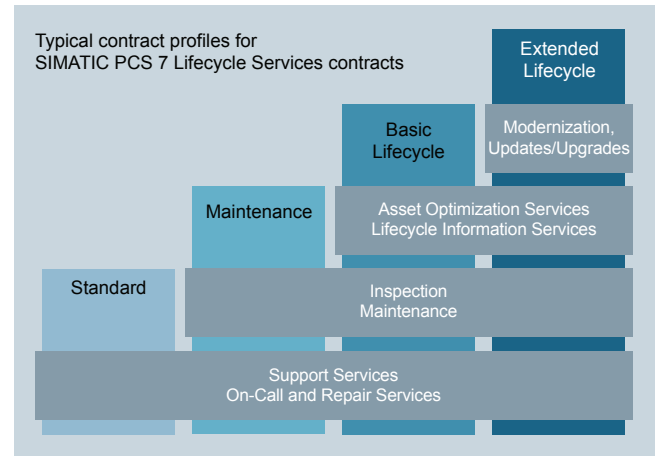

For additional information, see:  
[www.siemens.com/pcs7lcs](http://www.siemens.com/pcs7lcs)

**Siemens Industry, Inc.**  
100 Technology Drive  
Alpharetta, GA 30005 1-  
800-365-8766  
info.us@siemens.com

Subject to change without prior notice  
Order No.: PAFL-00167-0320  
All rights reserved  
Printed in USA  
© 2020 Siemens Industry, Inc.

The information provided in this brochure contains merely general descriptions or characteristics of performance which in case of actual use do not always apply as described or which may change as a result of further development of the products.  
An obligation to provide the respective characteristics shall only exist if expressly agreed in the terms of contract. Availability and technical specifications are subject to change without notice.

All product designations may be trademarks or product names of Siemens AG or supplier companies whose use by third parties for their own purposes could violate the rights of the owners.

## Security information

Siemens provides products and solutions with Industrial Security functions that support the secure operation of plants, systems, machines and networks.

In order to protect plants, systems, machines and networks against cyber threats, it is necessary to implement – and continuously maintain – a holistic, state-of-the-art industrial security concept. Siemens' products and solutions form only one element of such a concept.

Customers are responsible for preventing unauthorized access to their plants, systems, machines and networks. Systems, machines and components should only be connected to the enterprise network or the Internet if and to the extent necessary and with appropriate security measures (e.g. use of firewalls and network segmentation) in place.

Attention should also be paid to Siemens' recommendations on appropriate protective measures. For more information about Industrial Security, visit [www.siemens.com/industrialsecurity](http://www.siemens.com/industrialsecurity).

The products and solutions from Siemens undergo continuous development to make them even more secure. Siemens strongly recommends applying product updates as soon as they are available and always using the latest product versions. Using versions that are obsolete or no longer supported increases the risk of cyber threats.

To stay informed about product updates as they occur, subscribe to the Siemens Industrial Security RSS feed at [www.siemens.com/industrialsecurity](http://www.siemens.com/industrialsecurity).