

**SIEMENS**



FAQ-0H7B4HG0 • 09/2019

# Advantages of the integrated DC link reactor

SINAMICS Power Module PM240-2/PM240P-2, SINAMICS G120C and  
SINAMICS G120X



<https://support.industry.siemens.com/cs/ww/de/view/109749021>

This article originates from Siemens Industry Online Support. The terms of use specified there apply ([www.siemens.com/terms\\_of\\_use](http://www.siemens.com/terms_of_use)).

**Security  
informati  
on**

Siemens provides products and solutions with industrial security functions that support the secure operation of plants, systems, machines and networks.

In order to protect plants, systems, machines and networks against cyber threats, it is necessary to implement – and continuously maintain – a holistic, state-of-the-art industrial security concept. Siemens' products and solutions only form one element of such a concept.

Customers are solely responsible for preventing unauthorized access to their plants, systems, machines, and networks. Such systems, machines and components should only be connected to an enterprise network or the internet if and to the extent such a connection is necessary and only when appropriate security measures (e.g. firewalls and network segmentation) are in place.

Additionally, Siemens' guidance on appropriate security measures should be taken into account. For more information about Industrial Security, please visit <http://www.siemens.com/industrialsecurity>.

Siemens products and solutions undergo continuous development to make them even more secure. Siemens strongly recommends to apply product updates as soon as available and to always use the latest product versions. Use of product versions that are no longer supported, and failure to apply latest updates may increase customer's exposure to cyber threats.

To stay informed about product updates, subscribe to the Siemens Industrial Security RSS Feed under <http://www.siemens.com/industrialsecurity>.

## Table of contents

<b>1</b>	<b>Introduction.....</b>	<b>3</b>
1.1	Description .....	3
<b>2</b>	<b>Principle of operation and advantages .....</b>	<b>4</b>
2.1	Design .....	4
2.2	Advantages of the DC reactor.....	4
2.2.1	Limiting the peak value in the line current.....	4
2.2.2	Reduction of the line current harmonics.....	6
2.2.3	Smoothing the DC link voltage.....	7
2.3	What the DC reactor cannot do.....	7
<b>3</b>	<b>DC reactor versus AC reactor .....</b>	<b>8</b>
3.1	Differences in the harmonic behavior.....	8
3.2	Voltage drop .....	9
3.3	Input rectifier protection.....	10
3.4	Integration into the converter housing.....	10
3.5	Reduced phase asymmetry.....	10
3.6	Combining an AC reactor and a DC reactor .....	11
3.7	Service life of the DC reactor .....	11
3.8	Summary .....	11
<b>4</b>	<b>Operation on weak line supplies.....</b>	<b>12</b>
4.1	General information.....	12
4.2	Converter settings .....	12

# 1 Introduction

## 1.1 Description

The new PM240-2 Power Modules in FSD ... FSG, PM240P-2 Power Modules, SINAMICS G120C frequency converters in FSD ... FSF, as well as SINAMICS G120X frequency converters in FSA - FSG all have power units that are equipped with an integrated DC link reactor. This FAQ will explain the advantages of these DC link reactors as well as the differences to the AC reactors that were previously used.

For modular SINAMICS G120 frequency converters, this involves the PM240-2 Power Modules in frame sizes FSD ... FSG.

3AC200 ... 240V	FSD	11kW ... 18.5kW
	FSE	22kW ... 30kW
	FSE	37kW ... 55kW
3AC380 ... 480V	FSD	18.5kW ... 37kW
	FSE	45kW ... 55kW
	FSE	75kW ... 132kW
	FSG	160kW ... 250kW
3AC500 ... 690V	FSD	11kW ... 37kW
	FSE	45kW ... 55kW
	FSE	75kW ... 132kW
	FSG	160kW ... 250kW

For SINAMICS G120P frequency converters for pump and fan applications, it involves the PM240P-2 Power Modules in frame sizes FSD ... FSF.

3AC380 ... 480V	FSD	18.5kW ... 37kW
	FSE	45kW ... 55kW
	FSE	75kW ... 132kW
3AC500 ... 690V	FSD	11kW ... 37kW
	FSE	45kW ... 55kW
	FSE	75kW ... 132kW

For SINAMICS G120C frequency converters, it involves the devices, frame sizes FSD ... FSF.

3AC380 ... 480V	FSD	18.5kW ... 45kW
	FSE	55kW
	FSE	75kW ... 132kW

For SINAMICS G120X frequency converters for infrastructure projects, from frame size FSA the power units are already equipped with an integrated DC link reactor.

3AC380 ... 480V	FSA	0.75kW ... 3kW
	FSB	4kW ... 7.5kW
	FSC	11kW ... 15kW
	FSD	18.5kW ... 37kW
	FSE	45kW ... 55kW
	FSE	75kW ... 132kW
	FSG	160kW ... 250kW
3AC500 ... 690V	FSD	3kW ... 37kW
	FSE	45kW ... 55kW
	FSE	75kW ... 132kW
	FSG	160kW ... 250kW

## 2 Principle of operation and advantages

### 2.1 Design

As can be seen from Fig. 2-1, PM240-2 Power Modules in FSD ... FSG, PM240P-2 Power Modules, SINAMICS G120C frequency converters in FSD ... FSF and SINAMICS G120X, FSA to FSG have an LDC reactor integrated in the DC link; half of the inductance is in the positive arm of the DC link and the other half in the negative arm of the DC link.

Fig. 2-1 Topology of the PM240-2 Power Modules in FSD ... FSG, PM240P-2 Power Modules, SINAMICS G120C frequency converters in FSD ... FSF and SINAMICS G120X frequency converters in FSA - FSG

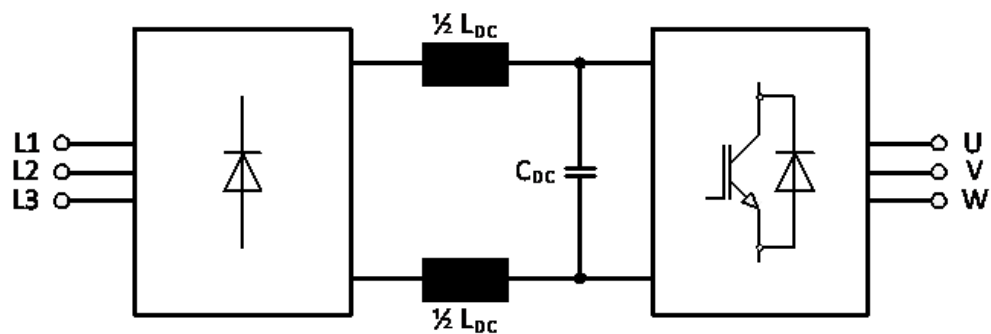

### 2.2 Advantages of the DC reactor

The integrated DC link reactor LDC has several advantages:

- It limits the peak value in the converter line current
- It reduces line current harmonics
- It smooths the DC link voltage

#### 2.2.1 Limiting the peak value in the line current

Frequency converters with their input rectifiers represent non-linear loads connected to the line supply. The current is not sinusoidal; depending on the line stiffness, DC link capacitance and upstream line reactor/DC link reactor, waveforms are obtained with a sinusoidal fundamental and a varying harmonic content. A 6-pulse rectifier bridge with DC link capacitance to feed the inverter is shown in Fig. 2-2

Fig. 2-2 6-pulse rectifier circuit with DC link capacitor

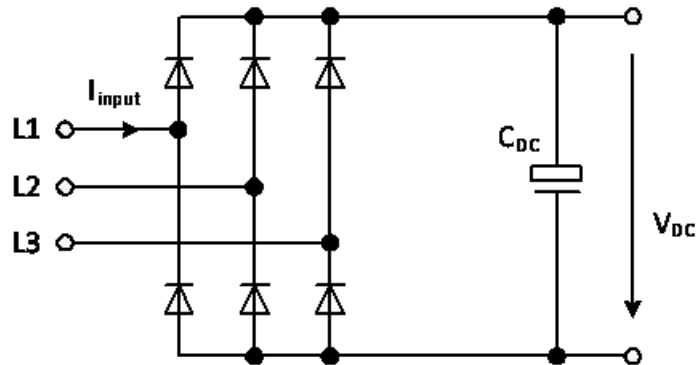

The following input current waveform is obtained for a line supply with short-circuit ratio  $RSC = 100$

Fig. 2-3 Referred (per unit) input current without AC reactor/DC reactor

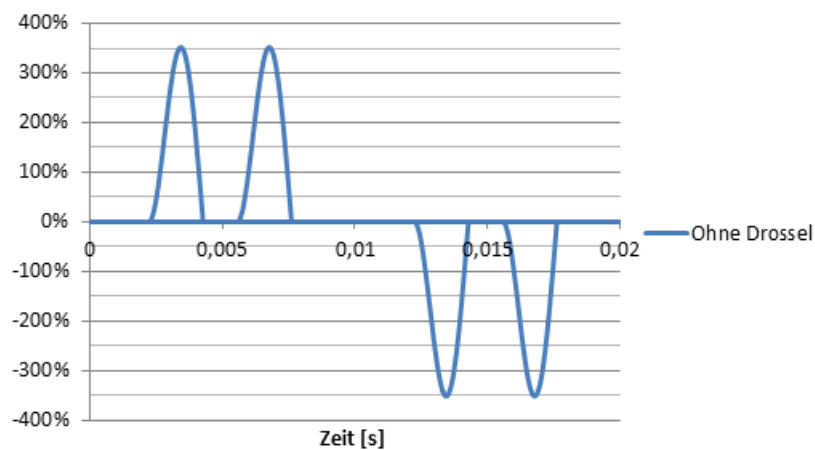

As can be seen from Fig. 2-3, the peak values of the input current represent up to 350% of the rated input current.

A reactor in the DC link delays the current rise and extends the current-conducting phase. This results in an almost square waveform, whose maximum peak value is 180% of the rated input current.

Fig. 2-4 6-pulse rectifier circuit with DC link capacitor and split DC link reactor

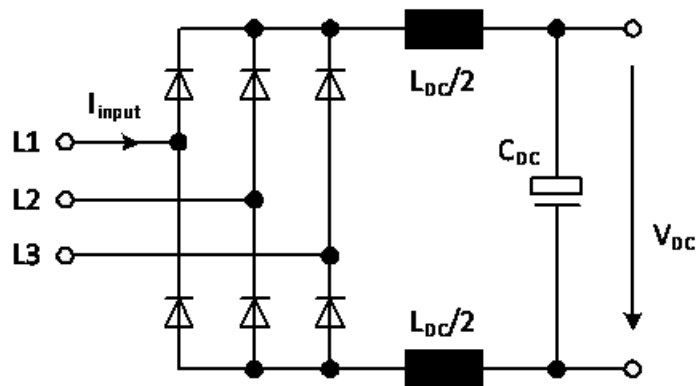
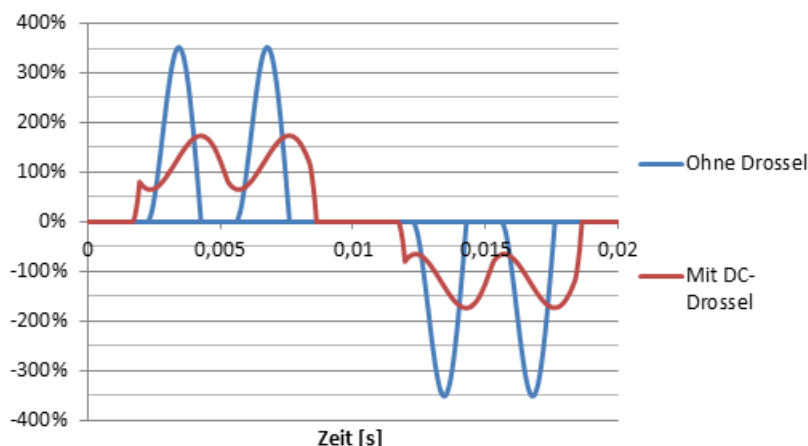

Fig. 2-5 Referred (per unit) input current with/without DC reactor



### 2.2.2 Reduction of the line current harmonics

The different current waveform with and without DC reactor not only affects the peak current, but also the harmonics in the input current.

Fig. 2-6 Comparison of the harmonic currents and harmonic current characteristic values with and without DC reactor

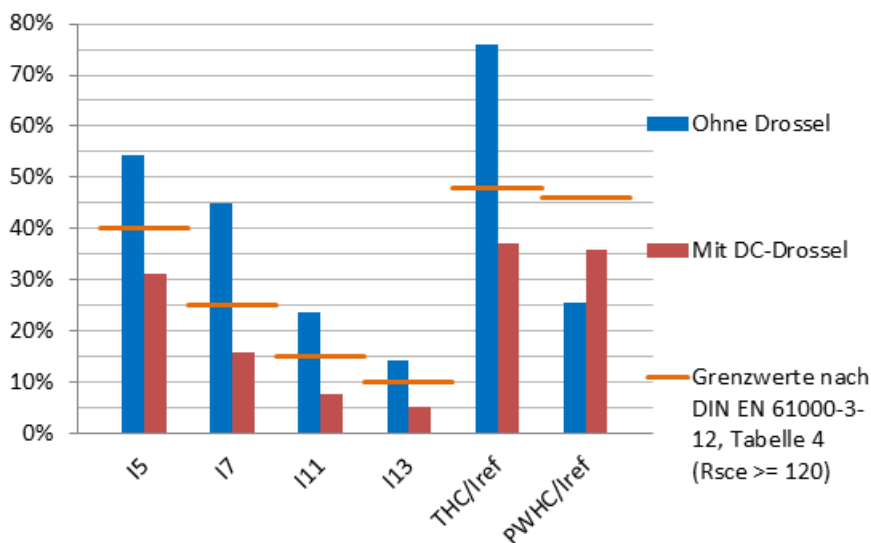

When operating frequency converters on the public grid, EN 61000-3-12 Table 4 lists limit values for the individual harmonics, the total distortion  $THC/I_{ref}$  and the weighted subharmonic current  $PWHC/I_{ref}$ . Seen strictly, EN 61000-3-12 is only applicable for devices with rated currents extending from 16A up to 75A; however, according to EN 61800-3, higher-rating systems up to 100kVA can also be evaluated.

Without a DC reactor, harmonics in the range between the 5th and the 13th harmonic can reach a value significantly above the permissible limit values according to EN 61000-3-12, Table 4; the value for the total distortion  $THC/I_{ref}$  also lies above the permissible limit value.

By using a DC reactor, the individual harmonics are reduced to values below the limit values listed in EN61000-3-12, Table 4. The value for the referred (per unit) harmonic current  $THC/I_{ref}$  also lies below the limit value. The value for the weighted partial harmonic current  $PWHC/I_{ref}$  increases by 10%; however, it lies significantly below the permissible limit value. This increase is as a result of the fast increase of the input current, which results in significantly more harmonics in the range from the 14th to the 40th harmonic.

### 2.2.3 Smoothing the DC link voltage

The DC link voltage with and without DC reactor, referred to an ideal DC link voltage of  $U_{DI} = 1.35 \cdot U_{line}$ , is shown in Fig. 2-7. Without a DC link reactor, an rms value of 546V is obtained; however, the DC link voltage fluctuation with  $\pm 5\%$  is also more significant. By using the DC link reactor, the DC link rms voltage drops down to 534V; however, the DC link voltage fluctuation is now only  $\pm 1.5\%$ , which results in lower power semiconductor losses.

Fig. 2-7 DC link voltage referred to an ideal DC link voltage of  $U_{di} = 1.35 \cdot U_{line}$

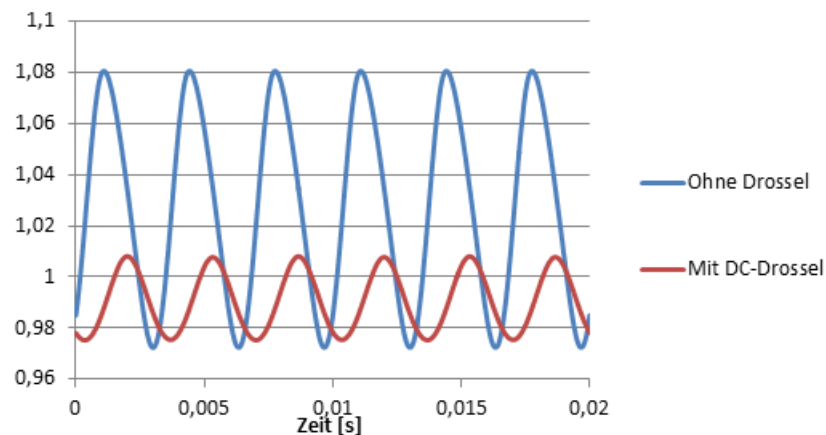

## 2.3 What the DC reactor cannot do

The DC reactor is not a substitute for an output reactor; i.e. it is not responsible in ensuring that longer cable lengths can be used with the new Power Modules without using an output reactor. The only reason for this (longer cable lengths) is that higher-rating IGBTs are used. Output reactors must still be used for cables longer than 200m shielded for FSD and FSE – or 300m shielded for FSF and FSG. Further, the DC reactor does not reduce the current rate of rise at the motor winding; i.e.  $du/dt$  filters must be used if the motor winding is not capable of converter operation.

Compliance with the limit values for cable-conducted interference voltages and field-emitted interference according to Category C2 of EN 61800-3 for a cable length of 150 meters is as a result of the improved line filter.

### 3 DC reactor versus AC reactor

In the previous generation of frequency converters, such as MICROMASTER, MASTERDRIVES and also SINAMICS, only AC reactors were used on the line side of the frequency converters. The differences between the two reactor concepts, as well as the advantages and disadvantages, will now be subsequently described.

#### 3.1 Differences in the harmonic behavior

The difference in the characteristic of the input current between the DC reactor and a 2% AC reactor, as was previously available in the PM240/PM240-2 program, is shown in Fig. 3-1. The DC reactor has a lower peak current value and also lower harmonic values than the 2% AC reactor. Only the value for the weighted partial harmonic current PWHC/Iref increases by 13%; however, it lies significantly below the permissible limit value. This increase is as a result of the fast increase of the current characteristic, which results in significantly more harmonics in the range from the 14th to the 40th harmonic.

Fig. 3-1 Referred (per unit) input current with AC reactor/with DC reactor

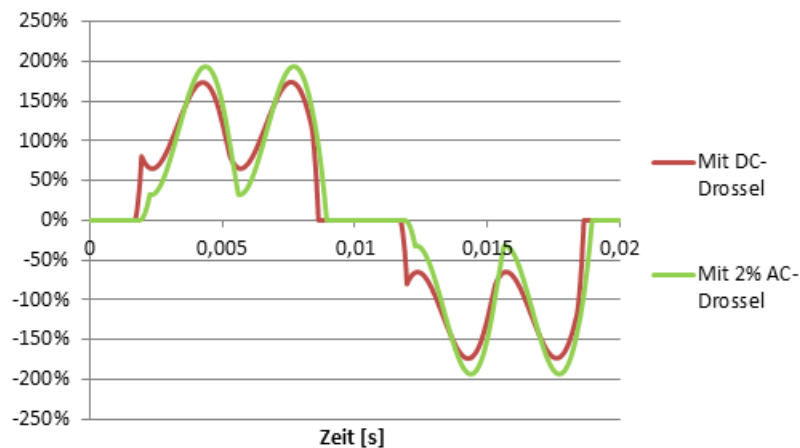

Regarding the harmonic behavior, the DC reactor behaves just like an AC reactor with 3%; i.e. for applications where a 3% AC reactor is specified, in addition to the existing DC reactor, an additional AC reactor is not required.



Fig. 3-2 Comparison of the harmonic currents and harmonic current characteristic values without reactor, with AC reactor and with DC reactor

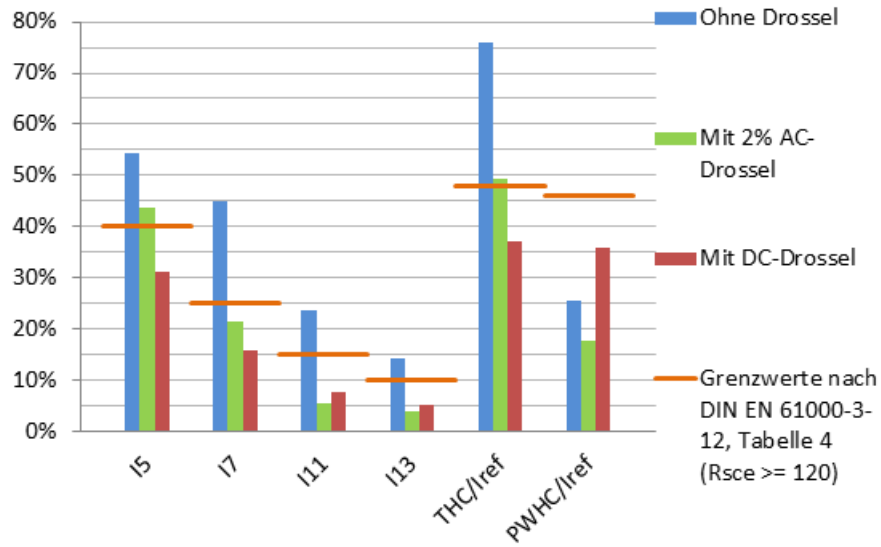

### 3.2 Voltage drop

With 2%, the voltage drop of an AC reactor is higher than the voltage drop of the integrated DC reactor. This means that the DC link rms voltage is only 526V compared to 534V with the DC reactor. As a consequence, the DC reactor has the advantage that the inverter output voltage increases from 95% to 96%.

Fig. 3-3 DC link voltage referred to the ideal DC link voltage  $U_{di} = 1.35 \cdot U_{line}$  with AC reactor and DC reactor

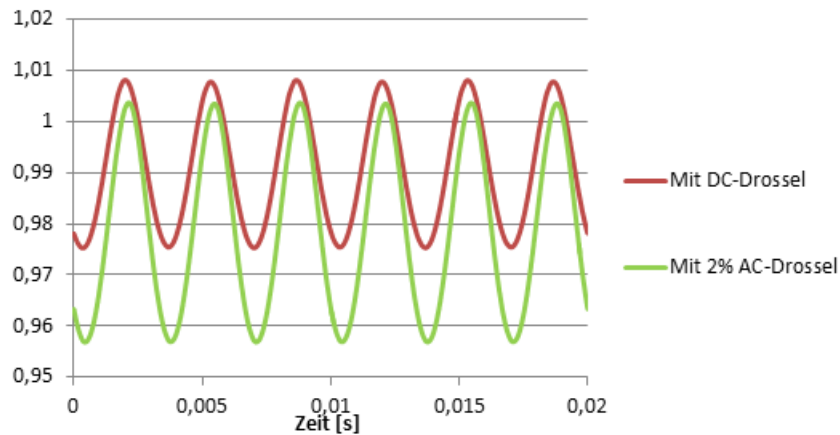

### 3.3 Input rectifier protection

AC reactors were previously used to protect the rectifier with respect to overvoltages due to transient switching operations and commutation dips resulting from converter operation.

PM240-2 Power Modules in FSD ... FSG, PM240P-2 Power Modules, SINAMICS G120C frequency converters in FSD ... FSF and SINAMICS G120X frequency converters in FSA ... FSG are designed to be directly connected to the line supply. As guide value for the noise/interference immunity, the requirements laid down in standard EN 61800-3:12.2004 and test standard EN 60146-1-1:2010 should be applied. According to EN 61800-3, the Power Modules are immune to noise and interference according to Category C3, which means:

Interference immunity with respect to harmonics according to IEC 61000-2-4 Class 3 with a level of 12%, assumption criterion A

Interference immunity with respect to individual harmonics according to IEC 61000-2-4 Class 3, assumption criterion A

Interference immunity with respect to commutation dips according to IEC 60146-1-1 Class B, level with depth = 40 %, overall area = 250 % in % degrees, assumption criterion A

Voltage deviations (>60s) IEC 61000-2-4 Class 2, assumption criterion A

Voltage dips and brief interruptions according to IEC 61000-4-11/ IEC 61000-4-34, assumption criterion C

Further, the Power Module input rectifiers have been upgraded so that they can be directly connected to the line supply:

- The rectifier modules have a higher voltage strength when compared to the predecessor devices. For the 400 V devices, the voltage strength is now 1.6kV instead of 1.2kV, for the 690V devices, 2.2kV instead of 1.8kV.
- Varistors and capacitors are used as protection against transient overvoltages (surge voltages).

### 3.4 Integration into the converter housing

The DC reactor can be installed in the converter housing in a relatively space-saving fashion. This is because it only has a few connections when compared to an AC reactor, which has connections for the three phases. However, you must take into account that the integrated DC reactor increases the converter weight.

### 3.5 Reduced phase asymmetry

An AC reactor has the advantage that it can reduce the asymmetry of the current phases in the input current. A DC reactor cannot be used to compensate this asymmetry.

## 3.6 Combining an AC reactor and a DC reactor

For requirements relating to low harmonics, using a line reactor with 5%, you can add an additional 2% AC reactor to the Power Module equipped with a DC reactor (comparable with a 3% AC reactor). However, it is important that the line inductance does not become too high as a result (see Chapter 4).

## 3.7 Service life of the DC reactor

An identical service life as for the predecessor series was a criterion when it came to designing and dimensioning the PM240-2 Power Modules in FSD ... FSG, PM240P-2 Power Modules, SINAMICS G120C frequency converters in FSD ... FSF and SINAMICS G120X frequency converters in FSA ... FSG. The DC link was appropriately dimensioned. As a consequence, PM240-2 Power Modules in FSD ... FSG, PM240P-2 Power Modules, SINAMICS G120C frequency converters in FSD ... FSF and SINAMICS G120X frequency converters in FSA ... FSG do not have a shorter service life than the predecessor devices with AC reactor.

The DC reactors in the PM240-2 Power Modules in FSD ... FSG, PM240P-2 Power Modules, SINAMICS G120C frequency converters in FSD ... FSF and SINAMICS G120X frequency converters in FSA ... FSG are manufactured out of laminated sheet steel. The properties of sheet steel laminations do not deteriorate with age. As a consequence, the harmonic behavior of DC reactors does not diminish over time.

## 3.8 Summary

The advantages of the DC reactor include:

1. The DC reactor reduces the harmonics in the line current better than an AC reactor with 2%.
2. The voltage drop is lower than that of an AC reactor. Typically, a DC reactor has a voltage drop of 1% compared to a three-phase AC reactor with a voltage drop of 2% or even more. The difference is manifested in a higher inverter output voltage.
3. The lower input current has a positive impact when it comes to dimensioning cables and fuses. An additional line reactor does not have to be used for applications involving stiff line supplies ( $u_k \leq 1\%$ ).

The disadvantages of the DC reactor include:

4. Higher converter weight.
5. No reduction in the phase asymmetry in the input current.

## 4 Operation on weak line supplies

### 4.1 General information

The actual inductance of a line supply depends on the transformer inductance. Stiff systems have a low inductance and/or low cable impedance, weak systems have a high inductance or high cable impedance. High line supply inductance levels limit the dynamic response of the drive when the motor load suddenly changes, as the current rate of rise is limited.

PM240-2 Power Modules in FSD ... FSG, PM240P-2 Power Modules, SINAMICS G120C frequency converters in FSD ... FSF and SINAMICS G120X frequency converters in FSA ... FSG have an integrated DC reactor. As a result, in weak systems, there is the risk of an oscillating circuit been created between the line inductance, DC link reactor and the DC link capacitors. In this case, the DC link voltage has a high amount of ripple (far higher than the 5% ripple that is permissible in normal operation). This reduces the performance of the drive, or even shuts down (trips) the converter as the overvoltage or undervoltage limits are reached.

Section 4.2 describes how disturbance-free operation is possible under the specified general conditions of the supply systems – and how you can handle oscillations that occur in operation.

### 4.2 Converter settings

Line supplies/supply systems with a short-circuit rating  $RSCE = 25$  or higher represent a normal operating environment for PM240-2 Power Modules in FSD ... FSG, PM240P-2 Power Modules, SINAMICS G120C frequency converters in FSD ... FSF and SINAMICS G120X frequency converters in FSA ... FSG; they have been designed for these types of environments.

With U/f control ( $p1300 = 0$ ), the devices can be operated on line supplies with a short-circuit rating of  $RSCE = 10 \dots 12.5$ .

With vector control ( $p1300 = 20$ ) and with U/f control, the devices can be operated on line supplies with a short-circuit rating of  $RSCE = 12.5 \dots 17$ .

When connected to weak line supplies, the following measures must be taken if oscillations occur during operation at the maximum current:

- The calculation of the DC voltage compensation performed by the Power Module ( $p1810 = 0$ , default) must be switched over to the calculation performed by the Control Unit ( $p1810 = 2H$ ). The calculation using the Control Unit is slower than when using the Power Module, i.e. disturbances are filtered out, and not taken into consideration to the same extent.
- The maximum current must be reduced, any overload must be reduced.

It does not make any sense to use an additional line reactor to reduce oscillations, as an additional reactor makes the line supply system even weaker, therefore increasing oscillations.