

REVISIONS				
REV	ECN/MCR	DESCRIPTION	DATE CHANGED BY	APPROVED BY
OP		INITIAL PRELIMINARY RELEASE	02-25-15	M. Rodr

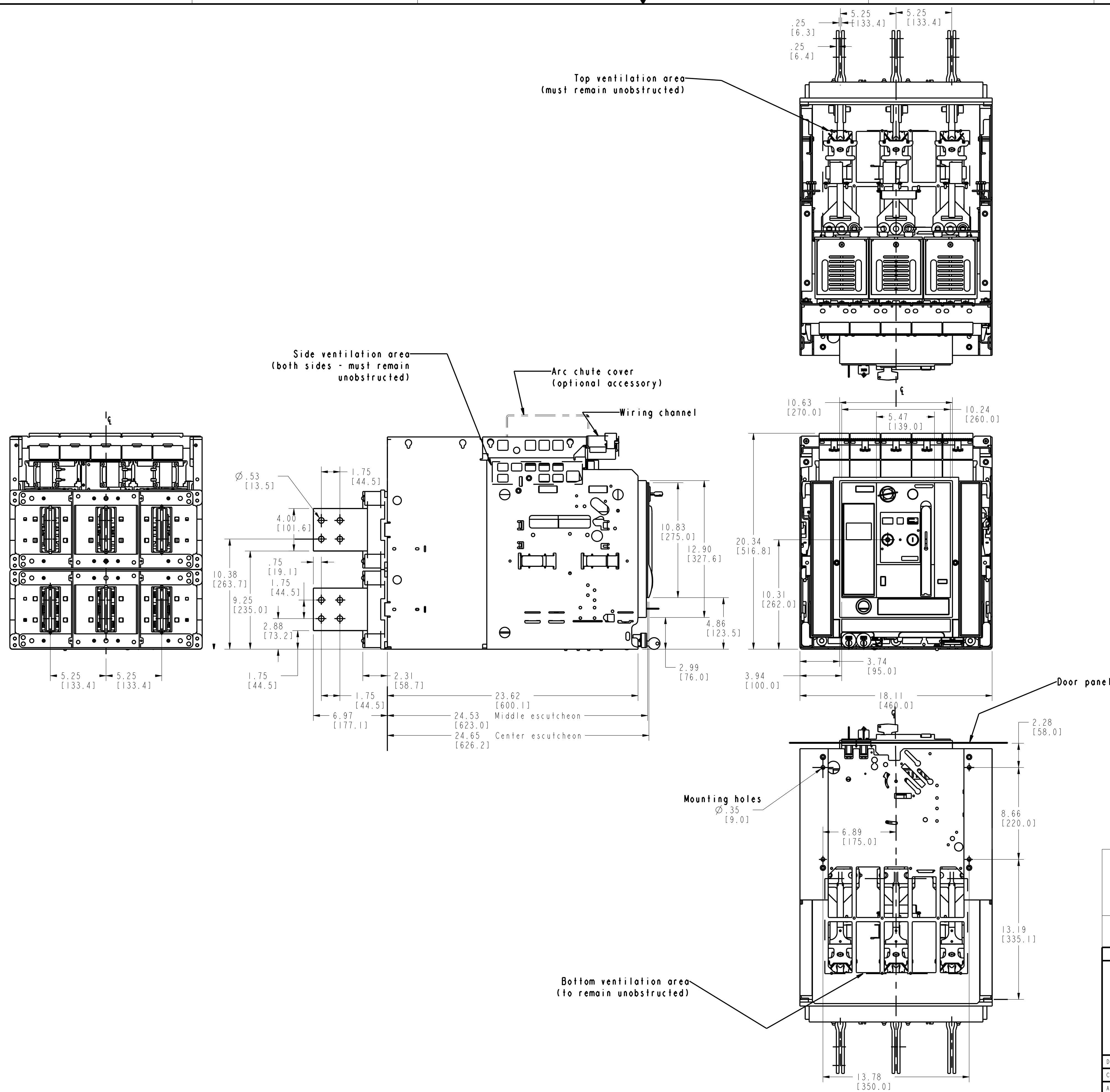

814886	Drawing applicable for the following frames WLF2A30A, WLF2A30B, WLF2A30C, WLF2A30D, WLF2A30E, WLF2A30F, WLF2A30G, WLF2A30H, WLF2A30J, WLF2A30K, WLF2A31A, WLF2A31B, WLF2A31C, WLF2A31D, WLF2A31E, WLF2A31F, WLF2A31G, WLF2A31H, WLF2A31J, WLF2A31K, WLF2A32A, WLF2A32B, WLF2A32C, WLF2A32D, WLF2A32E, WLF2A32F, WLF2A32G, WLF2A32H, WLF2A32J, WLF2A32K.			
PART OR IDENTIFYING NO.	MATERIAL/SPECIFICATION			
CONFIDENTIAL - PROPERTY OF Siemens Industry, Inc.				
Siemens Industry, Inc.				
UL 1066 FS2 Drawout 3P 3WL Class F				
UNLESS OTHERWISE SPECIFIED DIMENSIONS ARE IN INCHES DO NOT SCALE DRAWING				
TOLERANCES: .X ± .01 .XXX ± .005 ANGULAR ± 1.00				
DWN M. Rodr	DATE 02-25-15	SIZE D	FSCM NO.	DWG NO. 814886
CHK S. Puppala	DATE 3/2/15			REV. OP
APVD K. Flowers	DATE 3/6/15	SCALE 1:5	PROJ FILE 814886	SHEET 1 OF 2

REVISIONS				
REV	ECN/MCR	DESCRIPTION	DATE CHANGED BY	APPROVED BY
OP		See First Page for Description of Changes	02-26-15	M. Rodr

Door cut-out (with edge protector)
(Cut-out after mounting edge protector)

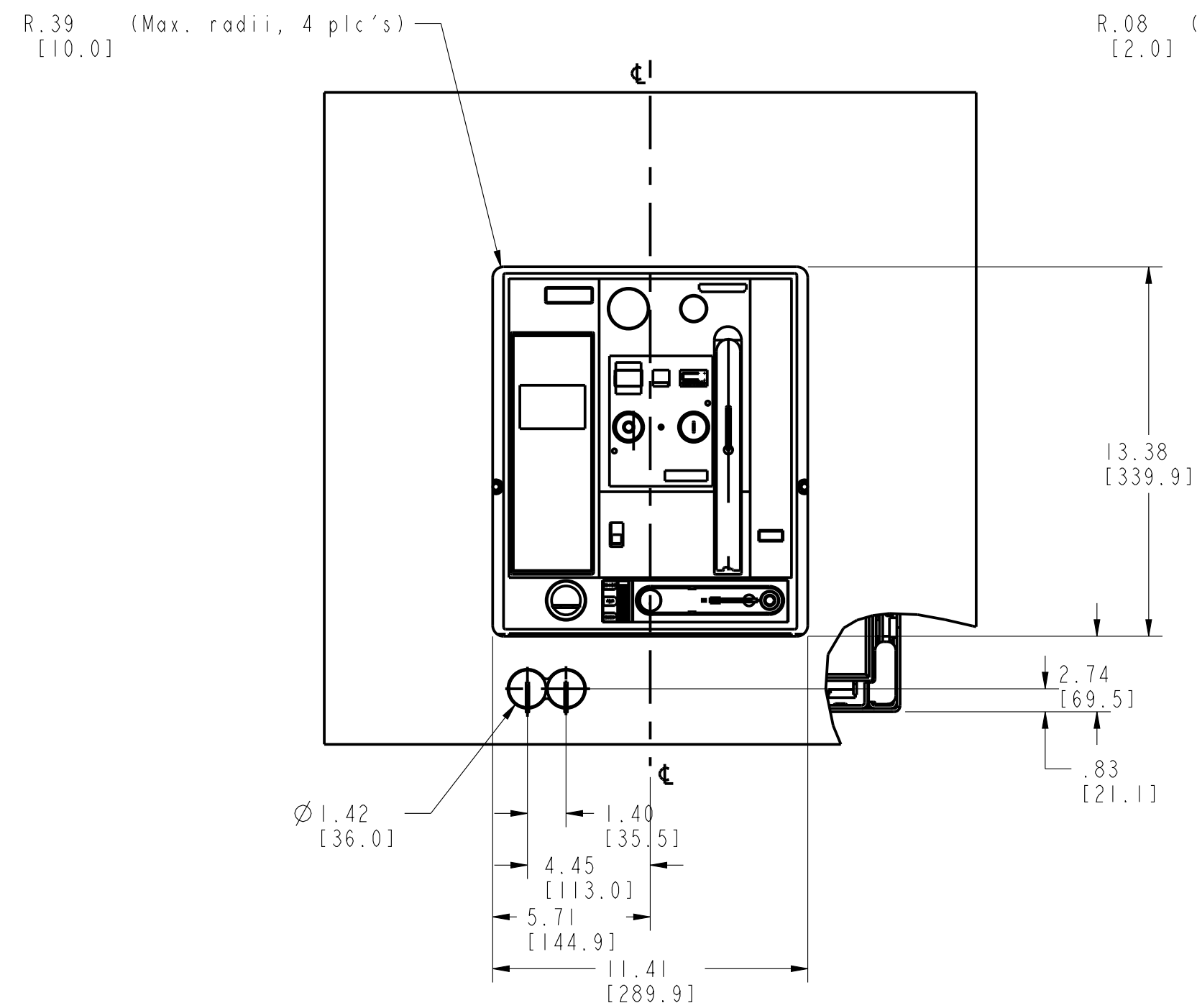

Door cut-out
(Middle escutcheon visible)

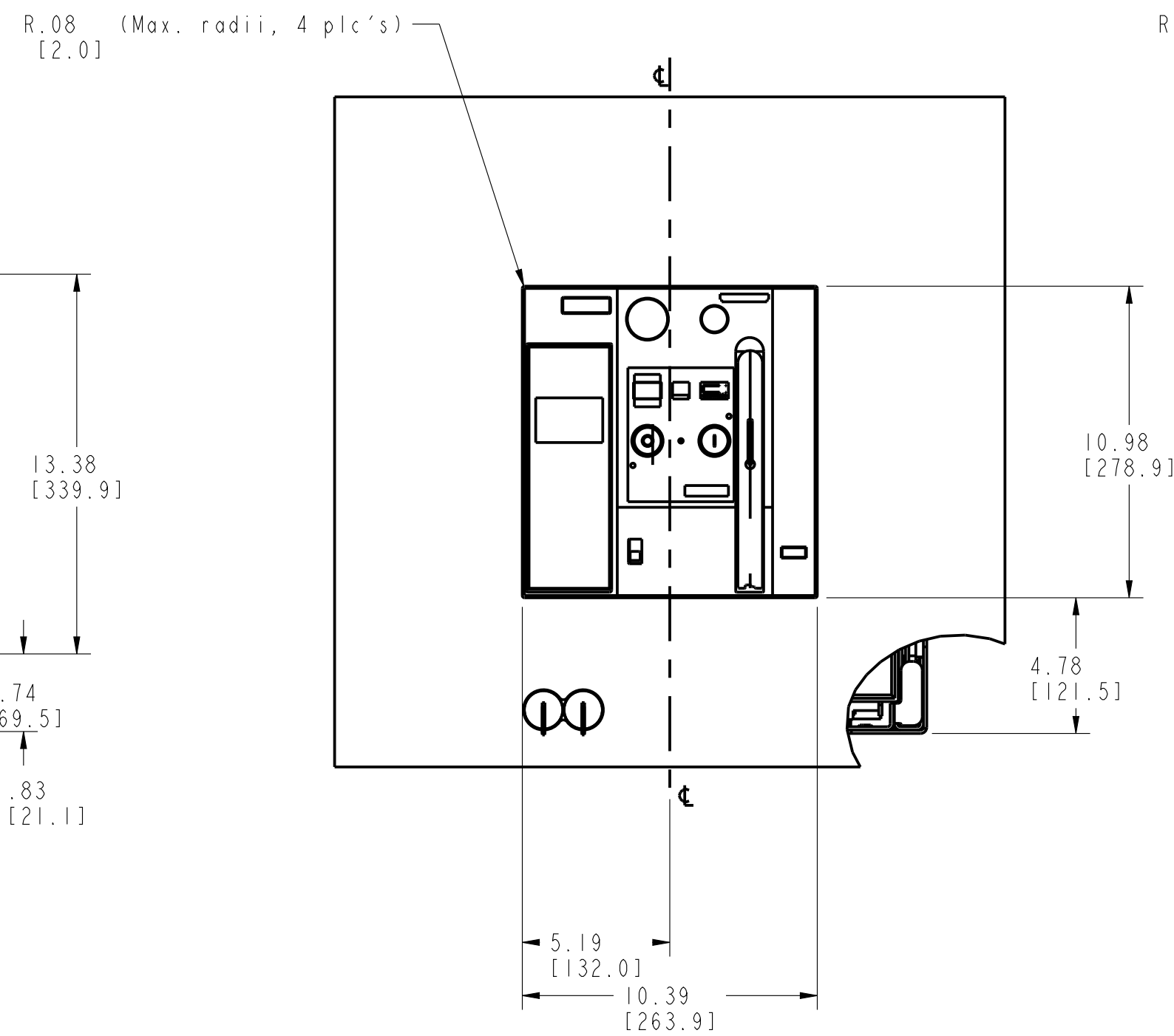

Minimal door cut-out
(Only center escutcheon visible)

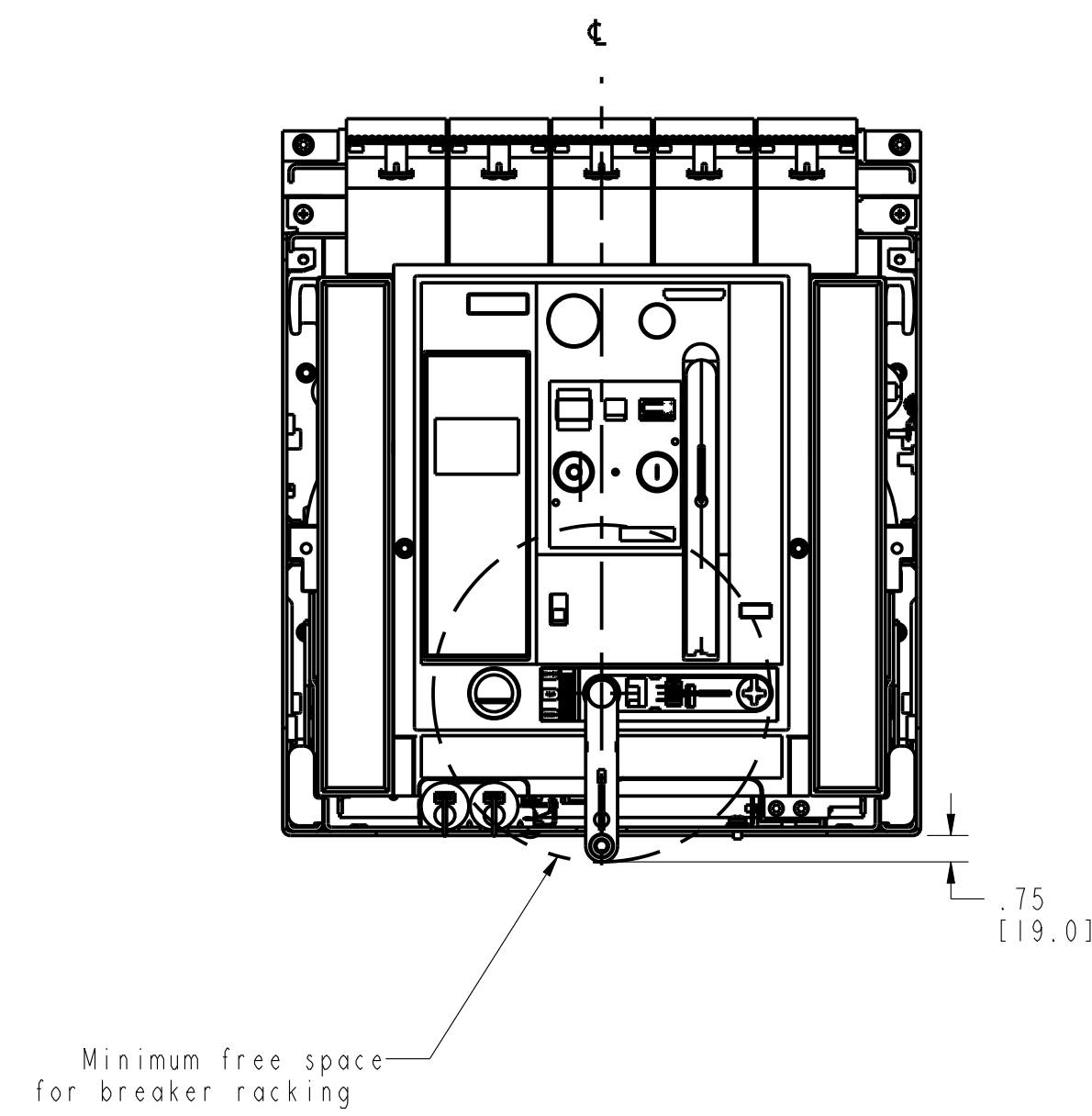
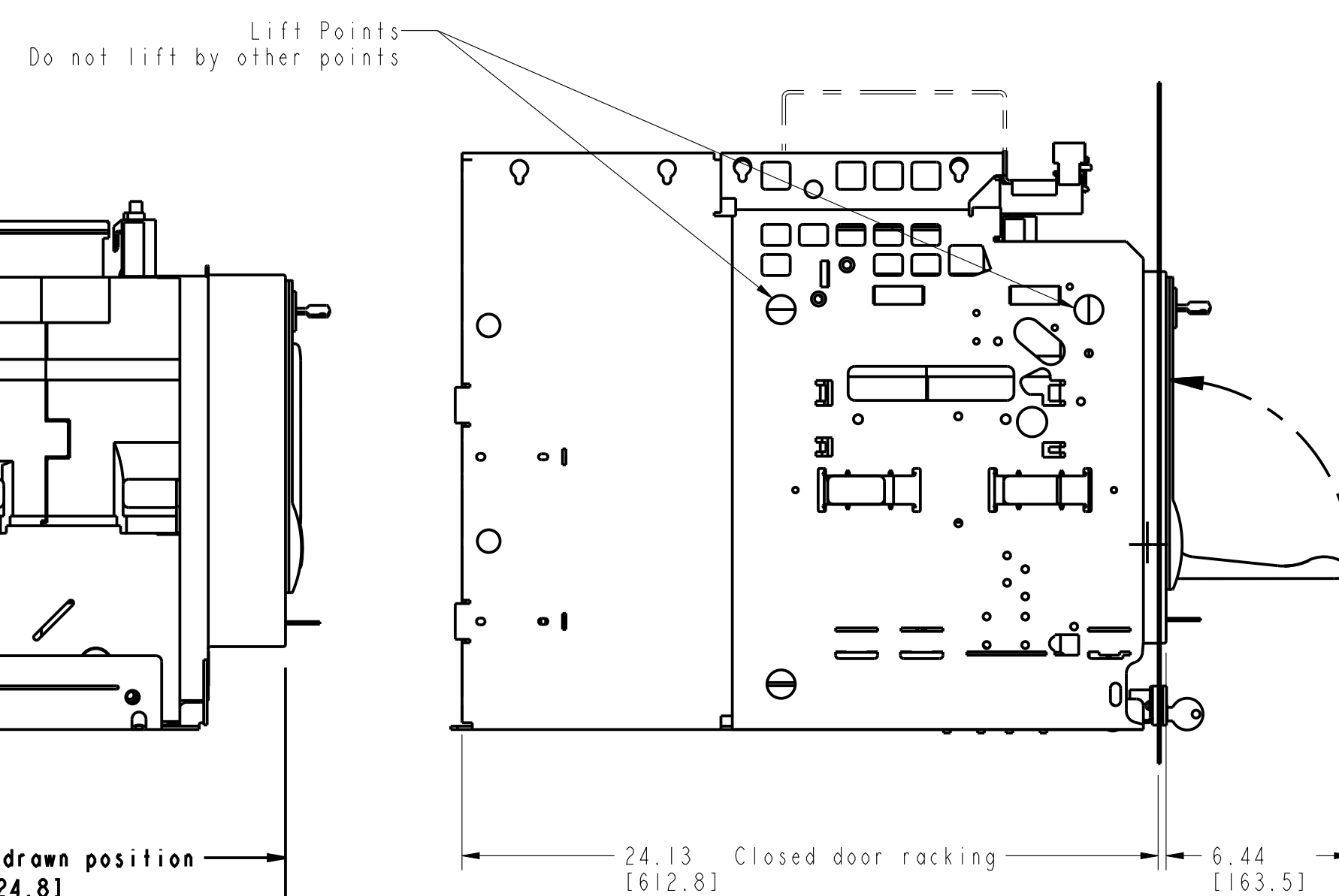
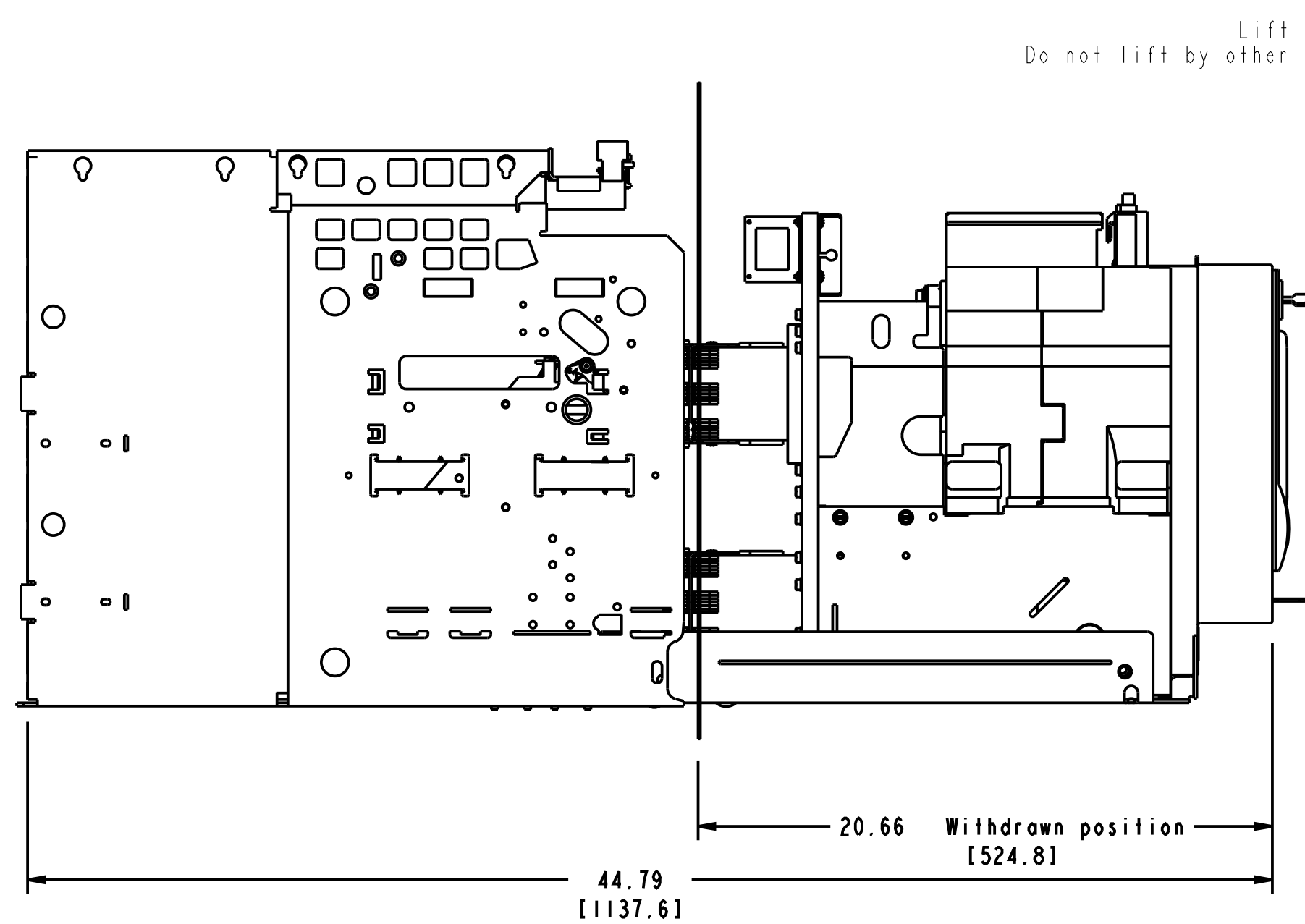
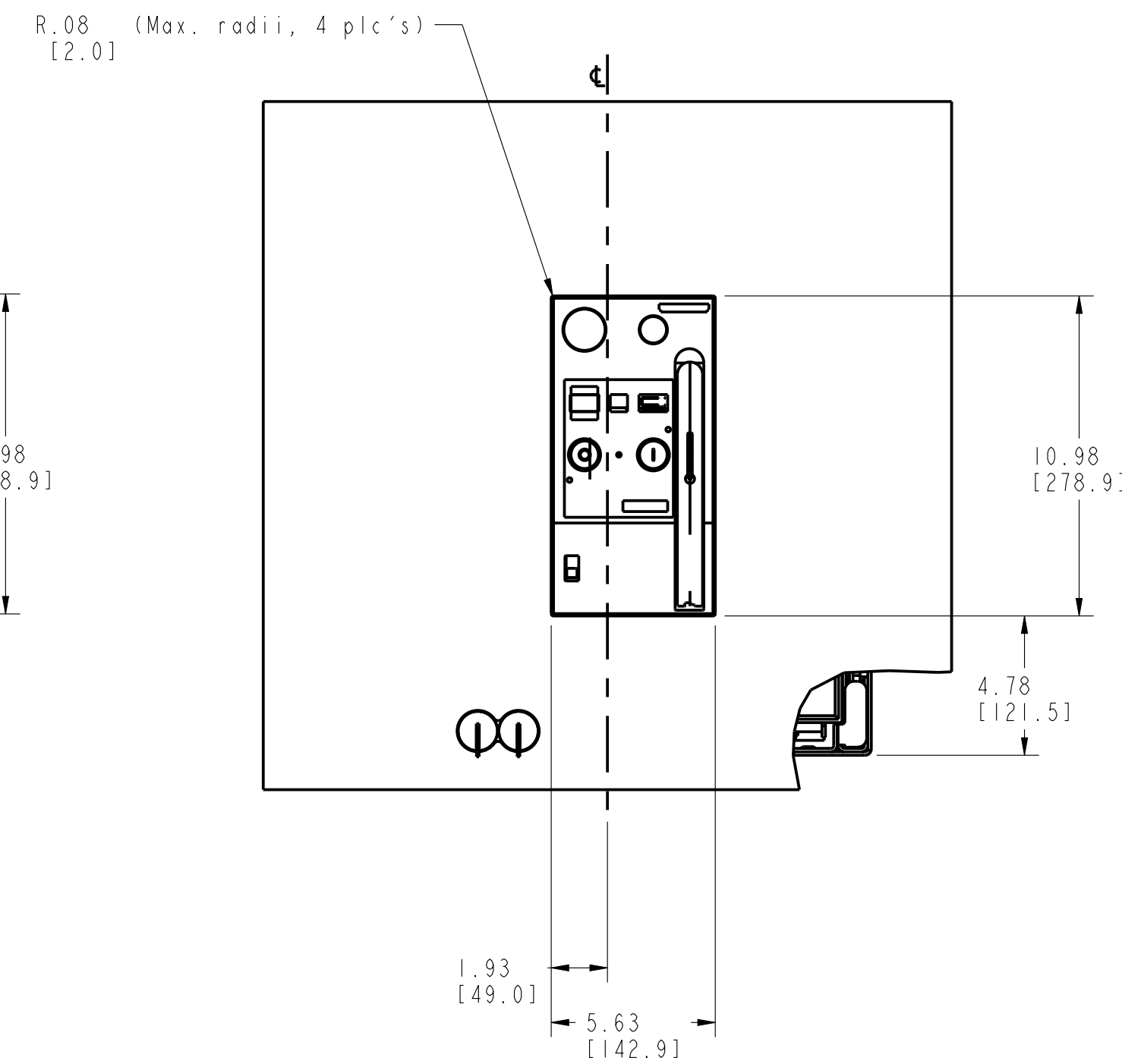

Lift Points
Do not lift by other points

Minimum free space
for breaker racking

PART OR IDENTIFYING NO.		MATERIAL/SPECIFICATION			
CONFIDENTIAL - PROPERTY OF Siemens Industry, Inc.					
Siemens Industry, Inc.					
UL 1066 FS2 Drawout 3P 3WL Class F					
UNLESS OTHERWISE SPECIFIED DIMENSIONS ARE IN INCHES DO NOT SCALE DRAWING		TOLERANCES:			
.X1 ± .01		THIRD ANGLE PROJ.			
.X11 ± .005		DWN M. Rodr DATE 02-25-15 SIZE FSCM NO. DWG NO. 814886 REV. OP			
ANGULAR ± 1.00		CHK S. Puppala DATE 3-2-15			
APVD K. Flowers DATE 3-6-15		SCALE 1:5		PROJ FILE 814886 SHEET 2 OF 2	