

GAMMA instabus

Touch control TC5

5WG1205-2AB21



Multi-functional display and control unit with KNX S-Mode

- Operation via 5 inch color touch screen
 - Control of light, blinds and scenes
 - Room temperature PI controller and/or ventilation
 - Interface and operation for VRF devices (VRF: Variable Refrigerant Flow)
 - Display of temperature, humidity, air quality, energy metering value, etc.
- Schedule, event management and basic logic function
- Configurable navigation for up to 15 function pages
- Administrator function via password or bus objects
- Proximity sensor, adjustment of screen brightness, buzzer
- Customization possible for wall paper, screen saver, and configurable icons

Touch control TC5 (hereinafter refer to as TC5) is a KNX S-Mode multi-functional touch panel for display, operation and control use. The device is equipped with a 5-inch color capacitance touch screen with 480 × 854 resolutions.

The device is powered over KNX together with the DC 24...30 V auxiliary supply voltage.

It is operated directly via touch screen. Totally up to 15 function pages and 2 home pages can be configured via ETS (ETS5.7 or later version).

Functionalities:

- Home page for navigation purpose
TC5 can set up multiple function pages for control and operation use. To easily navigate to the desired function page, there are max. 2 home pages with up to 8 icons per page. The navigation function can be enabled/disabled. If it is disabled, only one cover page is available showing the date, time and temperature without home page.
- Multi-function page for lighting, blind, scene and value sending function
Lighting control includes switching and dimming. Blind function covers curtain type open/close blind, roller shutter type up/down blinds and venetian blind with louver angles adjustment. Scene operation such as scene recall via short press the scene icon and storage via long press the scene icon is allowed. Upon demand, up to 120 channels are available for each individual function.
- HVAC control covers several applications:
 - General temperature control applies for many room heating / cooling applications such as FCU, chilled ceiling with 2-point or PI control. It can manage the room temperature with setpoint (absolute or relative), heating / cooling selection, fan operation (2 options: When fan operation is disabled, it is completely invisible; When it is enabled, there are 5 types of fan speed: 3-speed, Off and Auto.), operation mode changes (4 modes: Comfort, Standby, Economy and Protection).
 - VRF (Variable Refrigerant Flow) interface allows TC5 to act as the user interface to operate VRF or VRV (Variable Refrigerant Volume) air conditioning devices with a VRF gateway.
 - Enhanced floor heating control has dedicated timer and scene function. There is indication of heating valve on/off and timer operation on screen.
 - Ventilation control has manual 3-speed fan switchover as well as auto control (demand-based ventilation) via PM2.5 or CO₂ value. It supports opening/closing of heat recovery, filter life counting, alarm for filter change and filter life reset.

Up to 10 pages can be configured as HVAC control.
- Display air quality value from bus
This page can display various sensor readings such as temperature, relative humidity, PM2.5, PM10, CO₂, VOC, AQI, brightness and wind speed. Up to 4 parameters can be displayed on one page and totally up to 10 pages can be configured as display page.
- Display energy metering value from bus
Up to 8 meters can be displayed on one page and totally up to 10 pages can be configured as display page.
- Timer (schedule) function
Up to 16 schedules can be set. The schedule can be either daily or weekly and it is configured via ETS.
- Event management
Up to 8 sets of event functions are available for setting. Up to 8 output telegrams can be triggered by calling the scene number. Each output has 3 different data type options.
- Logic functions
There are up to 8 logic inputs configurable with logic capabilities of doing AND, OR, and XOR, gate forwarding, threshold comparator and format conversion.
- RGB, RGBW control and color-temperature adjustment
TC5 can set up dimming control page for 4 types of color lights, which are 3-color RGB light, 4-color RGBW light, 4-color RGBW light optional with color temperature adjustment and brightness & color temperature adjustment.
- Display time, date, temperature, output day/night signal
- Proximity sensor, adjustment of screen brightness, buzzer

- Administrator function via password
It is configurable. Maximum 3 passwords are available.
- Administrator function via bus
The whole device or selected function pages can be locked to disable user screen operation.
- Multi-usage color strip
The color strip is designed not only as a decoration, but also for multiple indication usage, such as indication of KNX programming mode, seasonal changes and alarm information.
- On site customization possible for theme (wallpaper), screen saver, and configurable icons

Type summary

Product no.	Stock no.	Description	Operating voltage
UP 205/21	5WG1205-2AB21	5" touch panel, vertical	DC 24...30 V

Accessories

No.	Product	Description
1	Mounting plate	For fitting onto a conduit box ¹⁾
2	Screws ²⁾	Only for China market

Note:

¹⁾ Conduit box needs to be ordered separately.

²⁾ #6/32 flat head machine screw is for US market.

Ordering

When ordering, specify product quantity, product number / stock number and name: e.g. UP 205/21 (5WG1205-2AB21) 5" touch panel.

Product documentation

Title	Document ID
Mounting instructions	A6V11980235
Application manual	A6V12035440
CE declaration	A5W00138763A
RCM declaration	A5W00138764A
Environmental product declaration	A5W00137325A

Related documents such as environmental declarations, CE declarations, etc., can be downloaded at the following Internet address:

<http://siemens.com/bt/download>

Technical documentation and ETS application can be downloaded at <http://www.siemens.com/gamma-td> (S-Mode).



To search for the technical documentation, you can enter the product type in <http://www.siemens.com/gamma-td>.

Mechanical design

The device consists of the following parts:

- Touch panel with electronics, operating elements and built-in room temperature sensor
- Mounting plate is an additional part to complete the installation for 5WG1205-2AB21

Operation and display

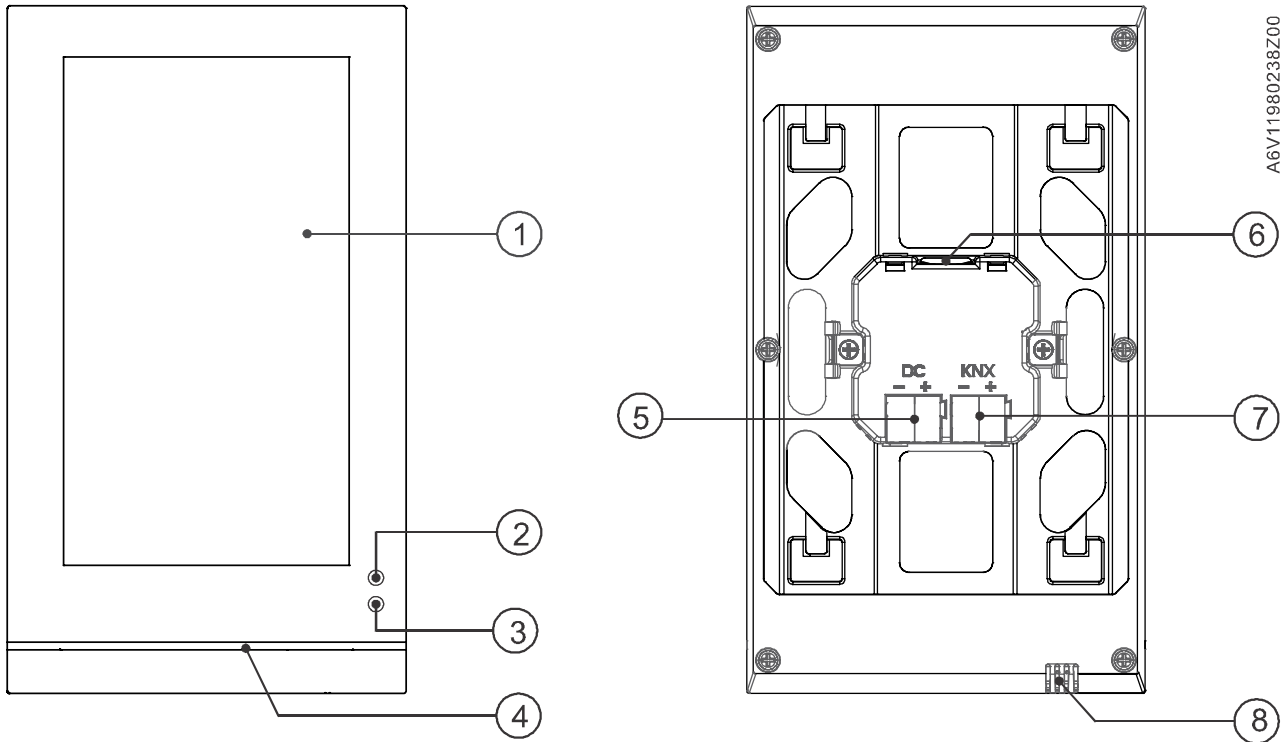

No.	Product description	No.	Product description
①	Display and touch operation area	⑥	Micro SD card slot
②③	Proximity sensor	⑦	KNX bus connection terminal
④	Color light strip	⑧	Built-in temperature sensor
⑤	Auxiliary power supply connection terminal		

Note

- Entering programming mode:
 - Click the setting icon  in home page;
 - Goes to "General";
 - Enable "KNX programming", then the colorful strip turns red and device can be configured via ETS.
- KNX programming function need to be done by professional engineers. Make sure this function is disabled during daily operation and if it is enabled:
 - The device can operate normally.
 - The color strip is constant red and it affects the strip life span.
- Micro SD card is used for modifying the background picture, electronic photo album, icons for home page or multi-functional pages. SDHC card and FAT32 format are only supported and the capacity of Micro SD cards is not greater than 32 GB.

Security

	<p>⚠ CAUTION</p>
	<p>National safety regulations Failure to comply with national safety regulations may result in personal injury and property damage.</p> <ul style="list-style-type: none"> • Observe national provisions and comply with the appropriate safety regulations.

Engineering

	<p>⚠ WARNING</p>
	<p>When designing and constructing the system, be sure to adhere to the installation and operation guidelines for the product, and comply with relevant national laws and regulations strictly.</p>

Mounting and installation

Mounting

- The device is suitable for semi-flush mount.
- The device must be installed and debugged by a professionally-trained and authorized engineers.
- Keep devices away from strong magnetic field, high temperature and wet environment.
- Do not fall the device to the ground and avoid hard impact.
- Do not use wet cloth or volatile reagent to wipe the device.
- Do not disassemble the device.

Wiring

- Equipped with protective features against over-voltage, over-current, short circuit and reverse polarity in the power supply.
- All connectors must be soldered using tin wires. Otherwise, resistance will be generated in the contacts over time which cause unstable operation.
- The device is powered with direct current. Avoid reversing the positive and negative poles of the power supply.
- When connecting the device, ensure that the device is properly insulated.

Commissioning

- Power supply is KNX with a DC 24...30 V auxiliary supply voltage.
-  During the process of modifying the wall paper, screen saver (electronic photo album), configurable icons for home page or multi-functional pages with Micro SD card, the interruption of the power supply may cause the system's failure in starting.
- Make sure the Micro SD card only contains the firmware that needs to be used for upgrading, otherwise it may cause a system damage.
- If the device to be powered off after a setting change, it's highly recommended to cut off the power 6 seconds later after the change is done. Otherwise there is the risk of an unsuccessful change.

- ⚠ Do not power off auxiliary supply during upgrading system via Micro SD card, otherwise it may cause display error and system upgrade needs to be restarted.
- ⚠ Do not power off auxiliary supply during writing boot loader, otherwise it may cause the system's failure in starting.

Disposal



The device is considered an electronic device for disposal in accordance with the European Guidelines and may not be disposed of as domestic garbage.

- Dispose of the device through channels provided for this purpose.
- Comply with all local and currently applicable laws and regulations.

FCC

FCC Statement

This equipment has been tested and found to comply with the limits for a Class B digital device, pursuant to part 15 of the FCC Rules. These limits are designed to provide reasonable protection against harmful interference in a residential installation. This equipment generates, uses and can radiate radio frequency energy and, if not installed and used in accordance with the instructions, may cause harmful interference to radio communications. However, there is no guarantee that interference will not occur in a particular installation. If this equipment does cause harmful interference to radio or television reception, which can be determined by turning the equipment off and on, the user is encouraged to try to correct the interference by one or more of the following measures:

- Reorient or relocate the receiving antenna.
- Increase the separation between the equipment and receiver.
- Connect the equipment into an outlet on a circuit different from that to which the receiver is connected.
- Consult the dealer or an experienced radio/TV technician for help.

This device complies with Part 15 of the FCC rules. Operation is subject to the following two conditions:

1. This device may not cause harmful interference, and
2. this device must accept any interference received, including interference that may cause undesired operation

FCC Caution: Changes or modifications not expressly approved by Siemens Switzerland Ltd. could void the user's authority to operate the equipment. United States representative <https://new.siemens.com/us/en/products/buildingtechnologies/home.html>

Power supply	
Operating voltage	DC 21...30 V, powered from bus
Bus current	3.5 mA @ DC 24 V, 3.0 mA @ DC 30 V
Bus power consumption	< 90 mW
Auxiliary power voltage	DC 24...30 V
Current	< 150 mA @ DC 24 V, < 120 mA @ DC 30 V
Power consumption	< 3.6 W

Interface	
KNX	KNX bus connection terminal: black/red KNX auxiliary power supply: yellow/white Max. communication objects: 688 Max. group addresses: 2000 Max. associations: 2000

Ambient conditions and protection classification	
As per EN 62368-1 classification	
Pollution class	2
Over-voltage class	II
Safety class	Class III
Protection degree of housing as per EN 60529	IP30
Environmental conditions	
<ul style="list-style-type: none"> Storage EN 60721-3-1 	<ul style="list-style-type: none"> Class 1K3 Temperature: -25...55 °C Humidity: 0...93 % r.h. (non-condensing)
<ul style="list-style-type: none"> Transport EN 60721-3-2 	<ul style="list-style-type: none"> Class 2K3 Temperature: -25...70 °C Humidity: 0...93 % r.h. (non-condensing)
<ul style="list-style-type: none"> Operation EN 60721-3-3 	<ul style="list-style-type: none"> Class 3K5 Temperature: -5...45 °C Humidity: 0...93 % r.h. (non-condensing)
Mechanical conditions	
Storage EN 60721-3-1	Class 1M2
Transport EN 60721-3-2	Class 2M2
Operation EN 60721-3-3	Class 3M2

Standards, directives, and approvals	
Electromagnetic compatibility	For use in residential, commercial and industrial environments
EU conformity (CE)	A5W00138763A *
RCM conformity	A5W00138764A *
Environmental compatibility	The product environmental declaration (A5W00137325A *) contains data on environmentally compatible product design and assessments (RoHS compliance, materials composition, packaging, environmental benefit,

Standards, directives, and approvals	
	disposal, etc.).
General data	
Proximity sensor	Max. approximately 30 cm Note: This distance is obtained based on human detection, not an obstacle.
Built-in temperature sensor Measuring accuracy at 25 °C	NTC 100k ±1 K
Display	
5WG1205-2AB21	5 inch color capacitance touch screen, 480 × 854 pixel
Dimensions mm (w × h × d)	
5WG1205-2AB21	86 × 148.8 × 32.5
Weight without/with package	
5WG1205-2AB21	192 / 376 g
Materials and colors	
5WG1205-2AB21	<ul style="list-style-type: none"> • Rear housing: PC + V0 • Front panel: 6063 aluminum • Touch panel: Glass+Film+Film

Connection terminals

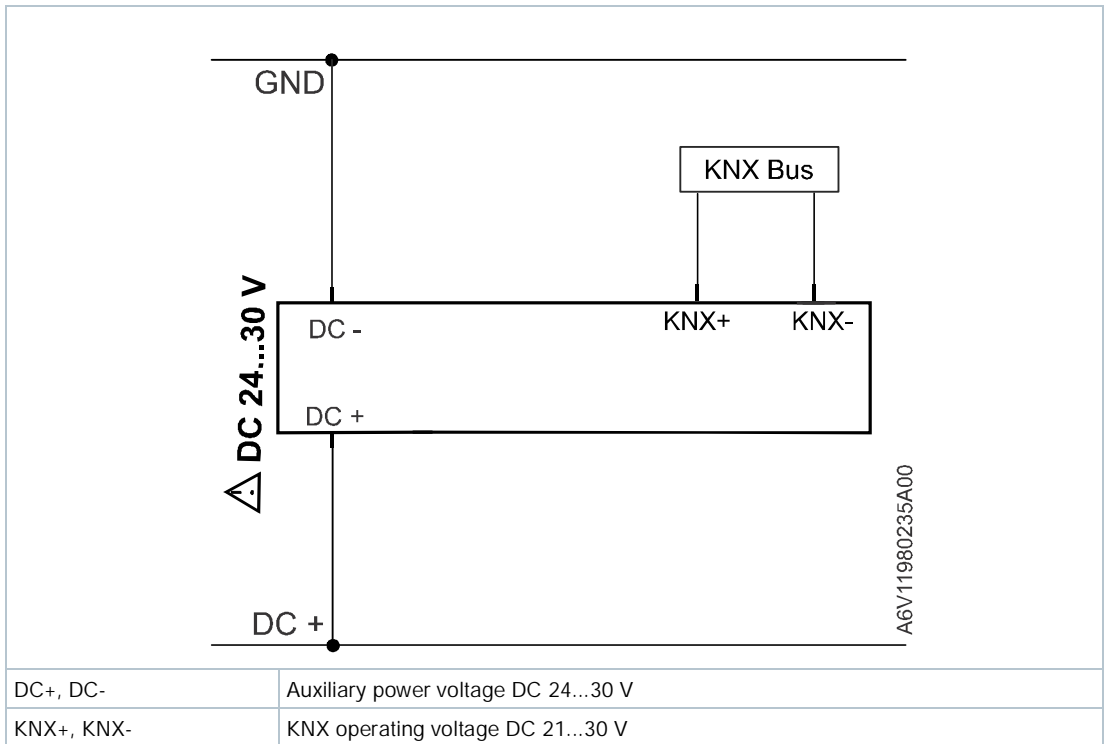

Dimensions (mm)

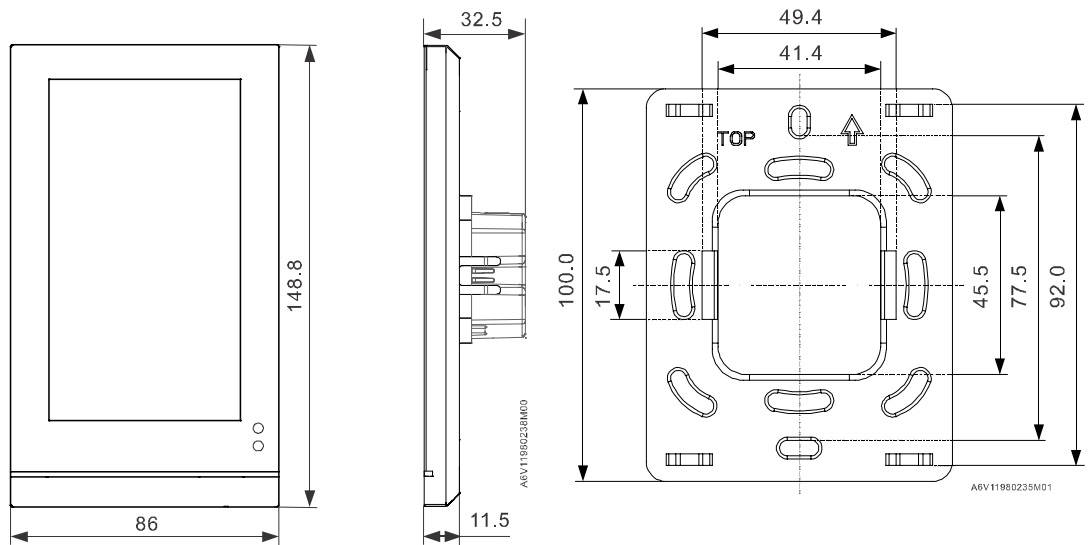

Support

- Hand over the operating instructions and all other technical product information to the client.
- Return faulty devices with a return delivery note to the local Siemens office.
- For technical questions, contact:
 - ☎ +49 (911) 895-7222
 - 📠 +49 (911) 895-7223
 - ✉ support.automation@siemens.com
 - <http://www.siemens.com/supportrequest>



Technical Support:

<http://www.siemens.com/supportrequest>



FAQ:

<http://support.industry.siemens.com/cs/ww/en/ps/faq>