

Modified differential ground fault system field testing

White Paper

Purpose

This document provides guidance for field testing, via primary current injection, for validation of proper functionality of the Siemens WL modified differential ground fault application. The configuration of this application is described in detail within the "Ground Fault Application Guide" (Siemens document number CBWP-GFWP1-1119), for providing ground fault protection when the equipment is bonded at multiple source locations. While the example includes two sources and a bus tie circuit breaker, these tests may be expanded to cover additional sources and tie circuit breakers.

Qualified person

Siemens type WL circuit breakers should only be operated, inspected, and maintained by qualified personnel. For the purpose of this guide, a qualified person is one who is familiar with the installation, construction, and operation of the equipment, and the hazards involved. In addition, he/she has the following qualifications:

- a) Is trained and authorized to energize, de-energize, clear, ground and tag circuits and equipment in accordance with established safety practices.
- b) Is trained in proper care and use of protective equipment in accordance with established safety practices.
- c) Is trained in rendering first aid.

Circuit breaker settings

The WL circuit breaker ships from the factory at the lowest possible settings. The following functional tests may be conducted at any convenient settings, although Siemens makes the following recommendations:

- a) Long-time, short-time, and instantaneous pick-up should be adjusted to maximum, or turned off.
- b) Ground fault pick-up should be adjusted down to setting "A" or the minimum pick-up point (100 A for 800 A – 3200 A circuit breakers; 300 A for 4000 A – 6000 A circuit breakers).
- c) For proper sequencing of operation, the ground fault delay of the tie circuit breaker (52-T) should be set to a value less than that of the main circuit breakers (52-1 and 52-2 in the following Figure). Recommend setting the ground fault delay to 100 ms for tie circuit breakers (52-T), and 200 ms for main circuit breakers (51-1; 52-2).

The in-service settings for all functions should be determined by a coordination study.

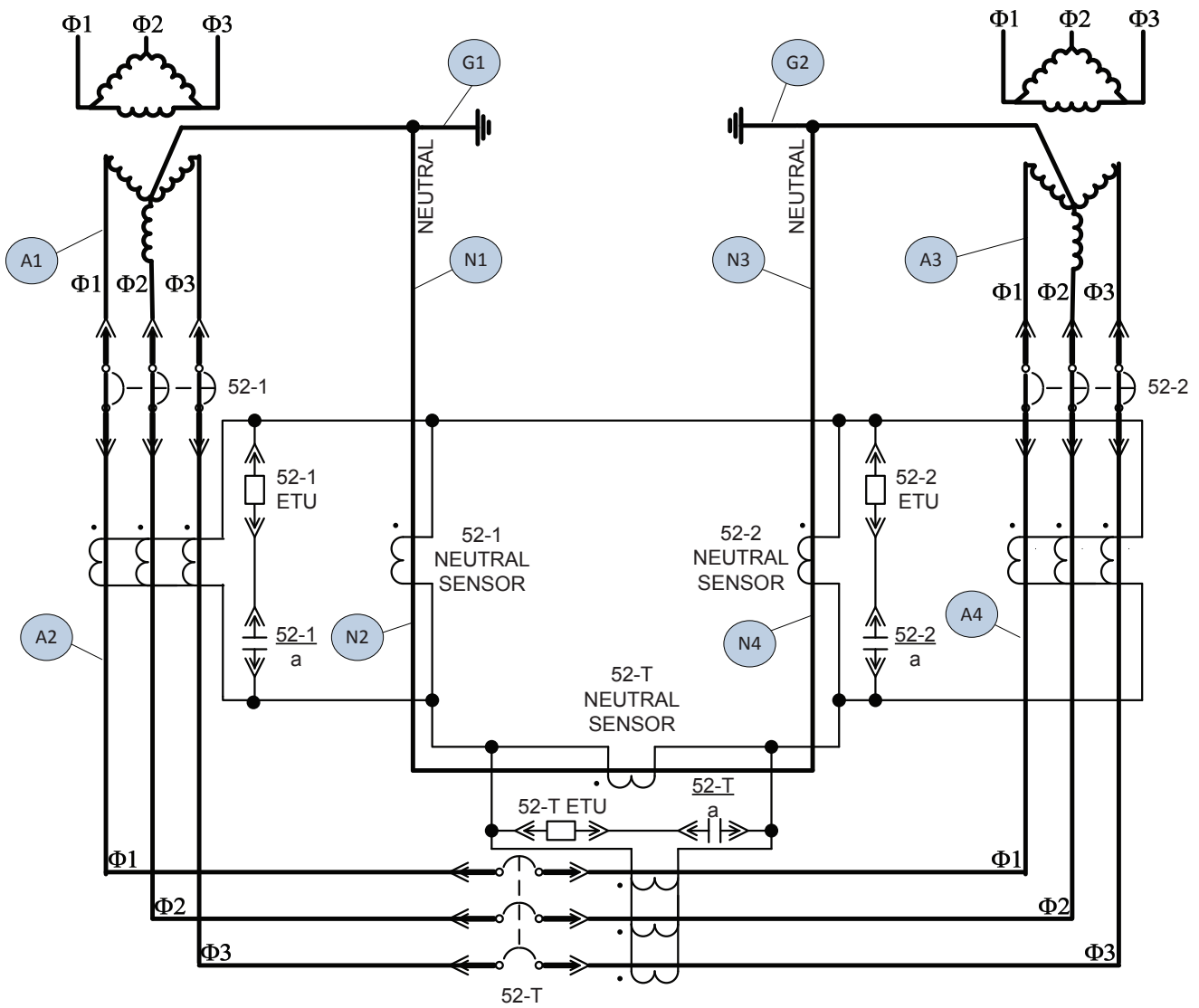

Test	Primary current source test points	Test jumper connection points	Pre-test circuit breaker state			Expected test result
			52-1	52-T	52-2	
1	A1 and N1	A2 to N2	closed	open	closed	no trip
2	A1 and N1	A2 to G1	closed	open	closed	52-1 trips on GF
3	A1 and N1	A4 to N4	closed	closed	open	no trip
4	A1 and N1	A4 to G2	closed	closed	open	52-T trips on GF; 52-1 no trip
5	A3 and N3	A4 to N4	closed	open	closed	no trip
6	A3 and N3	A4 to G2	closed	open	closed	52-2 trips on GF
7	A3 and N3	A2 to N2	open	closed	closed	no trip
8	A3 and N3	A2 to G1	open	closed	closed	52-T trips on GF; 52-2 no trip

	⚠ DANGER
	<p>Hazardous Voltage. Will cause death or serious injury.</p> <p>Qualified personnel only.</p> <p>Disconnect and lock off all power before working on this equipment.</p> <ul style="list-style-type: none"> • Always work on de-energized equipment. • Always de-energize before performing any tests, maintenance, or repair. • Follow safety related work practices, as described in NFPA 70E, at all times.

Verifying ground paths

Before testing, the ground bus of the system should be verified to determine that unintended ground paths do not exist, which could bypass the ground fault equipment discussed in this document.

This may be accomplished either by visual inspection, or with the assistance of high-voltage testers and resistance measurement test equipment.

Verifying main circuit breaker's sensor polarity (Table tests No. 1 and 5; "No-trip" test)

The following tests validate the polarity of the main circuit breaker's ground fault current sensors. Steps 1 – 5 validate Main 1, and Steps 6 – 10 validate Main 2. If there are additional main circuit breakers, repeat steps 1 – 5, with the test jumpers and test points relocated to the equivalent connection point for the additional main circuit breaker.

1. Connect the test jumper as indicated in Test 1.
2. Close both main circuit breakers (tie circuit breaker must be open, if present).
3. Inject 1000 A into phase 1 as shown in the table for 1 – 3 seconds. No circuit breaker should trip.
4. Record test results.
5. Repeat steps 1 – 4 for phases 2 and 3.
6. Connect the test jumper as indicated in Test 5.
7. Close both main circuit breakers (tie circuit breaker must be open, if present).
8. Inject 1000 A into phase 1 as shown in the table for 1 – 3 seconds. No circuit breaker should trip.
9. Record test results.
10. Repeat steps 6 – 9 for phases 2 and 3.

Verifying main circuit breaker's sensor polarity (Table tests No. 2 and 6; "Trip" test)

The following tests validate the polarity of the main circuit breaker's ground fault current sensors. Steps 1 – 5 validate Main

1, and Steps 6 – 10 validate Main 2. If there are additional main circuit breakers, repeat steps 1 – 5, with the test jumpers and test points relocated to the equivalent connection point for the additional main circuit breaker.

1. Connect the test jumper as indicated in Test 2.
2. Close both main circuit breakers (tie circuit breaker must be open, if present).
3. Inject 1000 A into phase 1 as shown in the table for 1 – 3 seconds. The main circuit breaker (52-1) should trip.
4. Record test results.
5. Repeat steps 1 – 4 for phases 2 and 3.
6. Connect the test jumper as indicated in Test 6.
7. Close both main circuit breakers (tie circuit breaker must be open, if present).
8. Inject 1000 A into phase 1 as shown in the table for 1 – 3 seconds. The main circuit breaker (52-2) should trip.
9. Record test results.
10. Repeat steps 6 – 9 for phases 2 and 3.

The following tests are required when tie circuit breakers are applied between alternate power sources. If the application does not utilize tie circuit breakers, or the tie circuit breaker does not have integral protection, the following tests may be omitted.

Verifying tie circuit breaker's sensor polarity (Table tests No. 3 and 7; "No-trip" test)

The following tests validate the polarity of the tie circuit breaker's ground fault current sensors. Steps 1 – 5 validate Main 1, and Steps 6 – 10 validate Main 2. If there are additional main circuit breakers isolated by a tie circuit breaker from the rest of the power system, repeat steps 1 – 5, with the test jumpers and test points relocated to the equivalent connection point for the additional main circuit breaker and tie circuit breaker.

1. Connect the test jumper as indicated in Test 3.
2. Close main circuit breaker (52-1) and the tie circuit breaker (52-T). Main 2 circuit breaker must be open.
3. Inject 1000 A into phase 1 as shown in the table for 1 – 3 seconds. No circuit breaker should trip.
4. Record test results.
5. Repeat steps 1 – 4 for phases 2 and 3.
6. Connect the test jumper as indicated in Test 7.
7. Close the alternate main circuit breaker (52-2) and the tie circuit breaker (52-T). Main 1 circuit breaker (52-1) must be open.
8. Inject 1000 A into phase 1 as shown in the table for 1 – 3 seconds. No circuit breaker should trip.
9. Record test results.
10. Repeat steps 6 – 9 for phases 2 and 3.

Verifying tie circuit breaker's sensor polarity (Table tests No. 4 and 8; "trip" test)

The following tests validate the polarity of the main circuit breaker's ground fault current sensors. Steps 1 – 5 validate Main 1, and Steps 6 – 10 validate Main 2. If there are additional main circuit breakers isolated by a tie circuit breaker from the rest of the power system, repeat steps 1 – 5, with the test jumpers and test points relocated to the equivalent connection point for the additional main circuit breaker and tie circuit breaker.

1. Connect the test jumper as indicated in Test 4.
2. Close main circuit breaker (52-1) and the tie circuit breaker (52-T). Main 2 circuit breaker (52-2) must be open.
3. Inject 1000 A into phase 1 as shown in the table for 1 – 3 seconds. The tie circuit breaker (52-T) should trip.
4. Record test results.
5. Repeat steps 1 – 4 for phases 2 and 3.
6. Connect the test jumper as indicated in Test 8.
7. Close the alternate main circuit breaker (52-2) and the tie circuit breaker (52-T). Main 1 circuit breaker must be open.
8. Inject 1000 A into phase 1 as shown in the table for 1 – 3 seconds. The tie circuit breaker (52-T) should trip.
9. Record test results.
10. Repeat steps 6 – 9 for phases 2 and 3.

Sample Test Report

As previously discussed, the test results should be recorded and retained for future use. See page 5 for a sample test report.

Technical Support

For technical support, please contact the Technical Support Hotline at 1- 800-333-7421, or submit a request through Online Support Request: <http://support.automation.siemens.com/US>

SIEMENS**Modified Differential Ground Fault System Field Testing Report**

Date: _____

Tested By: _____ Employed By: _____

Note: This test report should be retained by those in charge of the building's electrical installation in order to be available to the authority having jurisdiction.

Identification No (52-1): _____

Identification No (52-T): _____

Identification No (52-2): _____

Identification No (___): _____

Identification No (___): _____

Ground Path InspectionVerified that there are no ground paths bypassing the ground fault sensors. **Test Results**

Test	Expected Result	Line 1	Line 2	Line 3
1	no trip			
2	trip (0 - 0.5 sec)			
3	no trip			
4	trip (0 - 0.5 sec)			
5	no trip			
6	trip (0 - 0.5 sec)			
7	no trip			
8	trip (0 - 0.5 sec)			

Notes

**Published by
Siemens 2019**

Siemens Industry, Inc.
5400 Triangle Parkway
Norcross, GA 30092

Siemens Technical Support: 1-800-333-7421
info.us@siemens.com

Order No.CBWP-MDGFT-1119

Printed in USA-CP
All Rights Reserved
© 2019, Siemens Industry, Inc.
usa.siemens.com/powerdistribution

The technical data presented in this document is based on an actual case or on as-designed parameters, and therefore should not be relied upon for any specific application and does not constitute a performance guarantee for any projects. Actual results are dependent on variable conditions. Accordingly, Siemens does not make representations, warranties, or assurances as to the accuracy, currency or completeness of the content contained herein. If requested, we will provide specific technical data or specifications with respect to any customer's particular applications. Our company is constantly involved in engineering and development. For that reason, we reserve the right to modify, at any time, the technology and product specifications contained herein.