



## **INSTRUCTION & INSTALLATION**

# **SOLID-STATE CROSSING CONTROLLER III PLUS (SSCC III PLUS) A91190 & A91195**

SEPTEMBER 2007, REVISED APRIL 2014

DOCUMENT NO. SIG-00-02-03  
VERSION F.1

Siemens Rail Automation Corporation  
9568 Archibald Ave., Suite 100,  
Rancho Cucamonga, California 91730  
1-800-793-SAFE

Copyright © 2014 Siemens Rail Automation Corporation  
All rights reserved

## PROPRIETARY INFORMATION

Siemens Rail Automation Corporation has a proprietary interest in the information contained herein and, in some instances, has patent rights in the systems and components described. It is requested that you distribute this information only to those responsible people within your organization who have an official interest.

This document, or the information disclosed herein, shall not be reproduced or transferred to other documents or used or disclosed for manufacturing or for any other purpose except as specifically authorized in writing by **Siemens Rail Automation Corporation**.

## TRANSLATIONS

The manuals and product information of Siemens Rail Automation Corporation are intended to be produced and read in English. Any translation of the manuals and product information are unofficial and can be imprecise and inaccurate in whole or in part. Siemens Rail Automation Corporation does not warrant the accuracy, reliability, or timeliness of any information contained in any translation of manual or product information from its original official released version in English and shall not be liable for any losses caused by such reliance on the accuracy, reliability, or timeliness of such information. Any person or entity who relies on translated information does so at his or her own risk.

## WARRANTY INFORMATION

Siemens Rail Automation Corporation warranty policy is as stated in the current Terms and Conditions of Sale document. Warranty adjustments will not be allowed for products or components which have been subjected to abuse, alteration, improper handling or installation, or which have not been operated in accordance with Seller's instructions. Alteration or removal of any serial number or identification mark voids the warranty.

## SALES AND SERVICE LOCATIONS

Technical assistance and sales information on **Siemens Rail Automation Corporation** products may be obtained at the following locations:

Siemens Rail Automation Corporation  
2400 NELSON MILLER PARKWAY  
LOUISVILLE, KENTUCKY 40223  
TELEPHONE: (502) 618-8800  
FAX: (502) 618-8810  
SALES & SERVICE: (800) 626-2710  
WEB SITE: <http://www.rail-automation.com/>

Siemens Rail Automation Corporation  
939 S. MAIN STREET  
MARION, KENTUCKY 42064  
TELEPHONE: (270) 918-7800  
CUSTOMER SERVICE: (800) 626-2710  
TECHNICAL SUPPORT: (800) 793-7233  
FAX: (270) 918-7830

## FCC RULES COMPLIANCE

The equipment covered in this manual has been tested and found to comply with the limits for a Class A digital device, pursuant to part 15 of the FCC Rules. These limits are designed to provide reasonable protection against harmful interference when the equipment is operated in a commercial environment. This equipment generates, uses, and can radiate radio frequency energy and, if not installed and used in accordance with the instruction manual, may cause harmful interference to radio communications. Operation of this equipment in a residential area is likely to cause harmful interference in which case the user will be required to correct the interference at his/her own expense.

## DOCUMENT HISTORY

Version	Release Date	Details of Change(s)
1.0	03-08-2002	Preliminary review copy.
2.0	04-17-2002	2 <sup>nd</sup> Preliminary review copy.
3.0	05-16-2002	3 <sup>rd</sup> Preliminary review copy.
3.1	05-17-02	Minor corrections to 3 <sup>rd</sup> preliminary
3.2	08-01-02	Revised 3 <sup>rd</sup> preliminary to include new Section VII – software loading via GDT.
4.0	08-06-02	4 <sup>th</sup> Preliminary review copy – added warnings.
A	10-25-02	Initial Release
B	12-17-02	Revised MCF release data sheet, revised glossary, corrected errors in sections I and II, corrected logic diagrams in section III, corrected errors in sections IV through VII, added example data log to section VIII, corrected figures 10-1 and 10-2, added figure 10-3, revised History Card.
B1	02-17-03	<p>Revised MCF Release History versions and CRCs. Revised Glossary to add “Acronym for” to ATCS, FPM, GDT Utility, Liquid Crystal Display, Loss-Of-Shunt. Revised Section I, paragraph 1.1.1.1 to add “Enhanced” to Crossing and lamp test modes bullet and add bullet for “Echelon<sup>®</sup> connectivity to other Safetran products, such as the SEAR II event analyzer”. Changed SEA/R to SEAR II, and 80250 to 80273 in paragraph 1.2.2.2, added “via non-vital messages” to the first sentence, and changed the note to indicate “part number 80250”. Revised paragraph 1.3.1.5, Internal Event Recorder: to change word “disconnected” to “lost”. Revised the warnings in paragraphs 1.3.1.7, 2.1.2.1, 2.1.2.2, 2.1.4, 2.2, 2.2.1, 4.1.1.5, and 4.1.1.11. Revised table 2-2 to include 12.5 Amp column. Revised paragraph 2.1.2.6 to agree with table 2-2. Revised figure 2-8 to show version C in display. Revised Section IV, paragraph 4.1.1.7 and figure 4-2 to change Advanced Pre-emption Time range from 1-30 seconds to 1-60 seconds. Changed the note about “If input power is lost...” in paragraph 4.1.7 to a warning. Revised Section V, paragraph 5.1.2, steps 5 through 9 to incorporate entering the MCF ID number. Added a note on resetting the MAINT CALL by activating the crossing to the very end of Section V. Changed “compensated batteries” to “compensated battery chargers” in paragraph 6.1. Revised paragraph 6.5 to change “the neutral wire” to “all neutral wires”, changed step 4 “OPEN NEUTRAL” to “LAMP NEUTRAL WIRE OPEN”, and reworded the last sentence. Revised the check list in paragraph 6.6.1 for #15 and #16. Revised paragraph 8.2 and figure 8-4 to reflect SEAR II instead of SEA/R, and added “part number 80250 to the note. Revised figures 10-1, 10-2, and 10-3 to add equalizer and two arresters. Revised History Card Sheet 1 of 2 to change the PROGRAM parameter ADV PRE-EMPT TIME (40A), Notes column from “1 – 30 sec.” to “1 – 60 sec.”.</p> <p>Revised manual per results of Inspection number CR-F75.</p> <p>Released version C of manual after incorporating changes per Inspection</p>

Version	Release Date	Details of Change(s)
B2	07-07-03	number CR-F75.
C	07-21-03	<p>18. Changes (identified with Change Bars in following sections) include: Changed units available listing in subsection 1.0. Eliminated 'common return gate control' feature in subsection 1.1.1.1. Figures 1-1 and 1-2 change to reflect available units. In subsection 1.1.2, unit numbers in the bulleted list have changed. Also in 1.1.2, order of figures and references to figures changes. Change in unit designation reflected. Also in 1.1.2, changes in figures 1-7 and 1-8 and a new warning is added: "DO NOT JUMPER 1 GC (-) OR 1 GC (+) DIRECTLY TO N ON CONNECTOR J2." In table 1-2, changes in available units. In subsection 1.2.4 a new subsection is added: "REMOVING INPUT POWER FROM THE SSCC III PLUS UNIT WILL CAUSE THE GATE(S) TO DROP BUT THE LAMPS AND BELLS WILL NOT BE ACTIVATED." In subsection 1.2.5, added one sentence paragraph at end of subsection: "The 'Open Lamp Neutral Wire' detection test may be disabled from the CONFIGURE Menu." New subsection 1.2.8. In subsection 1.3.1.8 added new warning: "INCORRECT POLARITY WILL RESULT IN SEVERE DAMAGE TO THE CONTROLLER UNIT" and changed definition of Vital Control Inputs. In subsection 1.4, ordering information changes to reflect available units. In subsection 1.4.3 table changes to reflect changes in available units. On page 2-1, references to figures in Section 10 change to reflect additional changes. Figures 2-1 and 2-2 change to reflect changes in Front Panel art. In subsection 2.1.2, added sentence at end of paragraph: "Safetran does not provide the wiring harness." Changed note at end of subsection 2.1.2 to refer to "8+ (GP+) input" and "8- (GP - ) input" to reflect change in front panel labeling. In subsection 2.1.2.2, added two additional warnings. In 2.1.2.6, added sentence at end of first paragraph: "This condition will trigger errors of "Open Lamp Neutral Wire" detection." Minor change in Figure 2-5: "SSCC II PLUS" changes to "SSCC" to generalize the illustration. In subsection 2.1.3, the second paragraph reflects changes in available units. In subsection 2.1.4, two new warnings and a final paragraph are added. In subsection 2.2 additional warning and small change in another warning. Updates in figures 2-9 and 2-11. In subsection 2.2.1, small change in final warning paragraph. In section 3.0 added to end of first paragraph: "The 2GC output on the 40-amp unit can be used to control a normal gate control relay, an inverted gate control for exit gate mechanisms, or drive a relay for traffic signal pre-emption." Added one sentence paragraph after note at the start of 3.1: "Each MCF has a unique MCF ID number that must be entered after the MCF is loaded or changed." Numbering in table captions and references thereto is corrected. In second para. Of 3.0, "and Configure menus..." In subsection 3.1.5.2, figure 3-6 changes to reflect changes in MCF. In 3.1.5.4, the title changes and the following sentence is added: "The ATESR Latch prevents an intermittent island circuit from resetting the Stick Cancellation Timer." In subsection 3.9.4, Figure 3-10 changes to show the XRP contact in the 2GC equation. Section 4.1.2.6 is new (Configure Detect Lamp Neutral Wire). In Figure 4-20 a note is now associated with the 'PRG STK RELEASE.' In Figure 4-28 the note associated with the 'PRG ENABLED' screen changes. In subsection 4.1.3.3, new note at end of subsection. In subsection 5.1.1.2, a new note is added after step 4. Also in subsection 5.1.1.2, a phrase is</p>
D	04-13-04	

Version	Release Date	Details of Change(s)
E	10-06-05	<p>added to step (23): "if the Stick Cancellation Timer is not running". At the end of 5.1.1.3, steps (17) and (18) are new while (19) was (17). Figure 6-1 changes to be generic, that is, "SSCC III PLUS" changes to "SSCC". New warning and note in 7.0. Added section 7.2 (from SSCC IIIA I &amp; I manual). In section 8.1, added trademark to Echelon; updated figure 8-1 to show to front panel; and added note. Figures 8-2 and 8-3 change to show new front panel. In subsection 8.2.2, removed underline from "all" in "all events". In subsection 9.2, added reference to Appendix B. In section 10, figure 10-1 to 10-9 are new. Appendix B reflects MCF updates.</p> <p>Paragraph numbering style changes throughout.</p> <p>Page 1-2 , paragraph 1.2.1.1 Added features as indicated in bold below:</p> <ul style="list-style-type: none"> <li>• Programmable gate control delay (40-Ampere unit includes second GC, inverted GC, pre-emption relay drive, or <b>advance warning sign beacon relay drive</b>)</li> <li>• Configurable <b>application and</b> test timers</li> </ul> <p>Page 1-11, Table 1-2 for connector J2, pin 7 Added text in bold below: <b>This output is referenced to negative battery.</b></p> <p>Page 1-12, paragraph 1.3.2.1 Removed reference to running DT software on Pocket PC (not currently supported).</p> <p>Page 1-13, paragraph 1.3.2.1 Added WARNING following first paragraph at top of page.</p> <p>Page 1-19, paragraph 1.4.1.5 Downgraded WARNING to CAUTION.</p> <p>Page 1-21, paragraph 1.4.1.8 Added following bullet to Non-vital I/O 1 – (Flash Sync) specification:</p> <ul style="list-style-type: none"> <li>• This I/O is referenced to controller's negative battery</li> </ul> <p>Page 1-25,</p> <ul style="list-style-type: none"> <li>• Added paragraphs 1.5.3 and 1.5.4</li> </ul> <p>Page 2-11, <b>2.2.4 SSCC III PLUS DC Power Connections</b></p> <ul style="list-style-type: none"> <li>• Changed WARNING to the following CAUTION</li> </ul> <p style="text-align: center;"><b><u>CAUTION</u></b></p> <p style="text-align: center;">DO NOT CONNECT POWER TO THE SSCC UNTIL AFTER COMPLYING WITH PARAGRAPH 2.3. FAILURE TO INITIALLY "POWER UP" IN THE PROPER SEQUENCE MAY PREVENT SHORT-CIRCUIT PROTECTION FROM DETECTING WIRING ERRORS AND DAMAGE THE UNIT</p> <p>Page 2-12, 2-13</p> <ul style="list-style-type: none"> <li>• Made WARNING from last sentence of last paragraph in 2.2.4.</li> </ul>

Version	Release Date	Details of Change(s)
		<ul style="list-style-type: none"> <li>• Inserted paragraph 2.2.5 (<b>Non-Vital I/O 1 (Flash Sync) Connection</b>), figure 2-7 and associated notes.</li> </ul> <p>Page 2-13, 2-14</p> <ul style="list-style-type: none"> <li>• Inserted paragraph 2.2.6 (<b>Traffic Signal Preempt Relay Connections</b>) and figure 2-8.</li> </ul> <p>Page 2-16, <b>2.2.7.1 Rules For Using Echelon® LAN</b></p> <ul style="list-style-type: none"> <li>• Downgraded WARNING to CAUTION.</li> </ul> <p>Page 2-16, 2-17, <b>2.3 POWER UP AND INITIALIZATION</b></p> <ul style="list-style-type: none"> <li>• Removed two WARNINGS and a CAUTION, inserted the following WARNING:</li> </ul> <p style="text-align: center;"><b><u>WARNING</u></b></p> <p><b>OBSERVE CORRECT POLARITY WHEN CONNECTING BATTERY TO THE SSCC IV B AND N CONTACTS ON FRONT-PANEL CONNECTOR J2. REVERSED POLARITY WILL RESULT IN CONTROLLER DAMAGE</b></p> <ul style="list-style-type: none"> <li>• Revised first sentence and added five steps for a startup procedure.</li> <li>• Added text to end of final NOTE (“The warning devices will remain activated until the proper inputs are energized for MCF selected”)</li> </ul> <p>Page 2-18, <b>2.3.1 Failure During Power Up and Initialization</b></p> <ul style="list-style-type: none"> <li>• Added “<b>PEDESTRIANS,</b>” to second paragraph of WARNING.</li> </ul> <p>Page 3-1, <b>3.1 GENERAL</b></p> <ul style="list-style-type: none"> <li>• Added to second paragraph: “. . . GCP and DAX inputs, PSO track circuits, wrap circuits, or traffic signal pre-emption relay check contact. An LED indicator is associated with each input. When the input is activated the LED is illuminated, and when the input is deactivated the LED is dark. The Two Track Directional Stick MCF (2TRKDSTK) uses a flashing LED to indicate that the directional stick is bypassing an input in the XR circuit.”</li> <li>• Added to second paragraph: “. . . or active beacon on highway-railroad advance warning signs.”</li> </ul> <p>Page 3-2, Table 3-1</p> <ul style="list-style-type: none"> <li>• Following text added to all MCF descriptions except BASIC and DAXPRMT MCFs: “In addition, this MCF supports active beacons on highway-railroad advance warning signs.”</li> <li>• Added to 2TRKDSTK MCF: “In addition, this MCF supports active beacons on highway-railroad advance warning signs, and an optional test switch input for activating warning devices and releasing the directional stick.”</li> </ul>

Version	Release Date	Details of Change(s)
		<p>Page 3-3</p> <ul style="list-style-type: none"> <li>Added following NOTE: <ul style="list-style-type: none"> <li><b>NOTE</b></li> </ul> </li> </ul> <p>Active Beacons are one or more flashing yellow signal heads on a Highway-Railroad Advance Warning Sign mast that are used to provide supplemental emphasis to the advance warning sign while the highway-railroad grade crossing warning devices are activated. Active beacons may be installed by the highway agency when curves or hills restrict preview of a highway-railroad grade warning system. A BEACON DELAY TIMER may be used to keep the beacon activated a period of time after the warning devices deactivate. The purpose of the delay time is to provide time for traffic stopped at the crossing to resume speed before the active beacon is turned off. The delay time is determined by engineering study.</p> <p>Page 3-6, <b>3.2.2.1 BASICPLS MCF Description</b></p> <ul style="list-style-type: none"> <li>Added the following text; “. . . or Beacon, where 2GC controls an active beacon on a highway-railroad advance warning sign. Input #7 is a configurable input that can be used for crossing activation, or for traffic pre-emption relay health check. Refer to paragraph 3.3 for using 2GC Output / Input #7 (2GC/I7).”</li> </ul> <p>Page 3-6, <b>3.2.2.2 BASICPLS MCF Operation</b></p> <ul style="list-style-type: none"> <li>Last sentence, changed input 7 to input 4.</li> </ul> <p>Page 3-8, <b>3.2.3.1 3TRK1WRP MCF Description</b></p> <ul style="list-style-type: none"> <li>Added the following text; “. . . or Beacon, where 2GC controls an active beacon on a highway-railroad advance warning sign. Input #7 is a configurable input that can be used for crossing activation, or for traffic pre-emption relay health check. Refer to paragraph 3.3 for using 2GC Output / Input #7 (2GC/I7).”</li> </ul> <p>Page 3-9, <b>3.2.3.3 3TRK1WRP MCF Physical Inputs</b></p> <ul style="list-style-type: none"> <li>Added following Note for inputs 3 and 5 in Table 3-4: “Disable in Program menu if not used”</li> </ul> <p>Page 3-10, <b>3.2.4.1 2TRK2WRP MCF Description</b></p> <ul style="list-style-type: none"> <li>Added the following text; “. . . or Beacon, where 2GC controls an active beacon on a highway-railroad advance warning sign. Input #7 is a configurable input that can be used for crossing activation, or for traffic pre-emption relay health check. Refer to paragraph 3.3 for using 2GC Output / Input #7 (2GC/I7).”</li> </ul> <p>Page 3-11, <b>3.2.4.3 2TRK2WRP MCF Physical Inputs</b></p> <ul style="list-style-type: none"> <li>Added following Note for input 5 in Table 3-5: “Disable in Program menu if not used”</li> </ul> <p>Page 3-12, <b>3.2.5.1 2TRKDSTK MCF Description</b></p> <ul style="list-style-type: none"> <li>Added the following text; “. . . or Beacon, where 2GC controls an active beacon on a highway-railroad advance warning sign. Input #7 is a configurable input that can be used for crossing activation, or for traffic pre-emption relay health check. Refer to paragraph 3.3 for using</li> </ul>

Version	Release Date	Details of Change(s)
		<p>2GC Output / Input #7 (2GC/I7).”</p> <p>Page 3-14, <b>3.2.5.3 2TRKDSTK MCF Physical Inputs</b></p> <ul style="list-style-type: none"> <li>• Added following Note for input 5 in Table 3-6: “Disable in Program menu if not used”</li> <li>• Modified text and added note as follows: “Inputs for a 2TRKDSTK MCF may be from any discrete track circuit, or combination of track circuits, representing each approach circuit and island circuit, such as audio track circuits, DC or AC track circuits, or Style C track circuits. The corresponding input LED flashes when the directional stick is ‘picked’ to bypass that input.”</li> </ul> <p style="text-align: center;"><b>NOTE</b></p> <p>While a flashing input LED indicates that the directional stick is “picked” bypassing that input, it does not indicate that the input is deenergized. When the input LED is flashing and the entering approach and island input LEDs are lit, the directional stick is “stuck” indicating the input is deenergized.</p> <p>Page 3-15</p> <ul style="list-style-type: none"> <li>• Added “<b>3.2.5.6 Test Switch Mode</b>” text plus WARNING, CAUTION and NOTE.</li> </ul> <p>Page 3-16, <b>3.2.6.1 SUPISL MCF Description</b></p> <ul style="list-style-type: none"> <li>• Strike “(such as a wheel counter system)” from second sentence.</li> <li>• Added the following text; “, . . . or Beacon, where 2GC controls an active beacon on a highway-railroad advance warning sign. Input #7 is a configurable input that can be used for crossing activation, or for traffic pre-emption relay health check. Refer to paragraph 3.3 for using 2GC Output / Input #7 (2GC/I7).”</li> </ul> <p>Page 3-17, <b>3.2.6.3 SUPISL MCF Physical Inputs</b></p> <ul style="list-style-type: none"> <li>• Added following Note for input 5 in Table 3-7: “Disable in Program menu if not used”</li> </ul> <p>Page 3-17</p> <ul style="list-style-type: none"> <li>• Added “<b>3.2.6.5 Supplemental Island Timer</b>” text.</li> </ul> <p>Page 3-18, <b>3.2.7.1 3TRK2TRN MCF Description</b></p> <ul style="list-style-type: none"> <li>• Added the following text; “, . . . or Beacon, where 2GC controls an active beacon on a highway-railroad advance warning sign. Input #7 is a configurable input that can be used for crossing activation, or for traffic pre-emption relay health check. Refer to paragraph 3.3 for using 2GC Output / Input #7 (2GC/I7).”</li> </ul> <p>Page 3-19, <b>3.2.7.3 3TRK2TRN MCF Physical Inputs</b></p> <ul style="list-style-type: none"> <li>• Added following Note for inputs 3 and 5 in Table 3-8: “Disable in Program menu if not used”</li> </ul> <p>Page 3-20, <b>3.2.8.1 2TRK2TRN MCF Description</b></p> <ul style="list-style-type: none"> <li>• Added the following text; “, . . . or Beacon, where 2GC controls an active beacon on a highway-railroad advance warning sign. Input #7 is a configurable input that can be used for crossing activation, or for</li> </ul>



Version	Release Date	Details of Change(s)
		<p>traffic pre-emption relay health check. Refer to paragraph 3.3 for using 2GC Output / Input #7 (2GC/I7)."</p> <p>Page 3-21, <b>3.2.8.3 2TRK2TRN MCF Physical Inputs</b></p> <ul style="list-style-type: none"> <li>Added following Note for input 5 in Table 3-9: "Disable in Program menu if not used".</li> </ul> <p>Page 3-22, <b>3.2.9.1 DAXPRMT MCF Description</b></p> <ul style="list-style-type: none"> <li>Added the following note:</li> </ul> <p style="text-align: center;"><b><u>NOTE</u></b></p> <p>If LOS timer functionality is required, it should be a function of the train detection equipment providing input to the crossing controller.</p> <p>Page 3-22, <b>3.2.9.2 DAXPRMT MCF Operation</b></p> <ul style="list-style-type: none"> <li>Added the following note:</li> </ul> <p style="text-align: center;"><b><u>NOTE</u></b></p> <p>Effective with version 'F' of this MCF, the Advance Pre-empt Timer must complete before the Minimum Activation Timer begins. This results in forcing the complete cycling of Advance Pre-empt and Minimum Activation times, even in the event of a false train detection.</p> <p>Page 3-24, <b>3.2.9.3 DAXPRMT MCF Physical Inputs</b></p> <ul style="list-style-type: none"> <li>Added following Note for inputs 3 and 5 in Table 3-10: "Disable in Program menu if not used".</li> </ul> <p>Page 3-24, <b>3.3 USING 2GC OUTPUT / INPUT #7 MODE (2GC/I7)</b></p> <ul style="list-style-type: none"> <li>Added to second sentence of note: ". . . or Beacon, where 2GC controls an active beacon on a highway-railroad advance warning sign."</li> </ul> <p>Pages 3-25 through 3-27</p> <ul style="list-style-type: none"> <li>Added paragraphs 3.3.1 through 3.3.6.</li> </ul> <p><b>Page 4-4, 4.2.1.3 Program Gate Delay Timers</b></p> <ul style="list-style-type: none"> <li>Reword first note.</li> </ul> <p>Page 4-5, <b>Table 4-1. SSCC IV Displays for Enabling Inputs (by MCF)</b></p> <ul style="list-style-type: none"> <li>Input number changes in third and fourth columns.</li> </ul> <p>Page 4-5</p> <ul style="list-style-type: none"> <li>Added note at bottom of page.</li> </ul> <p>Page 4-6, <b>4.2.1.6 Program 2GC/I7 MODE (40-Amp Unit Only)</b></p> <ul style="list-style-type: none"> <li>Added "and BEACON" to end of second sentence in second paragraph.</li> </ul> <p>Page 4-6, Table 4-2</p> <ul style="list-style-type: none"> <li>Added Beacon information.</li> </ul> <p>Page 4-6</p> <ul style="list-style-type: none"> <li>Added WARNING at bottom of page.</li> </ul>

Version	Release Date	Details of Change(s)
		<ul style="list-style-type: none"> <li>• Added “and Beacon” to second sentence of note below new WARNING.</li> </ul> <p>Page 4-7, <b>4.2.1.7 Program Advance Pre-emption Time (40-Amp Unit Only)</b></p> <ul style="list-style-type: none"> <li>• First paragraph following note, changed range high limit to 99 seconds.</li> </ul> <p>Page 4-8, <b>4.2.1.8 Program Minimum Activation Time</b></p> <ul style="list-style-type: none"> <li>• Added note.</li> <li>• First paragraph following note, changed range high limit to 99 seconds.</li> </ul> <p>Page 4-8, 4-9</p> <ul style="list-style-type: none"> <li>• Inserted the following new material:  <b>4.2.1.9 Program Beacon Delay Time</b>  <b>4.2.1.10 Program Island Delay Enable</b></li> </ul> <p><b>Page 4-9, 4.2.1.11 Program Stick Release Time (2TRKDSTK MCF Only)</b></p> <ul style="list-style-type: none"> <li>• First paragraph, first sentence, added “for each track”.</li> <li>• First paragraph, second sentence, changed range high limit to 120 minutes.</li> <li>• Added WARNING.</li> </ul> <p>Page 4-10</p> <p><b>Inserted “4.2.1.13 Program Input 7 (40-Amp Unit Only)(2TRKDSTK MCF only)”</b></p> <p><b>Inserted “4.2.1.14 Program Test Switch (2TRKDSTK MCF only)”</b></p> <p>Page 4-19, <b>4.2.2.5 Configure Aux. I/O</b></p> <ul style="list-style-type: none"> <li>• Added paragraph below figure 4-2.</li> </ul> <p>Page 5-5, <b>Table 5-1</b></p> <ul style="list-style-type: none"> <li>• Added “In addition, this MCF supports active beacons on highway-railroad advance warning signs.” To various MCF descriptions</li> </ul> <p>Page 5-5</p> <ul style="list-style-type: none"> <li>• Added note to step 14, added “or Beacon” to step 15.</li> <li>• Insert new steps 19-20.</li> </ul> <p>Page 5-5</p> <ul style="list-style-type: none"> <li>• Insert new steps 27-30.</li> </ul> <p>Page 5-10</p> <ul style="list-style-type: none"> <li>• Inserted WARNING at top of page before step 32.</li> </ul> <p>Page 5-17, <b>5.2.2 Using the SERVICE Menu</b></p> <ul style="list-style-type: none"> <li>• Modified paragraph to “Using the Out of Service Menu” and added explanatory text.</li> </ul> <p>Page 6-10, <b>6.6.1 SSCC IV Crossing Operational Check List &amp; Tests</b></p>

Version	Release Date	Details of Change(s)
E.1	02-07-06	<ul style="list-style-type: none"> <li>• Added/modified Check / Test steps.</li> </ul> <p>Page 7-2, Figure 7-1</p> <ul style="list-style-type: none"> <li>• Added note to flow diagram.</li> </ul> <p>Page 8-1, <b>8.2 LAN</b></p> <ul style="list-style-type: none"> <li>• Added information on ATCS addressing.</li> </ul> <p>Page 9-1, <b>9.1 SOFTWARE UPGRADE</b></p> <ul style="list-style-type: none"> <li>• Added WARNING</li> </ul> <p>Page B-2, Appendix B</p> <ul style="list-style-type: none"> <li>• Minor wording change to WARNING.</li> </ul> <p>Appendix B: Update of MCF info.</p> <p>Changed footers to reflect 'Rev E1' changes</p> <p>Page 4-19, paragraph 4.2.2.6</p> <ul style="list-style-type: none"> <li>• Added note below paragraph title "...Disable DETECT LAMP NEUTRAL WIRE..."</li> </ul> <p>Page 4-37, Figure 4-11</p> <ul style="list-style-type: none"> <li>• Added note next to Default YES..., "...Set to NO..."</li> </ul> <p>Page 4-39, Figure 4-13</p> <ul style="list-style-type: none"> <li>• Added note next to Default = YES, "...Set to NO..."</li> </ul> <p>Page 4-41, Figure 4-15</p> <ul style="list-style-type: none"> <li>• Added note next to Default = YES, "...Set to NO..."</li> </ul> <p>Page 4-43, Figure 4-17</p> <ul style="list-style-type: none"> <li>• Added note next to Default = YES, "...Set to NO..."</li> </ul> <p>Page 4-45, Figure 4-19</p> <ul style="list-style-type: none"> <li>• Added note next to Default = YES, "...Set to NO..."</li> </ul> <p>Page 4-47, Figure 4-21</p> <ul style="list-style-type: none"> <li>• Added note next to Default = YES, "...Set to NO..."</li> </ul> <p>Page 4-49, Figure 4-23</p> <ul style="list-style-type: none"> <li>• Added note next to Default = YES, "...Set to NO..."</li> </ul> <p>Page 4-51, Figure 4-25</p> <ul style="list-style-type: none"> <li>• Added note next to Default = YES, "...Set to NO..."</li> </ul> <p>Page 4-53, Figure 4-27</p> <ul style="list-style-type: none"> <li>• Added note next to Default = YES, "...Set to NO..."</li> </ul> <p>Page 6-2, paragraph 6.3</p> <ul style="list-style-type: none"> <li>• Added sentence to first subparagraph, "...Safetran's FLX-4000 LED..."</li> </ul> <p>Page 6-2, paragraph 6.3</p>

Version	Release Date	Details of Change(s)
F	09-10-07	<ul style="list-style-type: none"> <li>• Added wording to second subparagraph, "...on volt meters...", "...measurement..."</li> </ul> <p>Page 6-2, paragraph 6.3</p> <ul style="list-style-type: none"> <li>• Reworded third subparagraph to read, "...This distorted AC waveform condition..."</li> </ul> <p>Page 7-1, paragraph 7.2</p> <ul style="list-style-type: none"> <li>• Added note, "...The power supplies in many LED signals..."</li> </ul> <p>Changed footers to reflect 'Rev F' changes</p> <p>Page 4-38 and 4-39, paragraph 6.4</p> <ul style="list-style-type: none"> <li>• Inserted two intentionally blank pages to support printing of Program and Configure Menus</li> </ul> <p>Page 6-2, paragraph 6.4</p> <ul style="list-style-type: none"> <li>• Inserted new Paragraph 6.4, titled "Meter Reading Conversion Examples"</li> </ul> <p>Page 7-1, paragraph 7.1</p> <ul style="list-style-type: none"> <li>• Changed sentence to end of second paragraph to read "Return the unserviceable unit to Safetran under the Return Material Authorization process, if applicable."</li> </ul> <p>Page 7-2</p> <ul style="list-style-type: none"> <li>• Inserted blank page stating "This page intentionally left blank" to correct pagination issues</li> </ul> <p>Page 7-3, Figure 7-14</p> <ul style="list-style-type: none"> <li>• Replaced with new Troubleshooting Diagram dated 09-06-07</li> <li>• Changed page size to 11 X 17 to make it easier to read the troubleshooting diagram</li> </ul> <p>Page 7-4</p> <ul style="list-style-type: none"> <li>• Inserted blank page stating "This page intentionally left blank" to correct pagination issues</li> </ul> <p>Page 7-5, paragraph 7-3</p> <ul style="list-style-type: none"> <li>• Changed the first paragraph to read: "The SSCC is continuously self-checking its hardware and software for faults. Fault conditions may be severe or informational. When a severe fault is detected, the LCD displays a <b>SHUTDOWN #xxx</b> message where <b>xxx</b> is the Error Code. The fault is entered into the summary log. If a fault occurs repeatedly, the unit must be replaced and returned to Safetran under the Return Material Authorization process."</li> <li>• Changed the second paragraph to read: "Some faults are informational faults and will not cause a SHUTDOWN; however, they are still entered into the summary log. Some faults may be correctable by user action. Table 7-1 lists those faults and the action to take."</li> </ul>

Version	Release Date	Details of Change(s)																																								
		<p>Page 7-5, Table 7-1</p> <ul style="list-style-type: none"> <li>Replaced all occurrences of “If error persists, unit requires servicing” with “If error persists, replace unit and return it to Safetran under the Return Material Authorization process.”</li> <li>Added Shutdown Error Code 394 that states “1E2 03/08/07 16:27:47.2 Processor communication error, Unable to communicate with slave processor” in the Sample Summary Log Messages Column, “394” in the Shutdown Error Code Column, and “Replace unit and return it to Safetran under the Return Material Authorization process” in the Corrective Action Column</li> </ul> <p>Page 7-6, paragraph 7.4</p> <ul style="list-style-type: none"> <li>Changed paragraph number 7.2 to 7.4</li> </ul> <p>Page 7-7, paragraph 7.5</p> <p><b>Inserted new paragraph 7.5 that states: ‘Troubleshooting Maintenance Call (MC) Light Problems</b></p> <p><b>Several operations in the SSCC system will turn-off the MAINT CALL (MC) light. This procedure assumes:</b></p> <ul style="list-style-type: none"> <li>The warning devices are not activated and SSCC unit is healthy.</li> <li>No track is out-of-service (A track OOS turns off the MC light)</li> <li>MC operation is being placed in service for the first time and wiring must be checked.</li> <li>MCF files that effect the Maintenance Call (MC) Lights</li> </ul> <p><b>When the parameters listed in Table 0-1 are energized via the Menus, the MC lights will not illuminate. Before beginning Troubleshooting procedures, ensure that the parameters depicted in Table 0-1 are not the cause of the MC Light being out.</b></p> <ul style="list-style-type: none"> <li>Verify the status of the listed parameters prior to performing normal troubleshooting procedures for the listed MCF’s.”</li> </ul> <p>Page 7-7, Table 7-2</p> <ul style="list-style-type: none"> <li>Inserted Table 7-2</li> </ul> <p style="text-align: center;">Table 7-2: MCF / MC Light-Out Cross Reference Chart</p> <table border="1" data-bbox="537 1409 1336 1833"> <thead> <tr> <th data-bbox="537 1409 727 1535">MCF</th> <th data-bbox="727 1409 906 1535">SSCC Unhealthy</th> <th data-bbox="906 1409 1118 1535">Low Battery, if Low Battery Detection enabled</th> <th data-bbox="1118 1409 1336 1535">Track taken out of service</th> </tr> </thead> <tbody> <tr> <td>BASIC</td> <td>X</td> <td>X</td> <td></td> </tr> <tr> <td>BASICPLS</td> <td>X</td> <td>X</td> <td>X</td> </tr> <tr> <td>3TRK1WRP</td> <td>X</td> <td>X</td> <td>X</td> </tr> <tr> <td>2TRK2WRP</td> <td>X</td> <td>X</td> <td>X</td> </tr> <tr> <td>2TRKDSTK</td> <td>X</td> <td>X</td> <td>X</td> </tr> <tr> <td>SUPISL</td> <td>X</td> <td>X</td> <td>X</td> </tr> <tr> <td>3TRK2TRN</td> <td>X</td> <td>X</td> <td>X</td> </tr> <tr> <td>2TRK2TRN</td> <td>X</td> <td>X</td> <td>X</td> </tr> <tr> <td>DAXPRMPT</td> <td>X</td> <td>X</td> <td>X</td> </tr> </tbody> </table>	MCF	SSCC Unhealthy	Low Battery, if Low Battery Detection enabled	Track taken out of service	BASIC	X	X		BASICPLS	X	X	X	3TRK1WRP	X	X	X	2TRK2WRP	X	X	X	2TRKDSTK	X	X	X	SUPISL	X	X	X	3TRK2TRN	X	X	X	2TRK2TRN	X	X	X	DAXPRMPT	X	X	X
MCF	SSCC Unhealthy	Low Battery, if Low Battery Detection enabled	Track taken out of service																																							
BASIC	X	X																																								
BASICPLS	X	X	X																																							
3TRK1WRP	X	X	X																																							
2TRK2WRP	X	X	X																																							
2TRKDSTK	X	X	X																																							
SUPISL	X	X	X																																							
3TRK2TRN	X	X	X																																							
2TRK2TRN	X	X	X																																							
DAXPRMPT	X	X	X																																							

Version	Release Date	Details of Change(s)
F.1	3-11-2014	<p>Page 7-8, paragraph 7.5.2  <b>Inserted paragraph 7.5.2 that states: “Troubleshooting Procedures for Maintenance Call (MC) Light Problems.</b>  <b>The following procedure checks the most common items first. If the MAINT CALL light does not turn on after a step, proceed to the next step.</b></p> <ol style="list-style-type: none"> <li>1. Observe MAINT CALL LED on Connector J2 <ul style="list-style-type: none"> <li>• If LED 1 is on, go to step 2.</li> <li>• If LED 1 is off, go to step 3.</li> </ul> </li> <li>2. Determine that the MC light functions by testing the lamp circuit as follows: <ol style="list-style-type: none"> <li>a. Measure DC voltage between <b>B</b> (+ meter lead) and <b>MAINT CALL</b> (MC) out (- meter lead) on the green connector J2. <ul style="list-style-type: none"> <li>♦ If voltage is within 0.5 volts of B, then the lamp or lamp circuit is open and must be repaired.</li> <li>♦ If voltage is less than 1.0 volts, go to next step.</li> </ul> </li> <li>b. Measure between <b>N</b> (- meter lead) and <b>MC</b> (+ meter lead) on the green connector. <ul style="list-style-type: none"> <li>♦ If voltage is within 0.5 volts of B, then the lamp circuit is okay, but the MC output is off. <ul style="list-style-type: none"> <li>◇ If LED 1 is on, replace SSCC</li> <li>◇ If LED 1 is off, go to the next step</li> </ul> </li> </ul> </li> </ol> </li> <li>3. If the SSCC health light is flashing rapidly or off, determine cause or replace SSCC.</li> <li>4. Battery voltage may be low: <ul style="list-style-type: none"> <li>• If <b>Low Battery</b> is set to <b>Enabled</b> in Configuration Menu, verify that the voltage on the battery connector is more than the <b>Low Battery Level</b> shown.</li> </ul> <p><b>If, after following the steps above, the MC lamp stays off, call Safetran Technical Support for further assistance at (800) 793-7233.”</b></p> </li> </ol> <p>Page 8-1, paragraph 8-2, Note</p> <ul style="list-style-type: none"> <li>• Changed Note to read “SSCC MEF software revision 9V546.A06.H or above requires SEAR II MEF software revision 9V645.A01.G or above to establish communications.”</li> </ul> <p>Page A-1, Appendix A</p> <ul style="list-style-type: none"> <li>• Deleted the former Appendix A, titled “Using a Conventional Meter.” The former Appendix B, titled “SSCC IIIA MCF Release History” is renumbered to Appendix A</li> </ul> <p>History Card, Sheet 2 of 2</p> <ul style="list-style-type: none"> <li>• Changed title of History Card to reflect new usage, renaming the title to “SSCC Generic History Card”</li> <li>• Deleted former table “Multimeter Reading Variance From Actual Lamp Voltage” and inserted new table from the updated Paragraph 6.4 continuing with the same table title</li> </ul> <p>Rebrand for Siemens</p>

## Table of Contents

Section	Title	Page
	PROPRIETARY INFORMATION .....	ii
	TRANSLATIONS .....	ii
	WARRANTY INFORMATION .....	ii
	SALES AND SERVICE LOCATIONS.....	ii
	FCC RULES COMPLIANCE .....	ii
	DOCUMENT HISTORY .....	iii
	NOTES, CAUTIONS, AND WARNINGS .....	xxiii
	ELECTROSTATIC DISCHARGE (ESD) PRECAUTIONS .....	xxiv
	GLOSSARY.....	xxv
	SECTION 1 INTRODUCTION.....	1-1
1.1	GENERAL.....	1-1
1.2	EQUIPMENT OVERVIEW .....	1-1
1.2.1	Solid State Crossing Controller III PLUS (SSCC III PLUS) .....	1-1
1.2.1.1	SSCC III PLUS Features.....	1-2
1.2.2	Lighting Surge Panels .....	1-4
1.3	SYSTEM FUNCTIONAL DESCRIPTION.....	1-8
1.3.1	SSCC III PLUS Controls and Indicators .....	1-9
1.3.2	I/O Interface.....	1-11
1.3.2.1	RS-232 Diagnostic Port J5.....	1-12
1.3.2.2	LAN .....	1-13
1.3.3	Standard Sequence of Operation .....	1-14
1.3.4	Crossing Operation in the Event of an SSCC III PLUS Failure .....	1-15
1.3.5	Open Lamp Neutral Wire Detection.....	1-15
1.3.6	Use of Independent Pairs of Lamp Outputs .....	1-16
1.3.7	Cross Wiring Lamp Output Pairs .....	1-16
1.3.8	Use of Multiple Controllers .....	1-16
1.4	SPECIFICATIONS.....	1-17
1.4.1	SSCC III PLUS Specifications .....	1-17
1.4.1.1	SSCC III PLUS Mechanical Specifications.....	1-17
1.4.1.2	SSCC III PLUS Environmental Specifications.....	1-17
1.4.1.3	SSCC III PLUS Site Power Requirements .....	1-17
1.4.1.4	SSCC III PLUS Power Requirements .....	1-18
1.4.1.5	Echelon <sup>®</sup> LAN Interface .....	1-19
1.4.1.6	SSCC III PLUS Operating Specifications .....	1-19
1.4.1.7	SSCC III PLUS Test, Setup and Program Modes .....	1-21

1.4.1.8	SSCC III PLUS Interfaces .....	1-21
1.4.2	Lighting Surge Panel (A91170-1, A91170-2, A91181-1, A91181-2) Specifications .....	1-22
1.4.2.1	Lighting Surge Panel Mechanical Specifications .....	1-22
1.4.2.2	Lighting Surge Panel I/O Interface .....	1-23
1.5	ORDERING INFORMATION .....	1-24
1.5.1	SSCC III PLUS 40-Ampere Unit, A91190 .....	1-24
1.5.2	SSCC III PLUS 20-Ampere Unit, A91195 .....	1-24
1.5.3	Lighting Surge Panels .....	1-25
1.5.4	Mating Connectors .....	1-25
SECTION 3	SSCC III PLUS MODULE CONFIGURATION FILES (MCF) .....	3-1
3.1	GENERAL .....	3-1
3.2	MCF DESCRIPTIONS .....	3-2
3.2.1	BASIC MCF .....	3-3
3.2.1.1	BASIC MCF Description .....	3-3
3.2.1.2	BASIC MCF Operation .....	3-4
3.2.1.3	BASIC MCF Physical Inputs .....	3-5
3.2.1.4	Optional Loss-Of-Shunt Timer .....	3-5
3.2.2	BASICPLS MCF .....	3-6
3.2.2.1	BASICPLS MCF Description .....	3-6
3.2.2.2	BASICPLS MCF Operation .....	3-6
3.2.2.3	BASICPLS MCF Physical Inputs .....	3-7
3.2.2.4	Optional Loss-Of-Shunt Timer .....	3-7
3.2.3	3TRK1WRP MCF .....	3-8
3.2.3.1	3TRK1WRP MCF Description .....	3-8
3.2.3.2	3TRK1WRP MCF Operation .....	3-8
3.2.3.3	3TRK1WRP MCF Physical Inputs .....	3-9
3.2.3.4	Optional Loss-Of-Shunt Timer .....	3-9
3.2.4	2TRK2WRP MCF .....	3-10
3.2.4.1	2TRK2WRP MCF Description .....	3-10
3.2.4.2	2TRK2WRP MCF Operation .....	3-10
3.2.4.3	2TRK2WRP MCF Physical Inputs .....	3-11
3.2.4.4	Optional Loss-Of-Shunt Timer .....	3-11
3.2.5	2TRKDSTK MCF .....	3-12
3.2.5.1	2TRKDSTK MCF Description .....	3-12
3.2.5.2	2TRKDSTK MCF Operation .....	3-12
3.2.5.3	2TRKDSTK MCF Physical Inputs .....	3-14
3.2.5.4	Stick Cancellation Timer .....	3-14
3.2.5.5	Optional Loss-Of-Shunt Timer .....	3-15
3.2.5.6	Test Switch Mode .....	3-15
3.2.6	SUPISL MCF .....	3-16
3.2.6.1	SUPISL MCF Description .....	3-16
3.2.6.2	SUPISL MCF Operation .....	3-16
3.2.6.3	SUPISL MCF Physical Inputs .....	3-17
3.2.6.4	Optional Loss-Of-Shunt Timer .....	3-17



3.2.6.5	Supplemental Island Timer .....	3-17
3.2.7	3TRK2TRN MCF .....	3-18
3.2.7.1	3TRK2TRN MCF Description.....	3-18
3.2.7.2	3TRK2TRN MCF Operation .....	3-18
3.2.7.3	3TRK2TRN MCF Physical Inputs.....	3-19
3.2.7.4	Optional Loss-Of-Shunt Timer .....	3-19
3.2.8	2TRK2TRN MCF .....	3-20
3.2.8.1	2TRK2TRN MCF Description.....	3-20
3.2.8.2	2TRK2TRN MCF Operation .....	3-20
3.2.8.3	2TRK2TRN MCF Physical Inputs.....	3-21
3.2.8.4	Optional Loss-Of-Shunt Timer .....	3-21
3.2.9	DAXPRMT MCF .....	3-22
3.2.9.1	DAXPRMT MCF Description.....	3-22
3.2.9.2	DAXPRMT MCF Operation .....	3-22
3.2.9.3	DAXPRMT MCF Physical Inputs.....	3-24
3.2.9.4	Optional Loss-Of-Shunt Timer .....	3-24
3.3	USING 2GC OUTPUT/INPUT #7 MODE (2GC/I7) .....	3-24
3.3.1	2GC Normal Operation (Both 20 Amp and 40 Amp Models).....	3-25
3.3.2	2GC Inverted Operation (40 Amp Models Only).....	3-25
3.3.3	2GC Traffic Signal Simultaneous Preemption Relay Drive (40 Amp Models Only) .....	3-25
3.3.4	2GC Traffic Signal Advance Preemption Relay Drive (40 Amp Models Only) .....	3-25
3.3.5	2GC Active Beacon Relay Drive for Advance Warning Signs (40 Amp Models Only) .....	3-26
3.3.6	Input 7 in the Preemption Modes.....	3-27
SECTION 4 DISPLAYS & MENU DESCRIPTIONS .....		4-1
4.1	GENERAL.....	4-1
4.2	MAIN MENU .....	4-1
4.2.1	PROGRAM Menu.....	4-2
4.2.1.1	Program Lamp Flash Rate .....	4-3
4.2.1.2	Program Gates Used (not available for BASIC MCF) .....	4-3
4.2.1.3	Program Gate Delay Timers .....	4-3
4.2.1.4	Program Gate Rising Bell Off.....	4-4
4.2.1.5	Program Enabled Inputs .....	4-4
4.2.1.6	Program 2GC/I7 MODE (40-Amp Unit Only) (not available for BASIC or DAXPRMT).....	4-6
4.2.1.7	Program Advance Pre-emption Time (40-Amp unit only) (not available for BASIC) .....	4-7
4.2.1.8	Program Minimum Activation Time .....	4-7
4.2.1.9	Program Beacon Delay Time (40-Amp unit only)(n/a for BASIC and DAXPRMT MCFs) .....	4-8
4.2.1.10	Program Island Delay Time (40-Amp unit only) (2TRKDSTK MCF only) .....	4-9
4.2.1.11	Program Stick Release Time (2TRKDSTK MCF only) .....	4-9

4.2.1.12	Program Supplemental Island Time (SUPISL MCF only).....	4-9
4.2.1.13	Program Input 7 (40-Amp Unit Only)(2TRKDSTK MCF only).....	4-10
4.2.1.14	Program Test Switch (40-Amp Unit Only)(2TRKDSTK MCF only) ..	4-10
4.2.1.15	Program Enabled Outputs (40-Amp Unit Only) .....	4-11
4.2.1.16	Program Time.....	4-11
4.2.1.17	Program Date.....	4-11
4.2.1.18	Program Daylight Saving.....	4-12
4.2.1.19	Program Password.....	4-12
4.2.1.20	Program Set to Default.....	4-13
4.2.1.21	Exit Program Mode.....	4-14
4.2.2	CONFIGURE Menu.....	4-14
4.2.2.1	Configure Loss-Of-Shunt Timers For Each Input .....	4-15
4.2.2.2	Configure MCF.....	4-16
4.2.2.3	Configure ATCS Address.....	4-17
4.2.2.4	Configure Low Battery.....	4-18
4.2.2.5	Configure Aux. I/O.....	4-18
4.2.2.6	Configure Detect Lamp Neutral Wire .....	4-19
4.2.2.7	Configure Set To Default.....	4-19
4.2.2.8	Exit Configure Mode.....	4-20
4.2.3	SETUP LAMP VOLTAGES Menu .....	4-20
4.2.3.1	Selecting the Proper Voltmeter for Setting Lamp Voltage .....	4-22
4.2.3.2	Setup Output 1 L1 (Output A) .....	4-22
4.2.3.3	Setup Output 1 L2 (Output A) .....	4-23
4.2.3.4	Setup Output 2 L1 (Output B, 40-Amp Units Only).....	4-23
4.2.3.5	Setup Output 2 L2 (Output B, 40-Amp Units Only).....	4-23
4.2.3.6	Exit Setup Mode.....	4-23
4.2.4	TEST CONFIGURE Menu.....	4-24
4.2.4.1	Test Configure Lamp Test Cancel Timer .....	4-24
4.2.4.2	Test Configure Lamp Test Delay Timer .....	4-25
4.2.4.3	Test Configure Lamp Test On Timer.....	4-26
4.2.4.4	Test Configure Set To Default.....	4-26
4.2.4.5	Exit Test Configure Mode.....	4-27
4.2.5	TEST Menu .....	4-27
4.2.5.1	Test Lamps Steady .....	4-29
4.2.5.2	Test Flash Lamps.....	4-29
4.2.5.3	Test Timed Lamps .....	4-29
4.2.5.4	Test Timed Lamps Repeat.....	4-30
4.2.5.5	Test Activate Crossing .....	4-30
4.2.5.6	Exit Test Mode .....	4-30
4.2.6	QUERY Menu.....	4-31
4.2.6.1	Query Software Versions .....	4-31
4.2.6.2	Query Configuration Versions .....	4-33
4.2.7	SERVICE Menu.....	4-34
SECTION 5 APPLICATION PROGRAMMING .....		5-1
5.1	GENERAL.....	5-1
5.2	PROGRAMMING THE SSCC III PLUS.....	5-2

5.2.1	Order of Steps to Program the SSCC III PLUS .....	5-2
5.2.1.1	Verify/Select the Desired MCF .....	5-3
5.2.1.2	Using the PROGRAM Menu .....	5-6
5.2.1.3	Using the CONFIGURE Menu .....	5-13
5.2.1.4	Using the TEST CONFIGURE Menu .....	5-16
5.2.2	Using the Out of SERVICE Menu (Not available in the BASIC MCF)..	5-17
SECTION 6 LAMP VOLTAGE ADJUSTMENT & TESTING .....		6-1
6.1	GENERAL.....	6-1
6.2	LAMP VOLTAGE DRIVE .....	6-1
6.3	USE OF LED TYPE LAMPS .....	6-2
6.4	METER READING CONVERSION EXAMPLES.....	6-2
6.4.1	Lamp Voltage Measurement Example 1 .....	6-3
6.4.2	Lamp Voltage Measurement Example 2 .....	6-3
6.5	LAMP VOLTAGE ADJUSTMENT PROCEDURE .....	6-3
6.5.1	Adjustment of FAR Gate Flasher Lamps (Output A) .....	6-6
6.5.1.1	1L1 Adjustment (FAR Gate).....	6-6
6.5.1.2	1L2 Adjustment (FAR Gate).....	6-7
6.5.2	Adjustment of FAR Gate Flasher Lamps (Output B, 40-Amp unit only).	6-7
6.5.2.1	2L1 Adjustment (FAR Gate).....	6-7
6.5.2.2	2L2 Adjustment (FAR Gate).....	6-8
6.5.3	Adjustment of NEAR Gate Flasher Lamps (Output A).....	6-9
6.5.4	Adjustment of NEAR Gate Flasher Lamps (Output B, 40-Amp unit only)	6-10
6.6	FLASHING LIGHT SIGNAL ALIGNMENT .....	6-11
6.7	SYSTEM VERIFICATION TESTS.....	6-12
6.7.1	SSCC III PLUS Crossing Operational Check List & Tests.....	6-12
SECTION 7 - TROUBLESHOOTING .....		7-1
7.1	GENERAL.....	7-1
7.2	TROUBLESHOOTING SSCC III PLUS ERRORS .....	7-1
7.3	SSCC ERROR CODES .....	7-5
7.4	LAMP NEUTRAL WIRE OPEN.....	7-6
7.5	Troubleshooting Maintenance Call (MC) Light Problems.....	7-7
7.5.1	MCF files that effect the Maintenance Call (MC) Lights .....	7-7
7.5.2	Troubleshooting Procedure for Maintenance Call (MC) Light Problems	7-7
SECTION 8 EXTERNAL COMMUNICATON .....		8-1
8.1	GENERAL.....	8-1
8.2	LAN.....	8-1
8.3	RS-232 DIAGNOSTIC PORT J5.....	8-2
8.3.1	SSCC III PLUS Serial Port To PC .....	8-2
8.3.2	SSCC III PLUS Serial Port To SEA/R .....	8-4

SECTION 9 SOFTWARE VERIFICATION & UPGRADE .....	9-1
9.1 GENERAL.....	9-1
9.2 SOFTWARE UPGRADE.....	9-1
9.3 SOFTWARE VERIFICATION .....	9-1
9.3.1 Query Menu.....	9-2
9.3.1.1 Query Software Versions .....	9-2
9.3.1.2 Query Configuration Versions .....	9-3
9.3.1.3 Exit Query Mode .....	9-3
SECTION 10 APPLICATION DRAWINGS .....	10-1
10.1 GENERAL.....	10-1
APPENDIX A SSCC III PLUS MCF RELEASE HISTORY .....	A-1

## LIST OF FIGURES

<u>Figure No.</u>	<u>Title</u>	<u>Page</u>
Figure 1-1.	SSCC III PLUS 40-Ampere Unit, A91190.....	1-3
Figure 1-2.	SSCC III PLUS 20-Ampere Unit, A91195.....	1-3
Figure 1-3.	Isolated Gate Control Lighting Surge Panel, A91181-1 (for 20-Amp or 40-Amp unit) .....	1-6
Figure 1-4.	Isolated Gate Control Lighting Surge Panel, A91181-2 (for 40-Amp unit only) .....	1-6
Figure 1-5.	Common Return Lighting Surge Panel, A91170-1 (for 20-Amp or 40-Amp unit)...	1-6
Figure 1-6.	Common Return Lighting Surge Panel, A91170-2 (for 40-Amp unit only).....	1-7
Figure 1-7.	Typical Isolated Gate Control .....	1-7
Figure 1-8.	Typical Common Return Gate Control .....	1-8
Figure 1-9.	Crossing Controller Basic Architecture .....	1-9
Figure 3-1.	Typical XR Inputs for BASIC MCF.....	3-4
Figure 3-2.	Typical XR Inputs for BASICPLS MCF .....	3-6
Figure 3-3.	Typical XR Inputs for 3TRK1WRP MCF .....	3-8
Figure 3-4.	Typical XR Inputs for 2TRK2WRP MCF.....	3-10
Figure 3-5.	Typical XR Inputs for 2TRKDSTK MCF.....	3-12
Figure 3-6.	Typical Example for 2TRKDSTK MCF .....	3-13
Figure 3-7.	Typical XR Inputs for SUPISL MCF.....	3-16
Figure 3-8.	Typical XR Inputs for 3TRK2TRN MCF .....	3-18
Figure 3-9.	Typical XR Inputs for 2TRK2TRN MCF .....	3-20
Figure 3-10.	Typical XR Inputs for DAXPRMT MCF .....	3-23
Figure 4-1.	SSCC III PLUS Main Menu .....	4-1
Figure 4-2.	Typical Master/Slave Application .....	4-18
Figure 4-3.	Typical Setup Lamp Voltages Menu Flow Diagram .....	4-21
Figure 4-4.	Typical Test Configure Menu Flow Diagram.....	4-24
Figure 4-5.	Timed and Repeat Lamp Test Cycles .....	4-25
Figure 4-6.	Typical Test Menu Flow Diagram .....	4-28
Figure 4-7.	Typical Query Software Versions Menu Flow Diagram.....	4-32
Figure 4-8.	Typical Query Configuration Versions Menu Flow Diagram .....	4-33

Figure 4-9. Typical Out Of Service Input .....	4-35
Figure 4-10. Typical Service Menu Flow Diagram .....	4-37
Figure 4-11. BASIC MCF Configure Menu Flow Diagram.....	4-40
Figure 4-12. BASIC MCF Program Menu Flow Diagram .....	4-41
Figure 4-13. BASICPLS MCF Configure Menu Flow Diagram.....	4-42
Figure 4-14. BASICPLS MCF Program Menu Flow Diagram.....	4-43
Figure 4-15. 3TRK1WRP MCF Configure Menu Flow Diagram.....	4-44
Figure 4-16. 3TRK1WRP MCF Program Menu Flow Diagram.....	4-45
Figure 4-17. 2TRK2WRP MCF Configure Menu Flow Diagram.....	4-46
Figure 4-18. 2TRK2WRP MCF Program Menu Flow Diagram.....	4-47
Figure 4-19. 2TRKDSTK MCF Configure Menu Flow Diagram.....	4-48
Figure 4-20. 2TRKDSTK MCF Program Menu Flow Diagram .....	4-49
Figure 4-21. SUPISL MCF Configure Menu Flow Diagram.....	4-50
Figure 4-22. SUPISL MCF Program Menu Flow Diagram .....	4-51
Figure 4-23. 3TRK2TRN MCF Configure Menu Flow Diagram.....	4-52
Figure 4-24. 3TRK2TRN MCF Program Menu Flow Diagram.....	4-53
Figure 4-25. 2TRK2TRN MCF Configure Menu Flow Diagram.....	4-54
Figure 4-26. 2TRK2TRN MCF Program Menu Flow Diagram.....	4-55
Figure 4-27. DAXPRMT MCF Configure Menu Flow Diagram.....	4-56
Figure 4-28. DAXPRMT MCF Program Menu Flow Diagram.....	4-57
Figure 5-1. SSCC III PLUS Main Menu .....	5-1
Figure 6-1. Typical Lamp Wiring.....	6-5
Figure 7-1: SSCC III PLUS Troubleshooting Diagram .....	7-3
Figure 8-1. SSCC III PLUS to SEAR II Using LAN .....	8-1
Figure 8-2. SSCC III PLUS Serial Port To PC COM Port .....	8-2
Figure 8-3. Example Log Data on a PC.....	8-3
Figure 8-4. SSCC III PLUS Serial Port to SEAR.....	8-4
Figure 10-1: Typical Two-Gate Application (Isolated Gate Return) using 20-Ampere Crossing Controller With Lightning/Surge Panel A91181-1 (Page 1 of 2).....	10-4
Figure 10-2: Typical Two-Gate Application (Isolated Gate Return) using 20-Ampere Crossing Controller With Lightning/Surge Panel A91181-1 (Page 2 of 2).....	10-5
Figure 10-3: Typical Two-Gate Application (Isolated Gate Return) With Cantilever Flashers, 40-Ampere Crossing Controller With Lightning/Surge Panels A91181-1 and A91181-2 (Page 1 of 2) .....	10-6
Figure 10-4: Typical Two-Gate Application (Isolated Gate Return) With Cantilever Flashers, 40-Ampere Crossing Controller With Lightning/Surge Panels A91181-1 and A91181-2 (Page 2 of 2).....	10-7
Figure 10-5: Typical Four-Gate Application (Isolated Gate Return) Using 40-Ampere Crossing Controller With Lightning/Surge Panels A91181-1 And A91181-2 (Page 1 of 2) .....	10-8
Figure 10-6: Typical Four-Gate Application (Isolated Gate Return) Using 40-Ampere Crossing Controller With Lightning/Surge Panels A91181-1 And A91181-2 (Page 2 of 2).....	10-9
Figure 10-7: Typical Two-Gate Application (Common Gate Return) Using 20-Ampere Crossing Controller With Lightning/Surge Panel A91170-1 (Page 1 of 2).....	10-10
Figure 10-8: Typical Two-Gate Application (Common Gate Return) Using 20-Ampere Crossing Controller With Lightning/Surge Panel A91170-1 (Page 2 of 2).....	10-11
Figure 10-9: Typical Two-Gate Application (Common Gate Return) With Cantilever Flashers, 40-Ampere Crossing Controller With Lightning/Surge Panels A91170-1 and A91170-2 (Page 1 of 2).....	10-12
Figure 10-10: Typical Two-Gate Application (Common Gate Return) With Cantilever Flashers, 40-Ampere Crossing Controller With Lightning/Surge Panels A91170-1 and A91170-2 (Page 2 of 2).....	10-13

Figure 10-11: Typical Four-Gate Application (Common Gate Return) Using 40- Ampere Crossing Controller With Lighting/Surge Panels A91170-1 and A911 70-2 (Page 1 of 2) ..... 10-14

Figure 10-12: Typical Four-Gate Application (Common Gate Return) Using 40- Ampere Crossing Controller With Lighting/Surge Panels A91170-1 and A911 70-2 (Page 2 of 2) ..... 10-15

## LIST OF TABLES

<u>Table No.</u>	<u>Title</u>	<u>Page</u>
Table 1-1.	SSCC III PLUS Controls and Indicators .....	1-10
Table 1-2.	SSCC III PLUS I/O Interface .....	1-11
Table 3-1.	Available MCFs .....	3-2
Table 3-2.	BASIC MCF Inputs .....	3-5
Table 3-3.	BASICPLS MCF Inputs .....	3-7
Table 3-4.	3TRK1WRP MCF Inputs .....	3-9
Table 3-5.	2TRK2WRP MCF Inputs .....	3-11
Table 3-6.	2TRKDSTK MCF Inputs .....	3-14
Table 3-7.	SUPISL MCF Inputs .....	3-17
Table 3-8.	3TRK2TRN MCF Inputs .....	3-19
Table 3-9.	2TRK2TRN MCF Inputs .....	3-21
Table 3-10.	DAXPRMT MCF Inputs .....	3-24
Table 4-1.	SSCC III PLUS Displays for Enabling Inputs (by MCF) .....	4-5
Table 4-2.	2GC/I7 Options .....	4-6
Table 4-3.	Activation Inputs Configurable for LOS Based on Selected MCF .....	4-15
Table 4-4.	Default Configuration Values.....	4-20
Table 5-1.	Available MCFs .....	5-5
Table 6-1:	Multimeter Reading Variance from Actual Lamp Voltages.....	6-2
Table 7-1:	SSCC Summary Log Messages .....	7-5
Table 7-2:	MCF / MC Light-Out Cross Reference Chart.....	7-7

## NOTES, CAUTIONS, AND WARNINGS

Throughout this manual, notes, cautions, and warnings are frequently used to direct the reader's attention to specific information. Use of the three terms is defined as follows:

### **WARNING**

**WARNING**

**INDICATES A POTENTIALLY HAZARDOUS SITUATION WHICH, IF NOT AVOIDED, COULD RESULT IN DEATH OR SERIOUS INJURY. WARNINGS ALWAYS TAKE PRECEDENCE OVER NOTES, CAUTIONS, AND ALL OTHER INFORMATION.**

### **CAUTION**

**CAUTION**

REFERS TO PROPER PROCEDURES OR PRACTICES WHICH IF NOT STRICTLY OBSERVED, COULD RESULT IN A POTENTIALLY HAZARDOUS SITUATION AND/OR POSSIBLE DAMAGE TO EQUIPMENT. CAUTIONS TAKE PRECEDENCE OVER NOTES AND ALL OTHER INFORMATION, EXCEPT WARNINGS.

### **NOTE**

**NOTE**

Generally used to highlight certain information relating to the topic under discussion.

If there are any questions, contact Siemens Rail Automation Corporation Application Engineering.

## **ELECTROSTATIC DISCHARGE (ESD) PRECAUTIONS**

Static electricity can damage electronic circuitry, particularly low voltage components such as the integrated circuits commonly used throughout the electronics industry. Therefore, procedures have been adopted industry-wide which make it possible to avoid the sometimes invisible damage caused by electrostatic discharge (ESD) during the handling, shipping, and storage of electronic modules and components. Siemens Rail Automation has instituted these practices at its manufacturing facility and encourages its customers to adopt them as well to lessen the likelihood of equipment damage in the field due to ESD. Some of the basic protective practices include the following:

- Ground yourself before touching card cages, assemblies, modules, or components.
- Remove power from card cages and assemblies before removing or installing modules.
- Remove circuit boards (modules) from card cages by the ejector lever only. If an ejector lever is not provided, grasp the edge of the circuit board but avoid touching circuit traces or components.
- Handle circuit boards by the edges only.
- Never physically touch circuit board or connector contact fingers or allow these fingers to come in contact with an insulator (e.g., plastic, rubber, etc.).
- When not in use, place circuit boards in approved static-shielding bags, contact fingers first. Remove circuit boards from static-shielding bags by grasping the ejector lever or the edge of the board only. Each bag should include a caution label on the outside indicating static-sensitive contents.
- Cover workbench surfaces used for repair of electronic equipment with static dissipative workbench matting.
- Use integrated circuit extractor/insertor tools designed to remove and install electrostatic-sensitive integrated circuit devices such as PROM's (OK Industries, Inc., Model EX-2 Extractor and Model MOS-40 Insertor (or equivalent) are highly recommended).
- Utilize only anti-static cushioning material in equipment shipping and storage containers.

For information concerning ESD material applications, please contact the Technical Support Staff at 1-800-793-7233. ESD Awareness Classes and additional ESD product information are also available through the Technical Support Staff.



## GLOSSARY

Advance Preemption:	Notification of an approaching train is forwarded to the highway traffic signal controller by railroad equipment for a period of time prior to activating the railroad active warning devices.
Advance Preemption Time:	This period of time is the difference in the Maximum Preemption Time required for highway traffic signal operation and the Minimum Warning Time needed for railroad operation and is called the Advance Preemption Time. This time delay is determined by the highway agency after an engineering study of the intersection and grade crossing
ATCS:	Acronym for <u>Advanced Train Control System</u>
Beacon:	A highway traffic signal with one or more signal sections that operates in a flash mode. In this manual, the beacons referred to are used as supplemental emphasis to a highway-railroad grade crossing advance warning sign.
CFG:	Abbreviation for Configure.
CPU:	<u>Central Processor Unit</u> – A controller module (Master or Slave) for the SSCC IV unit.
CRC:	<u>Cyclical Redundancy Check</u> – An error check code in which a check key is calculated and appended to the data. It is used to check for corrupted data.
DCE:	<u>Data Communications Equipment</u> – Any device (modem, terminal, printer, etc.) that merely transports data over a transmission facility (establishes, maintains, and terminates a session) but does not originate or consume data.
DT Utility:	Acronym for <u>Diagnostic Terminal Utility</u>
DTE:	<u>Data Terminal Equipment</u> – Any device (computer, etc.) that originates or consumes data over a transmission facility (can act as data source, data sink, or both).
Echelon®:	The company that created the twisted pair LAN used by the SSCC IV. “Echelon” is also used to refer to the LAN itself.
EGOM	<u>Exit Gate Operating Mode</u> – A dynamic mode in which the exit gate operation is based on the presence and detection of vehicles between the stop bar or entrance gate and the exit gate.
Entrance Gate:	A gate used at the entrance to a highway-railroad grade crossing, which is designed to release and lower by gravity from the full vertical position to the horizontal position under a loss of power condition or when the control energy (GC) is removed.
Exit Gate:	A gate used at the exit from a highway-railroad grade crossing with Four Quadrant Gates to restrict wrong direction vehicular movements, which is designed to raise by gravity from the horizontal position to a vertical position great enough to allow vehicle clearing under a loss of power condition or when the control energy (GC) is removed.

## GLOSSARY (continued)

FAR GATE:	On the same surge panel, the 'Far Gate' is the flashing light signal or gate with the largest voltage drop in the cable circuit. In general, if both signals have the same number and type of lamps and the same size cable conductors, the 'Far Gate' is the location with the longest cable run. The 'Far Gate' circuit on the surge panel <u>does not</u> have an adjustable resistor in series with L1 and L2 to provide voltage adjustment.
Flash Memory:	A type of non-volatile memory that can be reprogrammed in-circuit via software.
FLS:	Acronym for <u>Flashing Light Signal</u>
FPM:	Acronym for <u>Flashes Per Minute</u>
Gate Delay Period:	The programmable time period from when the lights begin to flash until the gates begin to descend.
GC:	<u>Gate Control</u> – Output(s) from the SSCC IV unit for controlling the crossing gates. These outputs are isolated from battery.
GD:	<u>Gate Down</u> – An input to the SSCC IV unit to indicate when the crossing gates are in the “down” position.
GCP:	<u>Grade Crossing Predictor</u> – A train detection device used as part of a highway-railroad grade crossing warning system to provide a relatively uniform warning time.
GP:	<u>Gate Position</u> – An input to the SSCC IV unit to indicate when the crossing gates are in the “up” position (83 to 90 degrees).
Highway-Railroad Grade Crossing Advance Warning Sign:	A traffic control sign (round yellow sign with RR and a black X) placed by the highway agency in advance of many highway-railroad grade crossings
Interconnection:	The electrical connection between the railroad active warning system and the traffic signal controller for the purpose of preemption.
LAN:	<u>Local Area Network</u> – A limited local network where the data transfer medium is generally wires or cable. For the SSCC IV, it refers to the individual twisted pair Echelon LAN connection to other equipment such as an external event recorder, etc.
LCD:	Acronym for <u>Liquid Crystal Display</u>
LED:	<u>Light-Emitting-Diode</u> – A solid-state indicator.
LOS:	Acronym for <u>Loss-Of-Shunt</u>
MBT:	Abbreviation for Master Boot file

## GLOSSARY (continued)

MCF:	<u>Module Configuration File</u> – The train detection program (also referred to as “application program”) that defines what the SSCC does. Some models of a crossing controller have several application programs pre-loaded inside them. The application program is in the form of a file that has to be downloaded into the controller or comes pre-loaded inside the controller. The term “MCF” refers to the actual file that is loaded into the controller and also is used to refer to the application logic.
MEF:	<u>Master Executable File</u> – Executive software running in the SSCC IV unit for the primary (master) processor. The master processor is responsible for overall operation of the SSCC IV and internal communication with the slave processors.
Megger:	A piece of high voltage test equipment used for verifying the integrity of cable insulation.
MS:	<u>Motion Sensor</u> – A system for detecting train movement on a track.
NEAR GATE:	On the same surge panel, the 'Near Gate' is the flashing light signal or gate with the lowest voltage drop in the cable circuit. In general, if both signals have the same number and type of lamps and the same size cable conductors, the 'Near Gate' is the location with the shortest cable run. The 'Near Gate' circuit on the surge panel has an adjustable resistor in series with L1 and L2 that provides additional voltage adjustment.
Neutral Wire:	The wire in a three wire flashing light signal circuit that shunts current from the 'off' lamp. In SSCC applications, the neutral wire is the N wire to the FLS.
Node:	The transceiver interface of a piece of equipment connected to the Echelon® LAN.
OS:	Abbreviation for Out-of-Service.
Pocket PC:	A small, handheld computer running a Microsoft® Personal Digital Assistant operating system.
Preemption:	Transfer of normal operation of traffic signals to a special control mode.
PRG:	Abbreviation for Program.
PSO-III:	<u>Phase Shift Overlay III</u> – A Safetran track circuit (transmitter at one location and receiver at another location) that supplies track occupancy information for crossing warning devices and other train or vehicle detection systems.
RMS:	<u>Root Mean Square</u> – The square root of the average of the squares of all the values. RMS is always the same or just a little larger than the average of the unsigned values, and is sometimes referred to as the amount of DC required to produce an equivalent amount of heat in the same load.
RS-232:	EIA interface between DTE and DCE, employing unbalanced serial binary data interchange at up to 20 Kbps/50 ft. Uses DB-25 connector (or optional DB-9 connector). Can interface with ITU specifications V.24, V.28, or V.10. Distance from DTE to DCE is generally less than 60 meters.
SBT:	Abbreviation for Slave Boot file.

## GLOSSARY (continued)

SEF:	<u>Slave Executable File</u> – Executive software running in the SSCC IV unit for the secondary (slave) processors. The slave processors (two for 20-Amp units, or four for 40-Amp units) are responsible for the SSCC IV outputs.
Simultaneous Preemption:	Notification of an approaching train is forwarded to the highway traffic signal controller unit or assembly and railroad active warning devices at the same time.
TC:	Abbreviation for Test Configure.
TMR:	Abbreviation for Timer.
True rms AC + DC:	A test equipment setting that allows the measurement of rms voltage for non-sinusoidal wave shapes by measuring the AC + DC components.
Wrap Around:	A track circuit, or combination of track circuits, that extend to, or beyond, the limits of a GCP approach, which provides train detection. When used in relay equivalent logic, the wrap around relay contact, WAR, is in parallel with the GCP relay contact in the XR circuit.
XR:	Designation for railroad crossing relay, or equivalent crossing activation circuit.

# SECTION 1

## INTRODUCTION

### 1.1 GENERAL

This is the instruction and installation manual for the Safetran® Solid-State Crossing Controller III PLUS (SSCC III PLUS). The following controller units are available:

- 40-ampere unit (part number A91190)
- 20-ampere unit (part number A91195)

The 20-ampere units (Single Model) provide one set of Lamp, Gate Control and Bell outputs while the 40-ampere units (Dual Model) provide two sets.

### 1.2 EQUIPMENT OVERVIEW

The SSCC III PLUS is designed to operate in conjunction with a train detection device such as a grade crossing predictor (GCP), motion sensor (MS), PSO-III or other equipment supplying an XR relay drive. The SSCC III PLUS receives vital crossing control and gate position inputs and provides total control of the lamps, bells, and gates at a grade crossing. It incorporates microprocessor controlled solid-state switching and safety monitoring technology into a fully integrated package.

The SSCC III PLUS is not a replacement for the SSCC IIIA but is an alternative controller that contains major specialized application enhancements. The SSCC III PLUS contains all the features and operations of the SSCC IIIA, plus it provides various new user-selectable on-board application configurations. Each selectable train detection configuration, such as Double Track Directional Stick Logic with programmable vital stick cancellation timers, or GCP with Wrap Around logic with programmable LOS timers, etc., reconfigures the use of the seven SSCC III PLUS inputs and associated logic for the desired application. In addition, the PLUS menu system is expanded to include simultaneous or advanced (timed) traffic signal pre-emption output drive logic, and a new main menu option called SERVICE that can be used to program any inputs (tracks) Out-Of-Service permanently or for a timed duration.

The following paragraphs provide descriptions of the SSCC III PLUS assemblies and the associated lighting/surge panels. Figures 1-1 and 1-2 present illustrations of the SSCC III PLUS units.

#### 1.2.1 Solid State Crossing Controller III PLUS (SSCC III PLUS)

The SSCC III PLUS is housed in an aluminum case with a black epoxy powder-coat finish. The unit can be wall or backboard mounted as well as rack-mounted (19-inch rack, or 23-inch rack with optional base – see Ordering Information). Front panel connectors accommodate all external connections and interconnecting wiring to the lighting/surge panel(s).

### **1.2.1.1 SSCC III PLUS Features**

The SSCC III PLUS exhibits the following features:

- 40-ampere units support 4 gates with lamps and bells, or 2 gates with lamps and bells and cantilever with lamps
- 20-ampere units support 2 gates with lamps and bells
- Pre-loaded user-selectable train detection programs (also called application programs or MCFs)
- Programmable track Out-Of-Service feature
- Isolated gate control
- Voltage regulated adjustable lamp outputs
- Programmable vital control inputs (up to 8 including one input for GP)
- Non-volatile real-time clock with optional daylight savings
- On-board event memory
- Programmable lamp flash rate
- Optional synchronized lamp flashing of multiple units
- Programmable gate control delay (40-Ampere unit includes second GC, inverted GC or pre-emption relay drive, or advance warning sign beacon relay drive)
- Optional “bell off” condition while gate is rising
- Enhanced Crossing and lamp test modes
- Configurable application and test timers
- Optional Loss-Of -Shunt selection with configurable timers
- A/B outputs enabled (40-Amp units only)
- Password protection (can be enabled/disabled)
- Programmable low battery indication threshold
- Echelon<sup>®</sup> connectivity to other Safetran products, such as the SEAR II event analyzer.
- Maintenance Call output

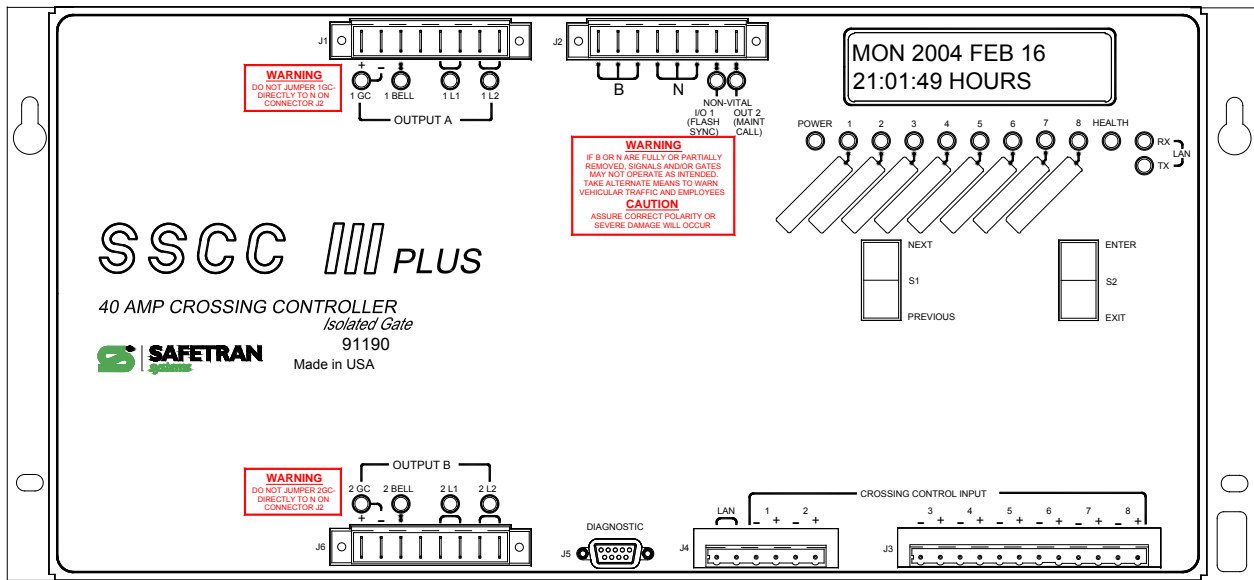

SSCCIIIPLUS\_91190  
04-07-04 (Rev 3-17-2014)

Figure 1-1. SSCC III PLUS 40-Ampere Unit, A91190

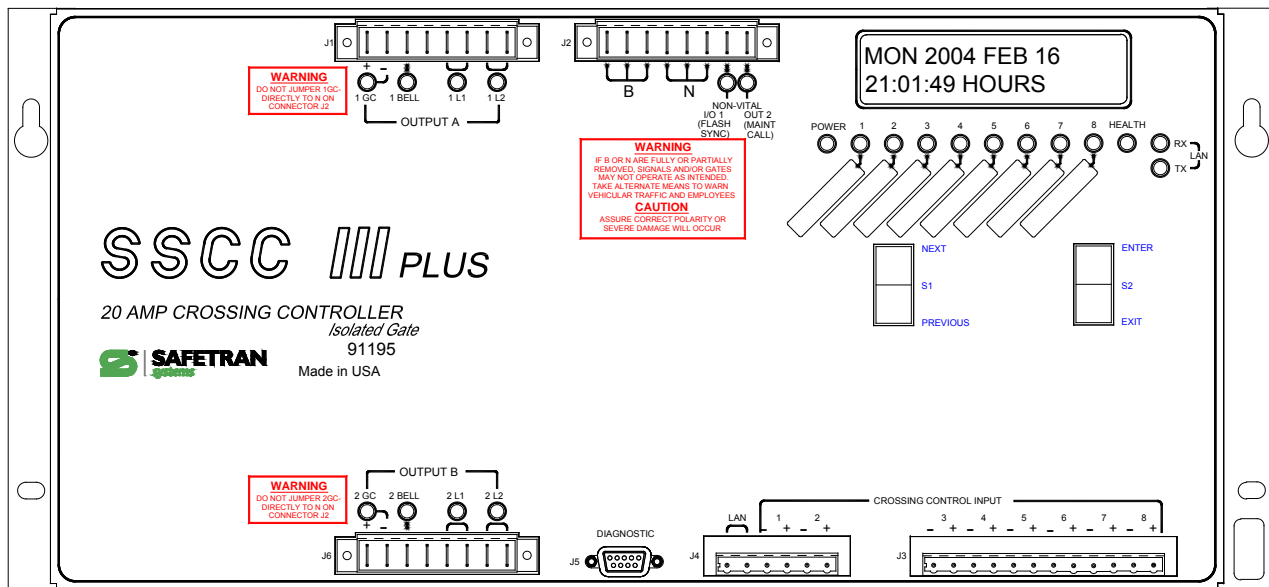

SSCCIIIPLUS\_91195  
04-07-04 (Rev 3-17-2014)

Figure 1-2. SSCC III PLUS 20-Ampere Unit, A91195

An additional feature of the SSCC III PLUS is its small size and light weight. Relays and wiring normally required for conventional highway grade crossing installations (including the XR, slow release gate control, and flasher relays) are replaced by heavy-duty solid-state switches. Gate delay and GP flashing lamp control are also part of the microprocessor solid-state vital logic circuit.

The SSCC III PLUS provides a user-programmable, highly efficient regulated lamp voltage to minimize the chances of the lamp voltage dropping below acceptable limits when the AC power is off or when the battery charger has failed. This feature also eliminates seasonal adjustment of lamp voltages when using temperature compensated battery chargers. The regulated lamp drive is a pulse-width modulated voltage with an AC component and a DC component. A “TRUE RMS AC+DC” meter is required to accurately read the pulse-modulated lamp voltage (such as a Fluke 187 or 189 digital multimeter).



**WARNING**

**TO CORRECTLY MEASURE LAMP VOLTAGE, THE VOLTMETER MUST HAVE A SETTING FOR “TRUE RMS AC + DC”.**

Conventional multimeters may be used, however, the voltage reading will vary from “true rms AC + DC”. The variance is not a set percentage and is dependent on battery voltage. A conversion chart cross-referencing several conventional meters is provided in Appendix A.

Independent lamp voltage adjustment resistors are provided for the “near” set of flasher lamps (shortest cable) to compensate for unequal voltage drops between the two cables. To aid in aiming lamps and adjusting lamp voltage, a TEST menu provides for lamps to be lit continuously. However, if a train arrives while in this mode, the crossing warning devices will operate as intended.

During normal operation, system health is monitored by the CPU, and a MAINT CALL contact is supplied on a connector on the front panel to control a maintenance call (MAINT CALL) lamp or crossing monitor device. If a problem occurs or a track is Out-Of-Service, the MAINT CALL output is turned off.

### 1.2.2 Lighting Surge Panels



**CAUTION**

**THE SSCC III PLUS SYSTEM REQUIRES EXTERNAL INPUT AND OUTPUT PRIMARY SURGE PROTECTION.**

Interface between the SSCC III PLUS unit and external crossing gates, bells, and lamp circuit wiring can be provided by Lighting/Surge Panels. There are two basic types of Lighting/Surge Panels for the 20-amp and 40-amp crossing controller units: common return and isolated gate control. Lighting Surge Panel part numbers are as follows:



- A91170-1 Common return gate control (used with 20-Amp & 40-Amp units, A91190, A91195).
- A91170-2 Common return gate control (used with 40-Amp unit, A91190).
- A91181-1 Isolated gate control (used with 20-Amp & 40-Amp units, A91190, A91195).
- A91181-2 Isolated gate control (used with 40-Amp unit, A91190).

For isolated gate control, a single A91181-1 panel (figure 1-3) is used with the 20-ampere unit (A91195), and both an A91181-1 and an A91181-2 panel (figure 1-4) are generally used with the 40-ampere unit (A91190). Refer to figure 1-7 for typical isolated gate control wiring.

For common return gate control, a single A91170-1 panel (figure 1-5) is used with the 20-ampere unit (A91195), and both an A91170-1 and an A91170-2 panel (figure 1-6) are generally used with the 40-ampere unit (A91190). Refer to figure 1-8 for typical common return gate control wiring.

The panels contain arresters and equalizers for surge protection with standard AREMA binding posts provided for underground cable connections to the flashing lights, gates, and bells. Battery circuit protectors for the lighting/surge panel are included on the A91170-1 and A91181-1 surge panels. The A91170-2 and A91181-2 panels are similar to their dash-one versions, but do not include the battery circuit surge protection, as their purpose is to extend the dash-one panels for the dual output crossing controllers.

All the lighting surge panels provide insulated links in all underground cable connections to allow quick circuit isolation for testing and making measurements without requiring removal of site cabling.

All the lighting surge panels provide adjustable resistors in the NEAR GATE Lamp 1 and Lamp 2 circuits to compensate for different lengths of cabling to the crossing flashing lamps.

The lighting surge panels also provide steering diodes for the Gate Control output from the SSCC III PLUS to provide isolation between the two crossing gate controls.

The lighting surge panels can be wall- or backboard-mounted, and rack-mounted (23-inch rack).

Underground wiring for the gates and flashers is routed into the wayside enclosure and connected to the lighting/surge panel(s). Interconnect wiring is then run from the lighting/surge panel(s) directly to the crossing controller.

INTRODUCTION

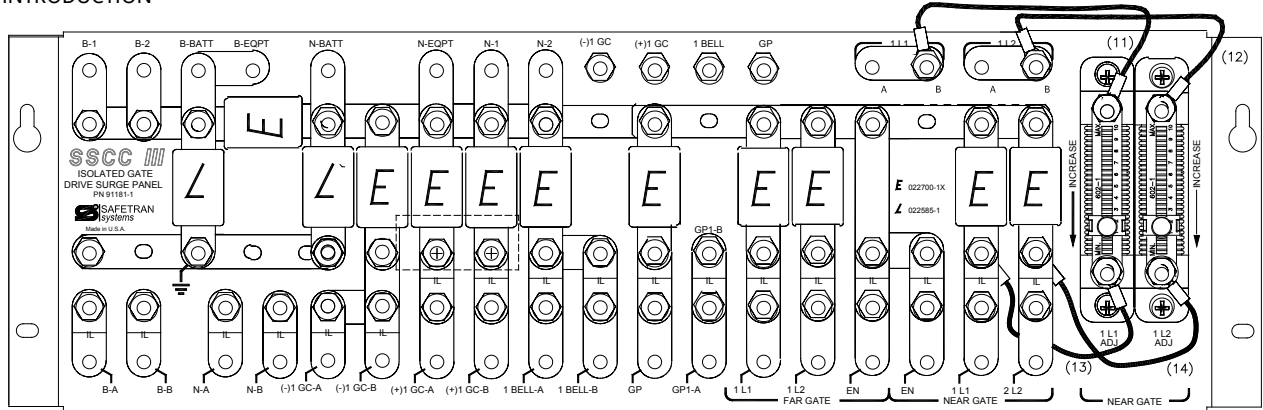

ISGDSP2.DWG  
02-20-02

Figure 1-3. Isolated Gate Control Lighting Surge Panel, A91181-1 (for 20-Amp or 40-Amp unit)

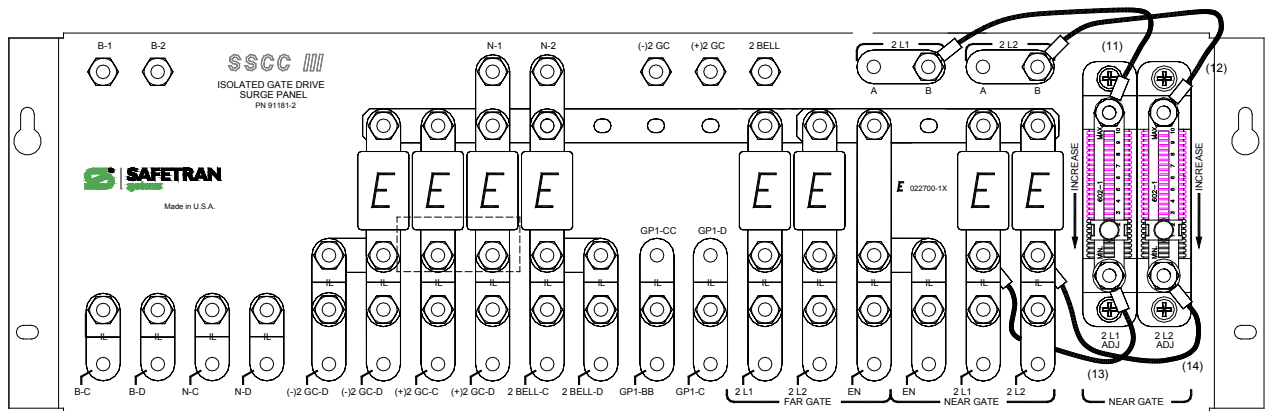

91181-2SG.DWG  
03-12-04 (Rev 1-20-14)

Figure 1-4. Isolated Gate Control Lighting Surge Panel, A91181-2 (for 40-Amp unit only)

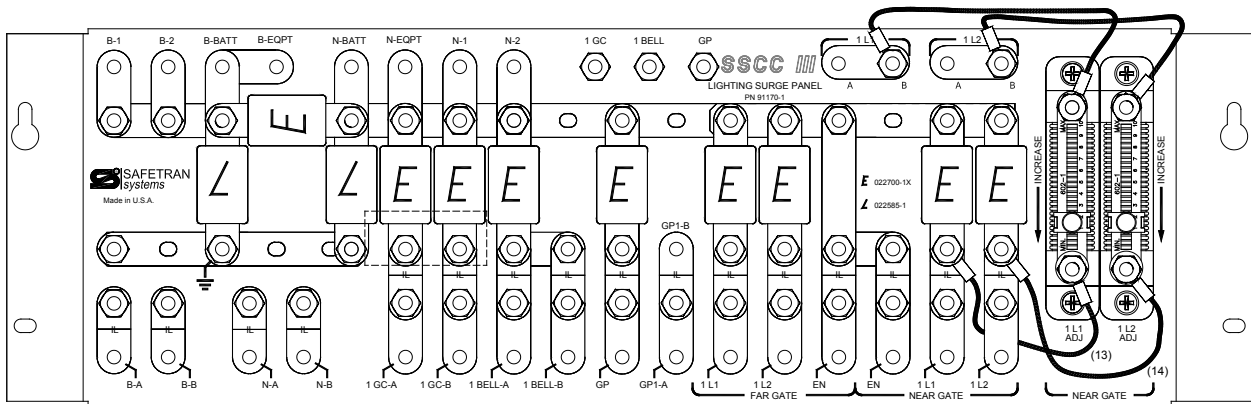

SURGNL2.DWG  
02-25-02

Figure 1-5. Common Return Lighting Surge Panel, A91170-1 (for 20-Amp or 40-Amp unit)

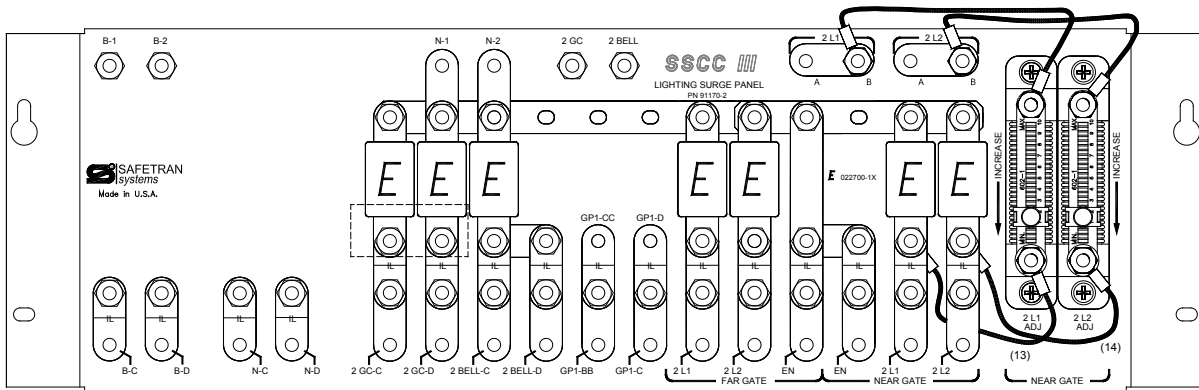

SURGPL3.DWG  
03-04-02

**Figure 1-6. Common Return Lighting Surge Panel, A91170-2 (for 40-Amp unit only)**

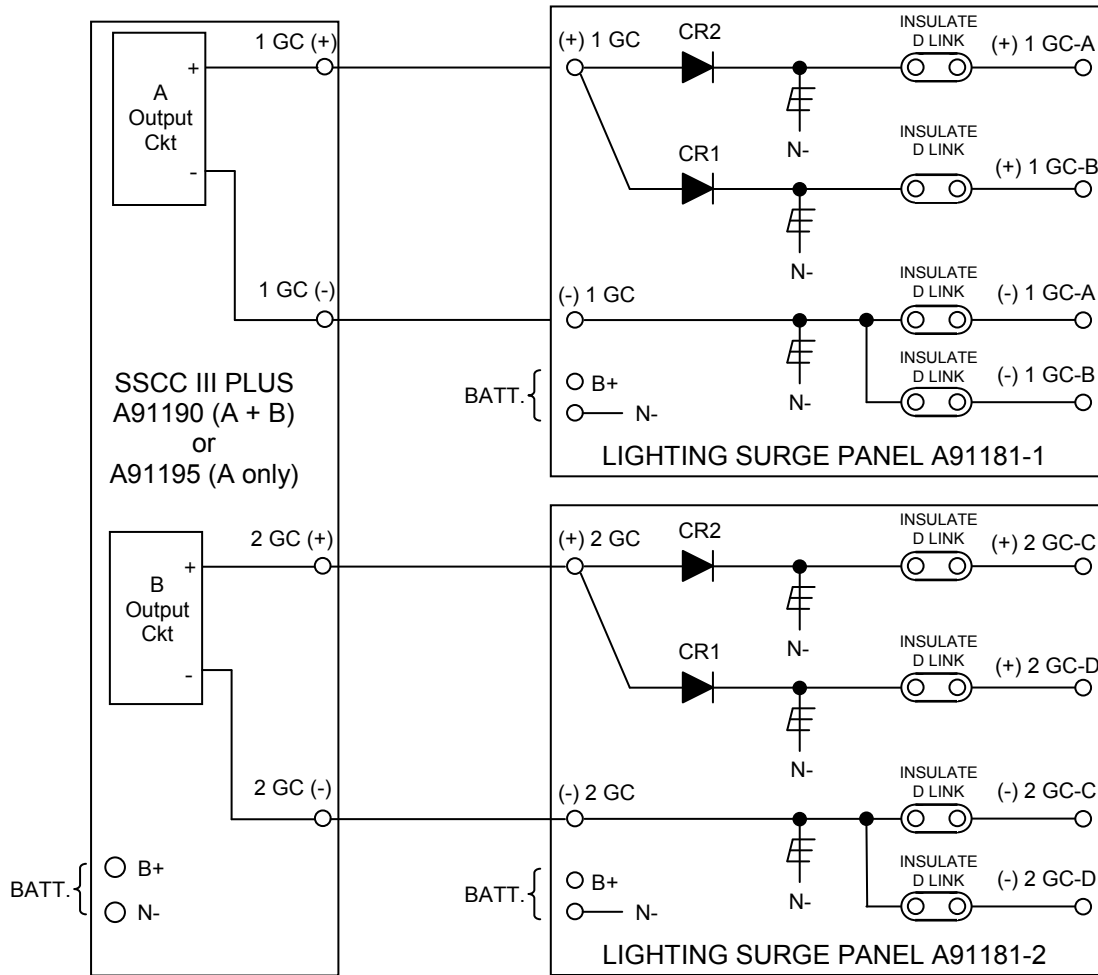

**Figure 1-7. Typical Isolated Gate Control**

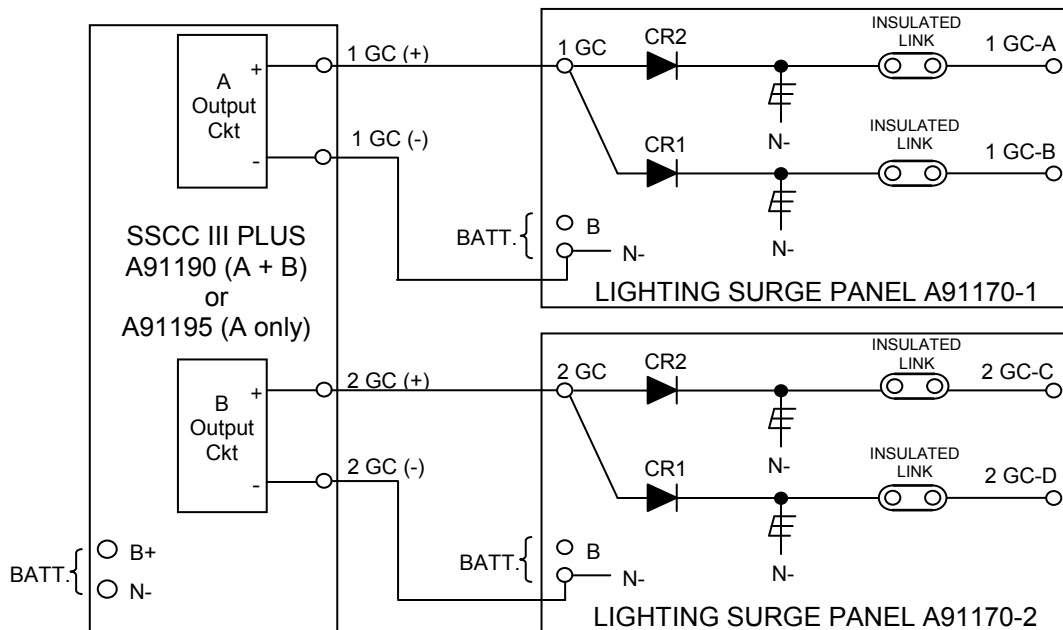

**Figure 1-8. Typical Common Return Gate Control**



**WARNING**

**WARNING**

**DO NOT JUMPER 1 GC (-) OR 2 GC (-) DIRECTLY TO “N” ON SSCC CONNECTOR J2.**

**1.3 SYSTEM FUNCTIONAL DESCRIPTION**

The 20-ampere SSCC III PLUS units (A91195) are designed to supply a maximum of 20 amperes of lamp current. This normally accommodates two sets of flashers (with front and back lights) and two crossing gates for a total of eight 25-watt lamps lit at any given time. The 40-ampere SSCC III PLUS units (A91190) are designed to supply a maximum of 40 amperes of lamp current. This normally accommodates four sets of flashers (with front and back lights) and four gates for a total of 16 25-watt lamps lit at any given time (using both A Output and B Output).

The basic architecture of the SSCC is shown in figure 1-9. Each 20-Amp Controller contains one master and two slave processors, and each 40-Amp Controller contains one master and four slave processors. Each processor has its own software and purpose. All processors are constantly communicating with each other and running individual self-tests. Each slave processor provides a distinct flashing lamp output such as 1L1, 1L2, etc. while the Master CPU controls all other functions. A 12-volt output from the 1 GC or the 2 GC requires both corresponding slave CPUs and the Master CPU to be in agreement in an internal Vital AND Gate.

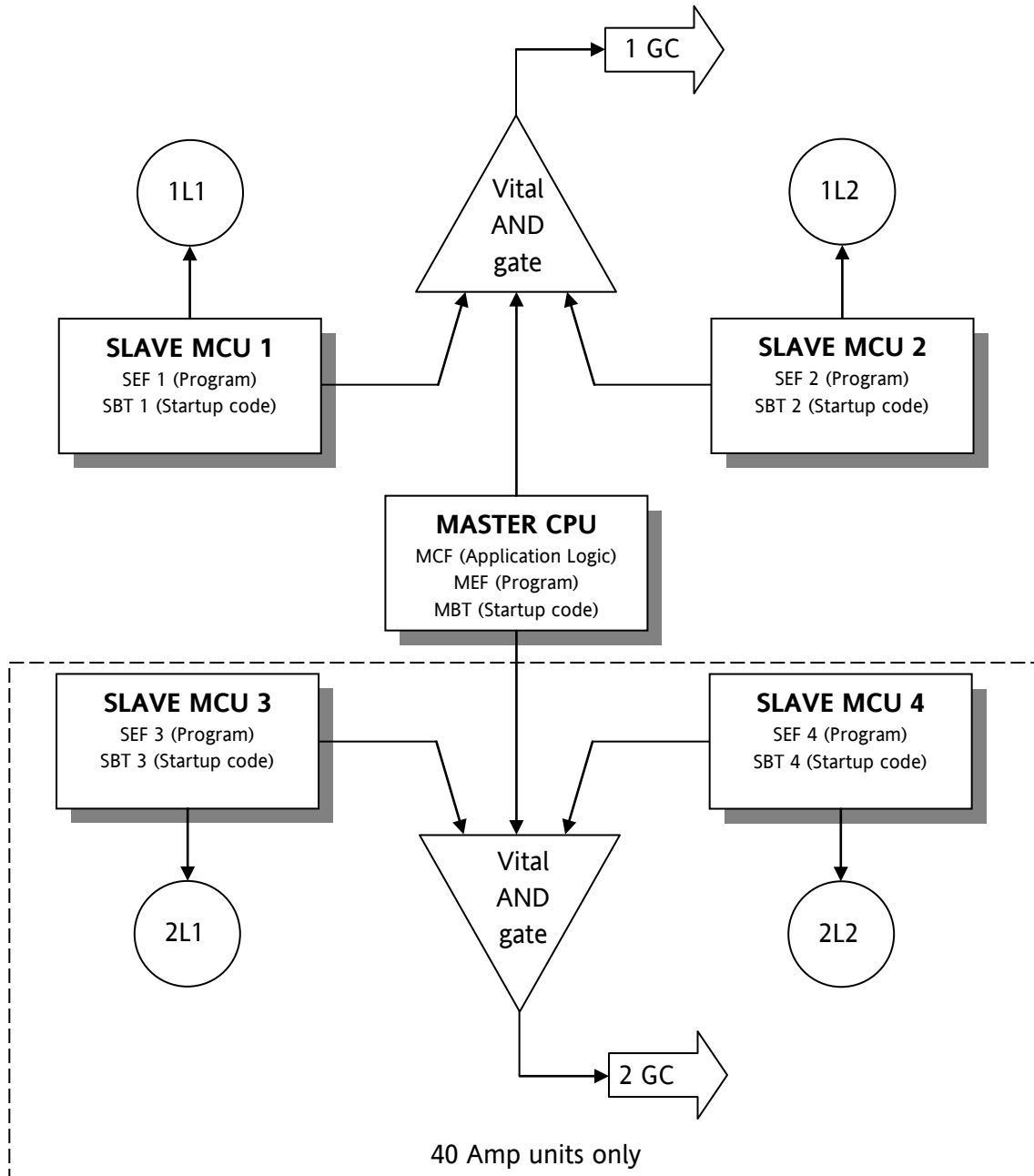

**Figure 1-9. Crossing Controller Basic Architecture**

### 1.3.1 SSCC III PLUS Controls and Indicators

The SSCC III PLUS front panel contains a liquid crystal display, two rocker panel switches, and a number of LED indicators. Table 1-1 lists the controls and indicators and gives a brief description of each.

**Table 1-1. SSCC III PLUS Controls and Indicators**

<b>Indicator/Control</b>	<b>Type</b>	<b>Description</b>
(main display)	Liquid Crystal Display	32-character (in 2 rows) LCD with microprocessor-controlled heater
<b>POWER</b>	LED	Directly monitors B input (Battery). Lit to indicate presence of battery voltage.
<b>1 thru 8</b> (programmable status LEDs)	LED	Eight status LEDs independently CPU-enabled and provided with labels for identification. Crossing activation inputs are 1 through 7. A lighted status indicates an unactivated input, off indicates activated. Flashing indicates Out-Of-Service for that input. Input 8 is generally used for the GP input (gate position – lit when gate arms are in the vertical position).
<b>HEALTH</b>	LED	Driven by CPU, flashes at a slow rate ( $\approx 1$ Hz) when system is fully operational, and at a fast rate ( $\approx 8$ Hz) when faulted.
<b>LAN RX (red)</b>	LED	Driven by CPU, flashes to indicate LAN RX activity.
<b>LAN TX (green)</b>	LED	Driven by CPU, flashes to indicate LAN TX activity.
<b>1GC (Output A)</b>	LED	Lit when gate relays are energized and off when Output Bank A gates are commanded to drop.
<b>1 BELL (Output A)</b>	LED	Lit when Output Bank A bells are commanded to ring.
<b>1L1 (Output A)</b>	LED	Lit when Output Bank A L1 lamps are commanded to light.
<b>1L2 (Output A)</b>	LED	Lit when Output Bank A L2 lamps are commanded to light.
<b>2GC (Output B)</b>	LED	Lit when gate relays are energized and off when Output Bank B gates are commanded to drop.
<b>2 BELL (Output B)</b>	LED	Lit when Output Bank B bells are commanded to ring.
<b>2L1 (Output B)</b>	LED	Lit when Output Bank B L1 lamps are commanded to light.
<b>2L2 (Output B)</b>	LED	Lit when Output Bank B L2 lamps are commanded to light.
<b>NON-VITAL I/O 1 (FLASH SYNC)</b>	LED	Lit to indicate that J2, pin 7 is active. This I/O is programmed as a non-vital output (default), flash sync in (slave unit), or flash sync out (master unit) for synchronizing lamp flashing of multiple SSCC III crossing controllers.
<b>NON-VITAL OUT 2 (MAINT CALL)</b>	LED	Lit steady when maintenance call output (J2, pin 8) is active. Off to indicate a failure, or Out Of Service.
<b>NEXT/PREVIOUS</b>	Switch	Input command to main CPU to move forward or backward through the menu or increase/decrease values.
<b>ENTER/EXIT</b>	Switch	Input command to main CPU to execute a function or to exit from a submenu.

### 1.3.2 I/O Interface

The SSCC III PLUS front panel provides connectors for the external interfaces (see table 1-2). Refer to *Specifications*, paragraph 1.4, for the interface specifications.

**Table 1-2. SSCC III PLUS I/O Interface**

Ref. Des.	Pin	I/O	Description	
	1	1GC+ (Output A)	Gate 1 Output positive (Output Bank A - A91190, A91195 units)	
	2	1GC- (Output A)	Gate 1 Output negative (Output Bank A - A91190, A91195 units)	
	3	1 BELL (Output A)	Bell Output for Output Bank A	
	4	(n/a)	(not used)	
	5	1 L1	Lamp Output 1 for Output Bank A (all units)	
	6			
	7	1 L2	Lamp Output 2 for Output Bank A (all units)	
	8			
J2	1	B	Positive Battery input	
	2			
	3			
	4	N	Negative Battery input or return	
	5			
	6			
		7	NON-VITAL I/O 1 (FLASH SYNC)	Flash Sync I/O is designated as a non-vital output (default), sync in (slave unit), or sync out (master unit) for synchronizing lamp flashing of multiple SSCC crossing controllers. This output is referenced to negative battery.
		8	NON-VITAL OUTPUT 2 (MAINT CALL)	Provides an output indication when an SSCC III PLUS failure occurs. Output is normally a sink to N- and becomes a high impedance when a failure occurs.
J3	1	Input 3-	Crossing Controller input 3 negative	
	2	Input 3+	Crossing Controller input 3 positive	
	3	Input 4-	Crossing Controller input 4 negative	
	4	Input 4+	Crossing Controller input 4 positive	
	5	Input 5-	Crossing Controller input 5 negative	
	6	Input 5+	Crossing Controller input 5 positive	
	7	Input 6-	Crossing Controller input 6 negative	
	8	Input 6+	Crossing Controller input 6 positive	
	9	Input 7-	Crossing Controller input 7 negative	
	10	Input 7+	Crossing Controller input 7 positive	
	11	Input 8-	Crossing Controller input 8 negative - Generally GP negative	
	12	Input 8+	Crossing Controller input 8 positive - Generally GP positive	
J4	1	LAN	Echelon <sup>®</sup> LAN input 1 (polarity arbitrary)	
	2	LAN	Echelon <sup>®</sup> LAN input 2 (polarity arbitrary)	
	3	Input 1-	Crossing Controller input 1 negative	
	4	Input 1+	Crossing Controller input 1 positive	
	5	Input 2-	Crossing Controller input 2 negative	
	6	Input 2+	Crossing Controller input 2 positive	

Continued on next page

**Table 1-2 Concluded**

Ref. Des.	Pin	I/O	Description
J5	1	DCD	RS-232 serial interface- Carrier Detect <b>not</b> used
	2	TXD	RS-232 serial interface- Transmit Data
	3	RXD	RS-232 serial interface- Receive Data
	4	DTR	RS-232 serial interface- Data Terminal Ready <sup>[2]</sup>
	5	GND	RS-232 serial interface- Signal Ground
	6	DSR	RS-232 serial interface- Data Set Ready <sup>[2]</sup>
	7	RTS	RS-232 serial interface- Request To Send <b>not</b> used
	8	CTS	RS-232 serial interface- Clear To Send <sup>[2]</sup>
	9	RI	RS-232 serial interface- Ring Indicator <b>not</b> used
J6 <sup>[1]</sup>	1	2GC+ (Output B)	Gate 2 Output positive (Output Bank B - A91190 unit only)
	2	2GC- (Output B)	Gate 2 Output negative (Output Bank B - A91190 unit only)
	3	2 BELL (Output B)	Bell Output for Output Bank B
	4	(n/a)	(not used)
	5	2 L1	Lamp Output 1 for Output Bank B (A91190 units only)
	6		
	7	2 L2	Lamp Output 2 for Output Bank B (A91190 units only)
	8		

[1] Output B LEDs and Output connector J6 are not present on 20-ampere units.

[2] 2-wire plus ground RS-232 configuration only (no handshaking). DTR, DSR, and CTS internally jumpered for use by DTE (if required).

### 1.3.2.1 RS-232 Diagnostic Port J5

The RS-232 Diagnostic port is configured as DCE, to communicate with a diagnostic terminal or other DTE such as a PC.

The serial port can be used for the following functions:

- Updating software using the DT (Diagnostic Terminal) utility
- SSCC III PLUS configuration and diagnostics using the DT utility
- Obtaining the internal log
- Viewing log data in real time

The DT utility is available on CD-ROM from Siemens Customer Service, along with the DT user manual. The DT utility allows the user to perform the following:

#### Updating Software (see WARNING below)

To update SSCC III PLUS software, connect J5 to a laptop PC running Safetran's DT utility. Refer to Section 9, *Software Verification & Upgrade* for information.



SSCC III PLUS Configuration and Diagnostics (see WARNING below)

To change SSCC III PLUS configuration or perform diagnostics, connect J5 to a laptop PC running Safetran's DT utility. The functionality of the SSCC III PLUS front panel is also provided in the DT utility.

**WARNING**

**WHILE UPDATING SOFTWARE OR CHANGING THE CONFIGURATION, THE CROSSING GATES ARE DOWN WITH LAMPS FLASHING AND BELLS RINGING (REGARDLESS OF THE STATE OF THE VITAL CROSSING CONTROL INPUTS). TAKE ADEQUATE PRECAUTIONS TO WARN PERSONNEL, PEDESTRIANS, TRAINS AND OTHER VEHICLES IN THE AREA UNTIL PROPER SYSTEM OPERATION HAS BEEN VERIFIED.**

Obtaining the internal log

The SSCC III PLUS contains memory for recording events. Designed as a diagnostic tool, the memory space is large enough to record the last 8 train moves. These last 8 train moves can be downloaded by connecting a laptop PC running the DT utility to the J5 serial port. This data can be stored as a file. Connect J5 to a laptop PC and use Safetran's DT utility to download the log.

Viewing log data in real time

To view the events in real time with oldest events being replaced by the newest, connect a laptop PC running a terminal emulation application to the J5 serial port. Safetran's DT utility can also be used to examine event data.

**1.3.2.2 LAN**

The SSCC III PLUS is capable of communicating via non-vital messages with external equipment using the Echelon<sup>®</sup> LAN interface. One such application is to use Safetran's SEAR II, part number A80273, to log messages from the SSCC III PLUS. By connecting via the LAN, all events can be recorded on the SEAR II. This allows a user to record significantly more information than can be stored in the internal log of the SSCC III PLUS.

The SEAR II, connected via the LAN to the SSCC III PLUS, must be programmed with the ATCS address of the SSCC III PLUS. Connect the SSCC III PLUS LAN terminals of connector J4 (polarity is arbitrary) to the ECH terminals of connector J1 on the SEAR II.

For LAN communications, a valid ATCS address (refer to Section 4, paragraph 4.2.2.3) must be programmed into the SSCC III PLUS.

Refer to Section 8, *External Communication*, for information on external communications using the LAN.

### 1.3.3 Standard Sequence of Operation

**NOTE**

**NOTE**

The sequence described here is for a SSCC III PLUS unit configured as a SSCC IIIA. Since the SSCC III PLUS unit allows multiple pre-loaded application programs to be selected, the actual sequence of operation will depend on which application has been selected.

When a train is detected, the input to the SSCC III PLUS drops and the following basic controller sequence is initiated:

1. The crossing control input LED on the front panel of the SSCC III PLUS is extinguished.
2. The crossing signals begin to flash and the L1 and L2 lamps on the front panel of the SSCC III PLUS begin to flash.
3. Concurrent with the flashers operating, the crossing bell(s) begin to ring and the 1 BELL LED (also the 2 BELL LED for the 40-Amp unit) on the front panel of the SSCC III PLUS is lit.
4. A nominal 12 volts to the crossing gate relays is removed after the programmed gate delay has run its time causing the gates to descend. The 1GC LED (also the 2GC LED for the 40-Amp unit) is extinguished to indicate gate operation.
5. As the gates begin to descend, the GP input drops to zero and the LED on the front panel associated with the GP input (generally input #8) is extinguished.

When the activation input to the controller is restored (nominal 12 volts), the following sequence occurs:

1. The crossing control input LED lights.
2. The crossing gates begin to rise and the flashers continue to flash. The LEDs 1 L1 and 1 L2 (also 2 L1 and 2 L2 for the 40-Amp unit) continue to flash until the crossing gates are returned to the vertical position.
3. The bell(s) may or may not be ringing as the gates rise, depending upon the SSCC III PLUS programming.
4. The GP input is restored, the GP LED lights, and the flashers stop flashing.

### 1.3.4 Crossing Operation in the Event of an SSCC III PLUS Failure

Each SSCC III PLUS flashing lamp output (1L1 and 1L2 in both 20 and 40-ampere units plus 2L1 and 2L2 in 40-ampere units) is controlled by an individual processor and these processors are in turn synchronized by a master processor. In addition, each processor is constantly running self-diagnostic tests which results in complete on-line testing of the SSCC III PLUS operation. These tests include lamp driver circuitry, lamp sense circuitry, bell output circuitry, gate output circuitry, flash memory, and RAM.

If a critical failure is detected, appropriate action is taken to immediately flash the lamps and bring down the gates. As an example, if a lamp driver failure is detected in one of the flashing lamp outputs of a 20-ampere SSCC III PLUS (1L1 for this example), then one lamp of a flashing pair would be in the failure state (either on steady or off steady) while the other lamp (controlled by 1L2) would continue to flash. Extending this same example to a 40-ampere SSCC III PLUS unit, the 1L1 lamp would be in the failure state while the lamps controlled by 1L2, 2L1 and 2L2 would continue to flash.



**WARNING**

**IF B OR N ARE FULLY OR PARTIALLY REMOVED, SIGNALS AND/OR GATES MAY NOT OPERATE AS INTENDED. TAKE ALTERNATE MEANS TO WARN VEHICULAR TRAFFIC AND EMPLOYEES.**



**WARNING**

**REMOVING INPUT POWER FROM THE SSCC III PLUS UNIT WILL CAUSE THE GATE(S) TO DROP BUT THE LAMPS AND BELLS WILL NOT BE ACTIVATED.**

### 1.3.5 Open Lamp Neutral Wire Detection

To detect if all neutral wires to the lamps driven by an output have become open (a rare occurrence), the SSCC III PLUS performs an open neutral wire test at the beginning of each activation phase. If all neutral wires to the lamps driven by Output A or Output B are detected as open (which causes the lamps to be connected in series), the SSCC III PLUS reacts as follows:

1. The duty cycles of the affected enabled lamp outputs (1L1 and 1L2 for Output A, 2L1 and 2L2 for Output B) are reduced from 50% to 25%, which causes both lamps to flash in unison.
2. The pulse-width modulation of the output is increased to 90%, which raises the true rms AC + DC voltage to 1.5 volts below the battery voltage. The result is the lamps flash in unison at a voltage greater than one half of the normal voltage.
3. The SSCC III PLUS turns off the output to the MAINT CALL lamp.
4. The HEALTH LED on the controller unit flashes at 8 Hz and the display periodically displays "LAMP NEUTRAL WIRE OPEN".

When the lamp neutral wire connection is corrected, the system reverts to normal operation, but the MAINT CALL lamp remains out until manually reset, or until the next crossing activation. Reset from the TEST menu by selecting TST ACTIVATE XNG (**Warning: the crossing will activate**)

The 'Open Lamp Neutral Wire' detection test may be disabled from the CONFIGURE Menu.

### **1.3.6 Use of Independent Pairs of Lamp Outputs**

AREMA C&S Manual Part 3.1.25 recommends the use of two or more independent pairs of lamp outputs to increase the probability that at least 50% of the lamps are functioning as intended in the unlikely event of a failure of a pair of lamp driver outputs. The SSCC III PLUS 40-Amp unit exceeds this criteria by providing two independent outputs in each pair.

### **1.3.7 Cross Wiring Lamp Output Pairs**

AREMA C&S Manual Part 3.1.25 has an option about cross-wiring the outputs of two independent pairs. The SSCC III PLUS does not need to be cross-wired. Cross wiring is not recommended because the Open Lamp Neutral Wire Detection would not be effective.

### **1.3.8 Use of Multiple Controllers**

When interconnecting multiple crossing controllers, the following connections must be made:

- If separate batteries are used to supply power to the controllers, the negative sides of the batteries must be connected together to complete the external flash-sync circuit.
- The GP input from a gate mechanism must be connected to the controller that controls the lamps on that gate mast.

At locations where the signals controlled by separate controllers are not separated by a median, the GP inputs from all gates should be connected to all controllers. This arrangement will cause all lights to flash in the event all gates are not vertical.

At locations where the signals controlled by separate controllers are separated by a median, the GP inputs from all gates on the same side of the median should be connected to the controller(s) activating lights on that side of the median. This arrangement will cause all lights on the same side of the median to flash in the event that all gates on that side of the median are not vertical.

## 1.4 SPECIFICATIONS

### 1.4.1 SSCC III PLUS Specifications

#### 1.4.1.1 SSCC III PLUS Mechanical Specifications

Packaging:	Black powder-coat metal enclosure
Mounting:	Wall, shelf or backboard mount, 19-inch or 23-inch rack mount panel options
Weight:	20-ampere = 9.6 lb (4.32 kg) (approx.), including mating connectors 40-ampere = 11.4 lb (5.13 kg) (approx.), including mating connectors
Depth:	4.125 in (10.48 cm) 4.75 in (12.07 cm) with mating connectors installed
Height:	8.72 in (22.15 cm)
Width:	17.6 in (44.70 cm) (front panel only), 19.0 in (48.26 cm) overall on 19-inch rack mount base 23.0 in (58.42 cm) overall on 23-inch rack mount base

#### 1.4.1.2 SSCC III PLUS Environmental Specifications

Temperature:	-40 °F to +160 °F (-40 °C to +70 °C)
Humidity:	95% non-condensing

#### 1.4.1.3 SSCC III PLUS Site Power Requirements

Input Power:	Customer supplied battery, 6 or 7 cells of lead, 9, 10, or 11 cells of nickel-cadmium. Customer supplied battery charger must be a constant voltage charger capable of 20-Amps continuous for a 20-Amp SSCC III PLUS, and 40-Amps continuous for a 40-Amp SSCC III PLUS.
Ripple Voltage:	1.0V peak-to-peak (maximum)

**1.4.1.4 SSCC III PLUS Power Requirements**

Operating Voltage:	<p>The SSCC III PLUS requires an operating voltage of at least 1.5 volts above the desired lamp output.</p> <p>The SSCC III PLUS operates normally between 9 and 16.5 VDC (B and N connections)</p> <p>When the operating voltage drops below 9VDC, the lamps will begin to flash and gates will descend.</p>
Maximum Voltage to Crossing Control Inputs:	Nominal 12 VDC, maximum 20.0 VDC
Operating Current (not including Maint. Call lamp):	<p>20 ampere unit = 750 ma maximum (crossing not activated)</p> <p>40 ampere unit = 850 ma maximum (crossing not activated)</p>
Maximum Lamp Current Capability:	<p>20 amperes per lamp output bank, A or B</p> <p>(This will normally accommodate two sets of flashers with front and back lights, and two crossing gates for a total of eight 25-watt lamps lit at any given time.)</p>
Isolation:	2000 VAC isolation built-in
Short Circuit Lamp, Gate & Bell Output Protection:	Built-in
Surge Protection:	Secondary surge protection built-in for all external I/O, external primary surge protection required
Power Indication:	LED illuminated when power is applied

### 1.4.1.5 Echelon® LAN Interface

Data Transfer Rate:	1.25 Mbps
Node Wiring:	For normal installations within the same signal case or bungalow, use stranded twisted pair, conductor size #22 AWG (0.3 mm <sup>2</sup> ) to #16 AWG (1.3 mm <sup>2</sup> ).
Node Topology:	Bus (direct daisychain), no stubs or drops.
Number of Nodes:	No more than 8 in any 16 meter (53 feet) length of transmission cable (contact Siemens Rail Automation technical support if more are required).
Message Format:	ATCS compatible, vital and non-vital messages



#### CAUTION

BECAUSE THE ECHELON® INTERFACE IS NOT SURGE PROTECTED, THE NETWORK CONNECTIONS MUST BE RESTRICTED TO EQUIPMENT CONTAINED INSIDE A PROTECTED ENCLOSURE.

### 1.4.1.6 SSCC III PLUS Operating Specifications

System Reaction Time:	Nominal 700 ms
Real-Time Clock:	Drift = 1.752 minutes per month maximum Clock operating period with loss of power = 3 days minimum, 4 days maximum
Internal Event Recorder:	Diagnostic tool with capacity for last 8 train moves. Event memory is retained for at least 2 days after power is lost.
Power-Up Time:	Nominal 20 seconds from system power-up to fully operational (Warning devices are activated during power up).
Flashing Lamps:	3-wire circuit (L1, N, L2) with continuous energy across L1/L2 for gate tip lamps.
Flash Rate:	Programmable 30 to 70 FPM (default = 50) in increments of 5 FPM.

Duty Cycle:	Nominal 50% each flashed lamp
Crossing Control/GP Inputs:	Application specific- For BASIC.MCF and BASICPLS.MCF, XR Inputs (2 through 7) selectively enabled/disabled, input 8 reserved for Gate Position input. Input 1 is always enabled.
Lamp Voltage Adjustment:	Far gate lamps programmable, with regulated set points from 9.0 to 15.0 volts in 0.1 increments (actual output voltage limited to 1.5 volts less than battery voltage). Adjustment resistors provided for voltage drop compensation on “Near Gate” output of lighting/surge panel(s).
Crossing Control Input Impedance:	1k ohm nominal
Crossing Control Input States:	Energized = 7.5 to 20 VDC Deenergized = 0 to 2.5 VDC
Gate Control Drive Current:	The vital gate output is rated at 10 amperes DC for 10 seconds and for 6 amperes DC continuous at 12 volts.
Gate Control Drive Voltage:	Nominal 12 VDC
Programmable Gate Delay Period:	Programmable 3 through 20 seconds in 1-second increments (Output A independent of Output B)
Bell Output:	Continuous upon activation Optional bell off during gate rising
Bell Output Voltage and Current:	Nominal 12 VDC, 2 amperes per output
Test Modes:	Static lamp test - selected lamps lit steady } 1 L1, 1 L2 (all units) Static lamp test - all lamps flashing } 2 L1, 2 L2 (40-A units only) Activate crossing Timed lamp test - automatically delayed start & timed to go off Repeated lamp test – timed lamp test repeated after twice the initial delay



### 1.4.1.7 SSCC III PLUS Test, Setup and Program Modes

User Display:	Liquid crystal display, two rows of 16 characters each, temperature sensor and microprocessor-controlled heater
Idle Screen:	Date and time display alternating with MCF filename/revision over the time display (after boot-up or menu timeout)
Menu Timeout:	After 90 seconds of push button inactivity, returns to idle screen while in all menu modes (except when in active test or while setting up lamp voltages)
Key Entry:	Next/Previous, Enter/Exit momentary switches
Security:	Password protection enable/disable in Program mode
Configuration:	Can be changed by the user from the front panel or via DT utility
Real-time Clock:	Date and time settable from front panel in Program mode, or via the DT utility. Daylight savings time can be enabled or disabled.

### 1.4.1.8 SSCC III PLUS Interfaces

Battery Input: Three pins for B terminal and three pins for N terminal



**WARNING**

#### WARNING

**WHEN WIRING BATTERY-POWER TO AN SSCC III PLUS, THE FOLLOWING IS REQUIRED:**

**TWO (2) 'B' WIRES AND TWO (2) 'N' WIRES TO A 20-AMP UNIT.**

**THREE (3) 'B' WIRES AND THREE (3) 'N' WIRES TO A 40-AMP UNIT.**

**INCORRECT POLARITY WILL RESULT IN SEVERE DAMAGE TO THE CONTROLLER UNIT.**

Vital Control Inputs: Eight pairs (+ and –) for crossing control, normally the eighth input is used as GP (Gate Position input + and –)

Non-vital I/O 1 –  
(Flash Sync):

One pin configured as non-vital output, or as Flash Sync input/output (default = non-vital output).

- Sourced output rated for 2 amperes DC at 12 volts.
- Input voltage range = 5V to 16.5V, 50 ma. maximum.
- This I/O is referenced to controller's negative battery

Non-vital Output 2 –  
(Maintenance Call): One pin to provide a negative return for a MAINT CALL lamp circuit, rated for 4 amperes DC at 12 volts (48 watts total, or two 18-watt lamps)

Outputs: Output A lamp outputs (1 L1 and 1 L2 - all units)  
Output B lamp outputs (2 L1 and 2 L2 - 40-ampere units only)  
Gate output +1GC/-1GC (and +2GC/-2GC for 40-ampere units)  
Bell output 1 BELL (2 BELL for 40-ampere units)

Echelon<sup>®</sup> LAN: Two pins (polarity is arbitrary)

## **1.4.2 Lighting Surge Panel (A91170-1, A91170-2, A91181-1, A91181-2) Specifications**

### **1.4.2.1 Lighting Surge Panel Mechanical Specifications**

Packaging: Black powder-coat metal panel

Mounting: Wall or backboard mount,  
23-inch rack mount (not available in 19-inch rack mount)

Weight: A91170-1, A91181-1 are 10.0 lb (4.5 kg) (approx.)  
A91170-2, A91181-2 are 9 lb - 2 oz (4.1kg) (approx.)

Depth: 3.56 in (9.04 cm) including AREMA binding posts

Height: 6.97 in (17.70 cm)

Width: 23.0 in (58.42 cm) overall including mounting tabs

### 1.4.2.2 Lighting Surge Panel I/O Interface

I/O Interface Type:	Standard AREMA binding posts													
Near/Far Gate														
Cable Compensation:	Adjustable resistors for Near Gate L1 and L2													
Test/Measurement:	Special insulated links with gold-plated nuts on all connections to the crossing for quick circuit isolation													
Surge Protection on:	<table> <tr> <td>L1 (lamp 1 output for A and B)</td> <td rowspan="3">} Near and Far Gates</td> </tr> <tr> <td>L2 (lamp 2 output for A and B)</td> </tr> <tr> <td>En (lamp common for A and B)</td> </tr> <tr> <td>GP (gate position input – A91170-1, A91181-1 panels only)</td> <td></td> </tr> <tr> <td>1 BELL, 2 BELL (bell outputs for A, B, C and D)</td> <td></td> </tr> <tr> <td>1GC, 2GC (gate controls for A, B, C and D)</td> <td></td> </tr> <tr> <td>B (battery + input)</td> <td rowspan="2">} A91170-1, A91181-1 only</td> </tr> <tr> <td>N (battery return)</td> </tr> </table>	L1 (lamp 1 output for A and B)	} Near and Far Gates	L2 (lamp 2 output for A and B)	En (lamp common for A and B)	GP (gate position input – A91170-1, A91181-1 panels only)		1 BELL, 2 BELL (bell outputs for A, B, C and D)		1GC, 2GC (gate controls for A, B, C and D)		B (battery + input)	} A91170-1, A91181-1 only	N (battery return)
L1 (lamp 1 output for A and B)	} Near and Far Gates													
L2 (lamp 2 output for A and B)														
En (lamp common for A and B)														
GP (gate position input – A91170-1, A91181-1 panels only)														
1 BELL, 2 BELL (bell outputs for A, B, C and D)														
1GC, 2GC (gate controls for A, B, C and D)														
B (battery + input)	} A91170-1, A91181-1 only													
N (battery return)														

## 1.5 ORDERING INFORMATION

### 1.5.1 SSCC III PLUS 40-Ampere Unit, A91190

The part number breakdown for the SSCC III PLUS 40-ampere unit is:

#### 9000-91190-X1XX

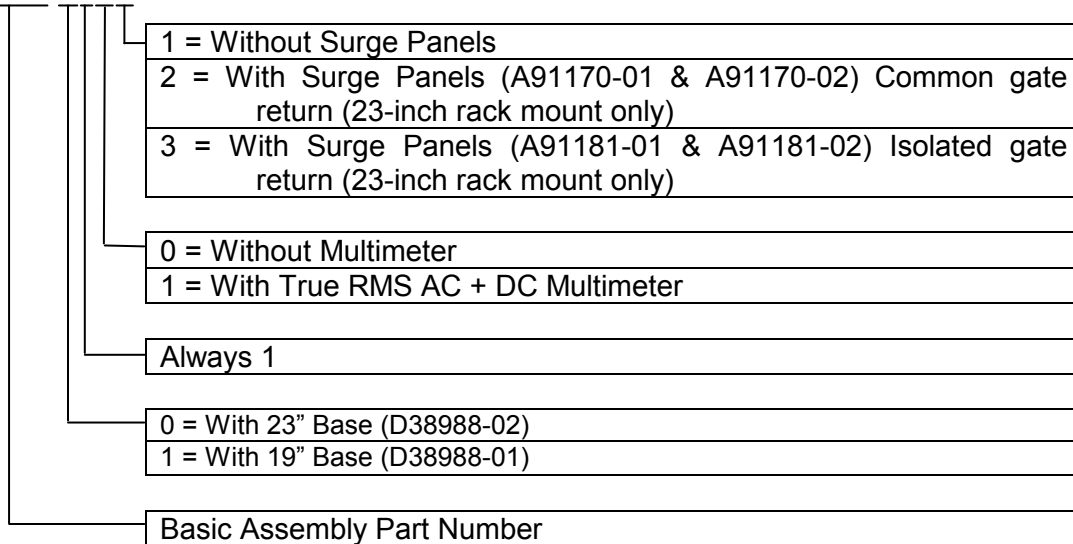

### 1.5.2 SSCC III PLUS 20-Ampere Unit, A91195

The part number breakdown for the SSCC III PLUS 20-ampere unit is:

#### 9000-91195-X1XX

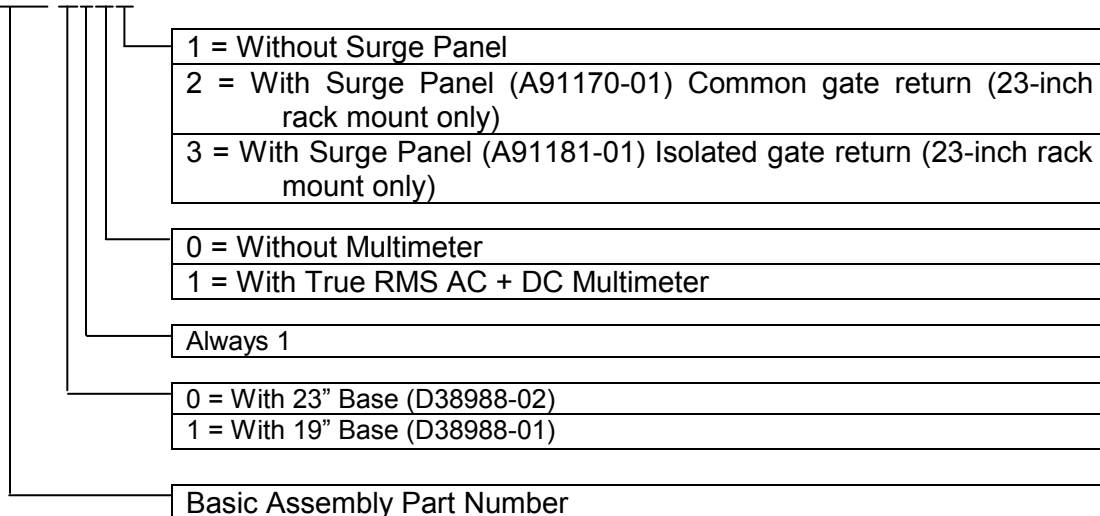

### 1.5.3 Lighting Surge Panels

Lighting Surge Panels can be ordered with the crossing controller unit, or they can be ordered separately.

To order Lighting Surge Panels separately, refer to the table below:

Part Number	Gate Control	Description
9000-91170-1	Common Return	Output A Lighting Surge Panel with battery surge protection (used with A91190 and A91195 units)
9000-91170-2		Output B Lighting Surge Panel (used with A91190 unit only)
9000-91181-1	Isolated Gate	Output A Lighting Surge Panel with battery surge protection (used with A91190 and A91195 units)
9000-91181-2		Output B Lighting Surge Panel (used with A91190 unit only)

### 1.5.4 Mating Connectors

Mating I/O connectors are shipped with each SSCC III Plus unit, but can also be ordered separately. The mating serial interface connector and cable is customer-supplied (DB-9 male). To order mating I/O connectors, specify the following Siemens part numbers:

Part Number	Connector Position On SSCC III Plus Front Panel Where Used	Contact type
Z715-09151-0000	J1, J2 and J6	Screw-down
Z715-09027-0006	J4	Cage Clamp
Z715-09027-0012	J3	Cage Clamp

This page intentionally left blank

## SECTION 2 INSTALLATION

### 2.1 GENERAL

The guidelines discussed in the following paragraphs should be observed during the installation of an SSCC III PLUS system and related equipment.

### 2.2 PHYSICAL INSTALLATION

The physical installation for the SSCC III PLUS system consists of securely mounting the unit and lighting surge panels, plus installing the interface connections. Following installation, refer to Section 5 for application programming, and refer to Section 6 for lamp voltage adjustment, testing, lamp aiming, and system verification.

#### 2.2.1 Mounting The SSCC III PLUS System

The SSCC III PLUS is designed to be mounted on a backboard or other flat surface. The crossing controller units are also available in widths for mounting in 19-inch or 23-inch racks (refer to figures 2-1 and 2-2 for mounting dimensions). The interconnections, the maintainers/installers interface, and the LED indicators are accessible from the front of the system. Make certain that the SSCC III PLUS case is grounded (through mounting hardware or other means).



#### CAUTION

ENSURE THAT THE SSCC III PLUS CASE IS ADEQUATELY GROUNDED BEFORE APPLYING POWER TO THE SYSTEM. REFER TO FIGURES 10-1 THROUGH 10-6 FOR TYPICAL GROUNDING.

The Lighting Surge Panels can be mounted directly in a 23-inch rack or on a backboard or other flat surface (refer to figure 2-3 for mounting dimensions).



#### CAUTION

SURGE PROTECTION FOR THE SSCC III PLUS AND ITS INPUT AND OUTPUT LINES IS PROVIDED BY LIGHTING SURGE PANELS, PART NUMBER A91170 OR A91181, BY THE SURGE PANELS INCLUDED IN A FARADAY SHIELDED BUNGALOW, OR BY EQUIVALENT SURGE PROTECTION AS SHOWN IN FIGURES 10-1 THROUGH 10-6.

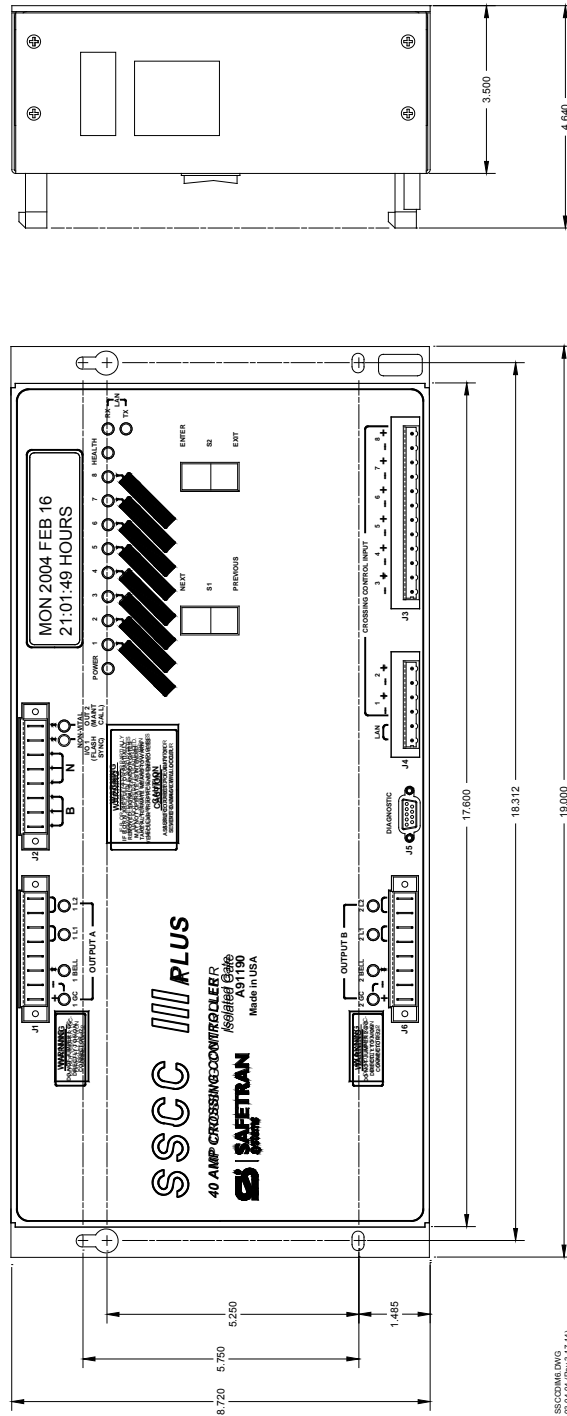

Figure 2-1. SSCC III PLUS Mounting Dimensions For 19-Inch Rack (Typical for A91990, A91195)



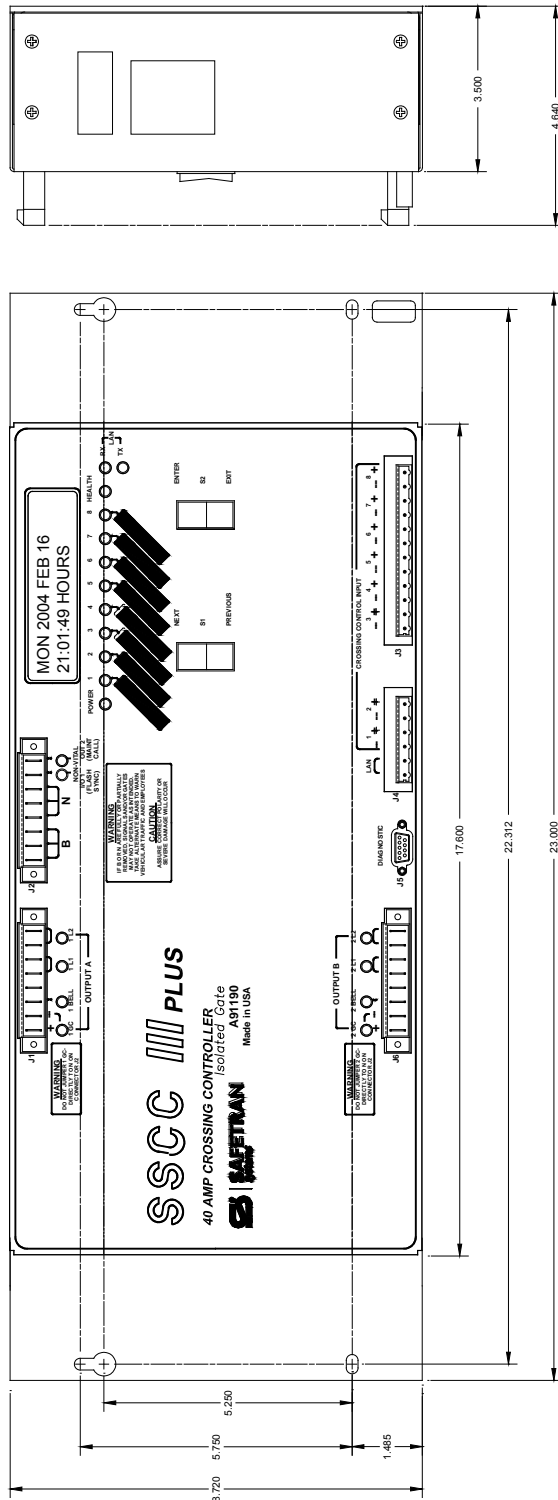
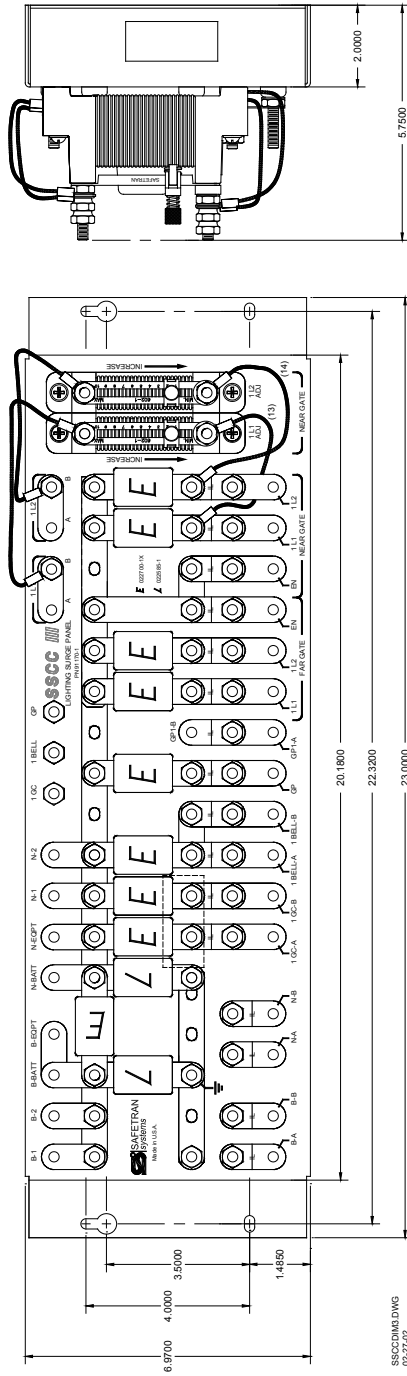
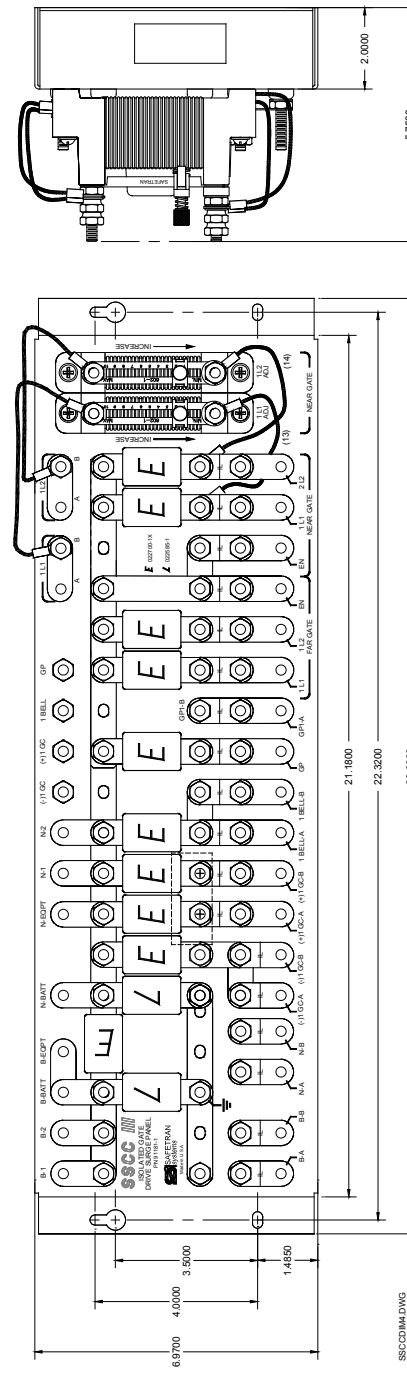

Figure 2-2. SSC III PLUS Mounting Dimensions For 23-Inch Rack (Typical for A91990, A91195)

**A91170**



**A91181**



**Figure 2-3. SSCC III PLUS Surge Panel Mounting Dimensions (Typical for -1 And -2 Versions)**

## 2.2.2 Wiring Harness

The wiring harness for the SSCC III PLUS includes connections to the power source and to all I/O. The SSCC III PLUS front panel connectors accommodate all external connections and interconnecting wiring to the lighting/surge panel(s), which in turn provide connections to the crossing. Wiring is in accordance with railroad schematics. Siemens does not provide the wiring harness.

**NOTE**

**NOTE**

For a BASIC MCF crossing application without gates, disable the GP input to the SSCC III PLUS by connecting the 8+ (GP+) input to the battery B terminal, and connecting the 8- (GP-) input to the battery N terminal.

### 2.2.2.1 Mating Connectors

The SSCC III PLUS unit is shipped with the necessary mating connectors for the I/O connections as determined by the configuration specified.

**⚠ WARNING**

**WARNING**

**ENSURE THAT ALL SSCC III PLUS FRONT PANEL MATING CONNECTORS ARE IN THE PROPER POSITION, WELL-SEATED AND SECURELY FASTENED DOWN.**

### 2.2.2.2 Wire Size And Type

Recommended wire sizes for an SSCC III PLUS system are as indicated in table 2-1. Maintain wire runs as short as possible.

**Table 2-1. Recommended SSCC III PLUS Wire Sizes**

SSCC III PLUS System Wiring	Recommended Wire Size And Quantity
Power to B input (SSCC III PLUS unit)	Two 10AWG (20-ampere unit) Three 10AWG (40-ampere unit)
Power to N input (SSCC III PLUS unit)	Two 10AWG (20-ampere unit) Three 10AWG (40-ampere unit)
Battery wiring to Lighting/Surge Panel(s) B and N	6AWG
Lamp outputs, gate outputs, and bell outputs (to lighting surge panels)	10AWG for each output
Underground wires from Lighting/Surge Panel(s) to lamps, bells, and gate motors	6AWG

**Table 2-1 Concluded**

SSCC III PLUS System Wiring	Recommended Wire Size And Quantity
Vital Inputs (crossing control, GP)	12AWG to 18AWG
Maintenance Call output	10AWG to 18AWG
Echelon® LAN	16AWG to 22AWG



**WARNING**

**WHEN WIRING BATTERY-POWER TO AN SSCC III PLUS, THE FOLLOWING IS REQUIRED:**

**TWO (2) 'B' WIRES AND TWO (2) 'N' WIRES TO A 20-AMP UNIT.  
THREE (3) 'B' WIRES AND THREE (3) 'N' WIRES TO A 40-AMP UNIT.**

**INCORRECT POLARITY WILL RESULT IN SEVERE DAMAGE TO THE CONTROLLER UNIT.**



**WARNING**

**IF B OR N ARE FULLY OR PARTIALLY REMOVED, SIGNALS AND/OR GATES MAY NOT OPERATE AS INTENDED. TAKE ALTERNATE MEANS TO WARN PEDESTRIANS, VEHICULAR TRAFFIC AND EMPLOYEES.**



**WARNING**

**BELL(S) MUST BE DRIVEN FROM SSCC III PLUS BELL OUTPUT(S) (1 BELL, 2 BELL) ONLY.**

**DO NOT USE LAMP OUTPUTS TO DRIVE BELLS!**

Mating connectors are cage clamp type for signal connections, and screw-down type for heavy current-carrying connections. Stranded wire should be used for all type connectors.

**2.2.2.3 Wire Preparation**

Strip insulation from the end of the wire as indicated in the table below.

Mating Connector for:	Type of Connection	Strip Length
J1, J2, and J6	Screw-down	0.28" (7 mm)
J3 and J4	Cage clamp	0.32" – 0.35" (8 – 9 mm)

It is recommended that a stripping tool be used which allows the strip length to be set accurately. The addition of ferrules is not required.

#### 2.2.2.4 *Wire Insertion*

For screw-down type connectors, the stripped end of a wire should be inserted into the wire receptor of the connector until it stops, then the screw-down should be tightened (using the screwdriver provided) to a torque of 4.5 inch pounds (0.5 – 0.6 Nm).

For cage clamp type connectors, the stripped end of a wire should be inserted into the wire receptor after levering the cage clamp open. This is accomplished by pressing straight down with the recommended type of screwdriver in the rectangular slot in the connector next to the wire receptor (some connectors also have optional slots on the side). Care should be taken to ensure that the wire receptor is fully open before wire insertion.

The recommended screwdriver type is provided with each unit (flat bladed with a blade size of 0.10" wide, 0.020" thick (2.5mm x 0.5mm)).



#### CAUTION

USE THE CORRECT WIRE INSERTION TOOL TO PREVENT DAMAGE TO THE CONNECTOR.

After the stripped end of a wire is inserted into the wire receptor, hold the wire in place while removing the screwdriver to allow the wire receptor to close on the stripped end of the wire, securing it in place. All the wires are to be prepared in this fashion.

#### 2.2.2.5 *Strain Relief*

Sufficient slack should be allowed in the bundles feeding the SSCC III PLUS connectors to allow for easy disengagement. This facilitates removal and replacement of the SSCC III PLUS unit, if necessary.

#### 2.2.2.6 *Maximum Lamp Cable Lengths*

When installing the crossing controller system, the maximum allowable length for any single cable run (either single or double wire) used to connect the crossing lamps to lighting/surge panel(s) is determined by the total system current requirement, type of battery driving the lamps, and the wire gauge. If wire resistance is too high due to excessive length, the crossing lamps will not receive their full rated voltage. This condition will trigger errors of “Open Lamp Neutral Wire” detection.

The effective resistance of the wire can be reduced and the maximum wire length increased by using two wires of the same gauge in parallel (doubling) to the crossing lamps. Figure 2-4 illustrates a typical crossing profile and table 2-2 lists the maximum recommended cable lengths (for the longest cable or cable pair) based upon load current and battery available.

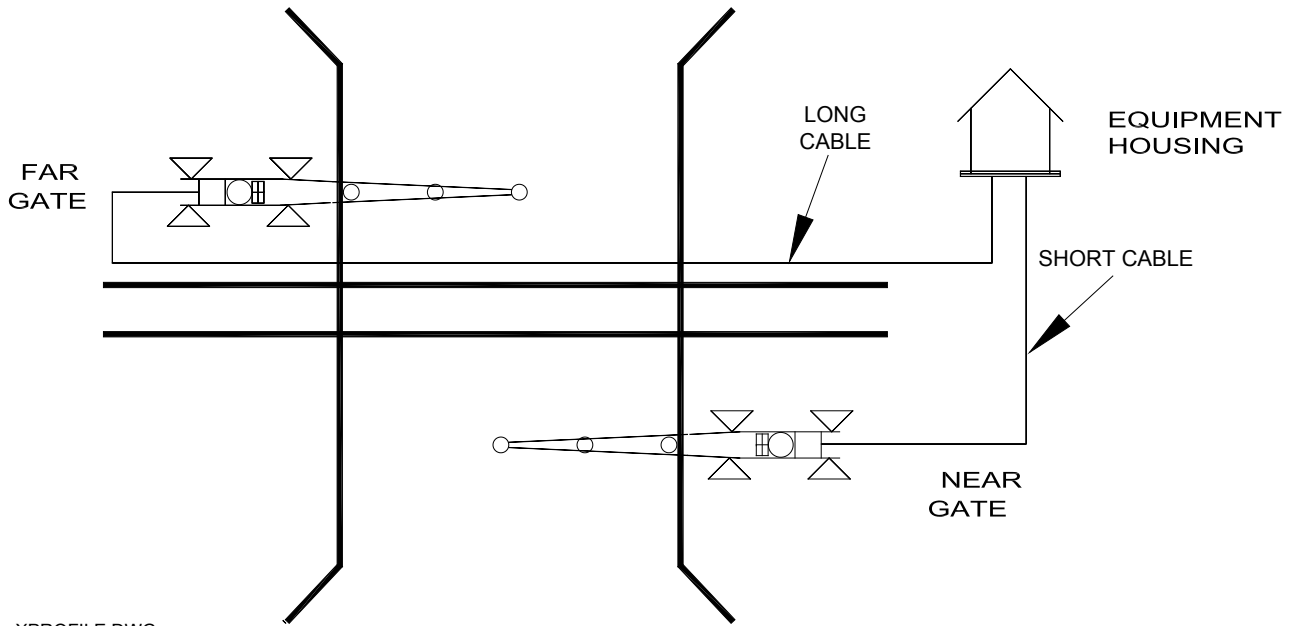

XPROFILE.DWG  
10-17-02

**Figure 2-4. Typical Crossing Profile**

**Table 2-2. Maximum Recommended Lengths For Crossing Lamp Cables[1]**

Cable Size	LOAD CURRENT									
	5.0 Amp		7.5 Amp				10.0 Amp			
	Battery/Cells <sup>[2]</sup>		Battery/Cells <sup>[2]</sup>				Battery/Cells <sup>[2]</sup>			
	L-6	N-9	L-6	L-7	N-10	N-11	L-6	L-7	N-10	N-11
#9AWG	225	175	117	260	200	260	88	213	150	213
#9AWG Double Leads N, L1, L2	450	350	234	520	400	520	176	426	300	426
#6AWG	450	350	234	500	400	500	175	375	300	375
#6AWG Double Leads N, L1, L2	900	700	469	1000	800	1000	350	750	600	750

[1] Cable lengths are given in feet.

[2] L = lead-acid, N = Nickel-cadmium. The number after the letter represents the number of cells.

Figure 2-5 illustrates a simplified diagram of typical cable wiring for driving crossing lamps.

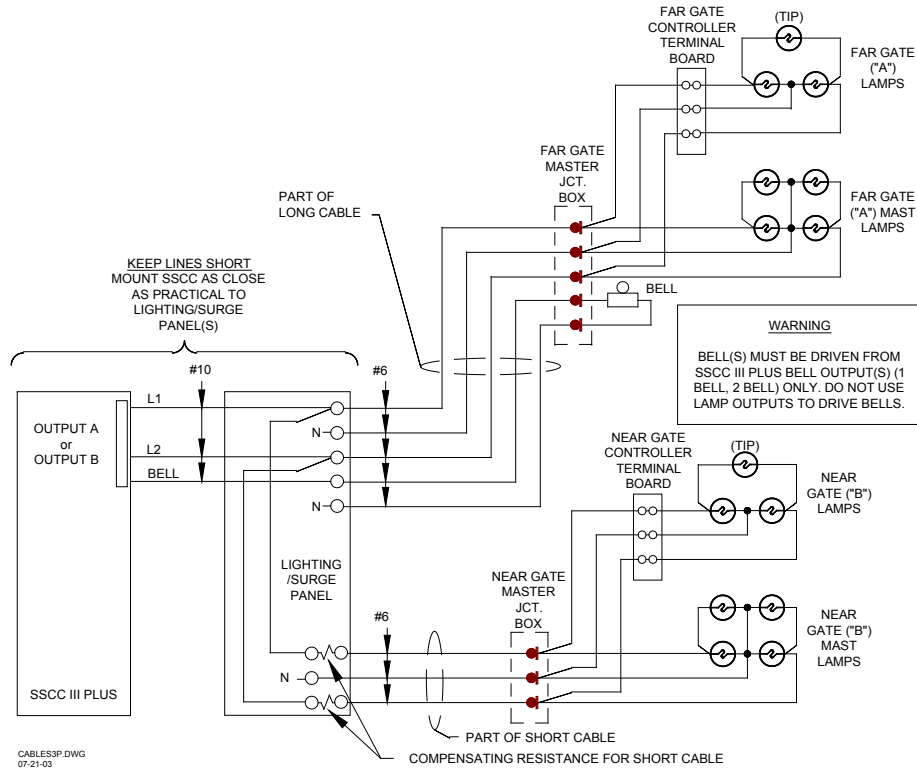

**Figure 2-5. Typical Lamp And Bell Cables**

Load current for systems requiring 5.0, 7.5, and 10 amps per cable is based upon 9.5 volts supplied to the lamps. Systems requiring 5 amperes normally consist of flashers only. Systems requiring 7.5 amperes normally consist of eight 18-watt lamps (4 on at a time) while systems requiring 10 amperes consist of eight 25-watt (4 on at a time) or ten 18-watt lamps (5 on at a time).

Batteries are lead-acid types with 6 or 7 cells or nickel-cadmium with 9, 10, or 11 cells. Recommended cable sizes are for number 6 AWG.

**2.2.2.7 Connecting Underground Wiring To Lighting/Surge Panels**

Conventional AREMA binding post mounting hardware is normally used for connecting underground wiring to the lighting/surge panel and from the lighting/surge panel to the crossing controller.

To provide for easy Megger checking of the underground wiring via the AREMA binding posts on the lighting/surge panel, insulated testing links and gold nuts are installed instead of the standard link hardware. The insulated testing link contains an integral insulating washer. The gold nut has a recess for the insulator, and provides for excellent conductivity from the terminal to the surface of the link. This special hardware makes it possible to open the link for testing simply by backing off the jam nut and the gold nut a few turns until contact with the link is lost. When the gold nut

and jam nut are tightened, the link functions in the normal manner. To ensure that the gold nut does not loosen, tighten a jam nut (not gold) on top of the gold nut (refer to figure 2-6).

When connecting underground wiring to terminals equipped with insulated links, the hardware should be installed as illustrated in figure 2-6 to ensure that the links remain parallel with the front panel surface and do not bind or become distorted when tightened.

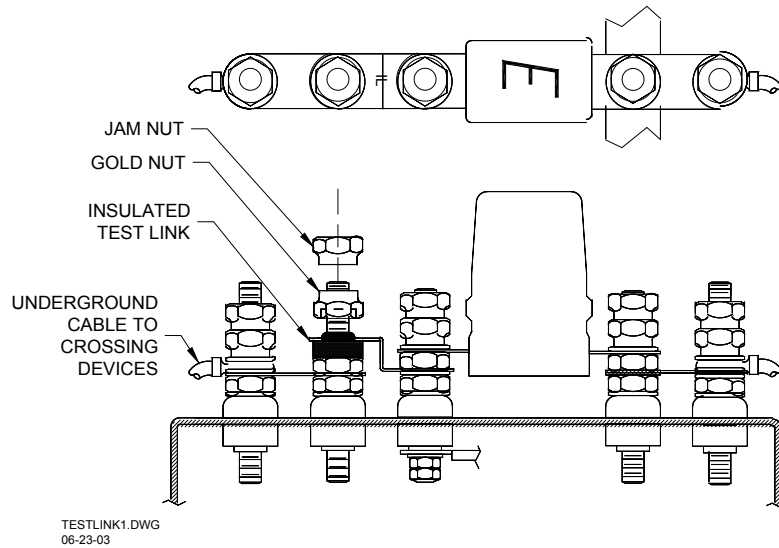

**Figure 2-6. Insulated Testing Link (shown in open position)**

### 2.2.3 Lighting/Surge Panels

Surge protection for the SSCC III PLUS system is provided by the lighting/surge panels. The surge panels contain the correct configuration of arresters and equalizers for the specific applications (refer to table 2-3 for a list of part numbers for surge panels).

**Table 2-3. Lighting Surge Panels**

Part Number	Gate Control	Description
A91170-1	Common Return	For Output A (used with A91190 and A91195 units)
A91170-2		For Output B (used with A91190 unit only)
A91181-1	Isolated Gate	For Output A (used with A91190 and A91195 units)
A91181-2		For Output B (used with A91190 unit only)

Surge protection for the battery circuits and the GP circuit as well as for the common interfaces to the crossing equipment is provided on the dash-one versions (refer to table 2-3). The A91181-1 panel is used with the 20-amp SSCC III PLUS unit (A91195), while an A91181-1 and an A91181-2 panel are generally required with the 40-amp unit (A91190). The A91170-1 panel is used with the 20-amp SSCC III PLUS unit (A91195), while an A91170-1 and an A91170-2 panel are required with the 40-amp unit (A91190) when common gate return is required.



The panel assemblies are designed for installation on the wayside enclosure accessory mounting board. The panels provide the interface between the external crossing gates, bells, and lamp circuit wiring and the crossing controller. Each panel is equipped with standard AREMA binding posts which accommodate connections to the battery lightning arresters and the battery, bells, gate, and lamp circuit equalizers.

Also included are two lamp-adjusting resistors, which are used as voltage adjustment for the “NEAR GATE” outputs. These resistors are used in combination with the microprocessor-controlled lamp outputs to compensate for any difference in voltage drops between the “NEAR GATE” and “FAR GATE” outputs due to different cable lengths.

#### 2.2.4 SSCC III PLUS DC Power Connections



##### CAUTION

DO NOT CONNECT POWER TO THE SSCC UNTIL COMPLYING WITH SECTION 2.3. FAILURE TO INITIALLY “POWER UP” IN THE PROPER SEQUENCE MAY PREVENT SHORT-CIRCUIT PROTECTION FROM DETECTING WIRING ERRORS AND DAMAGE THE UNIT.

The SSCC III PLUS is designed to operate directly from the signal operating battery. Typically, these batteries have voltages ranging between 12 volts and 16.5 volts. The SSCC III PLUS can maintain constant lamp output voltage, provided the battery voltage remains 1.5 volts higher than the programmed lamp output.

The battery circuit supplying the SSCC III PLUS should have primary surge protection, arresters, and equalizers, located as close as possible to the battery (refer to Section 10, figures 10-1 through 10-6). The SSCC III PLUS system power is also protected by internal secondary protection. The arresters and equalizers provided on Surge Panel, (part numbers A91170-1 and A91181-1), protect against surges coming into the signal house from the warning device cables.



##### WARNING

OBSERVE CORRECT POLARITY WHEN CONNECTING BATTERY TO THE SSCC III PLUS B AND N CONTACTS ON FRONT-PANEL CONNECTOR J2.



##### WARNING

INCORRECT POLARITY WILL RESULT IN SEVERE DAMAGE TO THE CONTROLLER UNIT.

Positive and negative battery are connected to the B and N screw-down fasteners on the J2 connector. Refer to Section 1, table 1-2, for connector pin assignments. Insulated 10 AWG stranded wire is recommended for power circuits. It is recommended that three (3) 'B' wires and three (3) 'N' wires be connected to the J2 connector on 40-Amp units. It is recommended that two (2) 'B' wires and two (2) 'N' wires be connected to the J2 connector on 20-Amp units. For typical system wiring, refer to the application drawings in Section 10.

When a common return gate control circuit is used, the negative wire connected to GC- must be connected directly to the negative gate circuit on the surge panel as shown in figure 1-8.

**WARNING**

**DO NOT CONNECT THE WIRES FROM 1GC- OR 2GC- DIRECTLY TO THE N TERMINAL ON THE J2 CONNECTOR. DOING SO MAY RESULT IN THE GATES NOT OPERATING AS INTENDED IN THE EVENT NEGATIVE POWER IS REMOVED FROM THE WIRES LEADING TO THE J2 CONNECTOR.**

### 2.2.5 Non-Vital I/O 1 (Flash Sync) Connection

Pin 7 of J2 is a non-vital Input/Output commonly used as a Lamp Flash Sync Connection. To synchronize lamp outputs on multiple controllers so that the left and right lamps flash in unison, connect pin 7 on J2 of each controller together. If separate batteries are used to supply power to the controllers, the negative sides of the batteries must also be connected to complete the external flash sync circuits (refer to figure 2-7). If total battery isolation is required, a fast acting non-vital relay controlled by the master controller can be used to synchronize the slave controller by keying the slave controller's positive battery through its contact to pin 7.

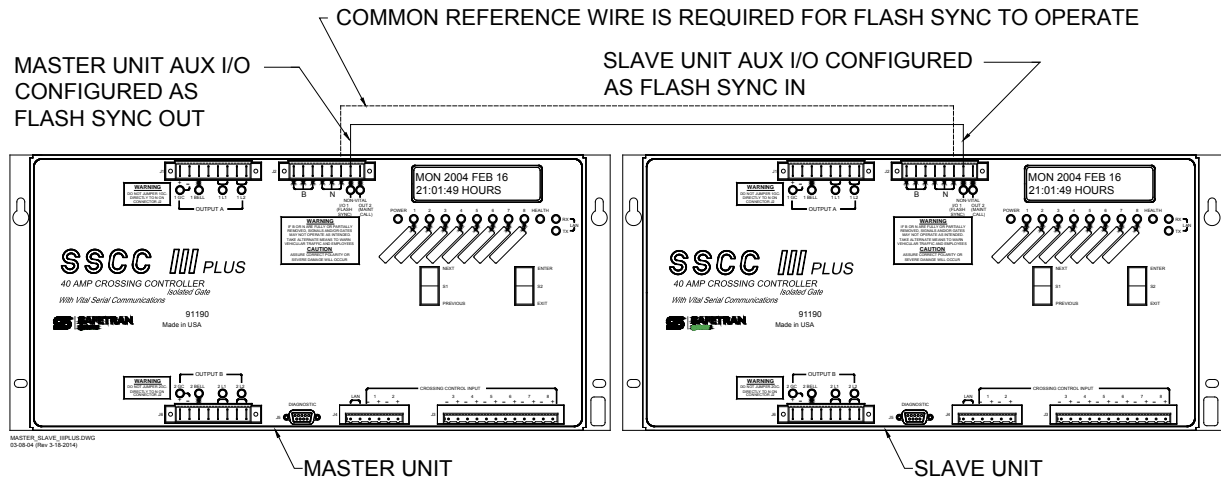

**Figure 2-7. Flash sync control and reference**

- NOTE**

GCP4000 Chassis have Isolated Flash Sync connections. Observe polarity when connecting GCP4000 Flash Sync connections to SSCC III Plus controllers.
- NOTE**

One controller must be configured for Flash Sync Out, with the other controller(s) configured for Flash Sync In. Refer to section 4.2.2.5 for configuring Aux I/O.
- NOTE**

All controllers must be programmed with the same flash rate in order for Flash Sync to operate properly. Refer to section 5.2.1.2 for programming controllers.

**2.2.6 Traffic Signal Preempt Relay Connections**

In many applications, the SSCC III Plus is capable of driving a traffic signal preemption relay. An example of the connections is shown in figure 2-8.

INSTALLATION

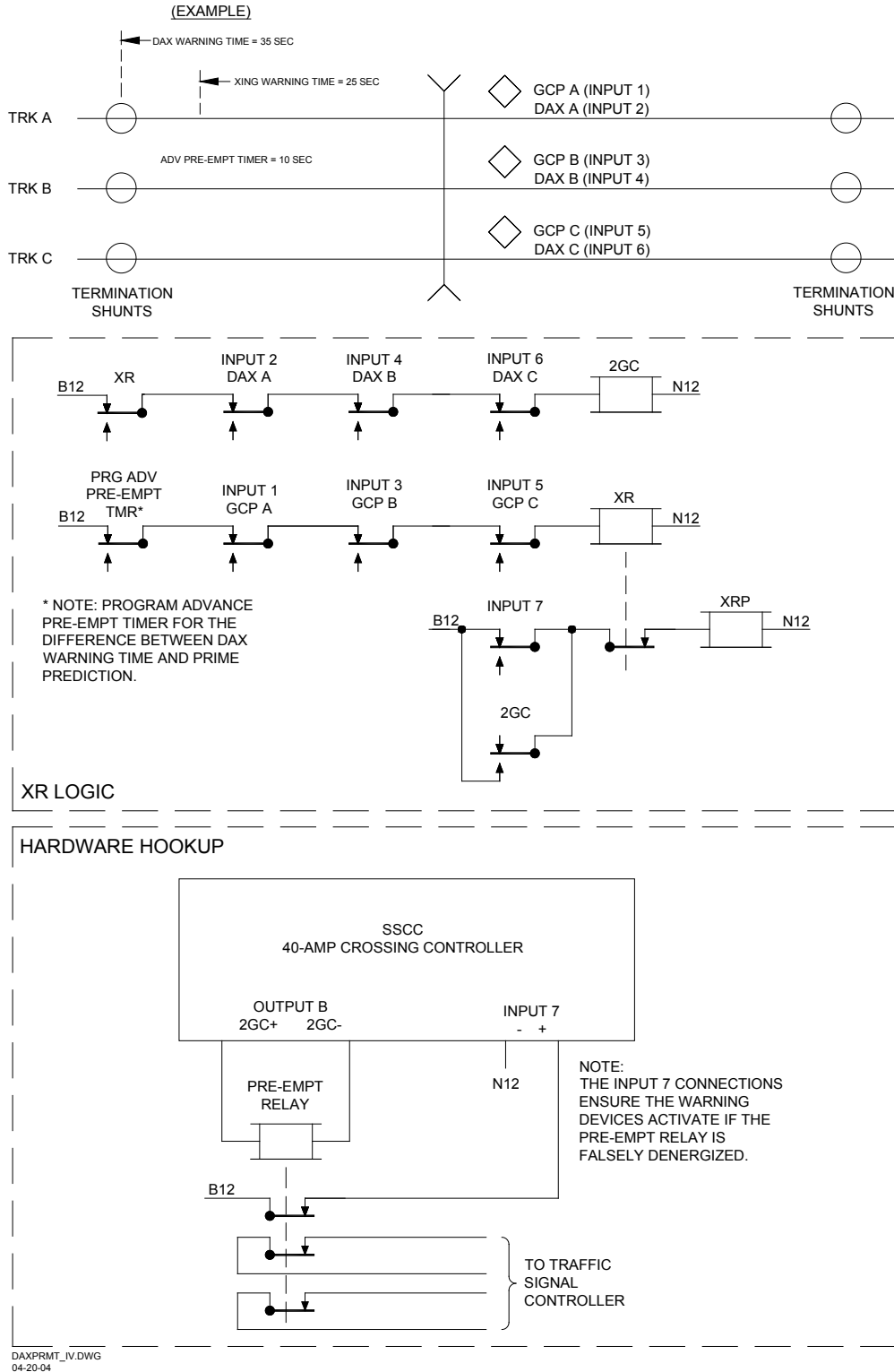

**Figure 2-8. Traffic Signal Preemption Relay Connections**

## 2.2.7 Non-vital ATCS Communication Connections

SSCC III PLUS units can communicate with other equipment via a twisted pair Echelon® LAN interface. Data on the LAN is transferred by using non-vital ATCS messages. The interface operates at a data rate of 1.25 Mbps and messages are sent in data packet format.

Table 2-4 lists and describes the pinouts for the for the J4 connector, which includes the Echelon® LAN interface.

**Table 2-4. Echelon® & Input Connector Pinouts (J4)**

Pin #	Signal Name	Description
1	ECH 0	Echelon® twisted pair LAN conductor (polarity is arbitrary)
2	ECH 1	Echelon® twisted pair LAN conductor (polarity is arbitrary)
3	Input 1 -	Crossing Control Input 1 negative lead
4	Input 1 +	Crossing Control Input 1 positive lead
5	Input 2 -	Crossing Control Input 2 negative lead
6	Input 2 +	Crossing Control Input 2 positive lead

### 2.2.7.1 Rules For Using Echelon® LAN

- Wire size is from #22AWG to #16AWG, stranded twisted pair.
- Each connection (node) must be wired in a daisy-chained bus configuration, no drops allowed (see figure 2-9).
- Maximum wiring length of LAN bus wiring is 53 feet (16m) within a signal case or bungalow, but wiring should be kept as short as practical.
- A maximum of 8 connection (nodes) is recommended. If additional connections are required, contact Siemens Technical Support for assistance.

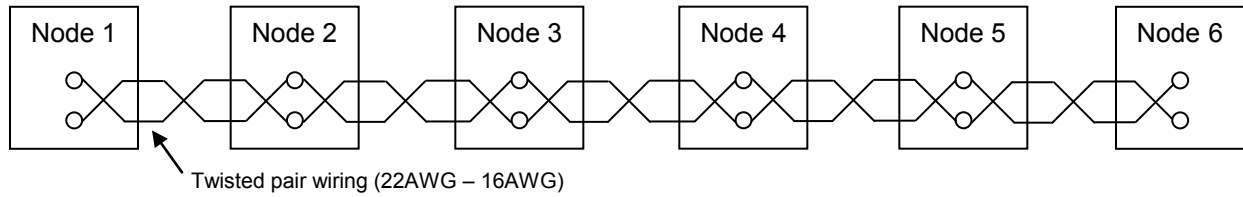

**CORRECT BUS WIRING**

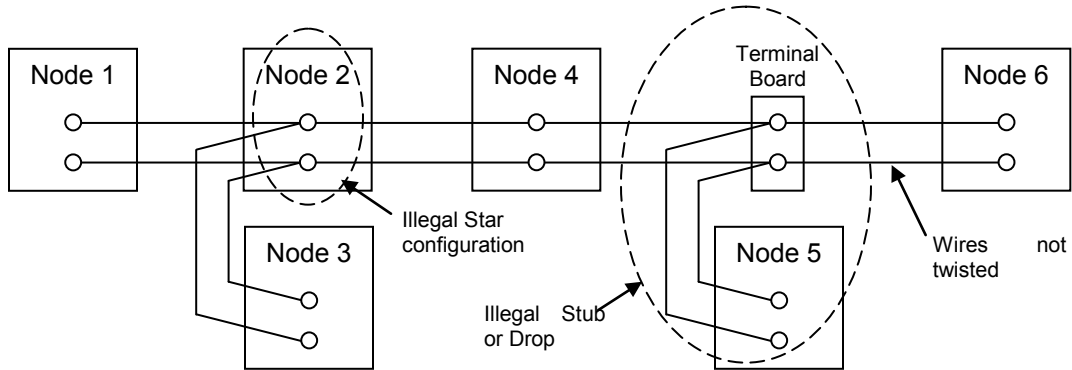

**EXAMPLES OF INCORRECT WIRING**

**Figure 2-9. LAN Bus Wiring**



**CAUTION**

BECAUSE THE ECHELON<sup>®</sup> INTERFACE IS NOT SURGE PROTECTED, NETWORK CONNECTIONS MUST BE RESTRICTED TO THE EQUIPMENT CONTAINED INSIDE A SIGNAL CASE OR BUNGALOW.



**NOTE**

For additional information concerning the Echelon<sup>®</sup> LAN, contact Siemens Technical Support.

**2.3 POWER UP AND INITIALIZATION**

The SSCC III Plus is equipped with active short circuit protection on its gate control, bell, and lamp outputs. To prevent initial wiring errors from damaging the controller the following sequence should be followed:

1. After the SSCC III PLUS is installed and all external wiring is completed, remove all plug connectors.

**WARNING**

**OBSERVE CORRECT POLARITY WHEN CONNECTING BATTERY TO THE SSCC III PLUS B AND N CONTACTS ON FRONT-PANEL CONNECTOR J2. REVERSED POLARITY WILL RESULT IN CONTROLLER DAMAGE.**

2. After verifying the battery polarity on the J2 plug, apply power to the unit by connecting the plug into the J2 connector.

When power is initially applied to the SSCC, the Power Up process begins. The Power Up and Initialization process takes approximately 20 seconds to complete. During this process, Vital Hardware and Software checks are performed to assure proper internal operation.

During the Power Up and initialization process, three display message screens appear in sequence. The first message to appear momentarily is the Power Up screen similar to figure 2-10.

SAFETLAN CROSSING  
CONTROLLER

**Figure 2-10. Power Up Screen**

The second message to appear momentarily on the display is the Software Version, similar to figure 2-11.

SOFTWARE VERSION  
9V546-A01.H

**Figure 2-11. Software Version Message**

Following the Software Version screen, the Initialization screen momentarily appears, similar to the one in figure 2-12.

PERFORMING INIT.  
CONFIG. CHECKS

**Figure 2-12. Initialization Screen**

After completing the Power Up and Initialization process, the SSCC should become fully operational and display the idle screen (current time and date alternating with the unit's MCF and time), similar to that shown in figure 2-13. This is the normal screen that is generally displayed whenever the front panel programming switches (S1 and S2) have not been used in the last 90 seconds.

Supisl.mcf.a  
21:13:12 HOURS

MON 2004 FEB 10  
21:13:13 HOURS

**Figure 2-13. Typical Idle Screen**

The unit always returns to this display after 90 seconds of inactivity on the push buttons, except when in the "Setup Lamp Voltages" mode or when a test mode is selected.

3. After initial turn on, connect the J1 plug into the **OUTPUT A** J1 connector (and the J6 plug into the **OUTPUT B** J6 connector on 40 amp models). The warning devices should be activated.
4. Connect J3 plug into the **INPUT** J3 connector and connect J4 plug into the **INPUT** J4 connector.
5. After installation and turn on, proceed to Section 5 for programming and configuration of the SSCC III PLUS unit.



**WARNING**

**TAKE ADEQUATE PRECAUTIONS TO WARN PERSONNEL, PEDESTRIANS, TRAINS AND OTHER VEHICLES IN THE AREA UNTIL PROPER SYSTEM OPERATION HAS BEEN VERIFIED.**



**NOTE**

Refer to Section 4 for general information on the programming and configuration menu displays. . The warning devices will remain activated until the proper inputs are energized for MCF selected

### 2.3.1 Failure During Power Up and Initialization

If the Power Up and Initialization process fails due to a failed vital check, the unit will stay in the Power Up and Initialization process (gates remain down with lights flashing). This is indicated by the Power Up and Initialization screens re-appearing and the Idle screen not appearing. The unit must be replaced to correct the problem (refer to Section 7 for troubleshooting).



**WARNING**

**WHILE THE SSCC III PLUS IS REBOOTING, THE CROSSING GATES ARE DOWN WITH LAMPS FLASHING AND BELLS RINGING (REGARDLESS OF THE STATE OF THE VITAL CROSSING CONTROL INPUTS). TAKE ADEQUATE PRECAUTIONS TO WARN PERSONNEL, PEDESTRIANS, TRAINS AND OTHER VEHICLES IN THE AREA UNTIL PROPER SYSTEM OPERATION HAS BEEN VERIFIED.**



## SECTION 3

### SSCC III PLUS MODULE CONFIGURATION FILES (MCF)

#### 3.1 GENERAL

A major feature of the SSCC III PLUS system is the addition of on-board user-selectable Module Configuration Files (MCF). Every SSCC III PLUS unit is factory-programmed with a set of MCFs where each individual MCF produces a specialized application program. The SSCC III PLUS operates a crossing based on the specific MCF file selected. When selected, each MCF except BASIC modifies the internal configuration and logic of inputs 1 through 7 and also provides unique programming of the 2GC output of the 40-Amp SSCC III PLUS unit. These inputs and the 40-Amp 2GC output can be used for, but are not limited to, GCP and DAX inputs, PSO track circuits, directional stick circuits, wrap circuits, or traffic signal pre-emption relay check contact. An LED indicator is associated with each input. When the input is activated the LED is illuminated, and when the input is deactivated the LED is dark. The Two Track Directional Stick MCF (2TRKDSTK) use a flashing LED to indicate that the directional stick is bypassing an input in the XR circuit.

The 2GC output on the 40-amp unit can be used to control a normal gate control relay, an inverted gate control for exit gate mechanisms, or drive a relay for traffic signal pre-emption or active beacon on highway-railroad advance warning signs.

Due to differences in the applications, some programming steps and menu displays in the PROGRAM and CONFIGURE menus may differ, depending on the selected MCF. The proper MCF may be selected in the field at the time of installation without the need for a laptop computer by using the built-in menu system (refer to Section 5 for application programming).



**WARNING**

#### WARNING

**IT IS NECESSARY TO SELECT THE PROPER MCF FILE PRIOR TO PROGRAMMING ANY STEPS IN THE PROGRAM MENU AND THE MCF MUST CORRESPOND WITH THE CROSSING WIRING. FAILURE TO DO SO MAY CAUSE THE CROSSING NOT TO ACTIVATE.**

**IF THE SELECTED MCF IS CHANGED, ALL PARAMETERS NEED TO BE RE-ENTERED/ RECHECKED.**

### 3.2 MCF DESCRIPTIONS

**NOTE**

**NOTE**

Railroad-specific MCFs may be custom ordered. Contact Siemens Technical Support for more information.

For custom orders, not all of the available MCFs will be present in the crossing controller unit.

Each MCF has a unique MCF ID number that must be entered after the MCF is loaded or changed.

The available MCFs and their current MCF ID numbers are listed in table 3-1.

**Table 3-1. Available MCFs**

MCF	ID	Description
BASIC	130	Basic crossing activation application, where all detection inputs are logically ANDed together with optional LOS timers (same as SSCC IIIA).
BASICPLS	087	Same as basic application above plus additional functions that are available on all MCFs except BASIC, such as “Out Of Service” mode, traffic signal pre-emption output, optional second gate-control (normal, inverted for Exit gate control, or simultaneous or advance pre-emption where 2GC output drives a traffic pre-empt relay). In addition, this MCF supports active beacons on highway-railroad advance warning signs.
3TRK1WRP	682	Triple track, GCPs with single Wrap Circuit per track. Each Wrap Circuit and configurable input 7 have an optional LOS timer. Can be programmed for optional second gate-control output (see BASICPLS MCF). In addition, this MCF supports active beacons on highway-railroad advance warning signs.
2TRK2WRP	606	Double track, GCPs with double Wrap Circuit per track. Each Wrap Circuit and configurable input 7 have an optional LOS timer. Can be programmed for optional second gate-control output (see BASICPLS MCF). In addition, this MCF supports active beacons on highway-railroad advance warning signs.
2TRKDSTK	320	Directional Stick Logic, Double Track, (PSO, IPI, Style C), with Vital Stick Cancellation Timer. Optional LOS timers on each input. Can be programmed for optional second gate-control output (see BASICPLS MCF). In addition, this MCF supports active beacons on highway-railroad advance warning signs, and an optional test switch input for activating warning devices and releasing the directional stick.
SUPISL	285	Double Track, Supplemental Island – Double Track GCP and conventional island with a Supplemental Island (such as a wheel counter system). Supplemental Island logic requires both conventional and supplemental islands to be energized before island logic energizes. LOS timers on supplemental island input and configurable input. Can be programmed for optional second gate-control output (see BASICPLS MCF). In addition, this MCF supports active beacons on highway-railroad advance warning signs,

**Table 3-1 concluded**

MCF	ID	Description
3TRK2TRN	962	Second Train Coming logic on Triple Track with GCP. Input 7 has optional LOS timer. Can be programmed for optional second gate-control output (see BASICPLS MCF). In addition, this MCF supports active beacons on highway-railroad advance warning signs,
2TRK2TRN	065	Second Train Coming logic with Wrap Circuit on Double Track with GCP. Each Wrap Circuit and the configurable input 7 have an optional LOS timer. Can be programmed for optional second gate-control output (see BASICPLS MCF). In addition, this MCF supports active beacons on highway-railroad advance warning signs,
DAXPRMT	413	Traffic Signal Advance Pre-emption Control – Double Track GCP and DAX (Advance Pre-emption) outputs feed directly into SSCC III PLUS, and the second “Gate Control” output controls the Traffic Signal Pre-emption Relay. Not available on 20-Amp units.

**NOTE****NOTE**

The concept of XR relay and relay contacts in the following application MCF diagrams is a function of logic internal to the SSCC III PLUS, rather than a physical relay and relay contacts.

**NOTE****NOTE**

Active Beacons are one or more flashing yellow signal heads on a Highway-Railroad Advance Warning Sign mast that are used to provide supplemental emphasis to the advance warning sign while the highway-railroad grade crossing warning devices are activated. Active beacons may be installed by the highway agency when curves or hills restrict preview of a highway-railroad grade warning system. A BEACON DELAY TIMER may be used to keep the beacon activated a period of time after the warning devices deactivate. The purpose of the delay time is to provide time for traffic stopped at the crossing to resume speed before the active beacon is turned off. The delay time is determined by engineering study.

**3.2.1 BASIC MCF****3.2.1.1 BASIC MCF Description**

The BASIC MCF is used in a basic crossing application. The BASIC MCF file is identical to the SSCC IIIA file (basic crossing configuration) in both program and operation. The sub-menus under the main menu PROGRAM have not changed. This MCF permits the SSCC III PLUS to be an exact field replacement for a SSCC IIIA. Inputs 1 through 7 are logically ANDed together and have optional LOS timers.

### 3.2.1.2 BASIC MCF Operation

The crossing activates when any of the enabled SSCC III PLUS inputs 1 through 7 are de-energized (input #1 is always enabled). Thus, the XR is driven by inputs 1 through 7 in an “AND” array as shown in figure 3-1. Inputs 2 through 7 can be enabled or disabled by application programming. In this way, unused inputs can be disabled (refer to figure 3-1) without the need to apply battery voltage (+ and -) to unused inputs. If a test switch is not required, input 4 can be disabled in the Program menu (program enabled inputs 1 thru 3).

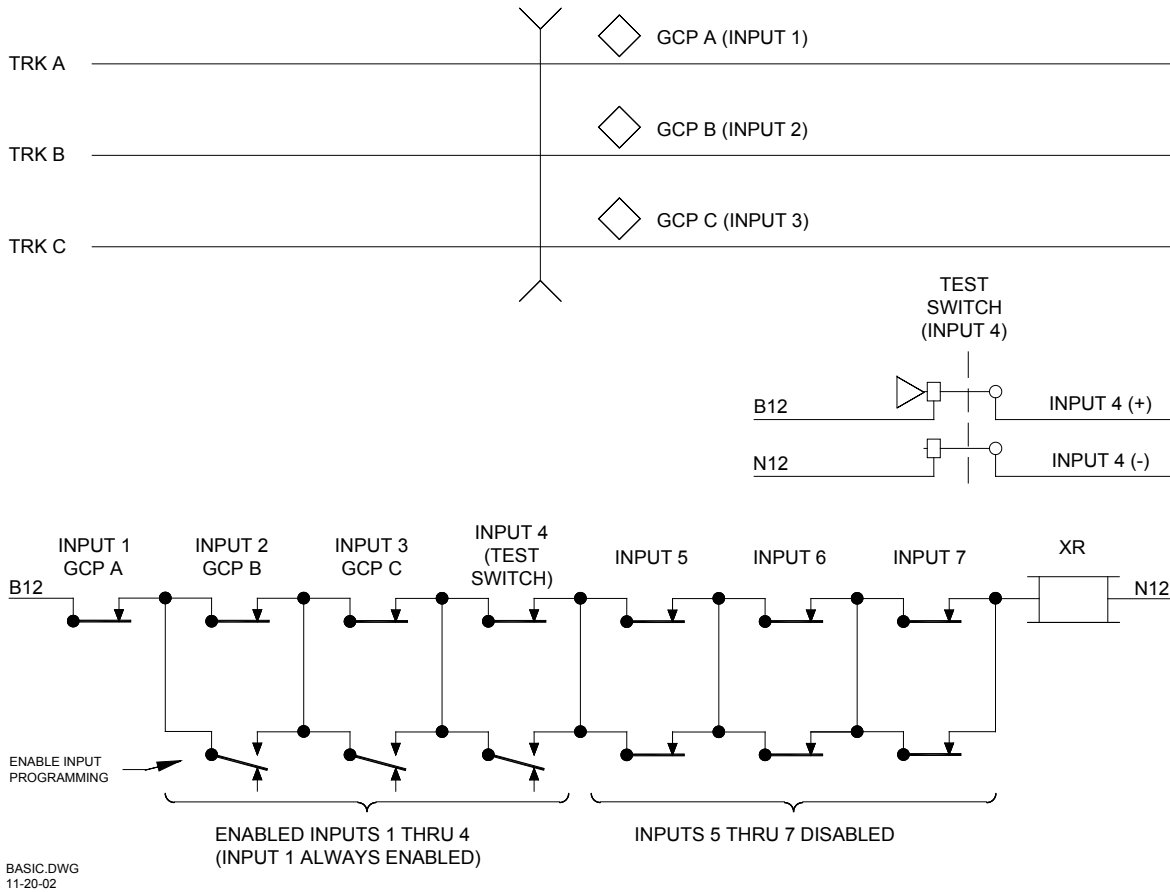

Figure 3-1. Typical XR Inputs for BASIC MCF

The BASIC MCF file has a maximum of 7 activation inputs that can be programmed for use. As a minimum, one input (input #1) must be used. For example, if only one input is used to control the SSCC III PLUS, then use input number 1 and set the ENABLED INPUTS to **1 THRU 1**. If two inputs are used, then use input numbers 1 and 2 and set the ENABLED INPUTS to **1 THRU 2** (the default = **1 THRU 7**).

### 3.2.1.3 BASIC MCF Physical Inputs

The inputs available on the BASIC MCF configuration are listed in table 3-2.

**Table 3-2. BASIC MCF Inputs**

Input #	Input Function	Optional LOS <sup>[1]</sup>	Notes
1	(not defined) <sup>[2]</sup>	Yes	Required (cannot be disabled)
2	(not defined) <sup>[2]</sup>	Yes	Disable in Program menu if not used
3	(not defined) <sup>[2]</sup>	Yes	Disable in Program menu if not used
4	(not defined) <sup>[2]</sup>	Yes	Disable in Program menu if not used
5	(not defined) <sup>[2]</sup>	Yes	Disable in Program menu if not used
6	(not defined) <sup>[2]</sup>	Yes	Disable in Program menu if not used
7	(not defined) <sup>[2]</sup>	Yes	Disable in Program menu if not used
8	GP – (Gate Position) <sup>[3]</sup>	No	Required (cannot be disabled)

[1] LOS = Loss-Of-Shunt timer.

[2] Although inputs 1 through 7 are “not defined” in this table, the most common application would be to connect to an MS/GCP crossing relay output. Inputs 1 through 7 are “Anded” together, thus de-energizing of any of these inputs will cause the crossing to activate.

[3] Input 8 is intended to be used as the Gate Position (GP) input. Gate wiring should be such that Input #8 is active when all the gates are in the “up” position. When any gate is not detected as “up”, this input becomes deenergized which causes the lamps to flash.

### 3.2.1.4 Optional Loss-Of-Shunt Timer

The BASIC MCF is equipped with an optional Loss-Of-Shunt timer for each of the seven configured XR inputs. The Loss-Of-Shunt time is the delay from the time the input energizes to when the logic considers the input valid. The LOS timer is settable using the CONFIGURE menu of the crossing controller, or using the DT utility. The range is 0 to 20 seconds (default = 0 second), and each enabled input will have an LOS timer in the CONFIGURE menu. If no LOS time is required, set the LOS time to zero (0).

#### **NOTE**

**NOTE**

Refer to Section 5, paragraph 5.2.1.3, *Using the CONFIGURE Menu*, for configuring Loss-Of-Shunt timer

### 3.2.2 BASICPLS MCF

#### 3.2.2.1 BASICPLS MCF Description

The BASICPLS (BASIC PLUS) MCF is similar to the BASIC MCF, but produces some changes in the PROGRAM menu. It provides for inputs 2-7 to be enabled or disabled individually (input #1 is always enabled). Inputs 1 through 6 are logically ANDed together and have optional LOS timers. Input #7 is a configurable input that can be used for crossing activation or for traffic pre-emption relay check contact. In addition, the 2GC output can be programmed for Normal operation, Inverted output for exit gate operation, Simultaneous Pre-emption and Advance Pre-emption where the 2GC output drives a traffic pre-empt relay, or Beacon, where 2GC controls an active beacon on a highway-railroad advance warning sign. Input #7 is a configurable input that can be used for crossing activation, or for traffic pre-emption relay health check. Refer to paragraph 3.3 for using 2GC Output / Input #7 (2GC/I7).

#### 3.2.2.2 BASICPLS MCF Operation

The crossing activates when any of the enabled SSCC III PLUS inputs 1 through 6 (1 through 7 when input 7 is configured as an activation input) are de-energized. Thus, XR is driven by the enabled activation inputs in an “AND” array as shown in figure 3-2. Inputs 2 through 7 can be enabled or disabled by application programming. In this way, unused inputs can be disabled (refer to figure 3-2) without the need to apply battery voltage (+ and -) to unused inputs. If a test switch is not required, input 4 can be disabled in the Program menu, or not configured for activation.

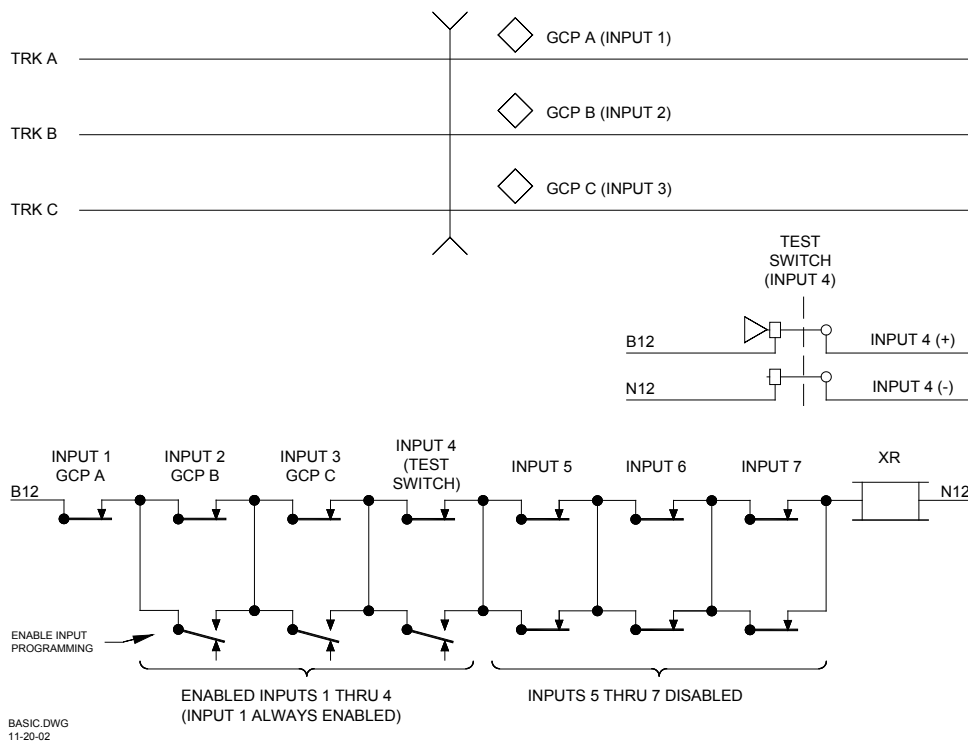

Figure 3-2. Typical XR Inputs for BASICPLS MCF

### 3.2.2.3 BASICPLS MCF Physical Inputs

The inputs available on the BASICPLS MCF configuration are listed in table 3-3.

**Table 3-3. BASICPLS MCF Inputs**

Input #	Input Function	Optional LOS <sup>[1]</sup>	Notes
1	(not defined) <sup>[2]</sup>	Yes	Required (cannot be disabled)
2	(not defined) <sup>[2]</sup>	Yes	Disable in Program menu if not used
3	(not defined) <sup>[2]</sup>	Yes	Disable in Program menu if not used
4	(not defined) <sup>[2]</sup>	Yes	Disable in Program menu if not used
5	(not defined) <sup>[2]</sup>	Yes	Disable in Program menu if not used
6	(not defined) <sup>[2]</sup>	Yes	Disable in Program menu if not used
7	Configurable <sup>[3]</sup>	Yes	Disable in Program menu if not used
8	GP – (Gate Position) <sup>[4]</sup>	No	Required if gates are used. If no gates are used, disable in Program menu.

[1] LOS = Loss-Of-Shunt timer.

[2] Although inputs 1 through 6 are “not defined” in this table, the most common application would be to connect to an MS/GCP crossing relay output. Inputs 1 through 6 are “Anded” together, thus de-energizing of any of these inputs will cause the crossing to activate.

[3] Input 7 is a configurable input (with LOS timer) except when in pre-empt mode. Refer to section 3.2..

[4] Input 8 is intended to be used as the Gate Position (GP) input. Gate wiring should be such that Input #8 is active when all gates are in the “up” position. When any gate is not detected as “up”, this input becomes deenergized which causes the lamps to flash. If the crossing does not use gates, the GP input must be disabled by setting “Gates Used” to “NO” in the Program menu.

### 3.2.2.4 Optional Loss-Of-Shunt Timer

The BASICPLS MCF file provides an optional Loss-Of-Shunt timer for each of the six configured XR inputs and input #7 (configurable). The Loss-Of-Shunt time is the delay from the time the input energizes to when the logic considers the input valid. The LOS timer is settable using the CONFIGURE menu of the crossing controller, or using the DT utility. The range is 0 to 20 seconds (default = 0 second), and each enabled input will have an LOS timer in the CONFIGURE menu. If no LOS time is required, set the LOS time to zero (0).

#### **NOTE**

#### **NOTE**

Refer to Section V, paragraph 5.2.1.3, *Using the CONFIGURE Menu*, for configuring LOS timer.

### 3.2.3 3TRK1WRP MCF

#### 3.2.3.1 3TRK1WRP MCF Description

The 3TRK1WRP MCF was designed for Triple Track GCPs with single Wraparound circuits for each track. This MCF utilizes inputs 1-6 for inputting up to 3 tracks with motion or prediction equipment for crossing controls and provides individual wrap inputs for each control input (Input 1 is OR'd with Input 2, etc.). It also provides a programmable Loss-Of-Shunt timer for each wrap input. In addition, the 2GC output can be programmed for Normal operation, Inverted output for exit gate operation, Simultaneous Pre-emption and Advance Pre-emption where the 2GC output drives a traffic pre-empt relay, or Beacon, where 2GC controls an active beacon on a highway-railroad advance warning sign. Input #7 is a configurable input that can be used for crossing activation, or for traffic pre-emption relay health check. Refer to paragraph 3.3 for using 2GC Output / Input #7 (2GC/I7).

#### 3.2.3.2 3TRK1WRP MCF Operation

The crossing activates when one or more GCP inputs (A, B, or C) and its associated wrap circuit both de-energize (refer to figure 3-3).

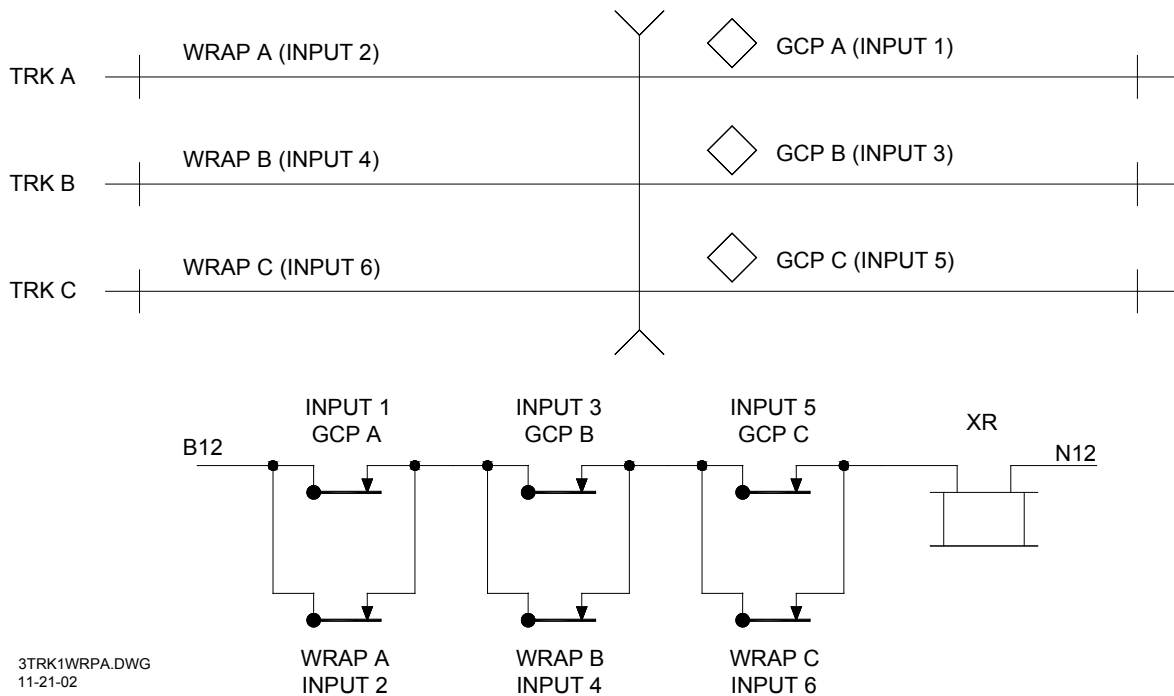

Figure 3-3. Typical XR Inputs for 3TRK1WRP MCF



### 3.2.3.3 3TRK1WRP MCF Physical Inputs

The inputs available on the 3TRK1WRP MCF are listed in table 3-4.

**Table 3-4. 3TRK1WRP MCF Inputs**

Input #	Input Function	Optional LOS <sup>[1]</sup>	Notes
1	GCP A	No	
2	Wrap A	Yes	
3	GCP B	No	Disable in Program menu if not used
4	Wrap B	Yes	
5	GCP C	No	Disable in Program menu if not used
6	Wrap C	Yes	
7	Configurable <sup>[2]</sup>	Yes	
8	GP – (Gate Position) <sup>[3]</sup>	No	Required if gates are used. If no gates are used, disable in Program menu.

[1] LOS = Loss-Of-Shunt timer.

[2] Input 7 is a configurable input (with LOS timer) except when in pre-empt mode. Refer to section 3.2..

[3] Input 8 is intended to be used as the Gate Position (GP) input. Gate wiring should be such that Input #8 is active when all the gates are in the “up” position. When any gate is not detected as “up”, this input becomes deenergized which causes the lamps to flash. If the crossing does not use gates, the GP input must be disabled by setting “Gates Used” to “NO” in the Program menu.

### 3.2.3.4 Optional Loss-Of-Shunt Timer

The 3TRK1WRP MCF file is equipped with an optional Loss-Of-Shunt timer for the three wrap circuits and Input #7 (configurable). The Loss-Of-Shunt time is the delay from the time the input energizes to when the logic considers the input valid. The LOS timer is settable using the CONFIGURE menu of the crossing controller, or using the DT utility. The range is 0 to 20 seconds (default = 0 second), and each wrap input will have an LOS timer in the CONFIGURE menu. In general, wrap inputs should have a minimum of 5 seconds of LOS time programmed.

#### **NOTE**

**NOTE**

Refer to Section 5, paragraph 5.2.1.3, *Using the CONFIGURE Menu*, for configuring Loss-Of-Shunt timer.

### 3.2.4 2TRK2WRP MCF

#### 3.2.4.1 2TRK2WRP MCF Description

The 2TRK2WRP MCF was designed for Double Track GCPs with 2 Wraparound circuits for each track. This MCF utilizes inputs 1-6 for inputting up to 2 tracks with motion or prediction equipment for crossing controls, and provides two series wrap inputs for each control input (Input 1 is OR'd with Input 2, etc.). It also provides a programmable Loss-Of-Shunt (LOS) timer for each wrap input. In addition, the 2GC output can be programmed for Normal operation, Inverted output for exit gate operation, Simultaneous Pre-emption and Advance Pre-emption where the 2GC output drives a traffic pre-empt relay, or Beacon, where 2GC controls an active beacon on a highway-railroad advance warning sign. Input #7 is a configurable input that can be used for crossing activation, or for traffic pre-emption relay health check. Refer to paragraph 3.3 for using 2GC Output / Input #7 (2GC/I7).

#### 3.2.4.2 2TRK2WRP MCF Operation

The crossing activates when one of the GCP inputs (A or B) and one of its associated wrap circuits deenergizes (figure 3-4).

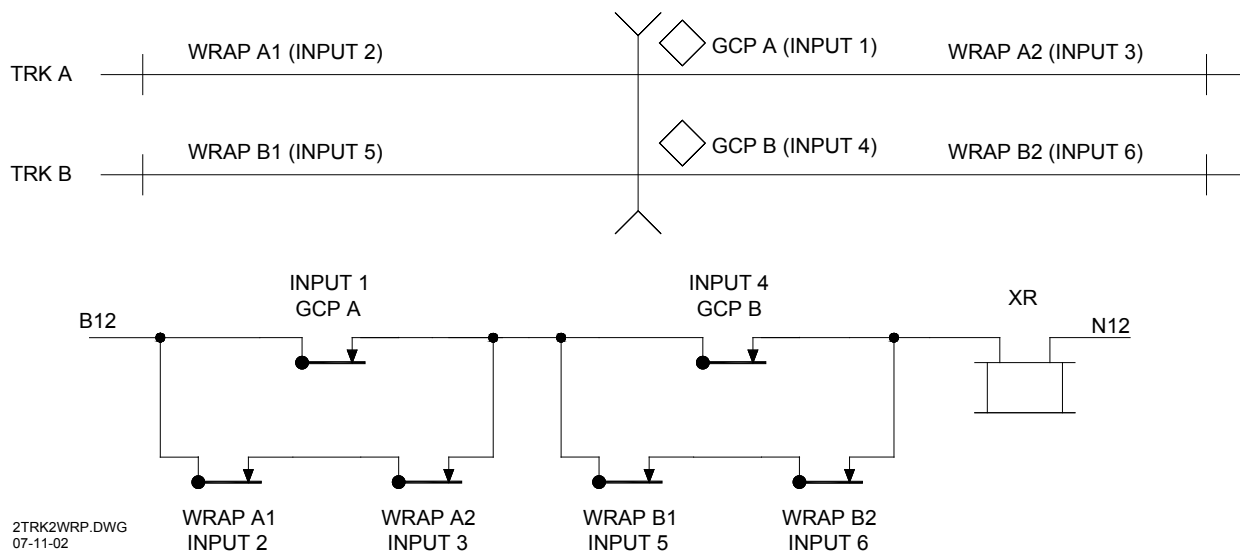

Figure 3-4. Typical XR Inputs for 2TRK2WRP MCF

### 3.2.4.3 2TRK2WRP MCF Physical Inputs

The inputs available on the 2TRK2WRP MCF configuration are listed in table 3-5.

**Table 3-5. 2TRK2WRP MCF Inputs**

Input	Input Function	Optional LOS <sup>[1]</sup>	Notes
1	GCP A	No	
2	Wrap A1	Yes	
3	Wrap A2	Yes	
4	GCP B	No	Disable in Program menu if not used
5	Wrap B1	Yes	
6	Wrap B2	Yes	
7	Configurable <sup>[2]</sup>	Yes	
8	GP (Gate Position) <sup>[3]</sup>	No	Required if gates are used, otherwise disable in Program menu.

[1] LOS = Loss-Of-Shunt timer.

[2] Input 7 is a configurable input (with LOS timer) except when in pre-empt mode. Refer to section 3.2...

[3] Input 8 is intended to be used as the Gate Position (GP) input. Gate wiring should be such that Input #8 is active when all the gates are in the "up" position. When any gate is not detected as "up", this input becomes deenergized which causes the lamps to flash. If the crossing does not use gates, the GP input must be disabled by setting "Gates Used" to "NO" in the Program menu.

### 3.2.4.4 Optional Loss-Of-Shunt Timer

The 2TRK2WRP MCF configuration file is equipped with an optional Loss-Of-Shunt timer for each of the wrap inputs and Input #7 (configurable). The Loss-Of-Shunt time is the delay from the time the input energizes to when the logic considers the input valid. The LOS timer is settable using the CONFIGURE menu of the crossing controller, or using the DT utility. The range is 0 to 20 seconds (default = 0 second), and each enabled input will have an LOS timer in the CONFIGURE menu. In general, wrap inputs should have a minimum of 5 seconds of LOS time programmed.

#### **NOTE**

**NOTE**

Refer to Section 5, paragraph 5.2.1.3, *Using the CONFIGURE Menu*, for configuring Loss-Of-Shunt timer.

### 3.2.5 2TRKDSTK MCF

#### 3.2.5.1 2TRKDSTK MCF Description

The 2TRKDSTK MCF was designed for Double Track with Directional Stick Logic for each track. This MCF utilizes inputs 1-6 for inputting up to 2 tracks for directional stick logic (2 approaches and an island per track). This MCF contains 2 separate Vital Stick Cancellation Timers, one for each track. However, both timers are set to the same value. It also provides a programmable Loss-Of-Shunt (LOS) timer for each input. In addition, the 2GC output can be programmed for Normal operation, Inverted output for exit gate operation, Simultaneous Pre-emption and Advance Pre-emption where the 2GC output drives a traffic pre-empt relay, or Beacon, where 2GC controls an active beacon on a highway-railroad advance warning sign. Input #7 is a configurable input that can be used for crossing activation, traffic pre-emption relay health check, or for test switch. Refer to paragraph 3.3 for using 2GC Output / Input #7 (2GC/I7).

#### 3.2.5.2 2TRKDSTK MCF Operation

The crossing activates when any of the XR inputs deenergizes (figure 3-5).

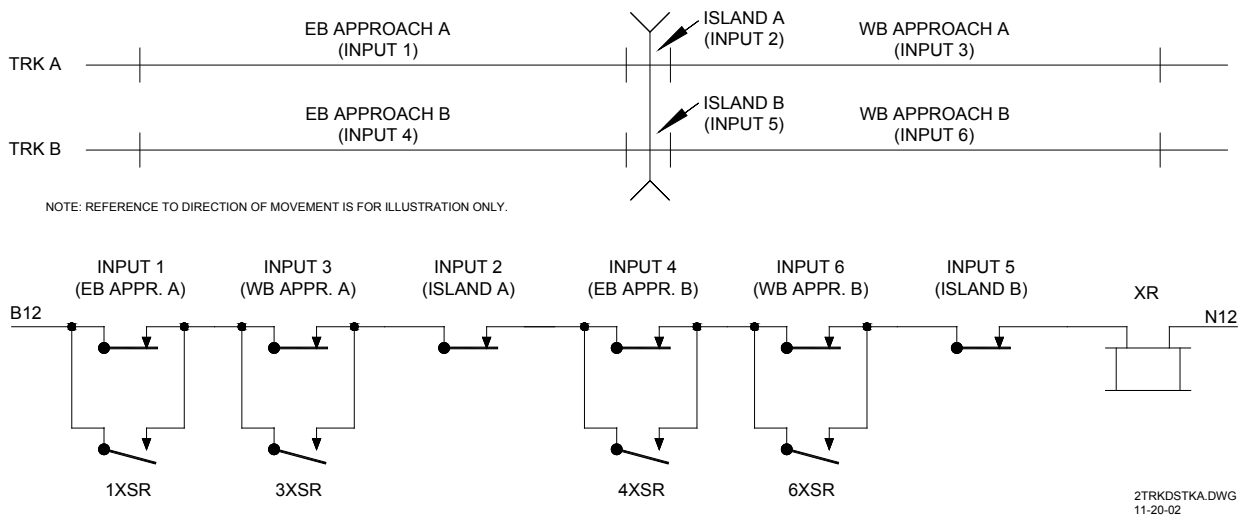

**Figure 3-5. Typical XR Inputs for 2TRKDSTK MCF**

A typical example for Track A is illustrated in figure 3-6.

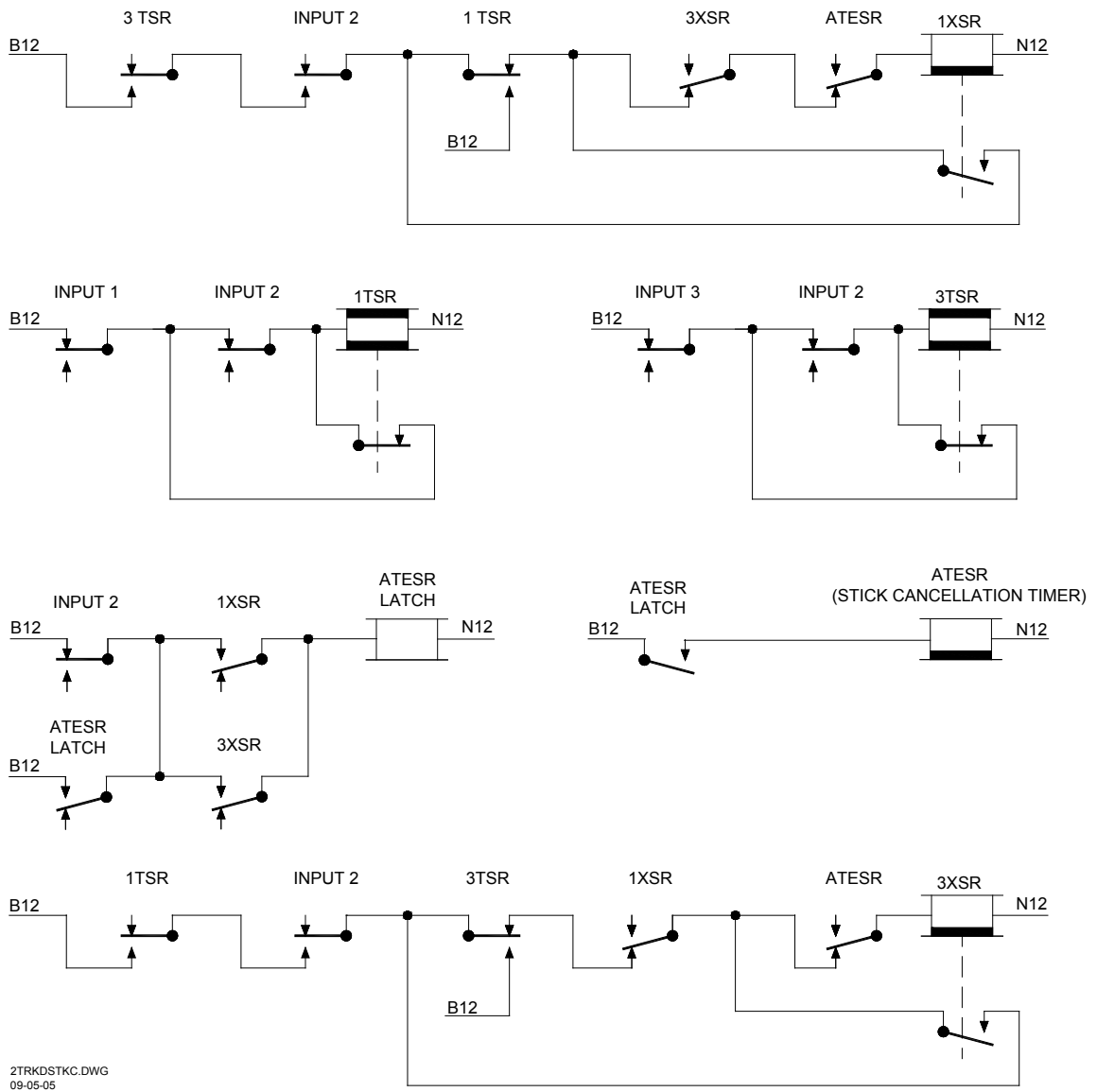

**Figure 3-6. Typical Example for 2TRKDSTK MCF  
(Track A Shown)**

### 3.2.5.3 2TRKDSTK MCF Physical Inputs

The inputs available on the 2TRKDSTK MCF configuration are listed in table 3-6.

**Table 3-6. 2TRKDSTK MCF Inputs**

Input #	Input Function	Optional LOS <sup>[1]</sup>	Notes
1	Track A approach	Yes	
2	Track A Island	Yes	
3	Track A approach	Yes	
4	Track B approach	Yes	Disable in Program menu if not used
5	Track B Island	Yes	
6	Track B approach	Yes	
7	Configurable <sup>[2]</sup>	Yes	
8	GP – (Gate Position) <sup>[3]</sup>	No	Required if gates are used. If no gates are used, disable in Program menu.

[1] LOS = Loss-Of-Shunt timer.

[2] Input 7 is a configurable input (with LOS timer) except when in pre-empt mode. Refer to section 3.2....

[3] Input 8 is intended to be used as the Gate Position (GP) input. Gate wiring should be such that Input #8 is active when all the gates are in the “up” position. When any gate is not detected as “up”, this input becomes deenergized which causes the lamps to flash. If the crossing does not use gates, the GP input must be disabled by setting “Gates Used” to “NO” in the Program menu.

Inputs for a 2TRKDSTK MCF may be from any discrete track circuit, or combination of track circuits, representing each approach circuit and island circuit, such as audio track circuits, DC or AC track circuits, or Style C track circuits. The corresponding input LED flashes when the directional stick is ‘picked’ to bypass that input.

#### **NOTE**

#### **NOTE**

While a flashing input LED indicates that the directional stick is “picked” bypassing that input, it does not indicate that the input is deenergized. When the input LED is flashing and the entering approach and island input LEDs are lit, the directional stick is “stuck” indicating the input is de-energized.

### 3.2.5.4 Stick Cancellation Timer

Referring to figure 3-6, a typical stick cancellation timer is shown for Track A as ATESR . The ATESR begins to run time when the island circuit energizes as the train departs the crossing. Therefore, the stick cancellation time is not affected by train length. The ATESR Latch prevents an intermittent island circuit from resetting the Stick Cancellation Timer. The stick cancellation time is selected in the PROGRAM menu (Program Release Stick Timer).

### 3.2.5.5 Optional Loss-Of-Shunt Timer

The 2TRKDSTK MCF configuration file is equipped with an optional Loss-Of-Shunt timer for all six configured XR inputs and Input #7 (configurable). The Loss-Of-Shunt time is the delay from the time the input energizes to when the logic considers the input valid. The LOS timer is settable using the CONFIGURE menu of the crossing controller, or using the DT utility. The range is 0 to 20 seconds (default = 0 second), and each enabled input will have an LOS timer in the CONFIGURE menu. If no LOS time is required, set the LOS time to zero (0).

#### NOTE

#### NOTE

Refer to Section 5, paragraph 5.2.1.3 *Using the CONFIGURE Menu*, for configuring LOS timer.

### 3.2.5.6 Test Switch Mode

The 2TRKDSTK MCF configuration file is equipped with an optional Test Switch Mode for Input #7 (configurable). In the test switch mode, Input #7 can be programmed to “Activate” the crossing devices, or activate the devices and release the directional sticks (ACT STK REL). Refer to paragraph 3.3 for using additional 2GC Output / Input #7 (2GC/17) features.

#### WARNING

#### WARNING

WHEN IN THE ‘ACTIVATE AND STICK RELEASE’ MODE, THE TEST SWITCH INPUT MUST BE DEENERGIZED FOR AT LEAST TWO (2) SECONDS IN ORDER TO RELEASE THE DIRECTIONAL STICK.

#### WARNING

#### WARNING

IF SIMULTANEOUS OR ADVANCE PREEMPT IS PROGRAMMED, THE TEST SWITCH MODE DOES NOT DEENERGIZE THE PREEMPT RELAY DRIVE WHEN ACTIVATING THE WARNING DEVICES. CARE SHOULD BE TAKEN WHEN USING THE TEST SWITCH TO AVOID GATES STRIKING VEHICLES STOPPED AT THE CROSSING.

#### NOTE

#### NOTE

The test switch will deenergize the preempt relay when used to release a “stuck” directional stick because the receding approach track circuit is deenergized.

### 3.2.6 SUPISL MCF

#### 3.2.6.1 SUPISL MCF Description

The SUPISL MCF was designed for Double Track with Supplemental Island inputs for each track. This MCF utilizes inputs 1-6 for inputting up to 2 tracks with motion or prediction equipment along with their island circuits for crossing controls and also provides a supplemental island input for each track. The supplemental island logic requires that both the island and supplemental island be energized for the island circuit logic to recover. It also provides a programmable Loss-Of-Shunt (LOS) timer for each supplemental island input. In addition, the 2GC output can be programmed for Normal operation, Inverted output for exit gate operation, or Simultaneous Pre-emption and Advance Pre-emption where the 2GC output drives a traffic pre-empt relay, or Beacon, where 2GC controls an active beacon on a highway-railroad advance warning sign. Input #7 is a configurable input that can be used for crossing activation, or for traffic pre-emption relay health check. Refer to paragraph 3.3 for using 2GC Output / Input #7 (2GC/I7).

#### 3.2.6.2 SUPISL MCF Operation

The SUPISL MCF is illustrated in figure 3-7.

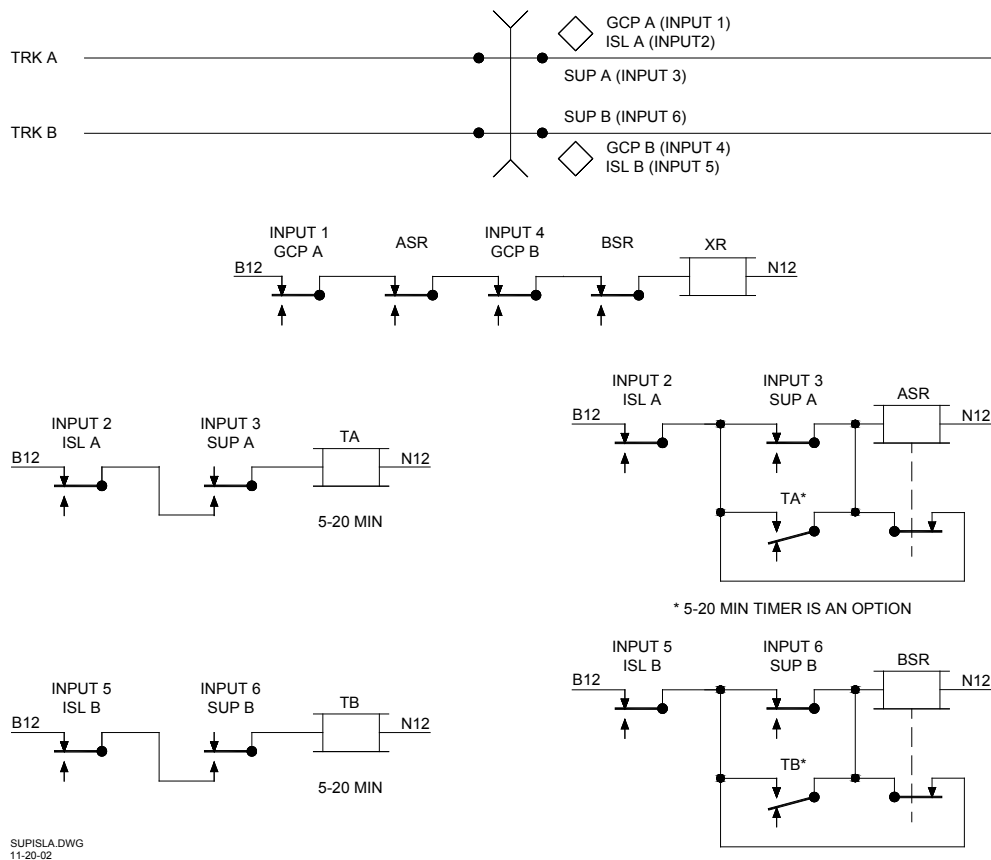

Figure 3-7. Typical XR Inputs for SUPISL MCF



### 3.2.6.3 SUPISL MCF Physical Inputs

The inputs available on the SUPISL MCF are listed in table 3-7.

**Table 3-7. SUPISL MCF Inputs**

Input #	Input Function	Optional LOS <sup>[1]</sup>	Notes
1	Track A GCP	No	
2	Track A Island	No	
3	Track A Supplemental Island <sup>[2]</sup>	Yes	
4	Track B GCP	No	Disable in Program menu if not used
5	Track B Island	No	
6	Track B Supplemental Island <sup>[2]</sup>	Yes	
7	Configurable <sup>[3]</sup>	Yes	
8	GP – (Gate Position) <sup>[4]</sup>	No	Required if gates are used. If no gates are used, disable in Program menu.

[1] LOS = Loss-Of-Shunt timer.

[2] The Supplemental Island time is selected in the PROGRAM menu.

[3] Input 7 is a configurable input (with LOS timer) except when in pre-empt mode. Refer to section 3.2.

[4] Input 8 is intended to be used as the Gate Position (GP) input. Gate wiring should be such that Input #8 is active when all the gates are in the “up” position. When any gate is not detected as “up”, this input becomes deenergized which causes the lamps to flash. If the crossing does not use gates, the GP input must be disabled by setting “Gates Used” to “NO” in the Program menu.

### 3.2.6.4 Optional Loss-Of-Shunt Timer

The SUPISL MCF file is equipped with optional Loss-Of-Shunt timer for only the supplemental Island inputs and input #7 (configurable). The Loss-Of-Shunt time is the delay from the time the input energizes to when the logic considers the input valid. The LOS timer is settable using the CONFIGURE menu of the crossing controller, or using the DT utility. The range is 0 to 20 seconds (default = 0 second), and each enabled input will have an LOS timer in the CONFIGURE menu. If no LOS time is required, set the LOS time to zero (0). The island does not recover until both the regular island and the supplemental island energize.

#### **NOTE**

**NOTE**

Refer to Section 5, paragraph 5.2.1.3, *Using the CONFIGURE Menu*, for configuring Loss-Of-Shunt timer.

### 3.2.6.5 Supplemental Island Timer

The supplemental island timer allows the warning devices to turn off if the island energizes and the supplemental island fails to energize after a predetermined period of time. Refer to the relay equivalent diagram in figure 3-7 for the equivalent circuit. Refer to Section 4, figure 4-21 for the SUPISL.MCF program menu flow diagram.

### 3.2.7 3TRK2TRN MCF

#### 3.2.7.1 3TRK2TRN MCF Description

The 3TRK2TRN MCF was designed for Triple Track, Second Train Coming Logic. This MCF utilizes inputs 1-6 for inputting up to 3 predictors and 3 pre-emption DAXs for improved operation on multiple track crossings. When a train is just leaving an island circuit, the DAX inputs on the other tracks are checked to verify that no other train is within the DAX warning time. If a second train is present, the crossing gates and flashers do not recover as the train leaves the island but remain activated for the second train. No Loss-Of-Shunt (LOS) timers are allowed on the inputs. In addition, the 2GC output can be programmed for Normal operation, Inverted output for exit gate operation, Simultaneous Pre-emption and Advance Pre-emption where the 2GC output drives a traffic pre-empt relay, or Beacon, where 2GC controls an active beacon on a highway-railroad advance warning sign. Input #7 is a configurable input that can be used for crossing activation, or for traffic pre-emption relay health check. Refer to paragraph 3.3 for using 2GC Output / Input #7 (2GC/17).

#### 3.2.7.2 3TRK2TRN MCF Operation

Typical 3TRK2TRN MCF operation is illustrated in figure 3-8).

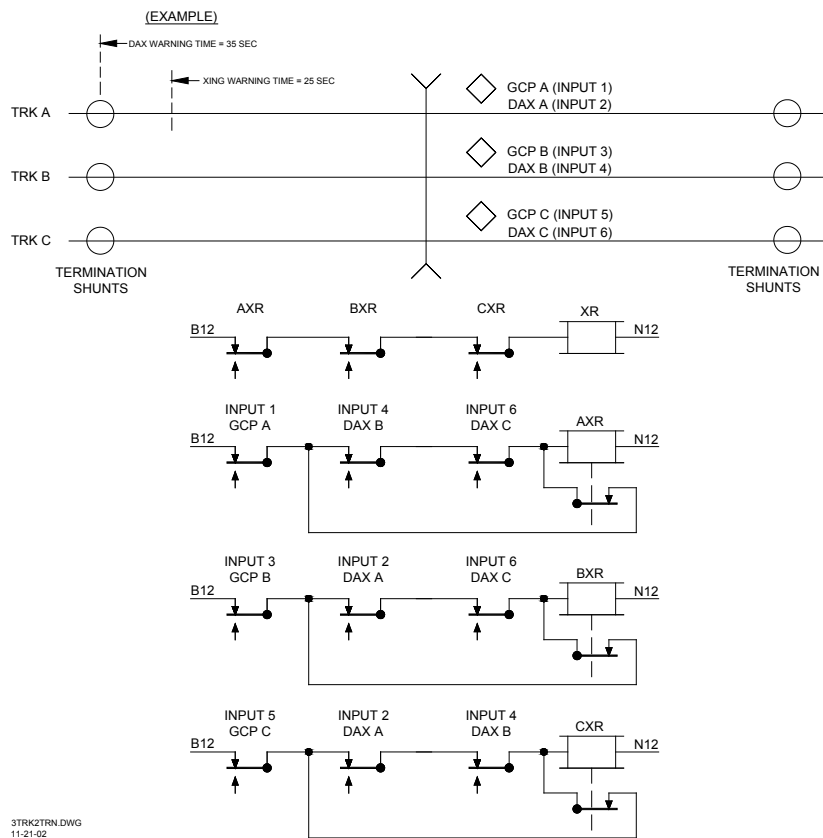

Figure 3-8. Typical XR Inputs for 3TRK2TRN MCF

### 3.2.7.3 3TRK2TRN MCF Physical Inputs

The inputs available on the 3TRK2TRN MCF are listed in table 3-8.

**Table 3-8. 3TRK2TRN MCF Inputs**

Input #	Input Function	Optional LOS <sup>[1]</sup>	Notes
1	GCP A	No	
2	DAX A	No	
3	GCP B	No	Disable in Program menu if not used
4	DAX B	No	
5	GCP C	No	Disable in Program menu if not used
6	DAX C	No	
7	Configurable <sup>[2]</sup>	Yes	
8	GP – (Gate Position) <sup>[3]</sup>	No	Required if gates are used. If no gates are used, disable in Program menu.

[1] LOS = Loss-Of-Shunt timer.

[2] Input 7 is a configurable input (with LOS timer) except when in pre-empt mode. Refer to section 3.2.

[3] Input 8 is intended to be used as the Gate Position (GP) input. Gate wiring should be such that Input #8 is active when all the gates are in the “up” position. When any gate is not detected as “up”, this input becomes deenergized which causes the lamps to flash. If the crossing does not use gates, the GP input must be disabled by setting “Gates Used” to “NO” in the Program menu.

### 3.2.7.4 Optional Loss-Of-Shunt Timer

The 3TRK2TRN.MCF configuration file is equipped with optional Loss-Of-Shunt timer only for input #7 (configurable input). The Loss-Of-Shunt time is the delay from the time the input energizes to when the logic considers the input valid. The LOS timer is settable using the CONFIGURE menu of the crossing controller, or using the DT utility. The range is 0 to 20 seconds (default = 0 second), and each enabled input will have an LOS timer in the CONFIGURE menu. If no LOS time is required, set the LOS time to zero (0).

#### **NOTE**

#### **NOTE**

Refer to Section 5, paragraph 5.2.1.3, *Using the CONFIGURE Menu*, for configuring Loss-Of-Shunt timer.

### 3.2.8 2TRK2TRN MCF

#### 3.2.8.1 2TRK2TRN MCF Description

The 2TRK2TRN MCF was designed for Double Track, Second Train Coming Logic. This MCF utilizes inputs 1-6 for inputting up to 2 predictors and 2 pre-emption DAXs for improved operation of multiple track crossings. It also provides 2 wrap inputs. When a train is just leaving an island circuit, the DAX input on the other track is checked to verify that no other train is within the DAX warning time. If a second train is present, the crossing gates and flashers do not recover as the train leaves the island but remain activated for the second train. Loss-Of-Shunt (LOS) timers are allowed only on the wrap inputs and Input #7 (configurable). In addition, the 2GC output can be programmed for Normal operation, Inverted output for exit gate operation, Simultaneous Pre-emption and Advance Pre-emption where the 2GC output drives a traffic pre-empt relay, or Beacon, where 2GC controls an active beacon on a highway-railroad advance warning sign. Input #7 is a configurable input that can be used for crossing activation, or for traffic pre-emption relay health check. Refer to paragraph 3.3 for using 2GC Output / Input #7 (2GC/I7).

#### 3.2.8.2 2TRK2TRN MCF Operation

Typical 2TRK2TRN MCF operation is illustrated in figure 3-9.

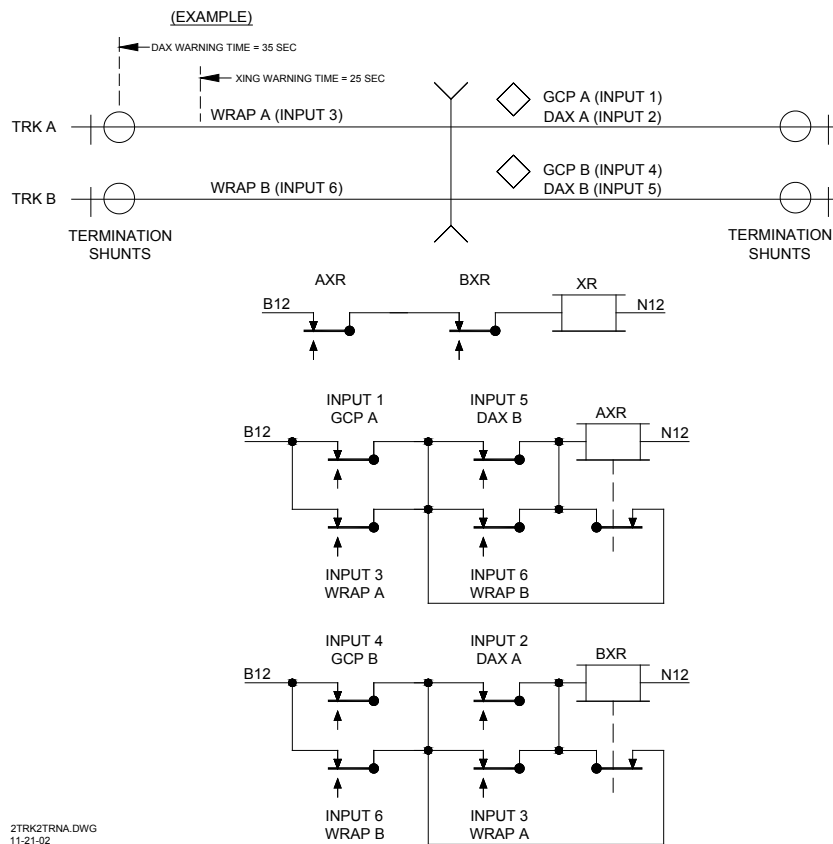

Figure 3-9. Typical XR Inputs for 2TRK2TRN MCF

### 3.2.8.3 2TRK2TRN MCF Physical Inputs

The inputs available on the 2TRK2TRN MCF are listed in table 3-9.

**Table 3-9. 2TRK2TRN MCF Inputs**

Input #	Input Function	Optional LOS <sup>[1]</sup>	Notes
1	GCP A	No	
2	DAX A	No	
3	WRAP A	Yes	
4	GCP B	No	Disable in Program menu if not used
5	DAX B	No	
6	WRAP B	Yes	
7	Configurable <sup>[2]</sup>	Yes	
8	GP – (Gate Position) <sup>[3]</sup>	No	Required if gates are used. If no gates are used, disable in Program menu.

[1] LOS = Loss-Of-Shunt timer.

[2] Input 7 is a configurable input (with LOS timer) except when in pre-empt mode. Refer to section 3.2.

[3] Input 8 is intended to be used as the Gate Position (GP) input. Gate wiring should be such that Input #8 is active when all the gates are in the “up” position. When any gate is not detected as “up”, this input becomes deenergized which causes the lamps to flash. If the crossing does not use gates, the GP input must be disabled by setting “Gates Used” to “NO” in the Program menu.

### 3.2.8.4 Optional Loss-Of-Shunt Timer

The 2TRK2TRN MCF configuration file is equipped with optional Loss-Of-Shunt timers for all configured Wrap inputs and Input #7 (configurable). The Loss-Of-Shunt time is the delay from the time the input energizes to when the logic considers the input valid. The LOS timer is settable using the CONFIGURE menu of the crossing controller, or using the DT utility. The range is 0 to 20 seconds (default = 0 second), and each enabled input will have an LOS timer in the CONFIGURE menu. If no LOS time is required, set the LOS time to zero (0).

#### **NOTE**

#### **NOTE**

Refer to Section 5, paragraph 5.2.1.3, *Using the CONFIGURE Menu*, for configuring Loss-Of-Shunt timer.

### 3.2.9 DAXPRMT MCF

#### 3.2.9.1 DAXPRMT MCF Description

The DAXPRMT MCF was designed for DAX-based Advance Pre-emption of Traffic Signals on 3 track circuits. This MCF utilizes inputs 1-6 for inputting up to 3 predictors and up to 3 Advance Pre-emption DAXs. When the 2GC output of a 40-Amp unit (20-Amp units do not have the capability to execute DAXPRMPT MCF) is programmed for Advance Pre-emption, an Advance Pre-empt Timer is then available in the PROGRAM menu for setting the interval time between the traffic pre-emption warning time and the crossing warning time. No Loss-Of-Shunt timers are allowed on the inputs. The 2GC output is programmed for Advance Pre-emption where the 2GC output drives the traffic pre-empt relay.

**NOTE****NOTE**

If LOS timer functionality is required, it should be a function of the train detection equipment providing input to the crossing controller.

#### 3.2.9.2 DAXPRMT MCF Operation

When the DAX input from the GCP to the SSCC III PLUS detects a train, the controller 2GC output deenergizes the Traffic Signal Pre-empt relay. The crossing activates when a programmed Advance Pre-empt timer runs out or the input from the GCP deenergizes (figure 3-10).

**NOTE****NOTE**

Effective with version 'F' of this MCF, the Advance Pre-empt Timer must complete before the Minimum Activation Timer begins. This results in the forcing the complete cycling of Advance Pre-empt and Minimum Activation times, even in the event of a false train detection.

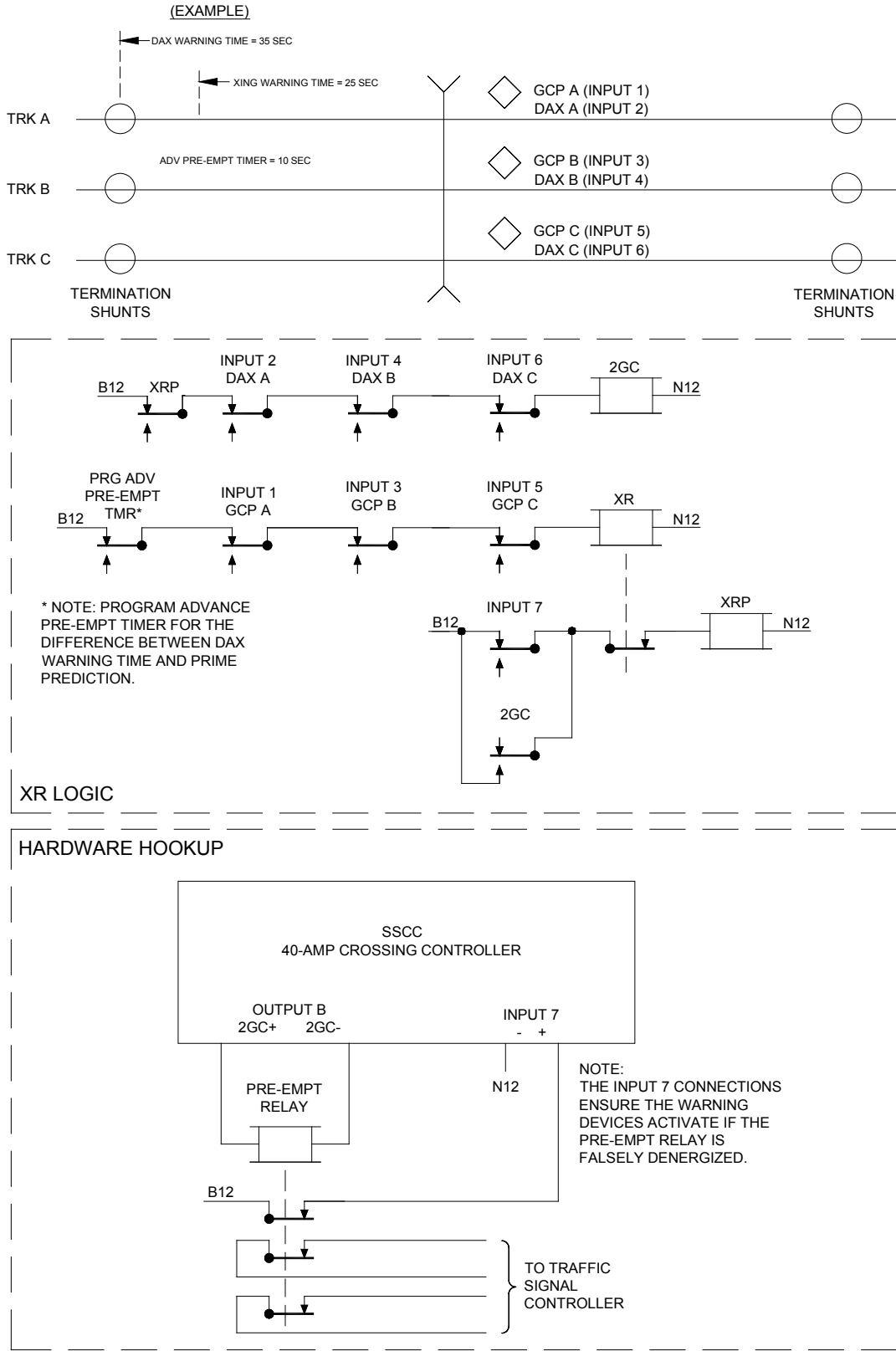

**Figure 3-10. Typical XR Inputs for DAXPRMT MCF**

### 3.2.9.3 DAXPRMT MCF Physical Inputs

The inputs available on the DAXPRMT MCF are listed in table 3-10.

**Table 3-10. DAXPRMT MCF Inputs**

Input #	Input Function	Optional LOS <sup>[1]</sup>	Notes
1	GCP A	No	Always enabled (Track A)
2	DAX A	No	Always enabled (Track A)
3	GCP B	No	Disable in Program menu if not used
4	DAX B	No	
5	GCP C	No	Disable in Program menu if not used
6	DAX C	No	
7	ADV PRE-EMPT	No	Wiring to Pre-empt relay required
8	GP – (Gate Position) <sup>[2]</sup>	No	Required if gates are used. If no gates are used, disable in Program menu.

[1] LOS = Loss-Of-Shunt timer.

[2] Input 8 is intended to be used as the Gate Position (GP) input. Gate wiring should be such that Input #8 is active when all the gates are in the “up” position. When any gate is not detected as “up”, this input becomes deenergized which causes the lamps to flash. If the crossing does not use gates, the GP input must be disabled by setting “Gates Used” to “NO” in the Program menu.

### 3.2.9.4 Optional Loss-Of-Shunt Timer

The DAXPRMT MCF file does not provide Loss-Of-Shunt timers for any inputs.

## 3.3 USING 2GC OUTPUT/INPUT #7 MODE (2GC/I7)

For some MCFs, Input #7 and/or the 2GC output (40-Amp SSCC III PLUS unit only) may be used in specific modes. Refer to Section IV, table 4-1 for programming 2GC/I7.

### NOTE

### NOTE

All MCFs except BASIC and DAXPRMT provide the same programming step (2GC/I7) where the 2GC output of a 40-Amp SSCC PLUS unit can be programmed for several options (DAXPRMT is always set to Advance Pre-emption). These options are: Normal operation, Inverted Output for exit gate operation, Simultaneous or Advance Pre-emption where the 2GC output drives a traffic pre-empt relay, or Beacon, where 2GC controls an active beacon on a highway-railroad advance warning sign. Input 7 is generally used in pre-emption applications, but can be used for a test switch or an additional island circuit. An Advance Pre-emption application using prediction equipment is described in paragraph 3.2.9, *DAXPRMT MCF*.



### 3.3.1 2GC Normal Operation (Both 20 Amp and 40 Amp Models)

In the Normal mode, the 2GC output is used to control an entrance gate. The gate delay time range is 3 to 20 seconds. The 2GC output is normally energized. When a train is detected and the internal XR deenergizes based on the MCF logic, the gate delay timer operates. Upon completion of the gate delay time, the 2GC output deenergizes.

### 3.3.2 2GC Inverted Operation (40 Amp Models Only)

In the Inverted mode, the 2GC output is used to control exit gate mechanisms that are designed for Four Quadrant Gate applications. The exit gates are designed to release and raise from the horizontal position to a vertical position sufficient to allow vehicle clearing of the crossing under a loss of power condition or when GC is removed. In the Inverted mode, the 2GC output is normally deenergized. When a train is detected and the internal XR deenergizes based on the MCF logic, the gate delay timer operates. Upon completion of the gate delay time, the 2GC output energizes applying voltage to the down control in the exit gate mechanism.

### 3.3.3 2GC Traffic Signal Simultaneous Preemption Relay Drive (40 Amp Models Only)

The 2GC output may be programmed as a vital relay drive for simultaneous preemption of traffic signals. In the simultaneous mode, the 2GC gate delay timer is set to 0 seconds and the 2GC output deenergizes when a train is detected and the internal XR deenergizes based on the MCF logic.

When the train leaves the island circuit and the internal XR energizes, the 2GC preemption relay drive is energized at the same time the 1GC energizes. This terminates the preempt call as the gates begin to rise and allows the traffic signal controller to reset. It also allows the controller to perform a second preemption clearout if a second train arrives.

### 3.3.4 2GC Traffic Signal Advance Preemption Relay Drive (40 Amp Models Only)



#### WARNING

**WHEN “PRE-EMPT ADV” IS SELECTED, THE ACTIVATION OF THE WARNING DEVICES IS DELAYED BY THE ADVANCE PREEMPTION TIMER. THEREFORE, APPROACH DISTANCES MUST BE INCREASED TO ALLOW FOR THE PROPER TOTAL WARNING TIME AFTER THE DELAY.**

The 2GC output may be programmed as a vital relay drive for advance preemption of traffic signals. In the advance mode, the 2GC gate delay timer is set to 0 seconds and the 2GC output deenergizes when a train is detected and the internal XR deenergizes based on the MCF logic. However, the warning devices do not operate until the completion of the advance preempt timer operation (1 to 99 seconds). In other words, the traffic signal is preempted in advance of the warning devices operating.

The warning devices are also activated at the completion of the advance preempt timer operation in the DAXPRMT MCF even if the DAX input remains energized. This minimizes the possibility of a decelerating train allowing the traffic signal clearance interval to complete prior to the warning devices activating.

When the train leaves the island circuit and the internal XR energizes, the 2GC preemption relay drive is energized at the same time the 1GC energizes. This terminates the preempt call as the gates begin to rise and allows the traffic signal controller to reset. It also allows the controller to perform a second preemption clearout if a second train arrives.

### 3.3.5 2GC Active Beacon Relay Drive for Advance Warning Signs (40 Amp Models Only)



#### WARNING

**WHEN “BEACON” IS SELECTED, THE ACTIVATION OF THE WARNING DEVICES IS DELAYED BY THE ADVANCE PREEMPTION TIMER. THEREFORE, APPROACH DISTANCES MUST BE INCREASED TO ALLOW FOR THE PROPER TOTAL WARNING TIME AFTER THE DELAY.**

#### NOTE

#### NOTE

Active Beacons are one or more flashing yellow signal heads on Highway-Railroad Advance Warning Sign masts that are used provide supplemental emphasis to the advance warning sign while the highway-railroad grade crossing warning devices are activated. Active beacons may be installed by the highway agency when curves or hills restrict preview of a highway-railroad grade warning system.

The 2GC output may be programmed as a vital relay drive for Beacon control. In the BEACON mode, the gate delay timer is set to 0 seconds and the 2GC deenergizes when a train is detected and the internal XR deenergizes based on the MCF logic. However, the warning devices do not operate until the completion of the advance preempt timer operation (1 to 99 seconds). In other words, the traffic signal is preempted in advance of the warning devices operating.

In the simultaneous mode, the gate delay timer is set to 0 seconds and the 2GC deenergizes when a train is detected and the internal XR deenergizes based on the MCF logic

**NOTE****NOTE**

The main difference between beacon control and preempt control is a BEACON DELAY TIMER may be used to keep the beacon activated a period of time after the warning devices deactivate. The purpose of the delay time is to provide time for traffic stopped at the crossing to resume speed before the active beacon is turned off. The delay time is determined by engineering study.

**WARNING****WARNING**

**DO NOT USE THE BEACON MODE TO PREEMPT TRAFFIC SIGNALS. THE BEACON DELAY TIMER DELAYS THE RESETTING OF THE TRAFFIC SIGNAL CONTROLLER WHICH MAY PREVENT A CLEAR-OUT INTERVAL FOR A SECOND TRAIN.**

**3.3.6 Input 7 in the Preemption Modes**

In both the simultaneous preemption mode and the advance preemption mode, Input 7 should be used in the preempt health check mode, (PRMT HEALTH). Refer to figure 3-10, *Typical XR inputs for DAXPRMT MCF*, for wiring of preemption health check.

The purpose of the preemption health check is to activate the highway-railroad grade crossing warning devices in the event of a malfunction of the preemption relay circuit. Without the preemption health check, a defective preemption relay or an open wire in the preemption relay circuit would result in the preemption relay being falsely deenergized, thereby falsely preempting the traffic signals. If this occurred, the traffic signals would remain at STOP after the initial clear-out cycle without the warning devices warning traffic to remain off the tracks. The vehicular traffic stopped at the signal would not receive a clear-out green traffic signal, which would allow them to proceed off the tracks.

**WARNING****WARNING**

**THE PREEMPTION RELAY HEALTH CHECK SHOULD BE USED TO INSURE THAT THE WARNING DEVICES ARE ACTIVATED IF THE TRAFFIC SIGNALS ARE FALSELY PREEMPTED.**

**NOTE****NOTE**

The BEACON mode does not require a health check because falsely activating the beacon causes a more restrictive failure in advance of the crossing.

This page intentionally left blank

## SECTION 4 DISPLAYS & MENU DESCRIPTIONS

### 4.1 GENERAL

This section defines the function of each menu display. The menu descriptions in this section are provided for general information only. The procedures for using the Program, Configure and Test Configure menus are provided in Section 5, the procedures for using the Setup Lamp Voltages and Test menus are provided in Section 6, and the procedure for using the Query menu is provided in Section 9.

### 4.2 MAIN MENU

The main menu is the top level of the menu system. The default position in the main menu is the Idle Screen (see figure 4-1), which is automatically accessed shortly after bootup.

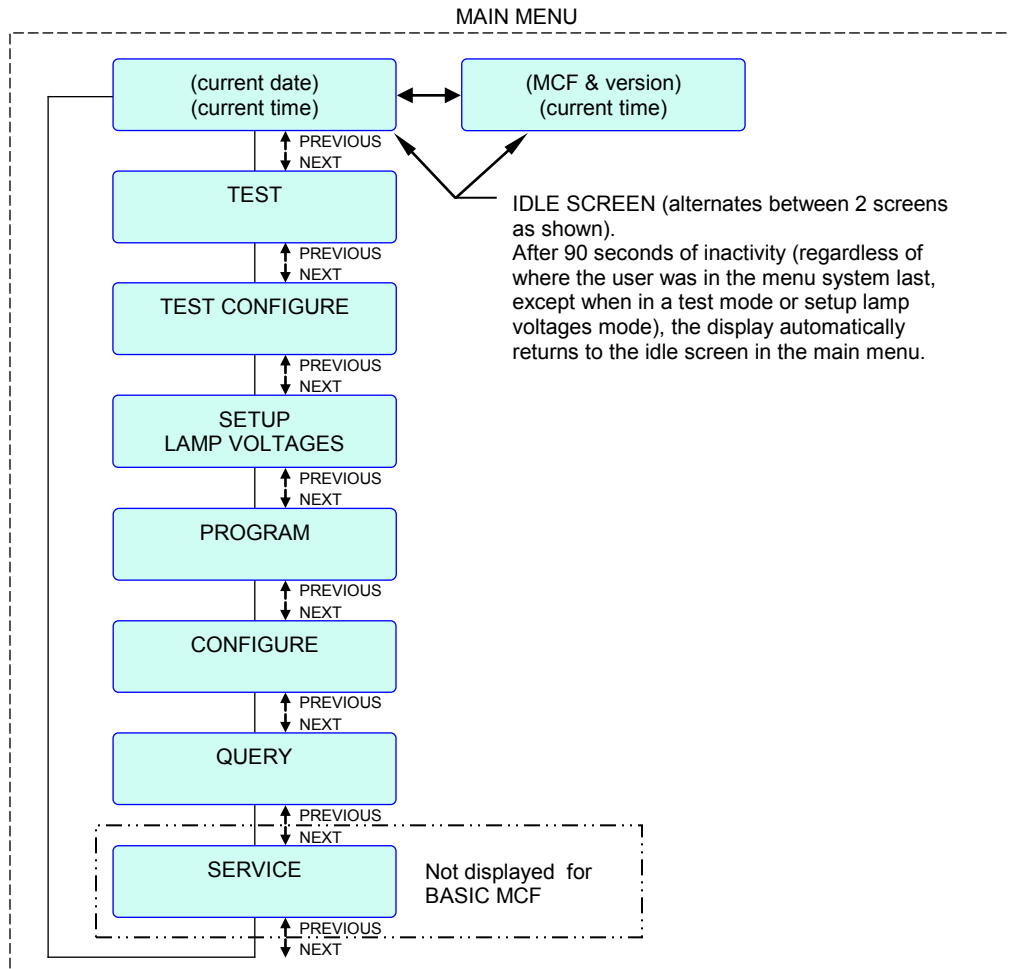

**Figure 4-1. SSCC III PLUS Main Menu**

Each submenu of the main menu has an EXIT function to return to the main menu, or after 90 seconds of inactivity the display automatically returns to the idle screen in the main menu.

**NOTE**

**NOTE**

If the 90 second inactivity timeout is allowed to occur while in an edit mode, the system reverts to the idle screen and any changes that were made without saving will be lost.

**NOTE**

**NOTE**

When in edit mode of any of the menus, the values or options in the edit field wrap around at the value or option limits.

**4.2.1 PROGRAM Menu**

The PROGRAM menu is the primary programming tool for system applications. See figures 4-11 through 4-28 for Configure and Program menus at the end of this section.

**WARNING**

**WARNING**

**IT IS NECESSARY TO SELECT THE PROPER MCF FILE PRIOR TO PROGRAMMING ANY STEPS IN THE PROGRAM MENU AND THE MCF MUST CORRESPOND WITH THE CROSSING WIRING. FAILURE TO DO SO MAY CAUSE THE CROSSING NOT TO ACTIVATE.**

**IF A DIFFERENT MCF IS SELECTED, ALL PARAMETERS NEED TO BE RE-ENTERED/ RECHECKED.**

**WARNING**

**WARNING**

**ALL PROGRAM AND CONFIGURE PARAMETERS MUST BE SET TO APPROVED RAILROAD DESIGN AND APPLICABLE GOVERNMENT REGULATIONS.**

**NOTE**

**NOTE**

Program menu displays differ, depending on the application software (MCF) selected in the crossing controller. Refer to figures 4-11 through 4-28 at the end of this section for Configure and Program menus for the different MCFs.

When any changes are made (in Program edit mode), changes are saved when the user presses <Enter>, and a “saving changes” message is displayed.

SAVING  
CHANGES...

**NOTE**

**NOTE**  
Whenever the password function is enabled and there is no rocker switch activity for 90 seconds, the user will be prompted to enter the correct password before Program parameters can be changed.

**NOTE**

**NOTE**  
Several menu items are not visible if the unit is in “Out of Service” mode.

#### 4.2.1.1 Program Lamp Flash Rate

The rate at which the crossing lamps flash can be set by using the **PRG FLASH RATE** menu. The range is 30 flashes per minute to 70 flashes per minute (default = 50 flashes per minute).

PRG FLASH  
RATE: 50 PER MIN

#### 4.2.1.2 Program Gates Used (not available for BASIC MCF)

When gates are used at a crossing, select **YES** for PRG GATES USED. When flashers only are used, select **NO**.

PRG GATES USED  
YES

When **NO** is selected for Program Gates Used, internal logic locks out the GP input, therefore no jumper is required from the Battery to the GP input to prevent continuous flasher operation. In addition, when **NO** is selected, the 1GC, 2GC Gate Delay Timer, and Gate Rising Bell programming steps are hidden from view in the menu system.

#### 4.2.1.3 Program Gate Delay Timers

Normally, when a crossing controller is activated, the lights begin to flash before the gates begin to descend. Gate delay 1 timer is a function in both the 20-Amp and 40-Amp units to provide this gate delay for the “A” output. This timer is settable by using the **PRG 1GC DELAY TMR** menu. The range is 3 seconds through 20 seconds (default = 4 seconds).

PRG 1GC DELAY  
TMR: 4 sec

Gate delay 2 timer is a function only in the 40-Amp unit to provide this gate delay for the “B” output. This timer is settable by using the **PRG 2GC DELAY TMR** menu. The range is 3 seconds through 20 seconds (default = 4 seconds).

PRG 2GC DELAY  
TMR: 4 sec

**NOTE**

**NOTE**

The PRG 2GC DELAY menu is only applicable for the 40-Amp crossing controller unit. This menu appears when PRG GATES USED is set to “YES” and when the PRG 2GC/I7 MODE is set to “Normal” or “Inverted”.

**NOTE**

**NOTE**

If a gate control is not used, its corresponding gate delay time must be set to a value that is equal to or less than the used gate delay time. For example, if GC2 is not used, then it must be set to a value equal to or less than GC1.

**4.2.1.4 Program Gate Rising Bell Off**

The bell(s) at a crossing can be configured to ring (set to ON) as the gates are rising, or not ring (set to OFF), by using the **PRG GATE RISING BEL** menu. The default setting is ON.

PRG GATE RISING  
BEL: ON

**NOTE**

**NOTE**

The “Program Gate Rising Bell” menu is only displayed when PRG GATES USED is not “NO”.

**4.2.1.5 Program Enabled Inputs**

**WARNING**

**WARNING**

**AN INPUT CANNOT BE USED TO ACTIVATE A CROSSING IF IT IS NOT ENABLED.**

The SSCC III PLUS has a total of 8 vital inputs: seven activation inputs (#1 through #7) and a Gate Position (GP) input (#8). The activation inputs are enabled or disabled for the SSCC III PLUS by using a menu specific to the loaded MCF.

Each MCF has a different use of the inputs, therefore the programming for each MCF depends on which MCF is selected. Refer to Section 3 for detailed application information on inputs. Examples of the different MCF menu displays for enabling inputs for SSCC III PLUS are shown in table 4-1.



**Table 4-1. SSCC III PLUS Displays for Enabling Inputs (by MCF)**

BASIC	BASICPLS	3TRK1WRP 3TRK2TRN	2TRK2WRP 2TRKDSTK 2TRK2TRN, SUPISL	DAXPRMT
PRG ENBLD INPUTS 1 THRU 1	PRG INPUT 2 ENABLED	PRG INPUT 3,4 ENABLED	PRG INPUT 4, 5, 6 ENABLED	PRG INPUT 3,4, ENABLED
PRG ENBLD INPUTS 1 THRU 2	PRG INPUT 3 ENABLED	PRG INPUT 5,6 ENABLED	PRG INPUT 7 ENABLED	PRG INPUT 5,6 ENABLED
PRG ENBLD INPUTS 1 THRU 3	PRG INPUT 4 ENABLED	PRG INPUT 7 ENABLED		
PRG ENBLD INPUTS 1 THRU 4	PRG INPUT 5 ENABLED			
PRG ENBLD INPUTS 1 THRU 5	PRG INPUT 6 ENABLED			
PRG ENBLD INPUTS 1 THRU 6	PRG INPUT 7 ENABLED			
PRG ENBLD INPUTS 1 THRU 7				

**NOTE**

Inputs (#2 through #7) may be enabled/disabled depending on the MCF and the inputs used. However, only Input #8 (GP) is enabled/disabled through the **PRG GATES USED** menu.

**NOTE**

When 2GC/I7 is set for SIM or ADV preemption, the default setting for Input 7 is Preempt Health in MCFs BASICPLS, 3TRK1WRP, 3TRK2TRN, 2TRK2WRP, 2TRKDSTK, 2TRK2TRN, AND SUPISL.

**NOTE**

At initial cut-over, the crossing will generally be constantly activated until the proper SSCC III PLUS inputs have been enabled and the control to the inputs is high.

**4.2.1.6 Program 2GC/I7 MODE (40-Amp Unit Only) (not available for BASIC or DAXPRMT)**



**WARNING**

**WHEN EXIT GATES ARE USED, SET EXIT GATE DELAY TIMERS IN ACCORDANCE WITH CIRCUIT PLANS. DELAY TIMES ARE DETERMINED BY ENGINEERING STUDY AND ARE GENERALLY LONGER THAN ENTRANCE GATE TIMERS TO PROVIDE VEHICLES TIME TO PASS THE EXIT GATES.**

A typical example of a menu display for PRG 2GC/I7 MODE is shown below:

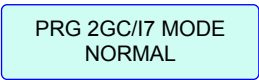

For certain MCFs, Input #7 and/or 2GC output (40-Amp SSCC III PLUS only) may be used for specific applications. To program 2GC/I7, use the **PRG 2GC/I7** menu. The options are NORMAL, INVERTED, PRE-EMPT SIM, PRE-EMPT ADV and BEACON. Table 4-2 indicates those applications.

**Table 4-2. 2GC/I7 Options**

MCF #s	Application	XR Operation	Input #7 Used For:	2GC Used For:
All except DAXPRMT	Normal	Controlled by Inputs 1 - 7	Crossing activation	Gate control
All except BASIC, DAXPRMT	Inverted 2GC	Controlled by Inputs 1 - 7	Crossing activation	Inverted gate control <sup>[1]</sup>
	Pre-empt Simultaneous	Controlled by Inputs 1 - 6	Pre-empt feedback <sup>[2]</sup>	Drive Pre-empt relay
	Beacon	Controlled by Inputs 1 - 6	Crossing activation	Drive Beacon relay
All except BASIC	Pre-empt Advance	Delayed after Inputs 1 - 6	Pre-empt Health <sup>[2]</sup>	Drive Pre-empt relay

[1] Inverted Gate Control is typically used for Exit Gate application.

[2] Pre-empt Health, if low, will activate the crossing without dropping the internal XR. LED #7 on the crossing controller will flash to indicate this condition. Pre-empt Health is used to ensure that a falsely de-energized pre-empt relay (i.e., open coil wire, etc.) does not falsely pre-empt the traffic signals without also activating the warning devices.



**WARNING**

**THE PREEMPTION RELAY HEALTH CHECK SHOULD BE USED TO INSURE THAT THE WARNING DEVICES ARE ACTIVATED IF THE TRAFFIC SIGNALS ARE FALSELY PREEMPTED.**



**NOTE**

DAXPRMT MCF is automatically set for Advance Pre-emption mode. The Normal, Inverted 2GC, Pre-empt Simultaneous, and Beacon modes cannot be selected for 2GC/I7 when DAXPRMT MCF is loaded.

**NOTE****NOTE**

A 20-Amp SSCC IV unit does not have a 2GC output, and therefore cannot execute DAXPRMT MCF. A 40-Amp unit must be used with DAXPRMT MCF.

**4.2.1.7 Program Advance Pre-emption Time (40-Amp unit only) (not available for BASIC)****WARNING****WARNING**

WHEN “ADVANCE PRE-EMPTION TIMER” IS SELECTED, THE ACTIVATION OF THE WARNING DEVICES IS DELAYED. THEREFORE, APPROACH DISTANCES MUST BE INCREASED TO ALLOW FOR THE PROPER TOTAL WARNING TIME AFTER THE DELAY.

**NOTE****NOTE**

When the DAXPRMT MCF is selected, the pre-empt is effective when the DAX input is deenergized. The warning devices activate when the GCP input is deenergized, or when the advance pre-emption timer completes its cycle.

When the 2GC output for an SSCC III PLUS unit (40-Amp unit only) is configured for Advance Pre-emption, the pre-emption time can be set using the ADV PRE-EMPT TIMER menu. The range is 1 to 99 seconds in 1-second increments, and the default is 1 second. A typical example of a menu display for ADV PRE-EMPT TIME is shown below:

```
PRG ADV PRE-EMPT
TMR:           1 sec
```

**NOTE****NOTE**

This timer menu is not displayed unless Advanced Pre-emption or Beacon is selected (PRG 2GC/I7 MODE = PRE-EMPT ADV).

**4.2.1.8 Program Minimum Activation Time**

The “Minimum activation time” function provides an automatic minimum time the flashers and gates will operate once the flashers have been activated. This timer may be used to allow gates to have sufficient time to completely lower, or allow warning devices to activate once advance traffic signal pre-emption completes.

**NOTE**

**NOTE**

Effective with the current MCF releases (see Appendix B), the Advance Pre-empt Timer must complete before the Minimum Activation Timer begins. This results in forcing the complete cycling of Advance Pre-empt and Minimum Activation times, even in the event of a false train detection.

The Minimum activation time can be set using the **PRG MIN ACTIVATE TMR** menu. The range is 0 to 99 seconds in 1-second increments, and the default is 20 seconds for all MCFs except BASIC, which defaults to 0 (zero).

A typical example of a menu display for MIN ACTIVATION TIME is shown below:

PRG MIN ACTIVATE  
TMR: 20 sec

**4.2.1.9 Program Beacon Delay Time (40-Amp unit only)(n/a for BASIC and DAXPRMT MCFs)**

**WARNING**

**WARNING**

**DO NOT USE THE BEACON MODE TO PREEMPT TRAFFIC SIGNALS. THE BEACON DELAY TIMER DELAYS THE RESETTING OF THE TRAFFIC SIGNAL CONTROLLER WHICH MAY PREVENT A CLEAR-OUT INTERVAL FOR A SECOND TRAIN.**

This menu display appears only when the Beacon mode is selected in the PRG 2GC/I7 menu. This timer allows the advance warning highway beacons to continue to warn motorists after the crossing is clear but before stopped traffic is moving again. This timer ranges from 5 to 600 seconds in increments of 5 seconds. The default is 30 seconds.

PRG BEACON DELAY  
TMR: 30 sec

**NOTE**

**NOTE**

This feature is intended to ensure that the highway beacons continue to warn motorists after the train clears the crossing and the warning devices have gone off. The time set here should cover time required for traffic stopped at the crossing to resume speed.

**4.2.1.10 Program Island Delay Time (40-Amp unit only) (2TRKDSTK MCF only)**

This menu appears only when the Beacon mode is selected in the PRG 2GC/I7 menu. The menu allows cancellation of the Advance Pre-emption Timer so that island inputs will immediately activate the crossing warning devices. This feature reactivates the crossing warning devices when a train passes over a crossing and then reverses direction into the island.

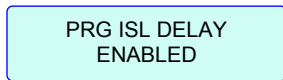

This menu may be set as Enabled or Disabled and defaults to Enabled.

**4.2.1.11 Program Stick Release Time (2TRKDSTK MCF only)**

The “Stick Release Time” function sets the Vital Stick Cancellation timer for each track when the 2TRKDSTK MCF is selected. The range is 5 to 120 minutes, in increments of 1 minute, and the default is 15 minutes. A typical example of a menu display for PROGRAM STICK RELEASE TIMER is shown below:

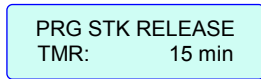

**WARNING**

**THE STICK RELEASE TIMER(S) SHOULD NOT BE SET LONGER THAN THE MINIMUM TIME BETWEEN POSSIBLE TRAIN MOVEMENTS IN OPPOSITE DIRECTIONS ON THE SAME TRACK.**



**NOTE**

Track 1 and Track 2 have independent stick release timers. The “Stick Release Time” function sets the time interval of both timers to the same value.

**4.2.1.12 Program Supplemental Island Time (SUPISL MCF only)**

The “Supplemental Island Time” function is an option for setting a timer when the SUPISL MCF is selected. The range is 5 to 20 minutes, in increments of 1 minute, and the default is 20 minutes. A typical example of a menu display for PROGRAM SUPPLEMENTAL ISLAND TIMER is shown below:



#### 4.2.1.13 Program Input 7 (40-Amp Unit Only)(2TRKDSTK MCF only)

Under the 2TRKDSTK MCF, this menu includes two additional options: TEST SWITCH and PRMT HEALTH. The PRMT HEALTH option is available only when the PRG 2GC/I7 has been set as PRE-EMPT SIM or PRE-EMPT ADV. Other options include INPUT and DISABLED.

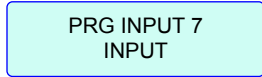

The default entry is INPUT, however, once the PRG 2GC/I7 is set as PRE-EMPT ADV or PRE-EMP SIM, it defaults to PRMT HEALTH.

When configured for Pre-empt Health, Input 7 monitors the status of the pre-empt relay and the MCF keeps the warning devices active until the Minimum Activation Time completes and pre-empt is over.

When a manual test switch is required, input 7 is used. Pressing the switch can activate crossing warning devices without going through warning release directional sticks after testing.

#### 4.2.1.14 Program Test Switch (40-Amp Unit Only)(2TRKDSTK MCF only)

This menu appears only when TEST SWITCH is selected in the PRG INPUT 7 menu described above. The two possible selections are ACTIVATE and ACT STK RELEASE.

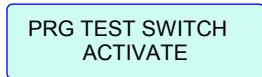

When ACTIVATE is selected, a maintainer operates a test switch to activate the crossing warning devices. If ACT STK RELEASE is selected, the crossing warning devices will activate immediately and directional sticks on both tracks will be released after two (2) seconds.



**WARNING**

**WHEN IN THE 'ACTIVATE AND STICK RELEASE' MODE, THE TEST SWITCH INPUT MUST BE DEENERGIZED FOR AT LEAST TWO (2) SECONDS IN ORDER TO RELEASE THE DIRECTIONAL STICK.**



**WARNING**

**IF SIMULTANEOUS OR ADVANCE PREEMPT IS PROGRAMMED, THE TEST SWITCH MODE DOES NOT DEENERGIZE THE PREEMPT RELAY DRIVE WHEN ACTIVATING THE WARNING DEVICES. CARE SHOULD BE TAKEN WHEN USING THE TEST SWITCH TO AVOID GATES STRIKING VEHICLES STOPPED AT THE CROSSING.**

**NOTE**

**NOTE**

The test switch will deenergize the preempt relay when used to release a “stuck” directional stick because the receding approach track circuit is deenergized.

**4.2.1.15 Program Enabled Outputs (40-Amp Unit Only)**

**WARNING**

**WARNING**

**WHEN AN OUTPUT (A OR B) IS NOT ENABLED, IT CANNOT BE USED TO CONTROL THE CROSSING LAMPS, GATES, BELLS OR TRAFFIC PRE-EMPT APPLICATION.**

A 40-amp SSCC III PLUS unit has two sets of lamp outputs, **Output A** and **Output B**. Output A includes a gate control output, bell output, and lamp outputs 1 L1 and 1 L2. Output B includes a gate control output, bell output, and lamp outputs 2 L1 and 2 L2. Each lamp output is capable of supplying 20 amps.

A 40-Amp controller unit can be programmed to operate from Output A only (20 amps lamp drive maximum), Output B output only (20 amps lamp drive maximum), or both Output A and Output B (40 amps total lamp drive).

PRG      ENABLED  
OUTPUTS: A AND B

**NOTE**

**NOTE**

The available options for this menu item are output **A**, output **B** or outputs **A AND B** (default). This menu item does not appear on the display of 20-Amp units.

**4.2.1.16 Program Time**

Time is in 24-hour format. To set the current time, the user must enter the hours (00 – 23), minutes 00 – 59) and seconds (00 – 59).

PRG      TIME:  
08:42:58 HOURS

**4.2.1.17 Program Date**

To set the current date, the user must enter the year (2000 – 2099), month (JAN – DEC) and day (01 – 31) in the format: yyyy MMM dd.

PRG      DATE:  
2002 FEB 8

After time and date have been set, they are displayed on the idle screen in the following format:

Day dd MMM yyyy  
xx:xx:xx HOURS

The “Day” of the week (**SUN** through **SAT**) as displayed above is automatically determined by the system based on the values entered.

#### 4.2.1.18 Program Daylight Saving

When the SSCC III PLUS unit is programmed to compensate for daylight savings time, the real time clock automatically adjusts for daylight saving. The options are **ENABLED** or **DISABLED**, with the default = **DISABLED**.

PRG      DAYLIGHT  
SAVING:    DISABLED

#### 4.2.1.19 Program Password

To safeguard system settings, the SSCC III PLUS is provided with password protection which can be armed (**ENABLED**) or disarmed (**DISABLED**). The unit is shipped with password protection disabled.

PRG      PASSWORD:  
              DISABLED

**NOTE**

**NOTE**

Password protection applies to the PROGRAM and CONFIGURE menus only.

If a password is established, the password can be either armed (**ENABLED**), or disarmed (**DISABLED**) until later. When password protection is enabled, the user is prompted to enter the current password whenever attempting to modify parameters from the front panel rocker switches. Password remains valid, allowing unrestricted access and editing, until menu timeout. The password must consist of four digits (**0000** through **9999**). It is recommended that the password be recorded for future reference.

**NOTE**

**NOTE**

When entering a password, to discard changes and start over before password is saved, press <EXIT>.

**NOTE**

**NOTE**

To facilitate setup, it is generally recommended that the password not be armed until all programming and configuration operations have been performed, and lamp voltages have been set up.

When password protection is disabled, the user has full modification access to the entire system.



### 4.2.1.20 Program Set to Default

The software establishes default settings for all program options. All programmed values and options can be simultaneously returned to their defaults in one simple operation, except for Date, Time and Password.

PROGRAM  
SET TO DEFAULT

**NOTE**

**NOTE**

Skip this menu item unless all default program parameters are to be restored. When default settings are restored, all default program parameters must again be setup (refer to the unit History Card for previous settings). Restoring default parameters does not affect the password settings.

When the SSCC III PLUS is set to default program values, program parameters are set as follows:

Parameter	Default Value/Option
Program Flash Rate	50 flashes per minute
Program Gates Used	YES (n/a for BASIC MCF)
Program Gate Delay 1 Timer	4 seconds
Program Gate Delay 2 Timer	4 seconds
Program Gate Rising Bell	On
Program 2GC/I7	NORMAL for all MCFs except DAXPRMT MCF = PRE-EMPT A, and PRG 2GC/I7 not configurable for BASIC MCF)
Advance Pre-empt Time	1 second (n/a for BASIC MCF)
Minimum Activation Time	20 seconds (all MCFs except BASIC); BASIC MCF is zero (0)
Program Enabled Inputs	1 through 7 (BASIC MCF only)
Program Input x	ENABLED (where x is MCF-dependent; n/a for BASIC MCF)
Program Enabled Outputs	A and B (40-Amp unit only; n/a for the 20-Amp unit)
Program Time	(not changed when set to default)
Program Date	(not changed when set to default)
Program Daylight Saving	Disabled
Program Password	(n/a - see note below)

**NOTE**

**NOTE**

Restoring default parameters does not affect the current password or the time and date settings. Password Enabled/Disabled and the 4-digit password remain as set up previously.

#### 4.2.1.21 Exit Program Mode

The “EXIT PROGRAM” menu selection allows the user to exit the Program option and return to the main menu.



**NOTE**

**NOTE**

Pressing the <EXIT> button at any time also exits the selected option and returns to the next higher level in the menu system.

#### 4.2.2 CONFIGURE Menu

The Configure menu is used for establishing certain system configuration parameters via different MCFs selected. It also provides other parameters such as timers, I/O, thresholds, etc. See figures 4-11 through 4-28 at the end of this section for Configure and Program menus.

**NOTE**

**NOTE**

Whenever the password function is enabled and a valid password has not been recently entered, the user will be prompted to enter the correct password before configuration parameters can be changed.

**NOTE**

**NOTE**

Several menu items are not visible if the unit is in “Out of Service” mode.

When any changes are made (in Configure edit mode), changes are saved when the user presses <Enter>, and a “saving changes” message is displayed.

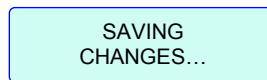

**NOTE**

**NOTE**

The Configure submenus are very similar for different MCFs, but the menu for setting the input LOS depends on the MCF selected in the crossing controller.

### 4.2.2.1 Configure Loss-Of-Shunt Timers For Each Input

In special applications, the crossing activation inputs to the SSCC III PLUS can be programmed for Loss-Of-Shunt (LOS) pickup delay.

CFG INPUT 1 LOS  
TMR: 2 sec

For example, LOS pickup delay might be useful to add some additional delay time for island circuit pickup or when track circuits are used as inputs to the SSCC III PLUS. The LOS time is the delay from the time the input energizes to when the logic considers the input valid.

The activation inputs configurable for LOS and the default settings for LOS depend on the particular MCF loaded (table 4-3).

**Table 4-3. Activation Inputs Configurable for LOS Based on Selected MCF**

LOS Configurable for Input #	MCF NAME									
	BASIC	BASICPLS	3TRK1WRP	2TRK2WRP	2TRKDSTK	SUPISL	3TRK2TRN	2TRK2TRN	DAXPRMT	(reserved)
1	Y	Y	N	N	Y	N	N	N	N	-
2	Y	Y	Y	Y	Y	N	N	N	N	-
3	Y	Y	N	Y	Y	Y	N	Y	N	-
4	Y	Y	Y	N	Y	N	N	N	N	-
5	Y	Y	N	Y	Y	N	N	N	N	-
6	Y	Y	Y	Y	Y	Y	N	Y	N	-
7	Y	Y	Y	Y	Y	Y	Y	Y	N	-

NOTE: Y = Configurable, N = Not configurable.

A separate time delay can be provided for each crossing control activation input (#1 through #7) that has been enabled in Program menu (inputs configurable depend on the MCF loaded). The range is 0 to 20 seconds, and the default value depends on the MCF loaded (refer to table 4-3).

**NOTE**

**NOTE** Only specific inputs, as determined by the MCF that is selected, can be configured for a Loss-Of-Shunt timer. Crossing control activation input #8 (GP) can never be configured for a Loss-Of-Shunt timer.

### 4.2.2.2 Configure MCF

Multiple MCFs are contained in the SSCC III PLUS. Each MCF can be selected in the field without requiring a laptop PC. Currently, each MCF has an exact name, such as BASIC, BASICPLS, 3TRK1WRP, etc. The basic crossing configuration is currently designated as BASIC.

```
CFG          : N
basic.mcf.H
```

Refer to Section 3 and Appendix B for information on the different MCFs.



**WARNING**

**IT IS NECESSARY TO SELECT THE PROPER MCF FILE PRIOR TO PROGRAMMING ANY STEPS IN THE PROGRAM MENU AND THE MCF MUST CORRESPOND WITH THE CROSSING WIRING. FAILURE TO DO SO MAY CAUSE THE CROSSING NOT TO ACTIVATE.**

**IF THE SELECTED MCF IS CHANGED, ALL PARAMETERS NEED TO BE RE-ENTERED/ RECHECKED.**



**WARNING**

**UNTIL A VALID MCF IS COMPLETELY LOADED, THE SSCC III PLUS REMAINS IN THE RESTRICTIVE STATE (CROSSING GATES DOWN, LAMPS FLASHING, AND BELLS RINGING).**

**PROVIDE FOR AN ALTERNATIVE MEANS OF ACTIVELY WARNING HIGHWAY USERS OF APPROACHING TRAINS, WHICH COMPLIES WITH REGULATIONS AND RAILROAD PROCEDURES, WHEN THE SSCC III PLUS HAS AN INPUT TAKEN OUT OF SERVICE.**

After a new MCF is selected, the SSCC III PLUS reboots, temporarily displaying the “rebooting” message.

```
REBOOTING TO
LOAD NEW MCF
```

This process takes approximately 20 seconds to complete.

**WARNING**

**WARNING**

MCF NAME, MCF CRC, AND MCF ID MUST BE VALID. REFER TO SECTION 3, TABLE 3-1, AND THE MCF RELEASE DATA SHEET IN APPENDIX A.

**WARNING**

**WARNING**

AFTER SELECTING OR CHANGING AN MCF, A FULL OPERATIONAL TEST OF THE WARNING SYSTEM MUST BE PERFORMED.

**WARNING**

**WARNING**

TO ENSURE PROPER SSCC III PLUS OPERATION, VERIFY THAT THE CORRECT MCF IS INSTALLED. ALSO VERIFY THAT ALL MENU ITEMS HAVE BEEN CORRECTLY PROGRAMMED.

#### 4.2.2.3 Configure ATCS Address

An ATCS address (site identification number) can be programmed into the system to allow for a non-vital communication link when external communication is required (refer to Section 8).

CFG ATCS ADDRESS  
 700000000000

The range is 700000000000 through 799999999999, and the default ATCS address is 700000000000 (inactive address).

The ATCS address is formatted as follows: **7.RRR.LLL.GGG.SS**

Where:

**7** is the designation for ATCS wayside type addressing,

**RRR** is the Railroad number,

**LLL** is the Line number,

**GGG** is the Group number,

**SS** is the Subnode number.

**NOTE**

**NOTE**

To establish communications, the subnode number must be 03 or greater.

#### 4.2.2.4 Configure Low Battery

The SSCC III PLUS unit monitors the system battery voltage, and can be programmed to signal when battery voltage has dropped below a set value (flashes a message on the SSCC III PLUS unit display and deactivates the MAINT CALL output). This can indicate when a battery or a battery charger has failed, or if there has been a prolonged power failure.

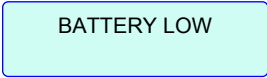

The low battery voltage adjustment varies from 9.0 to 15.0 volts in 0.1 volt steps, or can be disabled.

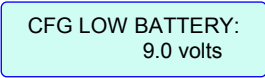
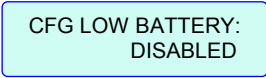

#### 4.2.2.5 Configure Aux. I/O

Interface connector J2, pin 7 may have one of three functions which can be selected by using the Program menu option CFG AUX I/O.



The default option is **NONVITAL OUTPUT** which functions as a non-vital output as established in the system MCF. This I/O can also be programmed as a **FLASH SYNC OUT** which provides a master sync output to synchronize the flashing of one or more slave crossing controllers, or as a **FLASH SYNC IN** to synchronize the unit's lamp flashing of a slave unit to a master crossing controller. Refer to figure 4-2 for a typical Master/Slave application.

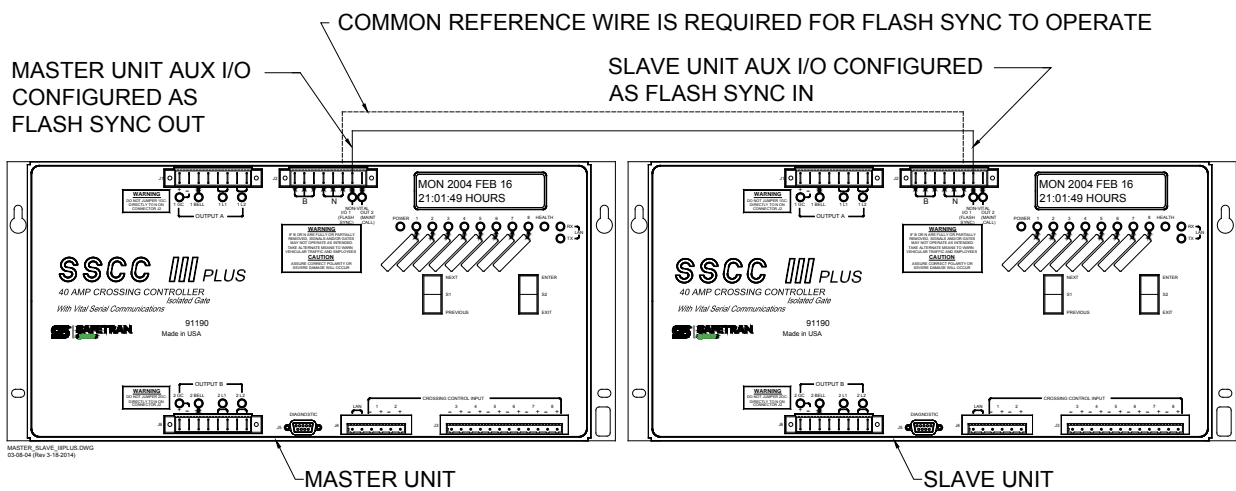

**Figure 4-2. Typical Master/Slave Application**

In figure 4-2, the common reference wire is required only if the crossing controllers are powered by separated batteries that are isolated from each other. If the battery isolation must be

maintained, a fast acting non-vital relay controlled by the master flash sync may be used to key B of the slave unit into the slave flash sync input.

**NOTE**

**NOTE**

Railroad-specific MCFs may be custom ordered. Contact Siemens Rail Automation Technical Support for more information.

#### 4.2.2.6 Configure Detect Lamp Neutral Wire

**NOTE**

**NOTE**

The power supplies in many LED signals adversely affect the Open Lamp Neutral circuitry. Disable (set to NO) DETECT LAMP NEUTRAL WIRE when LEDs are used on any lamp output.

When this function is enabled, the SSCC IV will detect when there is an open in the lamp neutral wire.

CFG DETECT LAMP  
NEUTRAL WIRE: YES

To enable detection of an open lamp neutral wire, select YES. To disable the function select NO. The default = YES.

#### 4.2.2.7 Configure Set To Default

The software establishes default settings for all configure options. All configure values and options can be simultaneously returned to their defaults in one simple operation.

CONFIGURE  
SET TO DEFAULT

**NOTE**

**NOTE**

Skip this menu item unless all default configure parameters are to be restored. When default settings are restored, some configuration parameters may need to be setup again (refer to the unit History Card for previous settings).

When the SSCC III PLUS is set to default configuration values, the configuration parameters are set as follows:

**Table 4-4: Default Configuration Values**

Parameter	Default Value/Option
Configure INPUT x LOS	0 (values for Input x LOS depend on the selected MCF)
Configure MCF	(not changed if set to default)
Configure ATCS Address	700000000000 (inactive address)
Configure Low Battery	DISABLED
Configure Aux. I/O	NONVITAL OUTPUT
Configure Detect Lamp Neutral Wire	YES

#### 4.2.2.8 Exit Configure Mode

The “EXIT CONFIGURE” menu selection allows the user to exit the Configure option and return to the main menu by pressing <ENTER> or <EXIT> when “EXIT CONFIGURE” is displayed.

EXIT CONFIGURE

#### **NOTE**

**NOTE**  
Pressing the <EXIT> button at any time also exits the selected option and returns to the next higher level in the menu system.

#### 4.2.3 SETUP LAMP VOLTAGES Menu

The Setup Lamp Voltages menu is shown in figure 4-3.



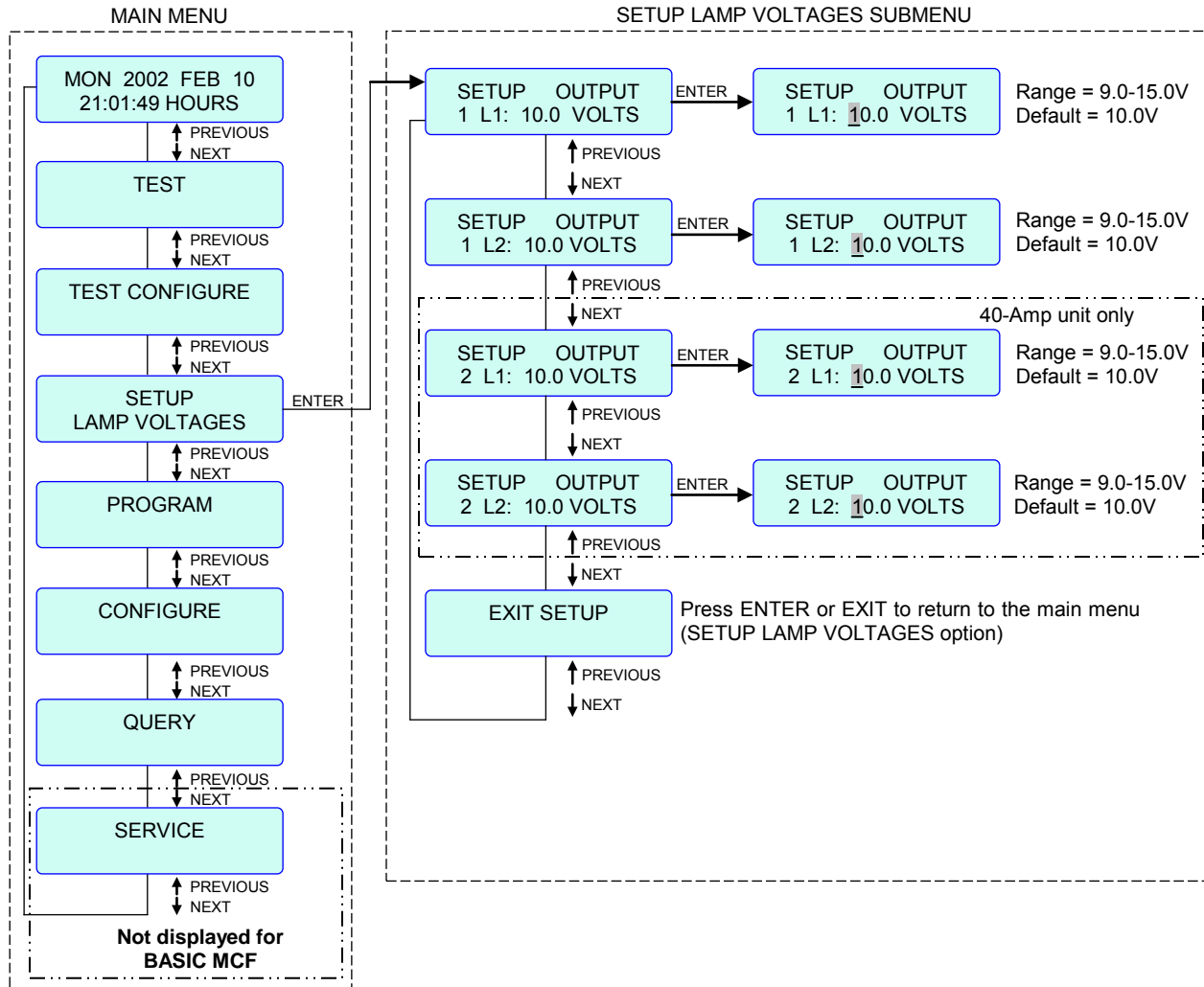

**Figure 4-3. Typical Setup Lamp Voltages Menu Flow Diagram**

The Setup Lamp Voltages menu is used for setting the flashing lamps for the proper illumination at the crossing, taking into consideration factors such as voltages drops in cables due to different lengths of cable.

When any changes are made (in Setup Lamp Voltages edit mode), changes are saved when the user presses <Enter>, and a “saving changes” message is displayed as follows:

SAVING  
CHANGES...

The factory default setting for SSCC III PLUS lamp voltage outputs is 10.0 volts (at the SSCC III PLUS output terminals). This voltage can be adjusted in the field within the range of 9.0 to 15.0 volts, however the true rms AC + DC voltage will always be no more than 1.5 volts under the supplied battery voltage.

The SSCC III PLUS provides a user-programmable, highly efficient regulated lamp voltage to minimize the chances of the lamp voltage dropping below acceptable limits when the AC power is off or when the battery charger has failed. This feature also eliminates seasonal adjustment of lamp voltages when using temperature compensated battery chargers. The regulated lamp drive is a pulse-width modulated voltage with an AC component and a DC component. A “TRUE RMS AC+DC” meter is required to accurately read the pulse-modulated lamp voltage (such as a Fluke 187 or 189 digital multimeter).

**NOTE****NOTE**

If attempting to set the L1 or L2 output voltage higher than battery voltage minus 1.5 volts, a message will continuously flash on the display as follows:

LAMP VOLTS LIMITED BY BATTERY.

**NOTE****NOTE**

Only the FAR gate (longest cable lengths) lamp voltages are set by using the Setup Output (1 L1, 1 L2, 2 L1, 2 L2) menu options. The NEAR gate (shortest cable lengths) lamp voltages are set by adjusting slide resistors on the Lighting Surge Panels.

#### 4.2.3.1 Selecting the Proper Voltmeter for Setting Lamp Voltage

To accurately read the crossing lamp voltages, a “true rms AC + DC” multimeter (e.g., Fluke 187 or 189 digital multimeter) must be used. Conventional multimeters may be used, however, the voltage read on the meter will vary from “true rms AC + DC”. The variance is not a set percentage and is dependent on battery voltage. A conversion table cross-referencing several conventional meters is provided in Section 6.

#### 4.2.3.2 Setup Output 1 L1 (Output A)

This step lights steady one of the flasher pairs of lamps and permits the SSCC III PLUS output voltage to be adjusted until the far gate lamp voltage is correct. The factory default setting for SSCC III PLUS lamp voltage outputs is 10.0 volts, however this voltage can be adjusted in the field within the range of 9.0 to 15.0 volts. Since the crossing controller unit drops 1.5 volts internally, the lamp voltage setting must be at least 1.5 volts less than the supplied battery voltage.

**NOTE****NOTE**

Both 20-Amp and 40-Amp SSCC III PLUS units have Output A.

#### **4.2.3.3 Setup Output 1 L2 (Output A)**

This step lights steady the other flasher pair of lamps and permits the SSCC III PLUS output voltage to be adjusted until the other far gate lamp voltage is correct. The factory default setting for SSCC III PLUS lamp voltage outputs is 10.0 volts, however, this voltage can be adjusted in the field within the range of 9.0 to 15.0 volts. Since the crossing controller unit drops 1.5 volts internally, the lamp voltage setting must be at least 1.5 volts less than the supplied battery voltage.

#### **4.2.3.4 Setup Output 2 L1 (Output B, 40-Amp Units Only)**

This step lights steady one of the flasher pairs of lamps and permits the SSCC III PLUS output voltage to be adjusted until the far gate lamp voltage is correct. The factory default setting for SSCC III PLUS lamp voltage outputs is 10.0 volts, however this voltage can be adjusted in the field within the range of 9.0 to 15.0 volts. Since the crossing controller unit drops 1.5 volts internally, the lamp voltage setting must be at least 1.5 volts less than the supplied battery voltage.

#### **4.2.3.5 Setup Output 2 L2 (Output B, 40-Amp Units Only)**

This step lights steady the other flasher pair of lamps and permits the SSCC III PLUS output voltage to be adjusted until the far gate lamp voltage is correct. The factory default setting for SSCC III PLUS lamp voltage outputs is 10.0 volts, however this voltage can be adjusted in the field within the range of 9.0 to 15.0 volts. Since the crossing controller unit drops 1.5 volts internally, the lamp voltage setting must be at least 1.5 volts less than the supplied battery voltage.

#### **4.2.3.6 Exit Setup Mode**

This menu selection allows the user to exit the Setup Lamp Voltages option and return to the main menu by pressing <ENTER> or <EXIT> when “EXIT SETUP” is displayed.

### 4.2.4 TEST CONFIGURE Menu

The Test Configure menu (figure 4-4) allows the user to set up (configure) timers used in the TEST menu.

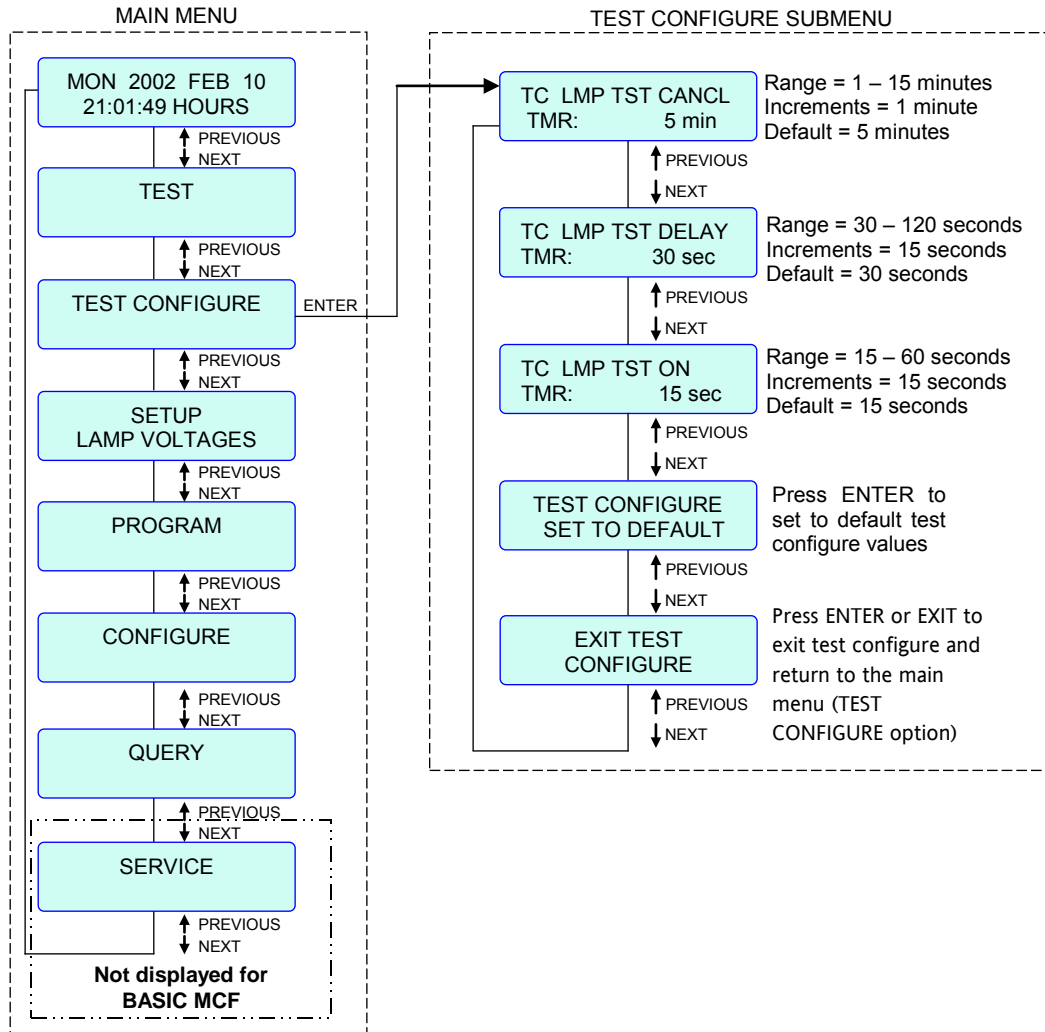
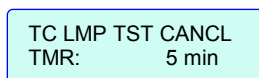

Figure 4-4. Typical Test Configure Menu Flow Diagram

#### 4.2.4.1 Test Configure Lamp Test Cancel Timer

The lamp test cancel timer is used to automatically cancel the “test lamps steady” and “test flash lamps” tests in the TEST menu, in the event the test runs too long. Normally these tests are manually terminated.



**NOTE**

**NOTE**

The “test timed lamps” and the “test timed lamps repeat” in the TEST menu do not use the lamp test cancel timer.

This timer (default = 5 minutes) is adjustable from 1 minute through 15 minutes to set the maximum test period for flashing lamps. If any of the above mentioned tests are not manually terminated within the set time frame, the system automatically terminates the test and returns to normal operation.

**4.2.4.2 Test Configure Lamp Test Delay Timer**

The **TEST TIMED LAMPS** function provides time for the Maintainer to leave the bungalow and walk to the far gate mechanism before the lights begin flashing (Lamp Test Delay time). The lights remain flashing for a programmable period of time (Lamp Test On time).

The **TEST TIMED LAMPS REPEAT** test not only gives time to arrive at the far gate to check the flashers, but provides additional time (twice the Lamp Test Delay time) to leave that location and arrive at the near gate (or an additional far gate) to check the flashers there. Both flash periods are equal to the Lamp Test On timer period.

The “lamp test delay” timer is used in conjunction with the “lamp test on” timer to provide an automatic test cycle for the **TEST TIMED LAMPS** and **TEST TIMED LAMPS REPEAT** tests in the TEST menu (refer to figure 4-5).

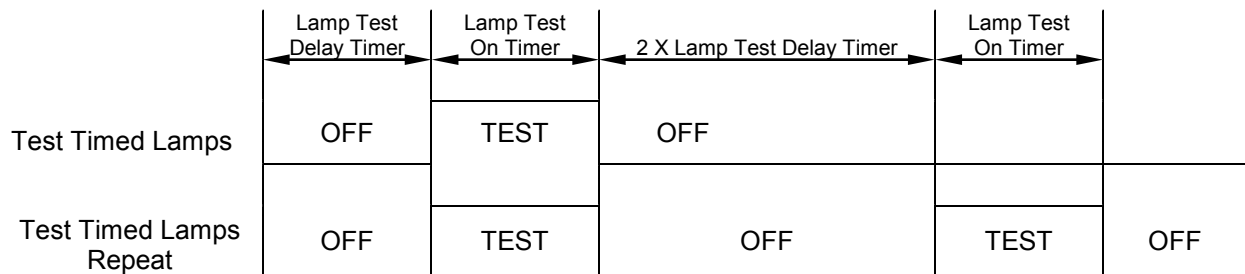

**Figure 4-5. Timed and Repeat Lamp Test Cycles**

Once set up, these two timers allow a Maintainer to initiate a **TEST TIMED LAMPS** or a **TEST TIMED LAMPS REPEAT** lamp test for verifying that all lamps are operational.

The Lamp Test Delay timer determines how long a delay time will occur before the lamps are turned on once the **TEST TIMED LAMPS** or the **TEST TIMED LAMPS REPEAT** tests are initiated.

TC LMP TST DELAY  
TMR: 30 sec

The lamp test delay timer (default = 30 seconds) is adjustable from 30 seconds through 120 seconds (in 15 second increments) to set the delay period for timed or repeat testing of the lamps.

<b>NOTE</b>	<b>NOTE</b>
	<b>TEST LAMPS STEADY</b> and <b>TEST FLASH LAMPS</b> do not use the lamp test delay timer.

#### 4.2.4.3 Test Configure Lamp Test On Timer

The “Lamp Test On” timer is used in conjunction with the “Lamp Test Delay” timer (refer to figure 4-5) to provide automatic test cycles for the **TEST TIMED LAMPS** and **TEST TIMED LAMPS REPEAT** test options in the TEST menu.

TC LMP TST ON TMR: 15 sec
------------------------------

The “Lamp Test On” timer sets how long the lights will remain on once the “Lamp Test Delay” timer has timed out and started the “Lamp Test On” timer.

<b>NOTE</b>	<b>NOTE</b>
	<b>TEST LAMPS STEADY</b> and <b>TEST FLASH LAMPS</b> do not use the lamp test on timer.

The lamp test on timer (default = 15 seconds) is adjustable from 15 seconds through 60 seconds (in 15 second increments) to set the “on” period for test flashing lamps.

#### 4.2.4.4 Test Configure Set To Default

The software establishes default settings for all test configure options. All test configure values and options can be simultaneously returned to their defaults in one simple operation.

TEST CONFIGURE SET TO DEFAULT
----------------------------------

<b>NOTE</b>	<b>NOTE</b>
	Skip this menu item unless all default test configure parameters are to be restored. When default settings are restored, all default test configure parameters may need to be set up again (refer to the unit History Card for previous settings).

When the SSCC III PLUS is set to default test configure values, the test configuration parameters are set as follows:

Parameter	Default Values
Lamp Test Cancel Timer	5 minutes
Lamp Test Delay Timer	30 seconds
Lamp Test On Timer	15 seconds

#### 4.2.4.5 Exit Test Configure Mode

This menu selection allows the user to exit the Test Configure option and return to the main menu.

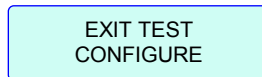

#### 4.2.5 TEST Menu

##### **NOTE**

**NOTE**

While in Test Mode, if a train approaches (XR input logic deenergizes), the test is cancelled and the crossing activates normally. When the train departs, the system remains in normal operation.

##### **WARNING**

**WARNING**

**IN THE TEST MENU “TEST ACTIVATE CROSSING” MODE, IF AN ADVANCE PRE-EMPTION CONFIGURATION IS SET, WARNING DEVICES WILL NOT ACTIVATE IMMEDIATELY WHEN A TRAIN APPROACHES UNTIL THE ADVANCE PRE-EMPT TIMER RUNS. THE 2GC OUTPUT WILL DEENERGIZE IMMEDIATELY.**

**NOTE**

**NOTE**  
 When in test mode, after 90 seconds without activity of the front panel rocker switches, the display automatically reverts to the idle screen unless performing a test. In this case, the timeout period is determined by the Lamp Test Cancel Timer in the Test Configure option (for the Test Lamps Steady or Test Flash Lamps functions), or by the Lamp Test Delay Timer and the Lamp Test On Timer (for the Test Timed Lamps and Test Timed Lamps Repeat functions).

The Test menu (figure 4-6) provides a selection of tests for checking crossing operation.

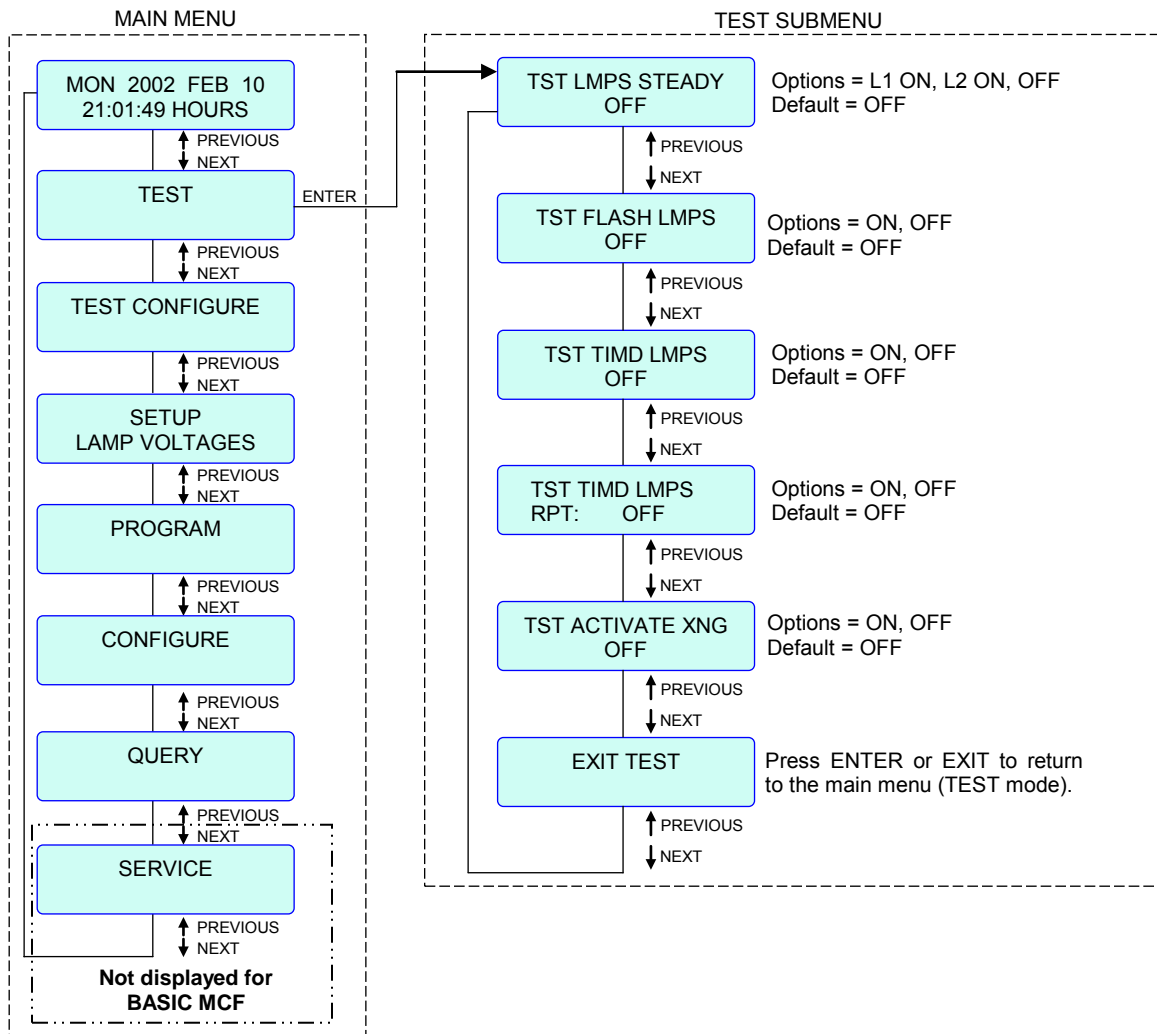

**Figure 4-6. Typical Test Menu Flow Diagram**



**NOTE****NOTE**

The default state for all test modes is **OFF**. Test modes not manually terminated are automatically terminated after a timeout period.

**4.2.5.1 Test Lamps Steady**

This is a manual test that turns on the lamp voltage to selected crossing lamps in a steady fashion for testing/adjusting lamps or setting lamp voltages. The options are OFF, L1 ON, or L2 ON; the default is OFF.

TST LMPS STEADY  
OFF

**4.2.5.2 Test Flash Lamps**

This is a manual test that turns on the lamp voltage to all crossing lamps (L1/L2) in the flashing mode for inspection or testing lamps (gates remain up). The options are OFF or ON; the default is OFF.

TST FLASH LMPS  
OFF

**4.2.5.3 Test Timed Lamps**

The Test Timed Lamps test mode is an automatic lamp flashing test. It is provided with configurable delays to make it easier for one person to perform testing and verification of the FAR lamps.

TST TIMD LMPS  
OFF

The **TEST TIMED LAMPS** function provides time for the Maintainer to leave the bungalow and walk to the far gate mechanism before the lights begin flashing (Lamp Test Delay time). The lights remain flashing for a programmable period of time (Lamp Test On time).

**TC LMP TST ON TMR**, range = 15-60 seconds, default = 15 seconds.

The **TST TIMD LMPS** option can be toggled between ON or OFF, the default is OFF.

#### 4.2.5.4 Test Timed Lamps Repeat

The **TEST TIMED LAMPS REPEAT** test mode is an automatic lamp flashing test. It is provided with configurable delays to make it easier for one person to perform testing and verification of two sets of FAR lamps.

TST TIMD LMPS  
RPT: OFF

**TST TIMD LMPS RPT: ON** means the above test (paragraph 4.2.5.3) is performed, then repeated with the second test period delayed double what is set in the Test Timed Lamps test. For example, if delay for the first test is set at 30 seconds, the second test is performed after 60 seconds.

The **TEST TIMED LAMPS REPEAT** test not only gives time to arrive at the far gate to check the flashers, but provides additional time (twice the Lamp Test Delay time) to leave that location and arrive at the near gate (or an additional far gate) to check the flashers there. Both flash periods are equal to the Lamp Test On timer period.

The **TST TIMD LMPS RPT** option can be toggled between ON or OFF, the default is OFF.

#### 4.2.5.5 Test Activate Crossing



**WARNING**

**IN THE TEST MENU “TEST ACTIVATE CROSSING” MODE, IF AN ADVANCE PRE-EMPTION CONFIGURATION IS SET, FLASHERS WILL NOT FLASH IMMEDIATELY WHEN A TRAIN APPROACHES EVEN THOUGH 2GC MAY BE SET TO DEENERGIZE IMMEDIATELY.**

This is a manual test that activates the crossing by simulating a crossing control input activation. This test is useful for checking complete operation of the system including gates, lamps, bells, and timers.

TST ACTIVATE XNG  
OFF

The options for Test Activate Crossing are ON or OFF; default is OFF.

#### 4.2.5.6 Exit Test Mode

This menu selection allows the user to exit the Test option and return to the main menu.

EXIT TEST

## 4.2.6 QUERY Menu

The Query menu provides version information for master and slave executable software, master and slave boot files, and configuration versions.

### 4.2.6.1 Query Software Versions

Refer to figure 4-7 for the Query Software Versions menu. The following software version information is available:

MEF: Master executable file  
MBT: Master boot file  
SEF1 – SEF4: Slave executable file  
SBT1 – SBT4: Slave boot file

**NOTE****NOTE**

SEF3, SEF4, SBT3, and SBT4 are displayed only for the 40-Amp unit (they do not exist for the 20-amp unit).

**NOTE****NOTE**

A password is not required to view software versions.

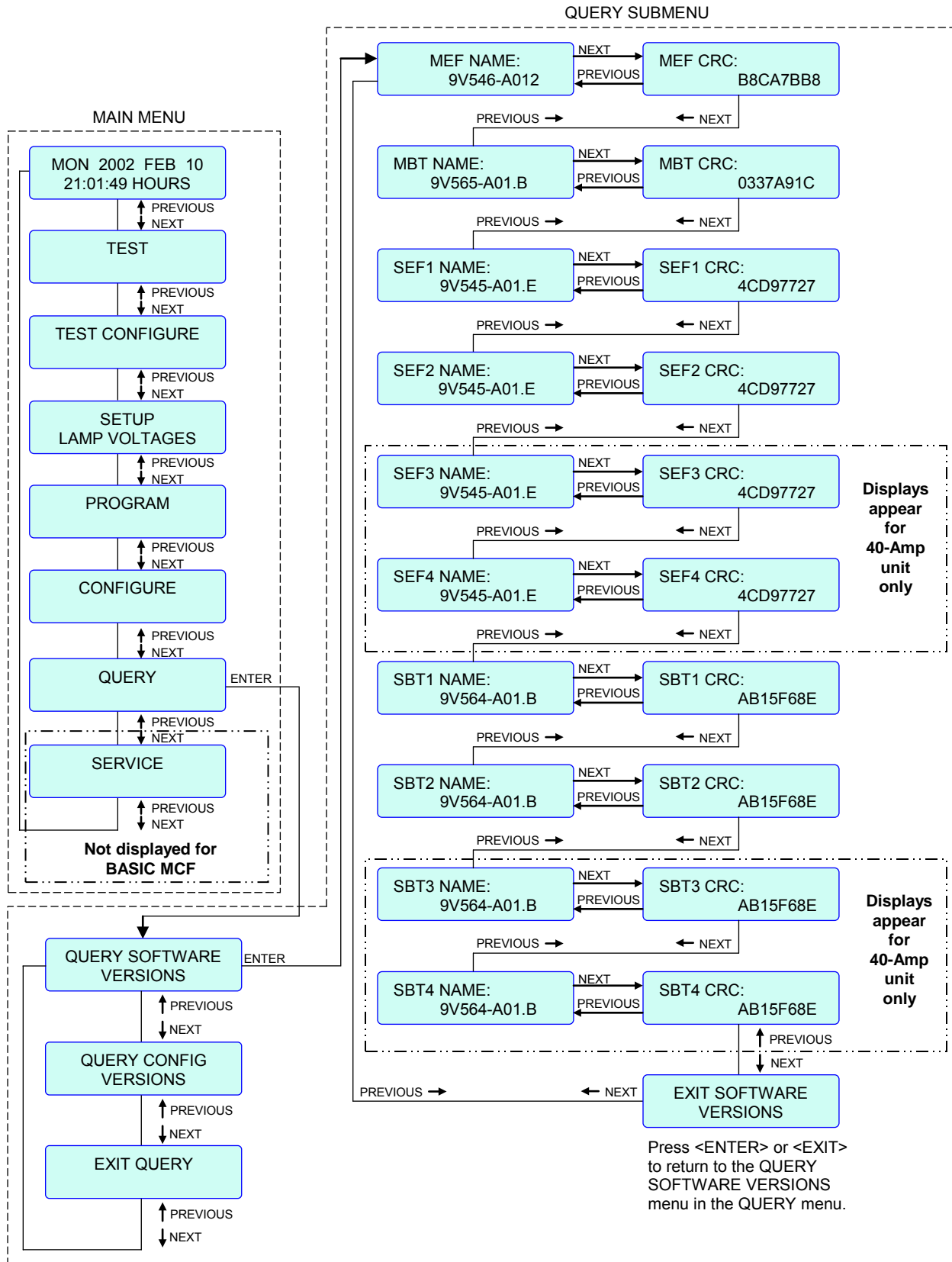

Figure 4-7. Typical Query Software Versions Menu Flow Diagram

### 4.2.6.2 Query Configuration Versions

Refer to figure 4-8 for the Query Configuration Versions menu. The following configuration version information is currently available:

- MCF NAME: Assigned MCF filename (.mcf.version extension)
- MCF CRC: 8-digit hexadecimal number calculated from the MCF
- CAPABILITY NAME: Factory assigned number

**NOTE** A password is not required to view configuration versions.

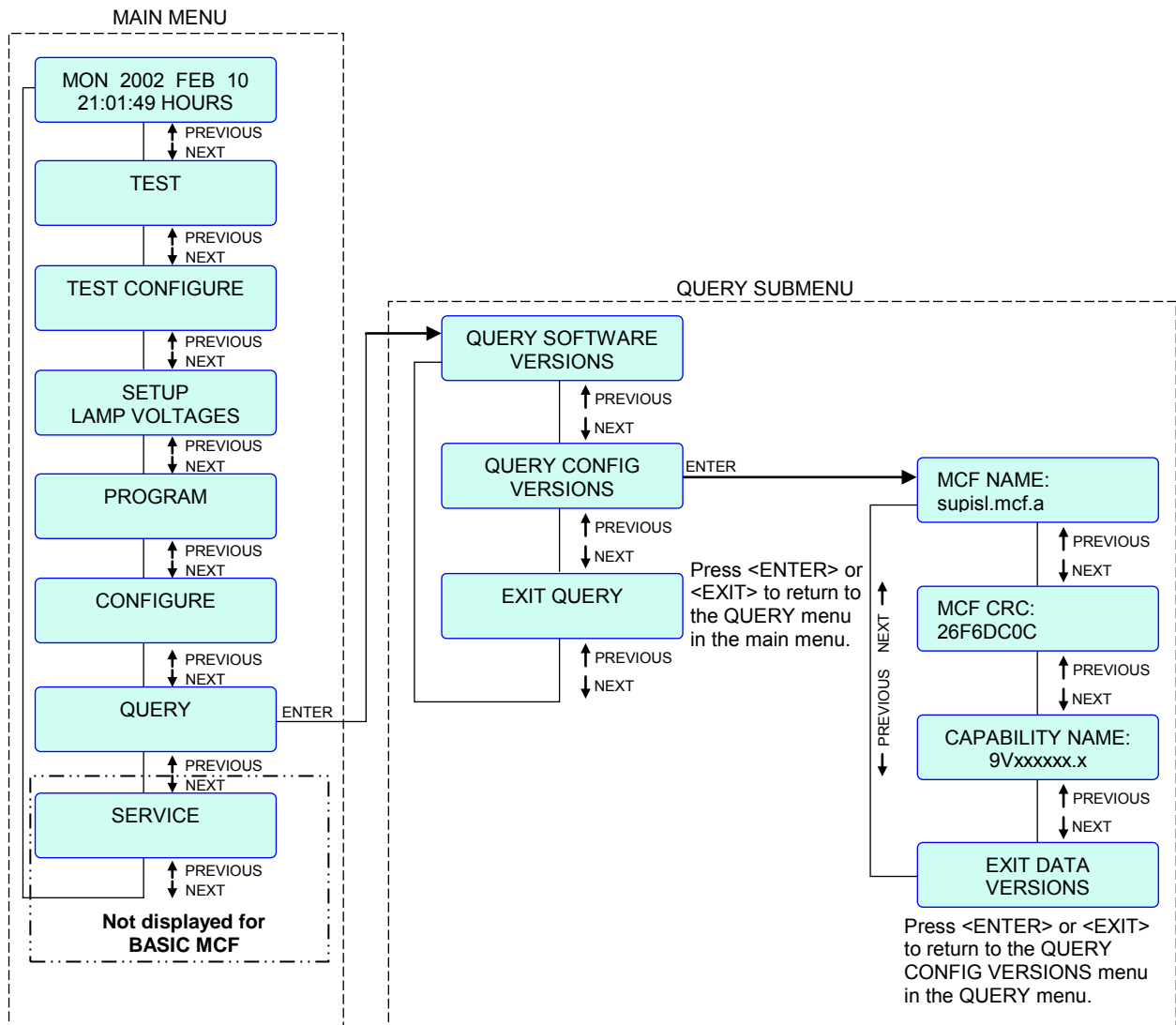

Figure 4-8. Typical Query Configuration Versions Menu Flow Diagram

#### 4.2.7 SERVICE Menu

There may be occasions when one or more configured activation inputs or the entire crossing controller must be taken out of service or disabled temporarily while maintenance is performed. The crossing controller has a feature that allows selected activation inputs to be out-of-service while the controller continues to function normally for the other in-service activation inputs. The advantage of this feature is that circuit jumpers are not used and the procedure can be recorded or alarmed with an SEARII.



**WARNING**

**PROVIDE FOR AN ALTERNATIVE MEANS OF ACTIVELY WARNING HIGHWAY USERS OF APPROACHING TRAINS, WHICH COMPLIES WITH REGULATIONS AND RAILROAD PROCEDURES, WHEN THE SSCC III PLUS HAS AN INPUT TAKEN OUT OF SERVICE.**



**WARNING**

**IF INPUT POWER IS LOST OR THE CROSSING CONTROLLER RESETS (INITIALIZATION PROCESS OCCURS) WHILE IN OUT-OF-SERVICE MODE (INDIVIDUAL INPUTS OR ENTIRE CONTROLLER OUT OF SERVICE), THE OUT-OF-SERVICE MODE IS CANCELLED.**



**NOTE**

When Out of Service mode is selected for 1 to 7 crossing activation inputs, the GP input will still activate the crossing controller, and all test modes are still functional. Also, the crossing will activate if a hardware failure occurs.



**NOTE**

When individual inputs or the entire controller is placed out of service, the MAINT CALL is turned off.

**NOTE**

**NOTE**  
 When an input (for all MCFs except BASIC MCF) is taken out of service, the logic bypasses the input (refer to figure 4-9). BASIC MCF does not have the capability to take crossing activation inputs out of service.

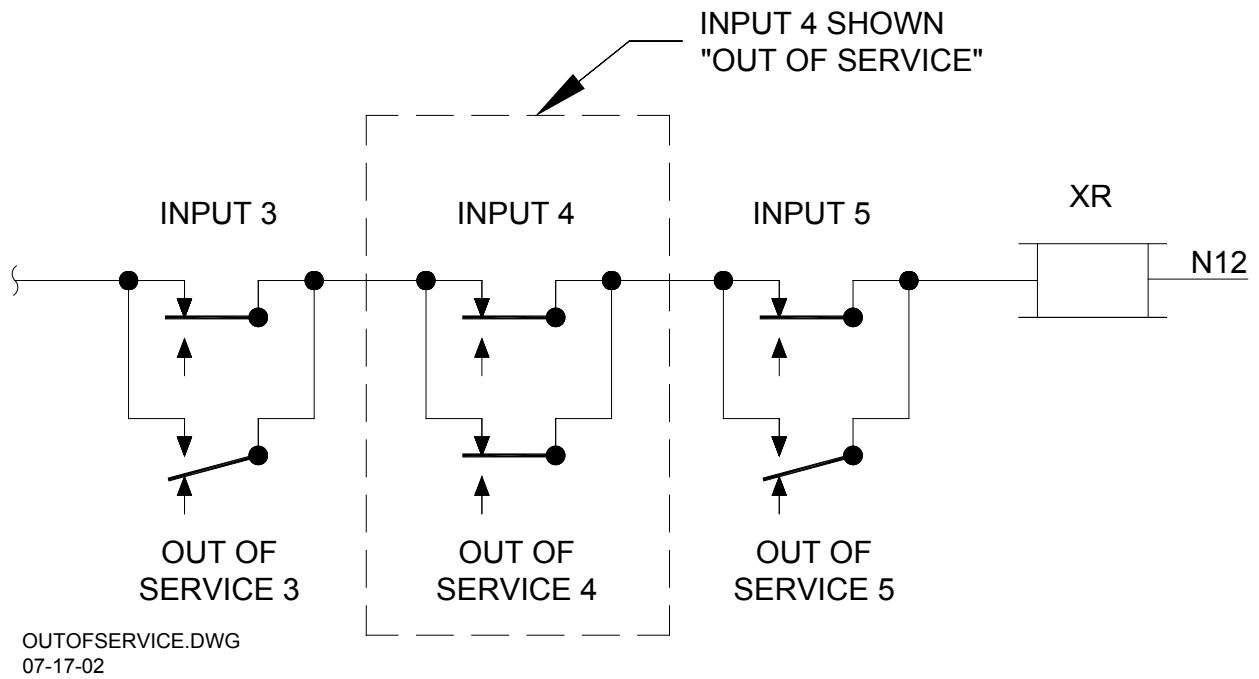

**Figure 4-9. Typical Out Of Service Input**

**NOTE**

**NOTE**  
 Several menu items are not visible if the unit is in “Out of Service” mode.

The **Service** menu (see figure 4-10) accessed from the front panel of the SSCC III PLUS allows a maintainer to quickly set inputs out of service for timed duration (1 to 24 hours) or constant duration. A track or a set of inputs may be taken out of service for all MCFs except BASIC MCF.

When inputs are out of service, the respective LEDs on the SSCC III PLUS flash to indicate that the SSCC III PLUS is not in normal operation and the **Maintenance Call** output is deenergized.

**NOTE**

**NOTE**

When **Out Of Service** mode is first accessed, a 5-minute timer is started. If the timer elapses before the Out of Service mode has been configured, the Out of Service process is cancelled and **Service** reverts to the default option (**In Service**).

The options for the **Service** menu are: “In Service” and “Out Of Service” (see example display below). The default option is “In Service”.

IN SERVICE



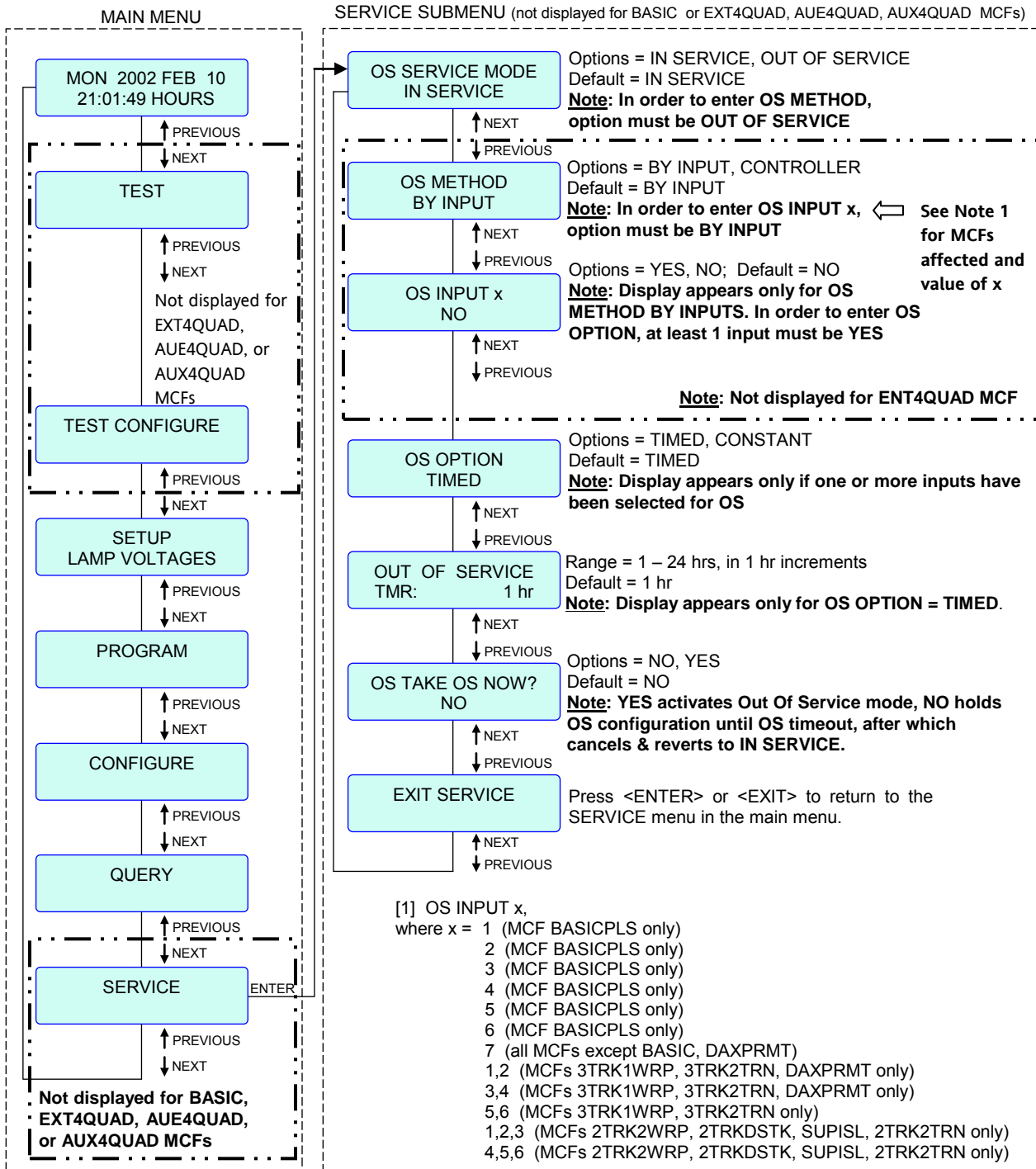

Figure 4-10. Typical Service Menu Flow Diagram

This page intentionally left blank

This page intentionally left blank |

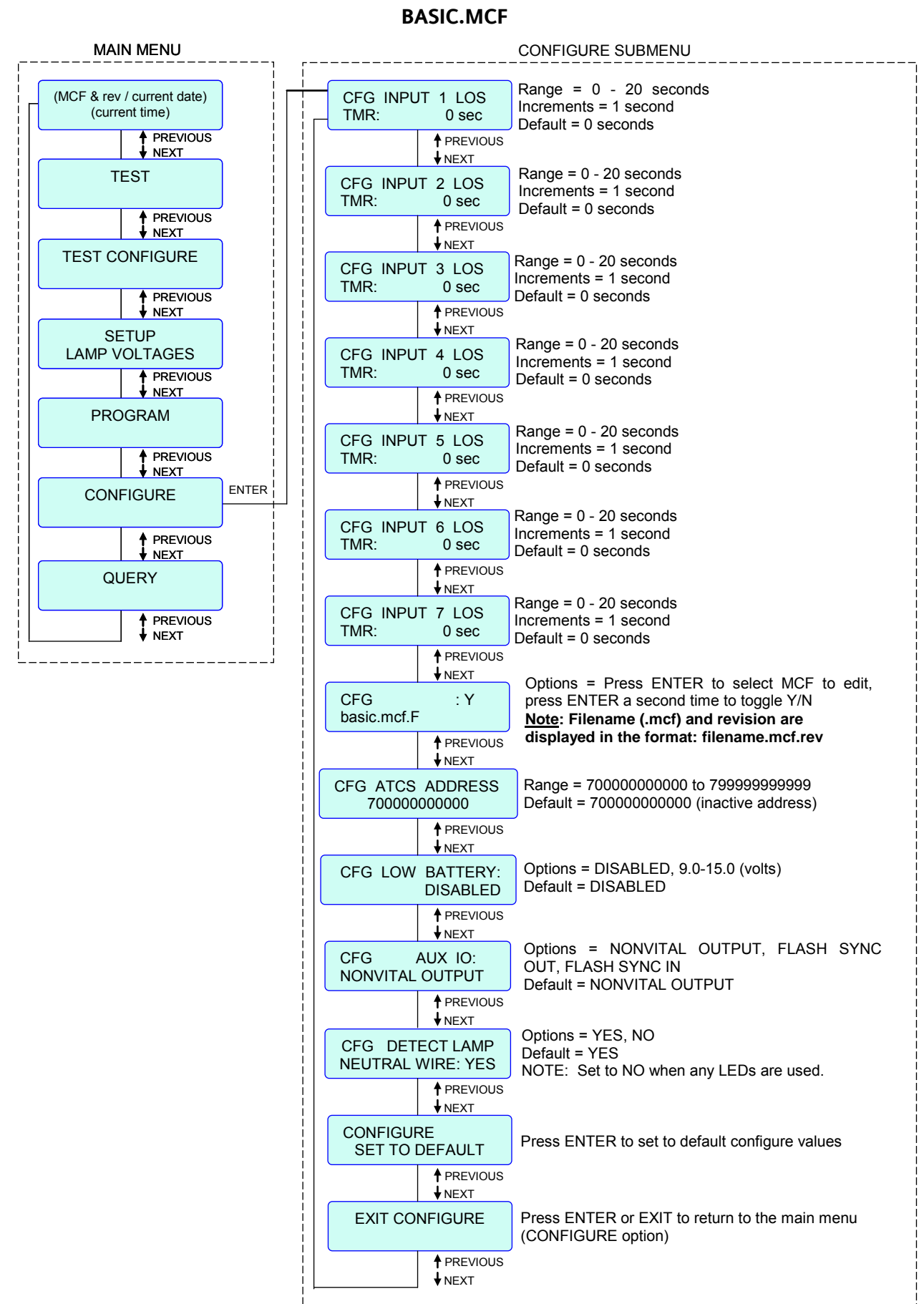

Figure 4-11. BASIC MCF Configure Menu Flow Diagram

BASIC.MCF

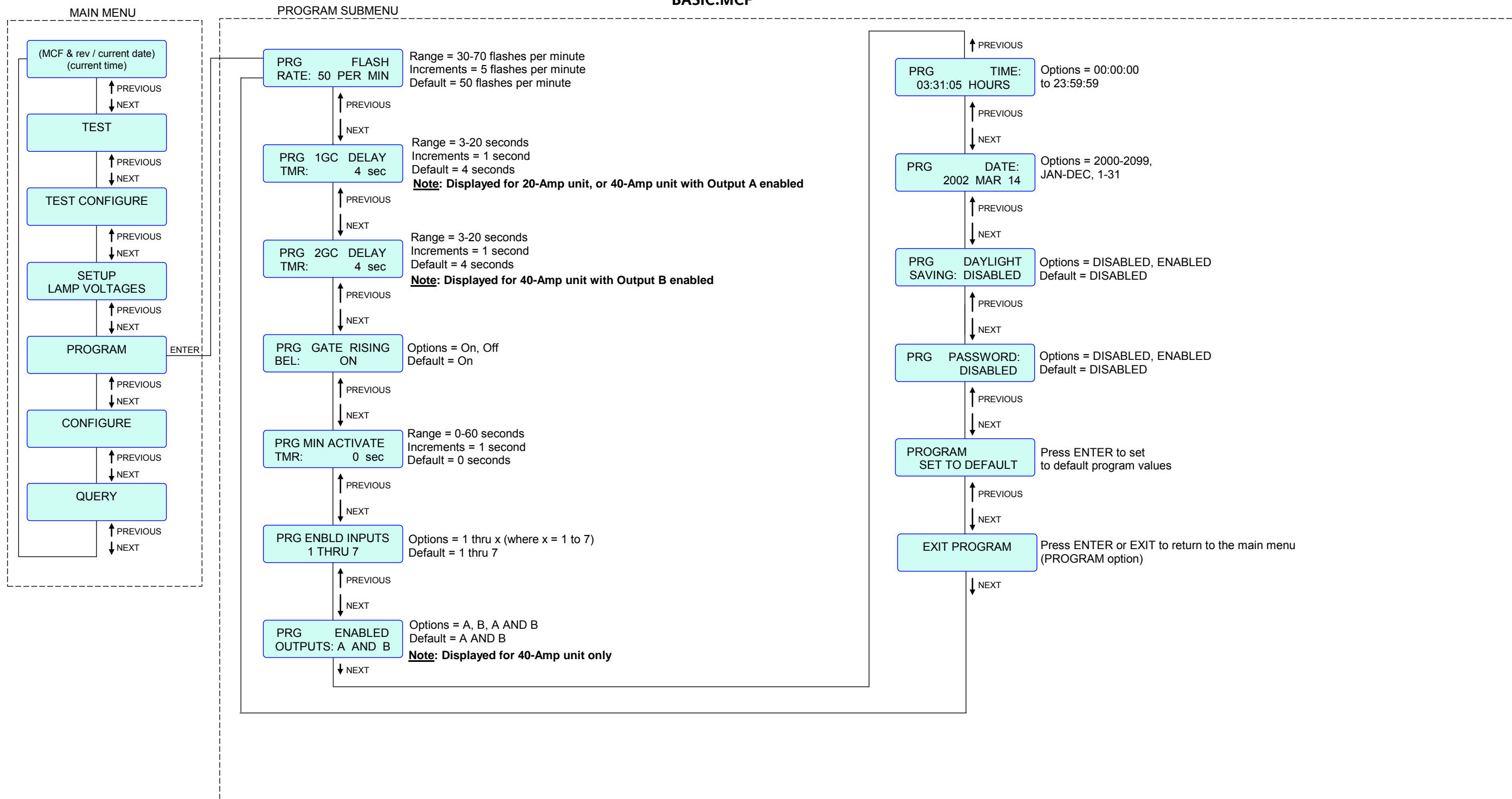

Figure 4-12. BASIC MCF Program Menu Flow Diagram

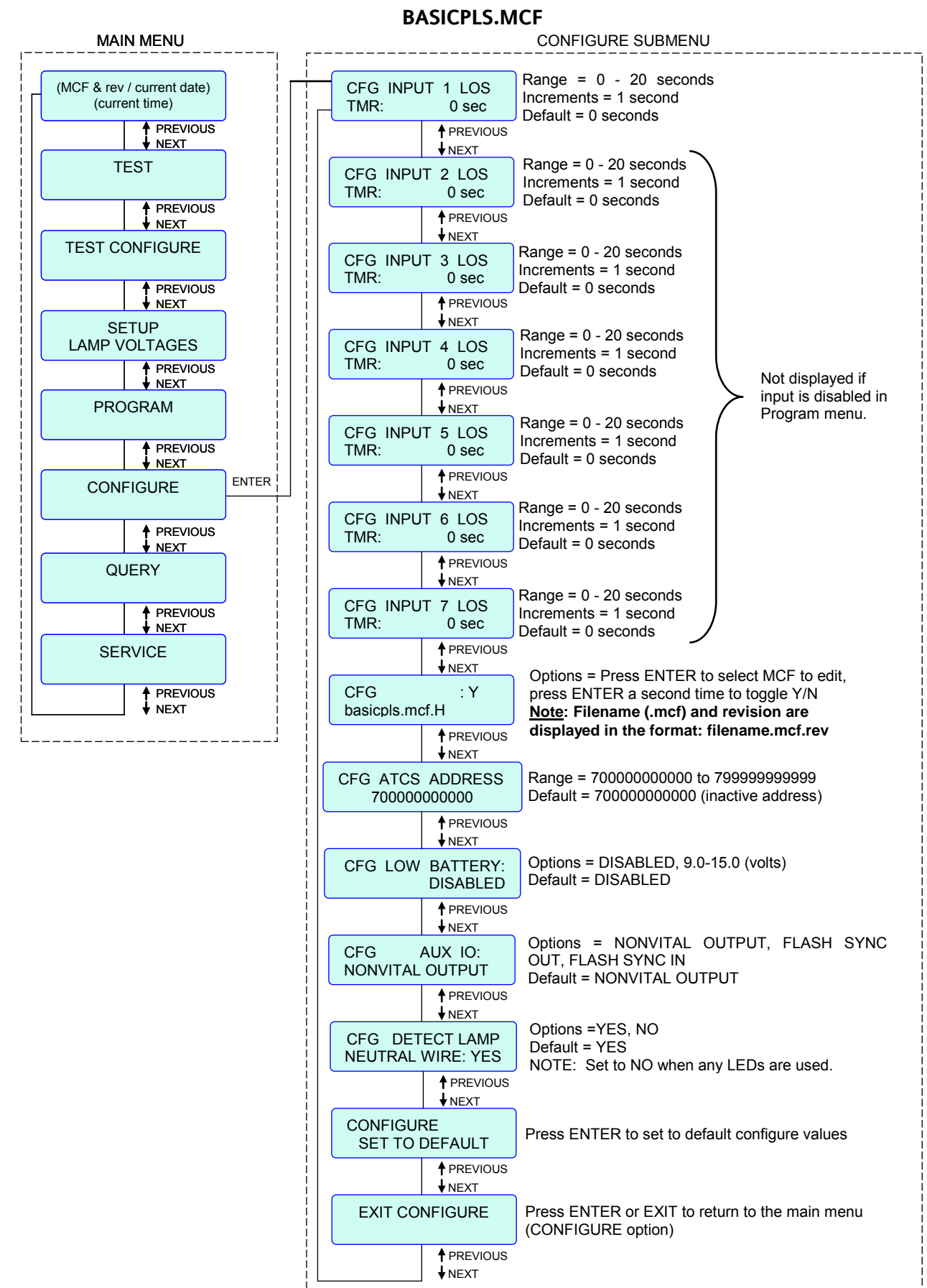

Figure 4-13. BASICPLS MCF Configure Menu Flow Diagram

BASICPLS.MCF

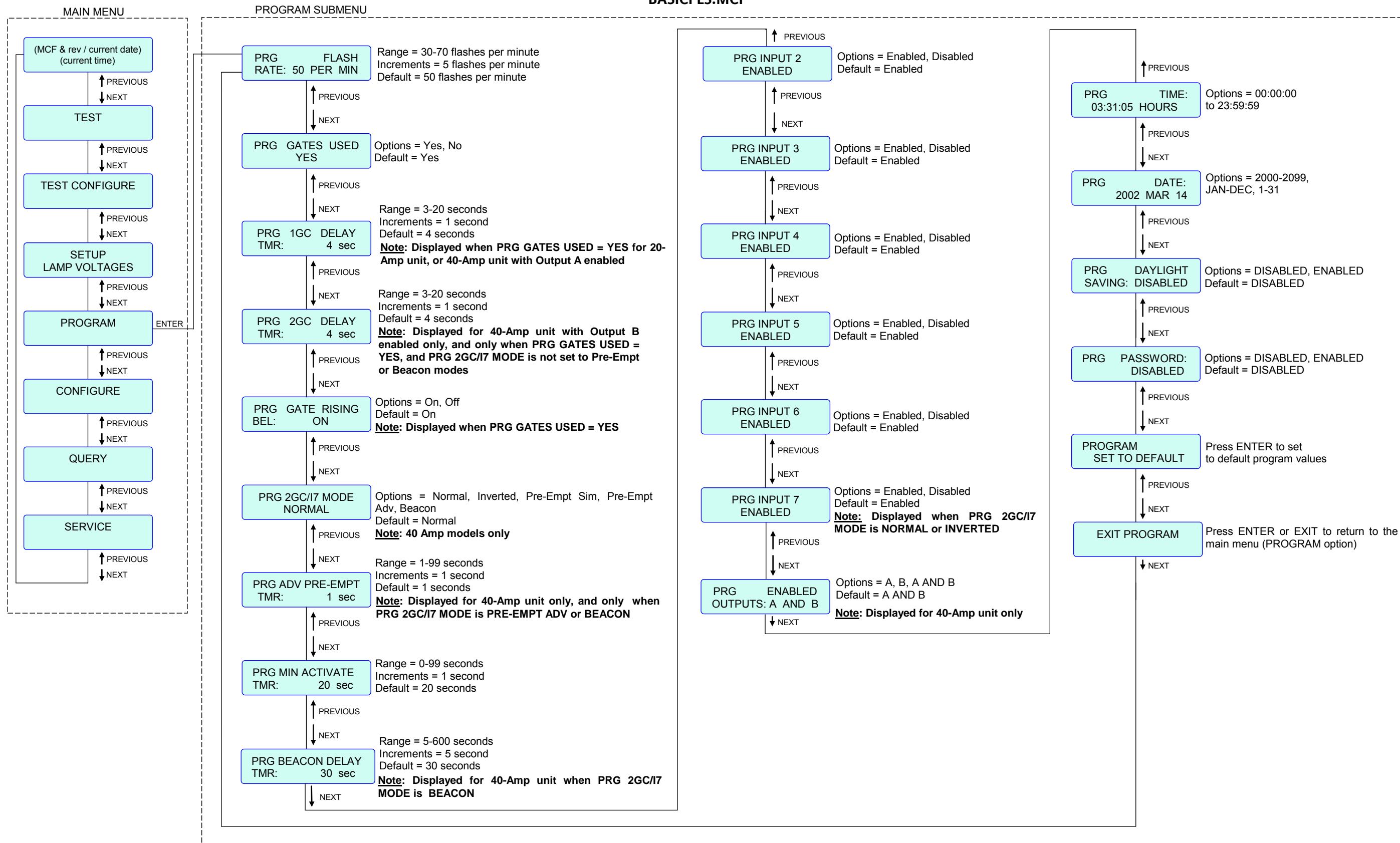

Figure 4-14. BASICPLS MCF Program Menu Flow Diagram

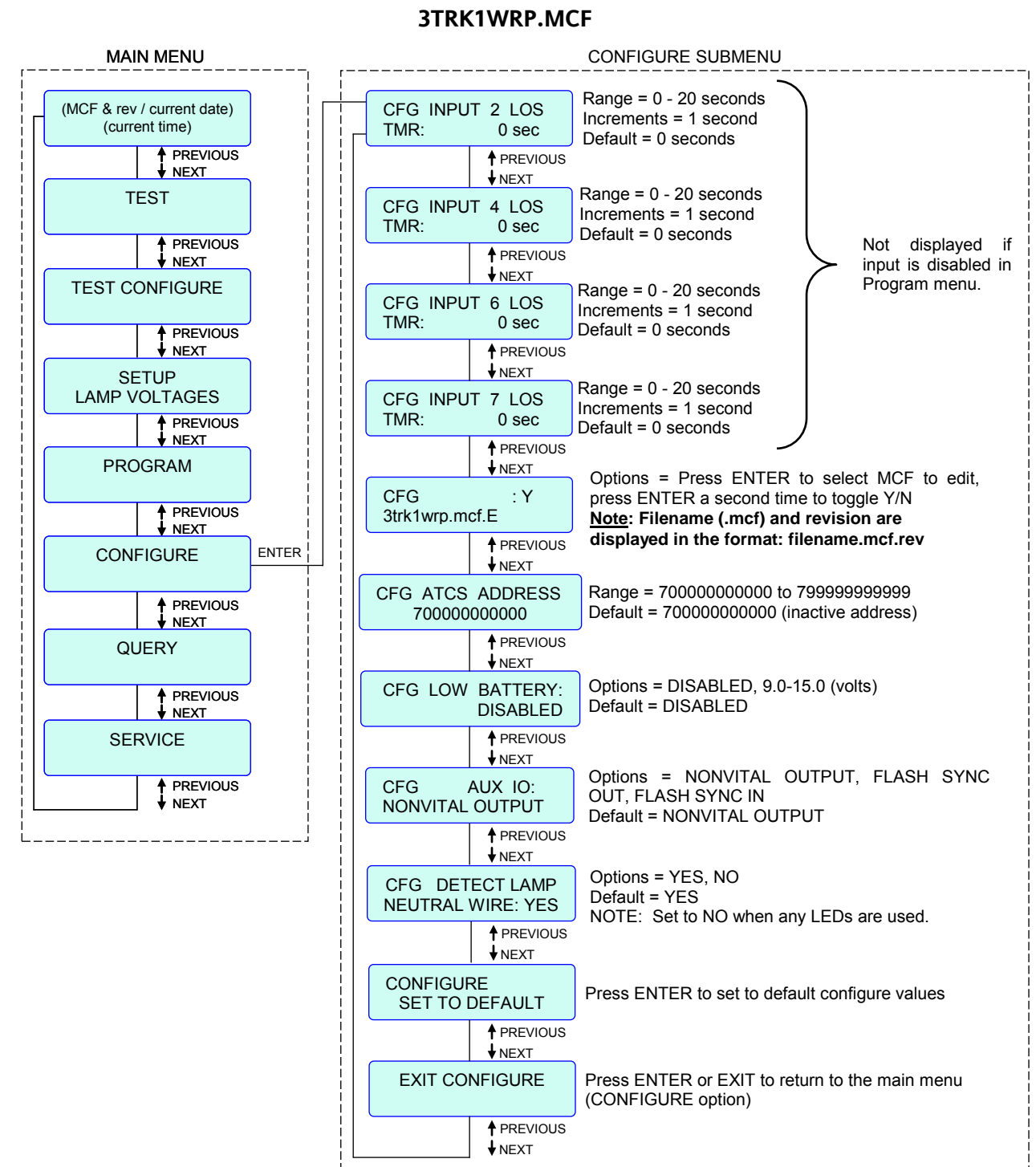

Figure 4-15. 3TRK1WRP MCF Configure Menu Flow Diagram



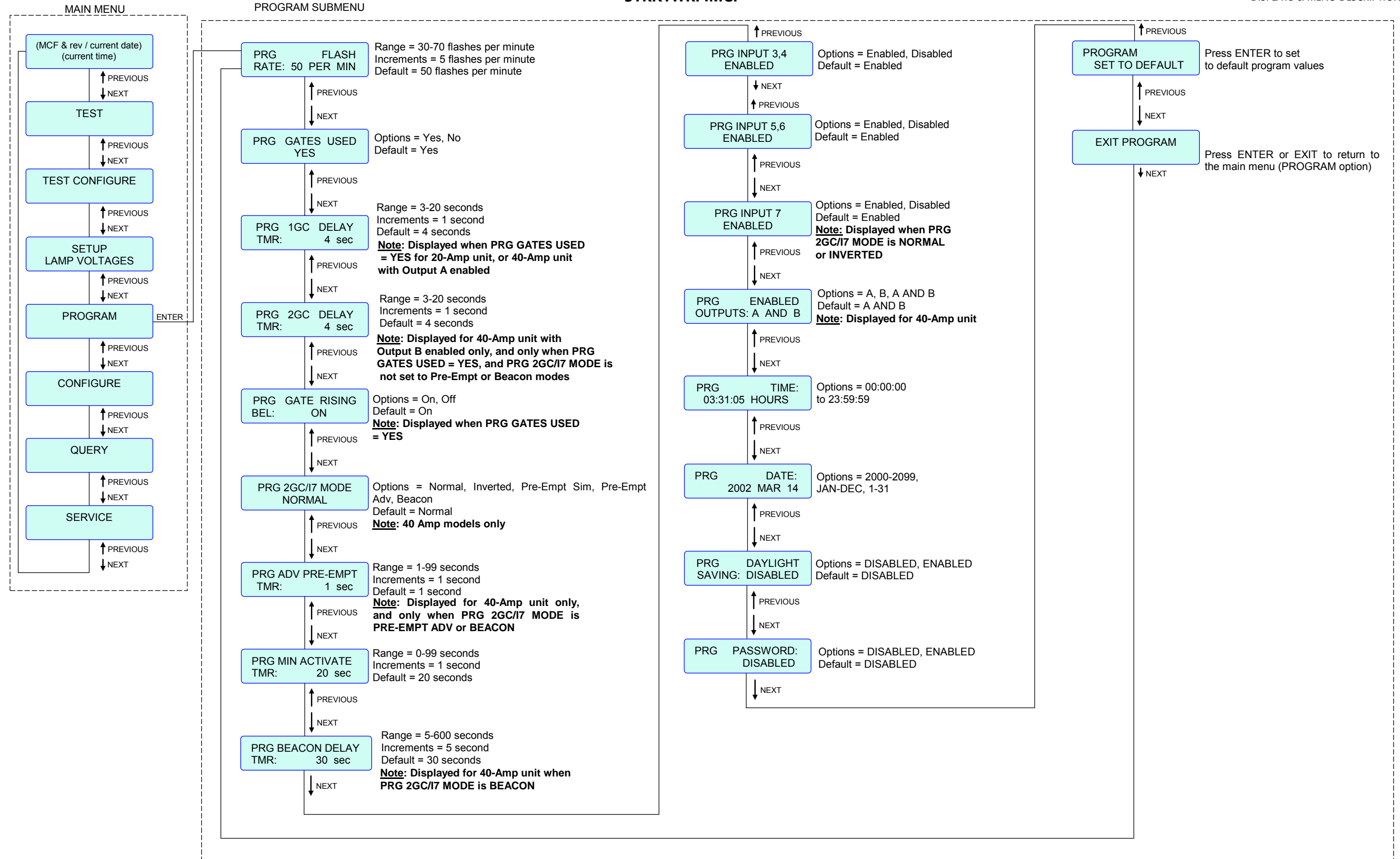
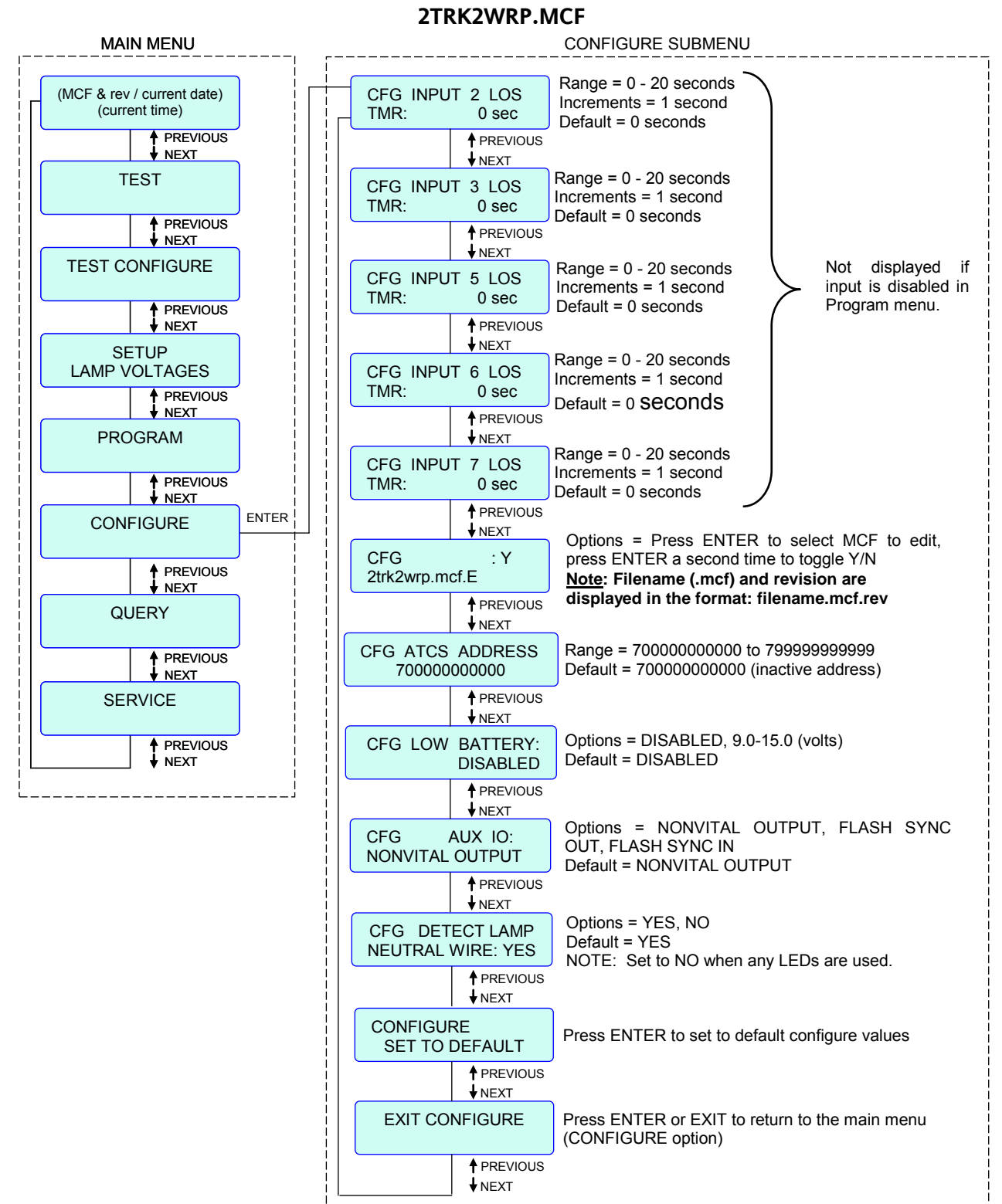

Figure 4-16. 3TRK1WRP MCF Program Menu Flow Diagram



**Figure 4-17. 2TRK2WRP MCF Configure Menu Flow Diagram**

2TRK2WRP.MCF

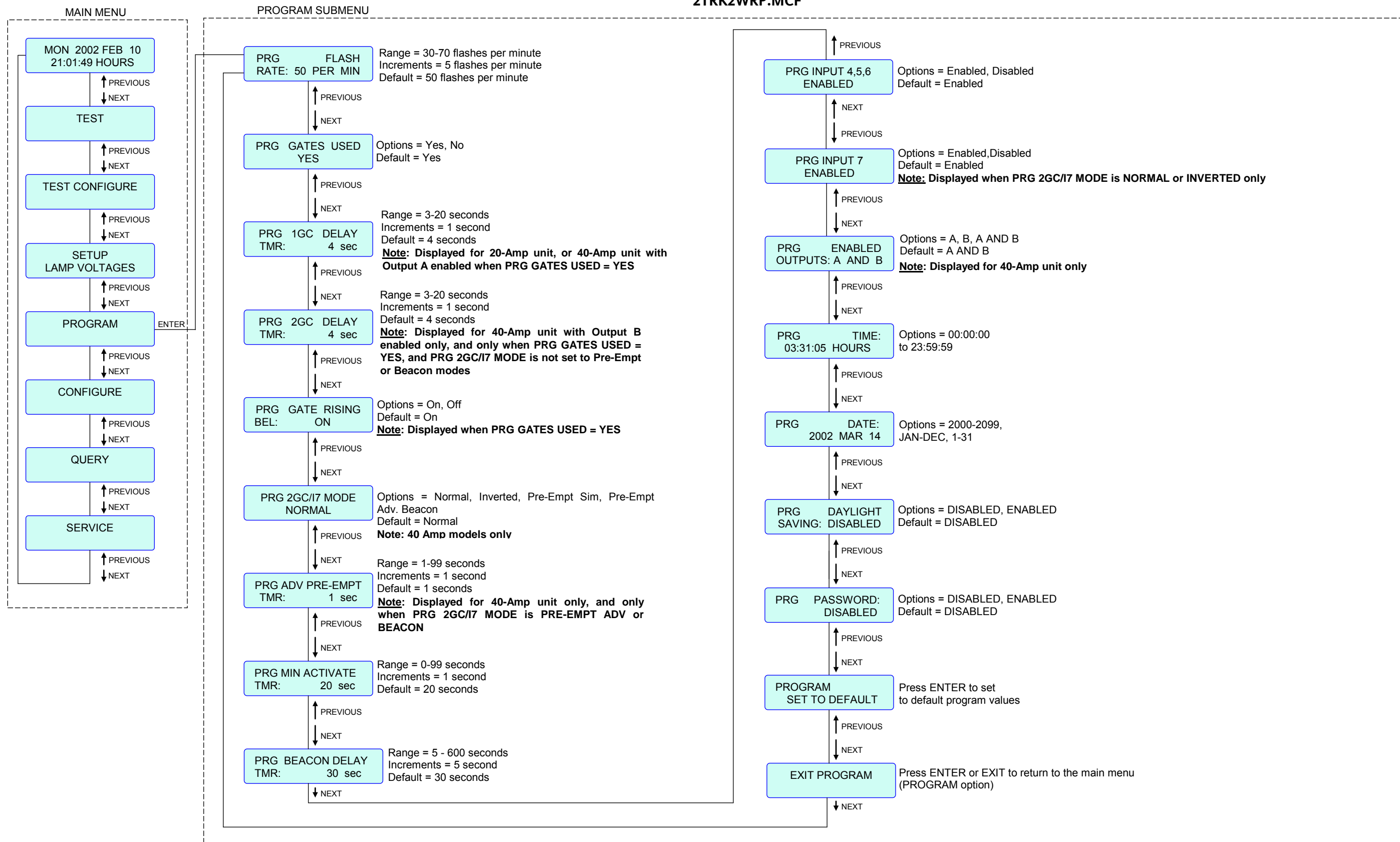
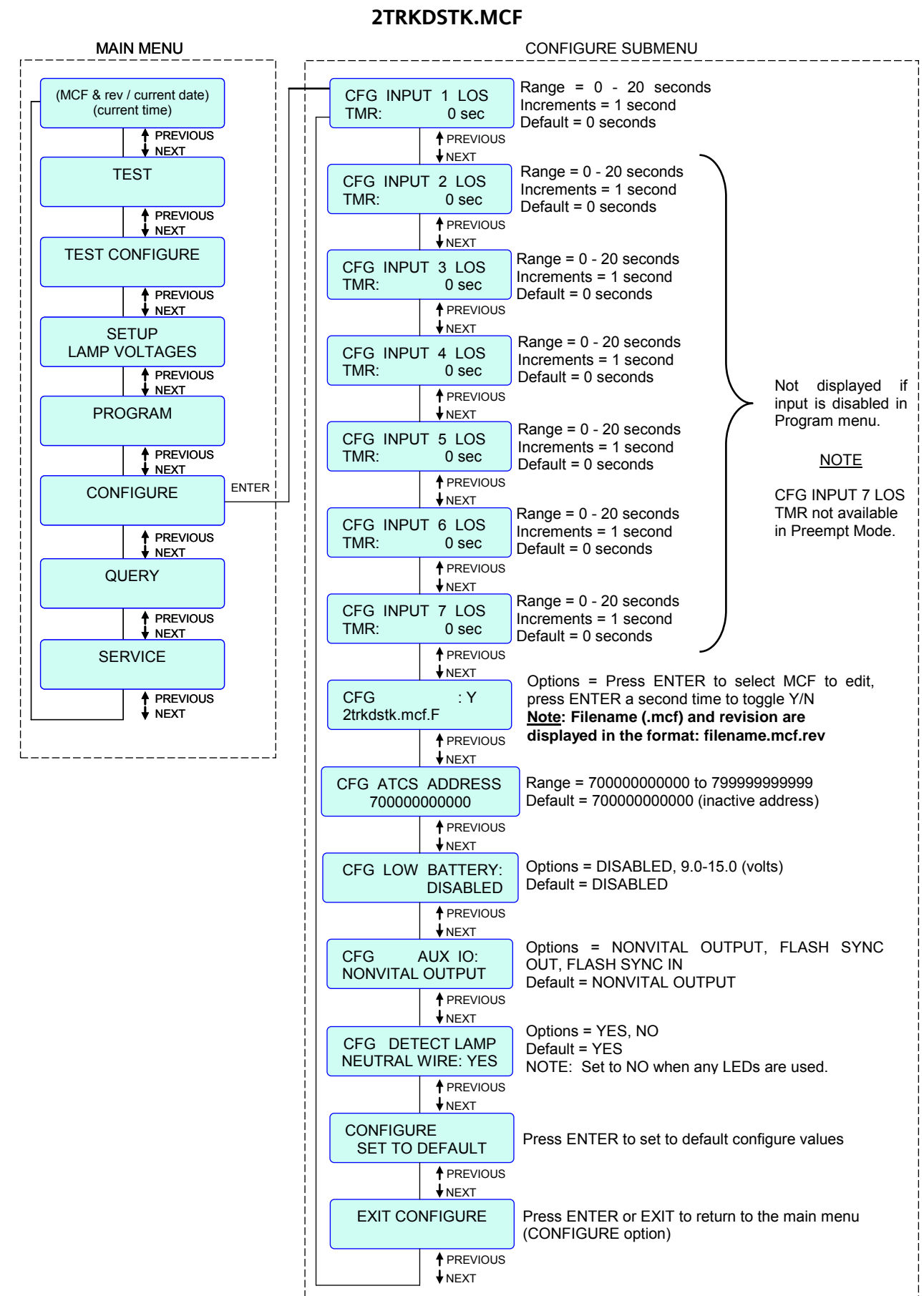

Figure 4-18. 2TRK2WRP MCF Program Menu Flow Diagram



**Figure 4-19. 2TRKDSTK MCF Configure Menu Flow Diagram**

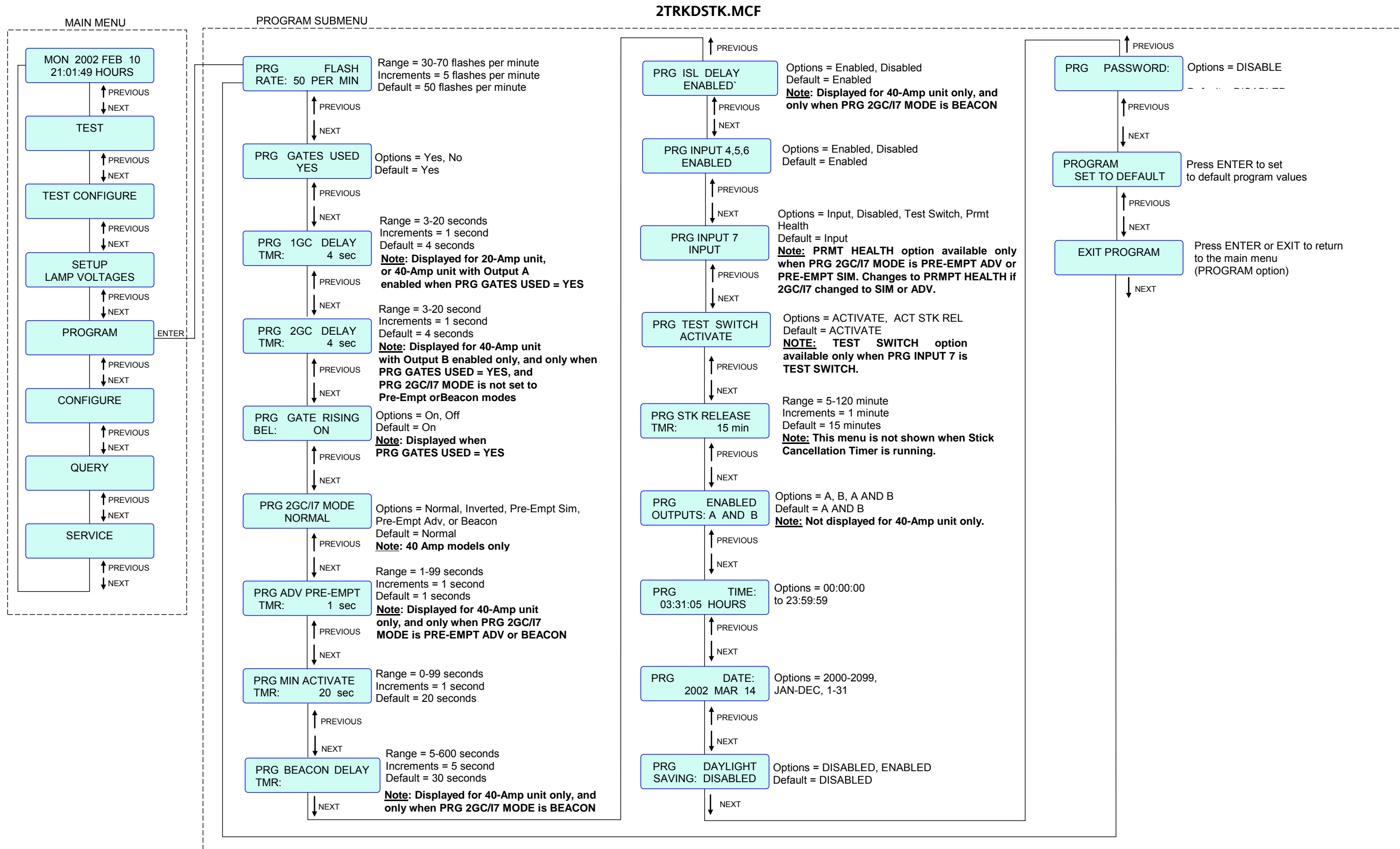
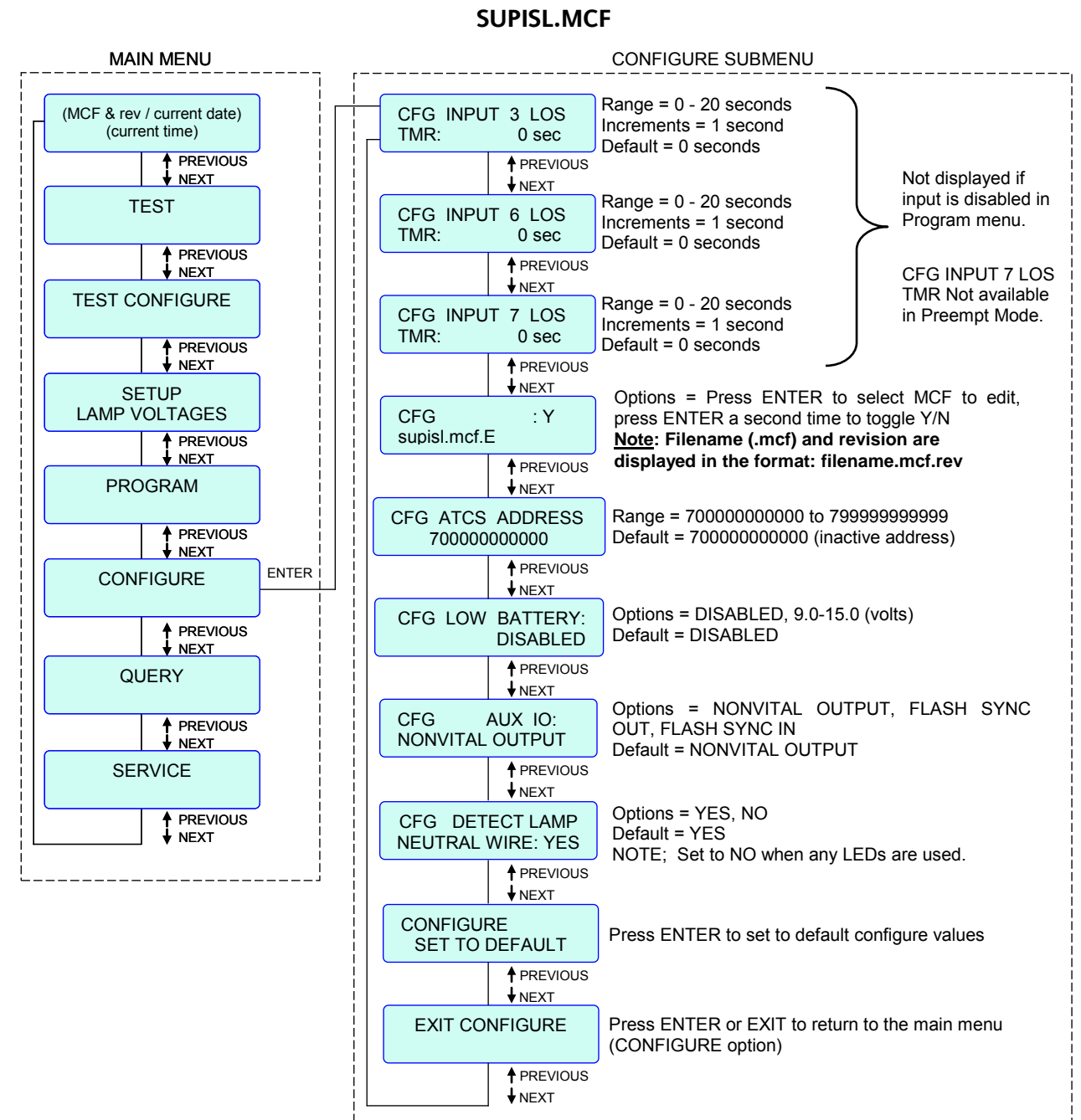

Figure 4-20. 2TRKDSTK MCF Program Menu Flow Diagram



**Figure 4-21. SUPISL MCF Configure Menu Flow Diagram**

SUPISL.MCF

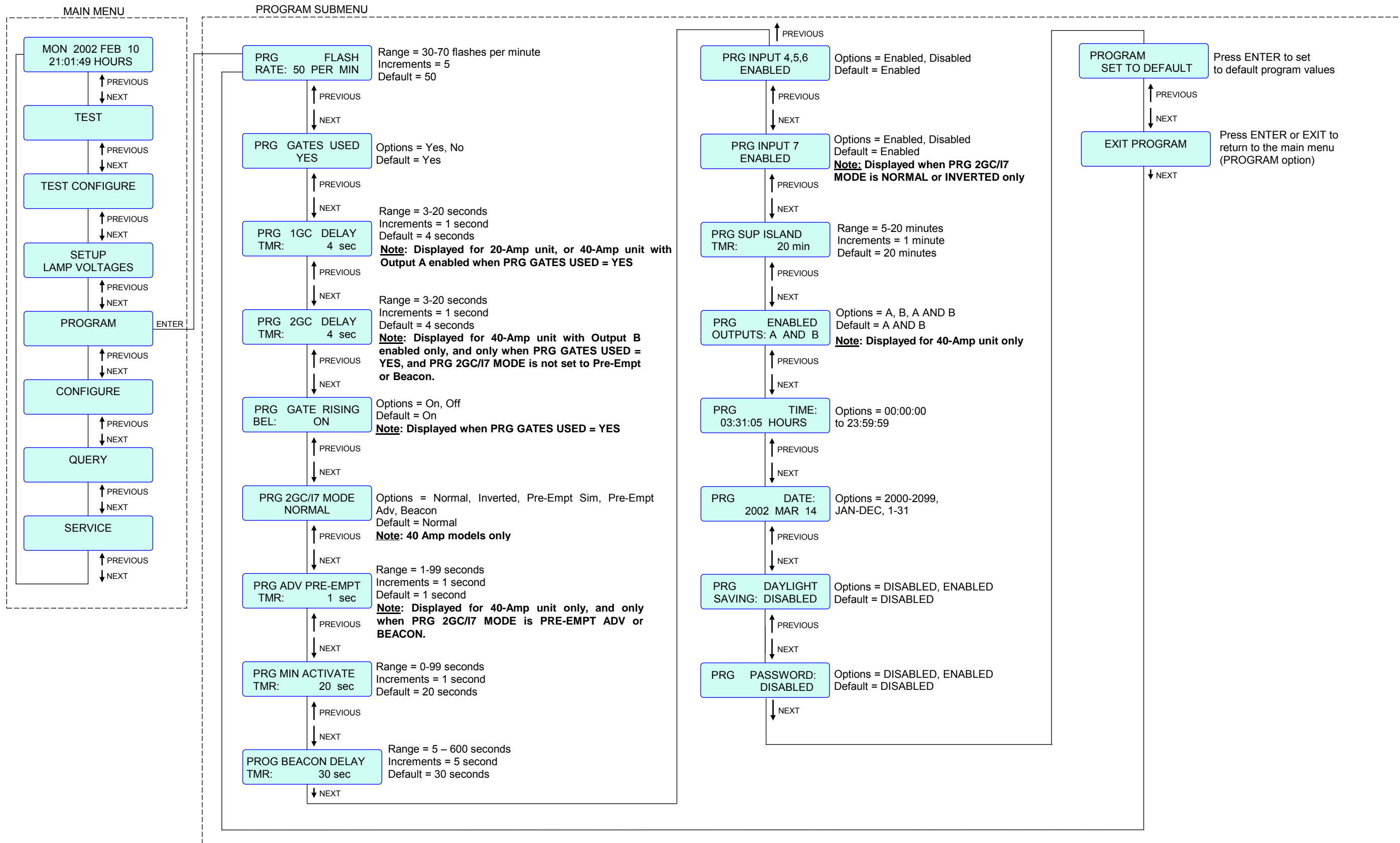

Figure 4-22. SUPISL MCF Program Menu Flow Diagram

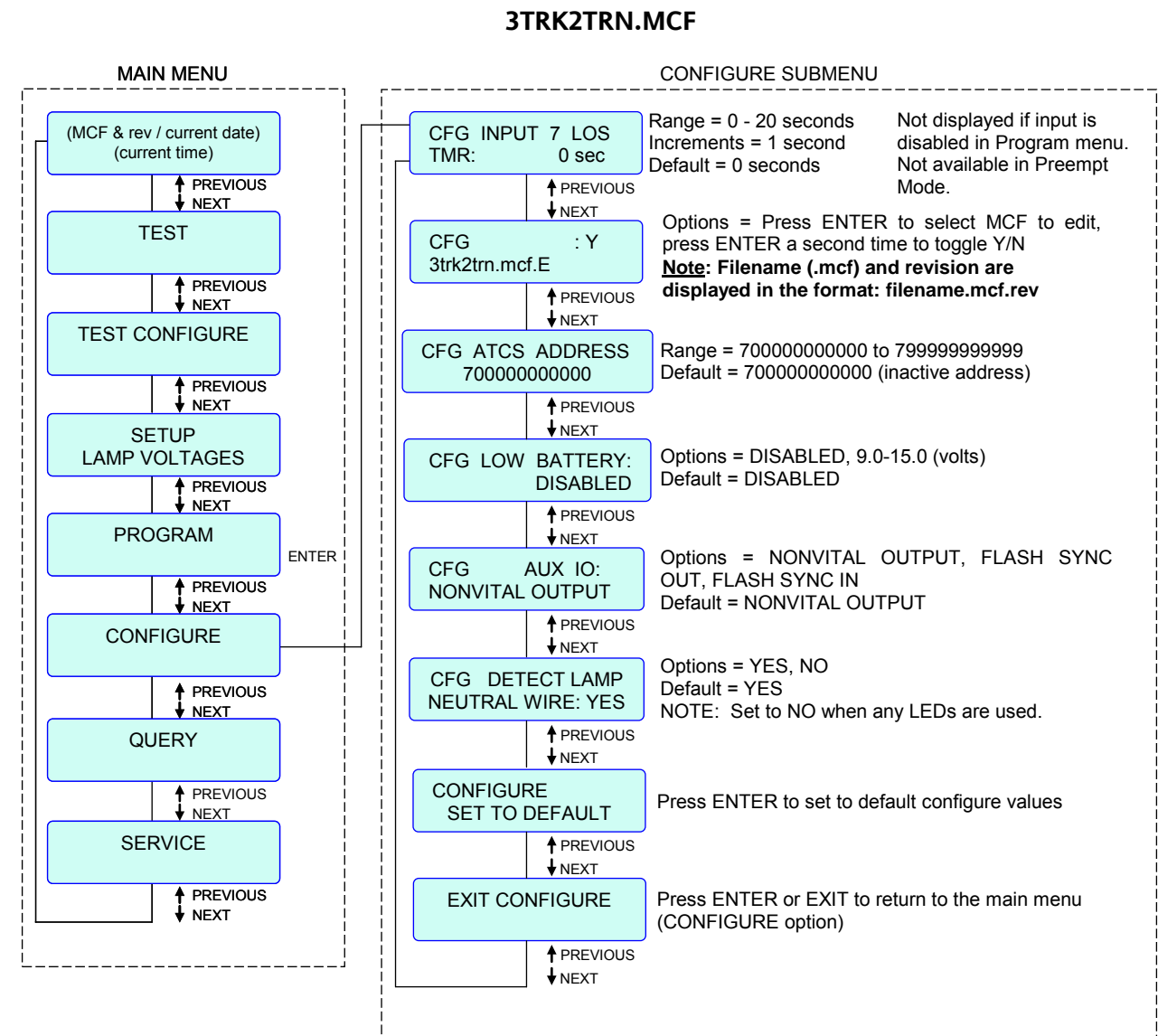

Figure 4-23. 3TRK2TRN MCF Configure Menu Flow Diagram



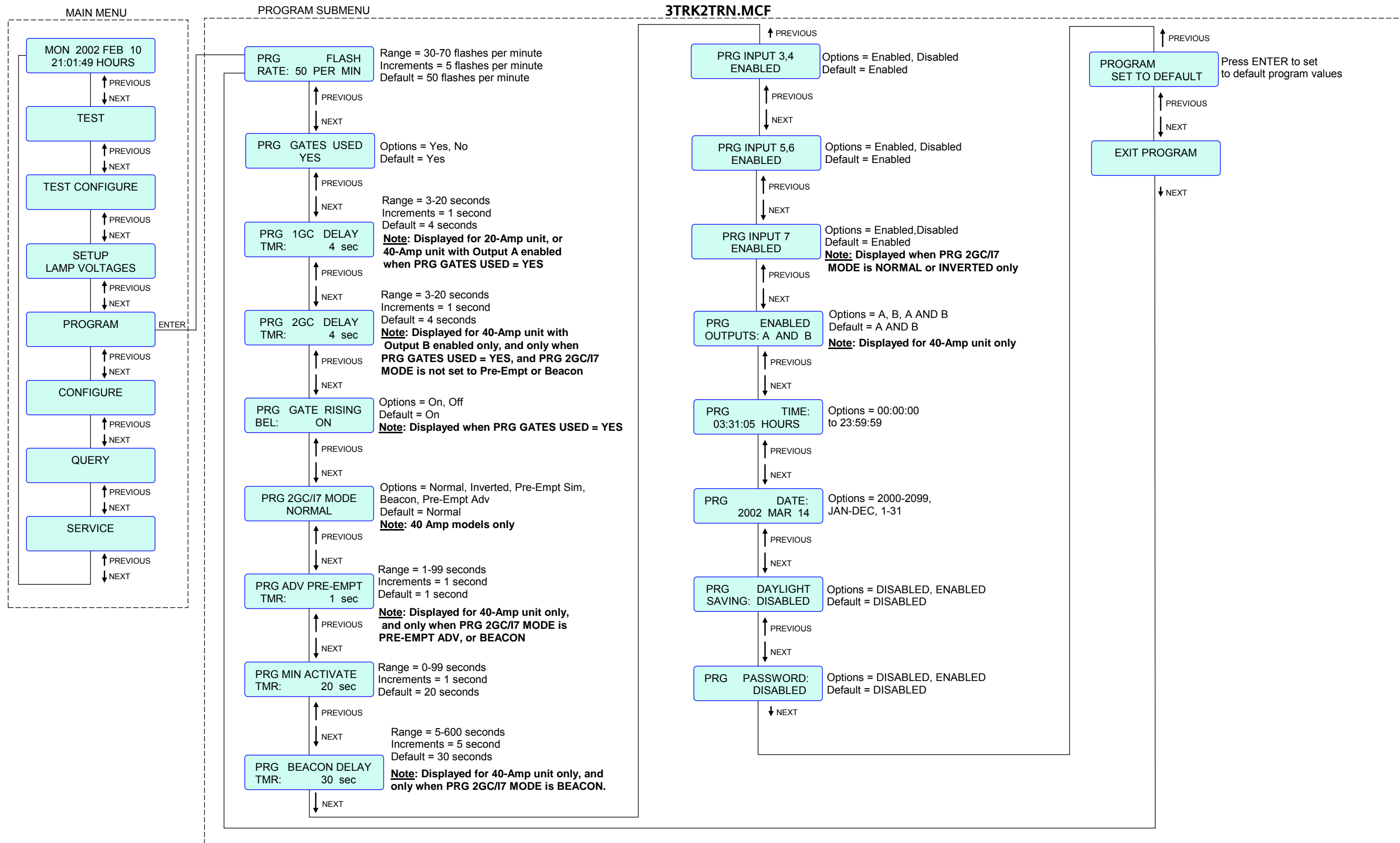

Figure 4-24. 3TRK2TRN MCF Program Menu Flow Diagram

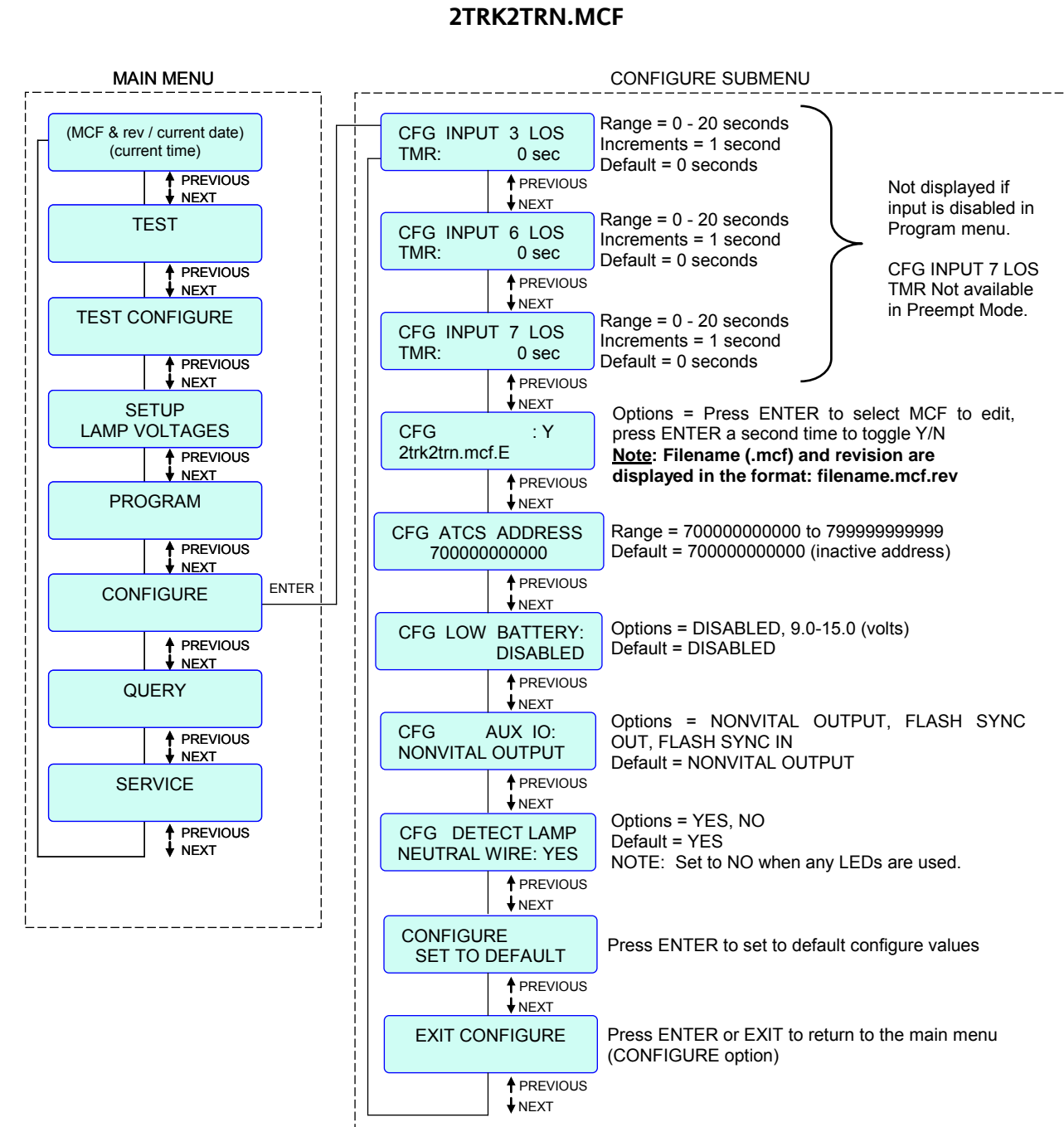

Figure 4-25. 2TRK2TRN MCF Configure Menu Flow Diagram

2TRK2TRN.MCF

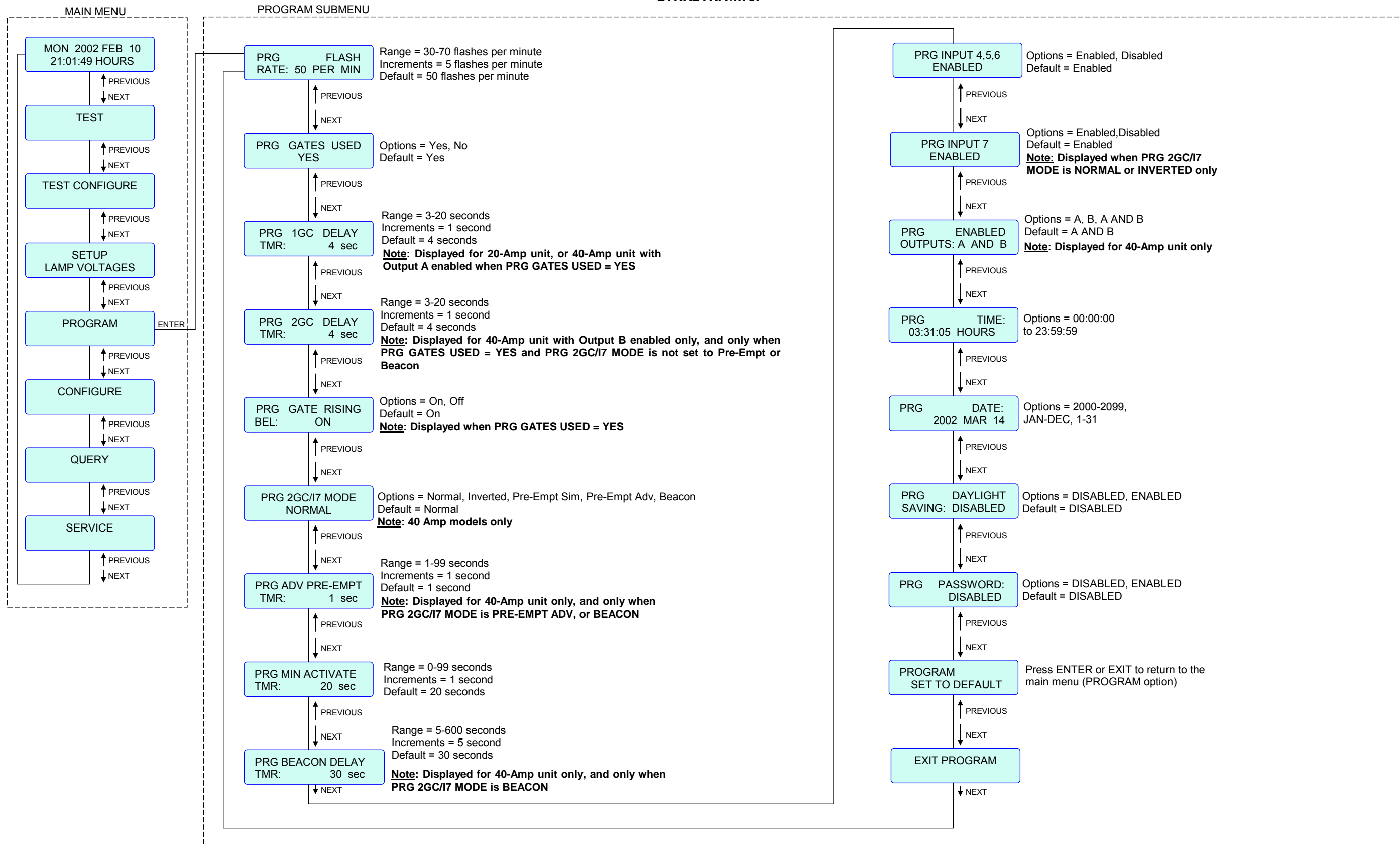

Figure 4-26. 2TRK2TRN MCF Program Menu Flow Diagram

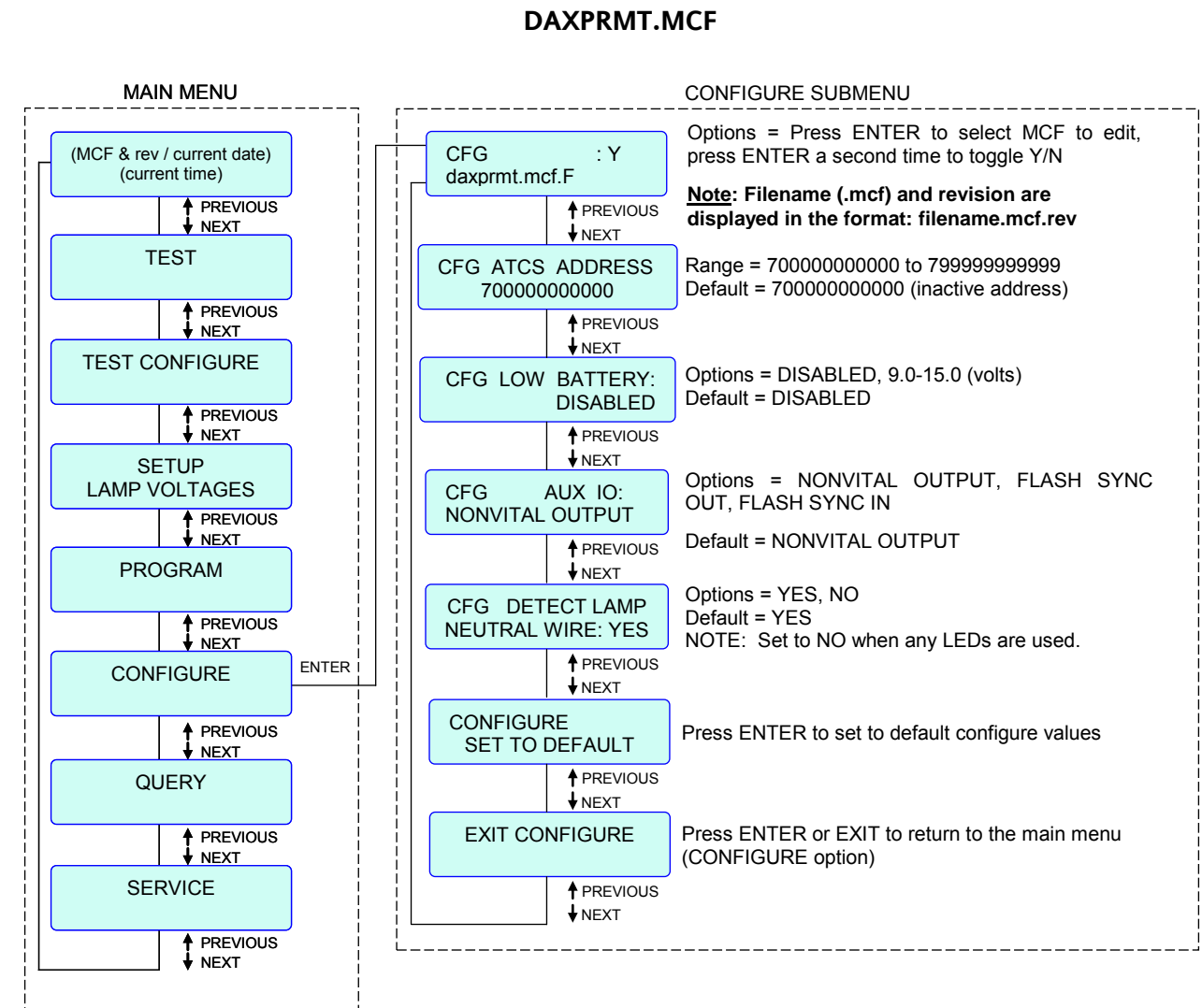

Figure 4-27. DAXPRMT MCF Configure Menu Flow Diagram

DAXPRMT.MCF

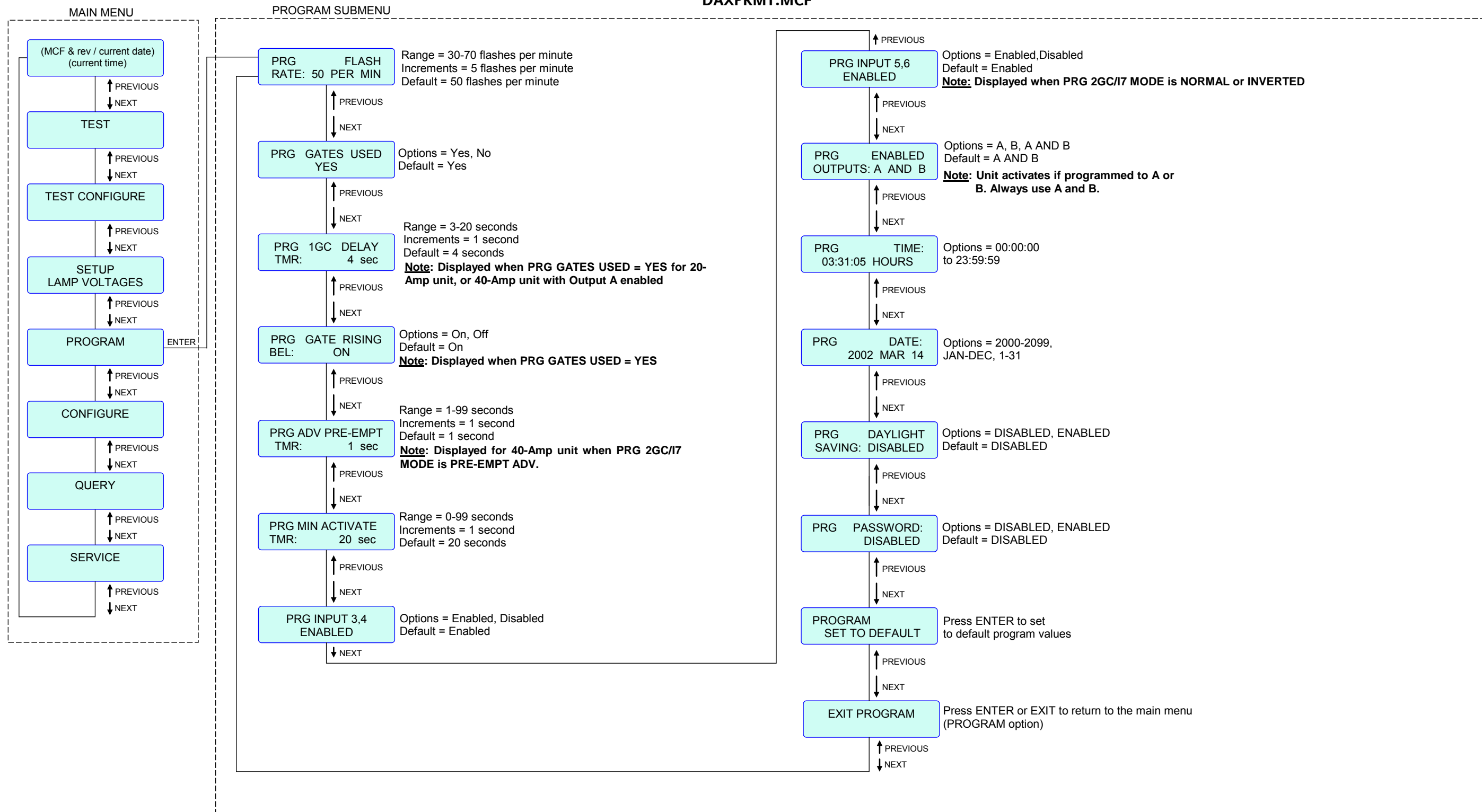

Figure 4-28. DAXPRMT MCF Program Menu Flow Diagram

This page intentionally left blank |

## SECTION 5 APPLICATION PROGRAMMING

### 5.1 GENERAL

Following installation and prior to placing it in operation, the SSCC III PLUS unit must be properly programmed for the specific site. This section provides step by step application programming instructions. When power is applied to the SSCC III PLUS and bootup has completed, the display comes up in the Main Menu (refer to figure 5-1). Each submenu has an EXIT function to return to the main menu, or after 90 seconds of inactivity the display automatically returns to the idle screen in the main menu.

**WARNING**

**⚠ WARNING**

**FOLLOWING INSTALLATION / MAINTENANCE, THE SYSTEM VERIFICATION TESTS IN SECTION VI MUST BE PERFORMED.**

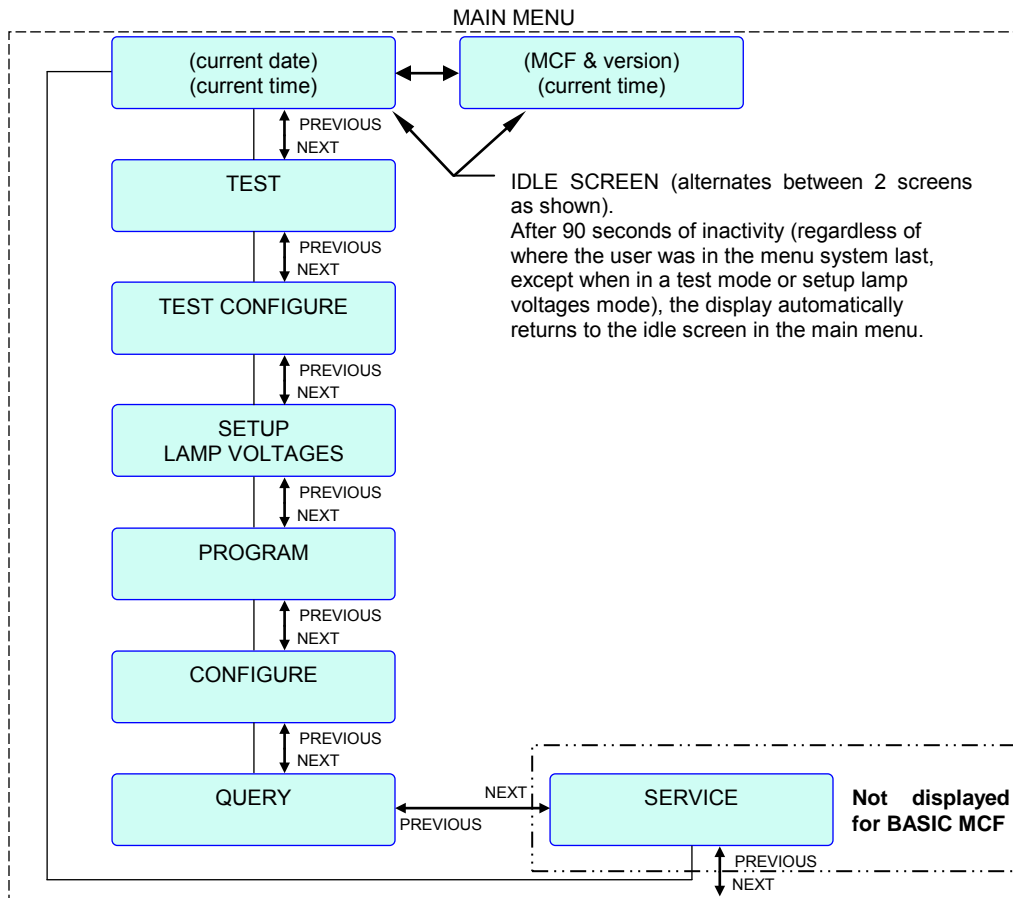

**Figure 5-1. SSCC III PLUS Main Menu**

## 5.2 PROGRAMMING THE SSCC III PLUS

Default settings can be changed in the field by following the built-in menu system (refer to Section IV for general information on the menu system). All programming entries should be recorded on the History Card supplied with the unit (a master copy is located at the end of this manual).

### **WARNING**

**WARNING**

**ALL PROGRAM AND CONFIGURE PARAMETERS MUST BE SET TO APPROVED RAILROAD DESIGN AND APPLICABLE GOVERNMENT REGULATIONS.**

### **NOTE**

**NOTE**

At initial cut-over, the crossing will generally be constantly activated until the SSCC III PLUS is programmed and the required inputs are present.

SSCC III PLUS programming is accomplished by using the two front panel rocker switches (S1 and S2) and the liquid crystal display. The NEXT / PREVIOUS switch (S1) is used to scroll through menus and change values for selected menu items.

The ENTER function of the ENTER / EXIT switch (S2) is used to select menus and displayed menu items, to enter the editing mode for application values and save the new application values. The EXIT function of S2 is used to abandon an edit function for a selected menu item and to exit to the next higher level.

Several menu items provide two possible settings (e.g., ENABLED or DISABLED). When the edit mode is selected for one of these “toggle” items by pressing <ENTER>, the setting can be toggled to the opposite setting by using either the NEXT or PREVIOUS function.

### **NOTE**

**NOTE**

If the values in a menu item are not to be changed, press <NEXT> when the menu item is displayed to proceed to the next menu item.

### 5.2.1 Order of Steps to Program the SSCC III PLUS

All initial SSCC III PLUS application programming should be performed in the following order:

1. Using the CONFIGURE menu (paragraph 5.2.1.1), verify/select the desired MCF.
2. Using the PROGRAM menu (paragraph 5.2.1.2), program all necessary menu steps per railroad design.



3. Using the CONFIGURE menu (paragraph 5.2.1.3), program all necessary menu steps for the MCF selected per railroad design (do not re-enter the selected MCF from step 1 above).
4. Using the TEST CONFIGURE menu (paragraph 5.2.1.4), program all desired menu steps.

**NOTE**

**NOTE**

When completed, the system will be ready for lamp voltage calibration and verification of crossing operation.

**WARNING**

**WARNING**

**EVERY SSCC III PLUS HAS A SET OF FACTORY INSTALLED MCF FILES. THE PROPER MCF MUST BE SELECTED AT THE TIME OF INSTALLATION ACCORDING TO THE APPLICATION DESIGN PRIOR TO PROGRAMMING ANY SUB-MENUS IN THE PROGRAM MENU.**

**NOTE**

**NOTE**

When Out Of Service mode is enabled, some programming options are disabled and not displayed.

### 5.2.1.1 Verify/Select the Desired MCF

1. To verify that the desired MCF is presently selected, press EXIT twice and scroll until the Time and Date is displayed. The presently selected MCF name will alternately be displayed (see example below).

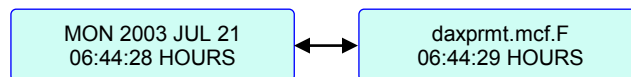

2. **If the desired MCF is displayed, skip to paragraph 5.2.1.2, *Using the Program Menu.***
3. If a new MCF is to be selected, scroll through the main menu until **CONFIGURE** (CFG) is displayed, then press <ENTER>.
4. Scroll through the CFG menu until the presently installed MCF name appears on the display similar to the example below (see table 5-1 for a list of MCF names), then press <ENTER>.

```

CFG          : Y
daxprmt.mcf.F
  
```

5. Scroll through the MCF options until the desired MCF is displayed (see example below).

```
CFG          : N
basicols.mcf.H
```

6. When the desired MCF is displayed, press <ENTER>. A message is displayed similar to the following:

```
CFG          : N
CRC IS 731AF326
```

7. Press <NEXT> until a “Y” appears in the display similar to the following:

```
CFG          : Y
CRC IS 731AF326
```

8. When the “Y” is displayed, press <ENTER>. The following message is displayed:

```
ENTER MCF
ID NUMBER: 413
```

9. The correct 3-digit ID number must be entered in place of the currently displayed one (see table 5-1 for ID numbers) as follows:
- Press <NEXT> or <PREVIOUS> until the correct first digit of the ID is displayed, then press <ENTER>.
  - Press <NEXT> or <PREVIOUS> until the correct second digit of the ID is displayed, then press <ENTER>.

**WARNING****WARNING**

**IF THE SSCC IS PRESENTLY IN CONTROL OF THE LIGHTS AND GATES, CONTINUING WITH THE NEXT STEP (c) WILL CAUSE THE GATES TO COME DOWN AND THE LIGHTS TO FLASH UNTIL THE NEW MCF APPLICATION IS PROGRAMMED.**

- Press <NEXT> or <PREVIOUS> until the correct third digit of the ID is displayed, then press <ENTER>.

**NOTE****NOTE**

If the correct ID was entered, the SSCC processors go through an install/bootup process for about 20 seconds, after which the Time and Date screen appears and alternately displays the selected MCF name

**Table 5-1. Available MCFs**

<b>MCF</b>	<b>ID</b>	<b>Description</b>
BASIC	130	Basic crossing activation application, where all detection inputs are logically ANDed together with optional LOS timers (same as SSCC IIIA).
BASICPLS	087	Same as basic application plus additional functions that are available on all MCFs except BASIC, such as “Out Of Service” mode, traffic signal pre-emption output, optional second gate-control (normal, inverted for Exit gate control, or simultaneous or advance pre-emption where 2GC output drives a traffic pre-empt relay). In addition, this MCF supports active beacons on highway-railroad advance warning signs.
3TRK1WRP	682	Triple track, GCPs with single Wrap Circuit per track. Each Wrap Circuit and configurable input 7 have an optional LOS timer. Can be programmed for optional second gate-control output (see BASICPLS MCF). In addition, this MCF supports active beacons on highway-railroad advance warning signs.
2TRK2WRP	606	Double track, GCPs with double Wrap Circuit per track. Each Wrap Circuit and configurable input 7 have an optional LOS timer. Can be programmed for optional second gate-control output (see BASICPLS MCF). In addition, this MCF supports active beacons on highway-railroad advance warning signs.
2TRKDSTK	320	Directional Stick Logic, Double Track, (PSO, IPI, Style C), with Vital Stick Cancellation Timer. Optional LOS timers on each input. Can be programmed for optional second gate-control output (see BASICPLS MCF). In addition, this MCF supports active beacons on highway-railroad advance warning signs and an optional test switch input for activating warning devices and releasing the directional stick.
SUPISL	285	Double Track, Supplemental Island – Double Track GCP and conventional island with a Supplemental Island (such as a wheel counter system). Supplemental Island logic requires both conventional and supplemental islands to be energized before island logic energizes. LOS timers on supplemental island input and configurable input 7. Can be programmed for optional second gate-control output (see BASICPLS MCF). ). In addition, this MCF supports active beacons on highway-railroad advance warning signs.
3TRK2TRN	962	Second Train Coming logic on Triple Track with GCP. Input 7 has optional LOS timer. Can be programmed for optional second gate-control output (see BASICPLS MCF). In addition, this MCF supports active beacons on highway-railroad advance warning signs.
2TRK2TRN	065	Second Train Coming logic with Wrap Circuit on Double Track with GCP. Each Wrap Circuit and the configurable input 7 have an optional LOS timer. Can be programmed for optional second gate-control output (see BASICPLS MCF). In addition, this MCF supports active beacons on highway-railroad advance warning signs.
DAXPRMT	413	Traffic Signal Advance Pre-emption Control – Double Track GCP and DAX (Advance Pre-emption) outputs feed directly into SSCC IV, and the second “Gate Control” output controls the Traffic Signal Pre-emption Relay. Not available on 20-Amp units.

This completes the MCF selection.

### 5.2.1.2 Using the PROGRAM Menu

1. Scroll through the main menu until **PROGRAM** is displayed, then press <ENTER>. A message is displayed similar to the following:

```
PRG      FLASH
RATE: 50 PER MIN
```

#### NOTE

**NOTE**

Edit mode (where the system allows changes to be made) is indicated by a flashing cursor. If a parameter is not to be changed, press <NEXT> to advance to the next parameter.

2. Press <ENTER> to edit (change flash rate), scroll until the desired value is displayed, then press <ENTER> again to save the new selection.
3. Press <NEXT>. For all MCFs except BASIC, a message is displayed similar to the following:

```
PRG GATES USED
      YES
```

#### NOTE

**NOTE**

If “PRG GATES USED” is “NO”, skip to step 11.

4. If the above screen is displayed, press <ENTER> to edit (select “gates used” option), scroll until the desired option is displayed, then press <ENTER> again to save the new selection.

#### ⚠ WARNING

**WARNING**

**GATE DELAY TIMERS MUST BE CONFIGURED TO THE CORRECT VALUES.**

#### NOTE

**NOTE**

If a gate control is not used, its corresponding gate delay time must be set to a value that is equal to or less than the used gate delay time. For example, if GC2 is not used, then it must be set to a value equal to or less than GC1.

5. Press <NEXT>. For 20-Amp units, or 40-Amp units with Output A enabled, a message is displayed similar to the following:

```
PRG 1GC DELAY
TMR:      4 sec
```

6. Press <ENTER> to edit (change 1GC delay time), scroll until the desired value is displayed, then press <ENTER> again to save the new selection.
7. Press <NEXT>. For 40-Amp units only with Output B enabled, a message is displayed similar to the following:

```
PRG 2GC DELAY
TMR:      4 sec
```

8. If the above screen is displayed, press <ENTER> to edit (change 2GC delay time), scroll until the desired value is displayed, then press <ENTER> again to save the new selection.
9. Press <NEXT>. A message is displayed similar to the following:

```
PRG GATE RISING
BEL:      ON
```

10. Press <ENTER> to edit (select gate rising bell on/off), toggle until the desired option is displayed, then press <ENTER> again to save the new selection.

**WARNING**

**WARNING**

**AN INPUT CANNOT BE USED TO ACTIVATE A CROSSING IF IT IS NOT ENABLED.**

11. Press <NEXT>. For BASIC MCF only, a message is displayed similar to the following:

```
PRG ENBLD INPUTS
      1 THRU 7
```

12. If the above screen is displayed, press <ENTER> to edit (change enabled inputs), scroll until the desired option is displayed, then press <ENTER> again to save the new selection.

**NOTE**

**NOTE**

For BASIC MCF, skip to step 17. For all other MCFs, go to step 13.

**WARNING**

**WARNING**

**WHEN EXIT GATES ARE USED, SET EXIT GATE DELAY TIMERS IN ACCORDANCE WITH CIRCUIT PLANS. DELAY TIMES ARE DETERMINED BY ENGINEERING STUDY AND ARE GENERALLY LONGER THAN ENTRANCE GATE TIMERS TO ENSURE THAT VEHICLES HAVE TIME TO PASS THE EXIT GATES.**

13. Press <NEXT>. For all MCFs except DAXPRMT, a message is displayed similar to the following:

```
PRG 2GC/I7 mode
NORMAL
```

14. If the above screen is displayed, press <ENTER> to edit (change 2GC/I7 option), scroll until the desired option is displayed, then press <ENTER> again to save the new selection.

**NOTE**

**NOTE**

For the 2TRKDSTK MCF, selecting SIM or ADV will change the 2GC/I7 option to preemption health (PRMPT HEALTH).

15. Press <NEXT>. For 40-Amp units only, if the 2GC/I7 mode (step 14) is set to PRE-EMPT ADV or BEACON, a message is displayed similar to the following:

```
PRG ADV PRE-EMPT
TMR: 1 sec
```

16. If the above screen is displayed, press <ENTER> to edit (change advance pre-emption time), scroll until the desired value is displayed, then press <ENTER> again to save the new selection.

17. Press <NEXT>. A message is displayed similar to the following:

```
PRG MIN ACTIVATE
TMR: 20 sec
```

18. If the above screen is displayed, press <ENTER> to edit (change minimum activation time), scroll until the desired value is displayed, then press <ENTER> again to save the new selection.

**WARNING**

**AN INPUT CANNOT BE USED TO ACTIVATE A CROSSING IF IT IS NOT ENABLED.**

**NOTE**

**NOTE**

For BASIC MCF, skip to step 35. For all other MCFs, go to step 19.

19. If BEACON was selected for PRG 2GC/I7 mode (step 14), then the following message is displayed:

```
PROG BEACON RELAY
TMR: 30 sec
```

20. If the above screen is displayed, press <ENTER> to edit (change beacon relay time), scroll until the desired value is displayed, then press <ENTER> again to save the new selection.

21. If BEACON was selected for PRG 2GC/I7 mode (step 14) and the MCF is 2TRKSTK, then the following menu will appear:

PRO ISL DELAY  
ENABLED

22. If the above screen displays, press <ENTER> to edit (disable island delay), scroll to display DISABLE, and then press <ENTER> again to save this selection.

23. Press <NEXT>. The first configurable input for the selected MCF is displayed (see example below).

PRG INPUT 2  
ENABLED

24. If the displayed configurable input is not to be changed, scroll until the desired configurable input is displayed.

25. Press <ENTER> to edit (enable/disable input), scroll until the desired option is displayed (see example below), then press <ENTER> again to save the new selection.

PRG INPUT 2  
DISABLED

26. Repeat steps 23 and 24 for all configurable inputs to be enabled/disabled.

27. When the MCF is 2TRKDSTK and PRG 2GC/I7 mode is set as Beacon or Pre-Empt, then the PRG INPUT 7 menus allows additional inputs: PRMT HEALTH (only when PRG 2GC/I7 mode is PRE-EMPT SIM or PRE-EMPT ADV) and TEST SWITCH.

PRG INPUT 7  
PRMT HEALTH

28. To change the setting in the above display press <ENTER> to edit scroll to display the desired selection and then press <ENTER> again to save this selection.

29. If PRG INPUT 7 is set to TEST SWITCH, the following display appears:

PRG TEST SWITCH  
ACTIVATE

30. To change the setting in the above display press <ENTER> to edit scroll to display the desired selection and then press <ENTER> again to save this selection.

31. Press <NEXT>. For 2TRKDSTK MCF only, a message is displayed similar to the following if the Stick Cancellation Timer is not running:

PRG STK RELEASE  
TMR: 15 min

**WARNING**

**THE STICK RELEASE TIMER(S) SHOULD NOT BE SET LONGER THAN THE MINIMUM TIME BETWEEN POSSIBLE TRAIN MOVEMENTS IN OPPOSITE DIRECTIONS ON THE SAME TRACK.**

32. If the above screen is displayed, press <ENTER> to edit (change stick release time), scroll until the desired value is displayed, then press <ENTER> again to save the new selection.
33. Press <NEXT>. For SUPISL MCF only, a message is displayed similar to the following:

```
PRG SUP ISLAND
TMR:      20 min
```

34. If the above screen is displayed, press <ENTER> to edit (change supplemental island time), scroll until the desired value is displayed, then press <ENTER> again to save the new selection.

**WARNING**

**WHEN AN OUTPUT (A OR B) IS NOT ENABLED, IT CANNOT BE USED TO CONTROL THE CROSSING LAMPS, GATES, BELLS, OR TRAFFIC PRE-EMPT APPLICATION.**

35. Press <NEXT>. For 40-Amp units only, a message is displayed similar to the following:

```
PRG   ENABLED
OUTPUTS:  A AND B
```

36. If the above screen is displayed, press <ENTER> to edit (change enabled outputs), scroll until the desired value is displayed, then press <ENTER> again to save the new selection.
37. Press <NEXT>. A message is displayed similar to the following:

```
PRG   TIME:
08:42:58 HOURS
```

38. Press <ENTER> to edit (change time):
- Edit the hours field by scrolling until the desired hour is displayed, then press <ENTER> to move to the minutes field.
  - Edit the minutes field by scrolling until the desired minute is displayed, then press <ENTER> to move to the seconds field.
  - Edit the seconds field by scrolling until the desired seconds is displayed, then press <ENTER> to save and complete the time setup.



**NOTE**

**NOTE**

While in edit time mode, pressing <EXIT> from any display discards changes and returns to the **PRG TIME** display.

39. Press <NEXT>. A message is displayed similar to the following:

PRG	DATE:
2007	FEB 8

40. Press <ENTER> to edit (change date):

- a. Edit the year field by scrolling until the desired year is displayed, then press < ENTER > to move to the month field.
- b. Edit the month field by scrolling until the desired month is displayed, then press < ENTER > to move to the day field.
- c. Edit the day field by scrolling until the desired day is displayed, then press < ENTER > to save and complete the date setup.

**NOTE**

**NOTE**

While in edit date mode, pressing <EXIT> from any display discards changes and returns to the **PRG DATE** display.

41. Press <NEXT>. A message is displayed similar to the following:

PRG	DAYLIGHT
SAVING:	DISABLED

42. Press <ENTER> to edit (enable/disable daylight saving), toggle until the desired setting is displayed, then press <ENTER> again to save the setting.

**NOTE**

**NOTE**

It is recommended that arming the password be postponed until all programming and configuration have been performed, and lamp voltages have been set up (refer to Section 6 for setting up lamp voltages).

43. Press <NEXT>. If the following message is displayed:

```
PRG    PASSWORD:
        DISABLED
```

then press <ENTER> until the following message is displayed (option toggles):

```
PRG    PASSWORD:
        ENABLED
```

44. Press <ENTER> to edit (password):

#### NOTE

When in password edit mode and a previous password has been assigned and enabled, the current password is prompted for as shown at right.

```
ENTER
PASSWORD: 0000
```

#### NOTE

If a password has not been enabled (even if assigned), the display prompts to edit or assign a new password as follows:

```
PROGRAM    NEW
PASSWORD:  0000
```

- Edit the first digit field by scrolling until the desired number is displayed, then press <Enter> to move to the second digit field.
- Edit the second digit field by scrolling until the desired number is displayed, then press <Enter> to move to the third digit field.
- Edit the third digit field by scrolling until the desired number is displayed, then press <Enter> to move to the fourth digit field.
- Edit the fourth digit field by scrolling until the desired number is displayed, then press <Enter> to save (if a *new* password) and complete the password setup.

#### NOTE

If a password has been entered and saved, but it is not desired to arm it, toggle the password status to display **DISABLED** and press <ENTER>. A “saving changes” message is temporarily displayed, followed by **PRG PASSWORD DISABLED**. The next time the password is set to **ENABLED** and <ENTER> is pressed, the current password appears to allow the user to change the password or to enable (arm) it.

#### NOTE

45. Set the PRG PASSWORD ENABLED/DISABLED to the desired option and press <ENTER>.

46. Press <EXIT> to exit program mode and return to the main menu.

### 5.2.1.3 Using the CONFIGURE Menu

**NOTE**

**NOTE**  
When Out Of Service mode is enabled, some Configure options are disabled and not displayed.

**NOTE**

**NOTE**  
To exit the Configure menu at any time, press <EXIT> or scroll to the Configure option “Exit Configure” and press <ENTER>.

**NOTE**

**NOTE**  
When the user is asked to “scroll” or “toggle” in the following procedures, the **NEXT** or **PREVIOUS** push buttons are to be pressed, as appropriate.

1. Scroll the main menu until **CONFIGURE** is displayed, then press <ENTER>. The first *configured* LOS is displayed (see example below).

```
CFG INPUT 1 LOS
0 sec
```

2. If the displayed LOS is not to be changed, scroll until the desired configured LOS is displayed.

**NOTE**

**NOTE**  
Edit mode (where the system allows changes to be made) is indicated by a flashing cursor. If a parameter is not to be changed, press <NEXT> to advance to the next parameter.

3. Press <ENTER> to edit (change LOS delay time), scroll until the desired value is displayed (see example below), then press <ENTER> to save the new selection.

```
CFG INPUT 1 LOS
2 sec
```

4. Repeat steps 2 and 3 for all configured LOS delay times to be changed.
5. Press <NEXT>. A message is displayed similar to the following (the **Y/N** field displays **Y** to indicate the currently selected MCF is being displayed):

```
CFG          : Y
basicpls.mcf.H
```

**NOTE**

**NOTE**

If the displayed MCF is the correct one, press <NEXT> to proceed to configuring the ATCS address (step 10). Skip steps 6 through 9.

- To change the MCF, press <ENTER> to enter edit mode (change MCF), scroll until the desired MCF is displayed (see example below), then press <ENTER> again to select the MCF and display its CRC.

```
CFG           : N
3trk2trn.mcf.E
```

**NOTE**

**NOTE**

When the CRC is displayed, verify/correct it, since the MCF will not execute until the CRC is correct (see example below).

```
CFG           : N
CRC IS 054AA764
```

**NOTE**

**NOTE**

Pressing <ENTER> when the Y/N field is displaying “N” causes the MCF to be disabled. To execute the MCF, make certain the “Y” is displayed before pressing <ENTER> in the following step.

- Press <NEXT> to change the Y/N field to display “Y”, then press <ENTER>. The following prompt is displayed:

```
ENTER MCF
ID NUMBER: 000
```

**NOTE**

**NOTE**

The correct MCF ID number is provided in table 3-1 and table 5-1, or supplied by railroad supervisory personnel.

**WARNING**

**WARNING**

**PRESSING <ENTER> IN THE NEXT STEP CAUSES THE SYSTEM TO REBOOT. WHILE REBOOTING, WHICH TAKES ABOUT ONE HALF MINUTE, THE CROSSING GATES ARE DOWN WITH LAMPS FLASHING AND BELLS RINGING (REGARDLESS OF THE STATE OF THE VITAL CROSSING CONTROL INPUTS).**

**PROVIDE FOR AN ALTERNATIVE MEANS OF ACTIVELY WARNING HIGHWAY USERS OF APPROACHING TRAINS, WHICH COMPLIES WITH REGULATIONS AND RAILROAD PROCEDURES, WHEN THE SSCC III PLUS HAS AN INPUT TAKEN OUT OF SERVICE.**

8. Enter the correct MCF ID number and press <ENTER>. A “saving changes” message is temporarily displayed, followed by the message below as the system begins to reboot:

```
REBOOTING TO LOAD
NEW MCF
```

9. After the system has rebooted (standard bootup messages are displayed), the idle screen (current date alternating with MCF & rev/time) is displayed. Press <ENTER> to enter the main menu, scroll the main menu until **CONFIGURE** is displayed, then press <ENTER> again.

10. Press <NEXT> until a message similar to the following is displayed (may show the default ATCS address or a previous ATCS address selection):

```
CFG ATCS ADDRESS
700000000000
```

11. Press <ENTER> to edit (change ATCS address), scroll each position until the desired value is displayed, then press <ENTER> to move to the next position.

The ATCS address is formatted as follows: **7.RRR.LLL.GGG.SS**

Where:

**7** is the designation for ATCS wayside type addressing,

**RRR** is the Railroad number,

**LLL** is the Line number,

**GGG** is the Group number,

**SS** is the subnode number.

#### NOTE

#### NOTE

To establish communications, the Subnode number must be 03 or greater.

12. When all digits of the ATCS address are displayed correctly and the last digit is underscored and flashing, press <ENTER> again to save the new ATCS address.

13. Press <NEXT>. A message is displayed (may show DISABLED or a voltage) similar to the following:

```
CFG LOW BATTERY:
DISABLED
```

14. Press <ENTER> to edit (select CFG LOW BATTERY option), scroll until the desired option is displayed, then press <ENTER> again to save the new selection.

15. Press <NEXT>. A message is displayed similar to the following:

```
CFG AUX I/O:
NONVITAL OUTPUT
```

16. Press <ENTER> to edit (change the non-vital output selection), scroll until the desired option is displayed, then press <ENTER> again to save the new selection.
17. Press <NEXT>. A message is displayed similar to the following:

```
CFG DETECT LAMP
NEUTRAL WIRE: YES
```

18. Press <ENTER> to edit (change CFG DETECT LAMP NEUTRAL WIRE option), scroll until the desired option is displayed, then press <ENTER> again to save the new selection.
19. Press <EXIT> to exit configure mode and return to the main menu, or press <ENTER> to display the following message, then press <ENTER> or <EXIT> to return to the main menu.

```
EXIT CONFIGURE
```

#### 5.2.1.4 Using the TEST CONFIGURE Menu

1. Scroll the main menu until **TEST CONFIGURE** is displayed, then press <ENTER>. A message is displayed similar to the following:

```
TC LMP TST CANCL
TMR:          5 min
```

#### **NOTE**

#### **NOTE**

Edit mode (where the system allows changes to be made) is indicated by a flashing cursor. If a parameter is not to be changed, press <NEXT> to advance to the next parameter.

2. Press <ENTER> to edit (change lamp test cancel time), scroll until the desired value is displayed, then press <ENTER> again to save the new selection.
3. Press <NEXT>. A message is displayed similar to the following:

```
TC LMP TST DELAY
TMR:          30 sec
```

4. Press <ENTER> to edit (change lamp test delay time), scroll until the desired value is displayed, then press <ENTER> again to save the new selection.
5. Press <NEXT>. A message is displayed similar to the following:

```
TC LMP TST ON
TMR:          15 sec
```

6. Press <ENTER> to edit (change lamp test on time), scroll until the desired value is displayed, then press <ENTER> again to save the new selection.
7. Press <EXIT> to exit test configure mode and return to the main menu.

### 5.2.2 Using the Out of SERVICE Menu (Not available in the BASIC MCF)

The Out of Service feature is used to take the train detection inputs of the controller, or the inputs associated with a track, out of service. To take inputs out of service requires several deliberate steps to minimize errors. When an input is out of service, three events occur:

1. the LED associated with the input flashes at fast rate to draw attention to the out of service status,
2. the MAINT CALL is deenergized,
3. and the out of service event is logged in the internal History Status Log.

#### **WARNING**

**WARNING**

**PROVIDE FOR AN ALTERNATIVE MEANS OF ACTIVELY WARNING HIGHWAY USERS OF APPROACHING TRAINS, WHICH COMPLIES WITH REGULATIONS AND RAILROAD PROCEDURES, WHEN THE SSCC III PLUS HAS AN INPUT TAKEN OUT OF SERVICE.**

#### **WARNING**

**WARNING**

**IF INPUT POWER IS LOST OR THE CROSSING CONTROLLER IS RESET WHILE ACTIVATION INPUTS OR THE CROSSING CONTROLLER ARE OUT OF SERVICE, THE OUT OF SERVICE MODE IS CANCELLED AND THE CROSSING CONTROLLER FUNCTIONS NORMALLY AFTER BOOTUP.**

#### **NOTE**

**NOTE**

When Out of Service mode is selected for 1 to 7 crossing activation inputs, the GP input will still activate the crossing controller, and all test modes are still functional. Also, the crossing will activate if an SSCC internal failure is detected.

4. Scroll the main menu until **SERVICE** is displayed, then press <ENTER>. A message is displayed similar to the following:

OS SERVICE MODE  
IN SERVICE

**NOTE**

**NOTE**  
Once “OUT OF SERVICE” is selected in the next steps, the user has 5 minutes to select OS method, set timed or constant, define inputs, and confirm and save the changes, otherwise the system reverts to the default option (IN SERVICE).

**NOTE**

**NOTE**  
Edit mode (where the system allows changes to be made) is indicated by a flashing cursor. If a parameter is not to be changed, press <NEXT> to advance to the next parameter.

5. Press <ENTER> to enter edit mode, press <NEXT> to toggle to “OUT OF SERV”, then press <ENTER> again. A **Saving Changes...** message is displayed followed by the message below:

OS SERVICE MODE  
OUT OF SERV

6. Press <NEXT>. The message below is displayed:

OS METHOD  
BY INPUT

7. Use the appropriate method below to select the desired OS method:
- If all crossing controller activation inputs are to be taken out of service, press <ENTER> to enter edit mode, toggle the option to “CONTROLLER”, then press <ENTER> again. A **Saving Changes...** message is displayed, followed by the message below:

OS METHOD  
CONTROLLER

Skip steps 5 and 6 and proceed to step 7.



**NOTE****NOTE**

Although “OS METHOD CONTROLLER” disables all 7 activation inputs, the GP input (#8) is still active and will operate the crossing controller if any gates are down (lights will flash and bells will ring).

- b. If individual or groups of crossing activation inputs are to be taken out of service, press <NEXT> (with “OS METHOD BY INPUTS” displayed). The first configured and enabled input is displayed (see example below).

OS INPUT 1  
NO

8. Scroll until the input to be placed out of service is displayed, press <ENTER> to enter edit mode, then toggle the option to **YES**, and press <ENTER> again. A **Saving Changes...** message is displayed, followed by a message similar to the following:

OS INPUT 1  
YES

9. Repeat step 5 for all inputs to be placed out of service.
10. Press <NEXT> until **OS OPTION** is displayed (the default is “TIMED”).

OS OPTION  
TIMED

Use the appropriate method below to select the desired OS option:

- a. If “OS OPTION TIMED” is desired, press <NEXT> (while “OS OPTION TIMED” is displayed) to display the timer adjustment screen. A message similar to the following is displayed:

OS OUT OF SERV  
TMR: 1 hr

- b. If “OS OPTION CONSTANT” is desired, press <ENTER> (while “OS OPTION TIMED” is displayed) to enter edit mode, toggle to select the **CONSTANT** option, then press <ENTER> again. Skip step 8 and proceed to step 9.

OS OPTION  
CONSTANT

11. If the **TIMED** option was selected in the last step, press <ENTER> (with OUT OF SERVICE TMR: displayed) to enter edit mode, scroll until the correct value is displayed for the out of service timer, and press <ENTER> again.

12. Press <NEXT>. The following message is displayed:

OS TAKE OS NOW?  
NO

13. Press <ENTER> to enter edit mode, toggle the option to “YES”, then press <ENTER> again. A **Saving Changes...** message is displayed.

14. The LEDs on the SSCC III PLUS representing the crossing activation inputs that were taken out of service are now flashing to indicate that they are out-of-service, and the **MAINT CALL** LED is off (to indicate that the Maintenance Call output has been deenergized).

15. Press <NEXT>. The following message is displayed:

EXIT SERVICE

16. Press <ENTER> or <EXIT> to return to the SERVICE submenu of the main menu. The following message is displayed:

SERVICE

**NOTE**

**NOTE**  
If the “Timed” option was selected for out-of-service, the inputs placed out-of-service will revert to the default state of “In Service” after the timeout period has elapsed. If the “Constant” option was selected for out-of-service, the “IN SERVICE” mode will have to be selected by the user in order to terminate the “OUT OF SERVICE” mode.

## SECTION 6

### LAMP VOLTAGE ADJUSTMENT & TESTING

#### 6.1 GENERAL

The SSCC III PLUS is shipped from the factory pre-programmed with a default setting (10.0 volts) for all lamp outputs. Field personnel can adjust these levels to match field conditions by using the front panel rocker switches and display, and following the built-in menu system (refer to Section 4 for information on the menu system). This voltage can be adjusted in the field within the range of 9.0 to 15.0 volts, however the true rms “AC + DC” voltage will not be more than battery voltage minus 1.5 volts.

#### **NOTE**

#### **NOTE**

If attempting to set the L1 or L2 output voltage higher than battery voltage minus 1.5 volts, the following message will continuously flash on the display:

LAMP VOLTS LIMITED BY BATTERY.

#### **NOTE**

#### **NOTE**

While in Lamp Voltage adjustment and testing mode, if a train approaches (XR input logic deenergizes), the test is cancelled and the crossing activates normally. When the train departs, the system remains in normal operation.

#### **WARNING**

#### **WARNING**

**IN LAMP VOLTAGE ADJUSTMENT AND TESTING MODE, IF AN ADVANCE PRE-EMPTION CONFIGURATION IS SET, WARNING DEVICES WILL NOT ACTIVATE IMMEDIATELY WHEN A TRAIN APPROACHES UNTIL THE ADVANCE PRE-EMPT TIMER RUNS. THE 2GC OUTPUT WILL DEENERGIZE IMMEDIATELY.**

#### 6.2 LAMP VOLTAGE DRIVE

The SSCC III PLUS provides a highly efficient voltage-regulated lamp drive output. The lamp drive is a pulse-width modulated voltage with an AC component and a DC component. The benefits of this method of regulation are:

- Lamp voltage remains constant during AC power outages of short duration.
- Lamp voltage remains constant over wide temperature ranges when using temperature compensated battery chargers.
- The output is energy efficient and does not dissipate power as do adjustment resistors.

### 6.3 USE OF LED TYPE LAMPS

A number of different manufacturers currently make LED type lamps. These lamps may have different designs. For example, some LED lamps present a purely resistive load while others have a complete power supply within the lamp case to drive the LEDs. Safetran's FLX-4000 LED flashing light signals are designed to operate with the SSCC III Plus.

Other manufacturer's designs can distort the DC waveform generated by the SSCC III PLUS, which drives the LED lamp. This distortion can result in a difference between what a meter reads at the LED lamp and the voltage shown on the SSCC III PLUS display. Therefore, when using LED lamps, continue to use the "True RMS AC + DC" meter setting on volt meters for the most accurate measurement of the LED lamp voltage.

This distorted DC waveform condition may trigger an "Open Lamp Neutral Wire" detection error when using LEDs; therefore, the OPEN LAMP NEUTRAL DETECT should be turned off (set to NO).

### 6.4 METER READING CONVERSION EXAMPLES

Following are two examples of how to measure the lamp voltages using a conventional meter. In both examples:

- Battery bank voltage is 14.7 volts
- Multimeters are set to read DC

**Table 6-1:  
Multimeter Reading Variance from Actual Lamp Voltages**

Battery Voltage	Regulated Lamp Drive Voltage Range	Measurement Below Actual Drive Voltage	
		Using Digital Multimeter (Fluke 87 or Equivalent)	Using Analog Multimeter (TS111)
13.3	9.0 to 12.0	1.3 volts	0.6 volt
	>12.0	0.91 volt	0.42 volt
14.7	9.0 to 12.0	2.2 volts	1.1 volts
	>12.0	1.54 volts	0.77 volts
15.8	9.0 to 12.0	2.6 volts	2.0 volts
	>12.0	1.82 volts	1.4 volts

### 6.4.1 Lamp Voltage Measurement Example 1

When setting crossing lamp voltages to 9.5 volts, the conventional meter reading is determined by subtracting the meter variance given in Table 6-1 from the desired lamp voltage.

When using a **digital multimeter** (e.g. Fluke 87):

- Desired lamp voltage = 9.5
- Meter variance for 14.7 volt battery = -2.2
- Meter reading = **7.3**

When using an **analog multimeter** (e.g. TS111):

- Desired lamp voltage = 9.5
- Meter variance for 14.7 volt battery = -1.1
- Meter reading = **8.4**

### 6.4.2 Lamp Voltage Measurement Example 2

In this example, it is desired to check that lamp voltage is greater than 8.5 volts and the battery voltage is 13.3 volts.

When verifying that the lamp voltages are greater than 8.5 VDC, the conventional meter reading is determined by subtracting the meter variance given in Table 6-1 from the minimum lamp voltage threshold.

When using a **digital multimeter** (e.g. Fluke 87):

- Minimum lamp voltage threshold = 8.5
- Meter variance for 13.3 volt battery = -1.3
- Minimum meter reading = **7.2**

When using an **analog multimeter** (e.g. TS111):

- Minimum lamp voltage threshold = 8.5
- Meter variance for 13.3 volt battery = -0.6
- Minimum meter reading = **7.9**

## 6.5 LAMP VOLTAGE ADJUSTMENT PROCEDURE



**WARNING**

**TO PREVENT AN OVERVOLTAGE CONDITION AT THE LAMPS, USE A VOLTMETER WITH A “TRUE RMS AC + DC” SCALE AND MAKE ALL MEASUREMENTS USING THAT SCALE.**

To accurately read the incandescent crossing lamp voltages, a “true rms AC + DC” multimeter (e.g., Fluke 187 or 189 digital multimeter) must be used. Conventional multimeters may be used, however the voltage read on the meter will vary from “true rms AC + DC”. The variance is not a set percentage and is dependent on battery voltage. A conversion table cross-referencing several conventional meters is provided in Appendix A.

The lamp voltage adjustment procedure can be divided into two parts for each SSCC III PLUS output. The two parts actually adjust the lamp voltage by two different means or procedures.

The following is a brief explanation of the SSCC III PLUS lamp adjustment procedure. Figure 6-1 shows the typical lamp wiring for one output (A or B).

Referring to figure 6-1, the first part of the procedure adjusts the far gate lamps first (because they have the longest cable length and greatest voltage drop). This is done by adjusting the SSCC III PLUS L1 and then L2 output voltages in 0.1 volt steps until the two lamp voltages are set correctly at the lamps per railroad standards.

The second part of the procedure adjusts the near gate lamp voltages using slide resistors. This is accomplished by first turning on steady the L1 output and then adjusting the L1 slide resistor on the lighting surge panel until the lamp voltage is correct per railroad standards. Secondly, the L2 output is turned on steady and the L2 slide resistor on the lighting surge panel is adjusted until the lamp voltage is correct per railroad standards.

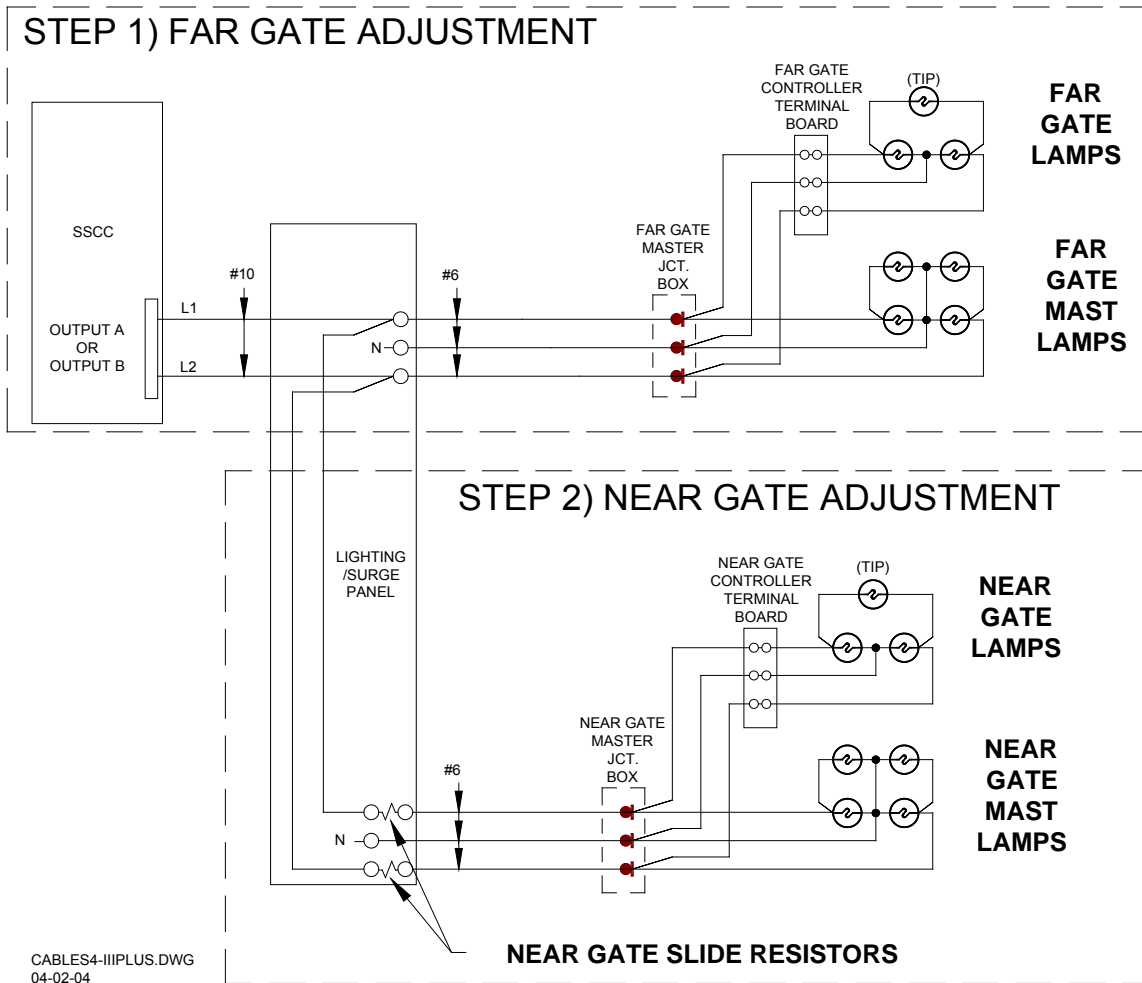

**Figure 6-1. Typical Lamp Wiring**

For a 20-Amp controller, only Output A is adjusted (1 L1 and 1 L2); for a 40-Amp controller, Output B (2 L1 and 2 L2) would be adjusted similarly to Output A.



**WARNING**

**FOLLOWING INSTALLATION, PROGRAMMING AND CONFIGURATION OF THE SSCC III PLUS SYSTEM, AND PRIOR TO PLACING THE SYSTEM IN OPERATION, LAMP VOLTAGES MUST BE ADJUSTED AND SYSTEM OPERATION MUST BE VERIFIED.**

### 6.5.1 Adjustment of FAR Gate Flasher Lamps (Output A)

**NOTE**

**NOTE**

If a “true rms AC + DC” meter is not available, refer to Appendix A for setting lamp voltage.

**NOTE**

**NOTE**

The following procedure adjusts the voltages supplied via the OUTPUT A connector (1 L1 and 1 L2) for the FAR gate (longest cable length). Both the 20-Amp and the 40-Amp units have Output A. If Output A has been disabled in the 40-Amp unit, skip to paragraph 6.5.2.

#### 6.5.1.1 1L1 Adjustment (FAR Gate)

1. Scroll the main menu by pressing <NEXT> until SETUP LAMP VOLTAGES is displayed, then press <ENTER>. The following message is displayed:

SETUP OUTPUT  
1 L1: xx.x VOLTS

2. Press <ENTER> again to enter edit mode (change 1 L1 lamp voltage). Verify that half of the lamps at the FAR gate are lit steady.
3. Connect a “true rms AC + DC” voltmeter across a lighted lamp furthest from the FAR GATE Master Junction Box at the FAR gate location.
4. Using the NEXT and PREVIOUS push buttons, increase or decrease the lamp voltage until the voltage measured at the lamp meets railroad requirements.

**NOTE**

**NOTE**

It is important to be aware that the lamp voltage being measured at the crossing will be different from that displayed at the SSCC III PLUS unit. The lamp voltage on the display of the SSCC III PLUS is the voltage at the output of the unit’s interface connector, and not at the crossing lamp filament. Voltage drops due to cable length will affect the voltage level measured at the lamps.

5. Press <ENTER> to accept changes and exit edit mode.



- The 1 L1 lamps (OUTPUT A) have now been adjusted for the FAR gate. Enter the SSCC III PLUS output voltage settings and the FAR Gate lamp voltage settings for 1 L1 on the History Card for the unit.

### 6.5.1.2 1L2 Adjustment (FAR Gate)

- Press <NEXT> to display SETUP OUTPUT 1 L2 xx.x VOLTS (ensure that it is 1 L2).

SETUP OUTPUT  
1 L2: xx.x VOLTS

- Press <ENTER> to enter edit mode (change 1 L2 lamp voltage). Verify that the other half of the lamps at the FAR gate are lit steady.
- Connect a “true rms AC + DC” voltmeter across a lighted lamp furthest from the FAR GATE Master Junction Box at the FAR gate location.
- Using the NEXT and PREVIOUS push buttons, increase or decrease the lamp voltage until the voltage measured at the lamp meets railroad requirements.
- Press <ENTER> to accept changes and exit edit mode.
- The 1 L2 lamps (OUTPUT A) have now been adjusted for the FAR gate. Enter the SSCC III PLUS output voltage settings and the FAR Gate lamp voltage settings for 1 L2 on the History Card for the unit.

#### NOTE

#### NOTE

If the SSCC III PLUS is a 20-Amp unit, skip to paragraph 6.5.3.

### 6.5.2 Adjustment of FAR Gate Flasher Lamps (Output B, 40-Amp unit only)

#### NOTE

#### NOTE

The following procedure adjusts the voltage supplied via the OUTPUT B connector (2 L1 and 2 L2) of the 40-Amp crossing controller unit only. For 20-Amp units, or if Output B of the 40-Amp unit is disabled, skip to paragraph 6.5.3.

### 6.5.2.1 2L1 Adjustment (FAR Gate)

- Press <NEXT> to display SETUP OUTPUT 2 L1 xx.x VOLTS (ensure that it is 2 L1).

SETUP OUTPUT  
2 L1: xx.x VOLTS

2. Press <ENTER> to enter edit mode (change 2 L1 lamp voltage). Verify that half of the lamps at the other FAR gate are lit steady.

**NOTE**

**NOTE**

If SETUP OUTPUT 2 L1 xx.x VOLTS is not displayed, output B must first be enabled. Refer to Section 5, *Application Programming*, for instructions on how to enable the B outputs.

3. Connect a “true rms AC + DC” voltmeter across a lighted lamp furthest from the FAR GATE Master Junction Box at the FAR gate location.
4. Using the NEXT and PREVIOUS push buttons, increase or decrease the lamp voltage until the voltage measured at the lamp meets railroad requirements.
5. Press <ENTER> to accept changes and exit edit mode.
6. The 2 L1 lamps (OUTPUT B) have now been adjusted for the FAR gate. Enter the SSCC III PLUS output voltage settings and the FAR Gate lamp voltage settings for 2 L1 on the History Card for the unit.

### 6.5.2.2 2L2 Adjustment (FAR Gate)

1. Press <NEXT> to display SETUP OUTPUT 2 L2 xx.x VOLTS (ensure that it is 2 L2).

SETUP OUTPUT  
2 L2: xx.x VOLTS

2. Press <ENTER> to enter edit mode (change 2 L2 lamp voltage). Verify that the other half of the lamps at the FAR gate are lit steady.
3. Connect a “true rms AC + DC” voltmeter across a lighted lamp furthest from the FAR GATE Master Junction Box at the FAR gate location.
4. Using the NEXT and PREVIOUS push buttons, increase or decrease the lamp voltage until the voltage measured at the lamp meets railroad requirements.
5. Press <ENTER> to accept changes and exit edit mode.
6. The 2 L2 lamps have now been adjusted for the FAR gate. Enter the SSCC III PLUS output voltage settings and the FAR Gate lamp voltage settings for 2 L2 on the History Card for the unit.

### 6.5.3 Adjustment of NEAR Gate Flasher Lamps (Output A)

#### NOTE

#### NOTE

The following procedure adjusts the lamp voltages at the NEAR gate (shortest cable length) by adjusting the slide resistors on the lighting surge panel. If Output A for a 40-Amp unit is disabled, skip to paragraph 6.5.4.

1. Press <EXIT> to exit lamp voltage setup mode and return to the main menu.
2. Scroll the main menu using the NEXT or PREVIOUS buttons until TEST is displayed, then press <ENTER>. The following message is displayed:

TST LMPS STEADY  
OFF

3. Press <ENTER> to enter edit mode (select test lamps steady option), scroll until TST LMPS STEADY L1 ON is displayed, then press <ENTER>. Verify that half of the lamps at the NEAR gates are lit steady.

TST LMPS STEADY  
L1 ON

4. Connect a “true rms AC + DC” voltmeter across a lighted lamp furthest from the NEAR GATE Master Junction Box at the NEAR gate location.
5. Adjust the 1 L1 slide resistor on the lighting surge panel until the voltage measured at the lamp meets railroad requirements. Tighten the adjuster on the slide resistor, then verify that the measurement is correct.
6. Press <NEXT> to display TST LMPS STEADY L2 ON. Verify that the other half of the lamps at the NEAR gates are lit steady.

TST LMPS STEADY  
L2 ON

7. Connect a “true rms AC + DC” voltmeter across a lighted lamp furthest from the NEAR GATE Master Junction Box at the NEAR gate location.
8. Adjust the 1 L2 slide resistor on the lighting surge panel until the voltage measured at the lamp meets railroad requirements. Tighten the adjuster on the slide resistor, then verify that the measurement is correct.
9. Press <ENTER> to turn off lamps.
10. The 1 L1 and 1 L2 lamps (OUTPUT A) have now been adjusted for the NEAR gate. Enter the NEAR Gate lamp voltage settings for 1 L1 and 1 L2 on the History Card for the unit.

#### 6.5.4 Adjustment of NEAR Gate Flasher Lamps (Output B, 40-Amp unit only)

##### NOTE

**NOTE**

The following procedure adjusts the Output B lamp voltages (for 40-Amp units only) at the NEAR gate (shortest cable length) by adjusting the slide resistors on the lighting surge panel. For 20-Amp units, or if Output B of a 40-Amp unit is disabled, skip to paragraph 6.6.

1. Press <NEXT> to display TST LMPS STEADY OFF.

TST LMPS STEADY  
OFF

2. Press <ENTER> to enter edit mode (select test lamps steady option), scroll until **TST LMPS STEADY L1 ON** is displayed, then press <ENTER>. Verify that half of the lamps at the NEAR gate are lit steady.
3. Connect a “true rms AC + DC” voltmeter across a lighted lamp furthest from the NEAR GATE Master Junction Box at the NEAR gate location.
4. Adjust the 2L1 slide resistor on the lighting surge panel until the voltage measured at the lamp meets railroad requirements. Tighten the adjuster on the slide resistor, then verify that the measurement is correct.
5. Press <NEXT> to display **TST LMPS STEADY L2 ON**. Verify that the other half of the lamps at the NEAR gate are lit steady.

TST LMPS STEADY  
L2 ON

6. Connect a “true rms AC + DC” voltmeter across a lighted lamp furthest from the NEAR GATE Master Junction Box at the NEAR gate location.
7. Adjust the 2 L2 slide resistor on the lighting surge panel until the voltage measured at the lamp meets railroad requirements. Tighten the adjuster on the slide resistor, then verify that the measurement is correct.
8. Press <EXIT> twice to return to the **TEST** menu option in the main menu.
9. The 2 L1 and 2 L2 lamps (OUTPUT B) have now been adjusted for the NEAR gate. Enter the NEAR Gate lamp voltage settings for 2 L1 and 2 L2 on the History Card for the unit.

## 6.6 FLASHING LIGHT SIGNAL ALIGNMENT

**NOTE****NOTE**

For the following procedure, the gates remain up. To align signal lights while gates are down and lamps are flashing, select ACTIVATE CROSSING instead of TEST LAMPS FLASH.

1. Scroll the main menu until TEST is displayed, then press <ENTER>.
2. Using the NEXT or PREVIOUS buttons, scroll until TEST LAMPS FLASH OFF is displayed, then press <ENTER> to enter edit mode (change the test flash lamps option).

TST FLASH LMPS  
OFF

3. Press <ENTER> again to toggle the option to TST FLASH LMPS ON.
4. Verify the lamps are flashing.
5. Align all flashing light signals in accordance with railroad standards.
6. Press <EXIT> twice to terminate test mode and return to the main menu.
7. Verify that all the lamps have returned to off.

## 6.7 SYSTEM VERIFICATION TESTS

After the system has been programmed, configured, and the lamp voltages have been adjusted, the system must be tested in accordance with paragraph 6.7.1 and railroad/transit company's circuit plans, procedures and instructions.

### 6.7.1 SSCC III PLUS Crossing Operational Check List & Tests

#	Check/Test	√
1	Verify that the light/gate battery is charged.	
2	Verify that all connectors on the SSCC III PLUS have been properly seated and secured.	
3	Verify that all the electrical connections in the Bell, Lamp, and Gate circuits are properly assembled, tightened and secured.	
4	Verify that all flashing lamps light and none are burned out.	
5	Verify that all lights have been aligned.	
6	Verify that the gates are operational.	
7	Verify that the bells are operational.	
8	Verify that all SSCC III PLUS programming is correct (program and configure menus)	
9	Verify that all lamp voltages have been set.	
10	Momentarily turn on the flashers from the TEST menu and verify that the battery charger is operational (providing current to the lamps and battery).	
11	Individually open and close each wire connected to each input to the SSCC III PLUS controlling the gates and lights, and verify that each input controls the crossing warning devices as determined by the programming.	
12	Verify that the gate delay time is correct (time from when flashers start until gates start to descend).	
13	Verify that the lights continue to flash while the gates are rising.	
14	If the "maintenance call" light is being used, verify that it is lit.	
15	If MAINT CALL is used and taking an input out of service is allowed by railroad procedures, take an input out of service to verify MAINT CALL light turns off. Restore input to service and verify MAINT CALL energizes.	
16	Verify that the SSCC III PLUS History Card has been updated.	
17	Verify proper crossing operation by watching train moves on all tracks, or simulate train moves with a track shunt on all crossing control track circuits.	

#### NOTE

#### NOTE

While in Test Mode, if a train approaches (XR input logic deenergizes), the test is cancelled and the crossing activates normally. When the train departs, the system remains in normal operation.



**WARNING**

IN THE TEST MENU “TEST ACTIVATE CROSSING” MODE, IF AN ADVANCE PRE-EMPTION CONFIGURATION IS SET, WARNING DEVICES WILL NOT ACTIVATE IMMEDIATELY WHEN A TRAIN APPROACHES UNTIL THE ADVANCE PRE-EMPT TIMER RUNS. THE 2GC OUTPUT WILL DEENERGIZE IMMEDIATELY.

This page intentionally left blank



## SECTION 7 - TROUBLESHOOTING

### 7.1 GENERAL

The SSCC III PLUS is a single-board system and has no plug-in modules. All inputs, outputs, and power for the unit are completely plug-connected. Therefore, troubleshooting is made very simple.

If the SSCC III PLUS fails, simply remove the mating connectors, change out the unit, verify the correct MCF is selected, reprogram parameters per the History Card and/or circuit plans, and check system calibration of the new unit. Return the unserviceable unit to Siemens Rail Automation Corporation under the Return Material Authorization process, if applicable.



**WARNING**

**IF B OR N ARE FULLY OR PARTIALLY REMOVED, SIGNALS AND/OR GATES MAY NOT OPERATE AS INTENDED. TAKE ALTERNATE MEANS TO WARN VEHICULAR TRAFFIC AND EMPLOYEES.**



**WARNING**

**REMOVING INPUT POWER FROM THE SSCC III PLUS WILL CAUSE THE GATE(S) TO DROP BUT THE LIGHTS WILL NOT ACTIVATE.**

**NOTE**

**NOTE**

When an SSCC failure lowers the gates, 2GC will always de-energize regardless of the 2GC/I7 mode.

### 7.2 TROUBLESHOOTING SSCC III PLUS ERRORS

Generally, problems with the SSCC III PLUS may be categorized as wiring related errors or SSCC III PLUS related errors. Wiring related errors may occur when:

- The gates are down and lights are flashing
- The gates are up and lights are flashing
- Some lights are not operating when others are flashing

SSCC related errors may occur when:

- The SSCC III PLUS reports various error codes in the text window
- Lamp neutral wire open message appears in the text window
- The Maintenance Call (Maint Call or MC) light does not function properly

The troubleshooting flow diagram of figure 7-1 is provided to help determine whether a problem is wiring-related, or SSCC III PLUS-related.

This page intentionally left blank

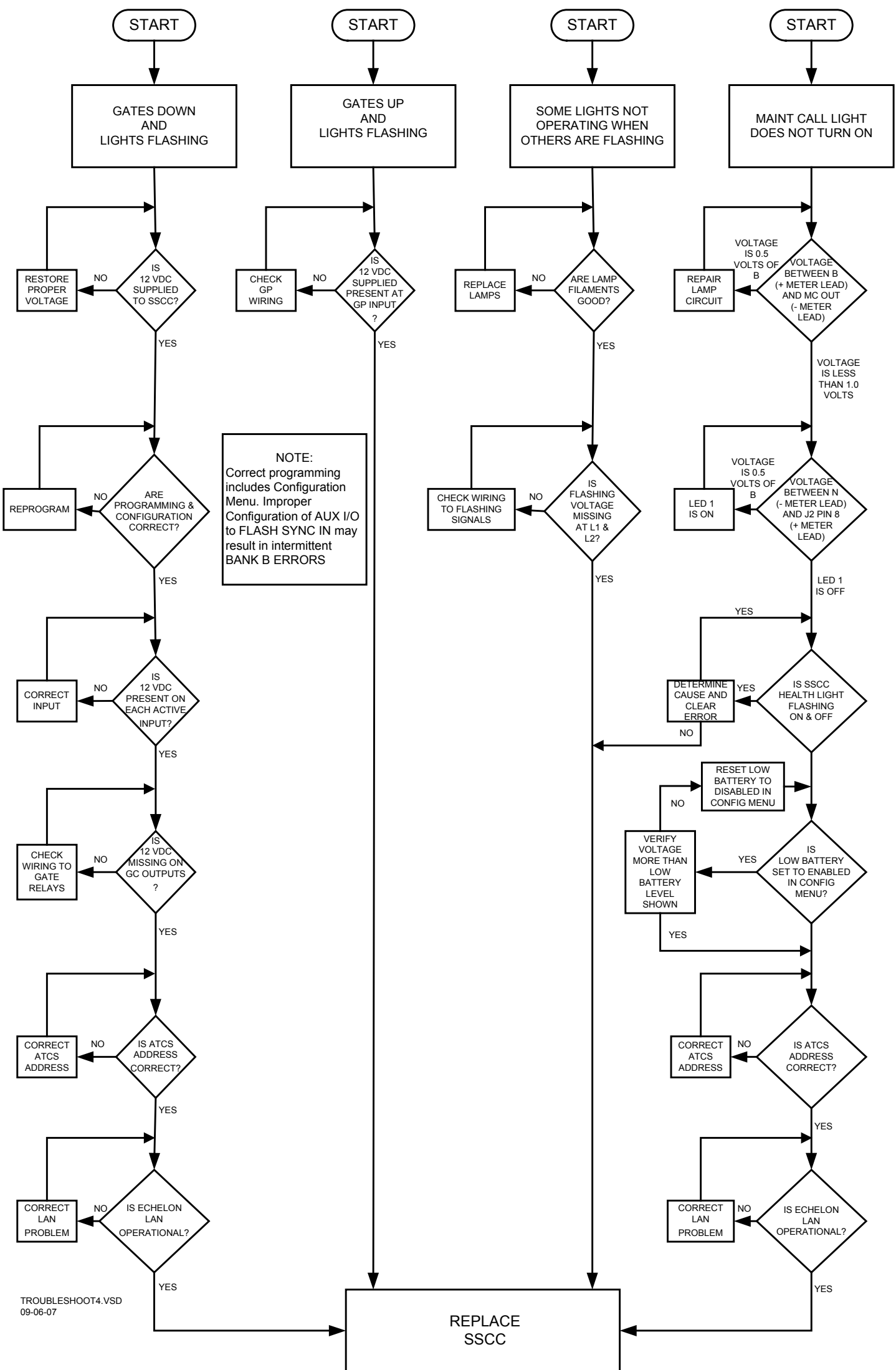

Figure 7-1: SSCC III PLUS Troubleshooting Diagram

This page intentionally left blank |

### 7.3 SSCC ERROR CODES

The SSCC is continuously self-checking its hardware and software for faults. Fault conditions may be severe or informational. When a severe fault is detected, the LCD displays a **SHUTDOWN #xxx** message where **xxx** is the Error Code. The fault is entered into the summary log. If a fault occurs repeatedly, the unit must be replaced and returned to Siemens Rail Automation Corporation under the Return Material Authorization process.

Some faults are informational faults and will not cause a SHUTDOWN; however, they are still entered into the summary log. Some faults may be correctable by user action. Table 7-1 lists those faults and the action to take.

Other messages not included in Table 7-1 may be in the summary log depending on the verbosity level setting. A higher verbosity level will generate more messages. These messages do not require user action and can be ignored. A verbosity level of 0 (minimum) is recommended. (See DT Utility for how to set the verbosity level.)

**Table 7-1: SSCC Summary Log Messages**

Sample Summary Log Messages	Shut-Down Error Code	Corrective Action
1E2 03/08/07 16:27:47.2 <b>Config is corrupt</b>	<b>143</b>	Ensure the correct MCF Name and MCF ID number is selected from the CONFIGURE menu. If error persists, replace unit and return it to Siemens Rail Automation Corporation under the Return Material Authorization process.
1E2 03/08/07 16:27:47.2 <b>Startup Check Error: 0 , MCF CRC Error</b>	<b>145</b>	
1E2 03/08/07 16:27:47.2 <b>Startup Check Error: 0 , MCF ID Number Error</b>	<b>95</b>	
1E2 03/08/07 16:27:47.2 Unconfigured. <b>Fix errors and reboot, MEF CRC: xxxxxxxx</b>	<b>147</b>	
MCF SIN Error	<b>146</b>	Configure ATCS address
1E2 03/08/07 16:27:47.2 <b>System Capability inadequate to run this MCF</b>	<b>148</b>	The selected MCF cannot be used with this unit. Select a different MCF.
1E2 03/08/07 16:27:47.2 <b>Default Cfg Options Used: Vtl User Cfg Vital</b>	<b>153</b>	Ensure the correct MCF Name and MCF ID number is selected from the CONFIGURE menu.
1E2 03/08/07 16:27:47.2 <b>Default Cfg Parm Used: Vtl Usr Tim , Slot 3, Vital</b>	<b>152</b>	
1E2 03/08/07 16:27:47.2 <b>Parameter Change Error: xxx xxxx xxxxxxxx</b>		Ensure all menu items in the PROGRAM and CONFIGURE menus are valid. If error persists, replace unit and return it to Siemens Rail Automation Corporation under the Return Material Authorization process.
1E2 03/08/07 16:27:47.2 <b>Unconfigured. Fix errors and reboot, MEF CRC:xxxxxxx</b>	<b>95</b>	
1E2 03/08/07 16:27:47.2 <b>Lamp Flash Rate Illegal: xxxxx</b>	<b>395</b>	Program the Flash rate

Table 7-1 concluded

Sample Summary Log Messages	Shut-Down Error Code	Corrective Action
1E2 03/08/07 16:27:47.2 <b>Lamp setpoint illegal:</b> x.x	<b>360</b>	Set the lamp voltage
1E2 03/08/07 16:27:47.2 <b>POWER: LOW, POWER MODULE:</b> 40A, BANK SELECT: A+B		Check power source.
1E2 03/08/07 16:27:47.2 <b>Low Battery Detected:</b> xxxx mV		
1E2 03/08/07 16:27:47.2 <b>Startup Check Error: xx, HW SW Compatibility</b>		Replace unit and return it to Siemens Rail Automation Corporation under the Return Material Authorization process.
1E2 03/08/07 16:27:47.2 <b>Capability Record invalid, defaulting to base model</b>		
1E2 03/08/07 16:27:47.2 <b>Config is corrupt</b>		
1E2 03/08/07 16:27:47.2 <b>Data flash erase error</b>	<b>308</b>	
1E2 03/08/07 16:27:47.2 <b>Data flash write error</b>	<b>309</b>	Check power source.
1E2 03/08/07 16:27:47.2 <b>VGO enable test failed</b>	<b>289</b>	
1E2 03/08/07 16:27:47.2 <b>VGO frequency error</b>	<b>290</b>	
1E2 03/08/07 16:27:47.2 <b>Slave Error x: Chnl: x , xxxxxx xxx</b>	<b>302</b>	
1E2 03/08/07 16:27:47.2 <b>Reboot Occurred (RSR xx ), xxxxxxxx xxxx</b>		If error persists, replace unit and return it to Siemens Rail Automation Corporation under the Return Material Authorization process.
1E2 03/08/07 16:27:47.2 <b>EVENT DATA CORRUPT, DATA UNAVAILABLE</b>		Clear the event Log
1E2 03/08/07 16:27:47.2 ATCS Rx session lost		If occurs repeatedly, check the communication link.
1E2 03/08/07 16:27:47.2 ATCS Tx session lost		
DT Queue Full	<b>102</b>	Make sure PC baud rate is correct and cable is OK
1E2 03/08/07 16:27:47.2 <b>LAN Shutdown</b>	<b>105</b>	Insure LAN wired per user manual and cabling is OK.
LAN errors	<b>103, 104, 105, 107</b>	
1E2 03/08/07 16:27:47.2 <b>Processor communication error, Unable to communicate with slave processor</b>	<b>394</b>	Replace unit and return it to Siemens Rail Automation Corporation under the Return Material Authorization process.

#### 7.4 LAMP NEUTRAL WIRE OPEN

If a **LAMP NEUTRAL WIRE OPEN** message periodically appears on the LCD display and the open neutral wire connection has been corrected, the unit's **HEALTH** indication and the **MAINT CALL**

output status can be restored by momentarily selecting **TST ACTIVATE XNG** from the **TEST** menu (**Warning: the crossing will activate when TST ACTIVATE XING is selected**).

**NOTE****NOTE**

The power supplies in many LED signals adversely affect the Open Lamp Neutral circuitry. Disable (set to NO) DETECT LAMP NEUTRAL WIRE when LEDs are used on any lamp output.

## 7.5 Troubleshooting Maintenance Call (MC) Light Problems

Several operations in the SSCC system will turn-off the MAINT CALL (MC) light. This procedure assumes:

- The warning devices are not activated and SSCC unit is healthy.
- No track is out-of-service (A track OOS turns off the MC light)
- MC operation is being placed in service for the first time and wiring must be checked.

### 7.5.1 MCF files that effect the Maintenance Call (MC) Lights

When the parameters listed in Table 7-2 are energized via the Menus, the MC lights will not illuminate. Before beginning Troubleshooting procedures, ensure that the parameters depicted in Table 7-2 are not the cause of the MC Light being out.

Verify the status of the listed parameters prior to performing normal troubleshooting procedures for the listed MCF's.

**Table 7-2: MCF / MC Light-Out Cross Reference Chart**

<b>MCF</b>	<b>SSCC Unhealthy</b>	<b>Low Battery, if Low Battery Detection enabled</b>	<b>Lost Echelon with another vital controller</b>	<b>Track taken out of service</b>
BASIC	X	X		
BASICPLS	X	X		X
3TRK1WRP	X	X		X
2TRK2WRP	X	X		X
2TRKDSTK	X	X		X
SUPISL	X	X		X
3TRK2TRN	X	X		X
2TRK2TRN	X	X		X
DAXPRMPT	X	X		X

### 7.5.2 Troubleshooting Procedure for Maintenance Call (MC) Light Problems

The following procedure checks the most common items first. If the MAINT CALL light does not turn on after a step, proceed to the next step.

1. Observe MAINT CALL LED on Connector J2
  - If LED 1 is on, go to step 2.
  - If LED 1 is off, go to step 3.

2. Determine that the MC light functions by testing the lamp circuit as follows:
  - a. Measure DC voltage between **B** (+ meter lead) and **MAINT CALL** (MC) out (- meter lead) on the green connector J2.
    - ♦ If voltage is within 0.5 volts of B, then the lamp or lamp circuit is open and must be repaired.
    - ♦ If voltage is less than 1.0 volts, go to next step.
  - b. Measure between **N** (- meter lead) and **MC** (+ meter lead) on the green connector.
    - ♦ If voltage is within 0.5 volts of B, then the lamp circuit is okay, but the MC output is off.
      - ✧ If LED 1 is on, replace SSCC
      - ✧ If LED 1 is off, go to the next step
3. If the SSCC health light is flashing rapidly or off, determine cause or replace SSCC.
4. Battery voltage may be low:
  - If **Low Battery** is set to **Enabled** in Configuration Menu, verify that the voltage on the battery connector is more than the **Low Battery Level** shown.

If, after following the steps above, the MC lamp stays off, call Siemens Rail Automation Technical Support for further assistance at (800) 793-7233.



## SECTION 8 EXTERNAL COMMUNICATION

### 8.1 GENERAL

The SSCC III PLUS can communicate with external equipment through two means: Echelon® LAN interface, and RS-232 serial interface.

### 8.2 LAN

The SSCC III PLUS is capable of communicating with external equipment using the Echelon® LAN interface. A typical application is to use Safetran's SEAR II, part number A80273, to record all SSCC III PLUS events. By connecting via the LAN, all events can be recorded on the SEAR II.

A valid ATCS address (refer to Section 4.2.2.3) must be programmed into the SSCC III PLUS. The SEAR II, connected via the LAN to the SSCC III PLUS, must be programmed with the ATCS address of the SSCC III PLUS.

The ATCS address is formatted as follows: 7.RRR.LLL.GGG.SS

Where:

**7** is the designation for ATCS wayside type addressing,

**RRR** is the Railroad number,

**LLL** is the Line number,

**GGG** is the Group number,

**SS** is the subnode number (must be greater than 02).

Connect the SSCC III PLUS LAN terminals of J4 (polarity is arbitrary) to the ECH terminals of connector J1 of the SEAR II (figure 8-1).

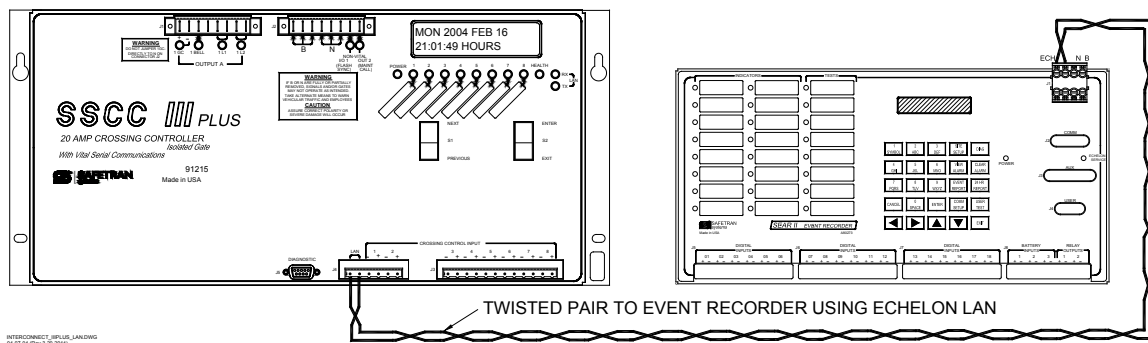

**Figure 8-1. SSCC III PLUS to SEAR II Using LAN**

#### NOTE

#### NOTE

SSCC MEF software revision 9V546.A06.H or above requires SEAR II MEF software revision 9V645.A01.G or above to establish communications.

### 8.3 RS-232 DIAGNOSTIC PORT J5

The RS-232 Diagnostic port (J5) is configured as DCE, to communicate with a diagnostic terminal or other DTE such as an SEA/R. The following paragraphs give some options for using the serial port.

#### NOTE

**NOTE**  
Currently, SEAR II does not have the capability to communicate with an SSCC III PLUS via serial port.

#### 8.3.1 SSCC III PLUS Serial Port To PC

By connecting the Diagnostic port to a laptop PC running the Safetran<sup>®</sup> DT (Diagnostic Terminal) utility (refer to figure 8-2), the user is able to load software, change system parameters, review configuration data and site specific data, set date and time, monitor and troubleshoot the system, send ATCS requests and receive ATCS replies to/from local or remote equipment, and request and store event data for use with a data analyzer. Use of the DT is described in Safetran Document # SIG-00-01-14.

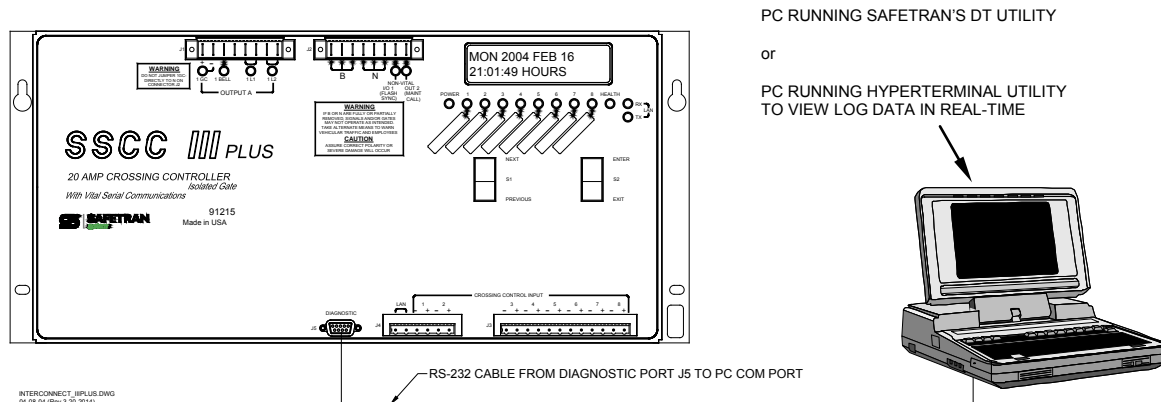

**Figure 8-2. SSCC III PLUS Serial Port To PC COM Port**

There may be instances when data being logged needs to be transferred to a terminal or laptop computer in order to review data (such as remotely from the office). When the SSCC III PLUS unit's Diagnostic port J5 (refer to figure 8-2) is connected to a PC running terminal emulation, the events are displayed in real-time on the screen, oldest events being replaced by newest.

There are many different text capture methods available, however the following procedure is for using HyperTerminal, a Windows<sup>™</sup> based PC Terminal Emulation utility:

1. Connect the PC's COM1 port to the SSCC III PLUS Diagnostic port, using an RS232 straight-through (pin to socket) cable (refer back to figure 8-2).

2. At the PC, click on the **Start** button on the taskbar, and go to **Programs\ Accessories\ Communications\ HyperTerminal**.
3. When the HyperTerminal **Connection Description** dialog box appears, type the name of the destination file for the connection configuration data (e.g., **Temp1**), select an icon for the connection, and click on **OK**.
4. In the **Connect To** dialog box, leave **Phone Number** blank, move the cursor to the **Connect Using:** box, and using the scrollbar, select **COM1**, then click on **OK**.
5. In the **Com1 Properties** dialog box, make the following selections, then click on **OK**:
  - a. Bits per second: 9600
  - b. Data bits: 8
  - c. Parity: None
  - d. Stop bits: 1
  - e. Flow control: None
6. Events will be displayed in real-time.

Refer to the example log and explanation in figure 8-3.

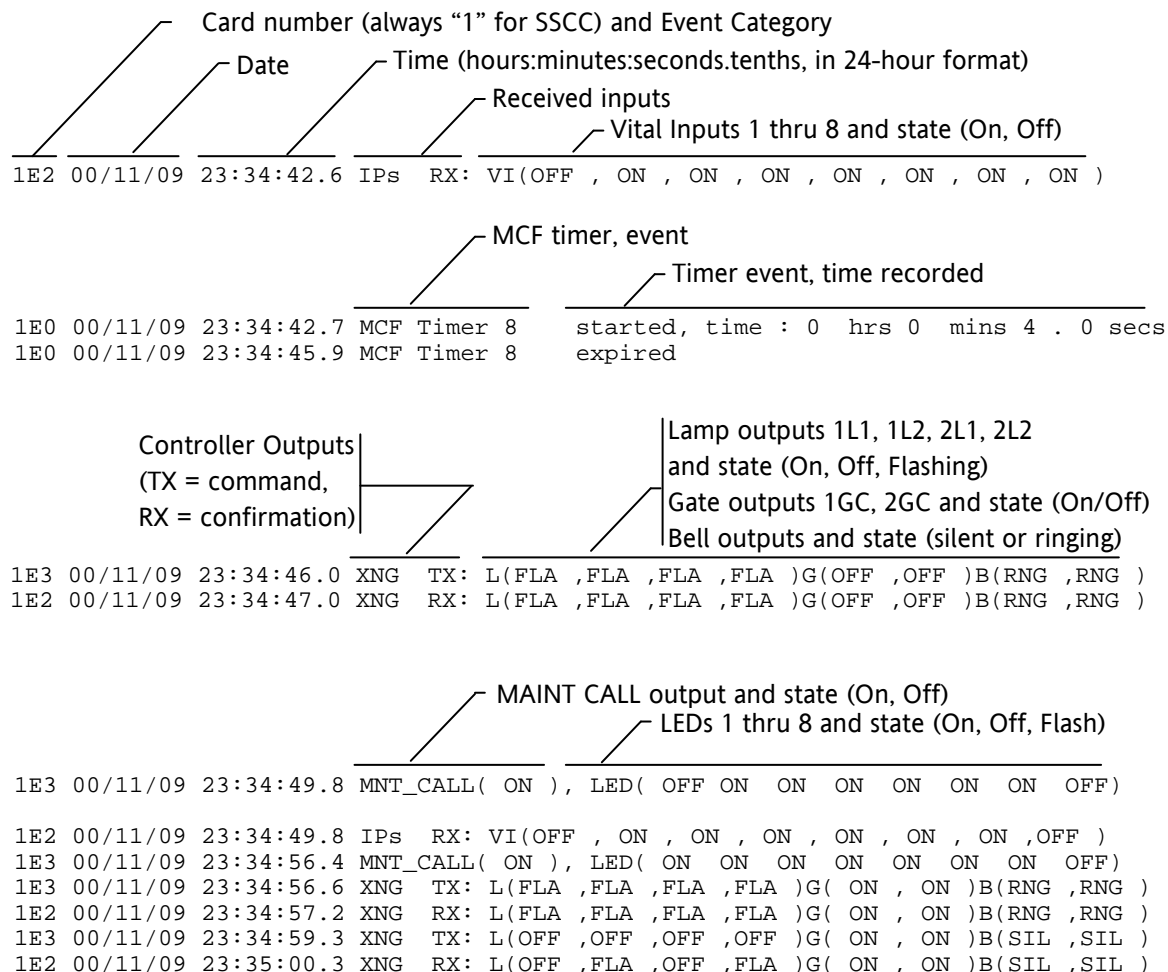

**Figure 8-3. Example Log Data on a PC**

### 8.3.2 SSCC III PLUS Serial Port To SEA/R

The SSCC III PLUS contains memory for recording events. Designed as a diagnostic tool, the memory space is large enough to record approximately 8 train moves. By connecting the SSCC III PLUS to an Event Analyzer/Recorder such as Safetran's SEA/R, part number A80250, all events can be recorded. Connect the SSCC III PLUS 9-pin Diagnostic port J5 (refer to figure 8-4) to the SEA/R 25-pin Radio/Modem port J1 or J2, using an RS232 male-to-male cable (or use a gender changer), or optionally connect the units' LAN ports. For instructions on using the SEA/R, refer to the Installation & Operation manual, Safetran Document # SIG-00-98-04, for Safetran Event Analyzer/Recorder (SEA/R) A80250.

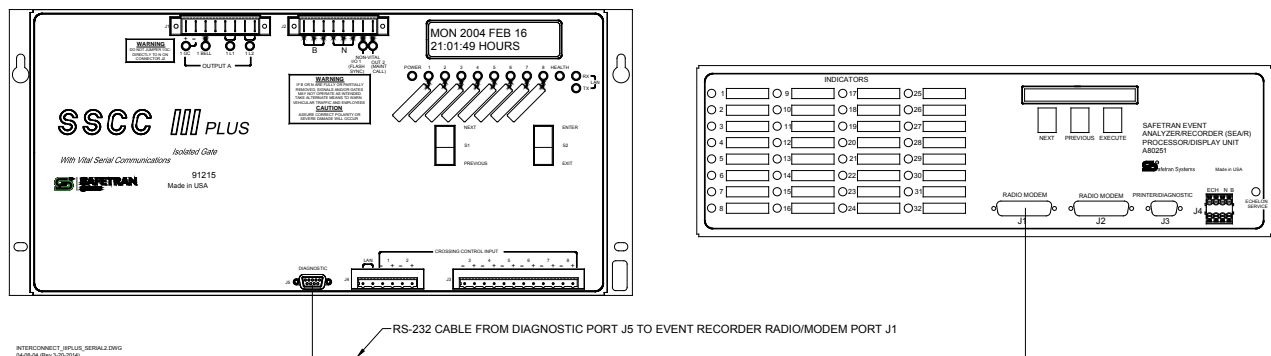

**Figure 8-4. SSCC III PLUS Serial Port to SEA/R**

**NOTE**

**NOTE**  
 In order to communicate with an SEA/R (part number A80250) by LAN, the software level installed in the SEA/R must be ER30 or higher and the MIP (Microprocessor Interface Program) software must be 9V146A01.B or higher.

## SECTION 9

### SOFTWARE VERIFICATION & UPGRADE

#### 9.1 GENERAL

Siemens Rail Automation Corporation may release enhanced application software for the Solid-State Crossing Controller III PLUS (SSCC III PLUS), if required.

#### 9.2 SOFTWARE UPGRADE



##### WARNING

**WHILE UPDATING SOFTWARE, THE CROSSING GATES ARE DOWN WITH LAMPS FLASHING AND BELLS RINGING (REGARDLESS OF THE STATE OF THE VITAL CROSSING CONTROL INPUTS). TAKE ADEQUATE PRECAUTIONS TO WARN PERSONNEL, PEDESTRIANS, TRAINS AND OTHER VEHICLES IN THE AREA UNTIL PROPER SYSTEM OPERATION HAS BEEN VERIFIED.**

If software needs to be installed, Safetran's DT (Diagnostic Terminal utility) must be available on the computer used for installing the software.

Safetran document # SIG-00-01-14 provides detailed information on using the DT software, running on a laptop or desktop PC, to install software.

#### 9.3 SOFTWARE VERIFICATION

The MEF (Master Executable File) version resident in the SSCC III PLUS is displayed on the LCD display during system boot-up. The software version is the second message displayed during the power-up cycle.

The software versions can be queried from the crossing controller front panel at any time by using the Query menu system (refer to Section 4 for the Query menu). The MEF version and the MCF name can be viewed by using the DT utility View menu, "CPU Version" option. (See Appendix A for MCF revision history.)

The following paragraphs contain general instructions for verifying software versions in the SSCC III PLUS.

### 9.3.1 Query Menu

The Query menu (refer to Section 4 for menu flow diagram) consists of the following programming items (submenus):

- Query Software Versions (paragraph 9.3.1.1)
- Query Config Versions (paragraph 9.3.1.2)
- Exit Query (paragraph 9.3.1.3)

#### NOTE

#### NOTE

Query mode does not require a password.

#### NOTE

#### NOTE

A timeout function is in effect when in query mode. If 90 seconds elapse without front panel switch activity, the display reverts to the idle screen.

#### 9.3.1.1 Query Software Versions

To query software versions, perform the following steps:

1. Scroll through the main menu using NEXT or PREVIOUS until **QUERY** is displayed, then press <ENTER>.
2. The default query option is displayed (**QUERY SOFTWARE VERSIONS**).
3. Press <ENTER> again. The MEF version (default option) is displayed along with its CRC (see below for a typical example).

```
MEF:9V546A01.K
CRC: 577981CE
```

4. Press <NEXT> to display the Master boot file (MBT).
5. Press <NEXT> or <PREVIOUS> to scroll to other software versions. Possible selections are:

MEF:	Master executable file
MBT:	Master boot file
SEF1 – SEF4:	Slave executable file
SBT1 – SBT4:	Slave boot file

#### NOTE

#### NOTE

SEF3, SEF4, SBT3, and SBT4 are displayed only for the 40-Amp unit (non-existent for the 20-Amp unit).

### 9.3.1.2 Query Configuration Versions

To query configuration versions, perform the following steps:

1. Scroll through the main menu using NEXT or PREVIOUS until **QUERY** is displayed, then press <ENTER>.
2. The default query option is displayed (**QUERY SOFTWARE VERSIONS**).
3. Press <NEXT>. The second option, **QUERY CONFIG VERSIONS** is displayed.



QUERY CONFIG  
VERSIONS

4. Press <ENTER>. **MCF NAME:** is displayed followed by the filename and revision.



MCF NAME:  
supisl.mcf.F

5. Press <NEXT>. **MCF CRC:** is displayed followed by the 8-digit hexadecimal number.

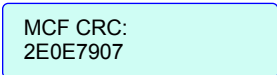

MCF CRC:  
2E0E7907

6. Press <NEXT>. **CAPABILITY NAME:** is displayed followed by the software number and version.

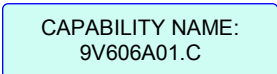

CAPABILITY NAME:  
9V606A01.C

7. Press <NEXT>. **EXIT DATA VERSIONS** is displayed.



EXIT DATA  
VERSIONS

8. Press <ENTER> or <EXIT> to return to the **QUERY CONFIG VERSIONS** menu in the QUERY menu, or press <NEXT> to return to **MCF NAME**.

### 9.3.1.3 Exit Query Mode

To exit query mode and return to the main menu (**QUERY** option), press <EXIT>, or scroll to **EXIT QUERY** and press either <EXIT> or <ENTER>.

This page intentionally left blank



## **SECTION 10 APPLICATION DRAWINGS**

### **10.1 GENERAL**

This section contains typical application drawings for the SSCC III PLUS.

This page intentionally left blank

This page intentionally left blank

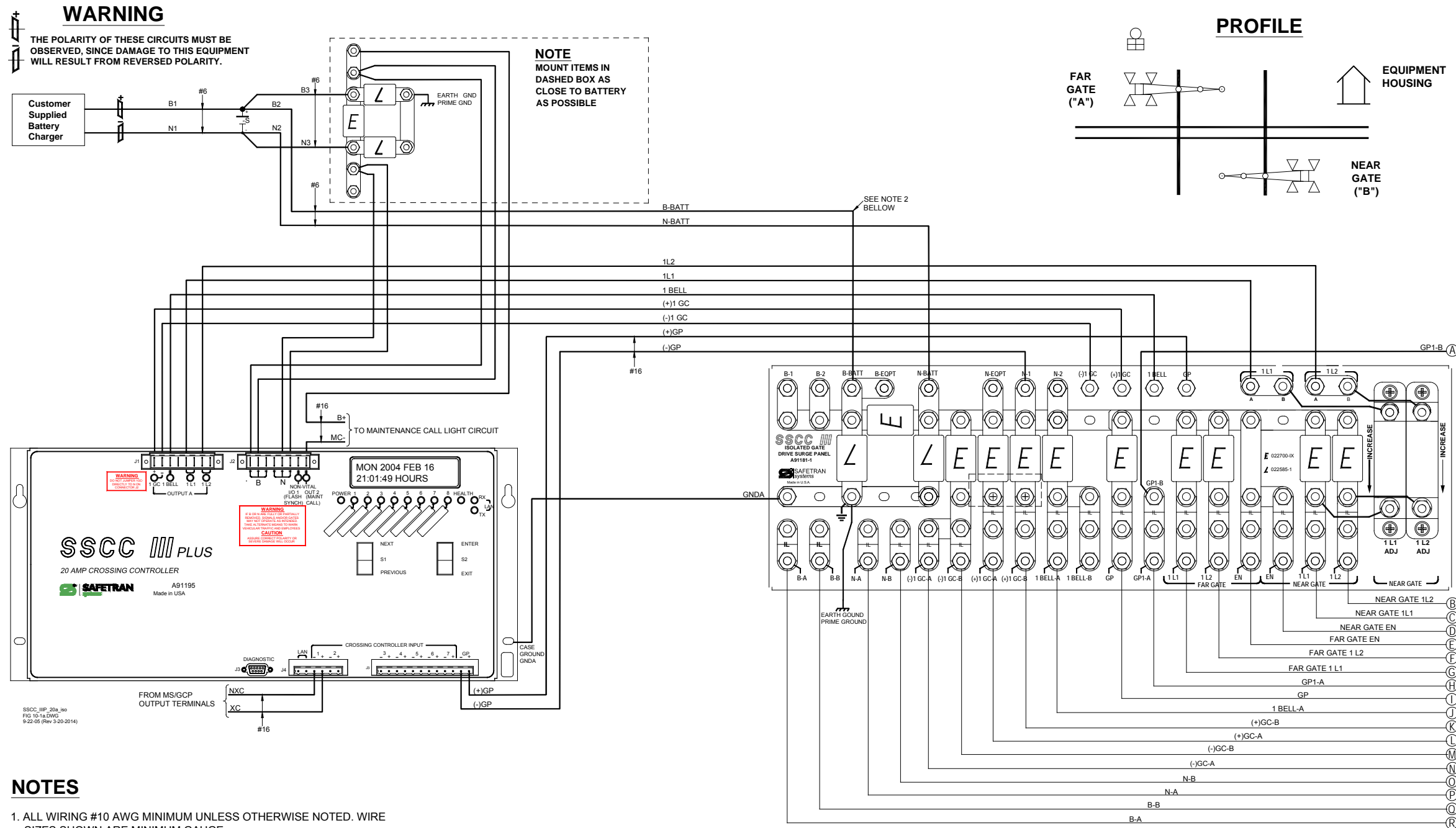

**NOTES**

1. ALL WIRING #10 AWG MINIMUM UNLESS OTHERWISE NOTED. WIRE SIZES SHOWN ARE MINIMUM GAUGE.
2. THIS CONNECTION NOT REQUIRED IF GATES ARE NOT USED.
3. THE FOLLOWING SURGE PANEL SYMBOLS ARE USED:  
 E = 022700-1X EQUALIZER  
 L = 022585-1 ARRESTER CLEARVIEW H. D.  
 IL = INSULATED TESTING LINK

**Figure 10-1: Typical Two-Gate Application (Isolated Gate Return) using 20-Ampere Crossing Controller With Lightning/Surge Panel A91181-1 (Page 1 of 2)**

APPLICATION DRAWINGS

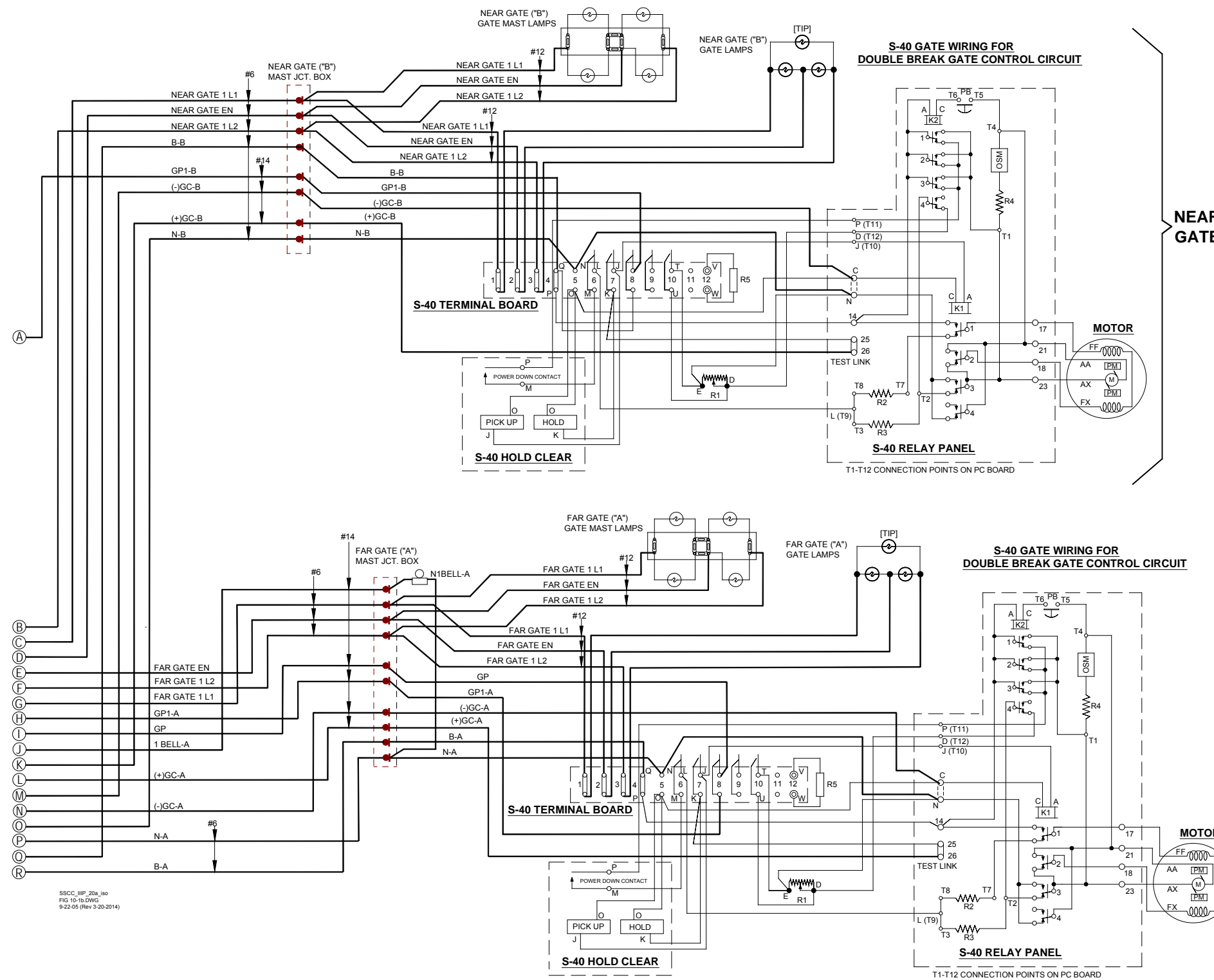

SSCC\_HIP\_20a\_iso  
FIG 10-7a.DWG  
9-22-05 (Rev 3-20-2014)

NOTES

1. ALL WIRING #10 AWG MINIMUM UNLESS OTHERWISE NOTED. WIRE SIZES SHOWN ARE MINIMUM GAUGE.
2. ON THE SAME SURGE PANEL, THE 'FAR GATE' IS THE FLASHING LIGHT SIGNAL OR GATE WITH THE LARGEST VOLTAGE DROP IN THE CABLE CIRCUIT. IN GENERAL, IF BOTH SIGNALS HAVE THE SAME NUMBER AND TYPE OF LAMPS AND THE SAME SIZE CABLE CONDUCTORS, THE 'FAR GATE' IS THE LOCATION WITH THE LONGEST CABLE RUN. THE 'NEAR GATE' CIRCUIT ON THE SURGE PANEL HAS AN ADJUSTABLE RESISTOR IN SERIES WITH L1 AND L2 THAT PROVIDES VOLTAGE ADJUSTMENT.

RELAY PANEL TERMINAL LAYOUT

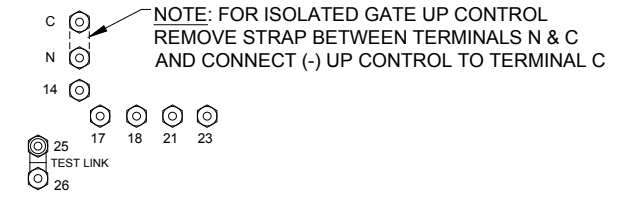

CONTACTS CLOSED & FUNCTION

- (SHOWN WITH GATE UP)
6. 45° - 90° POWER DOWN
  7. 0° - 89° POWER UP
  8. 83° - 90° FLASHING LIGHT
  9. 5° - 90° BELL
  10. 0° - 5° HORIZONTAL SNUB

S-40 GATE COMPONENTS

- R1 - DOWN SNUB RESISTOR, ADJ.
- R2 - POWER DOWN RATE RESISTOR
- R3 - POWER DOWN LIMIT RESISTOR
- R4 - OSM SNUB RESISTOR
- R5 - DEFROSTER
- K1 - GATE RELAY
- K2 - MAINT. SWITCH RELAY
- OSM - OVERSPEED MODULE

Figure 10-2: Typical Two-Gate Application (Isolated Gate Return) using 20-Ampere Crossing Controller With Lightning/Surge Panel A91181-1 (Page 2 of 2)

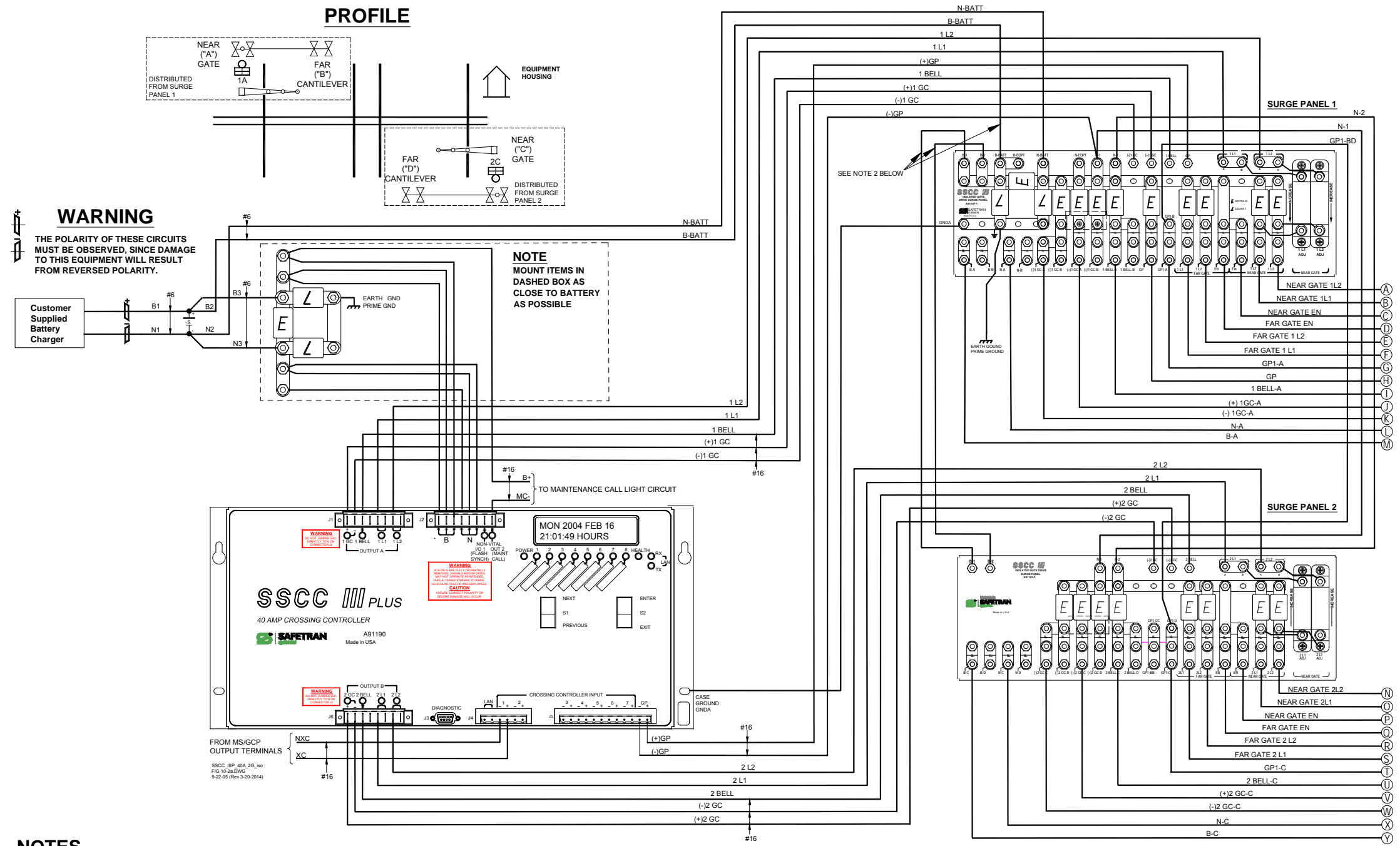

**NOTES**

1. ALL WIRING #10 AWG MINIMUM UNLESS OTHERWISE NOTED. WIRE SIZES SHOWN ARE MINIMUM GAUGE.
2. THESE CONNECTIONS NOT REQUIRED IF GATES ARE NOT USED.
3. THE FOLLOWING SURGE PANEL SYMBOLS ARE USED:  
 E = 022700-1X EQUALIZER  
 L = 022585-1 ARRESTER CLEARVIEW H. D.  
 IL = INSULATED TESTING LINK

**Figure 10-3: Typical Two-Gate Application (Isolated Gate Return) With Cantilever Flashers, 40-Ampere Crossing Controller With Lighting/Surge Panels A91181-1 and A91181-2 (Page 1 of 2)**

APPLICATION DRAWINGS

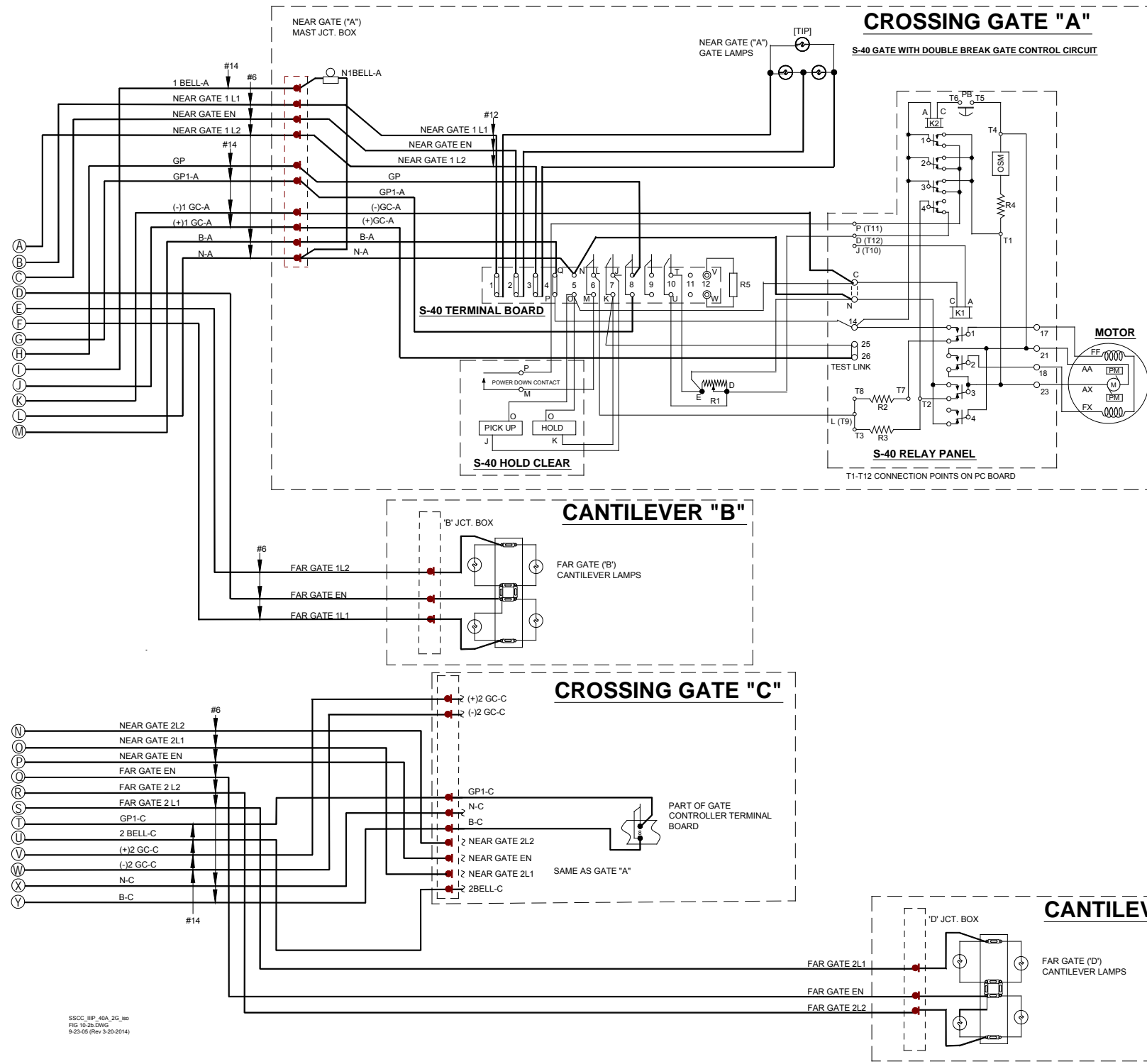

NOTES

1. ALL WIRING #10 AWG MINIMUM UNLESS OTHERWISE NOTED. WIRE SIZES SHOWN ARE MINIMUM GAUGE.
2. ON THE SAME SURGE PANEL, THE 'FAR GATE' IS THE FLASHING LIGHT SIGNAL OR GATE WITH THE LARGEST VOLTAGE DROP IN THE CABLE CIRCUIT. IN GENERAL, IF BOTH SIGNALS HAVE THE SAME NUMBER AND TYPE OF LAMPS AND THE SAME SIZE CABLE CONDUCTORS, THE 'FAR GATE' IS THE LOCATION WITH THE LONGEST CABLE RUN. THE 'NEAR GATE' CIRCUIT ON THE SURGE PANEL HAS AN ADJUSTABLE RESISTOR IN SERIES WITH L1 AND L2 THAT PROVIDES VOLTAGE ADJUSTMENT.

RELAY PANEL TERMINAL LAYOUT

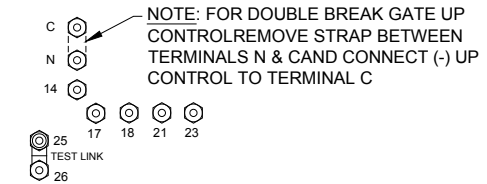

CONTACTS CLOSED & FUNCTION

- (SHOWN WITH GATE UP)
6. 45°- 90° POWER DOWN
  7. 0°-89° POWER UP
  8. 83°- 90° FLASHING LIGHT
  9. 5°- 90° BELL
  10. 0°- 5° HORIZONTAL SNUB

S-40 GATE COMPONENTS

- R1 - DOWN SNUB RESISTOR, ADJ.
- R2 - POWER DOWN RATE RESISTOR
- R3 - POWER DOWN LIMIT RESISTOR
- R4 - OSM SNUB RESISTOR
- R5 - DEFROSTER
- K1 - GATE RELAY
- K2 - MAINT. SWITCH RELAY
- OSM - OVERSPEED MODULE

Figure 10-4: Typical Two-Gate Application (Isolated Gate Return) With Cantilever Flashers, 40-Ampere Crossing Controller With Lighting/ Surge Panels A91181-1 and A91181-2 (Page 2 of 2)

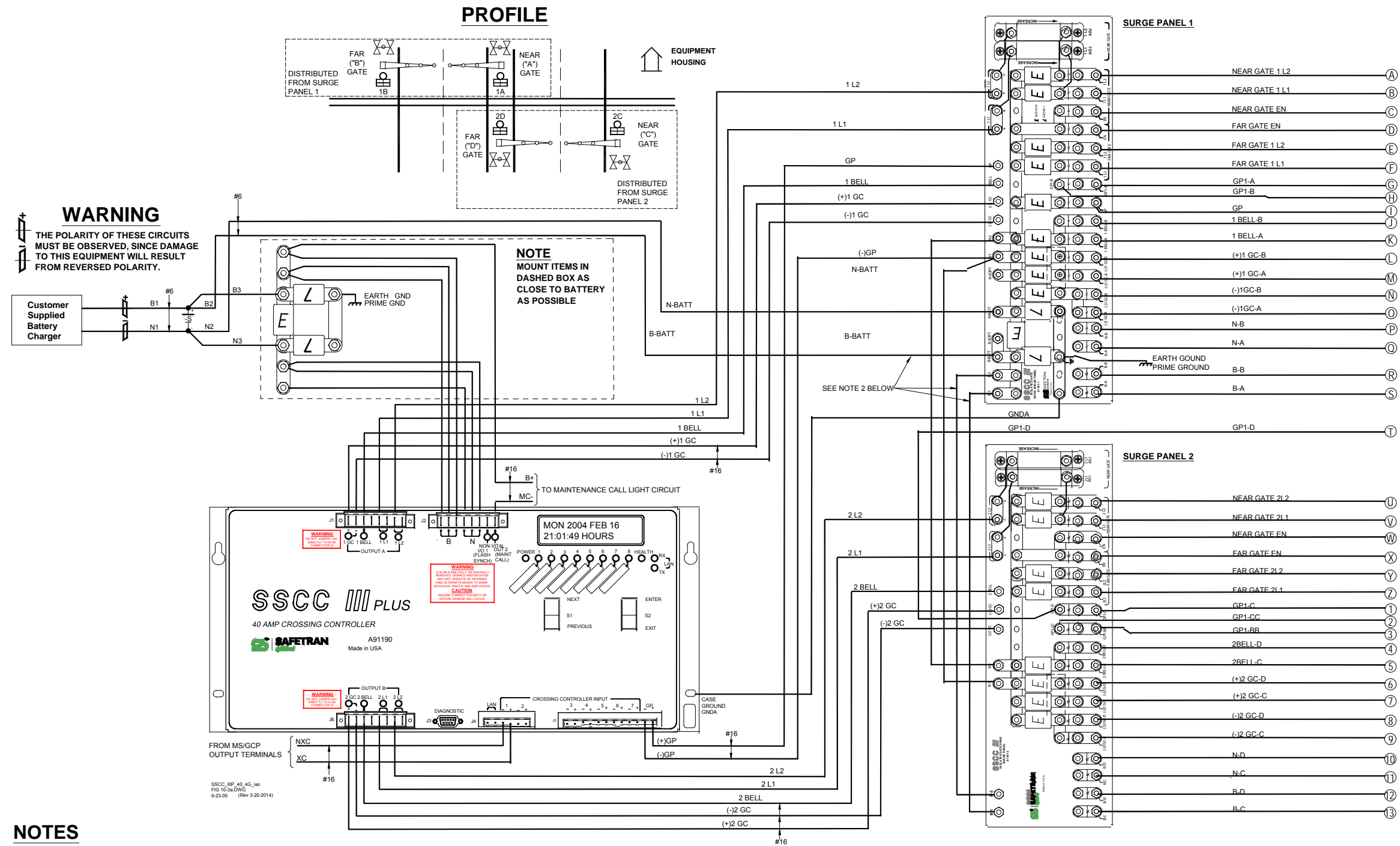

**NOTES**

1. ALL WIRING #10 AWG MINIMUM UNLESS OTHERWISE NOTED. WIRE SIZES SHOWN ARE MINIMUM GAUGE.
2. THESE CONNECTIONS NOT REQUIRED IF GATES ARE NOT USED.

3. THE FOLLOWING SURGE PANEL SYMBOLS ARE USED:

- E = 022700-1X EQUALIZER
- L = 022585-1 ARRESTER CLEARVIEW H. D.
- IL = INSULATED TESTING LINK

**Figure 10-5: Typical Four-Gate Application (Isolated Gate Return) Using 40-Ampere Crossing Controller With Lighting/Surge Panels A91181-1 And A91181-2 (Page 1 of 2)**



APPLICATION DRAWINGS

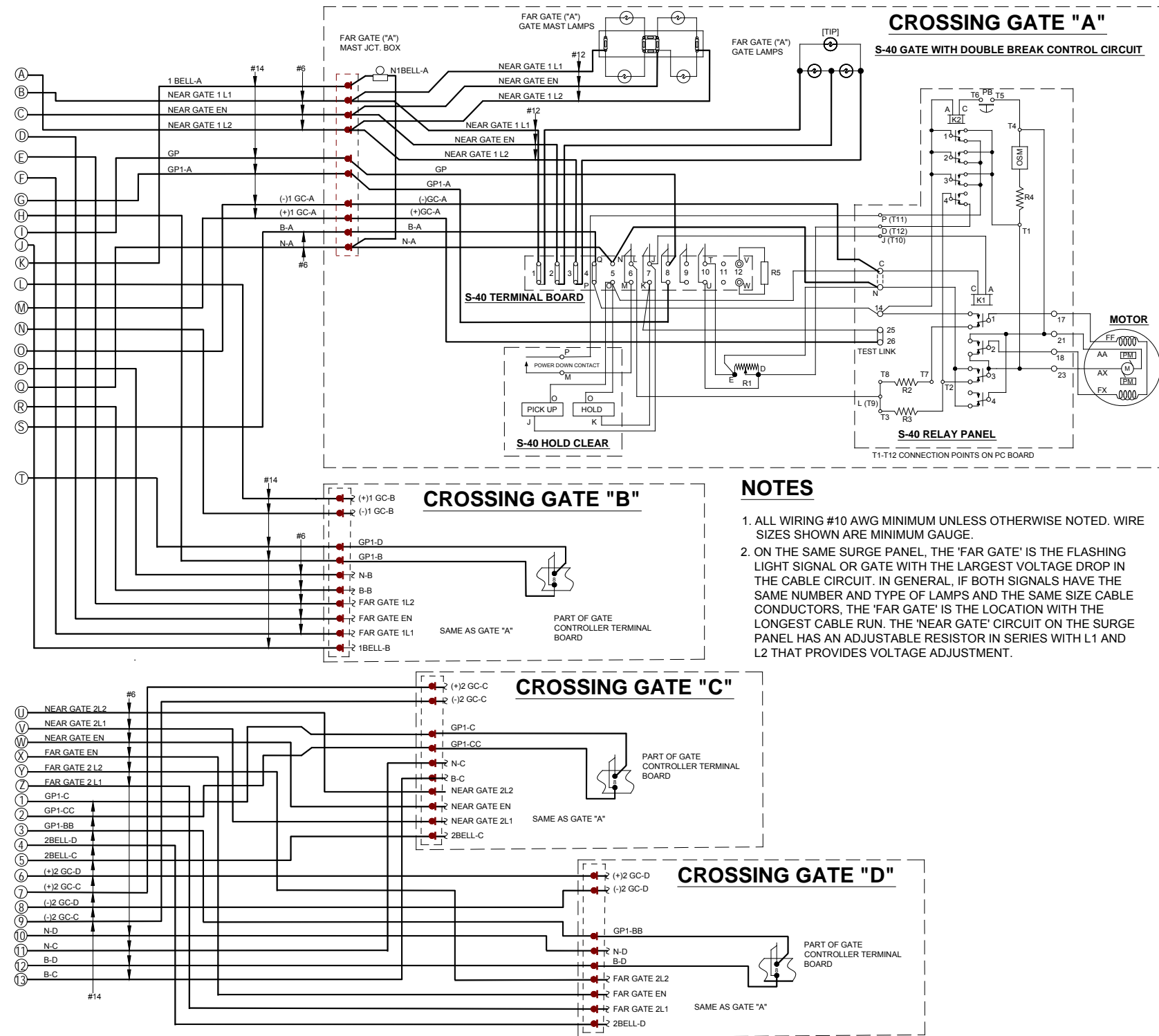

NOTES

1. ALL WIRING #10 AWG MINIMUM UNLESS OTHERWISE NOTED. WIRE SIZES SHOWN ARE MINIMUM GAUGE.
2. ON THE SAME SURGE PANEL, THE 'FAR GATE' IS THE FLASHING LIGHT SIGNAL OR GATE WITH THE LARGEST VOLTAGE DROP IN THE CABLE CIRCUIT. IN GENERAL, IF BOTH SIGNALS HAVE THE SAME NUMBER AND TYPE OF LAMPS AND THE SAME SIZE CABLE CONDUCTORS, THE 'FAR GATE' IS THE LOCATION WITH THE LONGEST CABLE RUN. THE 'NEAR GATE' CIRCUIT ON THE SURGE PANEL HAS AN ADJUSTABLE RESISTOR IN SERIES WITH L1 AND L2 THAT PROVIDES VOLTAGE ADJUSTMENT.

RELAY PANEL TERMINAL LAYOUT

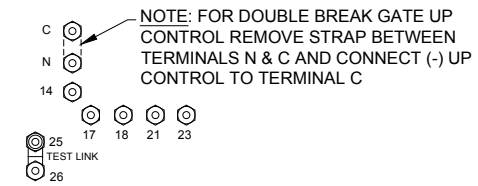

CONTACTS CLOSED & FUNCTION

- (SHOWN WITH GATE UP)
6. 45° - 90° POWER DOWN
  7. 0° - 89° POWER UP
  8. 83° - 90° FLASHING LIGHT
  9. 5° - 90° BELL
  10. 0° - 5° HORIZONTAL SNUB

S-40 GATE COMPONENTS

- R1 - DOWN SNUB RESISTOR, ADJ.
- R2 - POWER DOWN RATE RESISTOR
- R3 - POWER DOWN LIMIT RESISTOR
- R4 - OSM SNUB RESISTOR
- R5 - DEFROSTER
- K1 - GATE RELAY
- K2 - MAINT. SWITCH RELAY
- OSM - OVERSPEED MODULE

SSCC\_IPP\_40\_4G\_00  
FIG 10-36.DWG  
9-23-01 (REV 9-20-2014)

Figure 10-6: Typical Four-Gate Application (Isolated Gate Return) Using 40-Ampere Crossing Controller With Lighting/ Surge Panels A91181-1 And A91181-2 (Page 2 of 2)

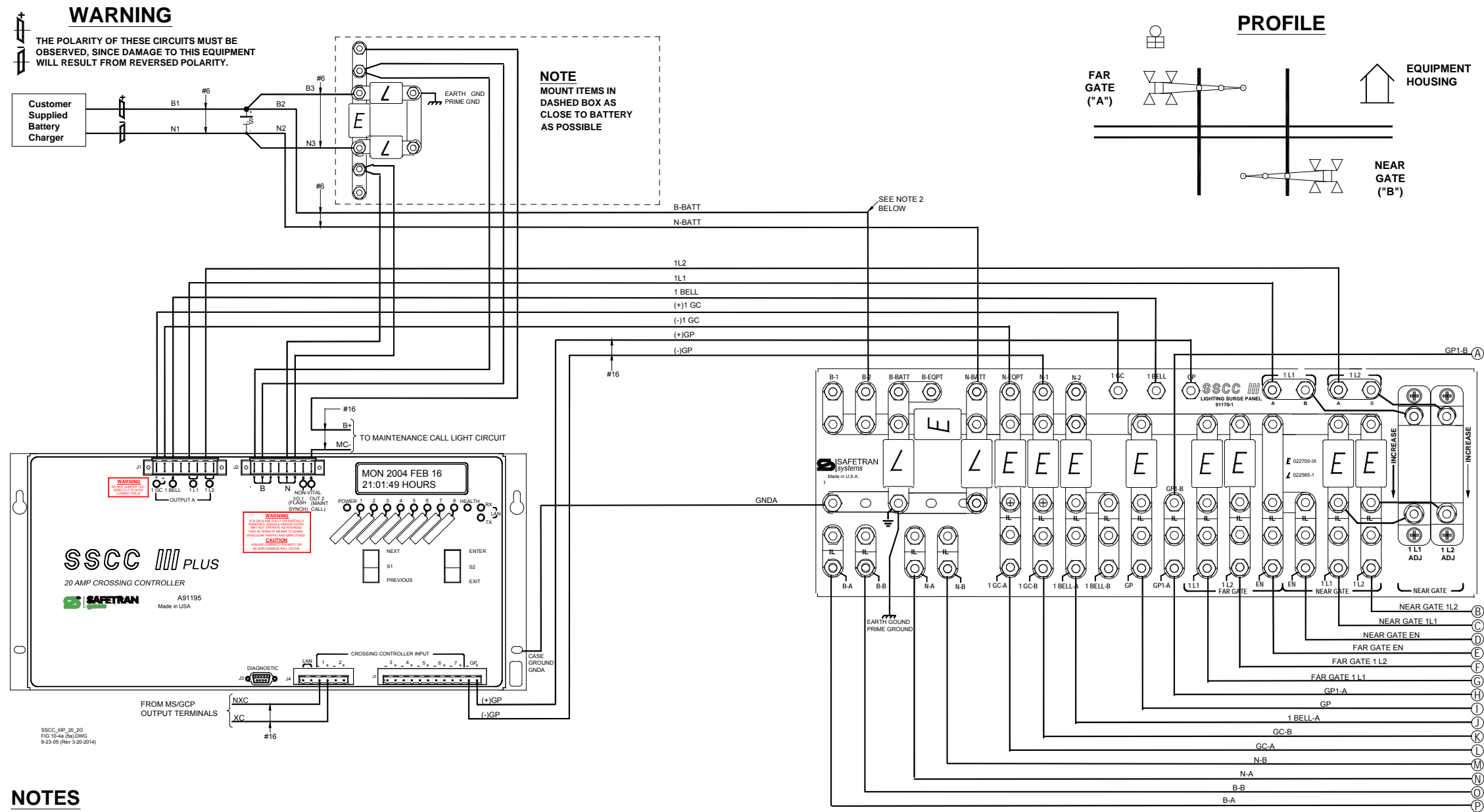

**NOTES**

1. ALL WIRING #10 AWG MINIMUM UNLESS OTHERWISE NOTED. WIRE SIZES SHOWN ARE MINIMUM GAUGE.
2. THIS CONNECTION NOT REQUIRED IF GATES ARE NOT USED.
3. THE FOLLOWING SURGE PANEL SYMBOLS ARE USED:  
 E = 022700-1X EQUALIZER  
 L = 022585-1 ARRESTER CLEARVIEW H. D.  
 IL = INSULATED TESTING LINK

**Figure 10-7: Typical Two-Gate Application (Common Gate Return) Using 20-Ampere Crossing Controller With Lighting/Surge Panel A91170-1 (Page 1 of 2)**

APPLICATION DRAWINGS

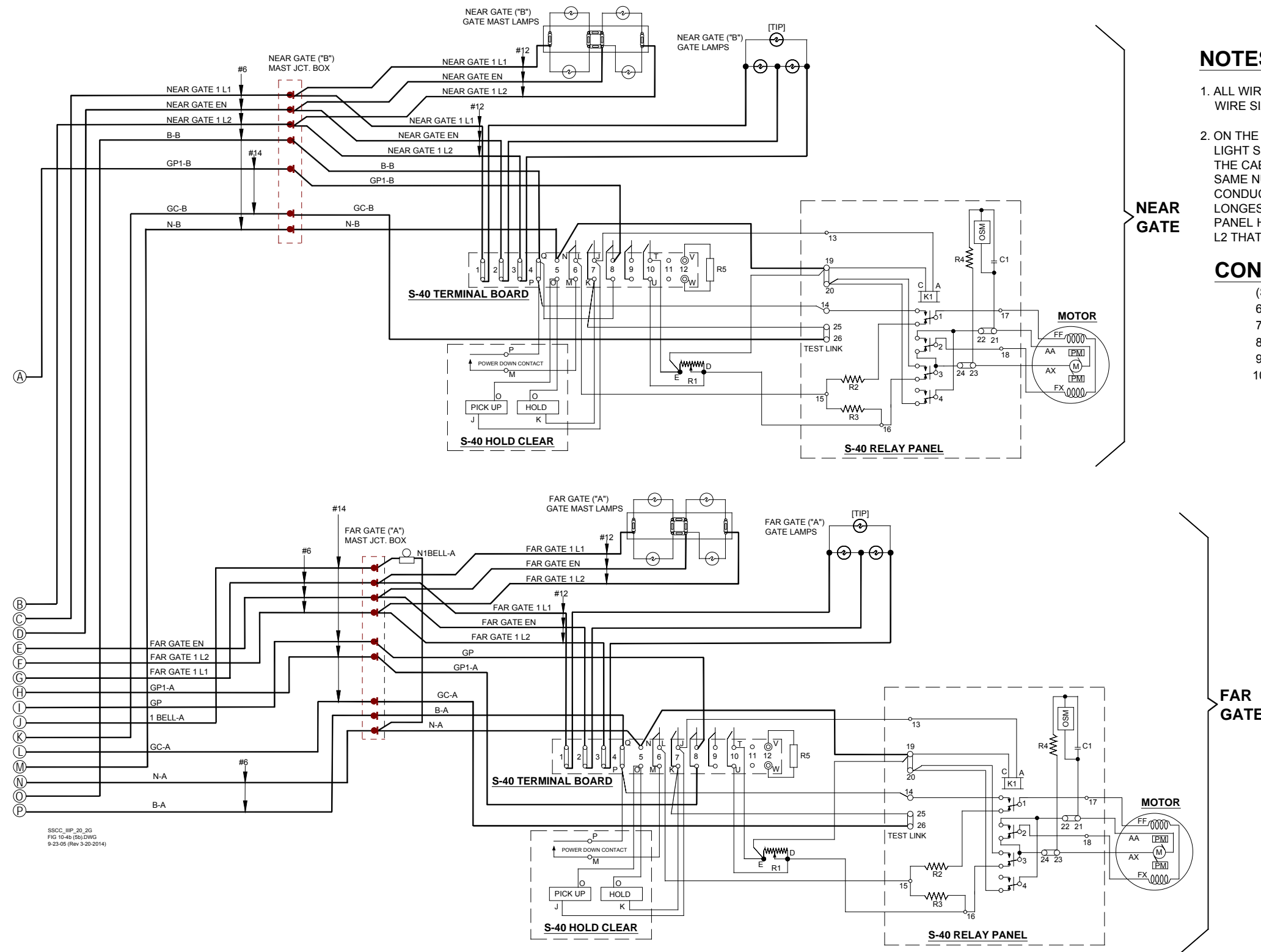

**NOTES**

1. ALL WIRING #10 AWG MINIMUM UNLESS OTHERWISE NOTED. WIRE SIZES SHOWN ARE MINIMUM GAUGE.
2. ON THE SAME SURGE PANEL, THE 'FAR GATE' IS THE FLASHING LIGHT SIGNAL OR GATE WITH THE LARGEST VOLTAGE DROP IN THE CABLE CIRCUIT. IN GENERAL, IF BOTH SIGNALS HAVE THE SAME NUMBER AND TYPE OF LAMPS AND THE SAME SIZE CABLE CONDUCTORS, THE 'FAR GATE' IS THE LOCATION WITH THE LONGEST CABLE RUN. THE 'NEAR GATE' CIRCUIT ON THE SURGE PANEL HAS AN ADJUSTABLE RESISTOR IN SERIES WITH L1 AND L2 THAT PROVIDES VOLTAGE ADJUSTMENT.

**CONTACTS CLOSED & FUNCTION**

- (SHOWN WITH GATE UP)
6. 45°- 90° POWER DOWN
  7. 0°-89° POWER UP
  8. 83°- 90° FLASHING LIGHT
  9. 5°- 90° BELL
  10. 0°- 5° HORIZONTAL SNUB

**S-40 GATE COMPONENTS**

- R1 - DOWN SNUB RESISTOR, ADJ.
- R2 - POWER DOWN RATE RESISTOR
- R3 - POWER DOWN LIMIT RESISTOR
- R4 - OSM SNUB RESISTOR
- R5 - DEFROSTER
- K1 - GATE RELAY
- OSM - OVERSPEED MODULE

**Figure 10-8: Typical Two-Gate Application (Common Gate Return) Using 20-Ampere Crossing Controller With Lighting/ Surge Panel A91170-1 (Page 2 of 2)**

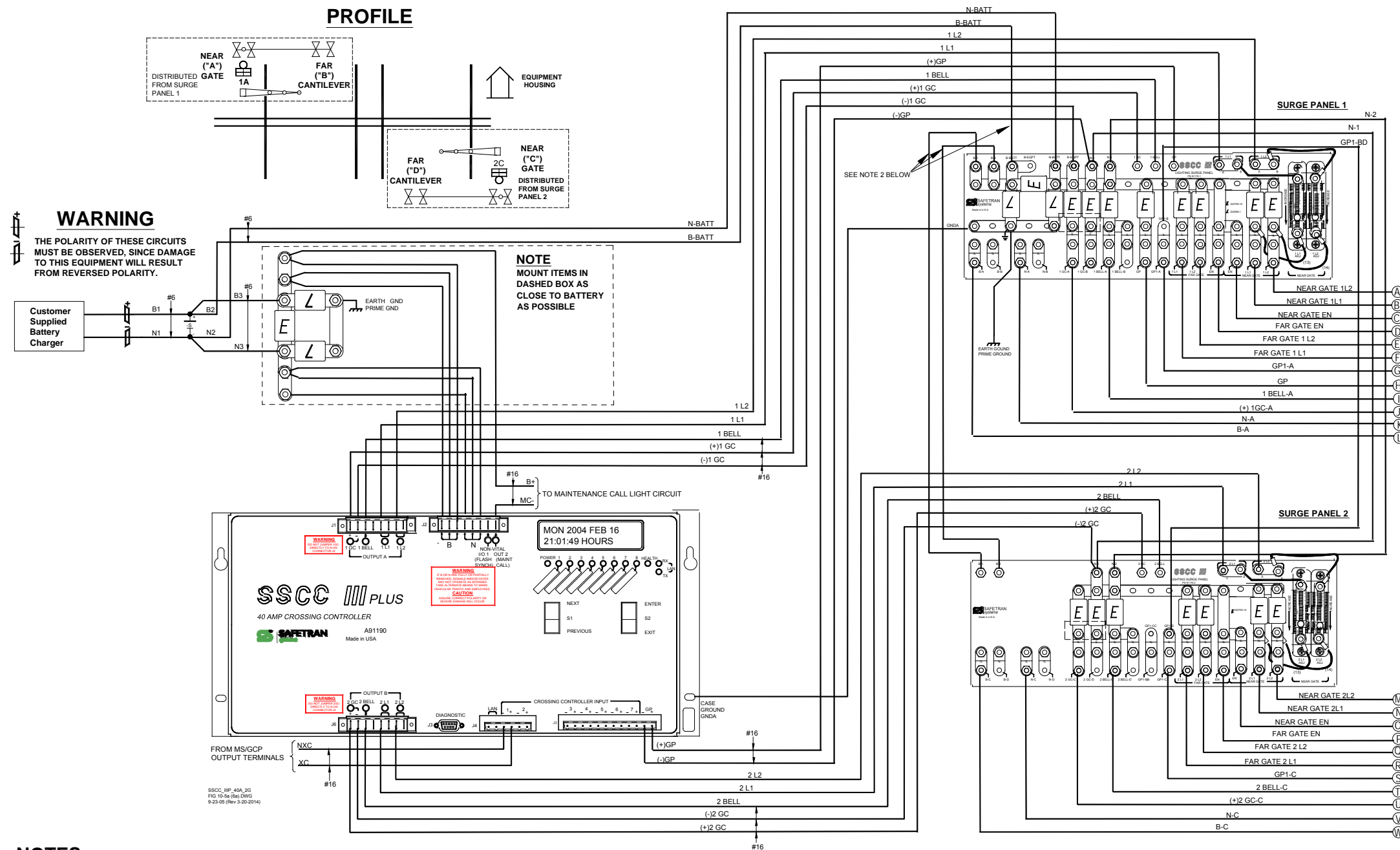

**NOTES**

1. ALL WIRING #10 AWG MINIMUM UNLESS OTHERWISE NOTED. WIRE SIZES SHOWN ARE MINIMUM GAUGE.
2. THESE CONNECTIONS NOT REQUIRED IF GATES ARE NOT USED.
3. THE FOLLOWING SURGE PANEL SYMBOLS ARE USED:  
 E = 022700-1X EQUALIZER  
 L = 022585-1 ARRESTER CLEARVIEW H. D.  
 IL = INSULATED TESTING LINK

**Figure 10-9: Typical Two-Gate Application (Common Gate Return) With Cantilever Flashers, 40-Ampere Crossing Controller With Lighting/Surge Panels A91170-1 and A91170-2 (Page 1 of 2)**



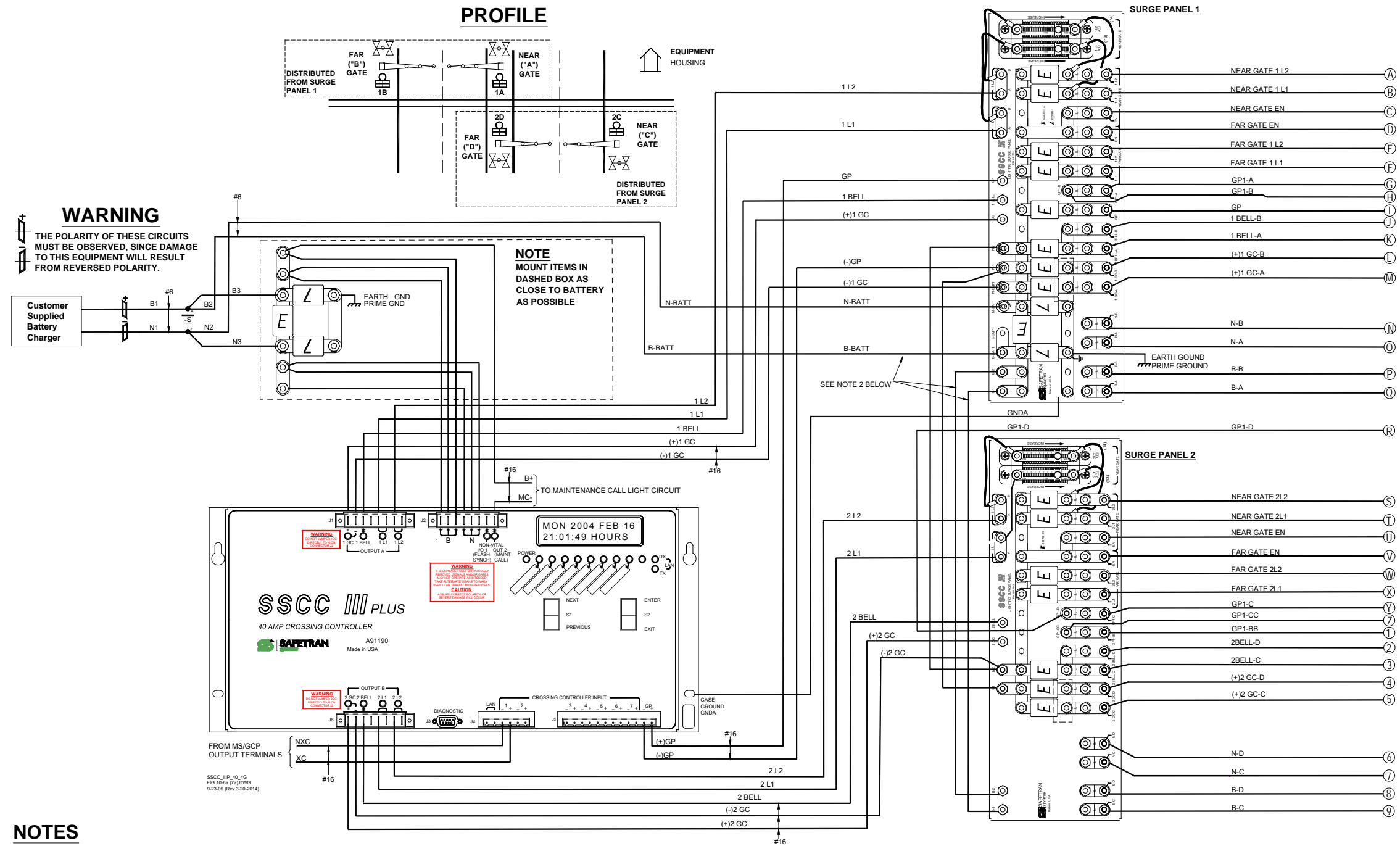

**NOTES**

1. ALL WIRING #10 AWG MINIMUM UNLESS OTHERWISE NOTED. WIRE SIZES SHOWN ARE MINIMUM GAUGE.
2. THESE CONNECTIONS NOT REQUIRED IF GATES ARE NOT USED.
3. THE FOLLOWING SURGE PANEL SYMBOLS ARE USED:  
 E = 022700-1X EQUALIZER  
 L = 022585-1 ARRESTER CLEARVIEW H. D.  
 IL = INSULATED TESTING LINK

**Figure 10-11: Typical Four-Gate Application (Common Gate Return) Using 40- Ampere Crossing Controller With Lighting/Surge Panels A91170-1 and A911 70-2 (Page 1 of 2)**

APPLICATION DRAWINGS

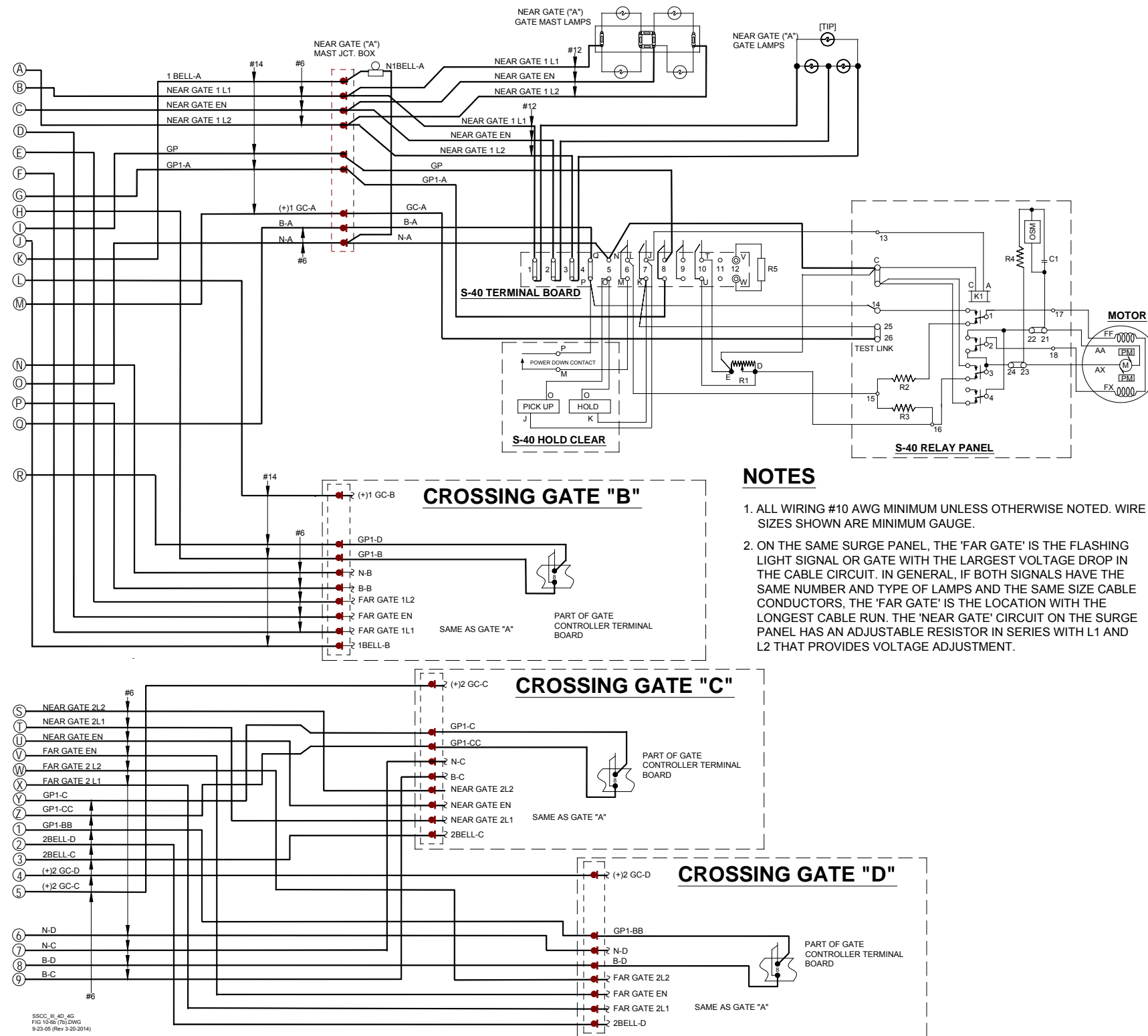

**S-40 GATE COMPONENTS**

- R1 - DOWN SNUB RESISTOR, ADJ.
- R2 - POWER DOWN RATE RESISTOR
- R3 - POWER DOWN LIMIT RESISTOR
- R4 - OSM SNUB RESISTOR
- R5 - DEFROSTER
- K1 - GATE RELAY
- K2 - MAINT. SWITCH RELAY
- OSM - OVERSPEED MODULE

**CONTACTS CLOSED & FUNCTION**

- (SHOWN WITH GATE UP)
- 6. 45° - 90° POWER DOWN
  - 7. 0° - 89° POWER UP
  - 8. 83° - 90° FLASHING LIGHT
  - 9. 5° - 90° BELL
  - 10. 0° - 5° HORIZONTAL SNUB

**NOTES**

1. ALL WIRING #10 AWG MINIMUM UNLESS OTHERWISE NOTED. WIRE SIZES SHOWN ARE MINIMUM GAUGE.
2. ON THE SAME SURGE PANEL, THE 'FAR GATE' IS THE FLASHING LIGHT SIGNAL OR GATE WITH THE LARGEST VOLTAGE DROP IN THE CABLE CIRCUIT. IN GENERAL, IF BOTH SIGNALS HAVE THE SAME NUMBER AND TYPE OF LAMPS AND THE SAME SIZE CABLE CONDUCTORS, THE 'FAR GATE' IS THE LOCATION WITH THE LONGEST CABLE RUN. THE 'NEAR GATE' CIRCUIT ON THE SURGE PANEL HAS AN ADJUSTABLE RESISTOR IN SERIES WITH L1 AND L2 THAT PROVIDES VOLTAGE ADJUSTMENT.

**Figure 10-12: Typical Four-Gate Application (Common Gate Return) Using 40- Ampere Crossing Controller With Lighting/Surge Panels A91170-1 and A911 70-2 (Page 2 of 2)**

This page intentionally left blank



## APPENDIX A

### SSCC III PLUS MCF RELEASE HISTORY



#### CAUTION

THE MCFs LISTED BELOW ARE VALID AS OF THE PUBLICATION DATE ON THIS MANUAL, BUT WILL BE UPDATED AS OPERATIONAL FEATURES ARE ENHANCED OR CHANGED. CONTACT SIEMENS RAIL AUTOMATION CUSTOMER SERVICE FOR THE LATEST MCF REVISIONS. THE PURPOSE OF THIS NOTICE IS TO TRACK THE MCF REVISION HISTORY AND INDICATE THE MOST CURRENT VERSION.

An SSCC III PLUS can be used in many different applications. Each application is contained in a Module Configuration File (MCF).



#### WARNING

TO ENSURE PROPER SSCC III PLUS OPERATION, VERIFY THAT THE CORRECT MCF IS INSTALLED. ALSO VERIFY THAT ALL MENU ITEMS HAVE BEEN CORRECTLY PROGRAMMED.

MCF Part Number	MCF Name	Current MCF Version	MCF CRC	Minimum Release Level
9V610-A001F	basic.mcf	F	1D240612	E
9V610-A002H	basicpls.mcf	H	731AF326	E
9V610-A003E	3trk1wrp.mcf	E	F71FB717	C
9V610-A004E	2trk2wrp.mcf	E	7A946518	C
9V610-A005F	2trkdstk.mcf	F	A9776265	D
9V610-A006E	supisl.mcf	E	2E0E7907	C
9V610-A007E	3trk2trn.mcf	E	054AA764	C
9V610-A008E	2trk2trn.mcf	E	716DF247	C
9V610-A009F	daxprmt.mcf	F	670AE50F	D
	(reserved)	(n/a)		
	(reserved)	(n/a)		

**WARNING**

**WARNING**

**UNLESS DISTRIBUTED AS A GENERAL UPGRADE, AUTHORIZATION FROM SIEMENS RAIL AUTOMATION CORPORATION MUST BE RECEIVED BEFORE ANY MCFs NOT LISTED ABOVE CAN BE INSTALLED.**

**NOTE**

**NOTE**

20-Amp SSCC III PLUS units do not have the capability to execute DAXPRMT MCF.

See the following tables for MCF change history.

**BASIC**

MCF Revision/CRC	PVCS Date	Mandatory Update (Yes/No)	Change History
F/1D240612	2-11-04	No	Changes to keep gate down until input is restored during Bootup/Reboot.
E/8F638122	04-15-03	Yes	Changes to prevent MCFs designed for 40-amp units from running on 20-amp units.
D/48CED749	02-10-03	No	Implemented MCF ID number.
C/4457951A	11-14-02	No	Changed default Flash Rate to "50 FPM" (US standard), changed default Daylight Savings function to "OFF".
B/1AA41911	07-19-02	No	Added Minimum Activation Timer, turn off Maintenance Call light when open neutral wire is detected.
A/90D8165F	03-11-02	No	Initial release.

**BASICPLS**

<b>MCF Revision/CRC</b>	<b>PVCS Date</b>	<b>Mandatory Update (Yes/No)</b>	<b>Change History</b>
H/731AF326	11-15-04	No	Added support for highway advance warning beacons. Extended range of advance pre-empt and minimum activation timers to 99 seconds.
F/72ADEE59	04-01-04	No	Minor performance and logic interlocking improvements. Standardized 2GC behavior for all unhealthy operations.
E/B3B8592E	04-15-03	Yes	Changes to prevent MCFs designed for 40-amp units from running on 20-amp units. Included Advance Pre-Empt Health relay contacts in Advance Pre-Empt Logic equation.
D/7BCFA03B	02-10-03	No	Implemented MCF ID number, and increased Advance Pre-Empt timer range from 30 to 60 seconds.
C/2E8DDC07	11-14-02	No	Changed default Flash Rate to "50 FPM" (US standard), changed default Daylight Savings function to "OFF", changed "GC2/I7" to "2GC/I7".
B/26F6DC0C	09-06-02	No	Changed default value of Minimum Activation Timer to 20sec., disable Out of Service menu if track is not used.
A/D0FC3514	07-23-02	No	Initial release.

**3TRK1WRP**

<b>MCF Revision/CRC</b>	<b>PVCS Date</b>	<b>Mandatory Update (Yes/No)</b>	<b>Change History</b>
E/F71FB717	11-15-04	No	Added support for highway advance warning beacons. Extended range of advance pre-empt and minimum activation timers to 99 seconds.
D/1DA21069	04-01-04	No	Minor performance and logic interlocking improvements. Standardized 2GC behavior for all unhealthy operations.
C/E4237E2F	04-15-03	Yes	Changes to prevent MCFs designed for 40-amp units from running on 20-amp units. Included Advance Pre-Empt Health relay contacts in Advance Pre-Empt Logic equation.
B/3D60F026	02-10-03	No	Implemented MCF ID number, and increased Advance Pre-Empt timer range from 30 to 60 seconds.
A/51114734	10-26-02	No	Initial release.

**2TRK2WRP**

<b>MCF Revision/CRC</b>	<b>PVCS Date</b>	<b>Mandatory Update (Yes/No)</b>	<b>Change History</b>
E/7A946518	11-15-04	No	Added support for highway advance warning beacons. Extended range of advance pre-empt and minimum activation timers to 99 seconds.
D/137F504A	04-01-04	No	Minor performance and logic interlocking improvements. Standardized 2GC behavior for all unhealthy operations.
C/7C4D8659	04-15-03	Yes	Changes to prevent MCFs designed for 40-amp units from running on 20-amp units. Included Advance Pre-Empt Health relay contacts in Advance Pre-Empt Logic equation.
B/42968540	02-10-03	No	Implemented MCF ID number, and increased Advance Pre-Empt timer range from 30 to 60 seconds.
A/6458CD30	10-26-02	No	Initial release.

**2TRKDSTK**

<b>MCF Revision/CRC</b>	<b>PVCS Date</b>	<b>Mandatory Update (Yes/No)</b>	<b>Change History</b>
F/A9776265	11-15-04	No	Added support for highway advance warning beacons. Extended range of advance pre-empt and minimum activation timers to 99 seconds. Extended range of stick release timer to 120 minutes. Additional support for test switch on Input 7. Allows cancellation of advance pre-empt timer on island input when operating in Beacon mode. Added support to disable Island Delay. Changed approach inputs (1, 3, 4, 6) to include 2 seconds slow release delay.
E/C8E74111	04-01-04	No	Minor performance and logic interlocking improvements. Standardized 2GC behavior for all unhealthy operations.
D/86E6FB77	04-15-03	Yes	Changes to prevent MCFs designed for 40-amp units from running on 20-amp units. Included Advance Pre-Empt Health relay contacts in Advance Pre-Empt Logic equation.
C/CAA5C963	02-10-03	No	Implemented MCF ID number, increased Advance Pre-Empt timer range from 30 to 60 seconds, and included Opposite Direction stick relay contacts in stick relay equations.
B/5767CC59	11-14-02	No	Changed default Flash Rate to "50 FPM" (US standard), changed default Daylight Savings function to "OFF", changed "GC2/I7" to "2GC/I7".
A/0B7F0013	09-23-02	No	Initial release.

**SUPISL**

<b>MCF Revision/CRC</b>	<b>PVCS Date</b>	<b>Mandatory Update (Yes/No)</b>	<b>Change History</b>
E/2E0E7907	11-15-04	No	Added support for highway advance warning beacons. Extended range of advance pre-empt and minimum activation timers to 99 seconds.
D/7B52400D	4-01-04	No	Minor performance and logic interlocking improvements. Standardized 2GC behavior for all unhealthy operations.
C/4B2DFA28	04-15-03	Yes	Changes to prevent MCFs designed for 40-amp units from running on 20-amp units. Included Advance Pre-Empt Health relay contacts in Advance Pre-Empt Logic equation.
B/1FD81C11	02-10-03	No	Implemented MCF ID number, and increased Advance Pre-Empt timer range from 30 to 60 seconds.
A/FA956A6C	11-02-02	No	Initial release.

**3TRK2TRN**

<b>MCF Revision/CRC</b>	<b>PVCS Date</b>	<b>Mandatory Update (Yes/No)</b>	<b>Change History</b>
E/054AA764	11-15-04	No	Added support for highway advance warning beacons. Extended range of advance pre-empt and minimum activation timers to 99 seconds.
D/D691CE34	04-01-04	No	Minor performance and logic interlocking improvements. Standardized 2GC behavior for all unhealthy operations.
C/8AD37401	04-15-03	Yes	Changes to prevent MCFs designed for 40-amp units from running on 20-amp units. Included Advance Pre-Empt Health relay contacts in Advance Pre-Empt Logic equation.
B/7F713366	02-10-03	No	Implemented MCF ID number, and increased Advance Pre-Empt timer range from 30 to 60 seconds.
A/69784C5D	11-02-02	No	Initial release.

**2TRK2TRN**

<b>MCF Revision/CRC</b>	<b>PVCS Date</b>	<b>Mandatory Update (Yes/No)</b>	<b>Change History</b>
E/716DF247	11-15-04	No	Added support for highway advance warning beacons. Extended range of advance pre-empt and minimum activation timers to 99 seconds.
D/5E1E7B13	04-01-04	No	Minor performance and logic interlocking improvements. Standardized 2GC behavior for all unhealthy operations.
C/05331932	04-15-03	Yes	Changes to prevent MCFs designed for 40-amp units from running on 20-amp units. Included Advance Pre-Empt Health relay contacts in Advance Pre-Empt Logic equation.
B/6746651B	02-10-03	No	Implemented MCF ID number, and increased Advance Pre-Empt timer range from 30 to 60 seconds.
A/A1AE1931	10-28-02	No	Initial release.

**DAXPRMT**

<b>MCF Revision/CRC</b>	<b>PVCS Date</b>	<b>Mandatory Update (Yes/No)</b>	<b>Change History</b>
F/670AE50F	11-15-04	No	Extended range of advance pre-empt and minimum activation timers to 99 seconds and set these timers up to run sequentially. Corrected problem that caused momentary indication of pre-empt relay fail with each crossing activation.
E/7B0CE142	04-01-04	No	Minor performance and logic interlocking improvements. Standardized 2GC behavior for all unhealthy operations.
D/8F53E816	04-15-03	Yes	Changes to prevent MCFs designed for 40-amp units from running on 20-amp units. Included Advance Pre-Empt Health relay contacts in Advance Pre-Empt Logic equation.
C/3CB67A22	02-10-03	No	Implemented MCF ID number, and increased Advance Pre-Empt timer range from 30 to 60 seconds.
B/E830FF71	11-27-02	No	Prevents this MCF from operating on a 20-Amp SSCC III PLUS unit.
A/71BAD36A	11-12-02	No	Initial release.



# SSCC III Plus HISTORY CARD

## SITE SETUP DATA

Unit Serial No.: _____		Crossing No.: _____		
Date Installed: _____		Installed By: _____		
<u>Crossing Controller</u> <input type="checkbox"/> 40-ampere unit 91190 <input type="checkbox"/> 20-ampere unit 91195		<u>Surge Panels (Isolated Gate Drive)</u> <input type="checkbox"/> Other _____ <input type="checkbox"/> 91181-1 (use with 40-Amp or 20-Amp isolated gate drive) <input type="checkbox"/> 91181-2 (use with 40-Amp isolated gate drive only)		
		<u>Surge Panels (Common Return Gate Drive)</u> <input type="checkbox"/> Other _____ <input type="checkbox"/> 91170-1 (use with 40-Amp or 20-Amp common gate drive) <input type="checkbox"/> 91170-2 (use with 40-Amp common gate drive only)		
PROGRAM	Notes	Initial Setting By: _____ Date: _____	Setting Changed By: _____ Date: _____	Setting Changed By: _____ Date: _____
FLASH RATE:	30-70 flashes/minute Default = 50	_____ flashes/minute	_____ flashes/minute	_____ flashes/minute
GATES USED:	YES/NO    Default = YES	<input type="checkbox"/> YES <input type="checkbox"/> NO	<input type="checkbox"/> YES <input type="checkbox"/> NO	<input type="checkbox"/> YES <input type="checkbox"/> NO
1 GC DELAY:	3-20 sec.,    Default = 4	_____ seconds	_____ seconds	_____ seconds
2 GC DELAY (40A):	3-20 sec.,    Default = 4	_____ seconds	_____ seconds	_____ seconds
GATE RISING BELL:	ON/OFF,    Default = ON	<input type="checkbox"/> ON <input type="checkbox"/> OFF	<input type="checkbox"/> ON <input type="checkbox"/> OFF	<input type="checkbox"/> ON <input type="checkbox"/> OFF
ENABLED INPUTS:	Inputs 1 – 7 only	<input type="checkbox"/> 1 <input type="checkbox"/> 2 <input type="checkbox"/> 3 <input type="checkbox"/> 4 <input type="checkbox"/> 5 <input type="checkbox"/> 6 <input type="checkbox"/> 7	<input type="checkbox"/> 1 <input type="checkbox"/> 2 <input type="checkbox"/> 3 <input type="checkbox"/> 4 <input type="checkbox"/> 5 <input type="checkbox"/> 6 <input type="checkbox"/> 7	<input type="checkbox"/> 1 <input type="checkbox"/> 2 <input type="checkbox"/> 3 <input type="checkbox"/> 4 <input type="checkbox"/> 5 <input type="checkbox"/> 6 <input type="checkbox"/> 7
GC2/I7:	GC2 normal, I7 = normal GC2 inverted, I7 = normal GC2 prmt, I7 = prmt health GC2 Beacon	<input type="checkbox"/> NORMAL <input type="checkbox"/> INVERTED <input type="checkbox"/> PRE-EMPT SIM <input type="checkbox"/> PRE-EMPT ADV <input type="checkbox"/> BEACON	<input type="checkbox"/> NORMAL <input type="checkbox"/> INVERTED <input type="checkbox"/> PRE-EMPT SIM <input type="checkbox"/> PRE-EMPT ADV <input type="checkbox"/> BEACON	<input type="checkbox"/> NORMAL <input type="checkbox"/> INVERTED <input type="checkbox"/> PRE-EMPT SIM <input type="checkbox"/> PRE-EMPT ADV <input type="checkbox"/> BEACON
Input 7	Input, Prmt Hlth, Test Sw.	<input type="checkbox"/> In <input type="checkbox"/> Health <input type="checkbox"/> Test Sw	<input type="checkbox"/> In <input type="checkbox"/> Health <input type="checkbox"/> Test Sw	<input type="checkbox"/> In <input type="checkbox"/> Health <input type="checkbox"/> Test Sw
Test Sw 2TRKDSTK only	Activate, Act & Stk Release	<input type="checkbox"/> Activate <input type="checkbox"/> Act & Rel	<input type="checkbox"/> Activate <input type="checkbox"/> Act & Rel	<input type="checkbox"/> Activate <input type="checkbox"/> Act & Rel
ADV PRE-EMPT TIME (40A):	1 – 99 sec.,    Default = 1	_____ seconds	_____ seconds	_____ seconds
MIN ACTIVATION TIME <sup>1</sup>	0 – 99 sec.,    Default = 20	_____ seconds	_____ seconds	_____ seconds
STICK RELEASE TIME	5–120 min.,    Default =15	_____ minutes	_____ minutes	_____ minutes
BEACON PICKUP DELAY	5-600 sec.,    Default =20	_____ seconds	_____ seconds	_____ seconds
SUP ISLAND TIME	5 – 20 min.,    Default = 20	_____ minutes	_____ minutes	_____ minutes
ENABLED OUTPUTS (40A):	Default = A + B	<input type="checkbox"/> A + B <input type="checkbox"/> A <input type="checkbox"/> B	<input type="checkbox"/> A + B <input type="checkbox"/> A <input type="checkbox"/> B	<input type="checkbox"/> A + B <input type="checkbox"/> A <input type="checkbox"/> B
DAYLIGHT SAVING:	Default = DISABLED	<input type="checkbox"/> Enabled <input type="checkbox"/> Disabled	<input type="checkbox"/> Enabled <input type="checkbox"/> Disabled	<input type="checkbox"/> Enabled <input type="checkbox"/> Disabled
DATE:	-	<input type="checkbox"/> Date Set	<input type="checkbox"/> Date Set	<input type="checkbox"/> Date Set
TIME:	24-hour format	<input type="checkbox"/> Time Set	<input type="checkbox"/> Time Set	<input type="checkbox"/> Time Set
PASSWORD:	Default = DISABLED	<input type="checkbox"/> Enabled <input type="checkbox"/> Disabled	<input type="checkbox"/> Enabled <input type="checkbox"/> Disabled	<input type="checkbox"/> Enabled <input type="checkbox"/> Disabled

**SITE SETUP DATA (continued)**

CONFIGURE				
LOS TIMERS: (MCF-dependent)	0-20 seconds, (Inputs 1 – 7, depending on MCF) Default = 0	1: ___ sec 5: ___ sec 2: ___ sec 6: ___ sec 3: ___ sec 7: ___ sec 4: ___ sec	1: ___ sec 5: ___ sec 2: ___ sec 6: ___ sec 3: ___ sec 7: ___ sec 4: ___ sec	1: ___ sec 5: ___ sec 2: ___ sec 6: ___ sec 3: ___ sec 7: ___ sec 4: ___ sec
MCF:	-	MCF: ID: ___ CRC: _____	MCF: ID: ___ CRC: _____	MCF: ID: ___ CRC: _____
ATCS Address:	Default = 700000000000			
LOW BATTERY:	9.0-15.0 volts, or Disabled Default = DISABLED	<input type="checkbox"/> Disabled <input type="checkbox"/> Enabled _____ volts	<input type="checkbox"/> Disabled <input type="checkbox"/> Enabled _____ volts	<input type="checkbox"/> Disabled <input type="checkbox"/> Enabled _____ volts
AUX I/O:	Default = NONVITAL OUTPUT	<input type="checkbox"/> NV Out <input type="checkbox"/> Fl Sync In <input type="checkbox"/> Flash Sync Out	<input type="checkbox"/> NV Out <input type="checkbox"/> Fl Sync In <input type="checkbox"/> Flash Sync Out	<input type="checkbox"/> NV Out <input type="checkbox"/> Fl Sync In <input type="checkbox"/> Flash Sync Out
DETECT LAMP NEUTRAL WIRE:	Default = Yes	<input type="checkbox"/> Yes <input type="checkbox"/> No	<input type="checkbox"/> Yes <input type="checkbox"/> No	<input type="checkbox"/> Yes <input type="checkbox"/> No

TEST CONFIGURE				
LAMP TEST CANCEL TIMER:	1-15 minutes, Default = 5	_____ minutes	_____ minutes	_____ minutes
LAMP TEST DELAY TIMER:	30-120 sec, Default = 30	_____ seconds	_____ seconds	_____ seconds
LAMP TEST ON TIMER:	15-60 sec, Default = 15	_____ seconds	_____ seconds	_____ seconds

**STANDARD SETUP LAMP VOLTAGES PROCEDURE  
USING TRUE RMS AC + DC METER, OR CONVERSION TABLE BELOW**

SETUP LAMP VOLTAGES	Initial Setting By: _____ Date: _____ Meter: _____	Initial Setting By: _____ Date: _____ Meter: _____	Initial Setting By: _____ Date: _____ Meter: _____
FAR GATE	1 L1 = _____ volts 1 L2 = _____ volts 2 L1 = _____ volts 2 L2 = _____ volts	1 L1 = _____ volts 1 L2 = _____ volts 2 L1 = _____ volts 2 L2 = _____ volts	1 L1 = _____ volts 1 L2 = _____ volts 2 L1 = _____ volts 2 L2 = _____ volts
SSCC III PLUS	1 L1 = _____ volts 1 L2 = _____ volts 2 L1 = _____ volts 2 L2 = _____ volts	1 L1 = _____ volts 1 L2 = _____ volts 2 L1 = _____ volts 2 L2 = _____ volts	1 L1 = _____ volts 1 L2 = _____ volts 2 L1 = _____ volts 2 L2 = _____ volts
NEAR GATE	1 L1 = _____ volts 1 L2 = _____ volts 2 L1 = _____ volts 2 L2 = _____ volts	1 L1 = _____ volts 1 L2 = _____ volts 2 L1 = _____ volts 2 L2 = _____ volts	1 L1 = _____ volts 1 L2 = _____ volts 2 L1 = _____ volts 2 L2 = _____ volts

**Multimeter Reading Variance From Actual Lamp Voltage**

Battery Voltage	Regulated Lamp Drive Voltage Range	Measurement Below Actual Drive Voltage	
		Using Digital Multimeter (Fluke 87 or Equivalent)	Using Analog Multimeter (TS111)
13.3	9.0 to 12.0	1.3 volts	0.6 volt
	>12.0	0.91 volt	0.42 volt
14.7	9.0 to 12.0	2.2 volts	1.1 volts
	>12.0	1.54 volts	0.77 volts
15.8	9.0 to 12.0	2.6 volts	2.0 volts
	>12.0	1.82 volts	1.4 volts