

SIEMENS

P1 Panelboard Replacement Parts Kit P1CONACPHAL & P1CONACPHCU A/C-Phase Connector Kits (for use in Revised P1 Panelboards ONLY)¹

**Installation
Instructions**

These instructions do not purport to cover all details or variations in equipment, or to provide for every possible contingency to be met in connection with installation, operation or maintenance. Should further information be desired or should particular problems arise, which are not covered sufficiently for the purchaser's purposes, the matter should be referred to the local Siemens sales office. The contents of this Instruction manual shall not become part of or modify any prior or existing agreement, commitment or relationship. The sales contract contains the entire obligation of Siemens. The warranty contained in the contract between the parties is the sole warranty of Siemens. Any statements contained herein do not create new warranties or modify the existing warranty.

Trademarks - Unless otherwise noted, all names identified by ® are registered trademarks of Siemens AG or Siemens Industry, Inc. The remaining trademarks in this publication may be trademarks whose use by third parties for their own purposes could violate the rights of the owner.

¹ To confirm, note the part number of the panel (marked on the interior label).
If it ends in an "N" or a "T" it is a "Revised P1" and is compatible with this kit.
(For example: P1E42MC250A is an Original P1; P1E42MC250AT is a Revised P1)

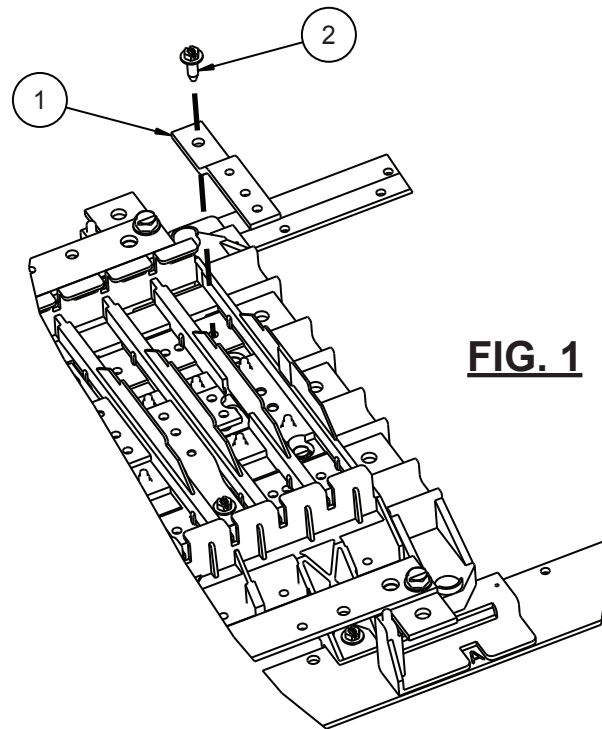

FIG. 1

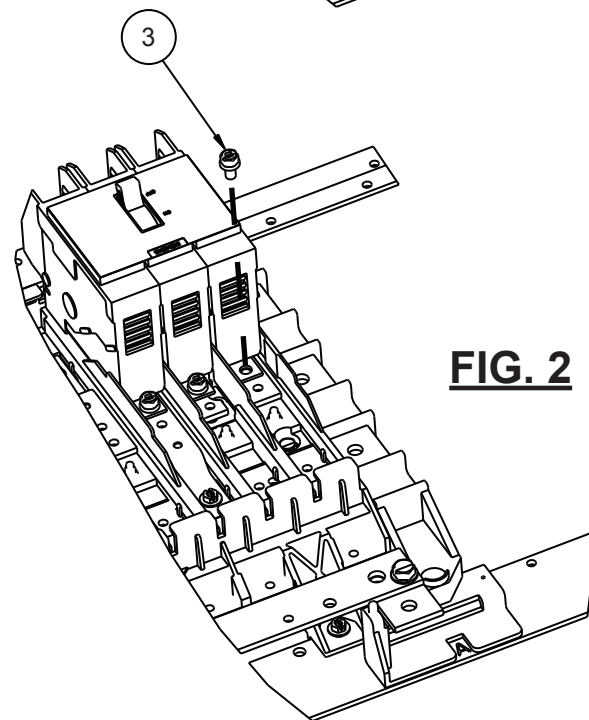

FIG. 2

THIS KIT CONTAINS THE FOLLOWING ITEMS:

ITEM	DESCRIPTION	QTY	TORQUE
1	A/C-PHASE CONNECTOR	6	N/A
2	#10-24 x 9/16" HEX WASHER HEAD SCREW	6	**
3	#10-32 x 5/16" HEX HEAD SEMS* ASSEMBLY SCREW	12	20 lb-in

* SEMS assembly screws have a captive washer on the screw
 ** See torque table on next page

Installation Instructions

The following instructions are for the installation of Siemens replacement part connector kits in a Revised P1 panelboard. The parts provided in this kit are for connection to a 1-phase 2 or 3-wire system or a 3-phase 3 or 4-wire system for BL / BQD / GB Type breakers.



1. **Lock off all power supplying this equipment before working on it.**
2. Remove the deadfront.
3. Remove any/all A-phase & C-phase connectors that are being replaced by the new parts in this kit. (Breakers will need to be removed for access to connectors, if installed.)
4. These connectors are specifically for the A-phase & C-phase connections. For each proper position, attach the phase connector (item 1) to the phase bus using #10-24 hex washer head screws (item 2) as shown in Fig. 1.
5. If the system is 3-phase, B-phase connectors must be installed prior to any breaker installation on the following step. (B-phase connectors available in a separate kit.)
6. Once all necessary connectors are installed, install proper breaker (for system; not provided), using #10-32 SEMS assembly screws (item 3) as shown in Fig. 2.
7. Torque all connections to the values specified on the Hardware Tightening Torque label affixed to the rear of the deadfront.
8. Attach the main cables to the breaker and torque connections to values specified on the device. If no values are listed on the device, refer to the Hardware Tightening Torque label affixed to the rear of the deadfront.
9. **Before energizing the panel, ensure that all connections have been properly torqued, that the deadfront is installed and that all fillers are in place.**

Thread Size	Torque (lb-in) per Bus Material			
	1/8" CU	3/16" AL	3/16" CU	1/4" AL
#10-24	25	30	50	30