



APPLICATION GUIDELINES

MICROPROCESSOR BASED MODEL 3000 GRADE CROSSING PREDICTOR FAMILY

APRIL 2009, REVISED SEPTEMBER 2014

DOCUMENT NO. S-00-93-01
VERSION D2

Siemens Industry, Inc., Rail Automation
9568 Archibald Ave., Suite 100,
Rancho Cucamonga, California 91730
1-800-793-SAFE

Copyright © 1993 - 2014 Siemens Industry, Inc., Rail Automation
All rights reserved

PROPRIETARY INFORMATION

Siemens Industry, Inc., Rail Automation (Siemens) has a proprietary interest in the information contained herein and, in some instances, has patent rights in the systems and components described. It is requested that you distribute this information only to those responsible people within your organization who have an official interest.

This document, or the information disclosed herein, shall not be reproduced or transferred to other documents or used or disclosed for manufacturing or for any other purpose except as specifically authorized in writing by **Siemens**.

TRANSLATIONS

The manuals and product information of Siemens are intended to be produced and read in English. Any translation of the manuals and product information are unofficial and can be imprecise and inaccurate in whole or in part. Siemens does not warrant the accuracy, reliability, or timeliness of any information contained in any translation of manual or product information from its original official released version in English and shall not be liable for any losses caused by such reliance on the accuracy, reliability, or timeliness of such information. Any person or entity who relies on translated information does so at his or her own risk.

WARRANTY INFORMATION

Siemens Industry, Inc., Rail Automation warranty policy is as stated in the current Terms and Conditions of Sale document. Warranty adjustments will not be allowed for products or components which have been subjected to abuse, alteration, improper handling or installation, or which have not been operated in accordance with Seller's instructions. Alteration or removal of any serial number or identification mark voids the warranty.

SALES AND SERVICE LOCATIONS

Technical assistance and sales information on **Siemens Industry, Inc., Rail Automation** products may be obtained at the following locations:

Siemens Industry, Inc., Rail Automation
2400 NELSON MILLER PARKWAY
LOUISVILLE, KENTUCKY 40223
TELEPHONE: (502) 618-8800
FAX: (502) 618-8810
SALES & SERVICE: (800) 626-2710
WEB SITE: <http://www.rail-automation.com/>

Siemens Industry, Inc., Rail Automation
939 S. MAIN STREET
MARION, KENTUCKY 42064
TELEPHONE: (270) 918-7800
CUSTOMER SERVICE: (800) 626-2710
TECHNICAL SUPPORT: (800) 793-7233
FAX: (270) 918-7830

FCC RULES COMPLIANCE

The equipment covered in this manual has been tested and found to comply with the limits for a Class A digital device, pursuant to part 15 of the FCC Rules. These limits are designed to provide reasonable protection against harmful interference when the equipment is operated in a commercial environment. This equipment generates, uses, and can radiate radio frequency energy and, if not installed and used in accordance with the instruction manual, may cause harmful interference to radio communications. Operation of this equipment in a residential area is likely to cause harmful interference in which case the user will be required to correct the interference at his/her own expense.

DOCUMENT HISTORY

Version	Release Date	Details of Change
A	March 1993	Initial Release
B	April 1999	unknown
C		<p>Paragraph 1.1 “System Specifications”</p> <ul style="list-style-type: none"> • Added 80211 IPI and additional frequencies <p>Section II</p> <ul style="list-style-type: none"> • Added text to paragraph (3) Rusty Rail <p>Paragraph 3.5</p> <ul style="list-style-type: none"> • Added NOTE: “At insulated joints ...” <p>Paragraph 4.0</p> <ul style="list-style-type: none"> • Added 80211 to the 8011-f Island Module <p>Paragraph 4.1</p> <ul style="list-style-type: none"> • Added 80211 information <p>Paragraph 5.0</p> <ul style="list-style-type: none"> • Deleted “Safetran” from “(1) Safetran Bond Strand” <p>Paragraph 5.2</p> <ul style="list-style-type: none"> • Added NOTE: “At insulated joints ...” <p>Paragraph 6.5</p> <ul style="list-style-type: none"> • Changed paragraph text into WARNING. <p>Paragraph 7.3</p> <ul style="list-style-type: none"> • Added NOTE: “Combine Transmit (XMT) and check wires ...” <p>Paragraph 8.2</p> <ul style="list-style-type: none"> • Removed reference to Safetran S-Code and replaced it with GEO. Added “..., track devices, and GEO Track Noise Suppression Filter A53252. The GEO...” at end of paragraph. <p>Paragraph 8.4</p> <ul style="list-style-type: none"> • Changed NOTE text to “Typical applications ...” <p>Paragraph 9.0 “General”</p> <ul style="list-style-type: none"> • Added WARNING at the end of the paragraph. <p>Paragraph 9.1 “Relay Adapter Module”</p> <ul style="list-style-type: none"> • Added Relay Adapter Module, A80170 information and installation paragraph, per Safetran Bulletin CSB 1-05, and photograph of the A80170. Re-numbered subsequent paragraphs in Section 9. <p>Paragraph 9.2</p> <ul style="list-style-type: none"> • Added “4000 GCP” to WARNING text and added Note: “At insulated joints ...” <p>Paragraph 10.3</p> <ul style="list-style-type: none"> • Added “Radio DAXing ...” text to end of paragraph (2). <p>Paragraph 10.4.4</p> <ul style="list-style-type: none"> • Changed “E-level (8V980-A01E)” to “F-level (8V980-A01F)” in NOTE. <p>Paragraph 10.4.6</p> <ul style="list-style-type: none"> • Changed “E-level (8V980-A01E)” to “F-level (8V980-A01F)” in NOTE. • Deleted “and can even be set for 0 (zero)” from NOTE. <p>Paragraph 10.6.16</p> <ul style="list-style-type: none"> • Added NOTE: “For GCP3000 systems equipped with 80214 processors ...” <p>Paragraph 12.5</p> <ul style="list-style-type: none"> • Changed “The shunt should not be used ...” text into WARNING. <p>Paragraph 12.6</p> <ul style="list-style-type: none"> • Changed “This multifrequency shunt should not be used ...” text into WARNING.

		<ul style="list-style-type: none"> • Changed NOTE: “The shunt is shipped ...” into CAUTION. • Changed WARNING: “Carefully tighten all nuts ...” into CAUTION. <p>Paragraph 12.8</p> <ul style="list-style-type: none"> • Changed NOTE: “The multifrequency narrow-band shunt is shipped ...” into CAUTION. • Changed WARNING: “Carefully tighten all nuts ...” into CAUTION. <p>Paragraph 12.9</p> <ul style="list-style-type: none"> • Deleted “hermetically” from “The wideband shunt is housed in a hermetically-sealed ...” <p>Paragraph 12.12.1</p> <ul style="list-style-type: none"> • Changed “In applications where the choke is located ...” text into WARNING. <p>Paragraph 12.12.2</p> <ul style="list-style-type: none"> • Removed reference to Safetran S-Code and replaced it with GEO. Added “..., track devices, and GEO Track Noise Suppression Filter A53252. The GEO...” at end of paragraph. <p>Paragraph 12.13</p> <ul style="list-style-type: none"> • Deleted “However, the coupler can be used to bypass insulated joints ...” text. • Inserted “As a general rule, a maximum of two sets of insulated joints ...” text. • Inserted “Minimum Distance to Insulated Joints ...” table. • Deleted WARNING: “This coupler cannot be used ...” • Deleted “hermetically” from “The coupler is housed in a hermetically-sealed ...” • Added NOTE: “Some applications will require tuning ...” <p>Paragraph 12.14</p> <ul style="list-style-type: none"> • Added “80115” to text: “... data recorder module (80015/80115)” • Added NOTE: “The recorded speed information is intended solely as a maintenance tool...” <p>Paragraph 12.15</p> <ul style="list-style-type: none"> • Deleted “Extender Module, 80021” paragraph. <p>Paragraph 12.17</p> <ul style="list-style-type: none"> • Deleted “Sentry Data Recorder Panel Assembly, 91041” paragraph. <p>Section 13</p> <ul style="list-style-type: none"> • Replaced entire section with Section 5 text of Document No. SIG-00-00-02, Ver. B.1, “Instructions & Installation for the Microprocessor Based Grade Crossing Predictor Model 3000 Family.” <p>Section 15.0</p> <ul style="list-style-type: none"> • Added text: “(4) Low resistance connection to earth ground.” <p>Figure 14-6</p> <ul style="list-style-type: none"> • Added A80170 Relay Adapter Module to pins 9 and 10 of 3000 GCP terminal output board. <p>Figure 14-9</p> <ul style="list-style-type: none"> • Added A80170 Relay Adapter Module to pins 9 and 10 of 3000 GCP terminal output board. <p>Figure 14-16</p> <ul style="list-style-type: none"> • Added A80170 Relay Adapter Module to pins 9 and 10 of 3000 GCP terminal output board. <p>Figure 14-17</p> <ul style="list-style-type: none"> • Added A80170 Relay Adapter Module to pins 9 and 10 of 3000 GCP terminal output board.
--	--	--

D

April
2009

SECTION 9:
Page 9-1 Inserted: par. 9.1.1 RELAY ADAPTER MODULE, A80170

Relay Adapter Module (Safetran P/N 8000-80170-001) (see Figure 9-1) must be installed in all existing and future applications where a 3000 MS will be used to directly drive (no relay isolation) any UAX, ISL RLY, MS/GCP CONTROL and/or ENA input on one 3000 GCP and/or 2000 MS unit by the GCP RLY (3000 GCP) and/or MS RLY (2000 MS) output of another unit. The Relay Adapter Module A80170 is installed externally to the 3000 GCP unit and can be wired into the system as shown in Figure 14-9.

NOTE

The Relay Adapter Module is not required where vital relays are used as an interface between the UAX, ISL RLY, MS/GCP CONTROL and/or ENA inputs of one unit and the GCP RLY (3000GCP) or MS RLY (2000MS) output of another unit.

Perform the following steps to install the Relay Adapter Module on a 3000 GCP Unit:

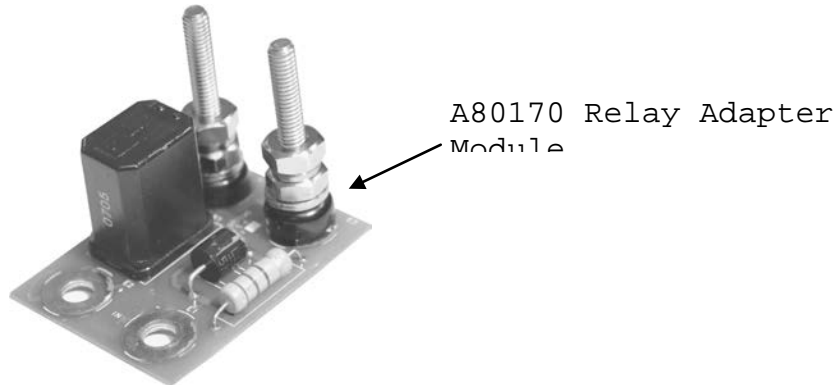


Figure 9-1:
A80170 Relay Adapter Module

1. Remove all wires from Terminal Block (TB) 1-9 on the front panel, including any event recorder wires (TB 1-9 = GCP RLY (+)).
2. Connect all wires removed in step 1 to the OUT (+) terminal on the A80170 Relay Adapter Module.
3. Remove all wires from terminal 10 on the front panel, including any event recorder wires (TB 1-10 = GCP RLY (-)).
4. Connect all wires removed in step 3 to the OUT (-) terminal on the A80170 Relay Adapter Module.
5. Slide the mounting holes at the base of the A80170 Module onto terminals 9 and 10 of the 3000 GCP unit. Fasten the A80170 Module securely using appropriate AREMA-compliant hardware.
6. When installation of the A80170 module is complete, test UAX, ISL RLY, MC/GCP CONTROL and/or ENA circuits per railroad policies and procedures.

SECTION 10:

NOTE

When a GCP is operating in a back to back application as shown in Figure 10-12, proper canceling of the loss-of-shunt timer and proper recording of warning time requires that the Island Relay 1 and Island Relay 2 (+) and (-) terminals must be strapped together as depicted in Figure 10-13.

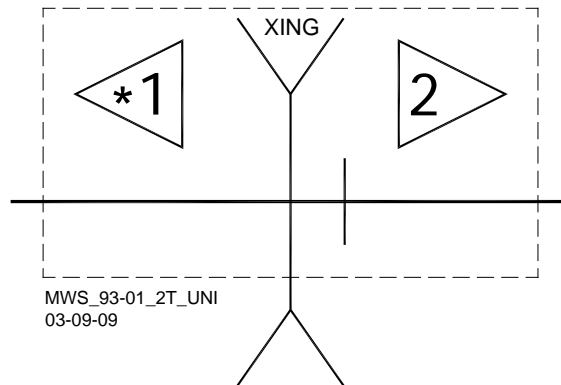


Figure 10-12
Back-to-Back Model 3000 GCP Application

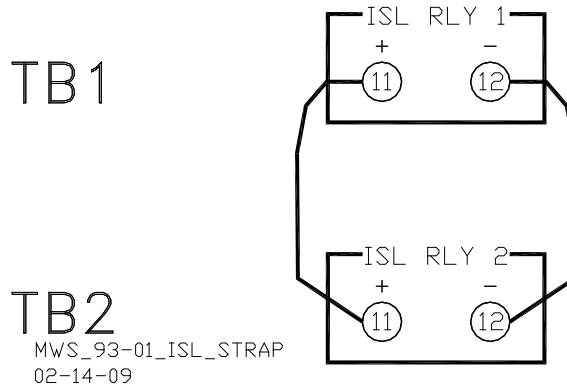


Figure 10-13:
Island Relay Strapping in Back-to-Back Application

Since only a single island module is used in the GCP (TI), strapping the island terminals together supplies GCP logic information which enables proper recording of warning time and proper canceling of the time remaining in the T2 loss-of-shunt pickup delay timer.

When two GCPs are operating in a back to back application on double track as shown in Figure 10-14, proper canceling of the loss-of-shunt timers and proper recording of warning times requires that the Island Relay 1 of GCP1 and Island Relay 1 of GCP 2 (+) and (-) terminals must be strapped together. In addition, Island Relay 2 of GCP1 and Island Relay 2

of GCP 2 (+) and (-) terminals must be strapped together as depicted in Figure 10-15.

Strapping the appropriate island terminals together supplies the GCP with logic information which enables proper recording of warning time and proper canceling of the time remaining in the T2 loss-of-shunt pickup delay timers for GCP 2.

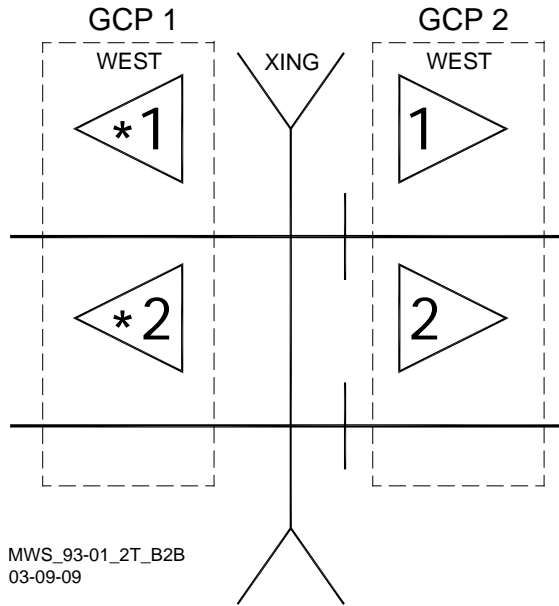


Figure 10-14:
Two GCPs in Back-to-Back Application on Double Track

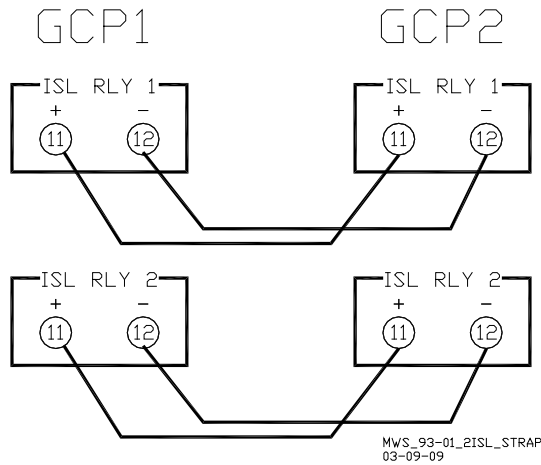


Figure 10-15:
Strapping Island Relays on Two GCPs in
Back-to-Back Application on Double Track

10.9 Common UAX Application Guidelines

WARNING

WHEN THE UAX1 FEATURE IS PROGRAMMED TO OFF (ZERO TIME ENTERED), THE UAX TERMINALS (UAX 1) AT TB2-7 & TB2-8 ON THE MODEL 3000 GCP FRONT PANEL HAVE NO CONTROL OVER THE MS/GCP RELAY DRIVE OUTPUT. WHEN THE UAX1 FEATURE IS PROGRAMMED BETWEEN 1 AND 500 AND A NOMINAL 12 VOLTS IS REMOVED FROM THE UAX TERMINALS, THE MS/GCP RELAY OUTPUT IS IMMEDIATELY DEENERGIZED. WHEN 12 VOLTS IS REAPPLIED TO THE UAX TERMINALS, THE MS/GCP RELAY DRIVE ENERGIZES AFTER THE UAX1 PICKUP DELAY TIME HAS ELAPSED (PROVIDING NO OTHER CONDITION KEEPS THE MS/GCP RELAY DRIVE DEENERGIZED).

WHEN THE ENA/UAX2 FEATURE IS NOT USED, UNLIKE UAX1, THE ENA TERMINAL TB1-5 MUST BE STRAPPED TO BATTERY B AT TERMINAL TB1-6 ON THE 3000 FRONT PANEL AND THUS WILL HAVE NO CONTROL OVER THE MS/GCP RELAY DRIVE OUTPUT. WHEN THE UAX2 FEATURE IS PROGRAMMED BETWEEN 1 AND 500 AND A NOMINAL 12 VOLTS IS REMOVED FROM THE ENA (UAX2) TERMINAL, THE MS/GCP RELAY OUTPUT IS IMMEDIATELY DEENERGIZED. WHEN 12 VOLTS IS REAPPLIED TO THE UAX2 TERMINAL, THE MS/GCP RELAY DRIVE ENERGIZES AFTER THE UAX2 PICKUP DELAY TIME HAS ELAPSED (PROVIDING NO OTHER CONDITION KEEPS THE MS/GCP RELAY DRIVE DEENERGIZED).

10.9.1 Turning off the UAX1 and ENA/UAX2 functions

CAUTION

READ THE FOLLOWING APPLICATION INFORMATION CAREFULLY IN 10.9.1, 10.9.2, AND 10.9.3 TO ENSURE APPLICATION PROGRAMING COMPLIANCE PRIOR TO PLACING THIS EQUIPMENT IN SERVICE.

When the UAX 1 input is not used, program UAX 1 to zero (0) time. This deactivates the function, which permits recovery of the MS/GCP Relay Drive. No external Battery connections are required on the UAX front panel terminals when programmed to zero.

When the ENA/UAX 2 input is not used, the ENA terminal must be strapped to battery B by connecting the ENA/UAX2 terminal (TB1-5) to the B terminal (TB1-6), which deactivates the function and permits recovery of the MS/GCP Relay Drive.

10.9.2 UAX1 and ENA/UAX2 input control of T1 and T2

The UAX terminals on the front panel are used for external control of the track 1 section of the 3000 GCP and only the track 1 island circuit, upon pickup, will cancel any UAX 1 time remaining as the train leaves the island circuit. The UAX1 pickup time is a programmable entry.

The ENA/UAX 2 terminal provides a UAX2 input to the track 2 section of the GCP. When the UAX2/ENA function is programmed for zero (0) seconds of pickup delay, the function changes from a UAX2 into an ENABLE input. The enable input controls both Track 1 and Track 2 sections of the GCP and has no pickup delay when the ENA is energized. When the ENA/UAX2 is programmed for a pickup delay other than 0, it changes to a UAX2 function and controls only the track 2 section of the 3000 GCP. Only the track 2 island (upon energizing) will cancel any UAX 2 time remaining when a train leaves its associated island circuit.

10.9.3 Rules Regarding De-energizing Relay Drive Outputs Using Inputs UAX1, UAX2 and ENA.

There are up to five relay drive outputs available in the GCP 3000: GCP, DAX A, DAX B, DAX C and DAX D. The rules governing de-energizing of relay drive outputs are as follows:

1. GCP Relay: This output is a combination of T1 and T2 prime predictors. When de-energized, either or both predictors will cause the GCP output to de-energize. The GCP output will also de-energize whenever the UAX1, ENABLE or UAX2 is deenergized. The GCP Relay will drop out if the prime prediction offset is used.

NOTE:

The UAX1, UAX2 and ENA functions will de-energize only certain DAX relay drive outputs depending on the programmed DAX offset distance and which track (T1 or T2) the DAXes are assigned.

2. DAX A, DAX B, DAX C, or DAX D Relays: When any DAX is used and is programmed with an offset distance greater than zero, it will NOT de-energize when UAX1, ENABLE or UAX2 deenergizes.
3. DAX A, DAX B, DAX C, or DAX D Relays: When a DAX is programmed with a zero (0) offset distance (Preempt) and is assigned to T1, then only UAX1 or ENABLE when deenergized will de-energize that DAX (preempt) output. When a DAX is programmed with a zero (0) offset distance (Preempt) and is assigned to T2, then only UAX2 or ENABLE when deenergized will de-energize that DAX (preempt) output.

10.9.4 Single Track UAX and ENA Applications

The following three single track/DAX applications (paragraphs 10.9.4.1, 10.9.4.2, and 10.9.4.3) provide a review of the basic UAX/ENA/DAX pickup delay programming requirements.

10.9.4.1 Single Track Using Separate GCPs with Active UAX Controlled from a Remote Location

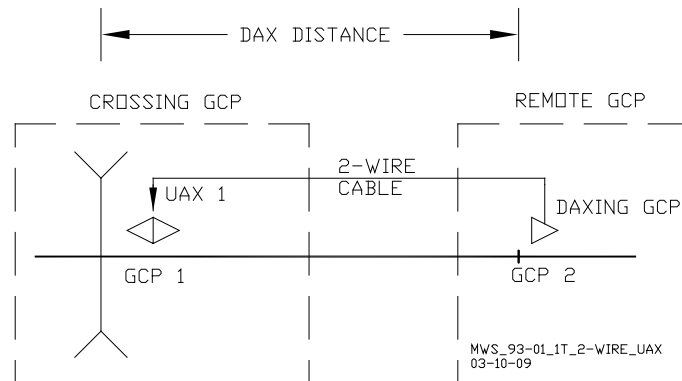


Figure 10-20:
DAX Programming Requirements
(Single Track, Dual GCP, UAX Controlled From Remote Location)

1. Program UAX 1 (GCP 1) for 25 seconds.
2. Connect GCP battery B to ENA/UAX 2 Terminal.
3. Program the DAX pickup delay time at the remote location (GCP 2) for 15 seconds, or to the value presently programmed if longer.
4. If prime prediction offset is used at the remote DAX (GCP 2), program the remote prime pickup delay time for 15 seconds or to the value presently programmed if longer.

10.9.4.2 Single Track Using Separate GCPs with Active ENA Controlled from a Remote Location

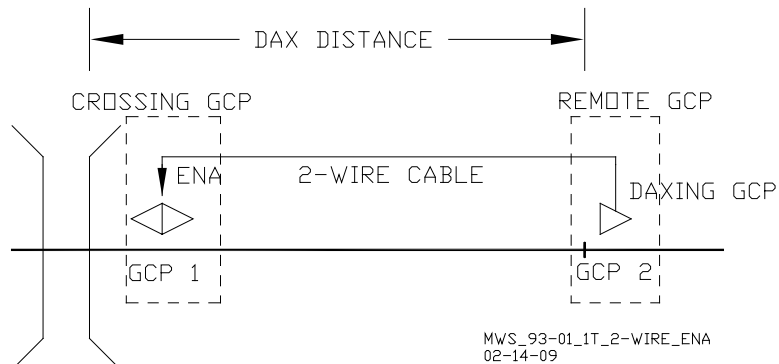


Figure 10-21:
DAX Programming Requirements
(Single Track, Dual GCP, ENA Controlled From Remote Location)

WARNING

IF THE REMOTE DAX (GCP 2) IS OTHER THAN A 3000/4000 GCP (A MODEL 660, 400, HXP, ETC.), THE ENABLE INPUT CANNOT BE USED. THE UAX INPUT AND ITS ASSOCIATED PROGRAMING MUST BE USED AS ILLUSTRATED AND DISCUSSED IN PARAGRAPH 10.9.4 ABOVE.

NOTE

Some applications use the ENA (Enable) input instead of the UAX input for crossing control from a remote 3000 GCP DAX. When programming the 3000 GCP to utilize the ENA functionality, the pickup delay is set to zero (0); therefore all required pickup delay time must be provided by the DAX pickup delay (either Model 3000 or 4000 GCP).

The actual DAX pickup delay for through-move trains, when in AUTO mode, is automatically computed to recover shortly after a train arrives at the street.

1. Program ENA/UAX2 (GCP 1) for zero (0) time (to activate the Enable function).
2. Since the UAX input is not used (no wires connected to the UAX terminals), program UAX 1 for 0 (zero) time.
3. Program the DAX pickup delay time at the remote location (GCP 2) for 15 seconds, or to the value presently programmed if longer.
4. If prime prediction offset is used at the remote DAX (GCP 2), program the remote prime pickup delay time for 15 seconds or to the value presently programmed if longer.

10.9.4.3 Single Track using Single GCP (No UAX or Enable Used)

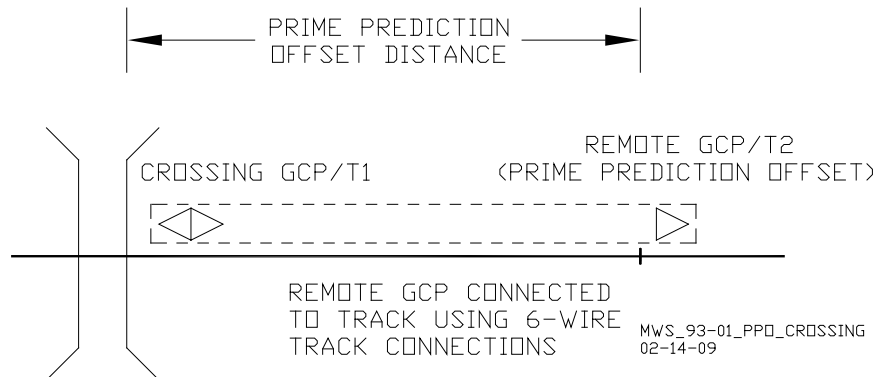


Figure 10-22:
DAX Programming Requirements
(Single Track, Crossing and Remote GCPs (T1 and T2) in Same GCP Case)

1. Since the UAX is not required, program UAX 1 for zero (0) time (off).
2. Connect GCP Battery B to ENA/UAX 2 terminal.
3. Program the prime pickup delay time of T2 in the Function menu for 15 seconds or to the value presently programmed if longer.

10.9.5 Double Track UAX/ENA Applications

In double track applications with remote DAX control, important differences exist when programming the UAX/ENA/DAX pickup delays. These programming differences must be carefully reviewed before placing the crossing in operation. The programming differences are necessary to allow for:

- Proper canceling of any remaining pickup delay time in UAX 1 or UAX 2 timers as a fast-moving, short train leaves the island circuit
- Accurate recording of crossing warning times in History and the data recorder when the crossing is started from remote DAX's.

The double track/DAX application figures provided in paragraphs 10.9.5.1 (see Figure 10-23 and Figure 10-24), 10.9.5.2 (see Figure 10-25), and 10.9.5.3 (see Figure 10-26 and Figure 10-27) that follow provide the UAX/ENA/DAX pickup delay requirements.

10.9.5.1 Double Track Installations with Active UAX from a Remote DAX location

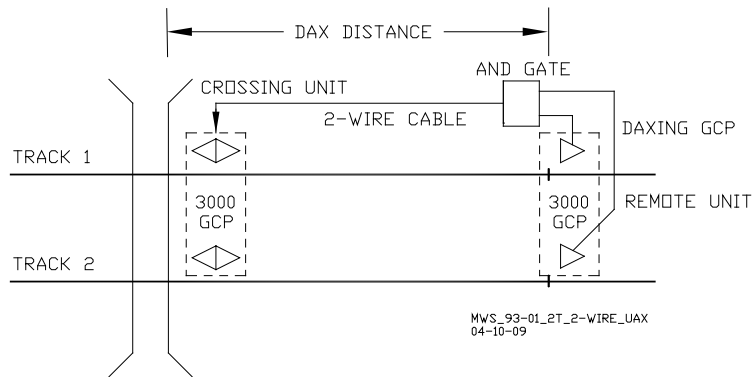


Figure 10-23:
DAX Programming Requirements
(Double Track, Dual GCPs, Active UAX From a Remote DAX Location Via AND Gate)

WARNING

IF THE REMOTE DAXING GCP'S ARE OTHER THAN 3000/4000 GCP'S (MODEL 660, 400, HXP, ETC.), THIS APPLICATION CANNOT BE USED. INDEPENDENT UAX CONTROLS AND THEIR PROGRAMING APPLICATION MUST BE USED AS ILLUSTRATED AND DISCUSSED IN PARAGRAPH 10.9.5.

IF THE ENA (ENABLE) TERMINAL IS ALREADY WIRED FOR DAXES FROM ANOTHER REMOTE GCP OR OTHER CROSSING CONTROL CIRCUIT, ENA WIRING MUST BE APPLIED DIFFERENTLY. CONTACT SAFETRAN APPLICATION ENGINEERING FOR SPECIFIC INSTRUCTIONS.

NOTE

The actual DAX pickup delay for through-move trains is automatically computed to recover shortly after a train arrives at the street.

To accurately record crossing warning times when a

GCP is operating as shown in Figure 10-23, the UAX 1 and ENA/UAX 2 terminals must be strapped together as shown in Figure 10-24 and both functions are programmed to 1 second.

1. Program UAX 1 in GCP 1 for one (1) second.
2. Set each DAX pickup delay time (T1DAX A and T2DAX B) at the remote DAX location for 15 seconds, or to the value presently programmed if longer. If prime prediction offset is used instead of the DAXes at the remote location, program each remote prime pickup delay for 15 seconds or to the value presently programmed if longer. In addition, if prime predictors are used at the remote (prime prediction offset) then the AND gate is not required and use the GCP output terminals (Note: T1 prime and T2 prime are already internally ANDed).
3. Strap UAX 1 and ENA/UAX 2 in parallel as shown in 10-24.
4. Program ENA/UAX2 for one (1) second. Ensure ENA terminal is not strapped to battery B.

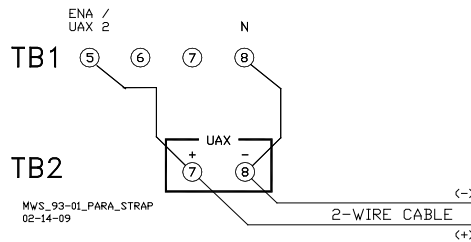


Figure 10-24:
UAX 1 (TB2-7 & TB2-8) Wired in Parallel
to UAX/ENA 2 (TB1-5) and N (TB1-8)

10.9.5.2 Double Track Installations with Active ENA from a Remote DAX location

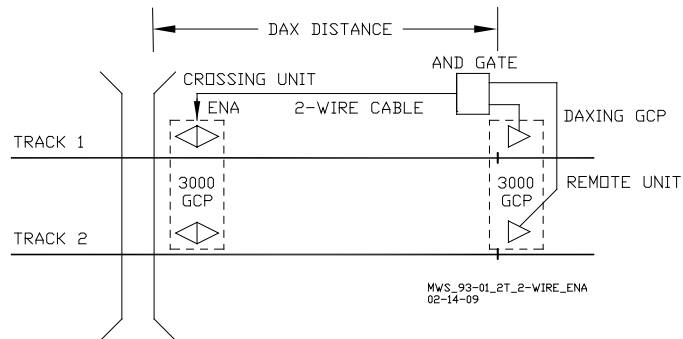


Figure 10-25:
DAX Programming Requirements
(Double Track, Dual GCPs, Active ENA From a Remote DAX Location Via AND Gate)

WARNING

IF THE REMOTE DAXING GCP'S ARE OTHER THAN 3000/4000 GCP'S (MODEL 660, 400, HXP, ETC.), THIS APPLICATION CANNOT BE USED. INDEPENDENT UAX CONTROLS AND THEIR PROGRAMMING APPLICATION, MUST OR USED AS ILLUSTRATED AND DISCUSSED IN

PARAGRAPH 10.9.5.3.

1. Program ENA/UAX 2 for zero (0) time (activates Enable operation for both tracks). Ensure ENA terminal is not strapped to battery B.
2. Set the DAX pickup delay times at the remote DAX location for 15 seconds, or to the value presently programmed if longer. At the remote predictor, program DAX A to T1 and DAX B to T2.
3. If prime prediction offset is used at the remote DAXes, program the remote prime pickup delays for 15 seconds or to the value presently programmed if longer. In addition, if prime predictors are used at the remote (prime prediction offset) then the AND GATE is not required so use the GCP output terminals (Note: T1 prime and T2 prime are already internally ANDed).

NOTE

The actual DAX pickup delay for through-move trains is automatically computed to recover shortly after a train arrives at the street.

4. Since the UAX input is not used (no wires connected to the UAX terminals), program UAX 1 for zero (0) time (OFF).

10.9.5.3 Double Track Installations with Independent UAX Controls for Each Track

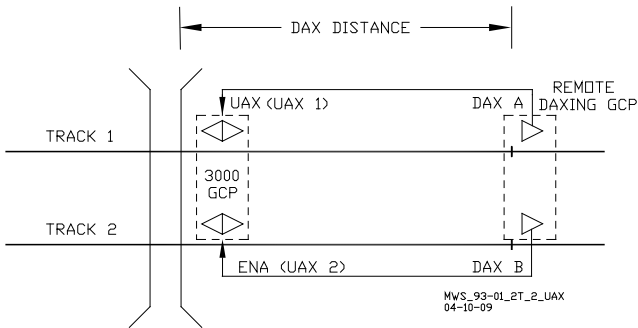


Figure 10-26:
DAX Programming Requirements
(Double Track, Dual GCPs, Independent UAX For Each Track)

NOTE

The remote DAX's may be any model GCP (3000, 4000, 660, 400, HXP, etc.) when independent UAX 1 and Enable/UAX 2 inputs are used for track 1 and track 2, respectively.

For new crossing designs where separate UAX two-wire circuits for track 1 and track 2 are used (see Figure 10-26), or where an existing installation is to be converted to separate two-wire UAX circuits, program the GCP as follows:

1. Program UAX 1 for 25 seconds.
2. Program ENA/UAX 2 for 25 seconds.
3. Use T1DAX A and T2 DAX B for remote predictors. Program each DAX pickup delay times for track 1 and track 2 at the remote location for 15 seconds, or to the value presently programmed if longer.

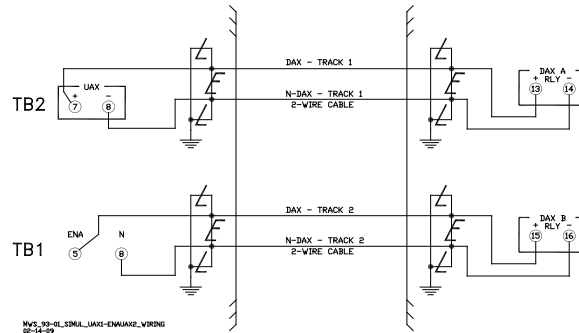


Figure 10-27:
Typical Simultaneous UAX 1 and ENA/UAX 2 Wiring Diagram

10.10 Enable (ENA) application programming

NOTE

The following applications in paragraphs 10.10.1 and 10.10.2 are based upon all units being Model 3000 family GCPs.

10.10.1 Use of ENA Terminal for Cascading Multiple GCP Units at the Crossing

Cascading using the “ENABLE” function allows for two or more GCP Cases in single or multiple track applications at a crossing to provide a single GCP RLY output to the XR. This GCP RLY output combines all prime predictors together (ANDed) of multiple GCP cases to provide a single XR control. It also provides an accurate recording of crossing warning times in the GCP History and the Data Recorder.

As an example, Figure 10-28 is a double track installation with back-to-back GCP units. GCP1 has the (+) GCP RLY output terminal (TB1-9) wired to GCP2 ENA/UAX2 terminal (TB1-5) and its (-) output wired to the Battery N terminal (TB1-8) of GCP2. The GCP2 ENA/UAX2 terminal is programmed to 0 (zero) pickup delay (ENABLE function). Whenever T1 or T2 prime predictors predicts in GCP1, the GCP2 Enable de-energizes and causes both T1 and T2 prime predictors on GCP2 to de-energize and drop the GCP RLY of GCP2. The ENABLE is used (instead of UAX1 or UAX2) because when de-energized, it starts the warning time timers in GCP2 for both T1 and T2, thus producing accurate warning times for train moves either track.

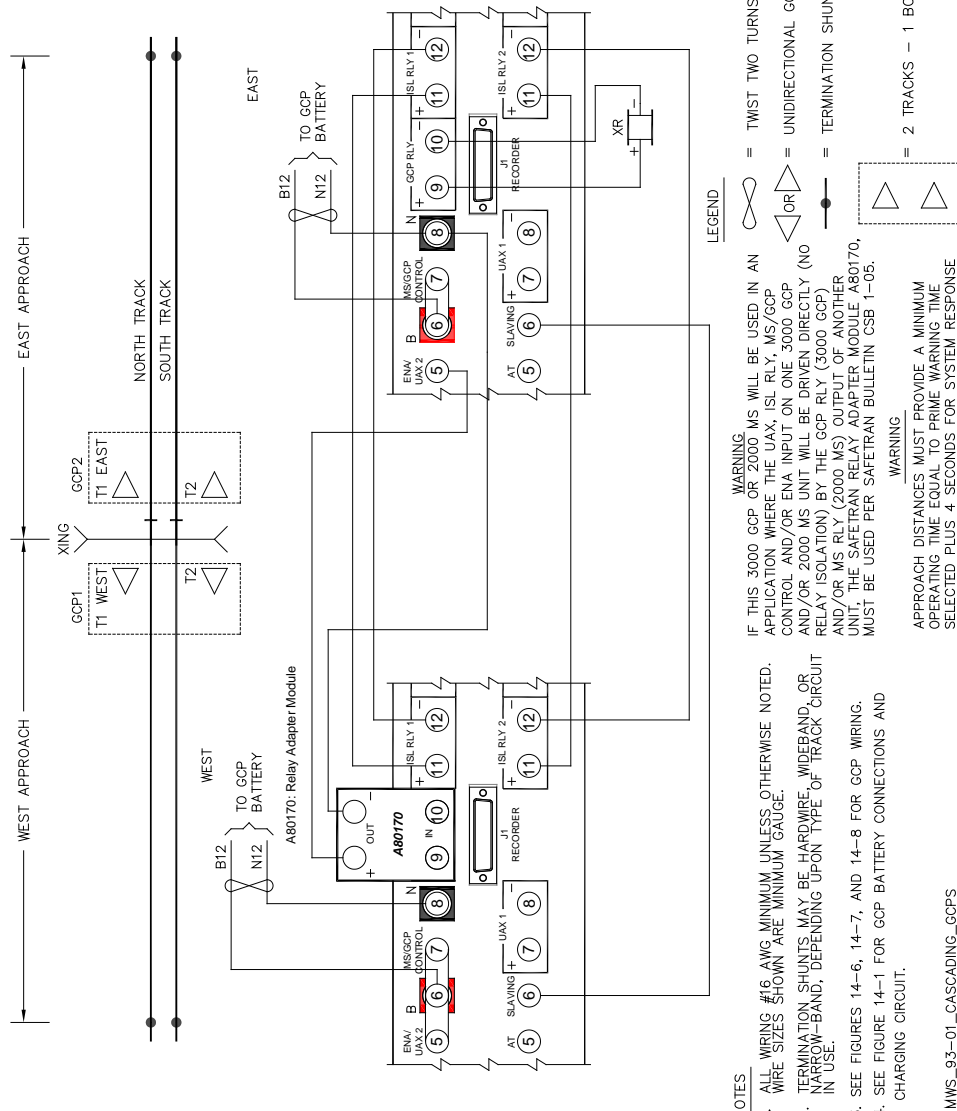


Figure 10-28:
Model 3000/3000D2 GCP Typical Unidirectional Application
with Frequency Slaving and Cascaded Relay Drives, Two Tracks

10.10.2 Use of ENA (ENABLE) for Cascading Remote Predictors with Offset Distances

When there are two remote DAX locations in one crossing approach, there are two options for cascading the two remotes. Option A uses prime predictors at the remotes and Option B uses DAX predictors (80016 Module) at the remotes.

10.10.2.1 Option A – Prime Predictors at the Remotes

In Figure 10-29, the two remote GCPs have their prime predictors ANDed together (cascaded) by using the ENABLE at GCP2. The application is as follows:

NOTES:

1. ALL WIRING #16 AWG MINIMUM UNLESS OTHERWISE NOTED. WIRE SIZES SHOWN ARE MINIMUM GAUGE.
2. TERMINATION SHUNTS MAY BE HARDWIRE WIDEBAND OR NARROW-BAND, DEPENDING UPON TYPE OF TRACK CIRCUIT IN USE.
3. SEE FIGURES 14-6, 14-7, AND 14-8 FOR GCP WIRING.
4. SEE FIGURE 14-1 FOR GCP BATTERY CONNECTIONS AND CHARGING CIRCUIT.

LEGEND

∞ = TWIST TWO TURNS PER FOOT
 ◊ = UNIDIRECTIONAL GCP UNIT
 ● = TERMINATION SHUNT
 [] = 2 TRACKS - 1 BOX

WARNING
 IF THIS 3000 GCP OR 2000 MS WILL BE USED IN AN APPLICATION WHERE THE UAX, ISL RLY, MS/GCP CONTROL AND/OR ENA INPUT ON ONE 3000 GCP AND/OR 2000 MS UNIT WILL BE DRIVEN DIRECTLY (NO RELAY ISOLATION) BY THE GCP RLY (3000 GCP) AND/OR MS RLY (2000 MS) OUTPUT OF ANOTHER UNIT, THE SAFETRAIN RELAY ADAPTER MODULE A80170, MUST BE USED PER SAFETRAIN BULLETIN CSB 1-05.

WARNING
 APPROACH DISTANCES MUST PROVIDE A MINIMUM OPERATING TIME EQUAL TO PRIME WARNING TIME SELECTED PLUS 4 SECONDS FOR SYSTEM RESPONSE TIME AT MAXIMUM TRAIN SPEED.

MWS_93-01_CASCADING_GCPs
 03-20-09

1. GCP3: Program T1 prime prediction offset for the distance to the crossing (2012 feet)
2. GCP3: Wire GCP output to line circuit to GCP2 ENA input
3. GCP2: Program ENA/UAX2 input for 0 (zero) seconds
4. GCP2: Program T1 and T2 prime prediction offsets for the distance to the crossing (both are set to 1455 feet)
5. GCP2: Wire GCP output to line circuit to GCP1 ENA input
6. GCP1: Program ENA/UAX2 input for 0 (zero) seconds (ENABLE)

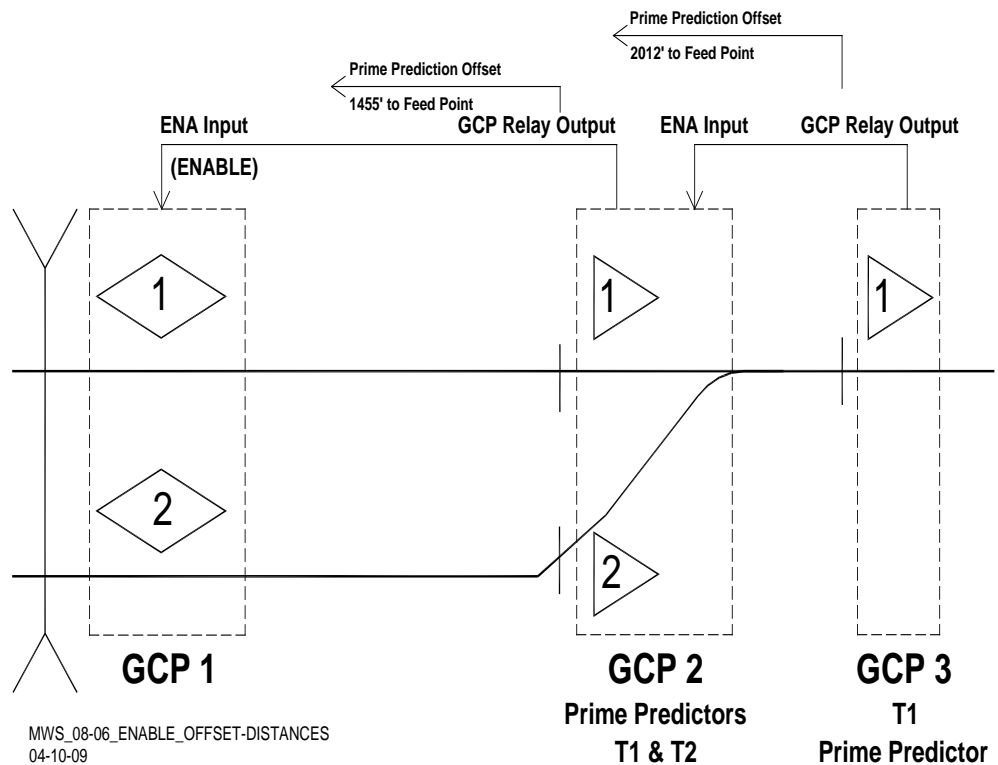


Figure 10-29:
Cascading Remote Predictors Using Offset Distances

10.10.2.2 Option B – DAX Predictors ANDed Using a Vital 4-Input AND-Gate

In Figure 10-30, the two remote GCPs have their DAX predictors ANDed together (cascaded) by using the Solid State Vital 4-Input AND-Gate, 91082. The application is as follows:

1. GCP3: Program T1 prime prediction offset for the distance to the crossing (2012 feet)
2. GCP3: Wire GCP output to line circuit. The line circuit drives 2 inputs of the Vital 4-Input AND-Gate located at GCP2.
3. GCP2: Program DAX A to T1 and DAX B to T2.
4. GCP2: Program T1 DAX A predictor offset distance for the distance to the crossing (1455 feet). Wire DAX A output to an input of the Vital 4-Input AND-Gate.
5. GCP2: Program T1 DAX A predictor offset distance for the distance to the crossing (1455 feet). Wire DAX A output to an input of the Vital 4-Input AND-Gate.
6. GCP2: Wire output of Vital 4-Input AND-Gate to line circuit going to GCP1.

Line circuit terminates at GCP1 ENA/UAX2 input.
 7. GCP1: Program ENA input for 0 (zero) seconds (ENABLE).

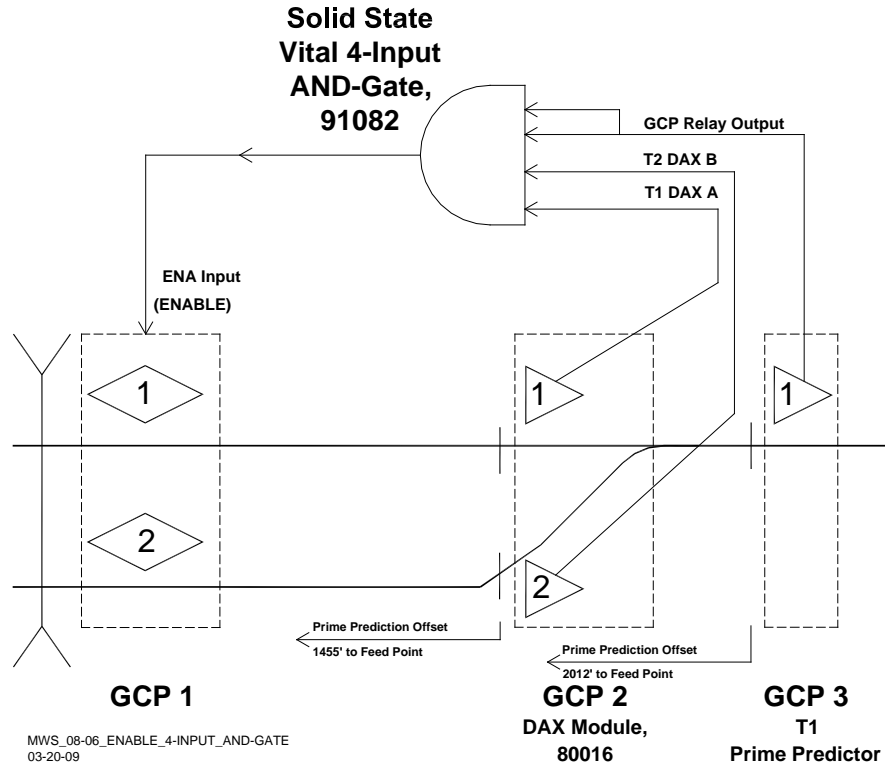


Figure 10-30:
Cascading Remote Predictors using Vital 4-Input AND-Gate

SECTION 12

Added sections pertaining to the following items of equipment:

- Relay Adapter Module, 80170
- 3000 GCP Slaving Unit, 80065
- MS/GCP to Network Interface Plug Assembly, 80063
- Simulated Track Assembly, 80071
- Six-Wire Simulated Track Burial Assembly, 80074
- DC Shunting Enhancer Panel, 80049
- Vital AND-Gate, 4-Input, 91082

Section Wide:

Re-ordered placement of all Auxiliary Equipment

Renumbered all Tables and Figures

Added sections pertaining to the following items of equipment:

- Relay Adapter Module, 80170
- 3000 GCP Slaving Unit, 80065
- MS/GCP to Network Interface Plug Assembly, 80063
- Simulated Track Assembly, 80071
- Six-Wire Simulated Track Burial Assembly, 80074
- DC Shunting Enhancer Panel, 80049
- Vital AND-Gate, 4-Input, 91082

		<p><u>SECTION 13</u></p> <p>Page 13-11, WARNING Deleted MS/GCP; Inserted Prime</p> <p>Page 13-12, Changed NOTE: When UAX2 is programmed to zero (0) seconds, the terminal functions as ENA with no pickup delay and is typically used for cascading multiple GCP outputs.</p> <p>Page 13-13, Step 13.2: Inserted: The default for track 1 is A, C, E, & G. The default for track 2 is B, D, G, & H.</p> <p>Page 13-17, Inserted NOTE following Step 17.18: Inserted: Steps 18 through 25.2 apply to the Data Recorder Module (80015/80115). Perform these steps as required.</p> <p>Page 13-26, Changed WARNING Inserted: If rust were to build up to a degree that no track shunting occurs (EZ dows not change), the Model 3000 GCP will not sense train movements.</p> <p>Page 13-27, NOTE bulleted sections: Third bullet, Inserted: "A minimum of" to beginning of bullet statement Fifth bullet: Deleted original bullet. Inserted: Narrow-band termination shunts must be used. Do not use wideband or hardwire shunts for terminations.</p> <p>Page 13-28, WARNING: Inserted: In software versions J and earlier,...(minimum value)...</p> <p>Page 13-28, NOTE 1 Inserted: In software versions J and earlier,</p> <p>Page 13-30, NOTE 2 Inserted: ... of SIG-00-00-02, Model 3000 GCP Instruction and Installation Manual,...for Low EX Test Procedure.</p> <p>Page 130-31, NOTE 2 Inserted: ... of SIG-00-00-02, Model 3000 GCP Instruction and Installation Manual</p> <p>Page 13-32, Step 41.1 NOTE Inserted: When programmed, the positive start function enables the activation of the crossing warning device whenever the track circuit EZ level drops below the programmed positive start EZ value.</p>
D1	August 2014	Rebrand for Siemens
D2	Sept. 2014	<p>Page 4-2, Section 4.2 ISLAND MODULE, 80011-F/80211</p> <p>Added the following note:</p> <p>In certain applications with adverse ballast conditions the IP track circuit may experience interference from islands with the same frequency at distances further than 5000 feet.</p>

This page intentionally left blank

NOTES, CAUTIONS, AND WARNINGS

Throughout this manual, notes, cautions, and warnings are frequently used to direct the reader's attention to specific information. Use of the three terms is defined as follows:

WARNING

WARNING

INDICATES A POTENTIALLY HAZARDOUS SITUATION WHICH, IF NOT AVOIDED, COULD RESULT IN DEATH OR SERIOUS INJURY. WARNINGS ALWAYS TAKE PRECEDENCE OVER NOTES, CAUTIONS, AND ALL OTHER INFORMATION.

CAUTION

CAUTION

REFERS TO PROPER PROCEDURES OR PRACTICES WHICH IF NOT STRICTLY OBSERVED, COULD RESULT IN A POTENTIALLY HAZARDOUS SITUATION AND/OR POSSIBLE DAMAGE TO EQUIPMENT. CAUTIONS TAKE PRECEDENCE OVER NOTES AND ALL OTHER INFORMATION, EXCEPT WARNINGS.

NOTE

NOTE

Generally used to highlight certain information relating to the topic under discussion.

If there are any questions, contact Siemens Industry Inc., Rail Automation Application Engineering.

ELECTROSTATIC DISCHARGE (ESD) PRECAUTIONS

Static electricity can damage electronic circuitry, particularly low voltage components such as the integrated circuits commonly used throughout the electronics industry. Therefore, procedures have been adopted industry-wide which make it possible to avoid the sometimes invisible damage caused by electrostatic discharge (ESD) during the handling, shipping, and storage of electronic modules and components. Siemens Industry, Inc., Rail Automation has instituted these practices at its manufacturing facility and encourages its customers to adopt them as well to lessen the likelihood of equipment damage in the field due to ESD. Some of the basic protective practices include the following:

- Ground yourself before touching card cages, assemblies, modules, or components.
- Remove power from card cages and assemblies before removing or installing modules.
- Remove circuit boards (modules) from card cages by the ejector lever only. If an ejector lever is not provided, grasp the edge of the circuit board but avoid touching circuit traces or components.
- Handle circuit boards by the edges only.
- Never physically touch circuit board or connector contact fingers or allow these fingers to come in contact with an insulator (e.g., plastic, rubber, etc.).
- When not in use, place circuit boards in approved static-shielding bags, contact fingers first. Remove circuit boards from static-shielding bags by grasping the ejector lever or the edge of the board only. Each bag should include a caution label on the outside indicating static-sensitive contents.
- Cover workbench surfaces used for repair of electronic equipment with static dissipative workbench matting.
- Use integrated circuit extractor/insertor tools designed to remove and install electrostatic-sensitive integrated circuit devices such as PROM's (OK Industries, Inc., Model EX-2 Extractor and Model MOS-40 Insertor (or equivalent) are highly recommended).
- Utilize only anti-static cushioning material in equipment shipping and storage containers.

For information concerning ESD material applications, please contact the Technical Support Staff at 1-800-793-7233. ESD Awareness Classes and additional ESD product information are also available through the Technical Support Staff.

TABLE OF CONTENTS

Section	Title	Page
	PROPRIETARY INFORMATION	ii
	TRANSLATIONS.....	ii
	WARRANTY INFORMATION	ii
	SALES AND SERVICE LOCATIONS	ii
	FCC RULES COMPLIANCE.....	ii
	DOCUMENT HISTORYiii
	NOTES, CAUTIONS, AND WARNINGS.....	xxi
	ELECTROSTATIC DISCHARGE (ESD) PRECAUTIONS.....	xxii
SECTION 1 – INTRODUCTION.....		1-1
1.1 GENERAL.....		1-1
1.2 SYSTEM SPECIFICATIONS		1-2
1.3 MODES OF OPERATION		1-3
1.4 APPLICATION CONFIGURATIONS: BIDIRECTIONAL, UNIDIRECTIONAL, AND BIDIRECTIONAL SIMULATION		1-4
1.5 UNIDIRECTIONAL OR BIDIRECTIONAL?		1-4
SECTION 2 – COMPATIBILITY WITH VARIOUS TYPE OF TRACK CIRCUITS.....		2-1
SECTION 3 – GCP FREQUENCY SELECTION		3-1
3.1 GENERAL.....		3-1
3.2 DC CODE (RELAY)		3-1
3.3 STEADY ENERGY 100 HZ		3-1
3.4 STYLE C TRACK CIRCUITS.....		3-1
3.5 60 AND 100 HZ AC CODED TRACK OR CODED CAB SIGNAL CIRCUITS.....		3-1
3.6 LOADING EFFECT OF NARROW-BAND SHUNTS (62775-F AND 62780-F) AND TERMINATIONS.....		3-2
3.7 OTHER AC SIGNALS ON THE TRACK.....		3-7
3.8 APPROACH LENGTH CALCULATION.....		3-7
3.8.1 Preempting Traffic Signals.....		3-8
3.9 MINIMUM APPROACH LENGTH VERSUS FREQUENCY FOR MODEL 3000 GCP'S CONTROLLING TWO-TRACK CIRCUITS.....		3-8
3.10 BALLAST RESISTANCE VERSUS APPROACH LENGTH (BIDIRECTIONAL AND UNIDIRECTIONAL APPLICATIONS).....		3-10
3.11 MULTIPLE TRACK CROSSINGS (SLAVING/NONSLAVING)		3-12
3.12 REPEATING 3000 GCP OPERATING FREQUENCIES.....		3-14
SECTION 4 – ISLAND FREQUENCY SELECTION AND ISLAND LENGTH.....		4-1

4.1 GENERAL.....	4-1
4.2 ISLAND MODULE, 80011-F/80211	4-1
4.3 DC ISLAND CIRCUIT	4-2
SECTION 5 – TERMINATION SHUNTS.....	5-1
5.1 GENERAL.....	5-1
5.2 MINIMUM APPROACH DISTANCES, NARROW-BAND SHUNT TERMINATIONS	5-1
5.3 TERMINATION SHUNTS AT INSULATED JOINTS	5-2
5.4 INSTALLATION OF NARROW-BAND TERMINATION SHUNTS IN EXISTING MS/GCP APPROACHES	5-2
SECTION 6 – BYPASSING INSULATED JOINTS	6-1
6.1 GENERAL.....	6-1
6.2 WIDEBAND SHUNTS.....	6-1
6.3 TUNABLE INSULATED JOINT BYPASS COUPLERS	6-1
6.4 INSULATED JOINT BYPASS SHUNT/COUPLER INSTALLATION	6-1
6.5 MS/GCP TERMINATION SHUNT BURIAL KIT, A62776	6-1
6.6 UNIDIRECTIONAL INSTALLATIONS	6-2
6.7 STEADY ENERGY DC TRACK CIRCUIT (NO CAB SIGNAL)	6-2
6.8 CODED DC TRACK CIRCUIT	6-2
6.9 AC TRACK CIRCUITS OR CAB SIGNAL TERRITORY.....	6-4
SECTION 7 – TRACK LEADS	7-1
7.1 GENERAL.....	7-1
7.2 TRACK WIRE REQUIREMENTS VS. APPROACH LENGTH FOR MULTIPLE TRACK INSTALLATIONS	7-2
7.3 REQUIREMENTS FOR SIX-WIRE HOOKUP	7-4
7.4 SIX-WIRE SIMULATED BIDIRECTIONAL INSTALLATIONS.....	7-4
7.5 3000 GCP SYSTEMS THAT SHARE TRACK WIRES WITH EXTERNAL TRACK CIRCUIT EQUIPMENT.....	7-5
7.5.1 6-WIRE CONNECTIONS.....	7-5
7.5.2 4-WIRE CONNECTIONS.....	7-5
SECTION 8 – TRACK CIRCUIT ISOLATION	8-1
8.1 GENERAL.....	8-1
8.2 STEADY ENERGY DC TRACK CIRCUITS.....	8-1
8.3 GEO ELECTRONIC DC CODED SYSTEM	8-2
8.4 ELECTRO CODE ELECTRONIC DC CODED SYSTEM	8-2
8.5 RELAY CODED DC TRACK.....	8-2
8.5.1 Single (Fixed) Polarity Systems.....	8-3
8.5.2 GRS Trakode (Dual Polarity) Systems	8-3
8.5.3 Dual Polarity (Polar) Coded Track Systems Other Than GRS Trakode.....	8-3
8.6 CAB SIGNAL AC	8-4

8.7 STYLE C TRACK CIRCUITS.....	8-4
SECTION 9 – UNIDIRECTIONAL OPERATION.....	9-1
9.1 GENERAL.....	9-1
9.1.1 RELAY ADAPTER MODULE, A80170	9-1
9.2 UNIDIRECTIONAL OPERATION - BIDIRECTIONAL SIMULATION.....	9-2
9.3 BIDIRECTIONAL SIMULATION COUPLER, 62664-MF	9-2
9.4 SIMULATED TRACK INDUCTOR, 8V617	9-2
9.5 INSULATED JOINTS LOCATED AT THE CROSSING.....	9-3
9.6 DC ISLAND CIRCUITS.....	9-6
SECTION 10 – 3000 GCP DAX APPLICATIONS.....	10-1
10.1 INTRODUCTION TO DAX OPERATION	10-1
10.2 CONTROLLING DOWNSTREAM CROSSINGS.....	10-3
10.3 MAJOR DAX APPLICATIONS.....	10-3
10.4 COMMON DAX APPLICATION GUIDELINES.....	10-5
10.5 PROGRAMMING FOR DAX OPERATION	10-5
10.5.1 Island (Distance)	10-5
10.5.2 Number Of DAX's.....	10-6
10.5.3 DAX Track (Track Assignment)	10-6
10.5.4 DAX Distance.....	10-6
10.5.5 DAX Warning Time	10-7
10.5.6 DAX Pickup Delay Time.....	10-7
10.6 PRIME PREDICTION OFFSET	10-8
10.7 SPECIAL APPLICATIONS FOR DAX MODULES	10-11
10.7.1 Traffic Signal Preemption (Through Move Train Traffic).....	10-12
10.7.2 Independent Relay Drive Outputs For Track 1 And Track 2.....	10-12
10.8 OS TRACK CIRCUITS	10-12
10.9 COMMON UAX APPLICATION GUIDELINES.....	10-18
10.9.1 Turning off the UAX1 and ENA/UAX2 functions	10-18
10.9.2 UAX1 and ENA/UAX2 input control of T1 and T2.....	10-18
10.9.3 Rules Regarding De-energizing Relay Drive Outputs Using Inputs UAX1, UAX2 and ENA.	10-19
10.9.4 Single Track UAX and ENA Applications.....	10-19
10.9.4.1 Single Track Using Separate GCPs with Active UAX Controlled from a Remote Location	10-19
10.9.4.2 Single Track Using Separate GCPs with Active ENA Controlled from a Remote Location	10-20
10.9.4.3 Single Track using Single GCP (No UAX or Enable Used).....	10-21
10.9.5 Double Track UAX/ENA Applications	10-21
10.9.5.1 Double Track Installations with Active UAX from a Remote DAX Location	10-21
10.9.5.2 Double Track Installations with Active ENA from a Remote DAX location.....	10-23
10.9.5.3 Double Track Installations with Independent UAX Controls for Each Track	10-24

10.10 ENABLE (ENA) APPLICATION PROGRAMMING.....	10-25
10.10.1 Use of ENA Terminal for Cascading Multiple GCP Units at the Crossing	10-25
10.10.2 Use of ENA (ENABLE) for Cascading Remote Predictors with Offset Distances	10-27
10.10.2.1 Option A – Prime Predictors at the Remotes.....	10-27
10.10.2.2 Option B – DAX Predictors ANDed Using a Vital 4-Input AND-Gate	10-27
SECTION 11 – UNEQUAL BIDIRECTIONAL APPROACH DISTANCES	11-1
SECTION 12 – AUXILIARY EQUIPMENT	12-1
12.1 GENERAL.....	12-1
12.2 SPECIFIC MODEL 3000 GRADE CROSSING PREDICTOR AUXILIARY EQUIPMENT	12-2
12.2.1 Automatic Transfer Timer Unit, 80024	12-2
12.2.2 Data Recorder Module, 80115.....	12-10
12.2.3 Data Recorder Interface Assembly, 80025	12-10
12.2.4 Relay Adapter Module, 80170	12-12
12.2.5 Extender Module, 80021	12-13
12.2.6 3000 GCP Slaving Unit, 80065	12-13
12.2.7 MS/GCP to Network Interface Plug Assembly, 80063.....	12-14
12.2.8 Simulated Track Assembly, 80071	12-15
12.2.8.1 Instructions For Taking a Track Out of Service	12-15
12.2.9 Returning a Track to Service	12-17
12.3 GENERIC GRADE CROSSING PREDICTOR AUXILIARY EQUIPMENT.....	12-18
12.3.1 Bidirectional Simulation Coupler, 62664-MF.....	12-18
12.3.2 MS/GCP Termination Shunt Burial Kit, A62776	12-22
12.3.3 Six-Wire Simulated Track Burial Assembly, 80074	12-23
12.3.4 DC Shunting Enhancer Panel, 80049	12-23
12.3.5 Vital AND-Gate, 2-Input 90975	12-26
12.3.6 Vital AND-Gate, 4-Input, 91082	12-29
12.4 TRACK CIRCUIT ISOLATION DEVICES	12-32
12.4.1 Steady Energy DC Track Circuits	12-32
12.4.1.1 Battery Chokes, 62648 & 8A065	12-33
12.4.2 Safetran GEO Electronic DC Coded System.....	12-34
12.4.3 Electro Code Electronic Coded System.....	12-34
12.4.4 Relay Coded DC Track	12-34
12.4.4.1 DC Code Isolation Units, 6A342-1 & 6A342-3	12-34
12.4.5 Single Polarity Systems (Fixed Polarity)	12-36
12.4.6 GRS Trakode (Dual Polarity) Systems	12-36
12.4.7 Dual Polarity (Polar) Coded Track Systems Other Than GRS Trakode.....	12-36
12.4.8 AC Cab Signal.....	12-36
12.4.8.1 AC Code Isolation Unit, 8A466.....	12-37
12.4.8.2 AC Code Isolation Unit, 8A471-100 & 8A471-180	12-37
12.4.9 Style C Track Circuits.....	12-38
12.5 COUPLERS AND SHUNTS.....	12-40

12.5.1 Tunable Insulated Joint Bypass Coupler, 62785-F	12-40
12.5.2 Narrow-Band Shunt, 62775-f	12-42
12.5.3 Narrow-Band Shunt, 62780-f	12-43
12.5.4 Adjustable Inductor Assembly, 8A398-6 (Used With Single- Frequency Shunts Only) ...	12-44
12.5.5 Multifrequency Narrow-Band Shunt, 62775-XXXX	12-46
12.5.6 Multifrequency Narrow-Band Shunt, 62780-XXXX	12-48
12.5.7 Simulated Track Inductor, 8V617 (Used With Multifrequency Shunts Only)	12-49
12.5.8 Wideband Shunt, 8A076A.....	12-52
12.6 SURGE SUPPRESSION PANELS, 80026-XX.....	12-52
12.6.1 Surge Panels 80026-01, -02, -22, --1, -32, -33, -34, -35, -36, -37, -38, -39, -41, -41A, & -50	12-52
12.7 AUXILIARY EQUIPMENT PANELS	12-61
12.7.1 Rectifier Panel Assembly, 80033.....	12-61
12.7.2 Cable Termination Panel Assembly, 91042.....	12-61
12.7.3 Data Recorder Interface & Vital AND-Gate Driver Panel Assembly, 91043.....	12-62
12.7.4 Vital AND-Gate Driver Panel Assembly, 91044.....	12-62
SECTION 13 3000 GCP SYSTEM PROGRAMMING PARAMETERS.....	13-1
13.1 GENERAL.....	13-1
13.2 MAKING PROGRAM CHANGES	13-3
13.3 SYSTEM PROGRAMMING	13-5
13.3.1 SET TO DEFAULT.....	13-6
13.3.2 APPLICATION PROGRAMMING	13-6
13.3.3 ENABLE PASSWORD.....	13-12
13.3.4 CHANGE PASSWORD.....	13-12
13.3.5 DISABLE PASSWORD.....	13-13
13.3.6 DATA RECORDER PROGRAMMING.....	13-14
13.3.7 EXTENDED APPLICATION PROGRAMMING	13-17
13.4 CONDENSED PROGRAMMING PROCEDURES	13-29
SECTION 14 – MODEL 3000 GCP APPLICATION DIAGRAMS.....	14-1
SECTION 15 – SURGE PROTECTION.....	15-1
15.1 GENERAL.....	15-1
15.2 AC POWER LINES.....	15-1
15.3 BATTERY	15-1
15.4 TRACK WIRES.....	15-1
15.5 LINE CIRCUITS.....	15-1

List of Figures

Figure 3-1:	Adjacent Channel Frequency Narrow-band Shunt (86 & 114 Hz) Placement Charts, Bidirectional Applications	3-3
Figure 3-2:	Adjacent Channel Frequency Narrow-band Shunt (156, 211, & 285 Hz) Placement Charts, Bidirectional Applications	3-4
Figure 3-3:	Adjacent Channel Frequency Narrow-band Shunt (348, 430, & 525 Hz) Placement Charts, Bidirectional Applications	3-5
Figure 3-4:	Adjacent Channel Frequency Narrow-band Shunt (645, 790, & 970 Hz) Placement Charts, Bidirectional Applications	3-6
Figure 3-5:	PSO II Vs. 3000 GCP Frequency Compatibility.....	3-7
Figure 3-6:	Minimum Approach Lengths	3-8
Figure 3-7:	Ballast Resistance Versus Approach Length By Frequency - Bidirectional Application..	3-11
Figure 3-8:	Ballast Resistance Versus Approach Length By Frequency - Unidirectional Application	3-12
Figure 3-9:	Master/Slave GCP Operation – Same Frequency.....	3-13
Figure 3-10:	Master/Slave GCP Operation – Different Frequencies.....	3-13
Figure 3-11:	Overlapping Approach Distances	3-14
Figure 4-1:	Typical Island and Approaches.....	4-1
Figure 4-2:	Multiple High-Frequency Island Circuits	4-2
Figure 4-3:	DC Track Circuit Island Relay Strapping	4-3
Figure 6-1:	Tunable Insulated Joint Bypass Coupler Installation	6-4
Figure 7-1:	Minimum Approach Lengths	7-2
Figure 7-2:	Proper Connections of Track Wires	7-6
Figure 8-1:	Typical Battery Choke Application	8-1
Figure 8-2:	Typical Rectified Track Application	8-2
Figure 8-3:	Single Polarity System	8-3
Figure 8-4:	GRS Dual Polarity System Application	8-3
Figure 8-5:	Typical Code Isolation Application in Cab Signal Territory.....	8-4
Figure 8-6:	Typical Style C Application	8-4
Figure 9-1:	A80170 Relay Adapter Module	9-1
Figure 9-2:	Connecting Island Relays with Insulated Joints at the Crossing	9-3
Figure 9-3:	Track Wiring Connections with Insulated Joints at the Crossing	9-4
Figure 9-4:	Relay Drive Output for Prime Prediction Offset In Unidirectional Application	9-4
Figure 9-5:	Unidirectional GCP in Same Case with Bidirectional GCP DAXing to Other Crossings	9-5
Figure 9-6:	Wiring of Island Relay Connections in DC Island Circuits	9-6
Figure 10-1:	Typical DAX Application.....	10-1
Figure 10-2:	Typical DAX/UAX Connections Using Vital AND Gate, 90975.....	10-2
Figure 10-3:	DAX From A Remote Siding	10-3
Figure 10-4:	DAX in DC Coded Track without Bypass Couplers	10-4
Figure 10-5:	DAX From A Remote Siding without Bypass Couplers	10-4
Figure 10-6:	DAX to Provide Remote Start From Another Crossing.....	10-5
Figure 10-7:	Determining DAX Distance	10-6
Figure 10-8:	Minimum DAX Distance	10-7
Figure 10-9:	DAX Pickup Delay.....	10-8
Figure 10-10:	Programming Prime Prediction Offset	10-9
Figure 10-11:	Minimum Approach Length with Prime Prediction Offset	10-9
Figure 10-12:	Back-to-Back Model 3000 GCP Application	10-10
Figure 10-13:	Island Relay Strapping in Back-to-Back Application.....	10-10
Figure 10-14:	Two GCPs in Back-to-Back Application on Double Track	10-11
Figure 10-15:	Strapping Island Relays on Two GCPS in Back-to-Back Application on Double Track	10-11
Figure 10-16:	Typical Bidirectional Two-Track Application With Independent GCP Outputs	10-14
Figure 10-17:	Typical Programming Data for Bidirectional Two- Track Application with Independent GCP Outputs.....	10-15

Figure 10-18:	Typical Model 3000 GCP Application In An OS Track Circuit	10-16
Figure 10-19:	Series Track Circuit Conversion for Motion Sensor Operation	10-17
Figure 10-20:	DAX Programming Requirements (Single Track, Dual GCP, UAX Controlled From Remote Location)	10-19
Figure 10-21:	DAX Programming Requirements (Single Track, Dual GCP, ENA Controlled From Remote Location)	10-20
Figure 10-22:	DAX Programming Requirements (Single Track, Crossing and Remote GCPs (T1 and T2) in Same GCP Case)	10-21
Figure 10-23:	DAX Programming Requirements (Double Track, Dual GCPs, Active UAX From a Remote DAX Location Via AND Gate).....	10-22
Figure 10-24:	UAX 1 (TB2-7 & TB2-8) Wired in Parallel to UAX/ENA 2 (TB1-5) and N (TB1-8).....	10-23
Figure 10-25:	DAX Programming Requirements (Double Track, Dual GCPs, Active ENA From a Remote DAX Location Via AND Gate).....	10-23
Figure 10-26:	DAX Programming Requirements (Double Track, Dual GCPs, Independent UAX For Each Track).....	10-24
Figure 10-27:	Typical Simultaneous UAX 1 and ENA/UAX 2 Wiring Diagram	10-25
Figure 10-28:	Model 3000/3000D2 GCP Typical Unidirectional Application with Frequency Slaving and Cascaded Relay Drives, Two Tracks.....	10-26
Figure 10-29:	Cascading Remote Predictors Using Offset Distances	10-27
Figure 10-30:	Cascading Remote Predictors using Vital 4-Input AND-Gate.....	10-28
Figure 11-1:	Simulated Track Added to Balance Unequal Bidirectional Approach Distance.....	11-1
Figure 12-1:	Automatic Transfer Timer Unit, 80024	12-3
Figure 12-2:	Location of Transfer Interval Select Switch (S1) On 80023 Module.....	12-3
Figure 12-3:	Automatic Transfer Timer Unit Mounting Dimensions	12-8
Figure 12-4:	Typical Single Track, Bidirectional Application with Automatic Transfer Timer Unit And Two 3000 GCPs.....	12-9
Figure 12-5:	Data Recorder Interface Assembly, 80025.....	12-11
Figure 12-6:	Data Recorder Interface Assembly Mounting Dimensions	12-11
Figure 12-7:	80170 Relay Adapter Module	12-13
Figure 12-8:	3000 GCP Slaving Unit, 80065	12-14
Figure 12-9:	MS/GCP to Network Interface Plug Assembly, 80063.....	12-15
Figure 12-10:	Simulated Track Inductor Assembly, 80071	12-17
Figure 12-11:	Bidirectional Simulation Coupler, 62664-Mf.....	12-18
Figure 12-12:	Bidirectional Simulation Coupler (62664) Assembly Mounting Dimensions.....	12-20
Figure 12-13:	Typical Unidirectional 3000 GCP Installation With Bidirectional Simulation Applied To East Approach.....	12-21
Figure 12-14:	MS/GCP Termination Shunt Burial Kit, A62776	12-22
Figure 12-15:	Six-wire Simulated Track Burial Assembly, 80074	12-23
Figure 12-16:	DC Shunting Enhancer Panel, 80049.....	12-24
Figure 12-17:	DC Shunting Enhancer Panel, 80049, Typical Application With Overlapping Track Circuits	12-25
Figure 12-18:	Vital AND-Gate, 2-Input, 90975	12-26
Figure 12-19:	Typical Solid-state Vital And-Gate Application	12-27
Figure 12-20:	Solid-state Vital Gate Assembly Mounting Dimensions.....	12-28
Figure 12-21:	Vital AND Gate, 4-Input, 91082	12-29
Figure 12-22:	4-input Vital AND Gate Assembly Mounting Dimensions	12-31
Figure 12-23:	Battery Choke Requirements.....	12-32
Figure 12-24:	62648/8A065A Battery Choke With Mounting Dimensions	12-33
Figure 12-25:	Ripple Elimination Circuit	12-33
Figure 12-26:	DC Code Isolation Unit, 6A342-01, With Mounting Dimensions.....	12-35
Figure 12-27:	Typical 6A342-1 Code Isolation Unit Installation in a Single Polarity Code System ..	12-36
Figure 12-28:	Typical 6A342-3 Code Isolation Unit Installation in a GRS Trakode System	12-36
Figure 12-29:	Typical AC Code Isolation Unit Installation Application	12-37
Figure 12-30:	AC Code Isolation Unit, 8A466	12-38
Figure 12-31:	60 Hz AC Code Isolation Unit Installation in Style C Track Circuit.....	12-38
Figure 12-32:	180 Hz AC Code Isolation Unit, 8A471-100 & -180, With Mounting Dimensions.....	12-39

Figure 12-33:	Terminal Identification, 62785-f Tunable Insulated Joint Bypass Coupler.....	12-41
Figure 12-34:	Typical Installation Diagrams Using the Tunable Insulated Joint Bypass (IJB) Coupler, 62785-f	12-41
Figure 12-35:	Adjustable Inductor Assembly, 8A398-6	12-44
Figure 12-36:	Adjustable Inductor, 8A398-6 Schematic.....	12-44
Figure 12-37:	Adjustable Inductor Used with Termination Shunt.....	12-45
Figure 12-38:	Typical Simulated Track Inductor, 8V617, Application	12-49
Figure 12-39:	Simulated Track Inductor, 8V617.....	12-49
Figure 12-40:	Typical Installation of Simulated Track Inductor, 8V617, in 62775/62780 Shunt	12-51
Figure 12-41:	Surge Panels, 80026-01, -02, -22	12-54
Figure 12-42:	Surge Panels, 80026-31 And -32.....	12-55
Figure 12-43:	Surge Panels, 80026-33 And -34.....	12-56
Figure 12-44:	Surge Panels, 80026-35 And -36.....	12-57
Figure 12-45:	Surge Panels, 80026-37 And -38.....	12-58
Figure 12-46:	Surge Panels, 80026-39, 41 and 41A.....	12-59
Figure 12-47:	Surge Panel, 80026-50	12-60
Figure 12-48:	Rectifier Panel Assembly, 80033	12-61
Figure 12-49:	Cable Termination Panel Assembly, 91042.....	12-61
Figure 12-50:	Data Recorder Interface And Vital AND-Gate Driver Panel Assembly, 91043.....	12-62
Figure 12-51:	Vital AND-Gate Driver Panel Assembly, 91044.....	12-62
Figure 14-1:	Recommended Surge Suppression Wiring for Microprocessor Based Grade Crossing Predictor, Model 3000 Family	14-4
Figure 14-2:	Typical Model 3000/3000D2 GCP Bidirectional Application, One Track, Case Wiring .	14-5
Figure 14-3:	Typical Model 3000/3000D2 GCP Bidirectional Application, One Track, Track Wiring.	14-6
Figure 14-4:	Typical Model 3000/3000D2 GCP Bidirectional Application, Two Tracks, Case Wiring	14-7
Figure 14-5:	Typical Model 3000/3000D2 GCP Bidirectional Application, Two Tracks, Track Wiring.	14-8
Figure 14-6:	Typical Model 3000/3000D2 GCP Unidirectional Application, One Track, Back-to-Back, Case Wiring.....	14-9
Figure 14-7:	Typical Model 3000/3000D2 GCP Unidirectional Application, One Track, Back-to-Back, Track Wiring.....	14-10
Figure 14-8:	Typical Model 3000/3000D2/3000D2L GCP Unidirectional Application, Two Tracks, Back-to-Back, Case Wiring	14-11
Figure 14-9:	Typical Model 3000/3000D2/3000D2L GCP Unidirectional Application, Two Tracks, Back-to-Back, Track Wiring.....	14-12
Figure 14-10:	Typical Model 3000ND/3000ND2 GCP Bidirectional Application, One Track	14-13
Figure 14-11:	Typical Model 3000ND/3000ND2 GCP Unidirectional Application, One Track.....	14-14
Figure 14-12:	Typical Model 3000ND/3000ND2 GCP Bidirectional Application with Crossover in MS/GCP Approach, Two Tracks (with Crossover Relay Logic), North Unit, Case Wiring	14-15
Figure 14-13:	Typical Model 3000ND/3000ND2 GCP Bidirectional Application with Crossover in MS/GCP Approach, Two Tracks (with Crossover Relay Logic), South Unit, Case Wiring	14-16
Figure 14-14:	Typical Model 3000ND/3000ND2 GCP Bidirectional Application with Crossover in MS/GCP Approach, Two Tracks (with Crossover Relay Logic), North or South Units, Track Wiring.....	14-17
Figure 14-15:	Proper Model 3000 GCP Four-Wire and Six-Wire Connections Using Auxiliary Track Circuit Equipment on 3000 GCP Operating in the Bidirectional Simulation Mode	14-18
Figure 14-16:	Typical Model 3000ND2 GCP Unidirectional Application with DC Island Track Circuit, One Track, Six Wire Hookup, Case Wiring.....	14-19
Figure 14-17:	Typical Model 3000ND2 GCP Unidirectional Application with DC Island Track Circuit, One Track, Six Wire Hookup, Track Wiring.....	14-20
Figure 14-18:	Typical Model 3000/3000D2 GCP Bidirectional Application with DC Island Track Circuit, One Track, Case Wiring.....	14-21
Figure 14-19:	Typical Model 3000/3000D2 GCP Bidirectional Application with DC Island Track Circuit, One Track, Track Wiring	14-22

Figure 14-20:	Typical Model 3000/3000D2 GCP Unidirectional Application with DC Island Track Circuit, One Track, Case Wiring.....	14-23
Figure 14-21:	Typical Model 3000/3000D2 GCP Unidirectional Application with DC Island Track Circuit, One Track, Track Wiring	14-24
Figure 14-22:	Typical Model 3000/3000D2 GCP Motion Sensor Application plus Track Wraps of MSR with Style 'C' Track Circuit, One Track, Case Wiring.....	14-25
Figure 14-23:	Typical Model 3000/3000D2 GCP Motion Sensor Application plus Track Wraps of MSR with Style 'C' Track Circuit, One Track, Track Wiring	14-26
Figure 14-24:	Typical Model 3000/3000D2 GCP Bidirectional Application with Remote Unidirectional Unit, One Track (Four-Wire), Case Wiring.....	14-27
Figure 14-25:	Typical Model 3000/3000D2 GCP Bidirectional Application with Remote Unidirectional Unit, One Track (Four-Wire), Track Wiring	14-28
Figure 14-26:	Typical Model 3000/3000D2 GCP Bidirectional Application, Unidirectional Unit With Remote Feed Point, One Track (Six-Wire), Case Wiring	14-29
Figure 14-27:	Typical Model 3000/3000D2 GCP Bidirectional Application, Unidirectional Unit with Remote Feed Point, One Track (Six-Wire), Track Wiring.....	14-30
Figure 14-28:	Typical Model 3000/3000D2 GCP Bidirectional UAX Interconnect Application with Remote Unidirectional Unit, One Track, Case Wiring.....	14-31
Figure 14-29:	Typical Model 3000/3000D2 GCP Bidirectional UAX Interconnect Application with Remote Unidirectional Unit, One Track, Track Wiring	14-32
Figure 14-30:	Typical Model 3000/3000D2/3000D2L GCP Unidirectional Application with Frequency Slaving and Cascaded Relay Drives, Two Tracks, Case Wiring	14-33
Figure 14-31:	Typical Model 3000/3000D2/3000D2L GCP Unidirectional Application with Frequency Slaving and Cascaded Relay Drives, Two Tracks, Track Wiring	14-34
Figure 14-32:	Typical Model 3000/3000D2 GCP Bidirectional Application with External Automatic Transfer, One Track.....	14-35
Figure 14-33:	Typical Model 3000/3000D2/3000D2L GCP DAX-UAX Interconnections, Two Crossings	14-36
Figure 14-34:	Typical Model 3000/3000D2/3008/3008D2 GCP Bidirectional Applications with Remote Unit, Multiple DAXing, One Track, Case Wiring	14-37
Figure 14-35:	Typical Model 3000/3000D2/3008/3008D2 GCP Bidirectional Applications with Remote Model 3000/3000D2 Unit, Multiple DAXing, One Track, Track Wiring	14-38
Figure 14-36:	Typical Model 3000/3000D2 GCP Bidirectional Advanced Preempt Timer Application, One Track, Case Wiring.....	14-39
Figure 14-37:	Typical Model 3000/3000D2 GCP Bidirectional DAX-UAX Interconnect Advanced Preempt Timer Application, One Track, Case Wiring	14-40
Figure 14-38:	Typical Model 3000/3000D2 GCP Bidirectional Switch to Motion Sensor Application, One Track, Case Wiring.....	14-41
Figure 14-39:	Typical Model 3000/3000D2 GCP Bidirectional DAX-UAX Interconnect Switch to Motion Sensor Application, One Track, Case Wiring	14-42
Figure 14-40:	Steady Energy DC Track Circuit with 60 or 100 Hz Cab Signal	14-43
Figure 14-41:	Mounting Dimensions, Model 3000, 3000ND, 3000ND2, and 3008 GCPs	14-44
Figure 14-42:	Mounting Dimensions, Model 3000D2 and 3008D2 GCPs.....	14-45
Figure 14-43:	Mounting Dimensions, Model 3000D2L GCP	14-46
Figure 14-44:	Model 3000 GCP Module Selection Chart.....	14-47
Figure 14-45:	Model 3000D2 GCP Module Selection Chart	14-48
Figure 14-46:	Model 3000ND GCP Module Selection Chart.....	14-49
Figure 14-47:	Model 3000ND2 GCP Module Selection Chart.....	14-50
Figure 14-48:	Model 3008 GCP Module Selection Chart.....	14-51
Figure 14-49:	Model 3008D2 GCP Module Selection Chart	14-52
Figure 15-1:	Recommended Surge Suppression Wiring for Model 3000/3000D2 GCP	15-2
Figure 15-2:	Typical Model 3000 GCP Surge Protection, Unidirectional Application With DC Island Track Circuit, One Track, Six Wire Hookup (Also Applies To Bidirectional Installations) 15-3	
Figure 15-3:	Typical Model 3000/3000D2 Surge Protection, DAX-UAX Interconnections, Line Wire or Underground Wire.....	15-4

List of Tables

Table 1-1:	Model 3000 GCP Basic Operating Parameters	1-1
Table 3-1:	Approach Length and Frequency Cross Reference List.....	3-1
Table 3-2:	Minimum Bidirectional Approach Length Vs. Frequency	3-9
Table 3-3:	Minimum Unidirectional Approach Length Vs. Frequency.....	3-10
Table 3-4:	Minimum Distance (Ft.) Between Termination Shunts When Repeating GCP Operating Frequencies	3-14
Table 4-1:	Model 3000 GCP Frequencies.....	4-2
Table 5-1:	Suggested Minimum Approach Distances with Narrow-band Shunt Termination, Unidirectional and Bidirectional Installations	5-1
Table 6-1:	Bypassing Insulated Joints	6-2
Table 6-2:	Minimum Distance to Insulated Joints When Coupled With 62785-F Tunable Insulated Joint Bypass Couplers	6-3
Table 7-1:	Transmit Lead Lengths	7-1
Table 7-2:	Minimum Bidirectional Approach Length Vs. Frequency	7-3
Table 7-3:	Minimum Unidirectional Approach Length Vs. Frequency.....	7-3
Table 12-1:	Auxiliary Equipment Index	12-1
Table 12-2:	Transfer Time Interval Selection	12-4
Table 12-3:	Automatic Transfer Timer Unit Controls and Indicators.....	12-5
Table 12-4:	Automatic Transfer Timer Unit Specifications.....	12-5
Table 12-5:	Automatic Transfer Timer Unit Terminal Connections.....	12-6
Table 12-6:	Data Recorder Interface Assembly Connector J1 Pin Assignments	12-12
Table 12-7:	Data Recorder Interface Assembly Specifications.....	12-12
Table 12-8:	3000 GCP Slaving Uni, 80065 Specifications.....	12-14
Table 12-9:	MS/GCP to Network Interface Plug Assembly Specifications	12-15
Table 12-10:	Approach Distance Selection Strapping	12-19
Table 12-11:	Bidirectional Simulation Coupler Specifications.....	12-19
Table 12-12:	Dimension Data for MS/GCP Termination Shunt Burial Kit, A62776	12-22
Table 12-13:	Data Recorder Interface Assembly Specifications.....	12-28
Table 12-14:	4-input Vital AND Gate, 91082.....	12-30
Table 12-15:	Battery Chokes, 62648 and 8A065, Specifications.....	12-33
Table 12-16:	Battery Choke, 6A342 Specifications.....	12-35
Table 12-17:	60 Hz AC Code Isolation Unit, 8A466-3 Specifications	12-37
Table 12-18:	100 Hz AC Code Isolation Unit, 8A471-100 Specifications	12-37
Table 12-19:	180 Hz AC Code Isolation Unit, 8A471-100 & -180 Specifications	12-39
Table 12-20:	Minimum Distance to Insulated Joints When Coupled With 62785-F Tunable Insulated Joint Bypass Couplers	12-40
Table 12-21:	Tunable Insulated Joint Bypass (IJB) Coupler, 62785-f Specifications	12-42
Table 12-22:	Narrow-band Shunt, 62775-f Available Frequencies (Hz)	12-43
Table 12-23:	Narrow-band Shunt, 62775-f Specifications	12-43
Table 12-24:	Narrow-band Shunt, 62780-f Available Frequencies (Hz)	12-43
Table 12-25:	Narrow-band Shunt, 62780-f Specifications	12-44
Table 12-26:	Adjustable Inductor Assembly Terminal Connections	12-45
Table 12-27:	Simulated Track Inductor, 8V617 Specifications	12-46
Table 12-28:	Multifrequency Narrow-band Shunt (62775-XXXX) Frequency Selection Jumpers ...	12-47
Table 12-29:	Multifrequency Narrow-band Shunt, 62775-XXXX Specifications	12-47
Table 12-30:	Multifrequency Narrow-band Shunt (62780-XXXX) Frequency Selection Jumpers ...	12-48
Table 12-31:	Multifrequency Narrow-band Shunt, 62780-XXXX Specifications	12-49
Table 12-32:	Simulated Track Inductor Part Number Listing	12-50
Table 12-33:	Simulated Track Inductor, 8V617 Specifications	12-50
Table 12-34:	Simulated Track Inductor, 8V617, Mounting Terminals.....	12-51
Table 12-35:	Wideband Shunt, 8A076 Specifications.....	12-52
Table 12-36:	80026-XX Surge Panel Applications.....	12-53
Table 12-37:	Surge Panel / Figure Number Cross Reference Chart	12-54

Table 13-1:	Programming Step Index	13-4
Table 13-2:	Programming Changes Requiring System Recalibration	13-5
Table 13-3:	Set to Default	13-29
Table 13-4:	Application Programming Procedures	13-29
Table 13-5:	Password Programming Procedures	13-32
Table 13-6:	Data Recorder Programming	13-33
Table 13-7:	External PC or Printer Programming	13-34
Table 13-8:	Date and Time Programming	13-34
Table 13-9:	Extended Application Programming.....	13-35
Table 14-1:	Table of Application Drawings, Mounting Dimensions, and Module Selection Charts .	14-1

This page intentionally left blank

SECTION 1 – INTRODUCTION

1.1 GENERAL

The Model 3000 Grade Crossing Predictor (Model 3000 GCP) is available in several hardware configurations (see Table 1-1) which provide single system operation for controlling one track circuit, double system operation for controlling two track circuits, and downstream adjacent crossing (DAX) capability for up to eight DAX circuits.

Automatic transfer systems (Models 3000D2, 3008D2, and 3000ND2) are also available and consist of two identical module sets plus a transfer module. One module set serves as the primary system while the other functions as the backup. In the event of a failure of one system, control is automatically switched to the other. The Model 3000D2 and 3008D2 module sets are housed in dual-bay, vertically-stacked cases designed for wall, shelf, or standard 23-inch rack mounting. The Model 3000ND2 is housed in a single-bay case.

Plug-in printed circuit modules are interchangeable between the various 3000 GCP configurations with the exception of Processor Module, 80044, and Transfer Timer Module, 80037, (3008D2 only) which are used exclusively in the 3008 and 3008D2 GCPs. Also, each 3000 GCP configuration is equipped with a control interface assembly which serves as the interface between the detachable Keyboard/Display Control Unit, 80019, and the host 3000 GCP data bus. Control Interface Assembly, 80154, is used in the Model 3000ND2 only while all other 3000 GCP models use Control Interface Assembly, 80020.

**Table 1-1:
Model 3000 GCP Basic Operating Parameters**

MODEL	ONE-TRACK OPERATION	TWO-TRACK OPERATION	DAX CAPABILITY	INTERNAL AUTOMATIC TRANSFER
3000	Yes	Yes	1 To 4	No
3000D2	Yes	Yes	1 To 4	Yes
3008	Yes	No	1 To 8	No
3008D2	Yes	No	1 To 8	Yes
3000ND	Yes	No	None	No
3000ND2	Yes	No	None	Yes

1.2 SYSTEM SPECIFICATIONS

ELECTRICAL DATA

Input Power	
• Voltage	9.0 to 16.5 VDC, 12 VDC nominal
• Current	
Single-track system	1.25 amperes
Two-track system	2.0 amperes
Optional modules	Up to 0.5 ampere each
Maximum current	4 amperes
Transceiver Output Current	Up to 500 mA (maximum); varies with frequency
Relay Drive Outputs	400- to 1,000-ohm load
Surge Protection	Built-in surge protection for track and battery connections. Requires only primary arresters and equalizers

PROGRAMMING DATA

Program Selection	Keystroke entry via keyboard/display; program is displayed by LCD readout
Diagnostics And Monitoring	Accomplished via two-line, 16-character, alphanumeric, liquid crystal display. The following are displayed: <ul style="list-style-type: none"> • Diagnostic information • Application programming • Train move data • Internal voltages

FREQUENCY DATA

Frequencies Available	86, 114, 156, 211, 285, 348, 430, 525, 645, 790, and 970 Hz (Frequencies can also be programmed between 45 and 999 Hz in 1-Hz increments.)
Frequency Stability	±0.01 percent
Island Frequencies Available (80011)	4.0, 4.9, 5.9, 7.1, 8.3, 10.0, 11.5, 13.2, 15.2, 17.5, or 20.2 kHz (Frequencies are fixed and are determined by individual 80011 modules.) (80211 IPI has frequencies programmable through the use of jumpers on the board. The additional frequencies available are: 2.14, 2.63, and 3.24 kHz).

CIRCUIT LENGTH DATA

Island Circuit Length	Determined by island track wire connection and range from 120 feet (minimum) to 300 feet (maximum)
Approach Track Circuit Length	Determined by type approach (Unidirectional or Bidirectional), frequency, and ballast conditions and range from 400 feet (minimum) to 7000 feet (maximum) (see Figure 3-7 and Figure 3-8)

PHYSICAL DATA – GENERAL

Mounting Options	The Model 3000 GCP can be wall, rack, or shelf mounted. All track, power, and slaving connections use standard AAR terminals.
Temperature Range	-40 F to +158 F (-40 C to 70 C)

PHYSICAL DATA – DIMENSIONS

Model 3000 GCP (single-bay case) (Figure 14-28)	23 inches wide (58.4 centimeters) 11.34 inches deep (28.8 centimeters) 14.36 inches high (36.5 centimeters)
Model 3000D2 (automatic transfer, dual-bay case) (Figure 14-29)	23 inches wide (58.4 centimeters) 11.34 inches deep (28.8 centimeters) 24 inches high (60.9 centimeters)
Model 3000ND (single-bay case) (Figure 14-28)	23.00 inches wide (58.4 centimeters) 11.34 inches deep (28.8 centimeters) 14.36 inches high (36.5 centimeters)
Model 3000ND2 (automatic transfer, single-bay case) (Figure 14-28)	23.00 inches wide (58.4 centimeters) 11.34 inches deep (28.8 centimeters) 14.36 inches high (36.5 centimeters)
Model 3008 (single-bay case) (Figure 14-28)	23.00 inches wide (58.4 centimeters) 11.34 inches deep (28.8 centimeters) 14.36 inches high (36.5 centimeters)
Model 3008D2 (automatic transfer, dual-bay case) (Figure 14-29)	23 inches wide (58.4 centimeters) 11.34 inches deep (28.8 centimeters) 24 inches high (60.9 centimeters)

PHYSICAL DATA – WEIGHT

Model 3000 GCP (All Modules in Place)	32 pounds (14.5 kilograms) (approximate)
Model 3000D2 GCP (All Modules in Place)	43 pounds (19.5 kilograms)(approximate)
Model 3000ND GCP (All Modules in Place)	20 pounds (9.08 kilograms) (approximate)
Model 3000ND2 GCP (All Modules in Place)	30 pounds (13.6 kilograms) (approximate)
Model 3008 GCP (All Modules in Place)	32 pounds (14.5 kilograms) (approximate)
Model 3008D2 GCP (All Modules in Place)	43 pounds (19.5 kilograms) (approximate)

1.3 MODES OF OPERATION

The 3000 GCP can be applied in two modes of operation which include (1) grade crossing predictor and (2) motion sensor. The 3000 GCP senses train movement inside the crossing approach and determines if movement is toward or away from the crossing. The unit also senses if a train has stopped in the approach or, through use of an island circuit, if the island is occupied.

When programmed as a grade crossing predictor, the 3000 GCP is designed to activate the warning system based on warning time setting. Therefore, if a constant-speed train is approaching the crossing at maximum speed or less, the warning time will remain constant, resulting in a significant reduction of unnecessary warning system operation. Grade crossing predictors are generally used where highway crossing traffic is dense, where switching occurs, or where DAXing is required. They are also less

sensitive to instantaneous distance voltage (EZ) changes and, therefore, are beneficial in areas of high interference (on the tracks) or where turnouts (switches) exist in the approach.

When programmed for motion sensor operation, the 3000 GCP is designed to activate the crossing warning system at train speeds of 2 miles-per-hour at the crossing or slightly faster near the end of the approach. Since crossing approach distances are calculated to provide sufficient warning time for maximum speed trains, a train approaching at less than maximum speed results in the warning system operating for a longer period of time.

1.4 APPLICATION CONFIGURATIONS: BIDIRECTIONAL, UNIDIRECTIONAL, AND BIDIRECTIONAL SIMULATION

The 3000 GCP can be applied in a bidirectional, unidirectional, or bidirectional simulation configuration. In a bidirectional application, the GCP monitors train movement in both approaches to the crossing while in a unidirectional application, the GCP monitors a single approach to the street. Bidirectional simulation can be applied to unidirectional motion sensor and GCP installations to obtain the operating benefits of a bidirectional application; primarily, the ability to operate with reduced ballast resistance. For a description of bidirectional simulation, refer to paragraph 9.2.

1.5 UNIDIRECTIONAL OR BIDIRECTIONAL?

While bidirectional installations fit the majority of locations and can minimize the number of units required, unidirectional/bidirectional simulation installations are necessary in the following instances:

- Locations in cab signal or other track circuit territory where insulated joints cannot be bypassed with tuned couplers.
- Where necessary to provide insulated joint isolation so that frequencies can be reused in multiple crossing areas.

Designing bidirectional applications is simpler due to fewer restrictions from ballast and adjacent frequency shunt loading. Operationally, there is a single difference between the two modes of operation and this concerns closely following trains and standing cars in one approach. Both conditions can result in reduced warning times for a bidirectional unit while the unidirectional unit would be unaffected. Two different GCP-to-motion sensor conversion features in the 3000 GCP (see paragraph 13.3) serve to minimize effects of these conditions. In addition, operating rules require the train crew to verify crossing warning conditions before entering the street in the case of standing cars.

SECTION 2 – COMPATIBILITY WITH VARIOUS TYPE OF TRACK CIRCUITS

The 3000 GCP is generally compatible with the following types of track circuits providing good track shunting occurs and the application guidelines are adhered to.

- Steady energy DC track circuits
- With the following DC coded track circuits:
 - Siemens GEO
 - Electro Code
 - Single polarity DC code (the transmit and receive pulses are of the same polarity.)
 - GRS Trakode only with TD relays used at each code location
 - Micro Code III
- 60 Hz, style C track circuit (if rusty rail, motion sensor only)
- 100 Hz steady cab (non-coded)
- Most types of audio frequency overlay with proper frequency selection

Contact Siemens Application Engineering for assistance in applying GCP's with the following:

- Dual polarity coded track circuits
- 60 Hz and 100 Hz coded track circuits
- Rusty Rail – In general, the application of motion equipment should be avoided if rusty rail conditions exist. Should rusty rail conditions be encountered at any existing installation, the 3000 GCP must be programmed to operate as a motion sensor, using enhanced detection if available. Consider using a DC exciter circuit (80049).

This page intentionally left blank

SECTION 3 – GCP FREQUENCY SELECTION

3.1 GENERAL

In general, adherence to the following frequency selection criteria yields optimum 3000 GCP performance over a range of track conditions including low ballast, adjacent streets, bypassed insulated joints, termination shunts, etc.

**Table 3-1:
Approach Length and Frequency Cross Reference List**

APPROACH LENGTH FT.)	FREQUENCY (HZ)
400 To 2,000	285 And Higher
2,000 To 3,000	156 To 211
3,000 And Above	156 And Lower

NOTE

Other conditions such as coded track may further modify the above selections.

Additional factors must be considered when selecting an operating frequency. These are discussed in the following paragraphs.

3.2 DC CODE (RELAY)

Frequencies of 86 Hz and higher can be used for installations in DC coded track territory. When using frequencies of 211 Hz and lower, maximum transmit level should also be used. Refer to Section 8, Track Circuit Isolation, for applicable isolation and filter requirements.

3.3 STEADY ENERGY 100 HZ

For installations in 100 Hz (non-coded) cab signal circuits, select frequencies of 156 Hz or higher and use maximum transmit level. Refer to Section 8 for applicable isolation and filter requirements.

3.4 STYLE C TRACK CIRCUITS

Model 3000 GCP applications are generally not recommended where heavy rust conditions exist on the rails. Grade crossing predictors programmed for motion sensor operation should be considered for style C applications, keeping in mind that a good shunt is necessary for optimum operation. In most cases, application of systems over style C track circuits offers improved shunting operation when compared with operation without the AC circuit. These installations normally require maximum motion sensor transmit level, frequencies of 285 Hz and higher, plus additional isolation units. Contact Siemens Application Engineering for assistance.

3.5 60 AND 100 HZ AC CODED TRACK OR CODED CAB SIGNAL CIRCUITS

Application of 3000 GCPs in coded AC or cab circuits should use frequencies of 156 Hz (60 Hz cab) or 211 Hz (100 Hz cab) or higher with maximum transmit current. Refer to Section 8 for additional requirements.

3.6 LOADING EFFECT OF NARROW-BAND SHUNTS (62775-F AND 62780-F) AND TERMINATIONS

Siemens 3000 GCP frequencies are mutually compatible. However, when crossings are sufficiently close that GCP approaches overlap, narrow-band shunts (NBS's) must be used in place of wideband shunt terminations. Two series of NBS's are currently available and include the 62775-f and 62780-f versions. The 62775-f NBS is the primary termination shunt for both bidirectional and unidirectional applications.

WARNING

WARNING

THE 62775-F NBS'S MAY NOT BE USED IF APPROACHES OVERLAP MODEL 300 OR MODEL 400 GCP APPROACHES. USE THE 62780-F SHUNT IN THESE APPROACHES.

While NBS's do not terminate other GCP frequencies, they do produce a loading effect upon those frequencies. The severity of the loading effect is directly related to frequency proximity, with adjacent channels being affected the most. A zone, which is centered at the GCP track wire feed points (at the crossing), exists in which adjacent channel frequency NBS's should not be located if optimum, trouble-free GCP operation is to be attained over the expected range of ballast resistance variations. The adjacent channel charts shown in Table 3-1 define the zones for the 62775-f and 62780-f NBS's for all 3000 GCP standard Siemens frequencies based on bidirectional applications.

Referring to Figure 3-1 through Figure 3-4, the 62775-f NBS can be used anywhere outside of the zone indicated by both the crosshatched and solid black areas while the 62780-f NBS can be used anywhere outside of the zone indicated by the solid black area only. Although the 62780-f NBS has less loading effect on other GCP frequencies, it does not perform as well as the 62775-f NBS under low ballast conditions. Therefore, use the 62780-f NBS from Figure 3-1 through Figure 3-4 only where necessary for proper frequency layout in complex installations (multiple streets overlapping).

In Figure 3-1 through Figure 3-4, bidirectional approach distances are indicated along the left side of each chart while the vertical line at 0 (zero) represents the crossing feed points. To determine the distance on either side of the crossing feed point which an adjacent channel NBS should not be used, refer to the applicable chart for the crossing frequency under consideration.

Next, determine the portion of the approach that falls within the crosshatched (62775-f) or solid black (62775-f or 62780-f) areas.

NOTE

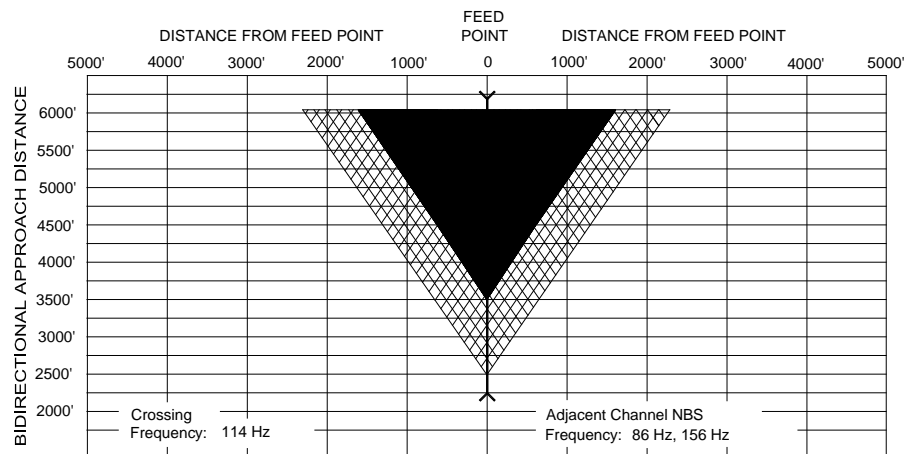
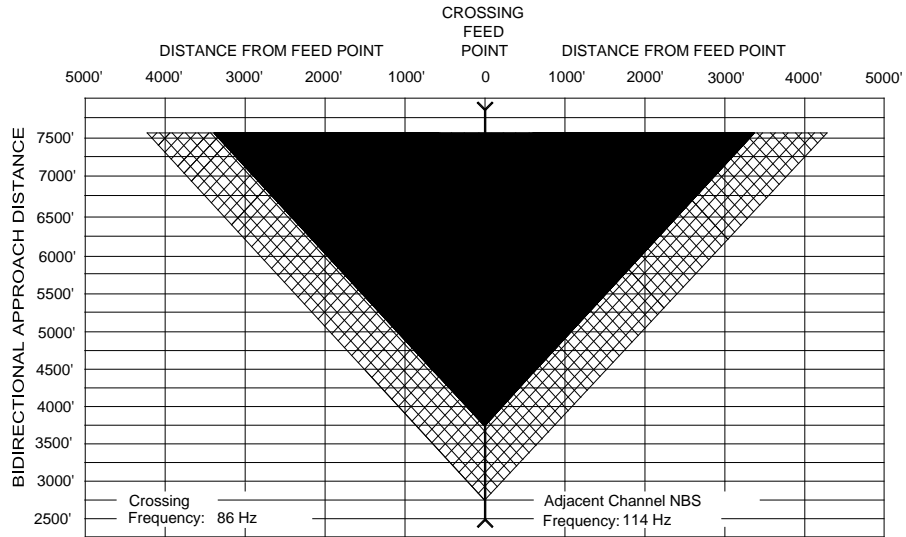
NOTE

At insulated joints, if a narrow band shunt is used with a simulated track load (dummy load) of 1,500 feet or greater, it must be considered as one frequency or channel lower for loading effects; e.g., if 285, then treat as 211.

KEY FOR FIGURE 3-1

■ DO NOT USE ADJACENT CHANNEL NBS
62775-f OR 62780-f IN THIS ZONE.

▨ DO NOT USE ADJACENT CHANNEL NBS
62775-f IN THIS ZONE.



FILE: SHCH1

**Figure 3-1:
Adjacent Channel Frequency Narrow-band Shunt
(86 & 114 Hz) Placement Charts, Bidirectional Applications**

GCP FREQUENCY SELECTION

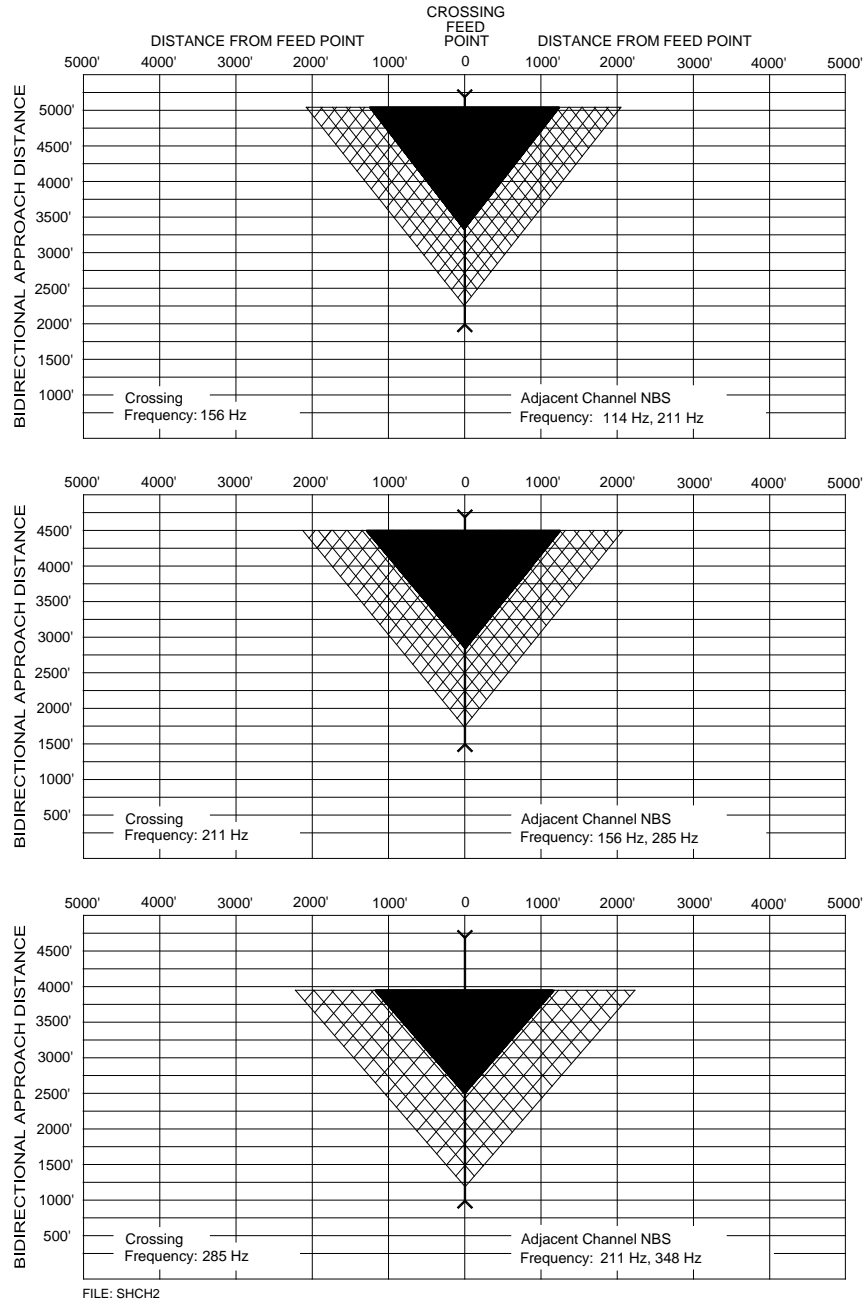
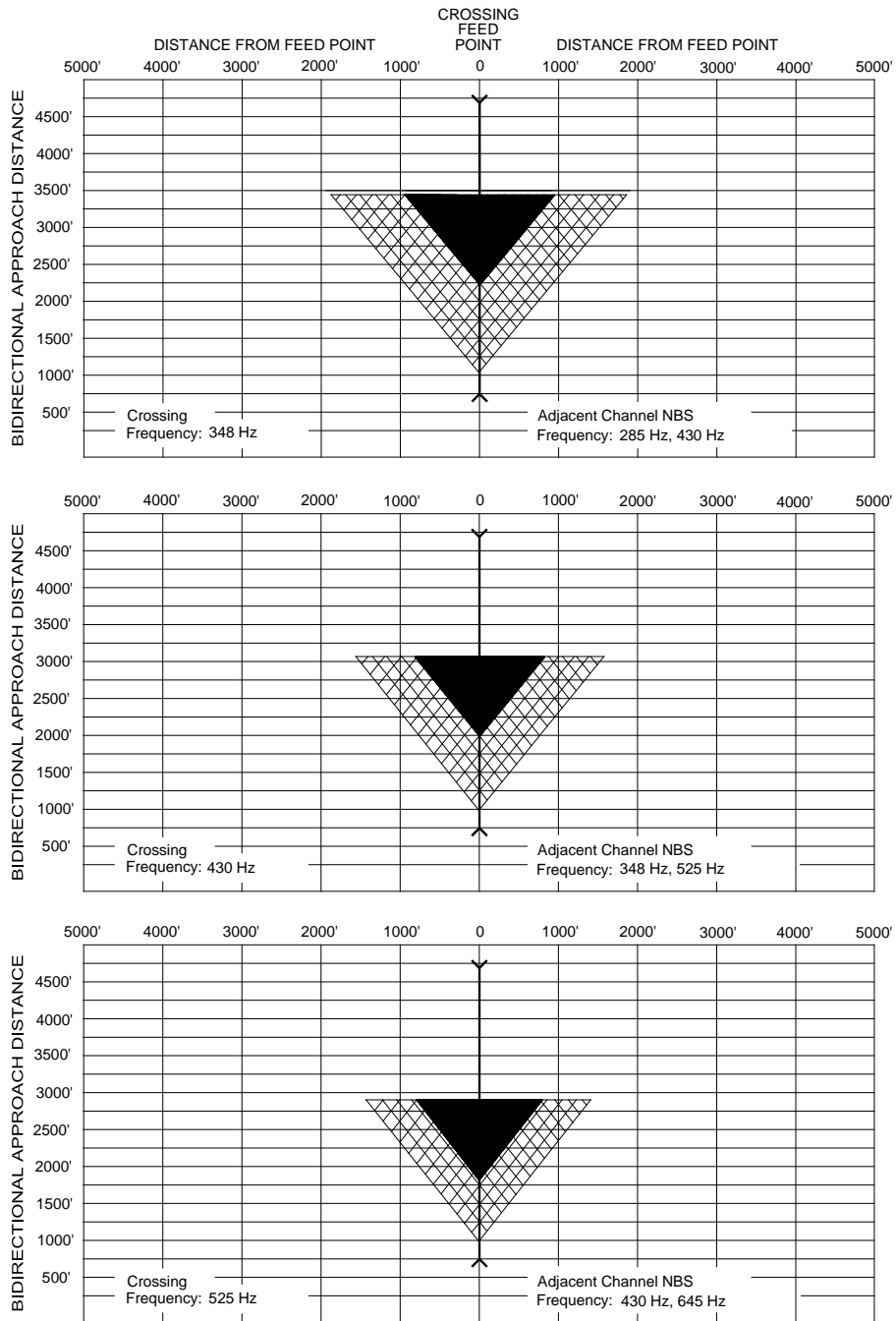


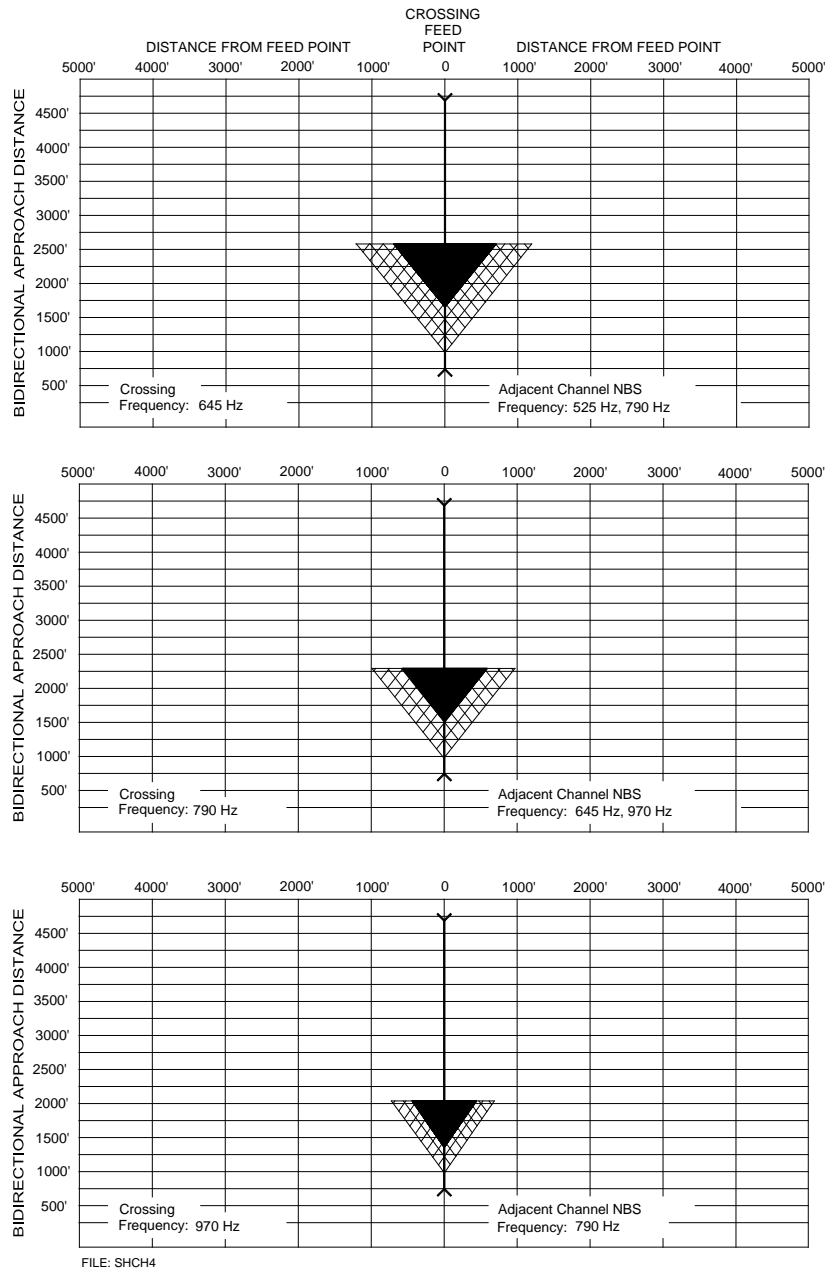
Figure 3-2:
Adjacent Channel Frequency Narrow-band Shunt
(156, 211, & 285 Hz) Placement Charts, Bidirectional Applications



FILE: SHCH3

**Figure 3-3:
Adjacent Channel Frequency Narrow-band Shunt
(348, 430, & 525 Hz) Placement Charts, Bidirectional Applications**

GCP FREQUENCY SELECTION



**Figure 3-4:
Adjacent Channel Frequency Narrow-band Shunt
(645, 790, & 970 Hz) Placement Charts, Bidirectional Applications**

For example, with a crossing frequency of 114 Hz and approach lengths of 4,500 feet (see Figure 3-1), NBS's (62775-f) of 86 Hz or 156 Hz should not be located within approximately 1,350 feet of the 114 Hz feed points while 62780-f NBS's of the same frequency should not be located within approximately 700 feet of the 114 Hz feed points.

While charts are not included for unidirectional applications, the basic guideline to follow is to avoid overlap of one adjacent channel. For example, when using 86 Hz, the nearest frequency would be 156 Hz. If the one channel separation NBS falls in the outer 50 percent of the approach, use a 62775-f NBS. If it falls between the crossing and 50 percent of the approach, use a 62780-f NBS.

3.7 OTHER AC SIGNALS ON THE TRACK

A survey should be made to determine what audio frequencies currently exist, since they can affect 3000 GCP frequency selection. Siemens equipment is compatible with most motion sensing and constant warning time units supplied by other manufacturers, provided frequency separation and compatibility are maintained.

Since other manufacturers' equipment operates at frequencies other than those supplied by Siemens, do not select a Siemens frequency if any existing frequencies are within 15 percent of the Siemens frequency. For example, 15 percent of Siemens frequency 156 Hz is 24 Hz. Therefore, do not select 156 Hz if any existing frequency is in the range of 156 ± 24 Hz, i.e. between 132 and 180 Hz. However, if the track circuits established by equipment of other manufacturers are terminated by NBS's, the restrictions stipulated in paragraph 3.6 must also be observed.

When using PSO II,, refer to Figure 3-5 below for 3000 GCP frequency compatibility.

3.8 APPROACH LENGTH CALCULATION

The length of the approach for a remote unit or a unit without an island circuit is defined as the distance from the GCP track feed wires to the termination shunt connections. The length of the approach for a unit with an island circuit is defined as the distance from the edge of the street nearest the receiver feed wires to the termination shunt connections. In both instances, approach length calculation is based upon three factors:

1. Maximum train speed encountered,
2. Desired crossing signal operating time (or traffic signal preemption time when used), and
3. GCP system response time, which is 4 seconds

To determine the maximum train speed, use the highest train speed expected in the GCP approach, calculated in feet per second. To calculate train speed in feet per second, perform the following:

- Train speed (MPH) x 1.47 = speed in feet per second
- Example: 60 MPH x 1.47 = 88 feet per second.

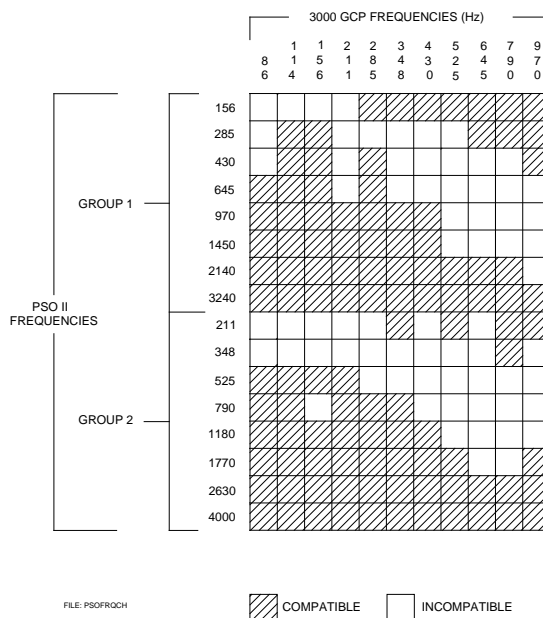


Figure 3-5:
PSO II Vs. 3000 GCP Frequency Compatibility

To calculate the approach length of the GCP circuit (the distance from the GCP track wires (or from the edge of the street) to the termination shunt), perform the following:

- (Warning time desired + GCP response time) x maximum train speed (feet per second) = GCP approach distance
 - Example: (30 seconds + 4 seconds) x 88 feet per second = approach distance
 - $(30 + 4) \times 88 = 2,992$ feet

NOTE

NOTE

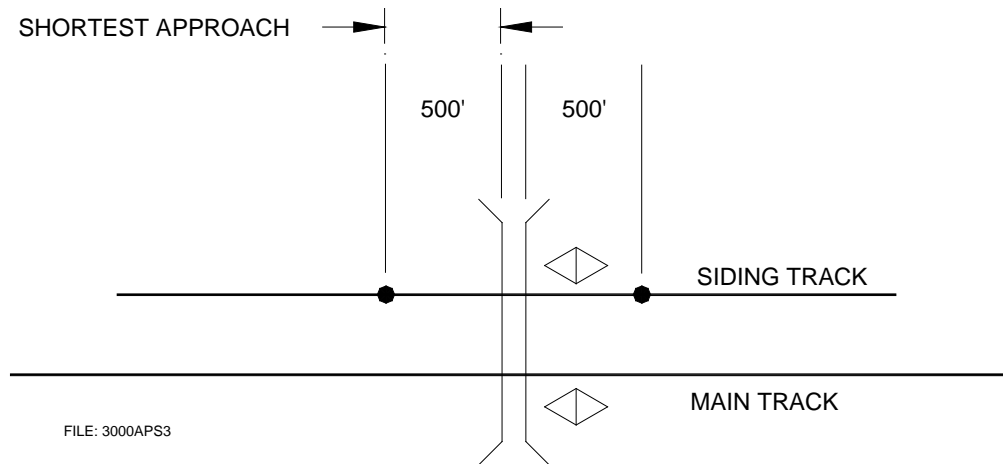
The approach length calculated in the example above represents the minimum approach distance only. Railroads may wish to factor in additional warning time to allow for angled crossings, multiple tracks, etc.

3.8.1 Preempting Traffic Signals

When preempting traffic signals for the same crossing as the GCP, the approach distance must be based on the preempt warning time selected, not on the crossing warning time. The system response time must also be added to the preempt warning time. The GCP must be programmed for preempting, after an appropriate DAX module (80016) has been installed (see Section 10, 3000 GCP DAX Applications).

3.9 MINIMUM APPROACH LENGTH VERSUS FREQUENCY FOR MODEL 3000 GCP'S CONTROLLING TWO-TRACK CIRCUITS

The shortest distance at which a low-frequency Model 3000 GCP will provide reliable operation is generally a function of the GCP operating frequency plus the gauge and length of the copper transmit wires connecting the GCP to the rails. When a low-frequency 3000 GCP is controlling both a long main track circuit and a shorter siding track circuit as illustrated below, the shortest bidirectional approach distance permissible at the installation is indicated in Table 3-2. The minimum approach distances given are based upon the GCP operating frequency versus the transmit wire application, size, and length. For unidirectional installations, the length of the shortest approach is 70 percent of the distance given for a bidirectional installation as indicated in Table 3-3, but not less than 400 feet.



**Figure 3-6:
Minimum Approach Lengths**

For example, Tables 3-2 and 3-3 indicate that for the lower GCP operating frequencies, the shortest approach distance is obtained by using a six-wire connection to the rails (see Section 7.3). The next shortest distance can be obtained by doubling each transmit wire (two number 6 AWG copper wires in parallel for each transmit wire) or by using single number 4 AWG copper wires. The remaining minimum approach distances may be obtained from the tables by noting the transmit wire lengths.

Installations containing an approach that does not meet the minimum distance restrictions specified in Tables 3-2 or 3-3 will frequently exhibit a 20- to 30-second overring condition at the crossing. This is caused by a T1 or T2 gain check error which is indicated by a 9111 or 9112 error message generated by the GCP.

**Table 3-2:
Minimum Bidirectional Approach Length Vs. Frequency**

3000 GCP TRANSMIT FREQUENCY (HZ)	MINIMUM APPROACH LENGTH (IN FEET)				
	TRANSMIT WIRE LENGTH (NO. 6 COPPER)				
	SIX-WIRE CONNECTION (SEE NOTE)	100 FEET DOUBLE (OR 1#4)	100 FEET	150 FEET	200 FEET
86	1000	1000	1350	----	----
114	750	800	1150	----	----
156	600	700	1000	1150	1350
211	475	600	850	1000	1150
285	400	550	750	850	1000
348	400	500	700	800	850
430	400	500	650	750	750
525	400	500	600	700	700
645	400	500	550	650	650
790	400	500	500	600	600
970	400	500	475	550	550

NOTE

When an island frequency is transmitted on the same leads as the GCP operating frequency in a six-wire hookup, maximum transmit wire length is 250 feet.

**Table 3-3:
Minimum Unidirectional Approach Length Vs. Frequency**

3000 GCP TRANSMIT FREQUENCY (HZ)	MINIMUM APPROACH LENGTH (IN FEET)				
	TRANSMIT WIRE LENGTH (NO. 6 COPPER)				
	SIX-WIRE CONNECTION (SEE NOTE)	100 FEET DOUBLE (OR 1#4)	100 FEET	150 FEET	200 FEET
86	700	700	945	----	----
114	525	560	805	----	----
156	420	490	700	805	945
211	400	420	595	700	805
285	400	400	525	595	700
348	400	400	490	560	595
430	400	400	455	525	525
525	400	400	420	490	490
645	400	400	400	455	455
790	400	400	400	420	420
970	400	400	400	400	400

NOTE

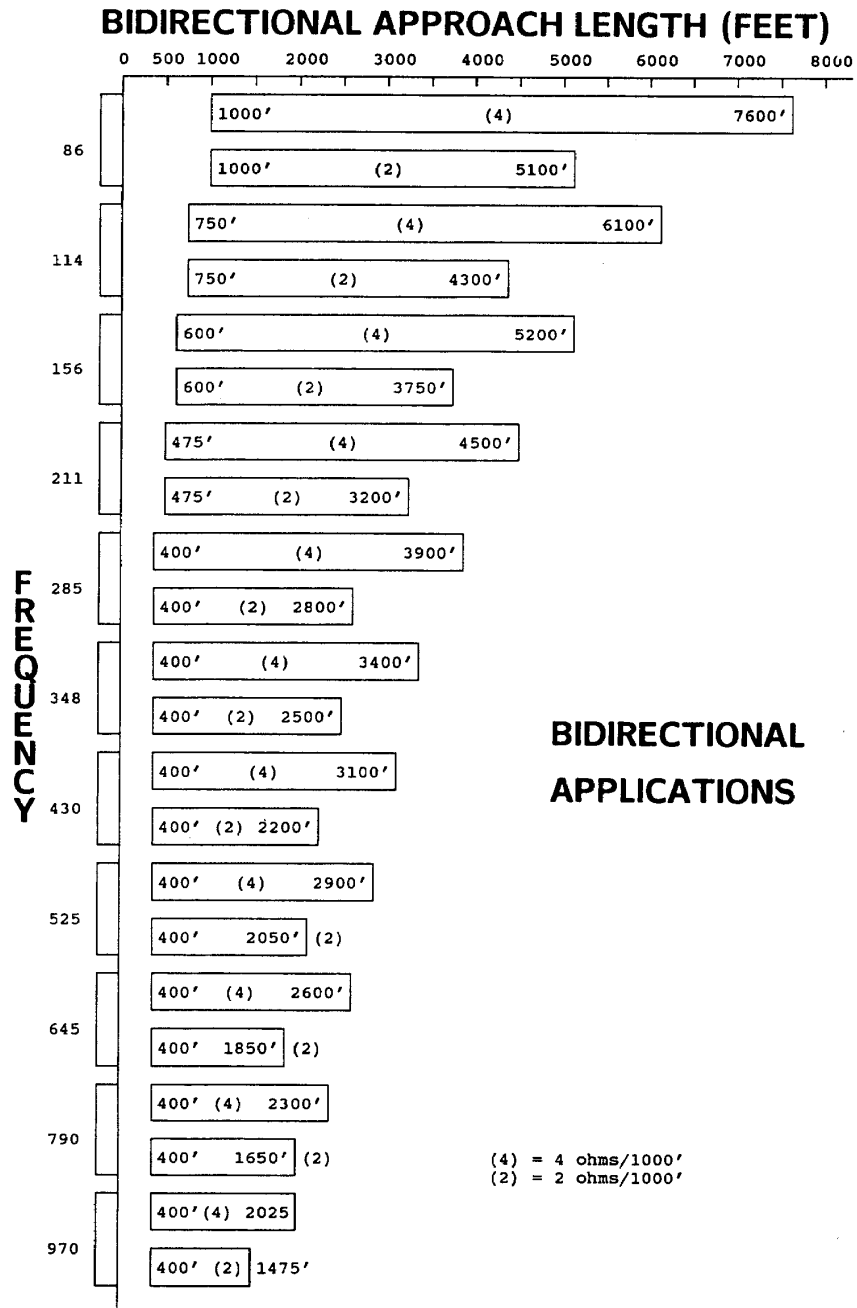
NOTE
When an island frequency is transmitted on the same leads as the GCP operating frequency in a six-wire hookup, maximum transmit wire length is 250 feet.

3.10 BALLAST RESISTANCE VERSUS APPROACH LENGTH (BIDIRECTIONAL AND UNIDIRECTIONAL APPLICATIONS)

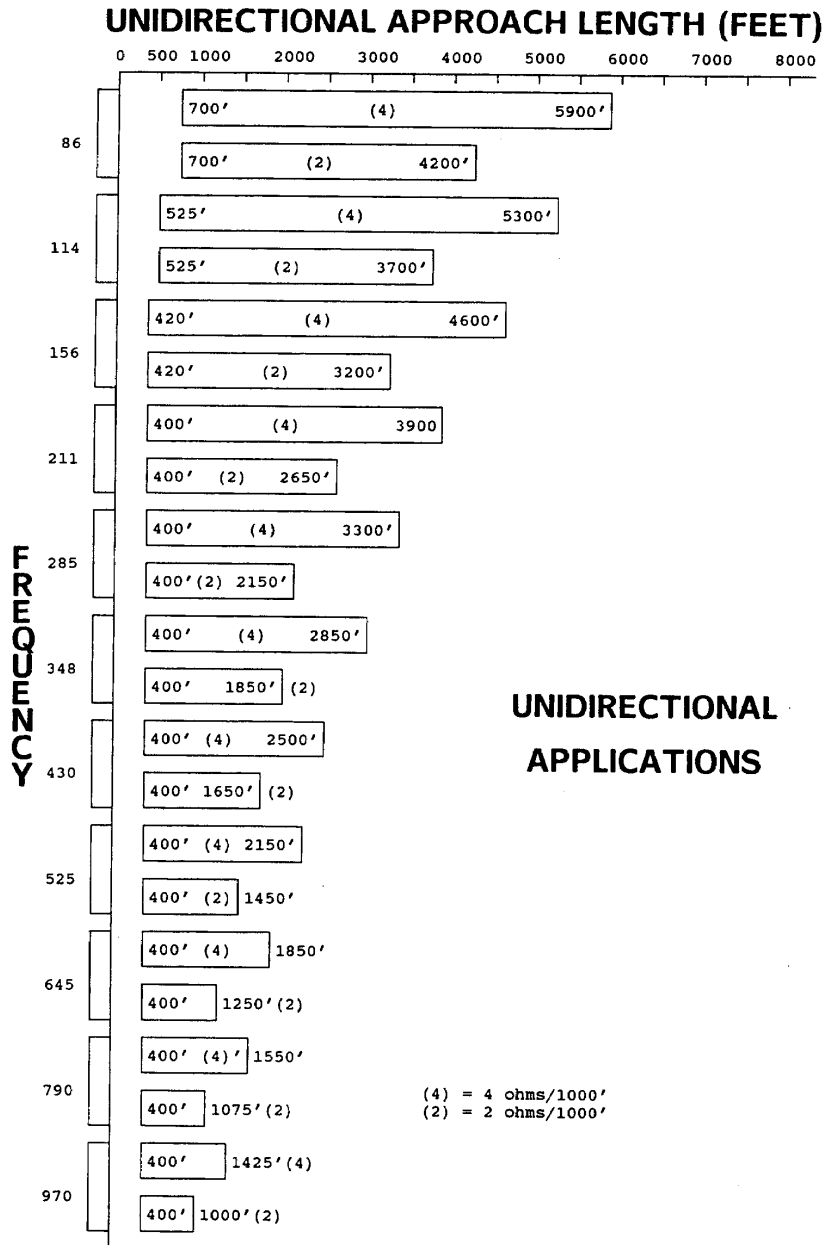
The charts in Figure 3-7 and Figure 3-8 indicate minimum and maximum approach lengths for each standard Siemens GCP frequency for ballast resistance of 2 and 4 ohms per 1,000 feet. In general, the frequency selected should be as low as possible, consistent with the rules discussed in paragraphs 3.1 through 3.7. Maximum operating distances for any given frequency are governed by ballast resistance conditions, increasing with higher ballast and decreasing with lower ballast. Minimum approach distances are determined by available system gain, resulting in shorter distances at higher frequencies. The minimum approach distance figures indicate the shortest approach distance over which a given frequency will operate (see paragraph 3.9).

NOTE

NOTE
Minimum approach lengths are based upon use of hard-wire or wideband shunts. Maximum approach lengths are based upon 2 or 4 ohms per 1,000 feet distributed ballast.



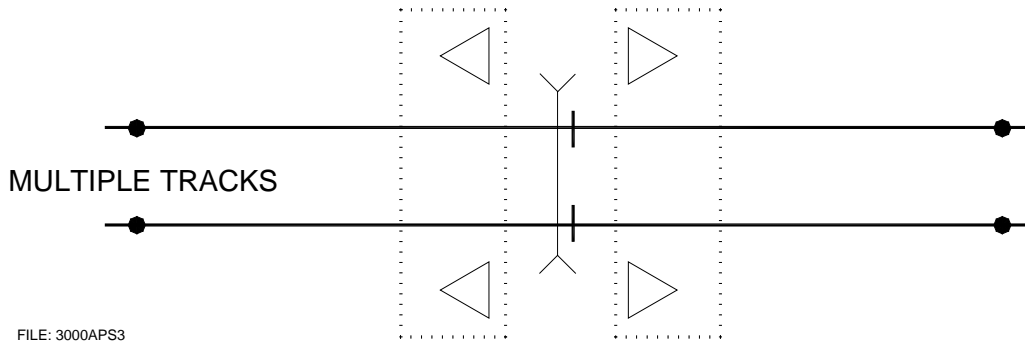
**Figure 3-7:
Ballast Resistance Versus Approach Length
By Frequency - Bidirectional Application**



**Figure 3-8:
Ballast Resistance Versus Approach Length
By Frequency - Unidirectional Application**

3.11 MULTIPLE TRACK CROSSINGS (SLAVING/NONSLAVING)

To conserve frequencies in a high crossing density area, the 3000 GCP can use the same frequency on all tracks at a multiple track crossing. To prevent frequency crosstalk, all GCPs must be synchronized through a master/slave operation provided via front panel terminals. Refer to the diagram below and to Figure 14-14 for wiring details. A maximum of eight units can be slaved to a single GCP.



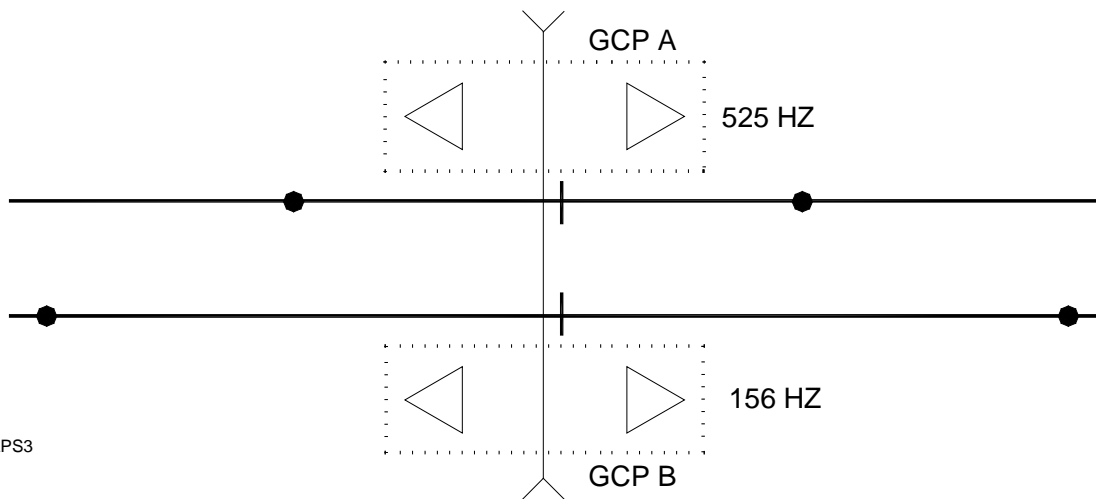
**Figure 3-9:
Master/Slave GCP Operation – Same Frequency**

In many instances, the approach distance required for different tracks varies in length. When selecting the GCP frequency, ensure that the selected frequency will operate over all approach distances found on the multiple tracks as described in paragraph 3.9.

NOTE

NOTE
When operating as a master unit, the 3000 GCP can control other 3000 GCP slave units only and no other type of equipment.

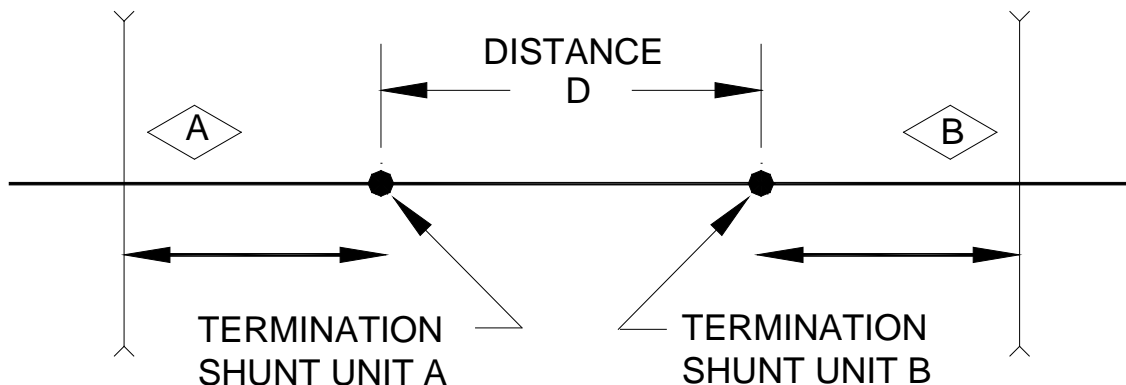
In multiple track locations (especially in certain double track areas where sufficient GCP frequencies are available), the GCPs are not required to be frequency slaved but can operate at different frequencies. This is especially true where a siding track has a considerably shorter approach distance than the main track. For example, in the diagram shown below, GCPs A and B can be configured to operate at two different frequencies.



**Figure 3-10:
Master/Slave GCP Operation – Different Frequencies**

3.12 REPEATING 3000 GCP OPERATING FREQUENCIES

In general, two 3000 GCPs should not be operated at the same frequency on a common track unless the units are separated by insulated joints. However, if repeating frequencies becomes necessary due to crossing densities, frequencies may be repeated provided the GCP approaches do not overlap and sufficient distance (D) exists between termination shunts (see Figure 3-11 and Table 3-4).



FILE: 3000APS3

**Figure 3-11:
Overlapping Approach Distances**

**Table 3-4:
Minimum Distance (Ft.) Between Termination
Shunts When Repeating GCP Operating Frequencies**

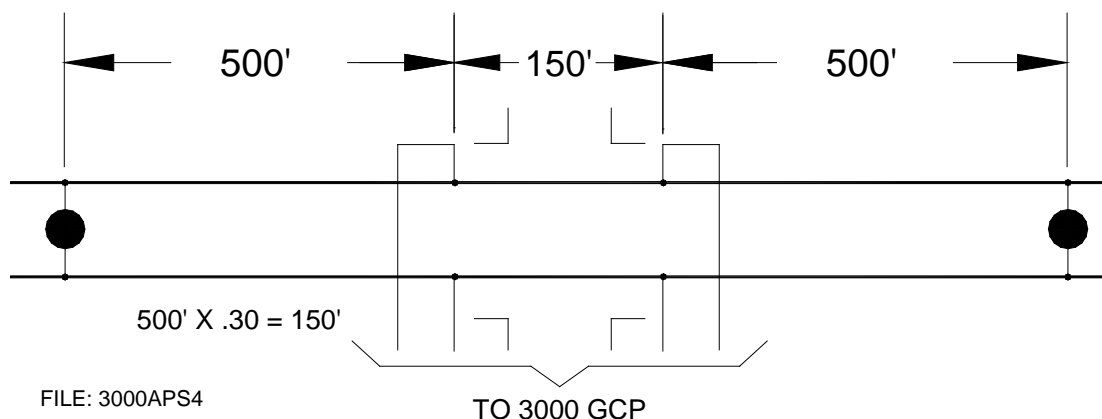
STANDARD 3000 GCP FREQUENCY (HZ)	DISTANCE (D) FOR NARROW-BAND SHUNTS 62775-F/62780-F	DISTANCE (D) FOR WIDEBAND SHUNTS 8A076A/8A077A
86	4,000	1,200
114	3,300	1,000
156	2,500	750
211	1,500	450
285	750	225
348	500	150
430	400	100
525	350	75
645	600	50
790	250	25
970	250	25

Distance (D) varies according to frequency and type of terminating shunt. In Table 3-4 above, the values indicated for distance (D) are the minimum allowable distances between shunts. Distances greater than those indicated are, of course, preferable, especially in areas with excellent ballast conditions.

SECTION 4 – ISLAND FREQUENCY SELECTION AND ISLAND LENGTH

4.1 GENERAL

The 3000 GCP uses an island module (80011-f/80211) to control the island circuit. The island module, which supplies a short modulated track circuit (SMTC), provides excellent cutoff and shunting characteristics under varying ballast conditions. Siemens recommends that the minimum length of an island track circuit should be 120 feet between track connections, or longer if required to ensure island circuit shunting for the operating car fleet and to comply with the operating practices of the railroad. To ensure proper GCP operation, the maximum island length (measured between the track wire connections on either side of the crossing) should be 300 feet and must not exceed 30 percent of the longest GCP approach. The 30 percent figure applies to approach circuits that are 1,000 feet or shorter.



**Figure 4-1:
Typical Island and Approaches**

NOTE

NOTE
In applications where poor shunting is a possibility (rusty rails, light cars, etc.), and enhanced island circuit shunting sensitivity is desirable, use the alternate island circuit shunting sensitivity adjustment procedure provided in Section 6I, System Calibration, of the 3000 GCP Instruction And Installation Manual. The procedure adjusts the shunting sensitivity to 0.12 ohm instead of the standard 0.06 ohm.

4.2 ISLAND MODULE, 80011-F/80211

The Intelligent Processor Island (IPI) Module is:

- Field programmable for frequency of operation and pickup delay
- Microprocessor-controlled
- Interchangeable with the earlier 80011 Island Module in all 3000/3008 GCP units

In operation, the IPI module:

- Accommodates an island circuit length of between 120 and 350 feet
- Interfaces with the rails via the AAR terminals on the front panels of the GCP
- Greatly enhances track occupancy operation in poor island track shunting environments where:
 - Contaminated rail or car wheels are prevalent
 - Long/light axle-load cars are encountered

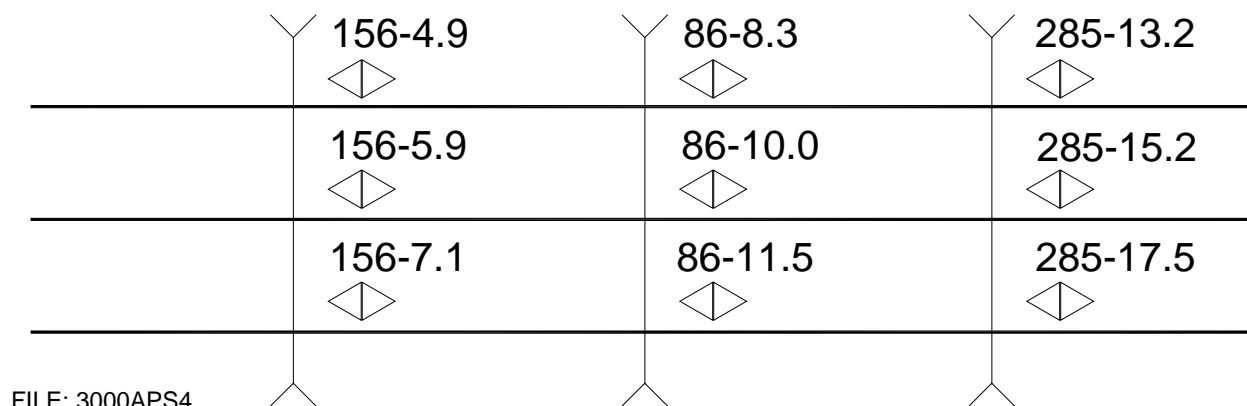
Refer to the Intelligent Processor Island (IPI) Instruction and Installation Manual (Siemens Document SIG-00-97-04) for further discussion of the IPI Module.

The island module consists of a modulated, high-frequency transceiver which is compatible with most track circuits, including DC and AC coded track. (80211 has 2.14 kHz, 2.63 kHz, and 3.24 kHz in addition to the frequencies listed below). Island circuit operating frequencies include:

**Table 4-1:
Model 3000 GCP Frequencies**

4.0 kHz	4.9 kHz	5.9 kHz	7.1 kHz	8.3 kHz	10.0 kHz
11.5 kHz	13.2 kHz	15.2 kHz	17.5 kHz	20.2 kHz	

Frequencies of 10.0 kHz and lower should be used when required island length is over 200 feet, or lumped ballast loading at the street is anticipated. At multiple track installations, use different frequencies for each island circuit. Island frequencies should not be repeated in the same track circuit within 3,000 feet or within 1,500 feet on adjacent tracks (unless separated by insulated joints). The following diagram illustrates a typical installation in which multiple high-frequency island circuits are used:



**Figure 4-2:
Multiple High-Frequency Island Circuits**

NOTE

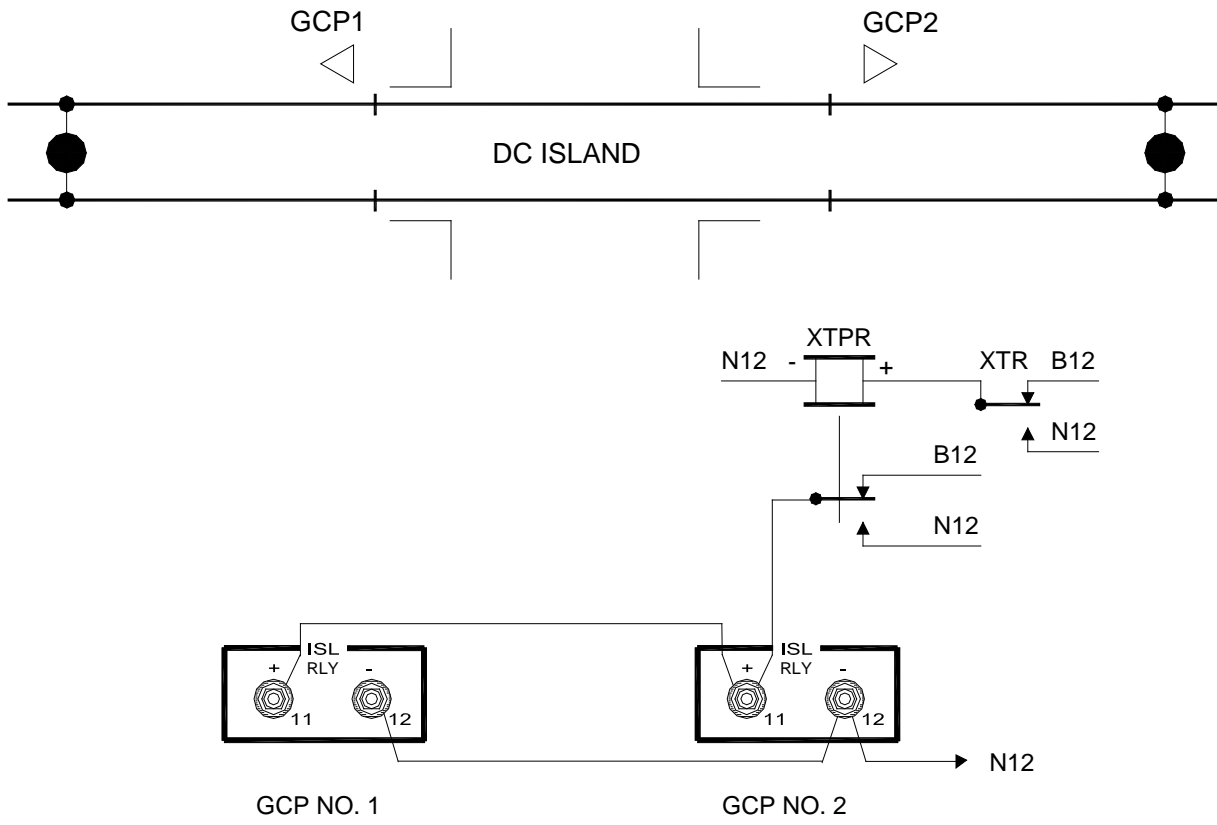
NOTE
In certain applications with adverse ballast conditions the IP track circuit may experience interference from islands with the same frequency at distances further than 5000 feet.

WARNING

WARNING
HIGH-FREQUENCY ISLAND MODULES (80011-F/80211) MUST BE A DIFFERENT FREQUENCY FOR EACH TRACK OF A MULTIPLE TRACK INSTALLATION.

4.3 DC ISLAND CIRCUIT

When a DC island circuit is used in place of island module 80011), battery B (+) must be applied to the island relay drive terminals of the two unidirectional GCPs through a front contact of the DC island repeater relay as shown in the diagram below. When the island is occupied, the relay back contact applies battery N (-) to the island relay drive terminals.



3000APS9

**Figure 4-3:
DC Track Circuit Island Relay Strapping**

This page intentionally left blank

SECTION 5 – TERMINATION SHUNTS

5.1 GENERAL

Termination shunts are always required for 3000 GCP installations and must be connected across the rails at sufficient distances from the feed point to provide full crossing signal operating time as described in Paragraph 3.8, Approach Length Calculation. The shunt can be (1) a Bond Strand when no other signals (AC or DC) are present on the rails, (2) a wideband shunt (8A076A or 8A077A) when used with steady energy DC track circuits only, or (3) narrow-band shunt (62775-f or 62780-f) when other AC signals or coded DC is present on the rails. Termination shunts should be located near the rails with leads as short as possible. Wideband and narrow-band shunts should be buried at least 18 inches below the surface, or MS/GCP Shunt Burial Kit, P/N A62776, should be used to protect the devices from physical damage and for ease of maintenance (see paragraph 12.19).

5.2 MINIMUM APPROACH DISTANCES, NARROW-BAND SHUNT TERMINATIONS



WARNING

WARNING

NARROW-BAND SHUNT (62775-F) SHOULD NOT BE USED ANYWHERE WITHIN A MODEL 300 OR MODEL 400 GCP APPROACH. USE OF NARROW-BAND SHUNT (62780-F) IS RECOMMENDED.

**Table 5-1:
Suggested Minimum Approach Distances with Narrow-band Shunt
Termination, Unidirectional and Bidirectional Installations**

UNIDIRECTIONAL INSTALLATION		BIDIRECTIONAL INSTALLATION	
FREQUENCY (HZ)	MINIMUM APPROACH DISTANCE (FT.)	FREQUENCY (HZ)	MINIMUM APPROACH DISTANCE (FT.)
86	3,000	86	2,000
114	2,500	114	2,000
156	2,000	156	1,500
211	1,500	211	1,500
285	1,000	285	1,000
348	1,000	348	850
430	800	430	750
525	600	525	700
645	600	645	650
790	420	790	600
970	400	970	550

The three types of termination shunts indicated in paragraph 5.0 above do not provide equally low terminating impedance to the 3000 GCP operating frequencies. The hard wire and wideband shunts present an effective short circuit to all audio frequencies when connected across the rails. A narrow-band shunt does not provide as low an impedance at the tuned frequency as the hard wire or wideband shunt. This characteristic affects the minimum approach distances that should be considered when narrow-band shunts are used.

When an NBS termination is used for a short approach, the GCP signal exhibits a tendency to 'bleed' past the NBS termination. This tendency is more pronounced where low frequencies, short approaches, or 62780-f shunts are used. Table 5-1 on the following page provides general guidelines for selecting standard Siemens GCP operating frequencies that minimize bleed-by associated with approach distance.

However, the frequency selected must also be sufficiently low to ensure reliable operation for the ballast resistance conditions encountered in the area. For this reason, it may occasionally be necessary to select a frequency that is a compromise between the two considerations. The 62775-f narrow-band shunt allows less bleed-by than does the 62780-f NBS and is, therefore, preferred, especially at lower (156 Hz and below) GCP frequencies.

5.3 TERMINATION SHUNTS AT INSULATED JOINTS

A pre-ring may occur in a very limited number of applications where a narrow-band termination shunt (without offset) is located at a set of insulated joints. To eliminate the problem, use Simulated Track Inductor, 8V617, (see paragraph 12.11) with a multifrequency narrow-band shunt or Adjustable Inductor, 8A398-6, (see paragraph 12.12) with a standard, single-frequency narrow-band shunt. The additional inductance should be set for 10 percent of the approach distance to ensure an EZ change which is greater than 10.

NOTE

NOTE

At insulated joints, if a narrow band shunt is used with a simulated track load (dummy load) of 1,500 feet or greater, it must be considered as one frequency or channel lower for loading effects; e.g., if 285, then treat as 211.

5.4 INSTALLATION OF NARROW-BAND TERMINATION SHUNTS IN EXISTING MS/GCP APPROACHES

Any time that a Siemens or other manufacturer's narrow-band termination shunt of a new crossing is installed and the location of the shunt falls within one or more existing MS/GCP approaches, all MS/GCPs protecting the existing approach(es) must be recalibrated. This applies to narrow-band shunts of any new or added frequencies other than those of existing approaches. In addition, the MS/GCPs must be recalibrated any time a narrow-band shunt is removed from an existing approach or when an approach has been modified (shortened or lengthened). Recalibration of overlapping units is not required when replacing a defective shunt in an existing approach. Prior to recalibration of overlapping units, it is not uncommon to observe significant changes (either high or low) in ED/EZ, resulting in high or low signal detector circuit operation. Recalibration must be performed on all motion sensor and grade crossing predictor models. However, when the MS/GCP(s) protecting one or more existing approaches is/are Model 3000 GCPs, recalibration must include linearization as well. In addition, if the 3000 GCPs are DAXing, recalibration of the approach length must also be included (refer to the Instruction and Installation Manual, Section 6, System Calibration).

SECTION 6 – BYPASSING INSULATED JOINTS

6.1 GENERAL

Coupling the 3000 GCP signal around (bypassing) insulated joints is permitted only under certain specific application conditions which are discussed in the following paragraphs.

Two types of couplers are used to bypass insulated joints and include wideband shunts and tunable insulated joint bypass couplers. Use of tunable insulated joint bypass couplers is limited since they can be located only in certain portions of the 3000 GCP approach and reliability is limited since they are difficult to protect from voltage surges or 60 Hz induced on the rails.

The most reliable application design is to use a DAXing GCP from the remote location to the controlled crossing (see Section 10, 3000 GCP DAX Applications). The 3000 GCP can be located at the remote site (see figure 14-10), or a six track-wire configuration can be used from the crossing (see figure 14-12).

6.2 WIDEBAND SHUNTS

The wideband shunt (8A076A) is a low impedance device designed to pass GCP frequencies in non-coded DC track circuits (see paragraph 12.10). While designed primarily to pass all GCP frequencies, the shunt passes other AC signals as well. Therefore, this shunt should never be used in AC track circuits or AC or DC coded track circuits since the code pulses will also be passed.

When insulated joints are located near the crossing and are to be bypassed with wideband shunts, the preferred application method is to extend the high-frequency island circuit beyond the insulated joints to include the wideband shunts in the island circuit.

6.3 TUNABLE INSULATED JOINT BYPASS COUPLERS

The tunable insulated joint bypass coupler (62785-f) (see paragraph 12.14) is tuned to pass the 3000 GCP frequency (f) around insulated joints in DC coded track circuits. The coupler can only be used to bypass insulated joints in certain portions of a 3000 GCP approach (see Section 6.7). Tunable insulated joint bypass couplers are available in standard Siemens frequencies of 156 Hz through 970 Hz.

6.4 INSULATED JOINT BYPASS SHUNT/COUPLER INSTALLATION

When bypassing insulated joints with wideband shunts or tunable insulated joint bypass couplers, the devices should be connected directly to the rails with leads as short as possible. To afford maximum protection from physical damage, the shunts and couplers should be encased in protective enclosures or buried. Although it is not necessary to bury the shunts and couplers below the frost line, they should be buried (either vertically or horizontally) at least 18 inches below the surface (see Figure 6-1).

6.5 MS/GCP TERMINATION SHUNT BURIAL KIT, A62776

Siemens's MS/GCP termination shunt burial kit (see paragraph 12-19) is primarily designed for protection and ease of maintenance of narrow-band termination shunts that are normally buried in the space between adjacent railroad ties. The kit consists of a 26-inch length of 6-inch diameter black PVC tubing and a 7x24-inch 1/4-inch thick steel plate. One end of the tubing is fitted with a pliable rubber cap that is secured in place by an adjustable stainless steel clamp. Two 5/8-inch diameter holes located near the capped end of the tube accommodate the shunt/coupler leads.

The enclosure is normally buried in a vertical position between adjacent ties. The shunt/coupler is then lowered into the enclosure and the two leads are fed through the holes provided. The shunt/coupler leads are secured to the ties using 3/4-inch conduit 'J' nails provided and connected to the rails using standard procedures. The cap is then secured over the top of the enclosure using the stainless steel clamp.

Installation is completed by centering the steel plate over the buried enclosure and securely fastening it to each tie using the two 1/4x3-inch lag bolts provided.

NOTE

NOTE
When splicing track connections, a crimped or welded splice should be used.

6.6 UNIDIRECTIONAL INSTALLATIONS

WARNING

WARNING
INSULATED JOINTS ARE REQUIRED AT THE CROSSING FOR UNIDIRECTIONAL INSTALLATIONS AND ARE NOT TO BE BYPASSED BY ANY TYPE BYPASS SHUNT OR COUPLER OF ANY FREQUENCY.

6.7 STEADY ENERGY DC TRACK CIRCUIT (NO CAB SIGNAL)

Bypassing insulated joints within a 3000 GCP approach should be accomplished using wideband shunts (8A076A). The total number of insulated joints that can be bypassed in an approach depends upon the GCP operating frequency but generally is as shown at the top of the following page.

**Table 6-1:
Bypassing Insulated Joints**

GCP OPERATING FREQUENCY (HZ)	MAXIMUM NUMBER OF INULATED JOINTS THAT CAN BE BYPASSED IN EACH APPROACH
86 And 114	Four Sets
156 And Above	Five Sets

6.8 CODED DC TRACK CIRCUIT

To provide the most reliable operation, it is recommended that a DAX application is used rather than tunable insulated joint bypass couplers. However, in applications where couplers must be used, a tunable insulated joint bypass coupler (62785-f) is required to bypass the 3000 GCP signal around each insulated joint. As a general rule, a maximum of two sets of insulated joints in each approach can be bypassed using tuned couplers. See Table 6-1 for minimum distance requirements.

**Table 6-2:
Minimum Distance to Insulated Joints When Coupled
With 62785-F Tunable Insulated Joint Bypass Couplers**

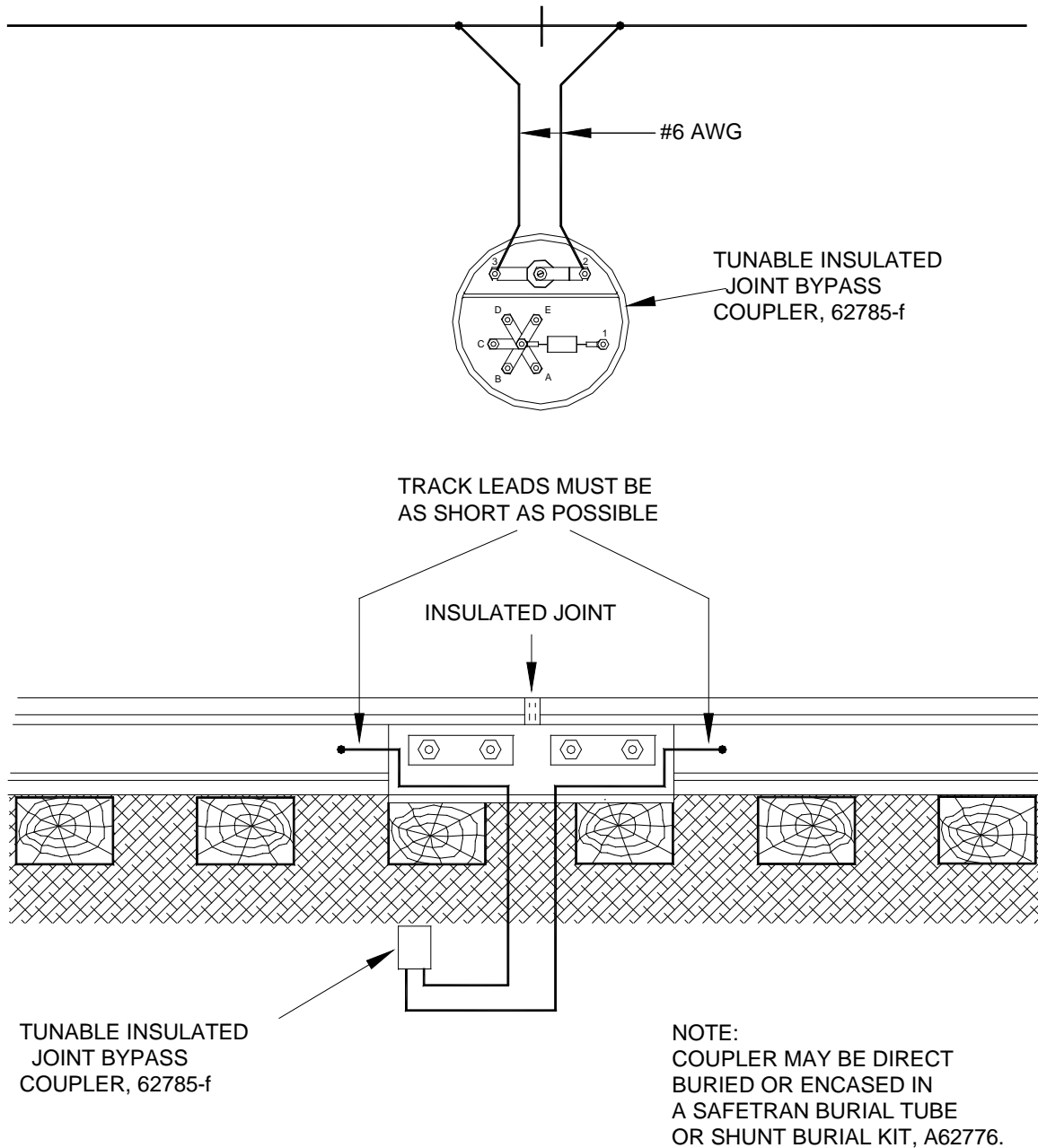
FREQUENCY (HZ)	MINIMUM DISTANCE TO FIRST SET OF INSULATED JOINTS (FEET)*	MINIMUM DISTANCE TO SECOND SET OF INSULATED JOINTS (FEET)*
86	N/A	N/A
114	Call Siemens Applications Engineering	Call Siemens Applications Engineering
151	1500	2200
⇕	⇕	⇕
211	1500	2200
212	1000	1400
⇕	⇕	⇕
348	1000	1400
349	700	1000
⇕	⇕	⇕
560	700	1000
561	500	800
⇕	⇕	⇕
790	500	800
791	400	700
⇕	⇕	⇕
979	400	700

*Distance applies to insulated joints located on the same side of the crossing.

For motion sensor applications only, the 62785-f coupler can also be used when insulated joints are located anywhere within the approach. The 62785-f couplers must be tuned in conjunction with GCP calibration.

6.9 AC TRACK CIRCUITS OR CAB SIGNAL TERRITORY

In AC track circuits or cab signal territory, use of a remote GCP or DAX application is recommended when it is necessary to extend the approach circuit.



**Figure 6-1:
Tunable Insulated Joint Bypass Coupler Installation**

SECTION 7 – TRACK LEADS

7.1 GENERAL

NOTE

NOTE

If approach distances are short (1,350 feet or less), refer to Paragraph 7.3, Track Wire Requirements Vs. Approach Length For Multiple Track Installations for track wire recommendations.
When splicing track connections, a crimped or welded splice should be used. Use of Kearney connectors should be avoided.

In the paragraphs that follow, the terms "leads" and "wires" are frequently used interchangeably. However, in those instances where a maximum wire length restriction is imposed, the length specified refers to that of a single wire and not to the total combined length of the wire run from the instrument housing to the rails and back.

In most installations in which a 3000 GCP is operating a single track circuit, four track leads are used to connect the 3000 GCP to the track; transmitter leads on one side of the crossing and receiver leads on the other. Transmitter and receiver track lead connections that run from the instrument house to the rails are to be twisted number 6 AWG, or larger if needed. In unidirectional or simulated bidirectional installations, the transmitter leads are to be located adjacent to the insulated joints. Since the transmitter leads should be as short as possible, the leads should be connected to the rails on the same side of the crossing as the instrument housing. Within the instrument housing, all wires carrying transmit and receive signals are to be number 10 AWG or larger. Leads connecting the transmitter to the rails are not to exceed the maximum lengths specified below. The lengths of the wire runs inside the instrument housing should be as short as possible. Generally, total track lead length should be limited to 500 feet. This includes the length of both the transmitter and receiver pairs. Each pair of wires should be twisted at least two turns per foot. When an island circuit is used, the GCP transmitter pair should be separated to the maximum extent possible from the receiver pair, both below ground and within the instrument housing.

NOTE

NOTE

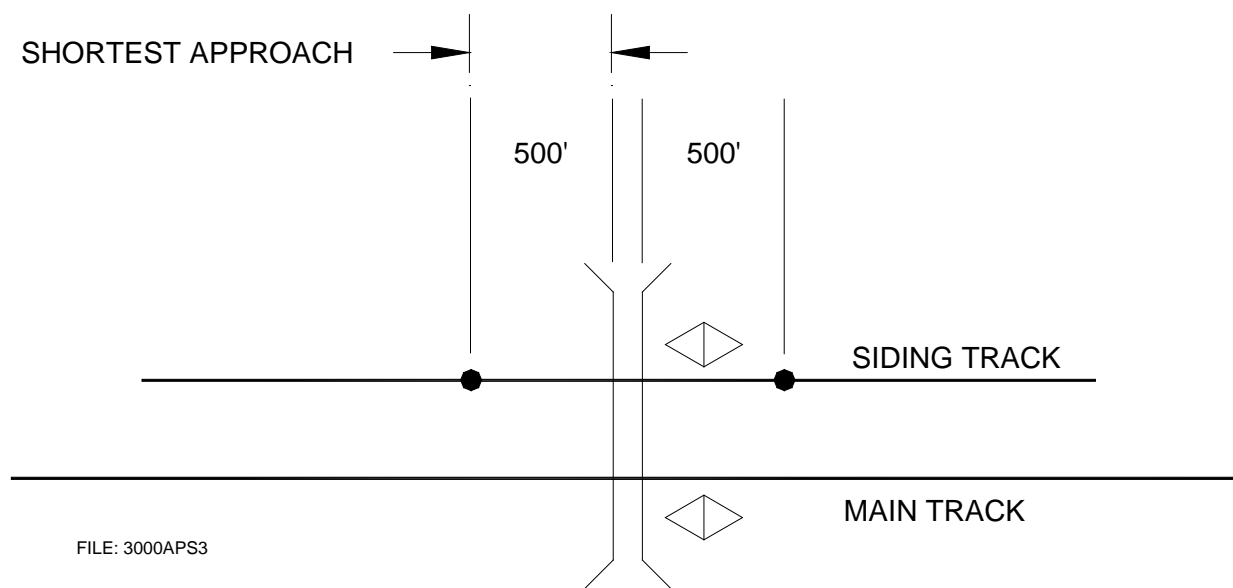
When individual lead lengths exceed the distances indicated below, a six-wire application should be considered (see Paragraph 7.3, Requirements For Six-Wire Hookup).

**Table 7-1:
Transmit Lead Lengths**

STANDARD GCP FREQUENCY (HZ)	MAXIMUM TRANSMIT LEAD LENGTH (FEET)
86	100
114	125
156	150
211	200
285-970	250

7.2 TRACK WIRE REQUIREMENTS VS. APPROACH LENGTH FOR MULTIPLE TRACK INSTALLATIONS

The minimum distance at which a low-frequency 3000 GCP will provide reliable operation is generally a function of the gauge and length of the copper transmit wires connected to the rails versus the GCP operating frequency. When a low-frequency 3000 GCP is controlling both a main track and a short siding track as illustrated below, the shortest permissible approach distance at the installation is indicated in Table 7-1 and Table 7-2. The minimum approach distances are provided for both bidirectional and unidirectional applications. The length indicated as the shortest approach for a unidirectional installation is equal to 70 percent of the distance shown for a bidirectional installation, with a minimum for both of 400 feet.



**Figure 7-1:
Minimum Approach Lengths**

For example, Table 7-2 and Table 7-3 indicate that for the lower GCP operating frequencies, the shortest approach distances require use of a six-wire connection to the rails (see paragraph 7.3). The next shortest distance requires doubling of each transmit wire (two number 6 AWG copper wires in parallel for each transmit wire) or single number 4 AWG copper wires. Refer to the tables to determine the appropriate transmit wire gauge and length for the applicable minimum approach distances.

Installations that include an approach that does not meet the minimum distance restrictions specified by Table 7-2 and Table 7-3 frequently exhibit a 20- to 30-second overring condition at the crossing. This is caused by a T1 or T2 gain check error which is indicated by a 9111 or 9112 error message generated by the 3000 GCP.

**Table 7-2:
Minimum Bidirectional Approach Length Vs. Frequency**

3000 GCP TRANSMIT FREQUENCY (HZ)	MINIMUM APPROACH LENGTH (IN FEET)				
	TRANSMIT WIRE LENGTH (NO. 6 COPPER)				
	SIX-WIRE CONNECTION (SEE NOTE)	100 FEET DOUBLE (OR 1#4)	100 FEET	150 FEET	200 FEET
86	1000	1000	1350	----	----
114	750	800	1150	----	----
156	600	700	1000	1150	1350
211	475	600	850	1000	1150
285	400	550	750	850	1000
348	400	500	700	800	850
430	400	500	650	750	750
525	400	500	600	700	700
645	400	500	550	650	650
790	400	500	500	600	600
970	400	500	475	550	550

**Table 7-3:
Minimum Unidirectional Approach Length Vs. Frequency**

3000 GCP TRANSMIT FREQUENCY (HZ)	MINIMUM APPROACH LENGTH (IN FEET)				
	TRANSMIT WIRE LENGTH (NO. 6 COPPER)				
	SIX-WIRE CONNECTION (SEE NOTE)	100 FEET DOUBLE (OR 1#4)	100 FEET	150 FEET	200 FEET
86	700	700	945	----	----
114	525	560	805	----	----
156	420	490	700	805	945
211	400	420	595	700	805
285	400	400	525	595	700
348	400	400	490	560	595
430	400	400	455	525	525
525	400	400	420	490	490
645	400	400	400	455	455
790	400	400	400	420	420
970	400	400	400	400	400

NOTE**NOTE**

When an island frequency is transmitted on the same leads as the GCP operating frequency in a six-wire hookup, maximum transmit wire length is 250 feet.

7.3 REQUIREMENTS FOR SIX-WIRE HOOKUP**WARNING****WARNING**

FOR 6 WIRE CONNECTIONS, DO NOT CONNECT ANY EXTERNAL TRACK CIRCUIT EQUIPMENT ACROSS THE TRANSMITTER WIRES.

When transmit leads cannot be limited to the maximum lengths specified in paragraph 7.1, or when a GCP located at a crossing is to be connected to a remote location up to 3,500 feet from the crossing, a six-wire track hookup must be used. In a six-wire application, two each transmit, receive, and check receive leads are required (see figures 14-12, 14-27, and 14-31). The minimum recommended copper wire size is number 6 AWG with maximum wire length (measured from the GCP signal case to the track connections) determined by the island circuit. Two conditions must be considered:

1. With an island frequency transmitted on the same leads as the GCP operating frequency
2. Without an island frequency transmitted on the same leads.

In a six-wire hookup where an island frequency is transmitted on the same leads as the GCP operating frequency, the length of the CP/island transmit leads is limited by the presence of the island frequency. When the GCP/island transmit distance is greater than 200 feet, an island frequency of 10 kHz or lower should be selected. The maximum distance that the leads can be run is 250 feet. In a six-wire hookup where no island circuit is present, the maximum length of the GCP transmit leads is 3,500 feet.

Remote GCP installations that do not require a high-frequency island circuit and are connected to the track using the six-wire track hookup do not require underground separation of the transmitter, check receive, and receiver pairs. The twisted pairs should be number 6 AWG copper and may be installed using a cable plow without regard for separation of the receiver pair. The current standard is to connect the CHK and XMT wires within 25 feet of the track feed points. Existing locations that are between 25 and 50 and do not experience check receiver errors may remain in place.

NOTE**NOTE**

Combine transmit (XMT) and check wires in underground and make only one pair of attachments to the rail.

7.4 SIX-WIRE SIMULATED BIDIRECTIONAL INSTALLATIONS

When a unidirectional 3000 GCP is applied in a six track wire configuration (using two receive wires, two transmit wires, and two check receive wires) and in a simulated bidirectional configuration where the simulated track load is located in the instrument case or bungalow along with the GCP unit (not at the track), the simulated bidirectional load must be connected to the check receive (CHK) leads as shown in Figure 14-31, not to the transmit (XMT) wires. If the simulated bidirectional load is connected to the transmit leads, an open transmitter track lead cannot be detected and can, therefore, adversely affect GCP operation. This condition exists for six-wire applications using bidirectional simulation equipment which is located in the case/bungalow (not at the tracks) regardless of which of the following types of simulated track load is used.

1. Bidirectional simulation coupler (62664-mf),
2. Single-frequency narrow-band shunt (62775-mf) used in conjunction with adjustable inductor (8A398-6), or
3. Multifrequency narrow-band shunt (62775 or 62780) equipped with simulated track inductor (8V617-distance).

In standard four track wire simulated bidirectional installations, it is permissible to connect the simulated bidirectional load to the two transmitter track leads in the bungalow as shown in Figure 14-31.

7.5 3000 GCP SYSTEMS THAT SHARE TRACK WIRES WITH EXTERNAL TRACK CIRCUIT EQUIPMENT.

When any external track circuit equipment or auxiliary track circuit equipment shares track wires with a GCP track circuit that does not have an active internal island for that track circuit or output, such as a DAX, Prime Prediction Offset, or Remote MS 2000, then the track circuit equipment must be connected in one of two ways:

- The external track circuit equipment or auxiliary track circuit equipment may be connected across the receiver wires directly, or
- When connected to the Transmitter/Check Receiver wires the external track circuit equipment or auxiliary track circuit equipment must be connected as identified in the following:

7.5.1 6-WIRE CONNECTIONS

The external equipment must be connected to the Check Receiver wires only (see Figure 14-31).

WARNING

WARNING

FOR 6 WIRE CONNECTIONS, DO NOT CONNECT ANY EXTERNAL TRACK CIRCUIT EQUIPMENT ACROSS THE TRANSMITTER WIRES.

7.5.2 4-WIRE CONNECTIONS

NOTE

NOTE

GCP 3000/MS 2000 four wire systems have the Check Receiver tied to the Transmitter in the GCP case.

The Check Channel Receiver wires may connect either to the Transmitter wires at the same point or prior to connecting to the other track circuit equipment (see Figure 14-31).

WARNING

WARNING

DO NOT CONNECT ANY EXTERNAL TRACK CIRCUIT EQUIPMENT ACROSS THE TRANSMITTER PRIOR TO CONNECTING IT TO THE CHECK CHANNEL RECEIVER WIRES.

The Check Channel Receiver wires may connect to the external track circuit equipment prior to connecting to the transmitter track wires (see Figure 14-31)

WARNING

WARNING

CONNECTIONS MUST BE ARRANGED SO THAT AN OPEN WIRE OR OPEN CONNECTION WILL NOT RESULT IN THE TRANSMITTER WIRES BEING CONNECTED TO THE AUXILIARY TRACK CIRCUIT EQUIPMENT UNLESS THE CHECK RECEIVER IS ALSO CONNECTED (REFER TO FIGURE 7-2).

TRACK LEADS

External track circuit equipment includes, but is not limited to, 80049 DC Exciter Panels, Electronic Coded Track, AFO Track circuits, Track batteries or relays, surge suppressors (not including air gap arresters) or Bidirectional Simulation Couplers.

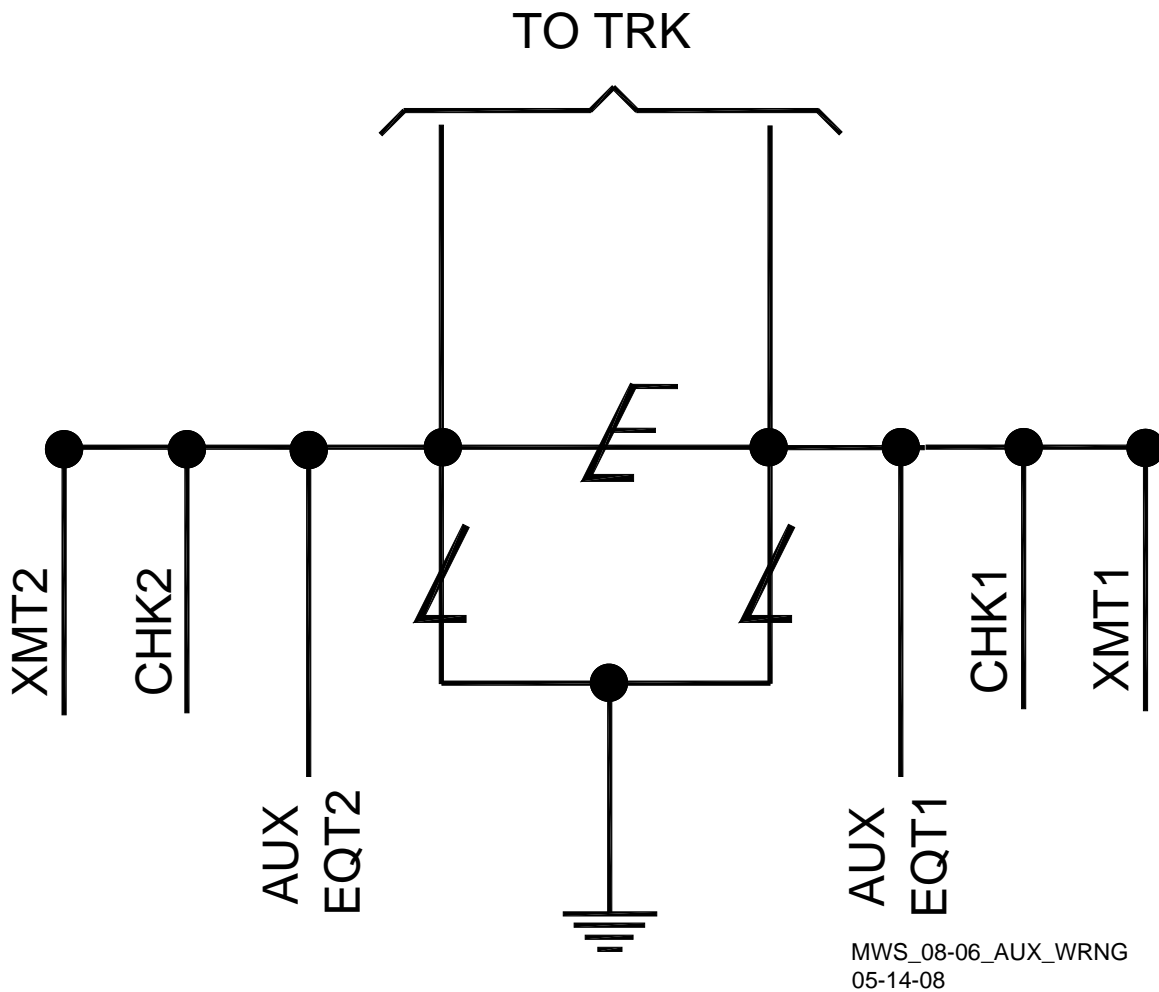


Figure 7-2:
Proper Connections of Track Wires

SECTION 8 – TRACK CIRCUIT ISOLATION

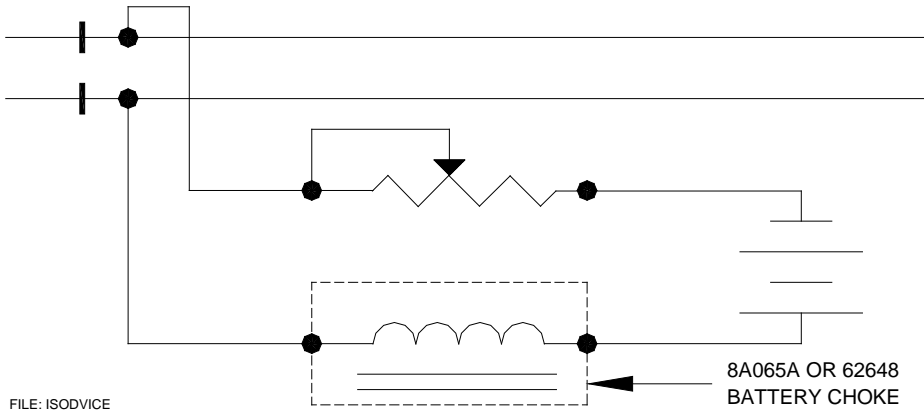
8.1 GENERAL

Several types of track circuit isolation devices are available for both DC and AC coded track applications. Since there are a number of variations in DC coded track such as relay type and associated operating current, decoding method, current and voltage transmitted and received, track circuit length, transmit and receive code polarity, DC code frequency, pulse width, etc., the guidelines presented in the following paragraphs are general in nature and no attempt has been made to cover all applications. Also, as additional field experience is gained, improved or changed application methods may result. If there are any questions concerning these guidelines or applications, contact Siemens Application Engineering for assistance.

Battery chokes or code isolation units are required to isolate GCP systems (see figure 14-30) as described in the following paragraphs. These battery chokes and code isolation devices are designed for mounting inside weatherproof enclosures. Refer to Section 12, Auxiliary Equipment, for physical descriptions of these devices.

8.2 STEADY ENERGY DC TRACK CIRCUITS

All DC track circuits with batteries located within a 3000 GCP approach should be equipped with a battery choke. Either of the following battery chokes may be used; part number 8A065A or 62648 (see limitations in the following paragraphs). The diagram below shows a typical application.



**Figure 8-1:
Typical Battery Choke Application**

Operation of long DC track circuits with very low ballast conditions may be affected by the DC resistance (DCR) of the 8A065A battery choke. Such track circuits should use the 62648 battery choke, which has a DCR of 0.10 ohm (DCR of 8A065A is 0.40 ohm).

WARNING

WARNING
IN APPLICATIONS WHERE THE CHOKE IS LOCATED WITHIN A MODEL 300 OR 400 GCP APPROACH, THE 8A065A BATTERY CHOKE MUST BE USED.

When a rectified track circuit is used and the GCP is operating at 114 Hz, an 8A076A wideband shunt should also be used along with the battery choke to eliminate 120 Hz ripple. The diagram below illustrates this application.

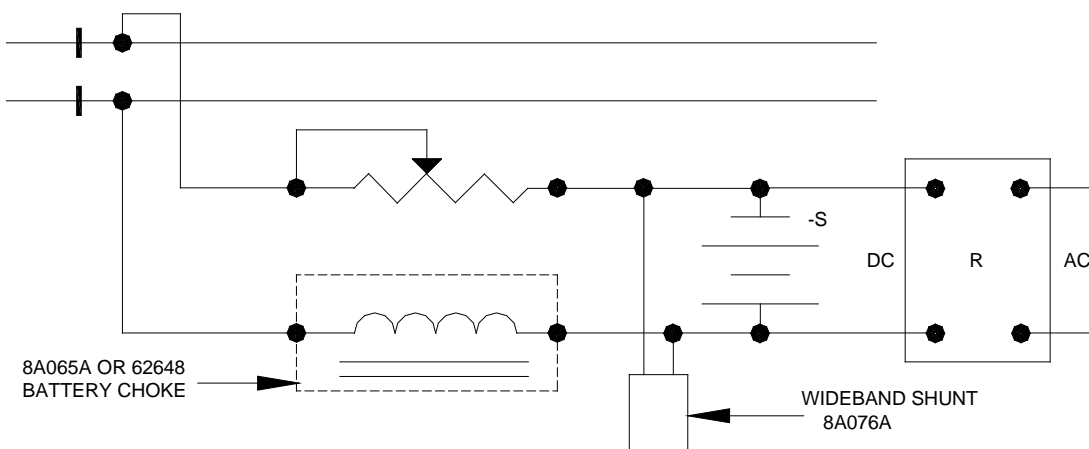


Figure 8-2:
Typical Rectified Track Application

8.3 GEO ELECTRONIC DC CODED SYSTEM

The standard Siemens 3000 GCP frequencies of 86 Hz and above are compatible with GEO. Isolation circuits are generally not required in the GEO transmitter rail connections. GCP Frequencies of 86, 114, 156, and 211 Hz require use of maximum current, track devices, and the GEO Track Noise Suppression Filter, A53252. The GEO Filter must be installed at the signal location for the above mentioned frequencies.

8.4 ELECTRO CODE ELECTRONIC DC CODED SYSTEM

Model 3000 GCP frequencies of 86 Hz and above can normally be used with Electro Code. All frequencies of 211 Hz and lower require use of maximum current track drive. In certain instances, 285 Hz may also require maximum current.

For frequencies of 211 Hz and lower, an Electro Code track filter (TF-freq) may be required when the Electro Code transmitter is located within the 3000 GCP approach. As with any coded track system, the lower the Electro Code transmit power level, the less interference with GCP units.

8.5 RELAY CODED DC TRACK

Most relay coded DC track installations require use of DC code isolation units such as the 6A342-1 for both battery and relay ends. The code isolation unit is a filter that helps prevent coded track battery and track relays from causing high interference with the 3000 GCP.

⚠ WARNING	<p><u>WARNING</u></p> <p>ALWAYS VERIFY PROPER CODE SYSTEM OPERATION AFTER INSTALLING THE ISOLATION UNIT.</p>
------------------	--

NOTE	<p><u>NOTE</u></p> <p>Typical applications are shown in the following sections. For other applications, please review with Siemens Application Engineering.</p>
-------------	--

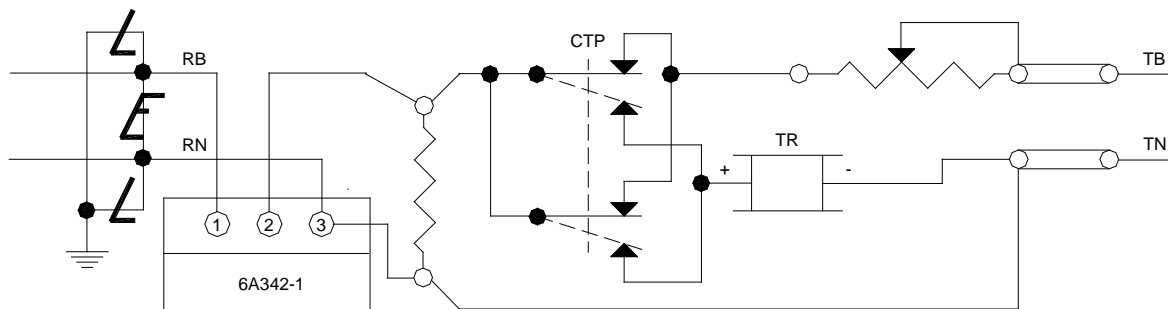
The 6A342-1 DC code isolation unit is used in most single polarity code systems while the 6A342-3 unit is used in GRS Trakode (dual polarity) relay systems.

All wiring to terminals 1 and 2 on the isolation units should be number 6 AWG. This significantly reduces current losses to the track relay during periods when low track ballast conditions are prevalent. Frequencies below 211 Hz require maximum current.

Various applications for the track isolation units are discussed in the paragraphs that follow.

8.5.1 Single (Fixed) Polarity Systems

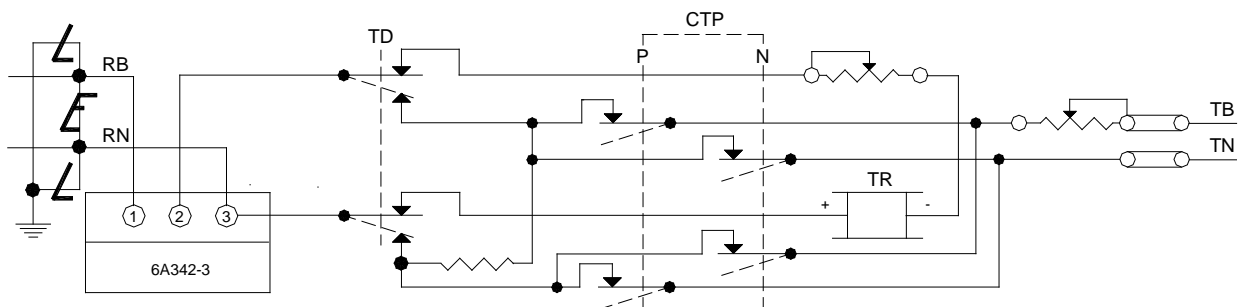
The 6A342-1 code isolation unit can be used in most single (fixed) polarity code systems. A single polarity code system must have the same received and transmitted polarities to use this code isolation unit. Most rate code systems (75, 120, and 180 ppm) are of this type. The diagram below shows a typical 6A342-1 code isolation unit installation in a single polarity code system.



**Figure 8-3:
Single Polarity System**

8.5.2 GRS Trakode (Dual Polarity) Systems

The diagram below illustrates the 6A342-3 code isolation unit installed in a GRS Trakode system. To install the unit as shown, a transfer delay (TD) relay must be used. Do not install any code isolation circuit in GRS Trakode without the use of the TD relay.



**Figure 8-4:
GRS Dual Polarity System Application**

8.5.3 Dual Polarity (Polar) Coded Track Systems Other Than GRS Trakode

A dual polarity system is one in which the received code polarity is opposite that of the transmitted code. The 6A342-3 code isolation unit can be used in a dual polarity system. However, two 6A342-3 units must be placed at each end of the circuit for proper filtering. The application will depend upon the track circuit configuration. Contact Siemens Application Engineering for assistance in dual polarity code systems.

8.6 CAB SIGNAL AC

Application of 3000 GCP systems in cab signal territory using 60 Hz AC Code Isolation Unit, 8A466-3, or 100 Hz Isolation Unit, 8A471-100, is shown below. For other installations, contact Siemens Application Engineering for assistance.

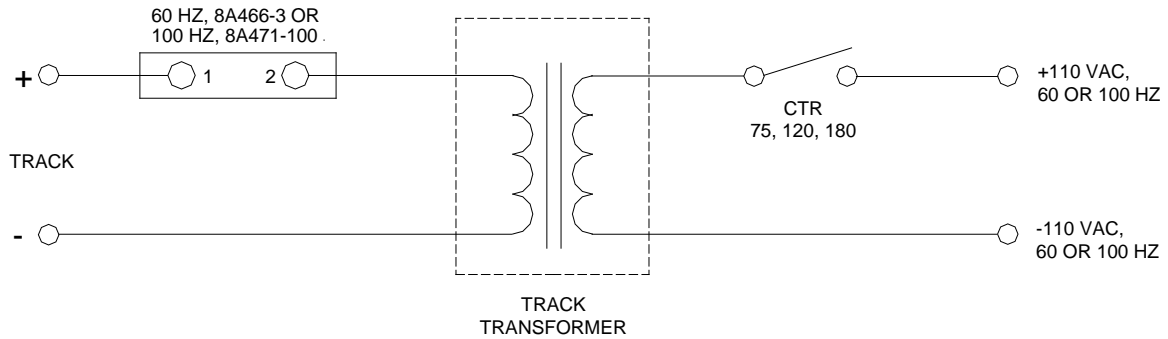


Figure 8-5:
Typical Code Isolation Application in Cab Signal Territory

8.7 STYLE C TRACK CIRCUITS

The 60 Hz AC code isolation unit (8A466-3) (see Figure 12-24) is used with style C track circuits as shown below. For special applications, 180 Hz AC code isolation unit (8A471-180) (see Figure 12-28) is also available. Contact Siemens Application Engineering for specific information.

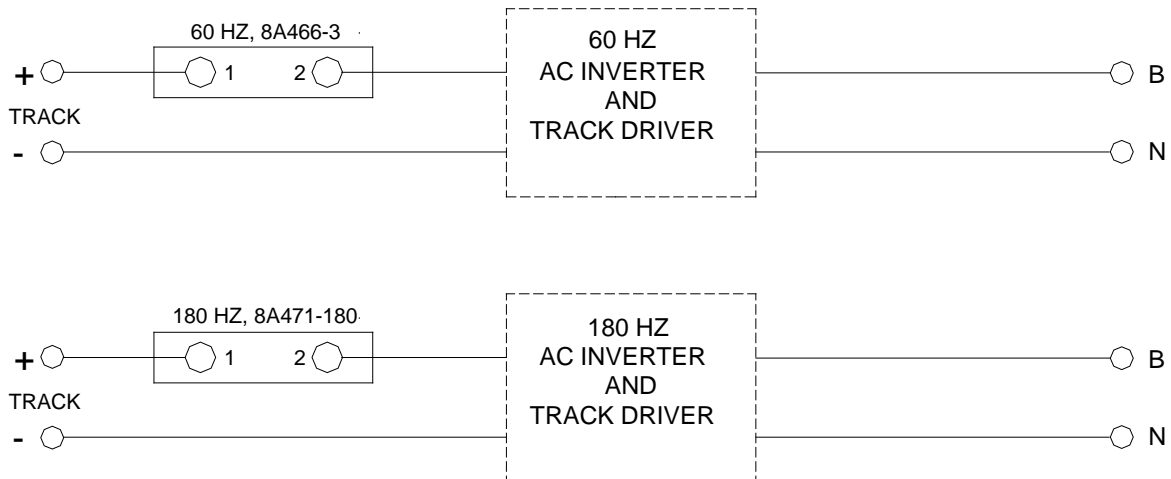


Figure 8-6:
Typical Style C Application

SECTION 9 – UNIDIRECTIONAL OPERATION

9.1 GENERAL

All 3000 GCPs installed for unidirectional operation require insulated joint separation as shown in the diagrams in paragraph 9.5. The insulated joints should be located as nearly opposite each other as possible and must not be bypassed by coupling devices of any kind. In general, to ensure optimum GCP operation over varying ballast conditions, and where unidirectional GCP approaches are longer than 2,000 feet, the simulated bidirectional application should be used (see paragraphs 9.2 and 12.2).

Unidirectional installations are frequently used to expedite movement of closely following trains and to ensure adequate warning time at crossings in which a standing car or train occupies an opposite approach circuit.

When long approach circuits are required due to the presence of high-speed trains, unidirectional installations are used with insulated joints to permit repeating of selected lower frequencies. Unidirectional installations are also used with remote GCPs when extending crossing approaches beyond existing track circuit limits in coded track or cab signal territory.

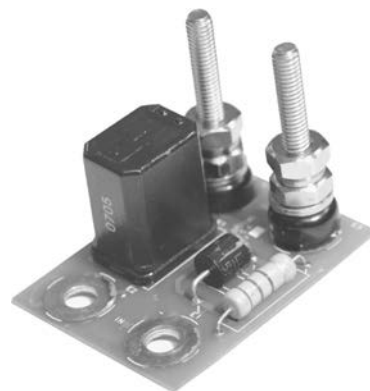


WARNING

WARNING

WHEN A 3000 GCP IS APPLIED SO THE UAX, ISL RLY, MS/GCP CONTROL AND/OR ENA INPUT ON A SINGLE 3000 GCP AND/OR 2000 MS UNIT WILL BE DIRECTLY DRIVEN BY (NO RELAY ISOLATION) THE GCP RLY (3000 GCP) AND/OR MS RLY (2000 MS) OUTPUT OF ANOTHER UNIT, THE SIEMENS RELAY ADAPTER MODULE A80170 MUST BE USED. REFER TO PARAGRAPH 9.1.1 FOR INFORMATION AND INSTALLATION INSTRUCTIONS ON THE RELAY ADAPTER MODULE A80170.

9.1.1 RELAY ADAPTER MODULE, A80170



**Figure 9-1:
A80170 Relay Adapter Module**

Relay Adapter Module (Siemens P/N 8000-80170-001) (see Figure 9-1) must be installed in all existing and future applications where a 3000 MS will be used to directly drive (no relay isolation) any UAX, ISL RLY, MS/GCP CONTROL and/or ENA input on one 3000 GCP and/or 2000 MS unit by the GCP RLY (3000 GCP) and/or MS RLY (2000 MS) output of another unit. The Relay Adapter Module A80170 is installed externally to the 3000 GCP unit and can be wired into the system as shown in Figure 14-9.

NOTE**NOTE**

The Relay Adapter Module is not required where vital relays are used as an interface between the UAX, ISL RLY, MS/GCP CONTROL and/or ENA inputs of one unit and the GCP RLY (3000GCP) or MS RLY (2000MS) output of another unit.

Perform the following steps to install the Relay Adapter Module on a 3000 GCP Unit:

1. Remove all wires from Terminal Block (TB) 1-9 on the front panel, including any event recorder wires (TB 1-9 = GCP RLY (+)).
2. Connect all wires removed in step 1 to the OUT (+) terminal on the A80170 Relay Adapter Module.
3. Remove all wires from terminal 10 on the front panel, including any event recorder wires (TB 1-10 = GCP RLY (-)).
4. Connect all wires removed in step 3 to the OUT (-) terminal on the A80170 Relay Adapter Module.
5. Slide the mounting holes at the base of the A80170 Module onto terminals 9 and 10 of the 3000 GCP unit. Fasten the A80170 Module securely using appropriate AREMA-compliant hardware.
6. When installation of the A80170 module is complete, test UAX, ISL RLY, MC/GCP CONTROL and/or ENA circuits per railroad policies and procedures.

9.2 UNIDIRECTIONAL OPERATION - BIDIRECTIONAL SIMULATION

The bidirectional simulation technique may be used at any unidirectional MS/GCP installation to obtain the benefits associated with bidirectional operation. The technique involves applying a termination shunt in series with an adjustable inductor, both of which are wired in parallel with the track connections so that, electrically, the GCP is 'seeing' two approaches of equal length; the actual approach plus the simulated approach consisting of the shunt and inductor, which are located in the instrument housing or other suitable enclosure. The inductor is always adjusted to be the same length or slightly longer than the actual approach length.

WARNING**WARNING**

THE 3000 GCP AND 4000 GCP ARE THE ONLY UNITS THAT CAN OPERATE UNIDIRECTIONALLY IN A SIMULATED BIDIRECTIONAL MODE WHILE DAXING.

NOTE**NOTE**

At insulated joints, if a narrow band shunt is used with a simulated track load (dummy load) of 1,500 feet or greater, it must be considered as one frequency or channel lower for loading effects; e.g., if 285, then treat as 211. The 3000 GCP unit must be programmed for bidirectional operation.

9.3 BIDIRECTIONAL SIMULATION COUPLER, 62664-MF

Bidirectional Simulation Coupler, 62664-Mf, is a convenient, compact, shelf- or backboard-mounted unit containing a narrow-band shunt of the same frequency as the GCP and an adjustable inductor (simulated track) (see paragraph 12.2).

9.4 SIMULATED TRACK INDUCTOR, 8V617

A Simulated Track Inductor, 8V617, is also available and can be installed inside of a multifrequency narrow-band shunt (62775/62780) to accomplish bidirectional simulation. The inductor is available in 200-foot increments up to 4,000 feet and is connected between terminals of a multifrequency narrow-band shunt, which is located either at the tracks or within a case/bungalow (see paragraph 12-11). The inductor must be the same length or slightly longer than the actual approach.

9.5 INSULATED JOINTS LOCATED AT THE CROSSING

The diagram below illustrates a typical 3000 GCP unidirectional installation with insulated joints. The two GCPs can be independent units or both can be housed in the same case; however, only GCP number 1 is required to be equipped with an island module (80011). The track leads of GCP number 1 are connected to the rails in a standard bidirectional manner as shown in figure 14-2. The transmit wires should be located adjacent to the insulated joints.

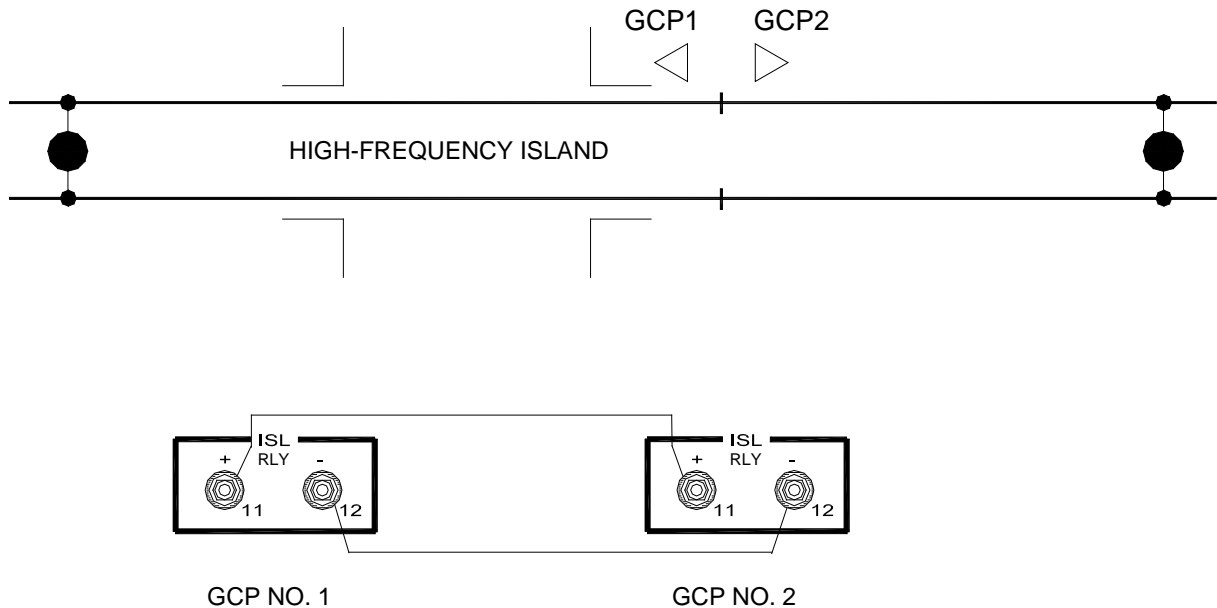


Figure 9-2:
Connecting Island Relays with Insulated Joints at the Crossing

NOTE

NOTE
 Island circuit length should not exceed 30 percent of the GCP approach length, or a maximum of 300 feet. Refer to Section 4, Island Frequency Selection And Island Length for additional information.

The transmitter and receiver track leads of GCP number 2 are connected to the same points on the respective rails adjacent to insulated joints. The (+) island relay terminals of both GCPs are connected together, as are the (-) terminals. This prevents a ring-out as the train leaves the crossing since GCP number 2 is not equipped with an island module. The GCP 1 and 2 track leads must not be transposed to ensure that any insulated joint breakdown is properly processed by the two GCPs. See the diagram below and figure 14-5 for equipment and wiring information.

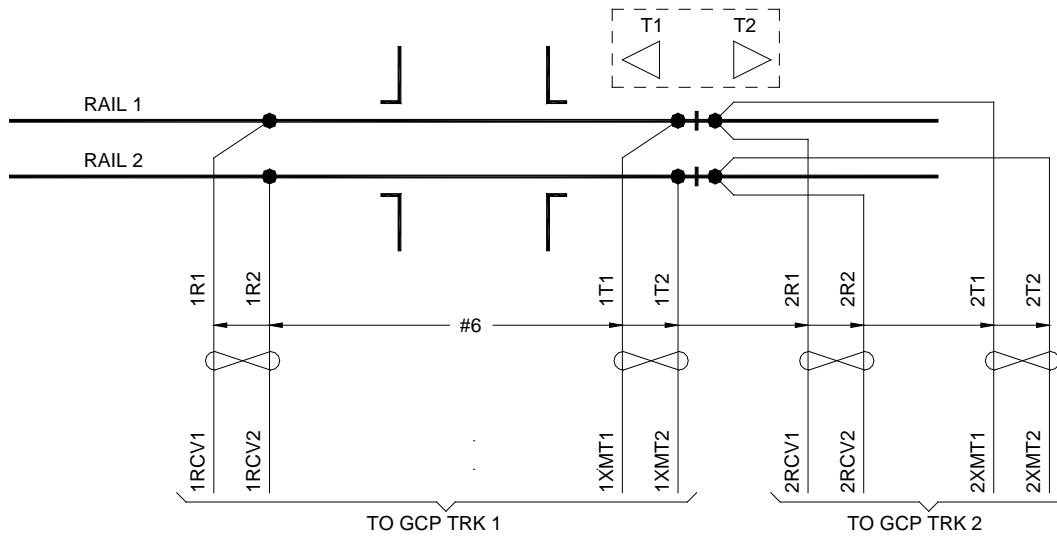


Figure 9-3:
Track Wiring Connections with Insulated Joints at the Crossing

The diagram below illustrates a typical remote 3000 GCP unidirectional installation with insulated joints. The GCPs can be separate units or both can be housed in the same case. When both units are housed in the same case, a six-wire track hookup can be used. When the units occupy separate cases, standard unidirectional track connections are used. To provide relay drive output for a prime prediction offset (DAX), battery + 12 VDC (B12) must be applied to the ISL RLY + terminal of the remote unit while battery - 12 VDC (N12) is applied to the ISL RLY - terminal.

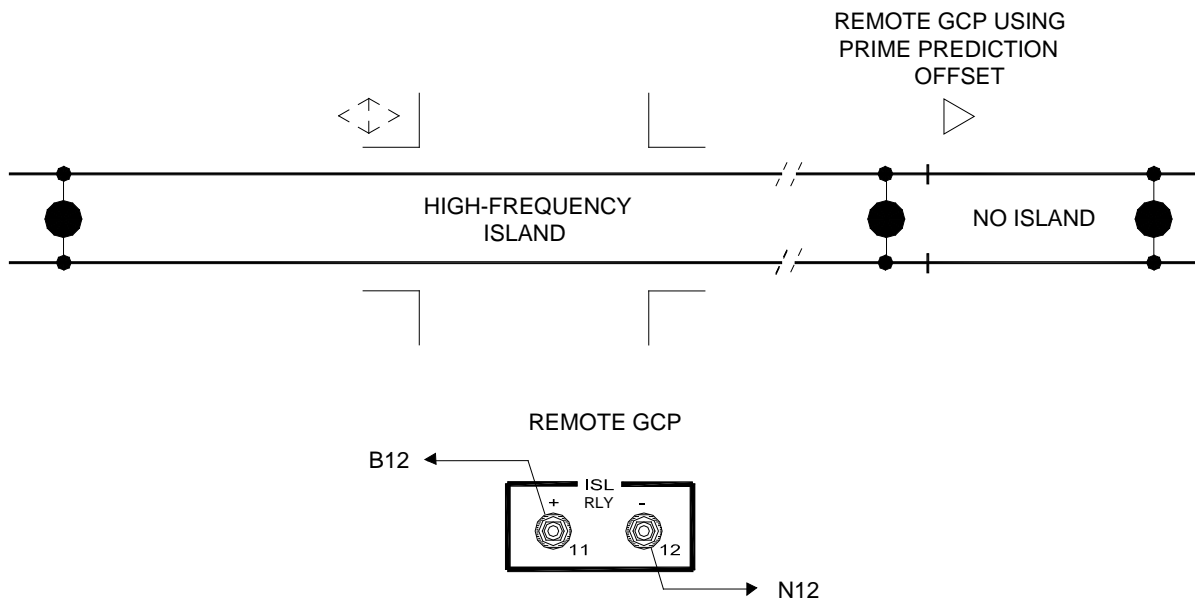
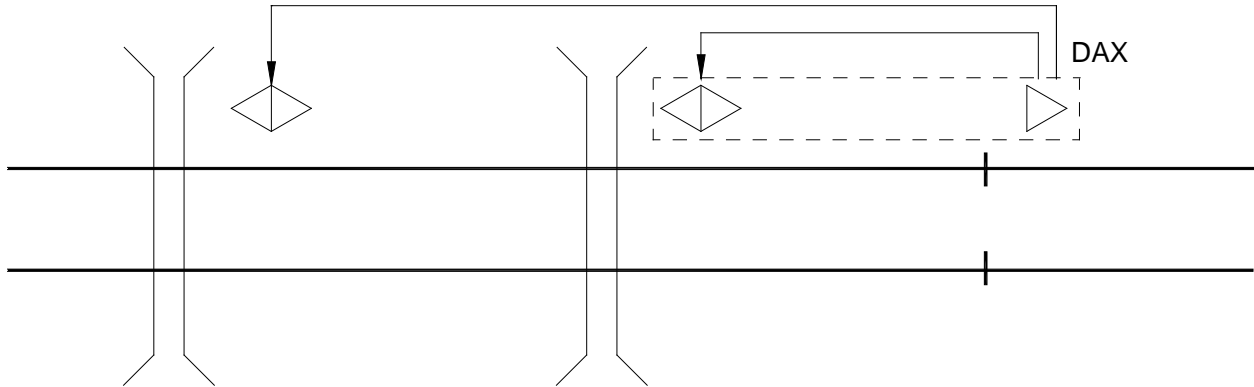


Figure 9-4:
Relay Drive Output for Prime Prediction Offset In Unidirectional Application

When a remote unidirectional GCP and a bidirectional crossing GCP are operating from the same case but DAX modules (80016) are used to control other crossings (see Figure 9-5), prime prediction offset in the unidirectional GCP is not used. Therefore, prime prediction offset for the remote GCP should be programmed for 9,000 feet to prevent the remote GCP from inadvertently starting the crossing.



**Figure 9-5:
Unidirectional GCP in Same Case with
Bidirectional GCP DAXing to Other Crossings**

9.6 DC ISLAND CIRCUITS

When a DC island circuit is used in place of island module (80011), battery B (+) must be applied to the island relay drive terminals of both GCP number 1 and GCP number 2 over a front contact of the DC island repeater relay as shown in the diagram below. When the island is occupied, the relay back contact applies battery N (-) to the island relay drive terminals.

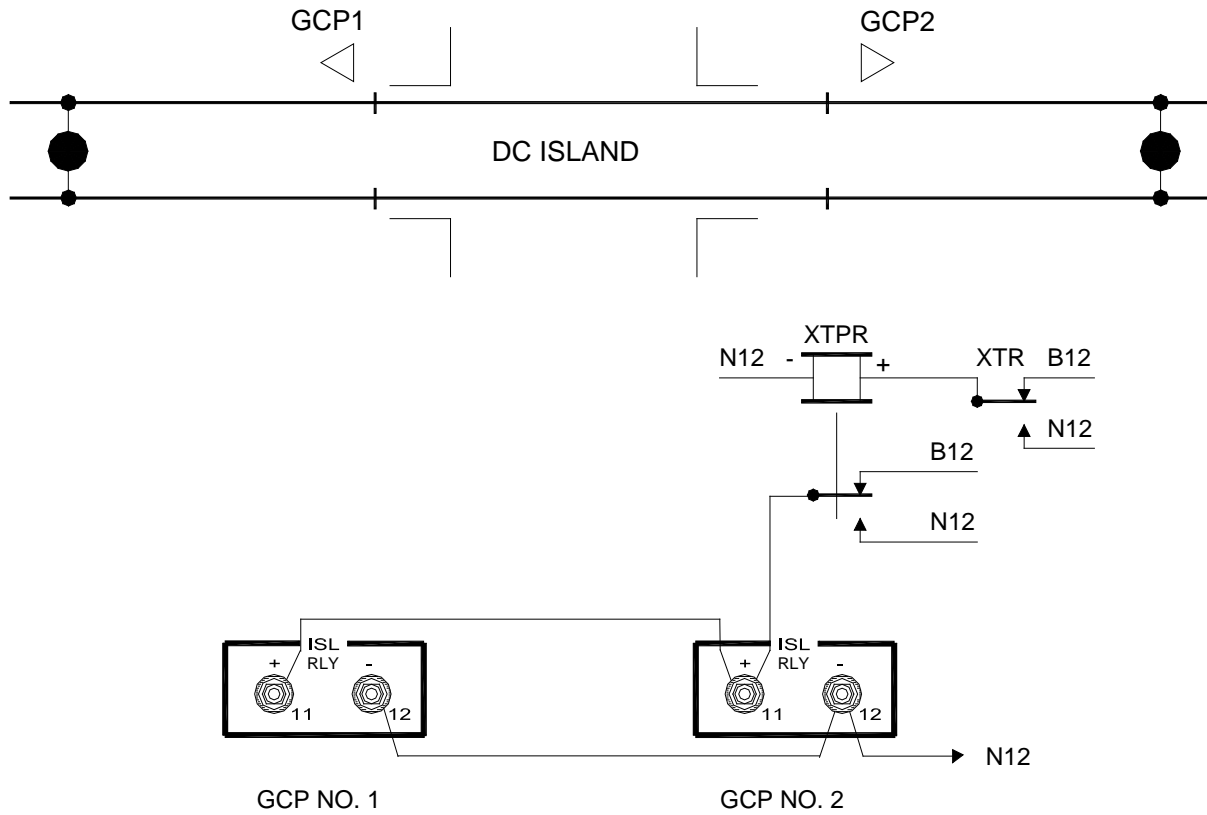
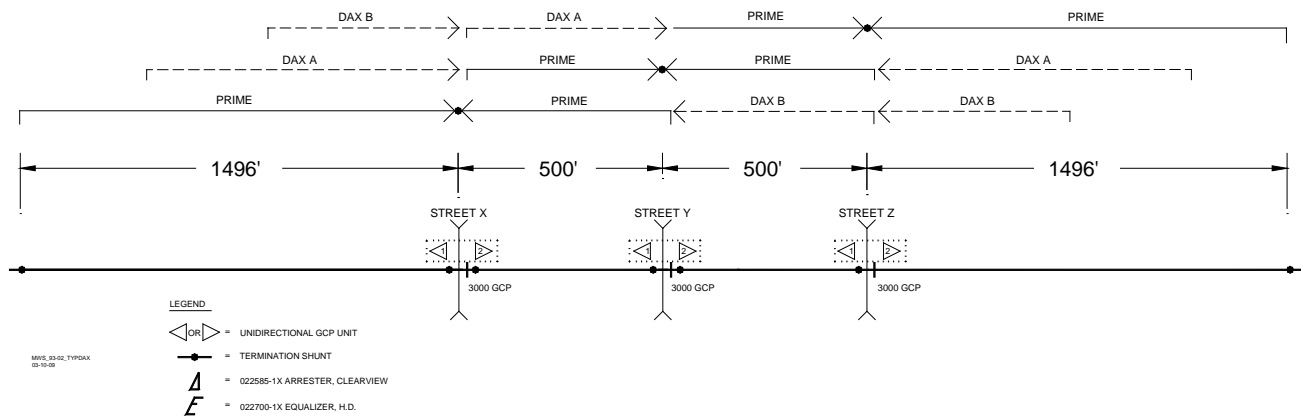


Figure 9-6:
Wiring of Island Relay Connections in DC Island Circuits

SECTION 10 – 3000 GCP DAX APPLICATIONS

10.1 INTRODUCTION TO DAX OPERATION

When a crossing is protected by two unidirectional 3000 GCPs, a set of insulated joints that electrically isolate the two GCP systems is located on one side of the street. The insulated joints cannot be bypassed with couplers of any type. Therefore, when the approach distance between adjacent, unidirectionally equipped crossings is not sufficient to provide the operating time required, the approach cannot be extended by passing the GCP frequency around the insulated joints with bypass couplers. However, the GCP provides a means of extending the controls by adding a DAX (downstream adjacent crossing) module (80016). Each GCP case (except Models 3000ND and 3000ND2) can accommodate two DAX modules (four in the Model 3008 and 3008D2 eight-DAX units) and each module is equipped with two DAX prediction circuits, providing a total of four (eight) independent DAX outputs. Each of the four (eight) DAX circuits may be field programmed to operate with either track 1 or track 2 of the GCP (eight DAX units are single track only). Refer to Figure 10-1 for the following discussion of DAX operation.



**Figure 10-1:
Typical DAX Application**

Unidirectional GCPs are used at streets X, Y, and Z, which are 500 feet apart. A single GCP case with two transceiver modules is required at each street. For example, to provide 30 seconds operating time at a maximum train speed of 30 miles per hour, the approach distance required would be 1,496 feet (30 seconds warning time plus 4 seconds system response time multiplied by 44 feet per second equals 1,496 feet). Therefore, to provide adequate crossing start distance, one DAX module (two DAX circuits) is required at each street. Two DAX circuits are used in GCP number 1 at street X, one DAX circuit each in GCPs 1 and 2 at street Y, and two DAX circuits in GCP 2 at street Z.

The westbound control chart line for street X shows prime (prediction) control between streets X and Y, DAX B control (in GCP 2 at street Y) between streets Y and Z, and DAX B control (in GCP 2 at street Z) to provide the initial 500-foot approach distance east of street Z. Downstream adjacent crossing (DAX) control requires a line circuit (open line or cable) between the GCP with the DAX module and the GCP receiving the normally energized DAX output.

To illustrate DAX control for street X, consider a westbound train approaching street Z at 30 miles per hour. When the train is 30 seconds from street X, the DAX B circuit assigned to GCP 2 at street Z predicts and removes relay drive from the front panel DAX B relay drive (RLY + and -) terminals. The line circuit from these terminals extends to a vital AND-gate (see Figure 10-2) at street Y. When energy is removed

from the vital AND-gate input, the line circuit from street Y (AND-gate output) to the UAX input on GCP 2 at street X is also deenergized. Removing energy from the UAX terminals deenergizes the front panel GCP RLY (relay drive) terminals on GCP 2 at street X causing the warning signals to operate. When the train crosses the insulated joints at street Z, GCP 2 at street Y detects the train causing DAX B in that unit to predict and deenergize the DAX B front panel terminals on that unit (second input to vital AND-gate).

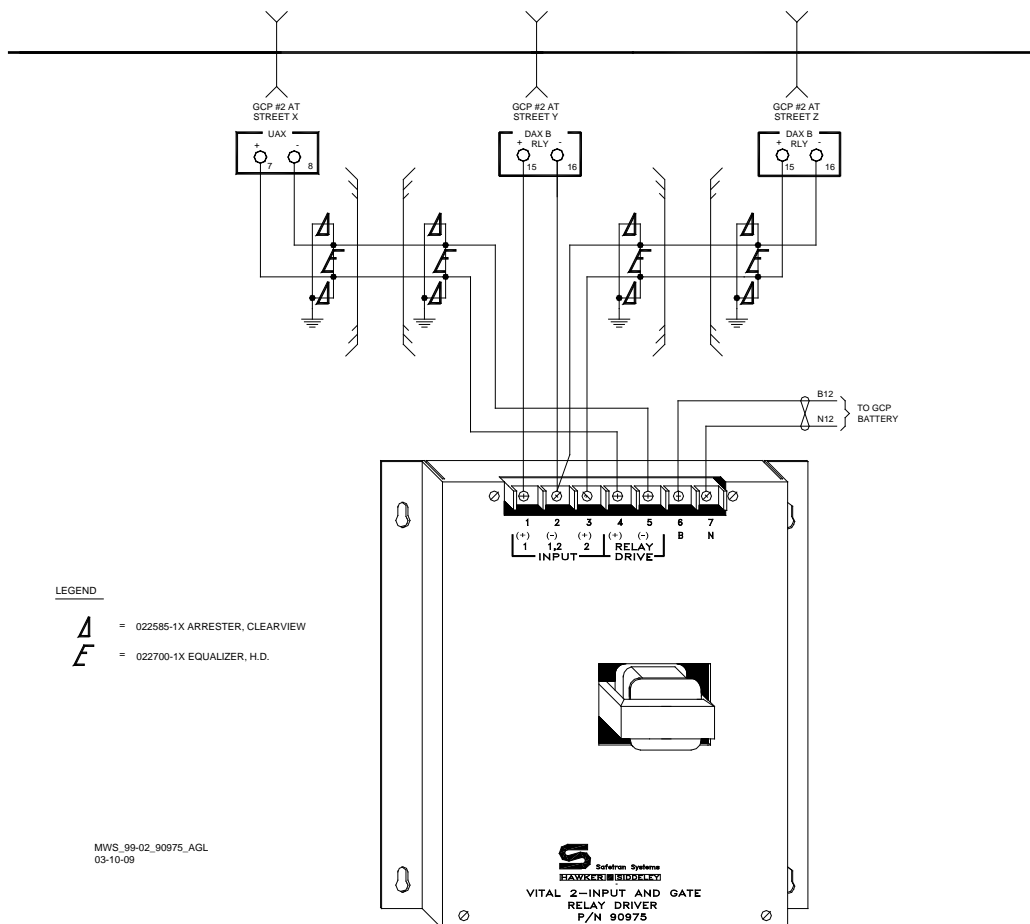


Figure 10-2:
Typical DAX/UAX Connections Using Vital AND Gate, 90975

This ensures that the line circuit to the GCP UAX terminals on GCP 2 at street X remains deenergized (the vital AND-gate output will be energized only when both inputs to the AND-gate are energized).

All DAX modules (80016) are identical and require no on-board module programming or jumpers. All on-site programming, including DAX offset distance (distance to controlled street), approach distance (street where DAX is located), and DAX warning time are entered via the keypad (see paragraph 10.5).

Upstream adjacent crossing (UAX) control capability is also included with all 3000 GCP systems and the associated circuits are contained on the relay driver module (80013). The function of the UAX circuits is to introduce a specific time delay interval in the XR relay recovery following re-establishment of the DAX output. This ensures that GCP relay drive does not recover before the prime GCP detects the train. The time delay is programmable from 0 to 500 seconds but is generally set for 25 seconds.

When the UAX option is used, the desired pickup delay time must be entered via the keyboard. When the UAX option is not used, entering a 0 (zero) results in an OFF indication on the display.

WARNING**WARNING**

WHEN THE UAX FEATURE IS OFF (ZERO TIME ENTERED), THE UAX TERMINALS (ON THE 3000 GCP FRONT PANEL) HAVE NO CONTROL OVER MS/GCP RELAY DRIVE. WHEN THE UAX FEATURE IS PROGRAMMED BETWEEN 1 AND 500 AND A NOMINAL 12 VOLTS IS REMOVED FROM THE UAX TERMINALS, MS/GCP RELAY DRIVE IS IMMEDIATELY DEENERGIZED. WHEN 12 VOLTS IS REAPPLIED TO THE UAX TERMINALS, THE MS/GCP RELAY DRIVE ENERGIZES AFTER THE UAX PICKUP DELAY TIME HAS ELAPSED (PROVIDING NO OTHER CONDITION KEEPS THE MS/GCP RELAY DRIVE DEENERGIZED).

10.2 CONTROLLING DOWNSTREAM CROSSINGS

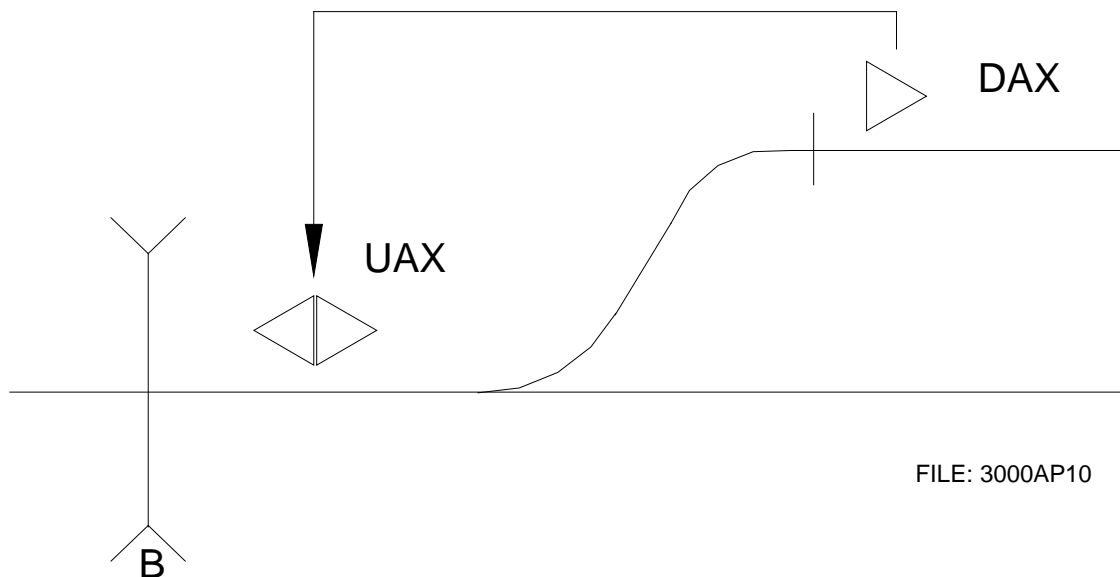
The 3000 GCP is capable of controlling a downstream crossing from a remote location (other than a crossing) by using either the prime prediction offset feature or DAX modules (80016). At a crossing, unidirectional GCPs equipped with an island circuit must use DAX modules.

10.3 MAJOR DAX APPLICATIONS

There are two major applications for DAXing. These include (1) starting one or more crossings from a remote location other than a crossing where insulated joints cannot be bypassed and (2) starting a crossing from another crossing to enable operation in conjunction with the first crossing.

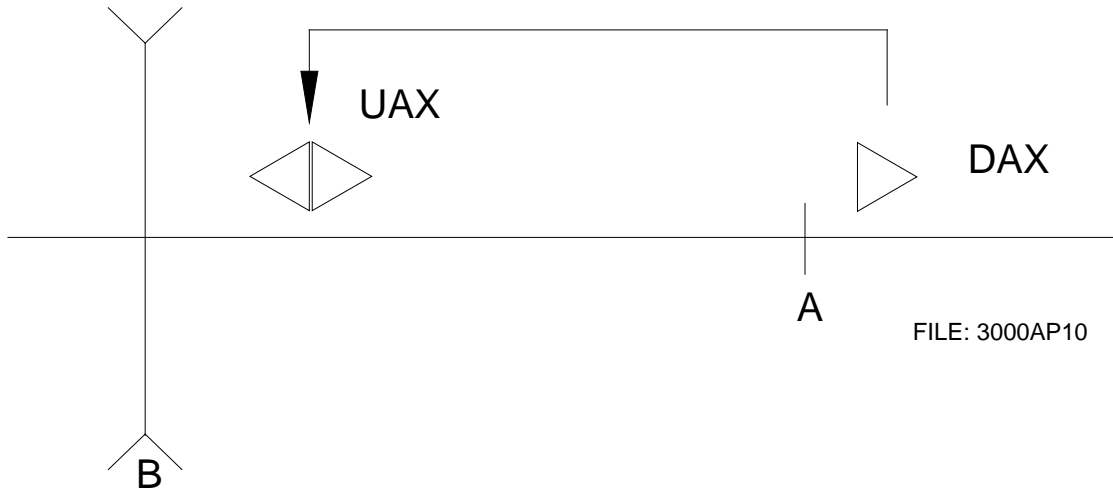
Examples of remote starts where insulated joints cannot be bypassed include starts from:

1. A remote siding



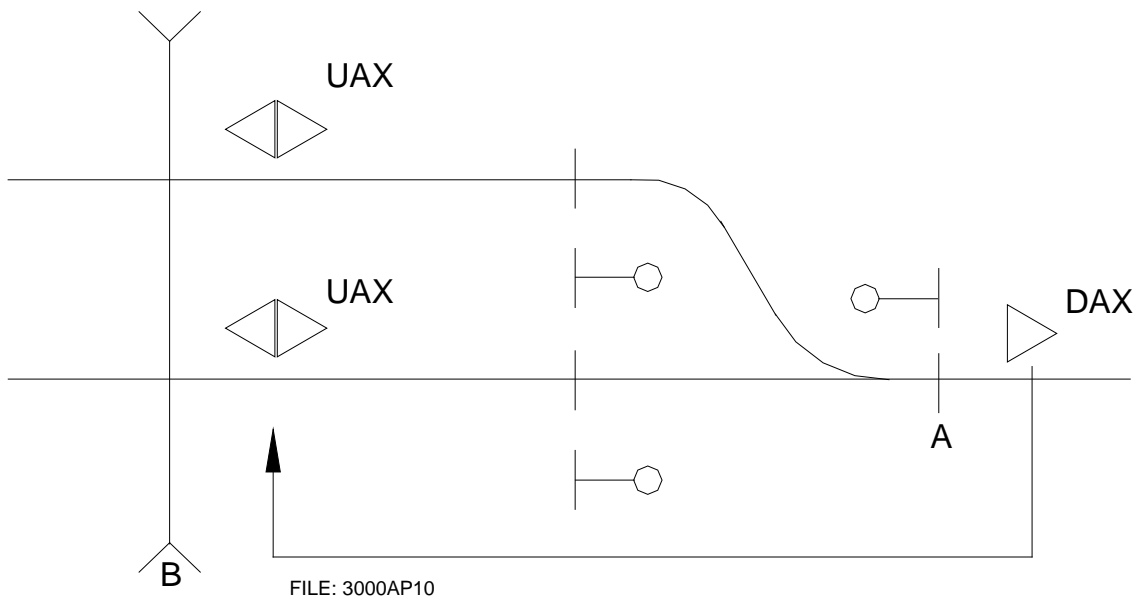
**Figure 10-3:
DAX From A Remote Siding**

2. A remote location such as in DC coded track where bypass couplers cannot be used at insulated joints A.



**Figure 10-4:
DAX in DC Coded Track without Bypass Couplers**

3. A remote end of siding location where no bypass couplers are used at insulated joints A.



**Figure 10-5:
DAX From A Remote Siding without Bypass Couplers**

The second major application area is to provide a remote start from another crossing.

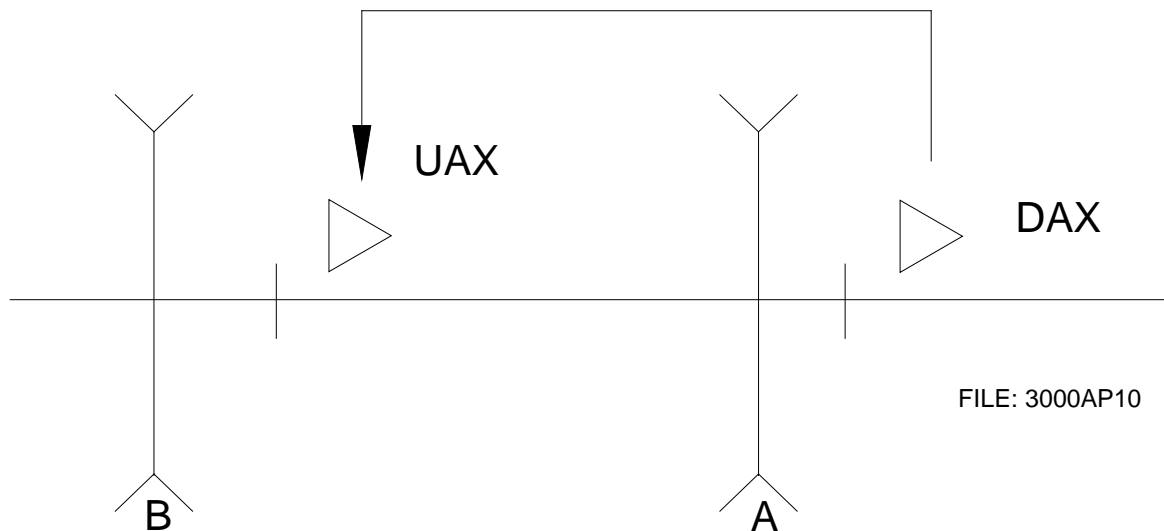


Figure 10-6:
DAX to Provide Remote Start From Another Crossing

10.4 COMMON DAX APPLICATION GUIDELINES

The two application areas discussed in paragraph differ in certain aspects; however, the following guidelines apply to both.

1. The GCP equipped for DAXing must be installed as a unidirectional or simulated bidirectional system at a set of insulated joints. No wideband, narrow-band, or audio over- lay bypass couplers may be installed around these insulated joints.
2. The DAX relay drive output is connected to the controlled crossing by a two wire line or cable circuit and is normally connected to the UAX input terminals, or the DAX relay drive output must have sufficient pickup delay time programmed if the UAX input is not available. The DAX relay drive output may also be connected through a vital AND-gate where both crossings Y and Z have control of the UAX at crossing X (see Figure 10-2). Radio DAXing may also be used; contact Safetran Application Engineering.
3. Bidirectional simulation should be used to take advantage of the bidirectional operating characteristics when changing ballast conditions are encountered, or other conditions warrant its use.

10.5 PROGRAMMING FOR DAX OPERATION

The 3000 GCP is programmed for DAX operation using the keyboard. DAXing information includes island length, number of DAX's required for crossing control, DAX circuit track assignments, DAX distance, DAX warning time required, and DAX pickup delay time. The DAX operating parameters are programmed as described in the following paragraphs.

10.5.1 Island (Distance)

This parameter is the island length between feed wires for the track. Safetran recommends a minimum island track circuit length of 120 feet and a maximum high frequency island circuit length of 300 feet but not to exceed 30 percent of the longest GCP approach. When there is no island, program the GCP for zero feet.

10.5.2 Number Of DAX's

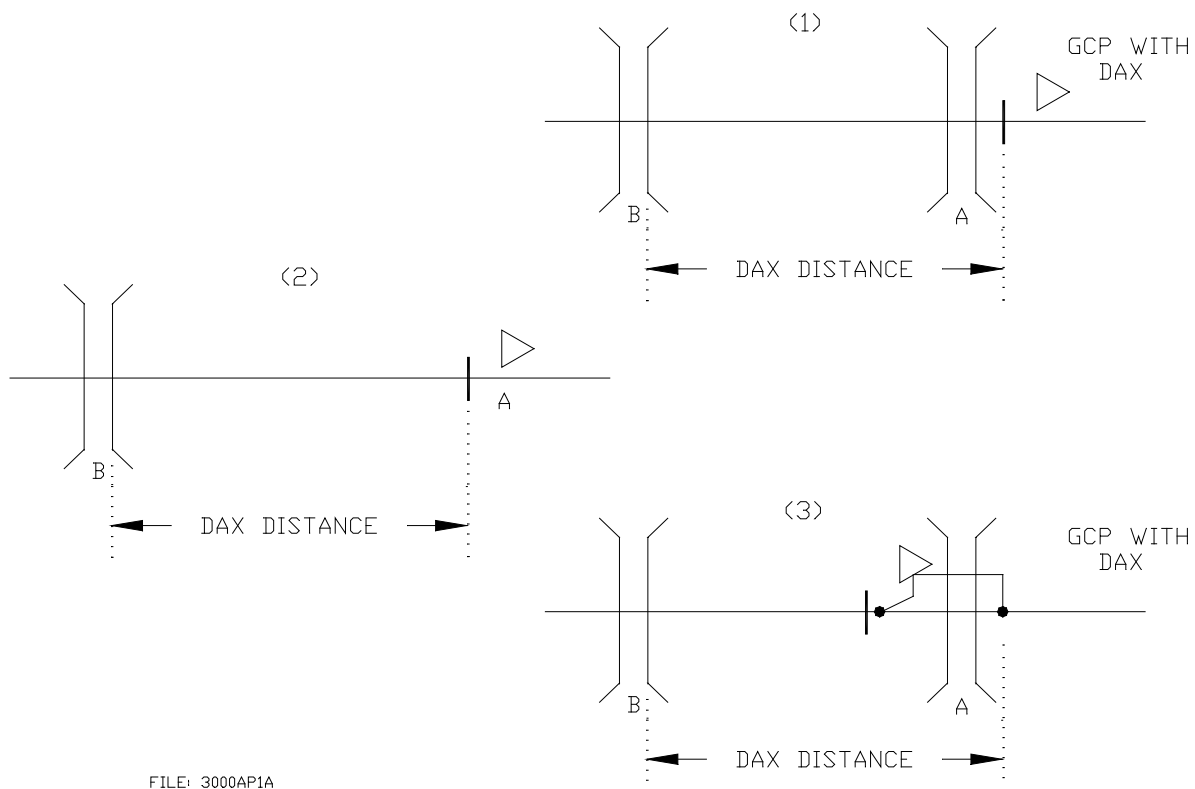
This is the number of DAX circuits used in the GCP unit and numbers 1 to 4 (1 to 8 for 8-DAX units) and 0 (zero) are valid. Two DAX circuits are available on each DAX module. If 0 (zero) is entered, the next menu item to appear is SLAVING. If a number from 1 to 4 (8) is entered, three additional menu items for each DAX selected will follow immediately. The three displays appear sequentially first for DAX A, then DAX B, and so on. The DAX circuit affected is indicated in the top row of the display.

10.5.3 DAX Track (Track Assignment)

This parameter indicates the track assignment (1 or 2) for the associated DAX (A, B, C, etc.). Up to four (eight) DAX's can be assigned.

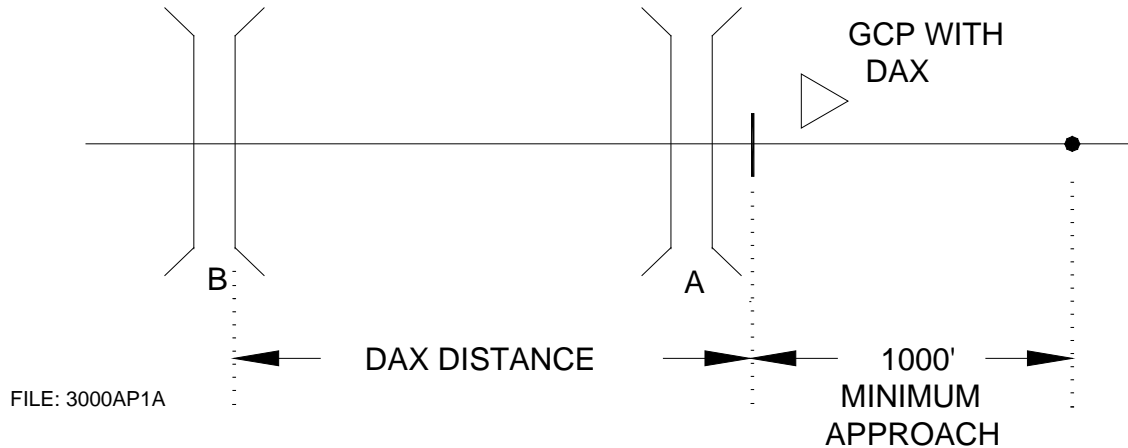
10.5.4 DAX Distance

This entry indicates the approach distance (in feet) between crossings, or between the remote location and the crossing to be DAXed. The distance is measured from the track wire connections at the nearest edge of the street at crossing B to the insulated joints at crossing A (example 1), to the insulated joints at remote location A (example 2), or to the receiver track leads at crossing A when a GCP is "looking" through a street (example 3).



**Figure 10-7:
Determining DAX Distance**

The minimum recommended approach length for a 3000 GCP used for DAXing is 1,000 feet. This distance can consist of actual track length or, when the approach is less than 1,000 feet and the termination shunt is against insulated joints, by a combination of actual track plus simulated track installed at the end of the approach. When required, Simulated Track Inductor, 8V617, or Adjustable Inductor, 8A398-6, is installed in series with the termination shunt located at a set of insulated joints.



**Figure 10-8:
Minimum DAX Distance**

NOTE

NOTE
At DAX locations where an island circuit is not part of the approach circuit and the approach length is less than 1,800 feet, the 3000 GCP receiver track wires should be connected to the rails at a point 50 feet from the transmitter track wires. The transmitter track wires should also be connected to the rails at the insulated joints.
Level (8V980-A01F) GCP software removes the 50-foot distance requirement between receiver and transmitter track leads.

10.5.5 DAX Warning Time

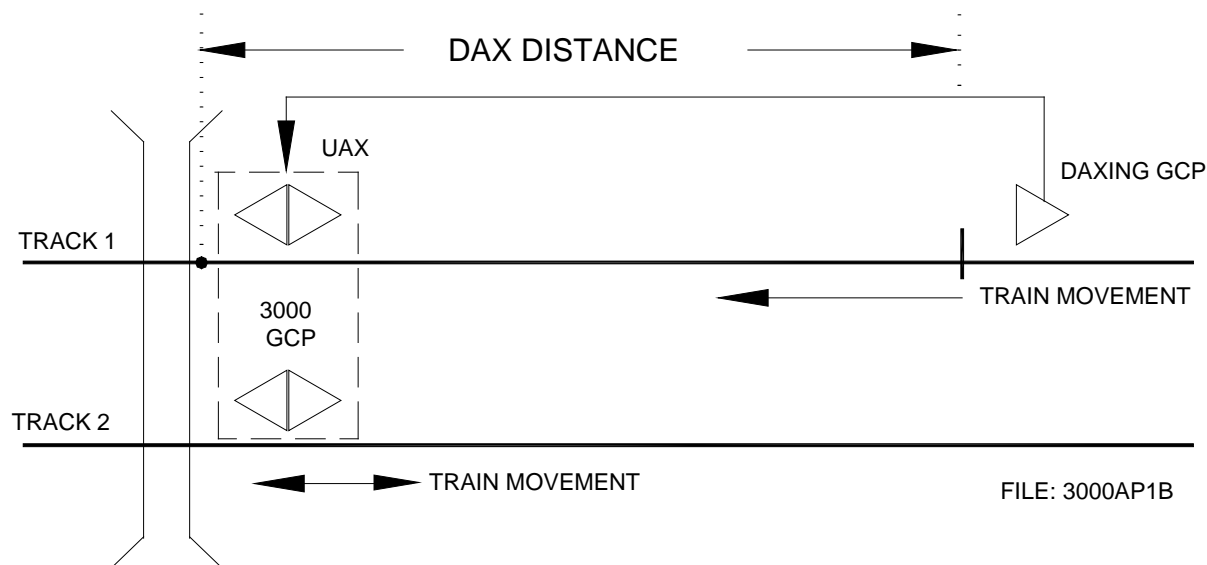
This entry indicates the warning time (in seconds) for the associated DAX. The DAX warning time is generally selected to be the same or up to 5 seconds longer than the prime or crossing warning time. When the indicated DAX is used for the traffic signal preemption function, the preempt warning time is generally selected to be 10 to 15 seconds longer than the prime warning time.

10.5.6 DAX Pickup Delay Time

This programming variable is found in the FUNCTION key menu and has a default value of 15 seconds. However, to ensure that the system is programmed for the optimum pickup delay interval under all operating conditions, the delay interval can be calculated as explained in the following example.

When a Model 3000 GCP equipped with two transceiver modules (80012) is installed on both tracks at a two track crossing, and the GCP at the crossing is controlled from a remote 3000 GCP, program each remote 3000 GCP DAX pickup delay (and prime pickup delay if prime prediction offset is used) as follows:

$$\frac{\text{DAX Distance to The Crossing (feet)}}{\text{Maximum Train Speed (feet per second)}} = \text{DAX Pickup Delay (seconds)}$$



**Figure 10-9:
DAX Pickup Delay**

In the above equation, DAX distance is measured in feet from the remote GCP track receiver feedpoints to the track wires at the nearest edge of the street (see Figure 10-9). Train speed is the maximum speed encountered in feet per second. Each DAX pickup delay must be programmed for a minimum of 8 seconds to a maximum of 20 seconds. If the calculated delay is 21 seconds or longer, program the DAX pickup delay time for 20 seconds. If the calculated delay is less than 8 seconds, program the delay for 8 seconds. If the calculated DAX pickup delay time is between 8 and 20 seconds, program the delay for the calculated time.

WARNING

WARNING

DO NOT PROGRAM DAX PICKUP DELAY TIMES FOR LESS THAN 8 SECONDS.

NOTE

NOTE

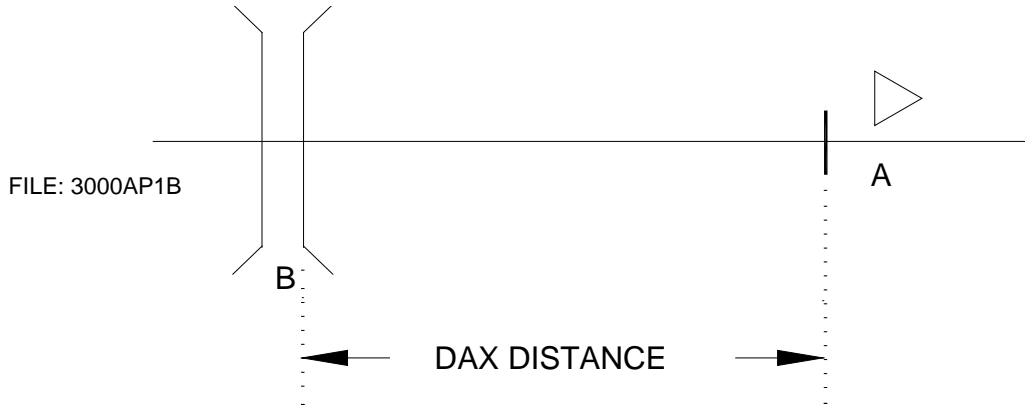
Level (8V980-A01F) GCP software provides the 3000 GCP with separate UAX inputs, one for each transceiver. This removes the requirements stated in the example and WARNING stated above. With Level and later software, DAX pickup delay time becomes less critical.

When the remote DAXing unit is other than a 3000 GCP, or for additional information, contact Safetran Applications Engineering.

10.6 PRIME PREDICTION OFFSET

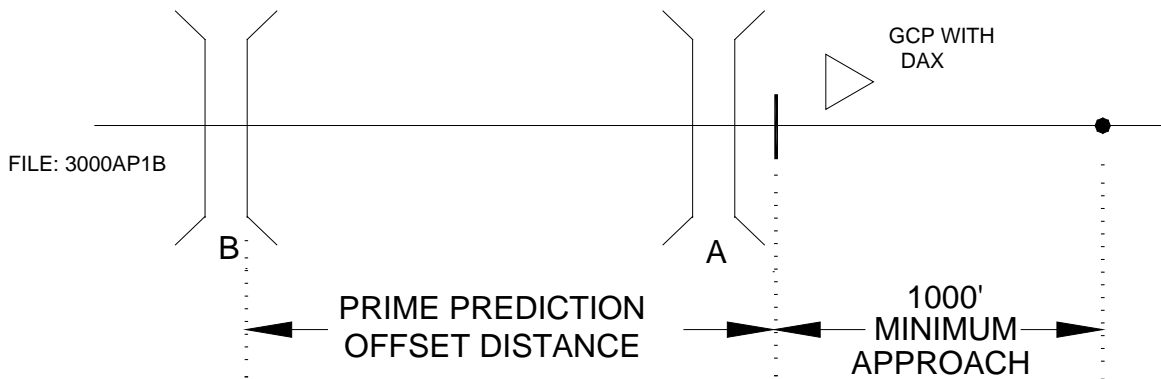
When a single DAX is required from a remote location other than a crossing, the DAX module can be eliminated by using the prime relay drive output. The offset distance to the crossing is programmed into the unit via the keyboard and the GCP relay drive terminals are used to control the UAX at the crossing. The offset distance is entered as described in the following paragraphs.

Programming the prime prediction offset distance in the function menu enables a remote 3000 GCP (track wires not located at a crossing) to provide the equivalent of a single DAX output without the use of a DAX module. By offsetting the prime predictor (similar to DAX offset), the prime is converted to a DAX. The offset distance is measured from the insulated joints at point A to the edge of the street. Both track 1 and track 2 have independent prime prediction offset capabilities.



**Figure 10-10:
Programming Prime Prediction Offset**

The minimum recommended approach length for a 3000 GCP used for prime prediction offset is 1,000 feet. This distance can consist of actual track length or, when the approach is less than 1,000 feet and the termination shunt is against insulated joints, by a combination of actual track plus simulated track installed at the end of the approach. When required, Simulated Track Inductor, 8V617, or Adjustable Inductor, 8A398-6, is installed in series with the termination shunt located at a set of insulated joints.



**Figure 10-11:
Minimum Approach Length with Prime Prediction Offset**

At prime prediction offset locations where an island circuit is not part of the approach circuit and the approach length is less than 1,800 feet, the 3000 GCP receiver track wires should be connected to the rails at a point 50 feet from the transmitter track wires. The transmitter track wires should also be connected to the rails at the insulated joints.

NOTE

NOTE
F-level (8V980-A01F) GCP software removes the 50-foot offset requirement for future installations.

Enter the distance (offset) from the normal zero prediction point to a remote zero prediction point. Valid entries are from 1 to 9999 feet plus 0 (zero), which produces an OFF indication on the display.

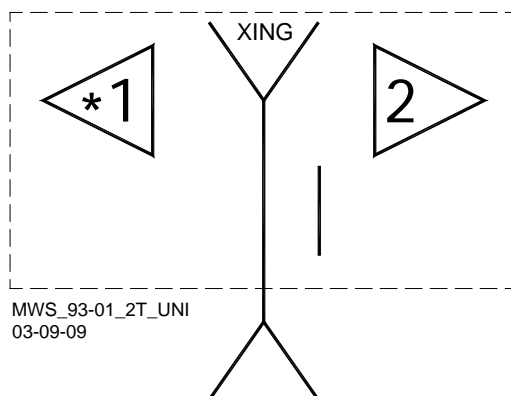


Figure 10-12:
Back-to-Back Model 3000 GCP Application

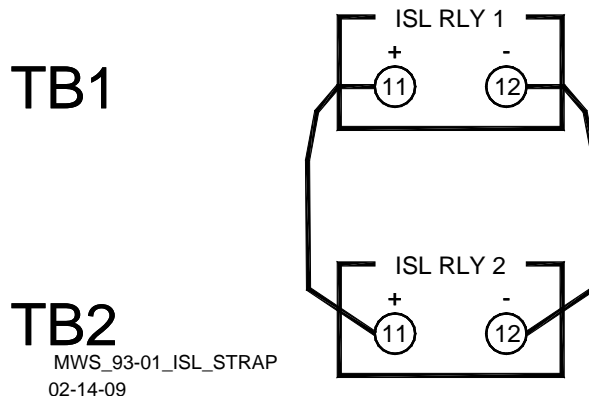


Figure 10-13:
Island Relay Strapping in Back-to-Back Application

NOTE

NOTE
When a GCP is operating in a back to back application as shown in Figure 10-12, proper canceling of the loss-of-shunt timer and proper recording of warning time requires that the Island Relay 1 and Island Relay 2 (+) and (-) terminals must be strapped together as depicted in Figure 10-13.

Since only a single island module is used in the GCP (TI), strapping the island terminals together supplies GCP logic information which enables proper recording of warning time and proper canceling of the time remaining in the T2 loss-of-shunt pickup delay timer.

When two GCPs are operating in a back to back application on double track as shown in Figure 10-14, proper canceling of the loss-of-shunt timers and proper recording of warning times requires that the Island Relay 1 of GCP1 and Island Relay 1 of GCP 2 (+) and (-) terminals must be strapped together. In addition, Island Relay 2 of GCP1 and Island Relay 2 of GCP 2 (+) and (-) terminals must be strapped together as depicted in Figure 10-15.

Strapping the appropriate island terminals together supplies the GCP with logic information which enables proper recording of warning time and proper canceling of the time remaining in the T2 loss-of-shunt pickup delay timers for GCP 2.

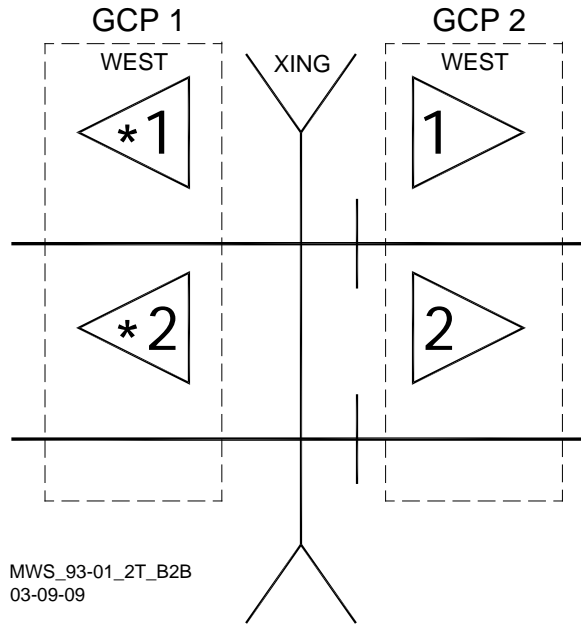


Figure 10-14:
Two GCPs in Back-to-Back Application on Double Track

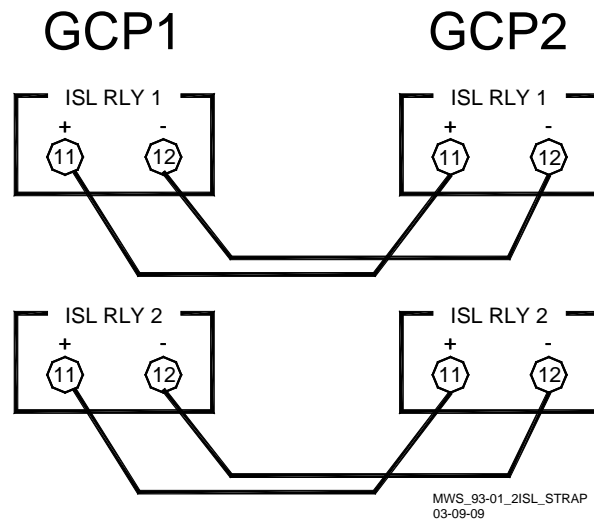


Figure 10-15:
Strapping Island Relays on Two GCPS in
Back-to-Back Application on Double Track

10.7 SPECIAL APPLICATIONS FOR DAX MODULES

Two special applications in which DAX modules are used include traffic signal preemption and when two independent relay drive outputs are desired for track 1 and track 2.

10.7.1 Traffic Signal Preemption (Through Move Train Traffic)

The traffic signal preempt application can be installed as bidirectional, unidirectional, or bidirectional simulation. Traffic signal preemption requires a DAX module (80016) at the crossing. To use the DAX module for a traffic signal preemption application, program the DAX for:

1. Track assignment (1 or 2),
2. DAX distance (zero, which indicates PREEMPT on the display),
3. DAX (preempt) warning time.

All necessary logic for the preempt function is included when the DAX is programmed for preempt. In addition to the preempt warning time control of the preempt relay drive, the preempt relay drive is also deenergized any time the associated island or UAX (when used) is deenergized.

NOTE

NOTE

For GCP 3000 systems equipped with 80214 processors and F-level software or later, refer to Section 4.16.21 of Instructions and Installation Manual. Entering any value from 1 to 9999 disables the preempt function so that the island and UAX do not affect the DAX relay drive.

The 3000 GCP which controls the crossing can be operated as unidirectional, bidirectional, or bidirectional simulation. Approach length must equal the preempt warning time (normally longer than the GCP prime warning time) plus system response time (4 seconds) multiplied by the maximum train speed in feet per second. For example, the approach length required to produce 40 seconds preempt warning time for trains traveling 60 miles per hour is as follows:

$$(40 + 4) \times (60 \times 1.47) = 3,881 \text{ feet}$$

In general, the preempt warning time should be set for 5 seconds longer than the desired preempt time to assure that the preempt time interval (preempt warning time minus prime warning time) is not less than desired. This interval should be confirmed under normal conditions at installation.

10.7.2 Independent Relay Drive Outputs For Track 1 And Track 2

Since a DAX module (80016) supplies two independent relay drive outputs, the outputs can be utilized to provide separate relay drive outputs for track 1 and track 2 (see Figure 10-30). In this configuration, the 3000 GCP is programmed such that one output is assigned to track 1 while the other is assigned to track 2. Both DAX's should be programmed for zero offset distance (preempts). This causes one or the other DAX to predict simultaneously with the prime MS/GCP, except that each predicts for a separate track. The DAX warning time and pickup delays should be programmed the same as the basic prime MS/GCP (if it were being used). The MS/GCP relay drive output is normally not used in this application.

The two DAX relay drive outputs can be connected to independent relays which, in turn, control the XR, or they can be "ANDed" by a solid-state vital AND gate (90975), which then controls the XR or a solid-state crossing controller. The independent relay drive outputs also permit the use of wraparounds, independent monitoring of track 1 and track 2 in an event recorder, and/or provide a simple method of removing either track from service during maintenance operations.

10.8 OS TRACK CIRCUITS

When an OS (Occupied Switch) track circuit is located within a 3000 GCP approach, the application design can be extremely complex, depending upon the following conditions:

1. The proximity of the crossing to the OS track circuit,
2. The side of the crossing in which the OS track circuit is located,
3. Whether the OS track circuit is located within a crossing, and

4. Maximum train speeds encountered through the OS track circuit.

The OS track circuit must be reviewed, especially for use of series OS circuits, to ensure compatibility with GCP operation. Contact Safetran Application Engineering for assistance.

The OS track circuit should be formed using two DC track circuits energizing relays that are controlled by a battery at the switch point end of the circuit and relays at the fouling ends. A repeater relay circuit is then formed to interface with the signal control circuits.

Independent track batteries may also be used to power the individual track circuits, in which case it may be necessary to use wideband shunts to couple the GCP operating frequency around insulated joints in the turnout.

When a GCP is installed within the limits of an existing series OS circuit, the OS circuit should be converted to a parallel or two relay circuit since installation of inductors in series OS track circuits has frequently resulted in marginal operation. Safetran recommends use of the two relay or parallel relay circuit. See Figure 10-16 and Figure 10-18 for typical GCP and OST installation diagrams.

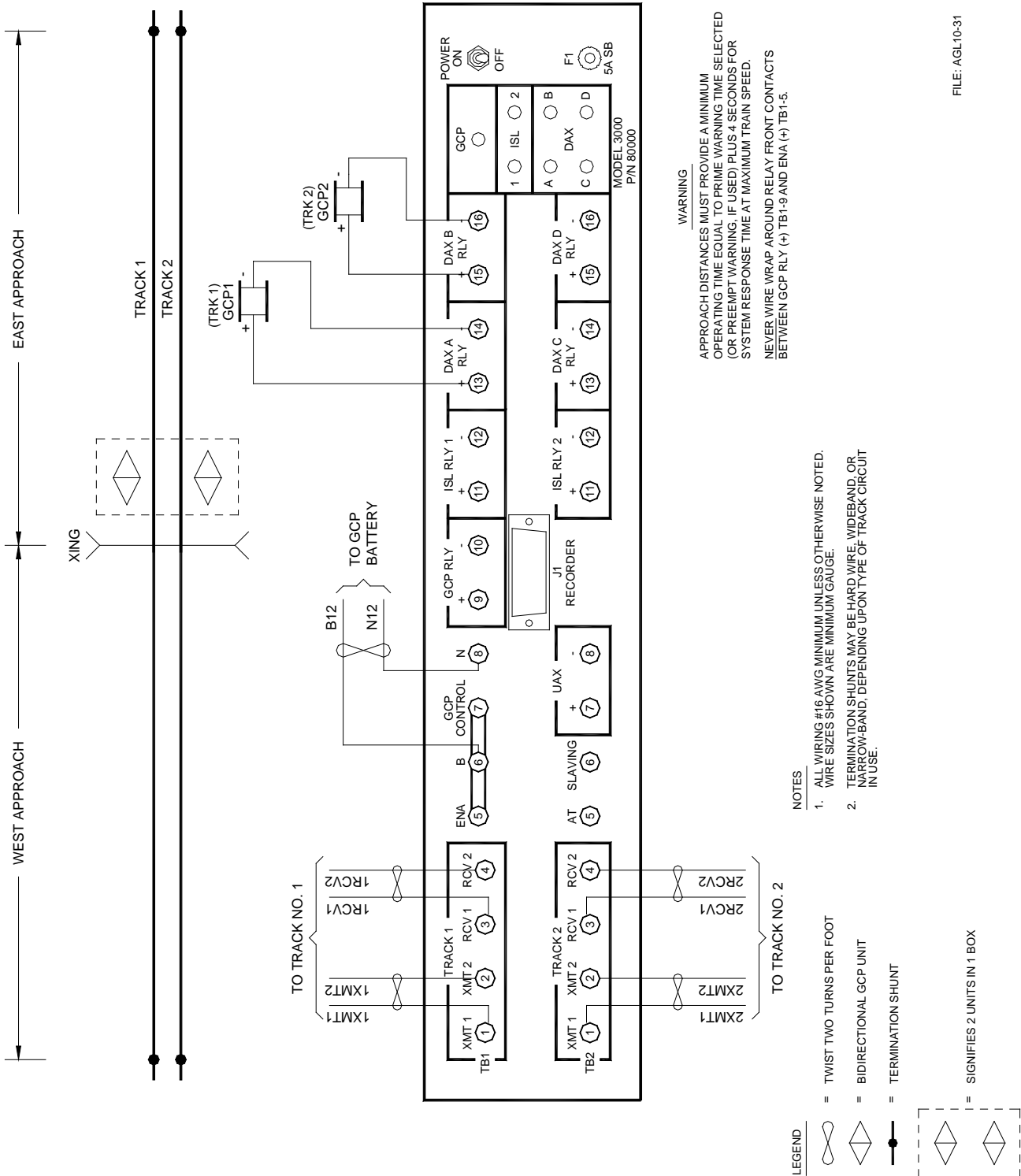


Figure 10-16:
Typical Bidirectional Two-Track Application With Independent GCP Outputs

3000 GCP APPLICATION DESIGN CARD

Designer: _____ Date: _____
 Equipment: 3000 3000D2 3000ND2 Crossing No: _____
 Crossing Name: _____ City: _____ State: _____
 Island Frequency: T1: 4.0 kHz T2: 4.9 kHz

NUMBER OF TRACKS (Number of Transceiver Modules, 1 or 2)	1 <input type="checkbox"/> 2 <input checked="" type="checkbox"/>
FREQUENCY (MS/GCP)	<u>156</u> Hz
UNIDIRECTIONAL/BIDIRECTIONAL	T1: UNI <input type="checkbox"/> BI <input checked="" type="checkbox"/> T2: UNI <input type="checkbox"/> BI <input checked="" type="checkbox"/>
XMIT LEVEL	T1: HI <input type="checkbox"/> MED <input checked="" type="checkbox"/> LOW <input type="checkbox"/> T2: HI <input type="checkbox"/> MED <input checked="" type="checkbox"/> LOW <input type="checkbox"/>
PREDICTOR/MOTION SENSOR	T1: PRED <input checked="" type="checkbox"/> MS <input type="checkbox"/> T2: PRED <input checked="" type="checkbox"/> MS <input type="checkbox"/>
WARNING TIME SELECTED	T1: <u>N/A</u> Sec. T2: <u>N/A</u> Sec.
APPROACH DISTANCE SELECTED	T1: <u>3000</u> Ft. T2: <u>3000</u> Ft.
APPROACH DISTANCE COMPUTED	T1: Calculated by software* T2: Calculated by software*
UAX1 PICKUP DELAY (0 = OFF)	<u>0</u> Sec.
ENA/UAX2 PICKUP DELAY (0 = ENA **)	ENA <input checked="" type="checkbox"/> UAX2 <input type="checkbox"/> <u>0</u> Sec.
ISLAND DISTANCE (Between Feed Wires)	T1: <u>120</u> Ft. T2: <u>120</u> Ft.
NUMBER OF DAXS	0 <input type="checkbox"/> 1 <input type="checkbox"/> 2 <input checked="" type="checkbox"/> 3 <input type="checkbox"/> 4 <input type="checkbox"/>
DAX A TRACK ASSIGNMENT	T1: <input checked="" type="checkbox"/> T2: <input type="checkbox"/>
DAX A DISTANCE (0 = Preempt)	<u>0</u> Ft.
DAX A WARNING TIME	<u>30</u> Sec.
DAX B TRACK ASSIGNMENT	T1: <input type="checkbox"/> T2: <input checked="" type="checkbox"/>
DAX B DISTANCE (0 = Preempt)	<u>0</u> Ft.
DAX B WARNING TIME	<u>30</u> Sec.
DAX C TRACK ASSIGNMENT	T1: <input type="checkbox"/> T2: <input type="checkbox"/>

FILE: AGL10-32

*Programmed at installation during calibration procedure
 **When set to 0, strap ENA terminal to B+ terminal.

3000 GCP APPLICATION DESIGN CARD (Continued)

DAX C DISTANCE (0 = Preempt)	_____ Ft.
DAX C WARNING TIME	_____ Sec.
DAX D TRACK ASSIGNMENT	T1: <input type="checkbox"/> T2: <input type="checkbox"/>
DAX D DISTANCE (0 = Preempt)	_____ Ft.
DAX D WARNING TIME	_____ Sec.
SLAVING MASTER/SLAVE	MASTER <input checked="" type="checkbox"/> SLAVE <input type="checkbox"/>
PASSWORD ENABLED	DISABLED <input checked="" type="checkbox"/> ENABLED <input type="checkbox"/>
RECORDER INSTALLED	NOT INSTALLED <input type="checkbox"/> INSTALLED <input type="checkbox"/>
RS-232-C BAUD RATE	_____ BPS
RS-232-C DATA BITS	7 <input type="checkbox"/> 8 <input type="checkbox"/>
RS-232-C STOP BITS	1 <input type="checkbox"/> 2 <input type="checkbox"/>
RS-232-C PARITY	NONE <input type="checkbox"/> MARK <input type="checkbox"/> ODD <input type="checkbox"/> SPACE <input type="checkbox"/> EVEN <input type="checkbox"/>
DATE (e.g., MON 16 NOV 1987)	Not Required*
TIME (e.g., 11:25:43 AM)	Not Required*
DAYLIGHT SAVINGS	ON <input type="checkbox"/> OFF <input type="checkbox"/>

EXPANDED PROGRAMMING DESIGN

SWITCH TO MS (Enter EZ Value)	T1: _____ EZ T2: _____ EZ
TRANSFER DELAY MS TO GCP (0 = OFF)	T1: _____ Sec. T2: _____ Sec.
PRIME PREDICTION OFFSET (0 = OFF)	T1: <u>9999</u> Ft. T2: <u>9999</u> Ft.
PICKUP DELAY PRIME	_____ Sec.
PICKUP DELAY DAX A	<u>15</u> Sec.
PICKUP DELAY DAX B	<u>15</u> Sec.
PICKUP DELAY DAX C	_____ Sec.
PICKUP DELAY DAX D	_____ Sec.
COMPENSATION VALUE	T1: Not Required* **
COMPENSATION VALUE	T2: Not Required* **

***The compensation value is provided by the 3000 GCP system and no additional programming is normally required.

Figure 10-17:
Typical Programming Data for Bidirectional Two-Track Application with Independent GCP Outputs

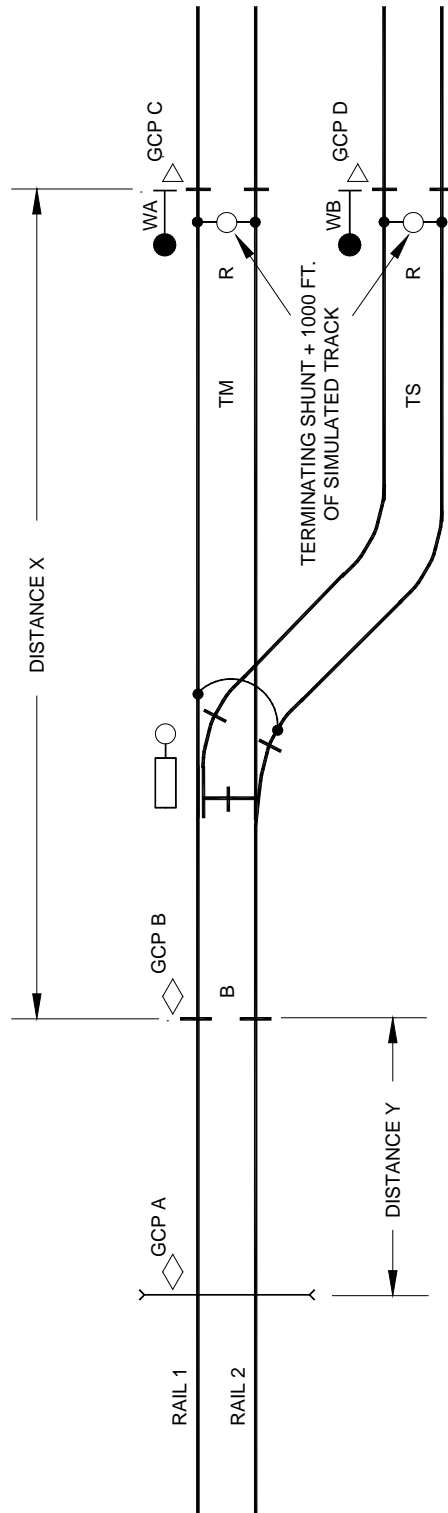


Figure 10-18:
Typical Model 3000 GCP Application In An OS Track Circuit

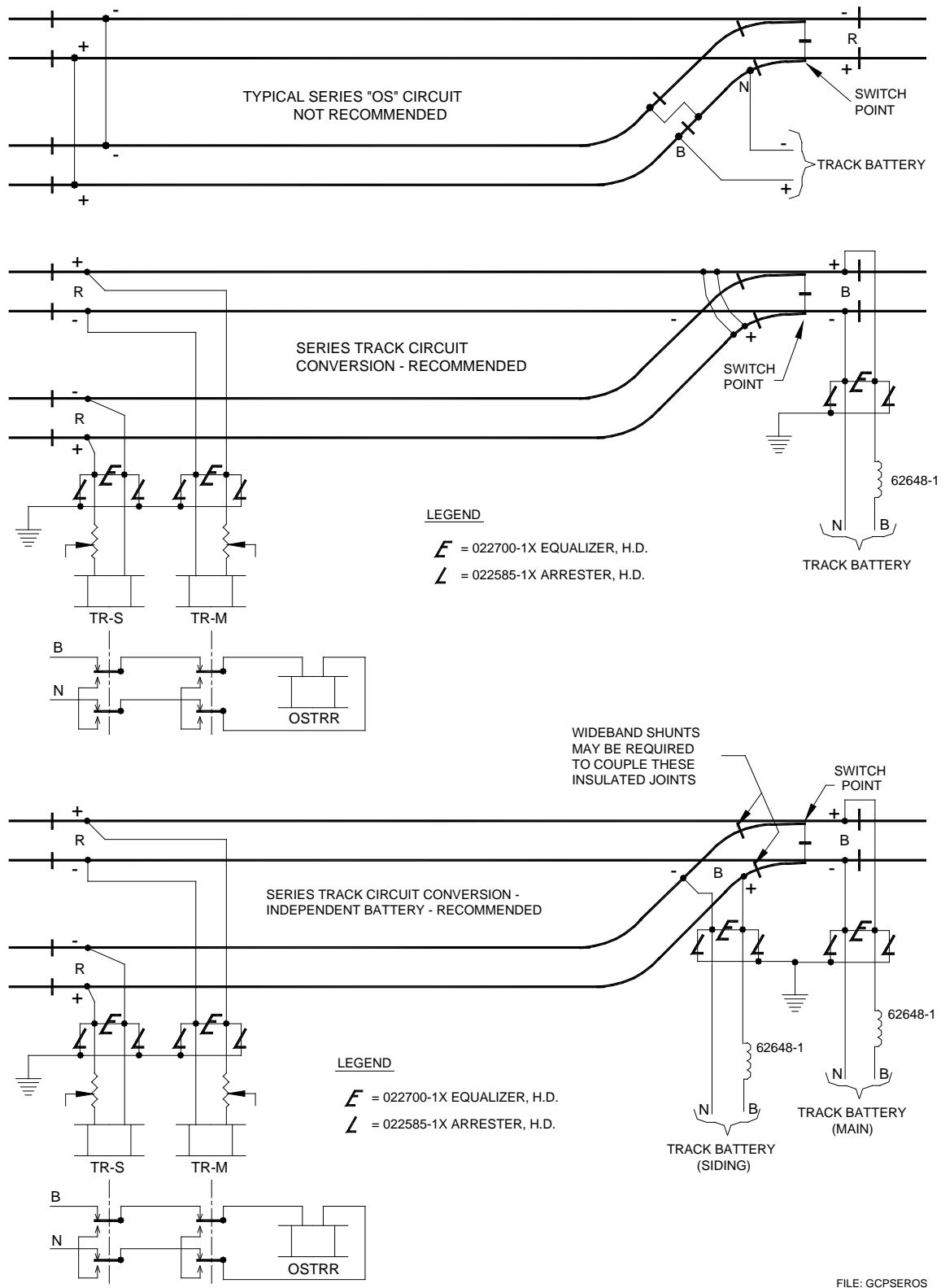


Figure 10-19:
Series Track Circuit Conversion for Motion Sensor Operation

10.9 COMMON UAX APPLICATION GUIDELINES

WARNING

WARNING

WHEN THE UAX1 FEATURE IS PROGRAMMED TO OFF (ZERO TIME ENTERED), THE UAX TERMINALS (UAX 1) AT TB2-7 & TB2-8 ON THE MODEL 3000 GCP FRONT PANEL HAVE NO CONTROL OVER THE MS/GCP RELAY DRIVE OUTPUT. WHEN THE UAX1 FEATURE IS PROGRAMMED BETWEEN 1 AND 500 AND A NOMINAL 12 VOLTS IS REMOVED FROM THE UAX TERMINALS, THE MS/GCP RELAY OUTPUT IS IMMEDIATELY DEENERGIZED. WHEN 12 VOLTS IS REAPPLIED TO THE UAX TERMINALS, THE MS/GCP RELAY DRIVE ENERGIZES AFTER THE UAX1 PICKUP DELAY TIME HAS ELAPSED (PROVIDING NO OTHER CONDITION KEEPS THE MS/GCP RELAY DRIVE DEENERGIZED).

WHEN THE ENA/UAX2 FEATURE IS NOT USED, UNLIKE UAX1, THE ENA TERMINAL TB1-5 MUST BE STRAPPED TO BATTERY B AT TERMINAL TB1-6 ON THE 3000 FRONT PANEL AND THUS WILL HAVE NO CONTROL OVER THE MS/GCP RELAY DRIVE OUTPUT. WHEN THE UAX2 FEATURE IS PROGRAMMED BETWEEN 1 AND 500 AND A NOMINAL 12 VOLTS IS REMOVED FROM THE ENA (UAX2) TERMINAL, THE MS/GCP RELAY OUTPUT IS IMMEDIATELY DEENERGIZED. WHEN 12 VOLTS IS REAPPLIED TO THE UAX2 TERMINAL, THE MS/GCP RELAY DRIVE ENERGIZES AFTER THE UAX2 PICKUP DELAY TIME HAS ELAPSED (PROVIDING NO OTHER CONDITION KEEPS THE MS/GCP RELAY DRIVE DEENERGIZED).

10.9.1 Turning off the UAX1 and ENA/UAX2 functions

CAUTION

CAUTION

READ THE FOLLOWING APPLICATION INFORMATION CAREFULLY IN 10.9.1, 10.9.2, AND 10.9.3 TO ENSURE APPLICATION PROGRAMING COMPLIANCE PRIOR TO PLACING THIS EQUIPMENT IN SERVICE..

When the UAX 1 input is not used, program UAX 1 to zero (0) time. This deactivates the function, which permits recovery of the MS/GCP Relay Drive. No external Battery connections are required on the UAX front panel terminals when programmed to zero.

When the ENA/UAX 2 input is not used, the ENA terminal must be strapped to battery B by connecting the ENA/UAX2 terminal (TB1-5) to the B terminal (TB1-6), which deactivates the function and permits recovery of the MS/GCP Relay Drive.

10.9.2 UAX1 and ENA/UAX2 input control of T1 and T2

The UAX terminals on the front panel are used for external control of the track 1 section of the 3000 GCP and only the track 1 island circuit, upon pickup, will cancel any UAX 1 time remaining as the train leaves the island circuit. The UAX1 pickup time is a programmable entry.

The ENA/UAX 2 terminal provides a UAX2 input to the track 2 section of the GCP. When the UAX2/ENA function is programmed for zero (0) seconds of pickup delay, the function changes from a UAX2 into an ENABLE input. The enable input controls both Track 1 and Track 2 sections of the GCP and has no pickup delay when the ENA is energized. When the ENA/UAX2 is programmed for a pickup delay other than 0, it changes to a UAX2 function and controls only the track 2 section of the 3000 GCP. Only the track 2 island (upon energizing) will cancel any UAX 2 time remaining when a train leaves its associated island circuit.

10.9.3 Rules Regarding De-energizing Relay Drive Outputs Using Inputs UAX1, UAX2 and ENA.

There are up to five relay drive outputs available in the GCP 3000: GCP, DAX A, DAX B, DAX C and DAX D. The rules governing de-energizing of relay drive outputs are as follows:

1. GCP Relay: This output is a combination of T1 and T2 prime predictors. When de-energized, either or both predictors will cause the GCP output to de-energize. The GCP output will also de-energize whenever the UAX1, ENABLE or UAX2 is deenergized. The GCP Relay will drop out if the prime prediction offset is used.

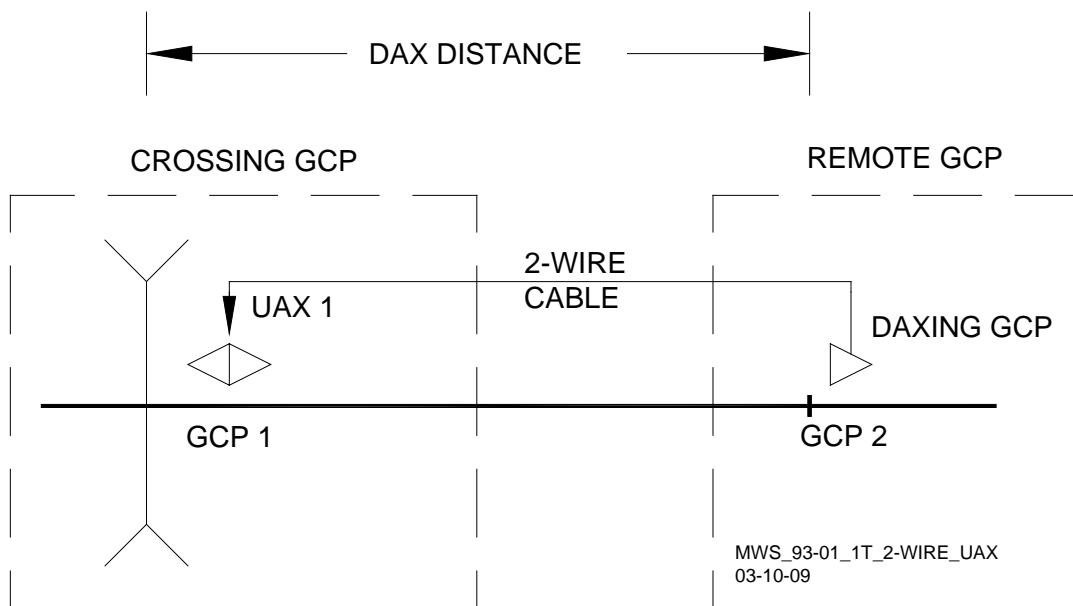
NOTE	NOTE: The UAX1, UAX2 and ENA functions will de-energize only certain DAX relay drive outputs depending on the programmed DAX offset distance and which track (T1 or T2) the DAXes are assigned.
-------------	---

2. DAX A, DAX B, DAX C, or DAX D Relays: When any DAX is used and is programmed with an offset distance greater than zero, it will NOT de-energize when UAX1, ENABLE or UAX2 deenergizes.
3. DAX A, DAX B, DAX C, or DAX D Relays: When a DAX is programmed with a zero (0) offset distance (Preempt) and is assigned to T1, then only UAX1 or ENABLE when deenergized will de-energize that DAX (preempt) output. When a DAX is programmed with a zero (0) offset distance (Preempt) and is assigned to T2, then only UAX2 or ENABLE when deenergized will de-energize that DAX (preempt) output.

10.9.4 Single Track UAX and ENA Applications

The following three single track/DAX applications (paragraphs 10.9.4.1, 10.9.4.2, and 10.9.4.3) provide a review of the basic UAX/ENA/DAX pickup delay programming requirements.

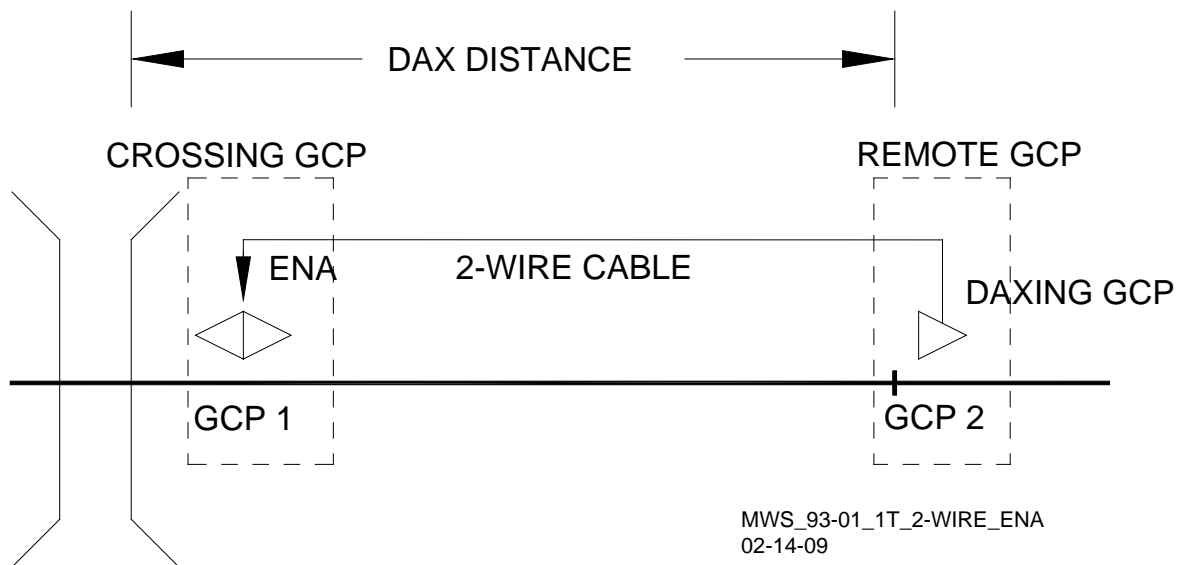
10.9.4.1 Single Track Using Separate GCPs with Active UAX Controlled from a Remote Location



**Figure 10-20:
DAX Programming Requirements (Single Track,
Dual GCP, UAX Controlled From Remote Location)**

1. Program UAX 1 (GCP 1) for 25 seconds.
2. Connect GCP battery B to ENA/UAX 2 Terminal.
3. Program the DAX pickup delay time at the remote location (GCP 2) for 15 seconds, or to the value presently programmed if longer.
4. If prime prediction offset is used at the remote DAX (GCP 2), program the remote prime pickup delay time for 15 seconds or to the value presently programmed if longer.

10.9.4.2 Single Track Using Separate GCPs with Active ENA Controlled from a Remote Location



**Figure 10-21:
DAX Programming Requirements (Single Track,
Dual GCP, ENA Controlled From Remote Location)**

WARNING	WARNING
	<p>IF THE REMOTE DAX (GCP 2) IS OTHER THAN A 3000/4000 GCP (A MODEL 660, 400, HXP, ETC.), THE ENABLE INPUT <u>CANNOT</u> BE USED. THE UAX INPUT AND ITS ASSOCIATED PROGRAMING MUST BE USED AS ILLUSTRATED AND DISCUSSED IN PARAGRAPH 10.9.4 ABOVE.</p>

NOTE	NOTE
	<p>Some applications use the ENA (Enable) input instead of the UAX input for crossing control from a remote 3000 GCP DAX. When programming the 3000 GCP to utilize the ENA functionality, the pickup delay is set to zero (0); therefore all required pickup delay time must be provided by the DAX pickup delay (either Model 3000 or 4000 GCP). The actual DAX pickup delay for through-move trains, when in AUTO mode, is automatically computed to recover shortly after a train arrives at the street.</p>

1. Program ENA/UAX2 (GCP 1) for zero (0) time (to activate the Enable function).
2. Since the UAX input is not used (no wires connected to the UAX terminals), program UAX 1 for 0 (zero) time.
3. Program the DAX pickup delay time at the remote location (GCP 2) for 15 seconds, or to the value presently programmed if longer.
4. If prime prediction offset is used at the remote DAX (GCP 2), program the remote prime pickup delay time for 15 seconds or to the value presently programmed if longer.

10.9.4.3 Single Track using Single GCP (No UAX or Enable Used)

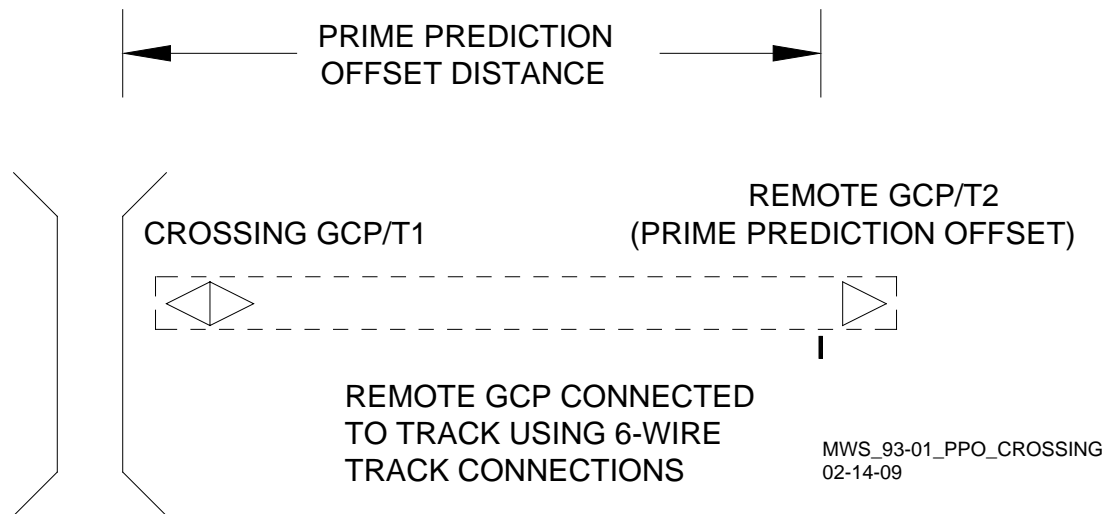


Figure 10-22:
**DAX Programming Requirements (Single Track,
 Crossing and Remote GCPs (T1 and T2) in Same GCP Case)**

1. Since the UAX is not required, program UAX 1 for zero (0) time (off).
2. Connect GCP Battery B to ENA/UAX 2 terminal.
3. Program the prime pickup delay time of T2 in the Function menu for 15 seconds or to the value presently programmed if longer.

10.9.5 Double Track UAX/ENA Applications

In double track applications with remote DAX control, important differences exist when programming the UAX/ENA/DAX pickup delays. These programming differences must be carefully reviewed before placing the crossing in operation. The programming differences are necessary to allow for:

- Proper canceling of any remaining pickup delay time in UAX 1 or UAX 2 timers as a fast-moving, short train leaves the island circuit
- Accurate recording of crossing warning times in History and the data recorder when the crossing is started from remote DAX's.

The double track/DAX application figures provided in paragraphs 10.9.5.1 (see Figure 10-23 and Figure 10-24), 10.9.5.2 (see Figure 10-25), and 10.9.5.3 (see Figure 10-26 and Figure 10-27) that follow provide the UAX/ENA/DAX pickup delay requirements.

10.9.5.1 Double Track Installations with Active UAX from a Remote DAX Location



WARNING

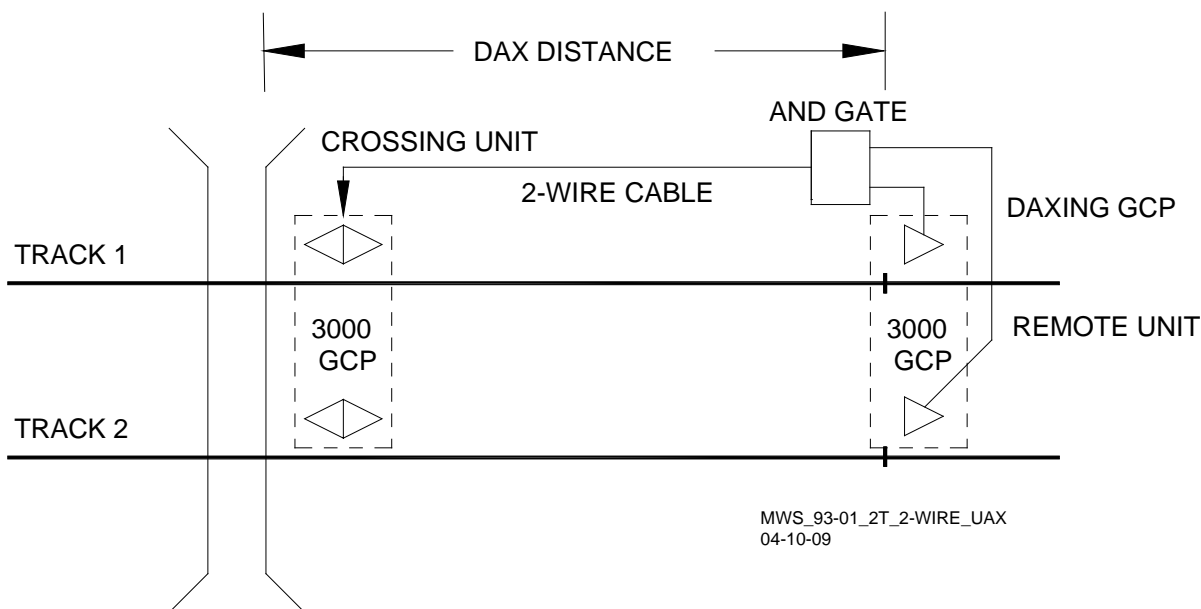
IF THE REMOTE DAXING GCP'S ARE OTHER THAN 3000/4000 GCP'S (MODEL 660, 400, HXP, ETC.), THIS APPLICATION CANNOT BE USED. INDEPENDENT UAX CONTROLS AND THEIR PROGRAMING APPLICATION MUST BE USED AS ILLUSTRATED AND DISCUSSED IN PARAGRAPH 10.9.5.

IF THE ENA (ENABLE) TERMINAL IS ALREADY WIRED FOR DAXES FROM ANOTHER REMOTE GCP OR OTHER CROSSING CONTROL CIRCUIT, ENA WIRING MUST BE APPLIED DIFFERENTLY. CONTACT SAFETRAN APPLICATION ENGINEERING FOR SPECIFIC INSTRUCTIONS.

NOTE**NOTE**

The actual DAX pickup delay for through-move trains is automatically computed to recover shortly after a train arrives at the street.

To accurately record crossing warning times when a GCP is operating as shown in Figure 10-23, the UAX 1 and ENA/UAX 2 terminals must be strapped together as shown in Figure 10-24 and each both functions are programmed to 1 second.



**Figure 10-23:
DAX Programming Requirements (Double Track, Dual GCPs,
Active UAX From a Remote DAX Location Via AND Gate)**

1. Program UAX 1 in GCP 1 for one (1) second.
2. Set each DAX pickup delay time (T1DAX A and T2DAX B) at the remote DAX location for 15 seconds, or to the value presently programmed if longer. If prime prediction offset is used instead of the DAXes at the remote location, program each remote prime pickup delay for 15 seconds or to the value presently programmed if longer. In addition, if prime predictors are used at the remote (prime prediction offset) then the AND gate is not required and use the GCP output terminals (Note: T1 prime and T2 prime are already internally ANDed).
3. Strap UAX 1 and ENA/UAX 2 in parallel as shown in Figure 10-24.
4. Program ENA/UAX2 for one (1) second. Ensure ENA terminal is not strapped to battery B.

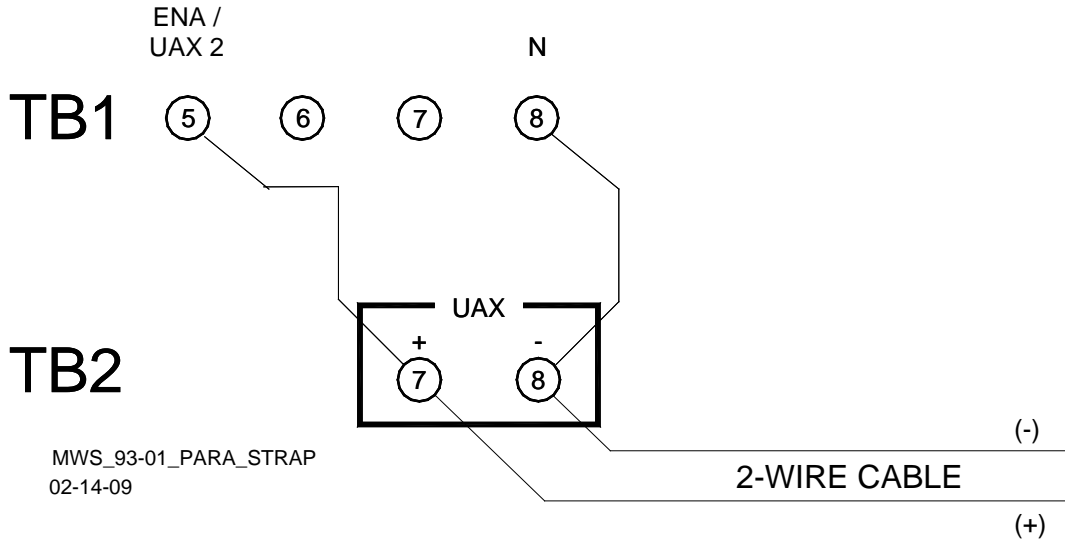


Figure 10-24:
UAX 1 (TB2-7 & TB2-8) Wired in Parallel
to UAX/ENA 2 (TB1-5) and N (TB1-8)

10.9.5.2 Double Track Installations with Active ENA from a Remote DAX location

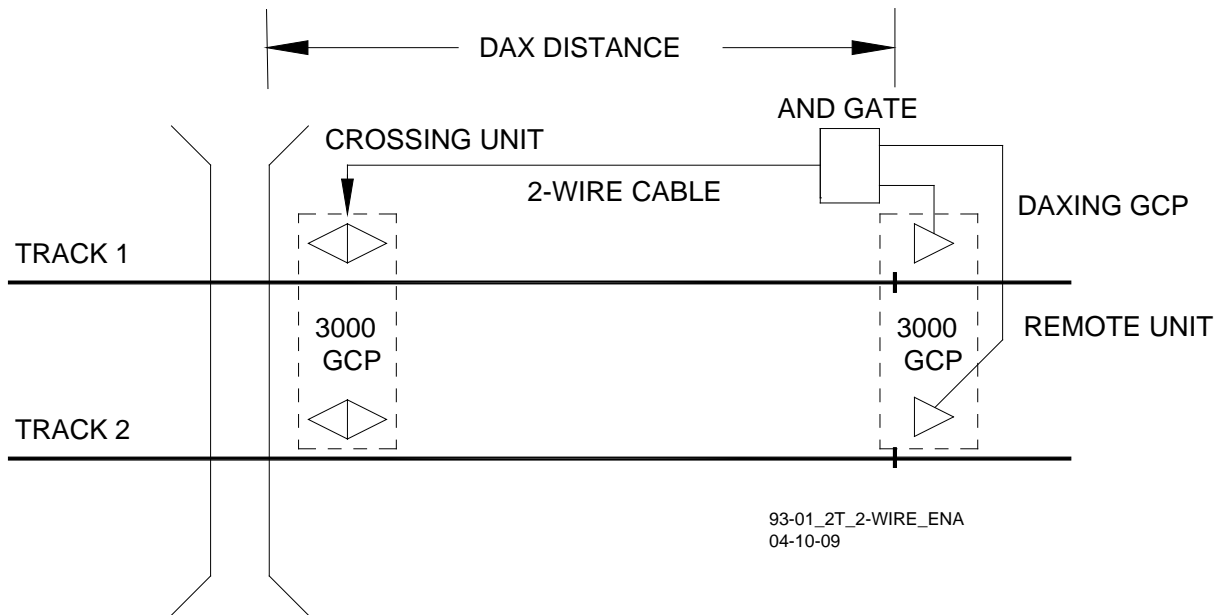


Figure 10-25:
DAX Programming Requirements (Double Track, Dual GCPs,
Active ENA From a Remote DAX Location Via AND Gate)

WARNING

WARNING

IF THE REMOTE DAXING GCP'S ARE OTHER THAN 3000/4000 GCP'S (MODEL 660, 400, HXP, ETC.), THIS APPLICATION **CANNOT** BE USED. INDEPENDENT UAX CONTROLS AND THEIR PROGRAMMING APPLICATION, MUST OR USED AS ILLUSTRATED AND DISCUSSED IN PARAGRAPH 10.9.5.3.

1. Program ENA/UAX 2 for zero (0) time (activates Enable operation for both tracks). Ensure ENA terminal is not strapped to battery B.
2. Set the DAX pickup delay times at the remote DAX location for 15 seconds, or to the value presently programmed if longer. At the remote predictor, program DAX A to T1 and DAX B to T2.
3. If prime prediction offset is used at the remote DAXes, program the remote prime pickup delays for 15 seconds or to the value presently programmed if longer. In addition, if prime predictors are used at the remote (prime prediction offset) then the AND GATE is not required so use the GCP output terminals (Note: T1 prime and T2 prime are already internally ANDed).

NOTE

NOTE

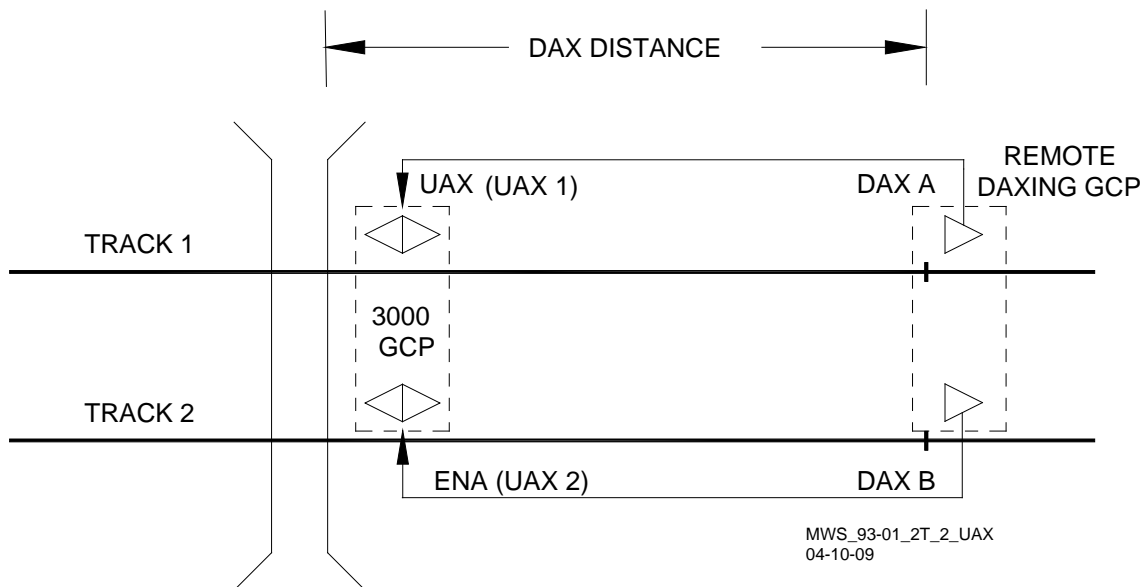
The actual DAX pickup delay for through-move trains is automatically computed to recover shortly after a train arrives at the street.

NOTE

The actual DAX pickup delay for through-move trains is automatically computed to recover shortly after a train arrives at the street.

4. Since the UAX input is not used (no wires connected to the UAX terminals), program UAX 1 for zero (0) time (OFF).

10.9.5.3 Double Track Installations with Independent UAX Controls for Each Track



**Figure 10-26:
DAX Programming Requirements (Double Track,
Dual GCPs, Independent UAX For Each Track)**

NOTE

NOTE
The remote DAX's may be any model GCP (3000, 4000, 660, 400, HXP, etc.) when independent UAX 1 and Enable/UAX 2 inputs are used for track 1 and track 2, respectively.

For new crossing designs where separate UAX two-wire circuits for track 1 and track 2 are used (see Figure 10-26), or where an existing installation is to be converted to separate two-wire UAX circuits, program the GCP as follows:

1. Program UAX 1 for 25 seconds.
2. Program ENA/UAX 2 for 25 seconds.
3. Use T1DAX A and T2 DAX B for remote predictors. Program each DAX pickup delay times for track 1 and track 2 at the remote location for 15 seconds, or to the value presently programmed if longer.

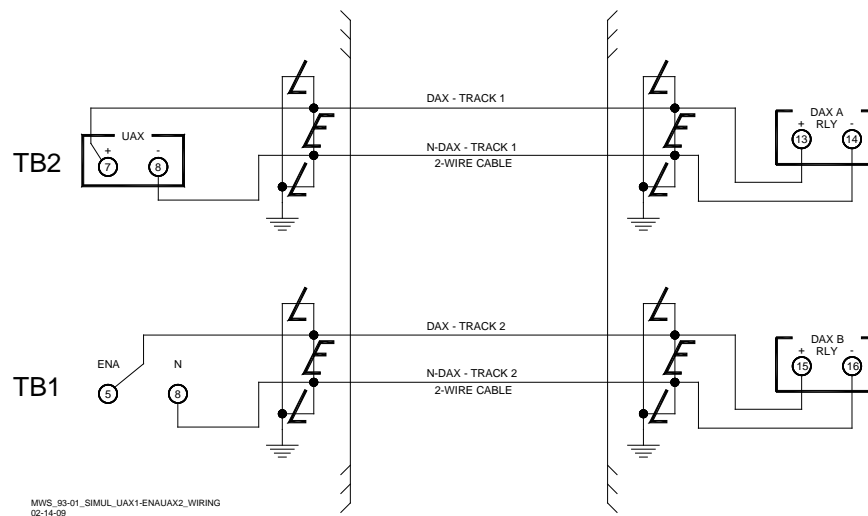


Figure 10-27:
Typical Simultaneous UAX 1 and ENA/UAX 2 Wiring Diagram

10.10 ENABLE (ENA) APPLICATION PROGRAMMING

NOTE

The following applications in paragraphs 10.10.1 and 10.10.2 are based upon all units being Model 3000 family GCPs.

10.10.1 Use of ENA Terminal for Cascading Multiple GCP Units at the Crossing

Cascading using the “ENABLE” function allows for two or more GCP Cases in single or multiple track applications at a crossing to provide a single GCP RLY output to the XR. This GCP RLY output combines all prime predictors together (ANDed) of multiple GCP cases to provide a single XR control. It also provides an accurate recording of crossing warning times in the GCP History and the Data Recorder.

As an example, Figure 10-28 is a double track installation with back-to-back GCP units. GCP1 has the (+) GCP RLY output terminal (TB1-9) wired to GCP2 ENA/UAX2 terminal (TB1-5) and its (-) output wired to the Battery N terminal (TB1-8) of GCP2. The GCP2 ENA/UAX2 terminal is programmed to 0 (zero) pickup delay (ENABLE function). Whenever T1 or T2 prime predictors predicts in GCP1, the GCP2 Enable de-energizes and causes both T1 and T2 prime predictors on GCP2 to de-energize and drop the GCP RLY of GCP2. The ENABLE is used (instead of UAX1 or UAX2) because when de-energized, it starts the warning time timers in GCP2 for both T1 and T2, thus producing accurate warning times for train moves either track.

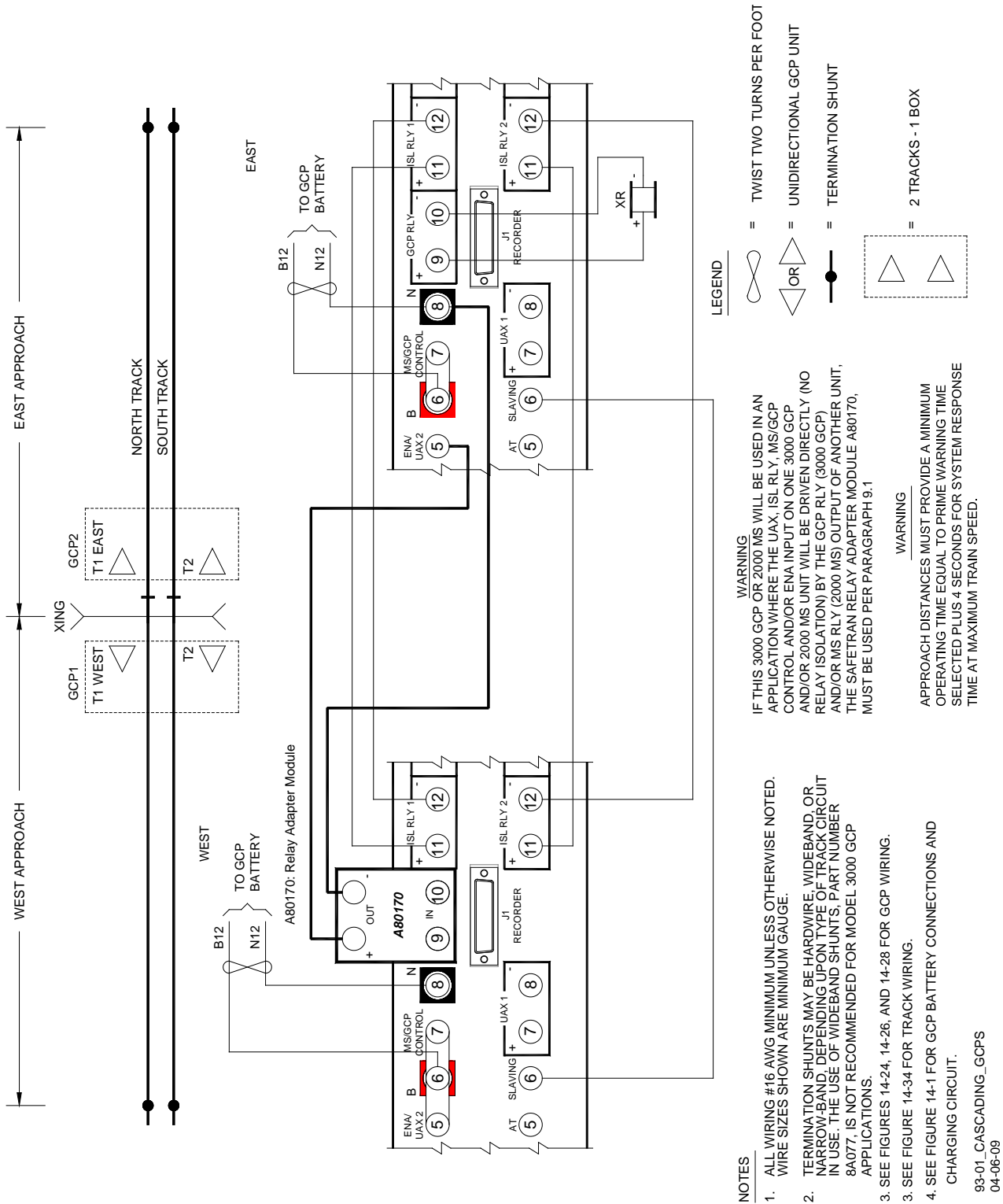


Figure 10-28:
Model 3000/3000D2 GCP Typical Unidirectional Application
with Frequency Slaving and Cascaded Relay Drives, Two Tracks

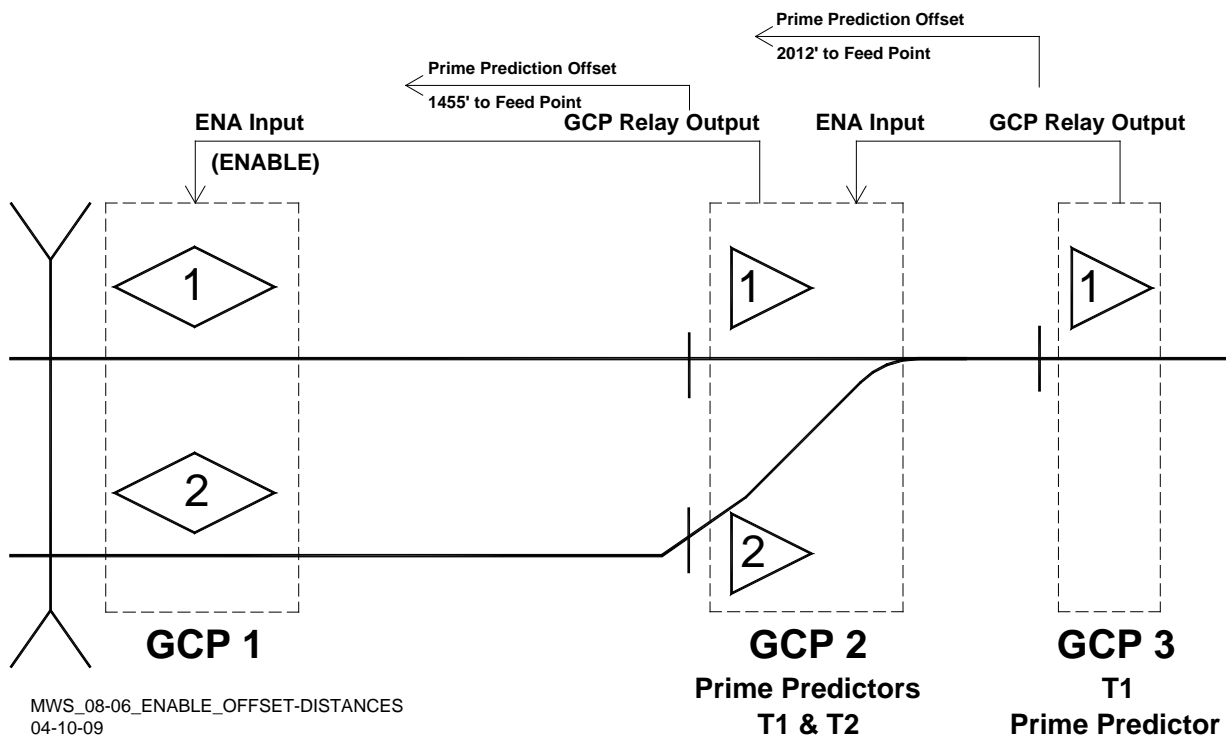
10.10.2 Use of ENA (ENABLE) for Cascading Remote Predictors with Offset Distances

When there are two remote DAX locations in one crossing approach, there are two options for cascading the two remotes. Option A uses prime predictors at the remotes and Option B uses DAX predictors (80016 Module) at the remotes.

10.10.2.1 Option A – Prime Predictors at the Remotes

In Figure 10-29, the two remote GCPs have their prime predictors ANDed together (cascaded) by using the ENABLE at GCP2. The application is as follows:

1. GCP3: Program T1 prime prediction offset for the distance to the crossing (2012 feet)
2. GCP3: Wire GCP output to line circuit to GCP2 ENA input
3. GCP2: Program ENA/UAX2 input for 0 (zero) seconds
4. GCP2: Program T1 and T2 prime prediction offsets for the distance to the crossing (both are set to 1455 feet)
5. GCP2: Wire GCP output to line circuit to GCP1 ENA input



6. GCP1: Program ENA/UAX2 input for 0 (zero) seconds (ENABLE)

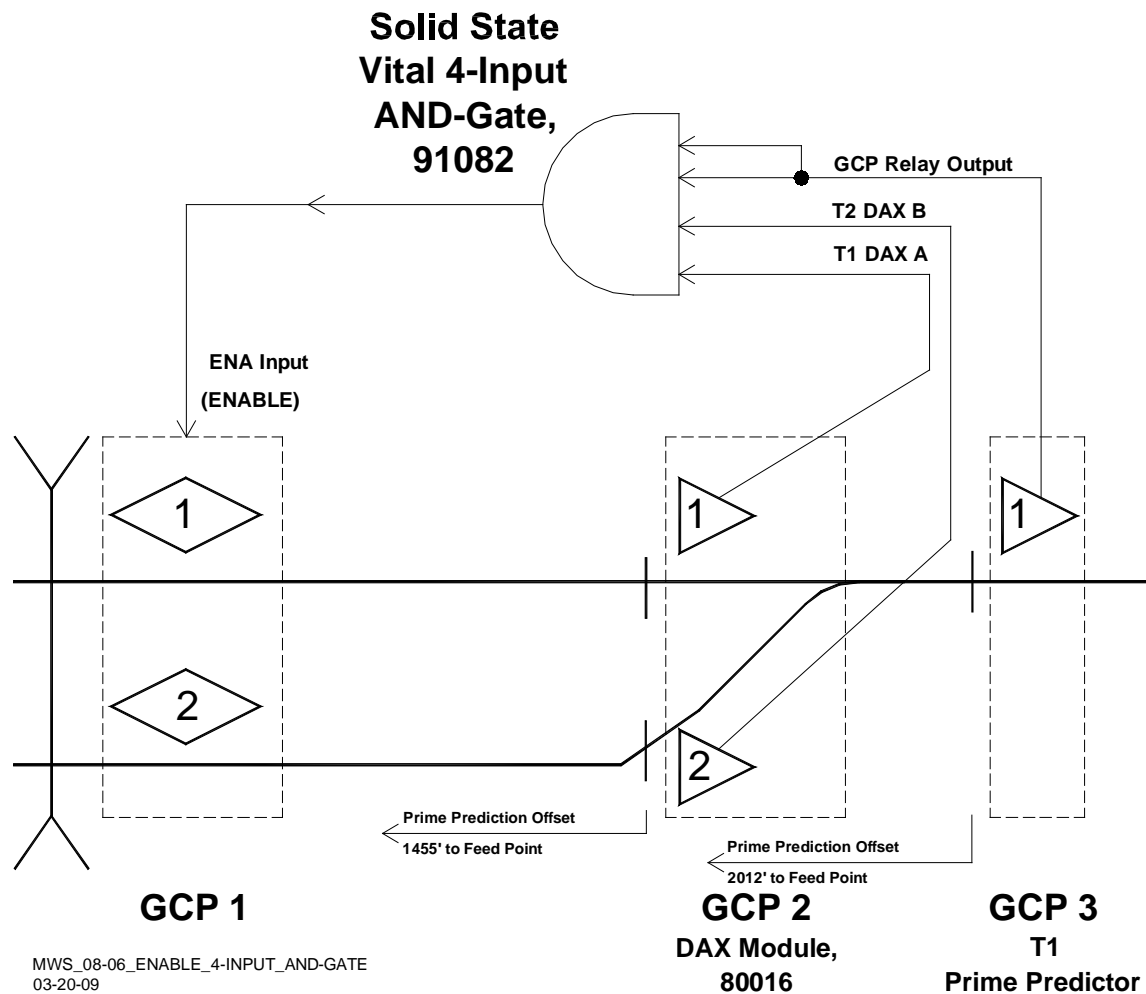
Figure 10-29:
Cascading Remote Predictors Using Offset Distances

10.10.2.2 Option B – DAX Predictors ANDed Using a Vital 4-Input AND-Gate

In Figure 10-30, the two remote GCPs have their DAX predictors ANDed together (cascaded) by using the Solid State Vital 4-Input AND-Gate, 91082. The application is as follows:

1. GCP3: Program T1 prime prediction offset for the distance to the crossing (2012 feet)
2. GCP3: Wire GCP output to line circuit. The line circuit drives 2 inputs of the Vital 4-Input AND-Gate located at GCP2.

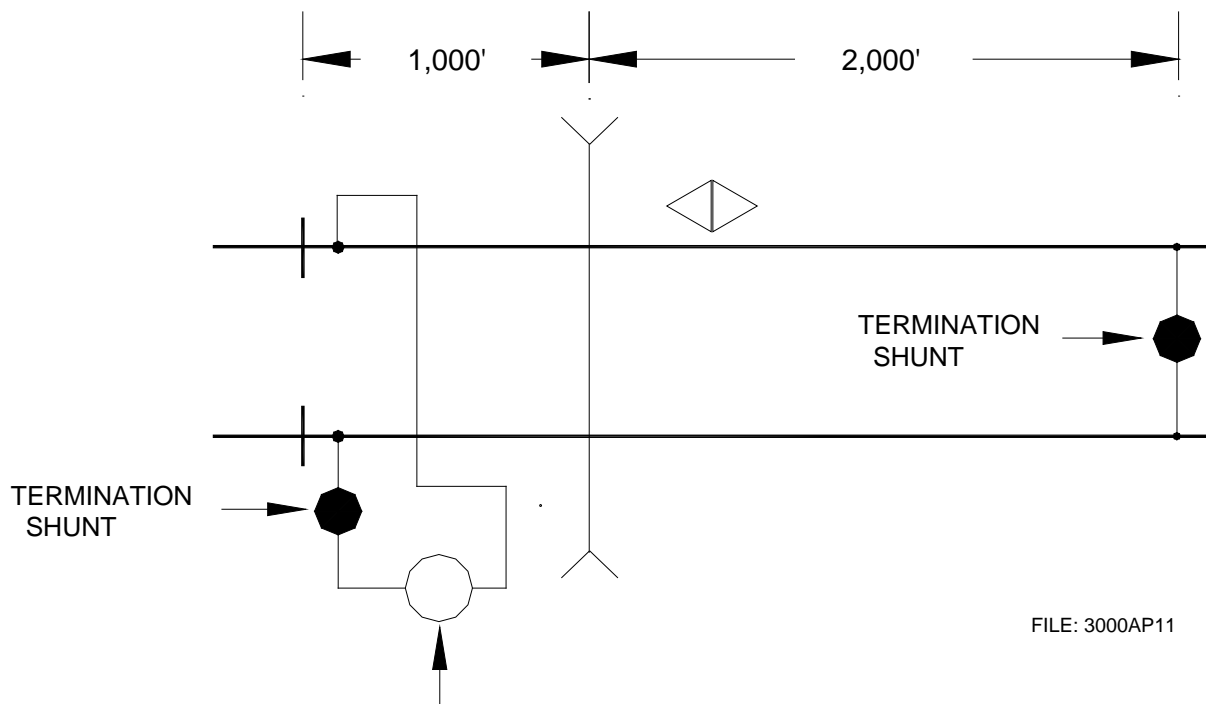
3. GCP2: Program DAX A to T1 and DAX B to T2.
4. GCP2: Program T1DAX A predictor offset distance for the distance to the crossing (1455 feet). Wire DAX A output to an input of the Vital 4-Input AND-Gate.
5. GCP2: Program T1DAX A predictor offset distance for the distance to the crossing (1455 feet). Wire DAX A output to an input of the Vital 4-Input AND-Gate.
6. GCP2: Wire output of Vital 4-Input AND-Gate to line circuit going to GCP1. Line circuit terminates at GCP1 ENA/UAX2 input.
7. GCP1: Program ENA input for 0 (zero) seconds (ENABLE).



**Figure 10-30:
Cascading Remote Predictors using Vital 4-Input AND-Gate**

SECTION 11 – UNEQUAL BIDIRECTIONAL APPROACH DISTANCES

When the 3000 GCP is operating in a bidirectional application, the two approaches must not differ in length by more than 10 percent. In applications where approach distances differ by more than 10 percent, insulated joints that are not bypassed must be located at the termination point of the shorter approach. Simulated track must then be added in series with the termination shunt on the shorter approach. Three options are available and include (1) Simulated Track Inductor, 8V617, with a multifrequency narrow-band shunt (see paragraph 12.11), (2) Adjustable Inductor, 8A398-6, with single frequency shunts (paragraph 12.12), or (3) Bidirectional Simulation Coupler, 62664-Mf (see paragraph 12.2). Each method is chosen such that the two approach distances are effectively equal, or slightly greater (less than 10 percent) than the longer approach. When using the bidirectional simulation coupler, track leads should be number 6 AWG twisted and a maximum length of 25 feet.



8A398-6 ADJUSTABLE
INDUCTOR (IN WEATHERPROOF ENCLOSURE)
SET TO BALANCE APPROACH
OR
SIMULATED TRACK INDUCTOR
8V617-1000 LOCATED IN
MULTIFREQUENCY TERMINATION SHUNT
OR
BIDIRECTIONAL SIMULATION
COUPLER, 62664-MF
(IN WEATHERPROOF ENCLOSURE)

**Figure 11-1:
Simulated Track Added to Balance Unequal Bidirectional Approach Distance**

This page intentionally left blank.

SECTION 12 – AUXILIARY EQUIPMENT

12.1 GENERAL

The equipment described in the following paragraphs may be used with the 3000 GCP. Where applicable, installation and adjustment information is provided. The following equipment is covered in this section:

**Table 12-1:
Auxiliary Equipment Index**

SECTION	EQUIPMENT COVERED	PAGE
12.2.1	Automatic Transfer Timer Unit, 80024	12-2
12.2.2	Data Recorder Module, 80115	12-10
12.2.3	Data Recorder Interface Assembly, 80025	12-10
12.2.4	Relay Adapter Module, 80170	12-12
12.2.5	Extender Module, 80021	12-13
12.2.6	3000 GCP Slaving Unit, 80065	12-13
12.2.7	MS/GCP to Network Interface Plug Assembly, 80063	12-14
12.2.8	Simulated Track Assembly, 80071	12-15
12.3	GENERIC GRADE CROSSING PREDICTOR AUXILIARY EQUIPMENT	12-18
12.3.1	Bidirectional Simulation Coupler, 62664-MF	12-18
12.3.2	MS/GCP Termination Shunt Burial Kit, A62776	12-22
12.3.3	Six-Wire Simulated Track Burial Assembly, 80074	12-23
12.3.4	DC Shunting Enhancer Panel, 80049	12-23
12.3.5	Vital AND-Gate, 2-Input 90975	12-26
12.3.6	Vital AND-Gate, 4-Input, 91082	12-29
12.4	TRACK CIRCUIT ISOLATION DEVICES	12-32
12.4.1.	Steady Energy DC Track Circuits	12-32
12.4.1.1	Battery Chokes, 62648 & 8A065	12-33
12.4.2	Safetran GEO Electronic DC Coded System	12-34
12.4.3	Electro Code Electronic Coded System	12-34
12.4.4	Relay Coded DC Track	12-34
12.4.4.1	DC Code Isolation Units, 6A342-1 & 6A342-3	12-34
12.4.5	Single Polarity Systems (Fixed Polarity)	12-36
12.4.6	GRS Trakode (Dual Polarity) Systems	12-36
12.4.7	Dual Polarity (Polar) Coded Track Systems Other Than GRS Trakode	12-36
12.4.8	AC Cab Signal	12-36
12.4.8.1	AC Code Isolation Unit, 8A466	12-37
12.4.8.2	AC Code Isolation Unit, 8A471-100 & 8A471-180	12-37
12.4.9	Style C Track Circuits	12-38
12.5	COUPLERS AND SHUNTS	12-40
12.5.1	Tunable Insulated Joint Bypass Coupler, 62785-F	12-40
12.5.2	Narrow-Band Shunt, 62775-f	12-42
12.5.3	Narrow-Band Shunt, 62780-f	12-43

**Table 12-1:
Auxiliary Equipment Index**

SECTION	EQUIPMENT COVERED	PAGE
12.5.4	Adjustable Inductor Assembly, 8A398-6 (Used With Single- Frequency Shunts Only)	12-44
12.5.5	Multifrequency Narrow-Band Shunt, 62775-XXXX	12-46
12.5.6	Multifrequency Narrow-Band Shunt, 62780-XXXX	12-48
12.5.7	Simulated Track Inductor, 8V617 (Used With Multifrequency Shunts Only)	12-49
12.5.8	Wideband Shunt, 8A076A	12-52
12.6	SURGE SUPPRESSION PANELS, 80026-XX	12-52
12.6.1	Surge Panels 80026-01, -02, -22, --1, -32, -33, -34, -35, -36, -37, -38, -39, -41, -41A, & -50	12-52
12.7	AUXILIARY EQUIPMENT PANELS	12-61
12.7.1	Rectifier Panel Assembly, 80033	12-61
12.7.2	Cable Termination Panel Assembly, 91042	12-61
12.7.3	Data Recorder Interface & Vital AND-Gate Driver Panel Assembly, 91043	12-62
12.7.4	Vital AND-Gate Driver Panel Assembly, 91044	12-62

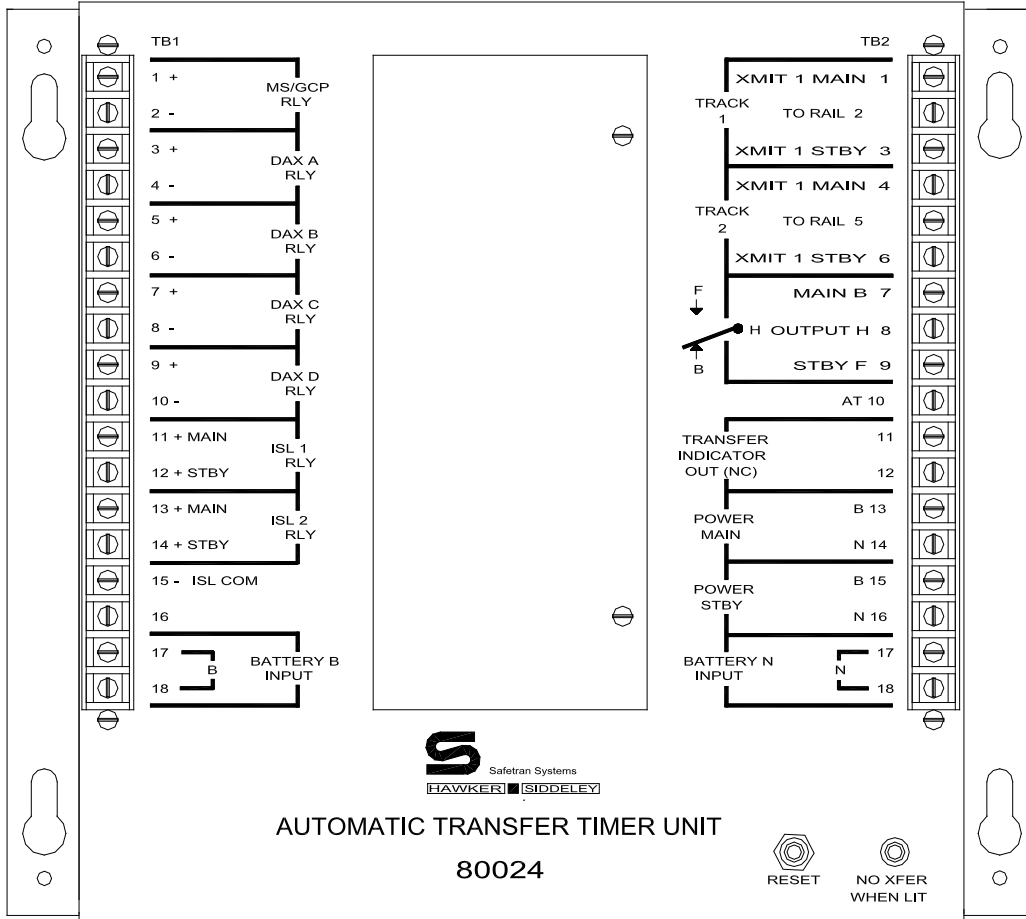
12.2 SPECIFIC MODEL 3000 GRADE CROSSING PREDICTOR AUXILIARY EQUIPMENT

The equipment shown in this section is only used with Model 3000 GCPs.

12.2.1 Automatic Transfer Timer Unit, 80024

The automatic transfer timer unit () is connected to two Model 3000 GCPs and, in the event of a failure of the primary (main) unit, operation is automatically transferred to the stand-by (backup) unit within a pre-established time period. The transfer interval is field programmable from 3 to 31 minutes in 1-minute increments and is normally set for 3 minutes. The automatic transfer timer will continue to switch between the two GCPs in an effort to select an operational unit.

The field programmable transfer interval is selected via DIP switch S1 located on the internal 80023 module (Figure 12-2). The five segments of S1 correspond to the binary values printed on the 80023 circuit board adjacent to S1. To select a value, press the corresponding switch lever(s) to the down or ON position as indicated in Figure 12-2. See Table 12-2 for transfer interval switch settings.



FILE: 80024A

Figure 12-1:
Automatic Transfer Timer Unit, 80024

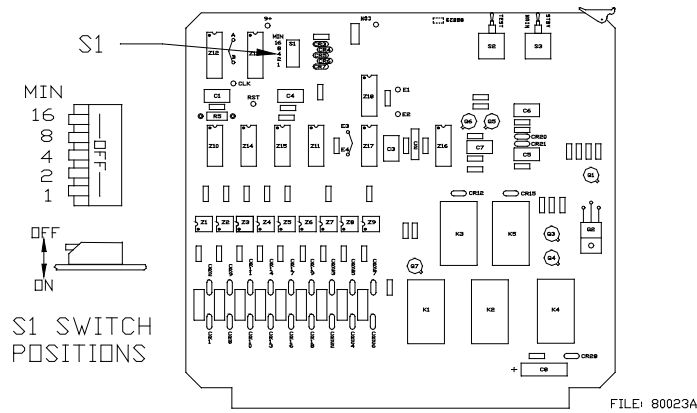


Figure 12-2:
Location of Transfer Interval Select Switch (S1) On 80023 Module

**Table 12-2:
Transfer Time Interval Selection**

TIME (MINUTES)	TRANSFER TIMER SWITCH POSITIONS				
	16	8	4	2	1
3	Up	Up	Up	Down	Down
4	Up	Up	Down	Up	Up
5	Up	Up	Down	Up	Down
6	Up	Up	Down	Down	Up
7	Up	Up	Down	Down	Down
8	Up	Down	Up	Up	Up
9	Up	Down	Up	Up	Down
10	Up	Down	Up	Down	Up
11	Up	Down	Up	Down	Down
12	Up	Down	Down	Up	Up
13	Up	Down	Down	Up	Down
14	Up	Down	Down	Down	Up
15	Up	Down	Down	Down	Down
16	Down	Up	Up	Up	Up
17	Down	Up	Up	Up	Down
18	Down	Up	Up	Down	Up
19	Down	Up	Up	Down	Down
20	Down	Up	Down	Up	Up
21	Down	Up	Down	Up	Down
22	Down	Up	Down	Down	Up
23	Down	Up	Down	Down	Down
24	Down	Down	Up	Up	Up
25	Down	Down	Up	Up	Down
26	Down	Down	Up	Down	Up
27	Down	Down	Up	Down	Down
28	Down	Down	Down	Up	Up
29	Down	Down	Down	Up	Down
30	Down	Down	Down	Down	Up
31	Down	Down	Down	Down	Down

The automatic transfer timer unit is also equipped with an LED indicator and a number of switches which are used primarily for calibration and test purposes. Each of the devices is described in Table 12-3.

**Table 12-3:
Automatic Transfer Timer Unit Controls and Indicators**

DEVICE & LOCATION	NOMENCLATURE	FUNCTION
Switch (800234 Module)	STBY-AUTO-MAIN	Selects standby/main operating system or automatic transfer mode.
Switch (80023 Module)	TEST	When pressed, causes transfer from main to standby GCP.
Switch (80024 Case)	RESET	Following transfer from main to standby GCP, press to return to main GCP.
LED (80024 Case)	NO XFER WHEN LIT	Transfer indicator: normally lighted; extinguished when main to standby GCP transfer occurs.

The automatic transfer timer unit is housed in an aluminum case designed for shelf- or backboard-mounting. The mounting dimensions for the unit are provided in Figure 12-3. Table 12-4 lists the front panel terminals and their GCP connections. Figure 12-4 illustrates a typical single track, bidirectional application using the automatic transfer timer unit with two 3000 GCPs.

Specifications for the automatic transfer timer unit are as follows:

**Table 12-4:
Automatic Transfer Timer Unit Specifications**

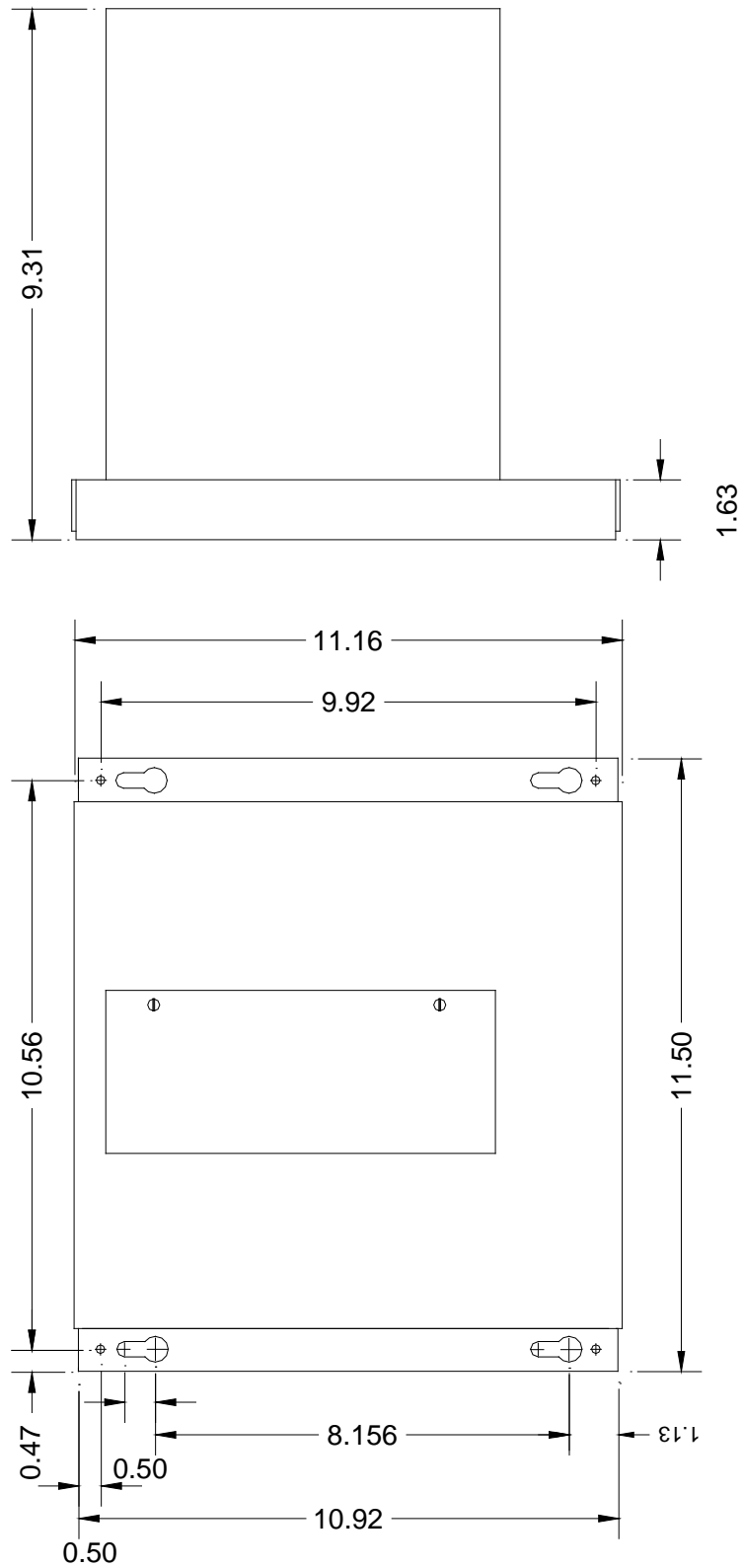
PARAMETER	VALUES
Environmental	-40° F to +160° F (-40° C to +71° C)
Dimensions	
Height	9.31 inches (23.6 centimeters)
Width	11.50 inches (29.2 centimeters)
Depth	11.16 inches (28.3 centimeters)
Weight	4 pounds, 12 ounces (2.15 kilograms) (approximate)

**Table 12-5:
Automatic Transfer Timer Unit Terminal Connections**

TERMINAL	NOMENCLATURE	CONNECTION
TB1-1	+ MS/GCP RLY	Positive terminal of GCP relay, or + GCP RLY terminal (TB1-9) on main GCP
TB1-2	- MS/GCP RLY	Negative terminal of GCP relay, or – GCP RLY terminal (TB1-10) on main GCP
TB1-3	+ DAX A RLY	If no DAX A, connect to 80024 BATTERY B INPUT (TB1-17). If DAX A is used, connect to + DAX A RLY terminal (TB1-13) on main GCP.
TB1-4	- DAX A RLY	If no DAX A, connect to 80024 BATTERY N INPUT (TB2-17). If DAX A is used, connect to – DAX A RLY terminal (TB1-14) on main GCP.
TB1-5	+ DAX B RLY	If no DAX B, connect to 80024 BATTERY B INPUT (TB1-17). If DAX B is used, connect to + DAX B RLY terminal (TB1-15) on main GCP.
TB1-6	- DAX B RLY	If no DAX B, connect to 80024 BATTERY N INPUT (TB2-17). If DAX B is used, connect to - DAX B RLY terminal (TB1-16) on main GCP.
TB1-7	+ DAX C RLY	If no DAX C, connect to 80024 BATTERY B INPUT (TB1-17). If DAX C is used, connect to + DAX C RLY terminal (TB2-13) on main GCP.
TB1-8	- DAX C RLY	If no DAX C, connect to 80024 BATTERY N INPUT (TB2-17). If DAX C is used, connect to - DAX C RLY terminal (TB2-14) on main GCP.
TB1-9	+ DAX D RLY	If no DAX D, connect to 80024 BATTERY B INPUT (TB1-17). If DAX D is used, connect to + DAX D RLY terminal (TB2-15) on main GCP.
TB1-10	- DAX D RLY	If no DAX D, connect to 80024 BATTERY N INPUT (TB2-17). If DAX D is used, connect to - DAX D RLY terminal (TB2-16) on main GCP.
TB1-11	+ ISL 1 RLY MAIN	Not used
TB1-12	+ ISL 1 RLY STBY	Not used
TB1-13	+ ISL 2 RLY MAIN	Not used
TB1-14	+ ISL 2 RLY STBY	Not used
TB1-15	ISL COM	Not used
TB1-16		Not used
TB1-17	BATTERY B INPUT	Positive GCP battery supply as needed for 80024 connections
TB1-18	BATTERY B INPUT	Connect to positive GCP battery terminal (B12).
TB2-1	TRACK 1 XMIT 1 MAIN	TRACK 1, XMT 1 terminal (TB1-1) on main GCP
TB2-2	TRACK 1 TO RAIL	Connect as XMT 1 wire to rail on track 1.
TB2-3	TRACK 1 XMIT 1 STBY	TRACK 1, XMT 1 terminal (TB1-1) on standby GCP
TB2-4	TRACK 2 XMIT 1 MAIN	TRACK 2, XMT 1 terminal (TB2-1) on main GCP
TB2-5	TRACK 2 TO RAIL	Connect as XMT 1 wire to rail on track 2.

**Table 12-5:
Automatic Transfer Timer Unit Terminal Connections**

TERMINAL	NOMENCLATURE	CONNECTION
TB2-6	TRACK 2 XMIT 1 STBY	TRACK 2, XMT 1 terminal (TB2-1) on standby GC
TB2-7	MAIN B	Spare relay contact
TB2-8	OUTPUT H	Spare relay contact
TB2-9	STBY F	Spare relay contact
TB2-10	AT	AT (automatic transfer) terminal (TB2-5) on main GCP
TB2-11	TRANSFER INDICATOR OUT (NC)	Output for external transfer indication such as POE light on enclosure
TB2-12	TRANSFER INDICATOR OUT (NC)	Output for external transfer indication such as POE light on enclosure
TB2-13	POWER MAIN B	Positive battery supply. Connect to B battery terminal (TB1-6) on main GCP.
TB2-14	POWER MAIN N	Negative battery supply. Connect to N battery terminal (TB1-8) on main GCP.
TB2-15	POWER STBY B	Positive battery supply. Connect to B battery terminal (TB1-6) on standby GCP
TB2-16	POWER STBY N	Negative battery supply. Connect to N battery terminal (TB1-8) on standby GCP.
TB2-17	BATTERY N INPUT	Negative GCP battery supply as Needed for 80024 connections
TB2-18	BATTERY N INPUT	Connect to negative GCP battery terminal (N12).



FILE: 80024D

**Figure 12-3:
Automatic Transfer Timer Unit Mounting Dimensions**

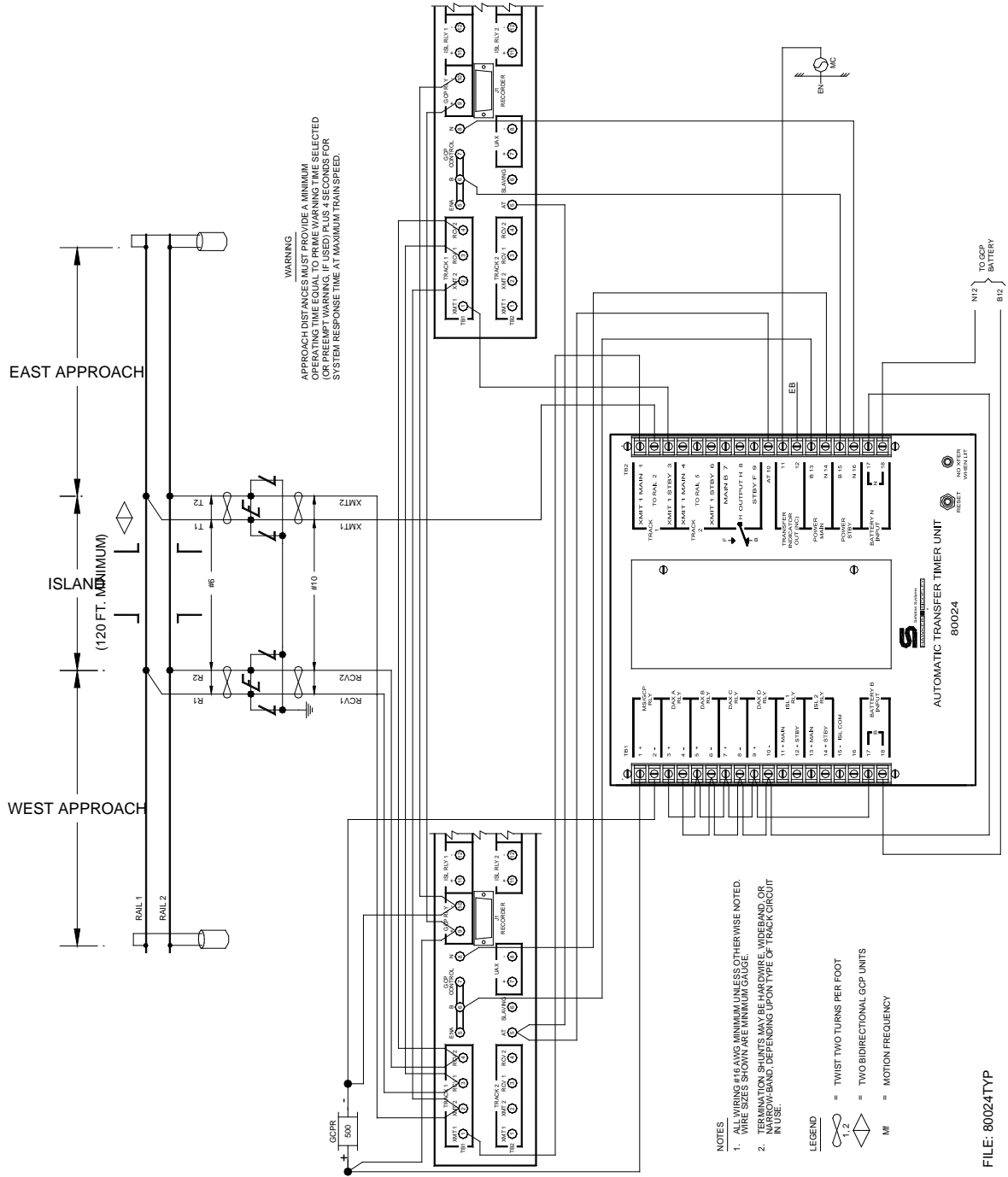


Figure 12-4:
Typical Single Track, Bidirectional Application with Automatic Transfer Timer Unit And Two 3000 GCPs

12.2.2 Data Recorder Module, 80115

Data recording capability is provided by the Data Recorder Module (80115) which plugs into a card slot in the GCP case. When used alone, the module maintains a date and time-stamped record of train warning times, detected train speed (speed of train when prediction occurred), average train speed (speed of train averaged over entire time train is sensed), and island speed (speed of train when entering island). Additionally, any errors normally detected by the GCP, either internally or in the track circuit, are also recorded (refer to Section 9, Data Recorder, in the Model 3000 GCP Instruction And Installation Manual for complete details).

NOTE

NOTE

The recorded speed information is intended solely as a maintenance tool. The speed values are relative and may be affected by track parameters that include:

- Insulated joint proximity
- Insulated joint couplers
- Overlapping termination shunts
- Lumped ballast loads

The speed values are only intended to assist maintenance personnel in:

- Identifying slow versus fast train movements
- Distinguishing between accelerating, decelerating, and relatively constant speed train movements

Recorded time intervals reflect the time between train detection and island occupancy and do not represent total warning time.

- Warning time may be shorter because of relay or controller reaction times

The primary function of the recording is to document warning time.

- Speed values are secondary and may not be consistent with recordings made by devices specifically designed to record train speed.

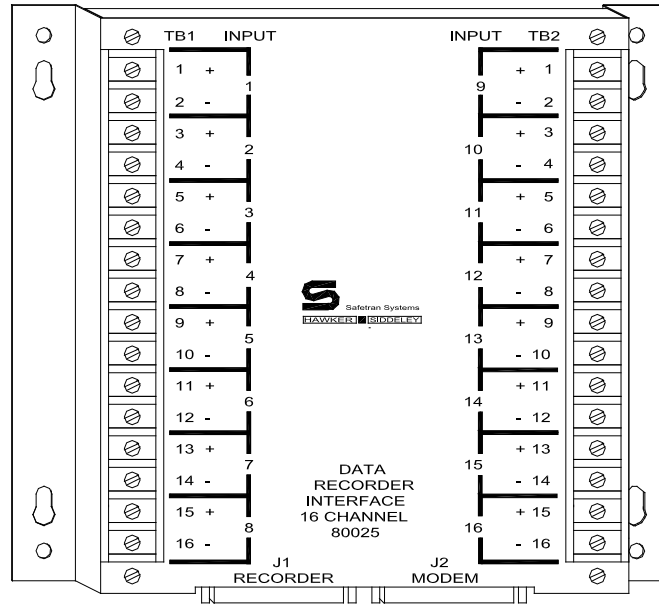
For expanded recording capabilities, a Data Recorder Interface Assembly (80025) can be attached to the GCP to provide 16 optically-isolated external inputs (channels) to the data recorder module (see paragraph 12.2.3).

12.2.3 Data Recorder Interface Assembly, 80025

Data Recorder Interface Assembly, 80025 (Figure 12-5), enables the Data Recorder Module, 80115, to monitor and record changes of input state on 16 channels external to the 3000 GCP. The data recorder interface assembly interfaces with the data recorder via a 5-foot 25-line cable (supplied with the unit) connected between J1 (RECORDER) on the 3000 GCP front panel and J1 (RECORDER) on the data recorder interface assembly. Pin assignments for connector J1 on the data recorder interface assembly are provided in Table 12-3.

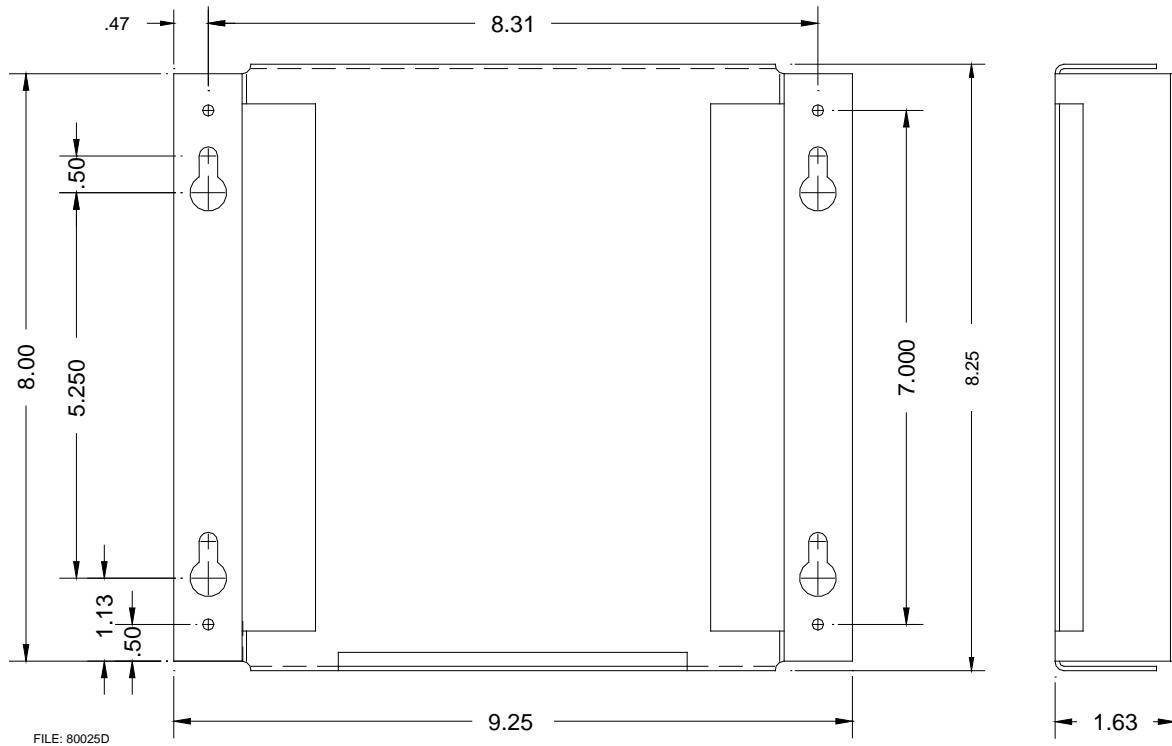
All 16 inputs on the data recorder interface assembly are electrically isolated from each other and from ground by optical isolators, allowing direct connection to vital circuits. Input changes must typically consist of voltage level changes similar to those produced by relay contact closures (i.e., low-to-high and high-to-low). Each channel input from a monitored signal circuit consists of two wires attached to screw terminals on the data recorder interface assembly. See Table 12-7 for assembly mounting dimensions.

For installations in which a modem is used, the length of the cable connecting the modem to the data recorder interface assembly should be limited to 50 feet.



FILE: 80025

**Figure 12-5:
Data Recorder Interface Assembly, 80025**



**Figure 12-6:
Data Recorder Interface Assembly Mounting Dimensions**

**Table 12-6:
Data Recorder Interface Assembly Connector J1 Pin Assignments**

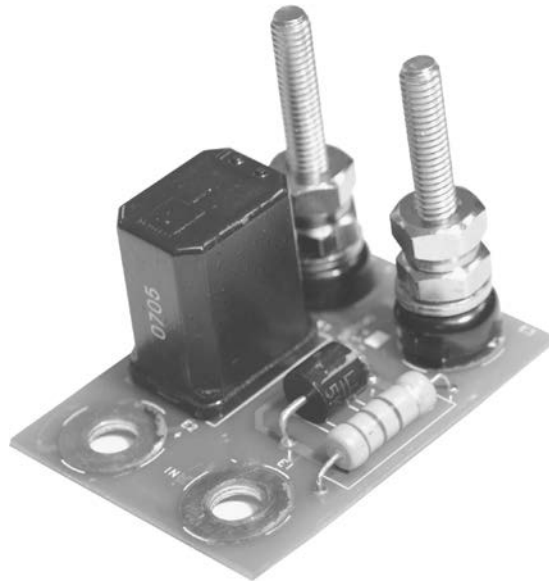
PIN	SIGNAL	PIN	SIGNAL
1	Ground	14	Channel 16
2	Transmit Data (TxD)	15	Channel 15
3	Receive Data (RxD)	16	Channel 14
4	Request To Send (RTS)	17	Channel 13
5	Clear To Send (CTS)	18	Channel 12
6	Data Set Ready (DSR)	19	Channel 11
7	Ground	20	Data Terminal Ready (DTR)
8	Data Carrier Detect (DCD)	21	Channel 10
9	Channel 9	22	Channel 1
10	Channel 2	23	Channel 3
11	Channel 4	24	Channel 5
12	Channel 6	25	Channel 7
13	Channel 8		

**Table 12-7:
Data Recorder Interface Assembly Specifications**

PARAMETER	VALUES
Channel Inputs	
Number of Inputs	16
Input Resistance	5k Ohms
Input Voltage	8 to 36 VDC
Terminal Screw Size	No. 6
Dimensions	
Height	1.88 inches (4.8 centimeters)
Width	9.25 inches (23.5 centimeters)
Depth	8.25 inches deep (21 centimeters)
Weight	1 pounds (0.45 kilograms) (approximate)

12.2.4 Relay Adapter Module, 80170

Relay Adapter Module (Safetran P/N 8000-80170-001) (see Figure 12-7) must be installed in all existing and future applications where a 3000 MS will be used to directly drive (no relay isolation) any UAX, ISL RLY, MS/GCP CONTROL and/or ENA input on one 3000 GCP and/or 2000 MS unit by the GCP RLY (3000 GCP) and/or MS RLY (2000 MS) output of another unit. The Relay Adapter Module A80170 is installed externally to the 3000 GCP unit and can be wired into the system as shown in Figure 14-14.



**Figure 12-7:
80170 Relay Adapter Module**

NOTE

The Relay Adapter Module is not required where vital relays are used as an interface between the UAX, ISL RLY, MS/GCP CONTROL and/or ENA inputs of one unit and the GCP RLY (3000GCP) or MS RLY (2000MS) output of another unit.

12.2.5 Extender Module, 80021

The Extender module can be used with all 3000 GCP plug-in modules and is primarily a troubleshooting device that permits access to a module installed in the 3000 GCP case for test purposes.

The Extender module plugs into the case connector on the motherboard and the module under test is then plugged into the Extender module.

- The 80021 Extender Module is equipped with dual 43-pin connectors.
- Test terminals are provided for each connector pin.
- The module cannot be used with any other equipment

The Extender module is 8 inches (20.3 centimeters) high by 8.9 inches (22.6 centimeters) wide.

12.2.6 3000 GCP Slaving Unit, 80065

When two 3000 GCP's are frequency slaved in a master/slave configuration, and the two GCP's are powered from separate batteries, a Model 3000 GCP Slaving Unit, 80065, must be used to isolate the two batteries.

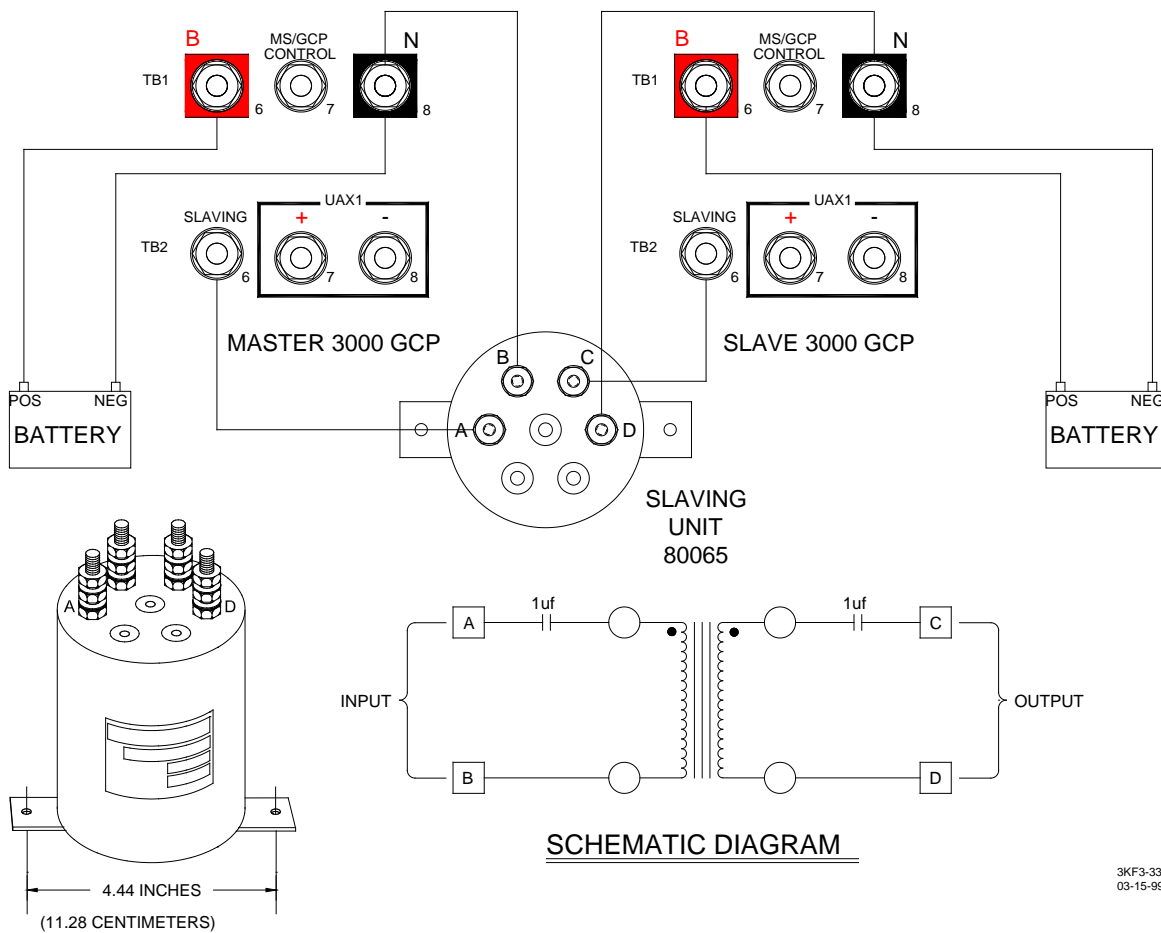
- Without the isolation provided by the Slaving unit, a grounded battery would be reflected in both sets of GCP operating batteries.
- The Slaving unit prevents this interaction from occurring.
- When the two 3000 GCP's are operated from the same battery, the Slaving unit is not required.

The Slaving unit consists of a 3-inch diameter by 5-inch long ABS plastic enclosure with mounting brackets at the base.

- Four AREMA terminals extend from the top of the assembly and accommodate connections to separate windings of an isolation transformer housed within the hermetically sealed enclosure.
- The terminals are connected between the battery **N (TB1-8)** and **SLAVING (TB2-6)** terminals on the master 3000 GCP and the same pair of terminals on the slave unit as shown in Figure 12-8.

**Table 12-8:
3000 GCP Slaving Uni, 80065 Specifications**

PARAMETER	VALUES
Dimensions	
Diameter	3.5 inches (8.89 centimeters)
Height	7.625 inches (19.37 centimeters) (to top of AREMA terminals)
Weight	2 pounds (0.91 kilograms) (approximate)



**Figure 12-8:
3000 GCP Slaving Unit, 80065**

12.2.7 MS/GCP to Network Interface Plug Assembly, 80063

The 80063 MS/GCP to Network Interface Plug Assembly (Figure 12-9) provides connection points for the two-wire Echelon LonTalk™ network.

- The 80063 plugs into the 25-pin J1 RECORDER connector of the GCP.
- Echelon network connection points are the ECH terminals on the front of the assembly.

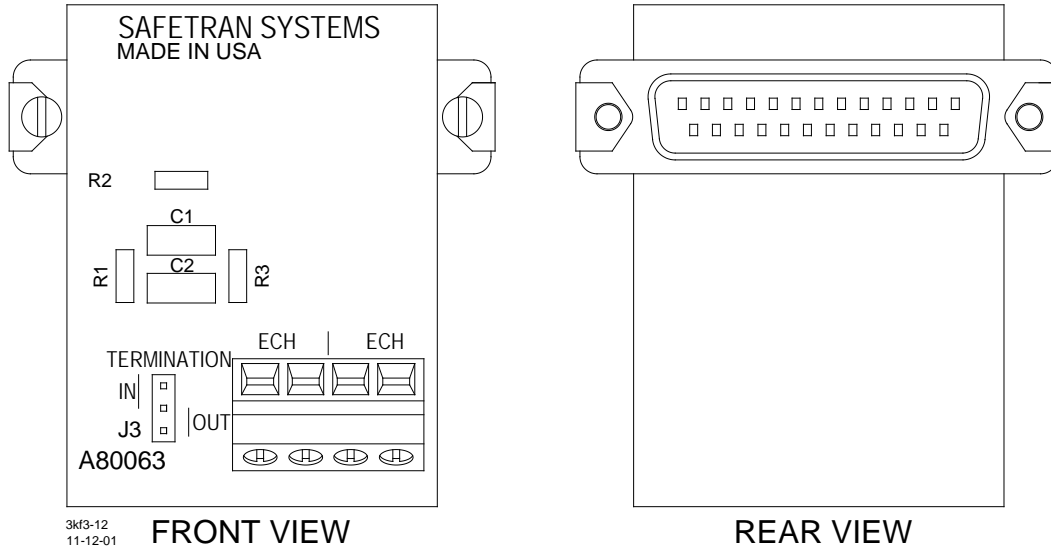


Figure 12-9:
MS/GCP to Network Interface Plug Assembly, 80063

Table 12-9:
MS/GCP to Network Interface Plug Assembly Specifications

PARAMETER	VALUES
Environmental	40°F to +158°F (-40°C to +70°C)
Dimensions	
Height	2.2 inches (5.6 centimeters)
Width	2.1 inches (5.33 centimeters)
Depth	1.12 inches (2.85 centimeters)
Weight	0.05 pounds (0.00225 kilograms) (approximate)

12.2.8 Simulated Track Assembly, 80071

Track 1 or track 2 can be temporarily removed from service by installing the 80071 Simulated Track Assembly between the applicable track 1 or track 2 transmitter output terminals (XMT 1 or XMT 2) on the front panel of the 3000 GCP case.

The Simulated Track Assembly (Figure 12-10) consists of a plastic housing containing a special simulated track inductor.

- A pair of 10-foot, number 10 AWG, stranded leads with yellow insulation and AREMA lugs extend from one end of the housing.
- The bright yellow leads permit an out-of-service track condition to be easily identified.

12.2.8.1 Instructions For Taking a Track Out of Service

Perform the following steps to temporarily take track 1 or track 2 out of service.

WARNING

WARNING

THE RAILROAD PROCEDURES GOVERNING HOW TO TAKE A TRACK CIRCUIT OUT OF SERVICE SHALL BE FOLLOWED. THE INSTRUCTIONS IN THIS SECTION MAY BE FOLLOWED ONLY IF ALLOWED BY THE RAILROAD.

ALWAYS VERIFY THAT THE PROPER 3000 GCP TRACK (T1 OR T2) IS BEING TAKEN OUT OF SERVICE.

INSTALLATION OF THE SIMULATED TRACK ASSEMBLY MAY AFFECT WARNING TIMES AT OTHER NEARBY OPERATING CROSSINGS. THIS CAN OCCUR WHEN APPROACHES OF THE NEARBY CROSSINGS OVERLAP THE ISLAND CIRCUIT OF THE CROSSING WHICH IS BEING TAKEN OUT OF SERVICE, OR IF THE NEARBY CROSSING(S) RECEIVE(S) A DAX SIGNAL FROM THE 3000 GCP TRACK CIRCUIT WHICH IS BEING TAKEN OUT OF SERVICE.

NOTE

NOTES

When connecting the two simulated track assembly leads, place one lug on the appropriate transmitter output terminal and tighten the AREMA nut securely.

While installing the second lead, hold the lug firmly on the other terminal while tightening the nut to ensure a solid electrical connection.

If a solid electrical connection is not achieved when connecting the second lead of the simulated track assembly, apparent motion may be sensed or an error condition may be produced, de-energizing one or more relay drives. If this occurs, disconnect one lead of the simulated track assembly, wait for all relay drives to recover, and then repeat step 2.

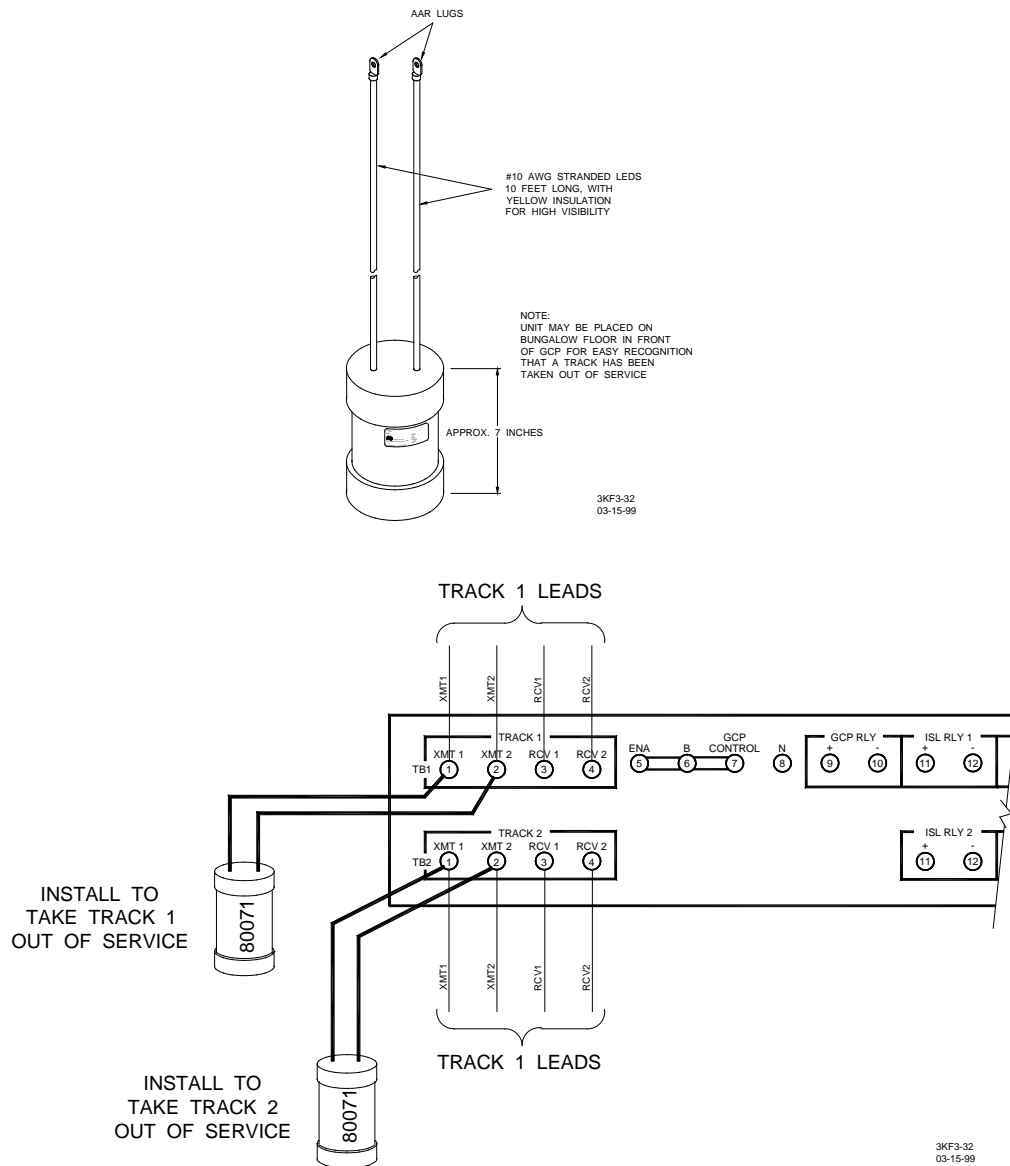


Figure 12-10:
Simulated Track Inductor Assembly, 80071

1. Verify that no train moves are occurring on the track and that the proper relay drive voltages are present before continuing.
2. Install the two leads (Figure 12-10) of the simulated track assembly (80071) on the associated transmitter output terminals for the track that is being taken out of service (TB1-1 and TB1-2 or TB2-1 and TB2-2).

The applicable track circuit is now out of service; however, the island circuit remains operational.

12.2.9 Returning a Track to Service

1. To return track 1 or track 2 to service, disconnect the simulated track assembly (step 2).
2. With no trains operating in the approaches, verify that the track EZ value has returned to its nominal level.

- In addition, ensure that all other railroad instructions and procedures for returning a track to service are followed.

12.3 GENERIC GRADE CROSSING PREDICTOR AUXILIARY EQUIPMENT

The following equipment is used by various Safetran Grade Crossing Predictors.

12.3.1 Bidirectional Simulation Coupler, 62664-MF

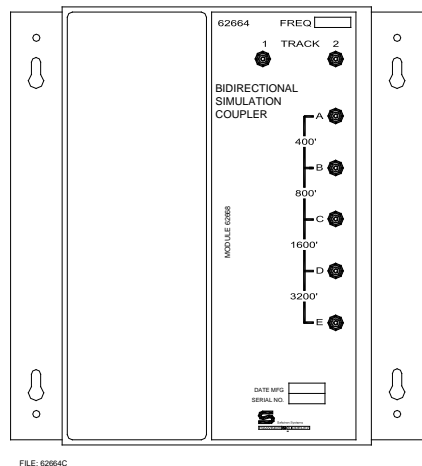
Low ballast resistance effectively reduces approach distances to a greater degree in unidirectional 3000 GCP installations than in bidirectional installations. Although the 3000 GCP can be operated unidirectionally while DAXing, a technique referred to as bidirectional simulation can be applied to a unidirectional installation to obtain the operating benefits of a bidirectional application. A unidirectional 3000 GCP can provide a DAX start for an adjacent street, as well as other unidirectional applications, while operating as a simulated bidirectional GCP (GCP must be programmed for bidirectional operation).



WARNING

THE 3000 GCP IS THE ONLY MS/GCP THAT CAN OPERATE UNIDIRECTIONALLY IN A SIMULATED BIDIREC-TIONAL MODE WHILE DAXING.

In a simulated bidirectional configuration, an NBS is connected in series with an adjustable inductor. The combination is then connected in parallel across the track connections so that the circuit is electrically equal to that of the actual track approach circuit. To the 3000 GCP, both approach circuits appear equal in length, even though one of the circuits consists of the shunt and inductor, which are located in the instrument housing/bungalow.



FILE: 62664C

**Figure 12-11:
Bidirectional Simulation Coupler, 62664-Mf**

Bidirectional Simulation Coupler, 62664-Mf, (see Figure 12-11) is a convenient, compact, shelf- or backboard-mounted unit containing both an NBS of the same frequency as the GCP and an adjustable inductor (simulated track).



NOTE

The Bidirectional Simulation Coupler, 62664-Mf, cannot be used as a termination shunt.

The bidirectional simulation coupler is housed in a brushed aluminum case which contains a single plug-in type printed circuit board and four toroid-wound inductors, each of which simulates a specific length of track. The inductors are wired in series with taps provided which enable strapping of front panel terminals

for selecting approach distances to closely match the actual track approach ranging from 400 to 6,000 feet as indicated in Table 12-10.

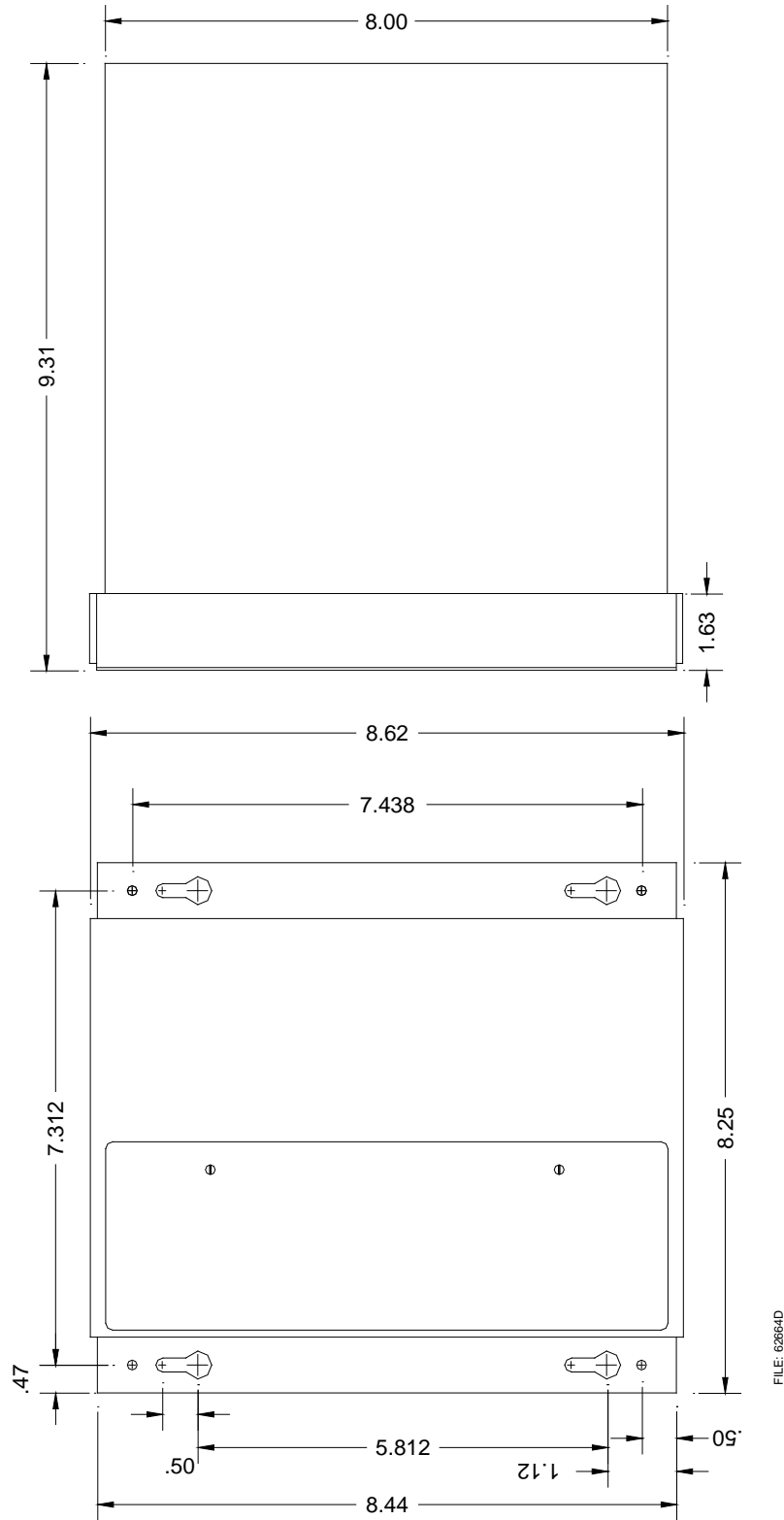
**Table 12-10:
Approach Distance Selection Strapping**

DISTANCE (FT)	STRAP TERMINALS	DISTANCE (FT)	STRAP TERMINALS
400	B-C, C-D, D-E	3,600	B-C, C-D
800	A-B, C-D, D-E	4,000	A-B, C-D
1,200	C-D, D-E	4,400	C-D
1,600	A-B, B-C, D-E	4,800	A-B, B-C
2,000	B-C, D-E	5,200	B-C
2,400	A-B, D-E	5,600	A-B
2,800	D-E	6,000	NO STRAPS
3,200	A-B, B-C, C-D		

Mounting dimensions for the Bidirectional Simulation Coupler Assembly are provided in Figure 12-12 while a typical application is illustrated in Figure 12-13.

**Table 12-11:
Bidirectional Simulation Coupler Specifications**

PARAMETER	VALUES
Environmental	-40° F to +160° F (-40° C to +71° C)
Dimensions	
Height	8.75 inches (22.2 centimeters)
Width	8.50 inches (21.6 centimeters)
Depth	9.25 inches deep (23.5 centimeters)
Weight	5 pounds (2.27 kilograms) (approximate)
Adjustment Range	400 to 6,000 feet (must be within ±10% of actual approach distance)
Loading Effect	Loading effect of internal narrow-band shunt is equivalent to that of the 62775 narrow-band shunt.



**Figure 12-12:
Bidirectional Simulation Coupler (62664) Assembly Mounting Dimensions**

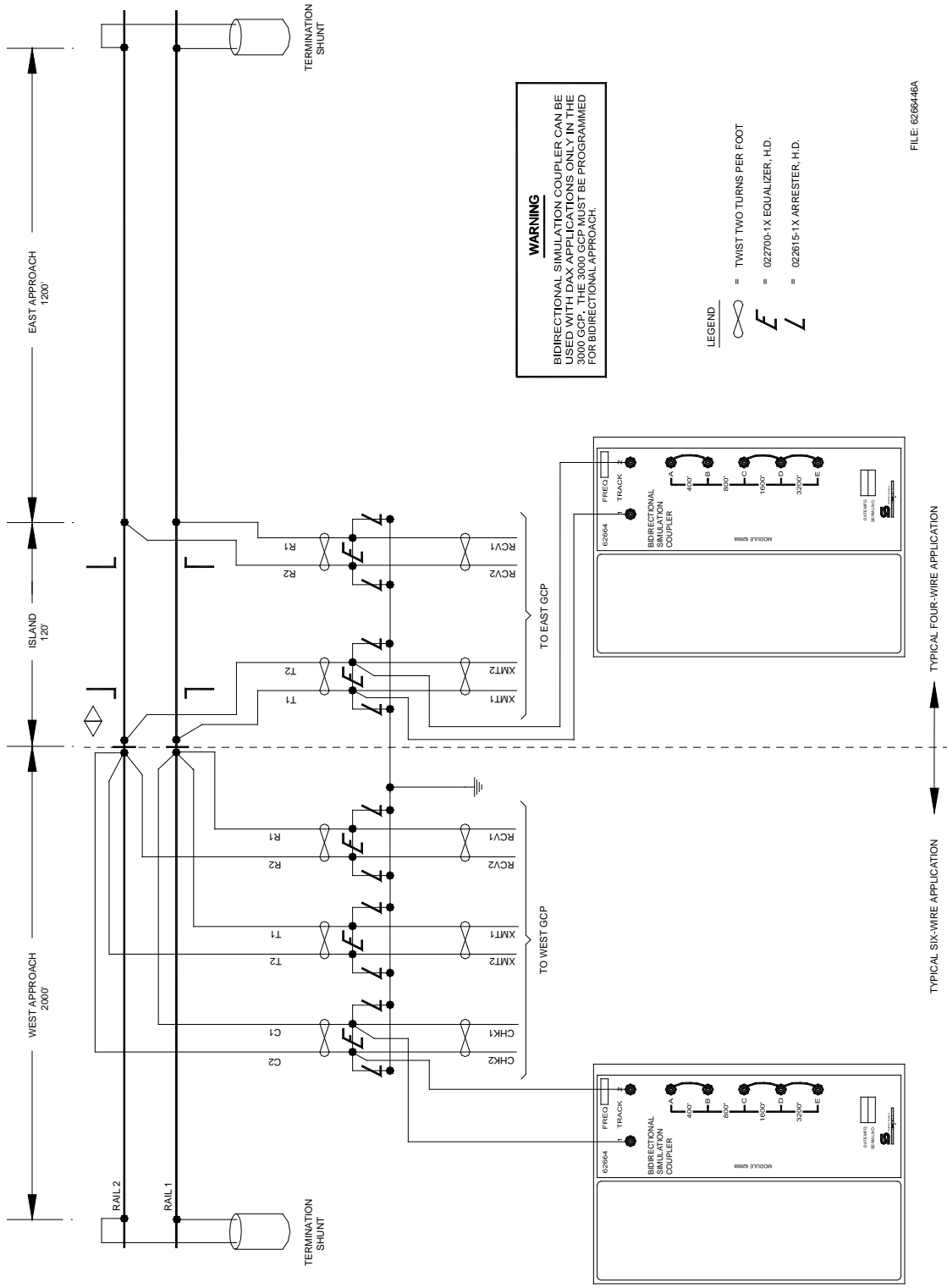
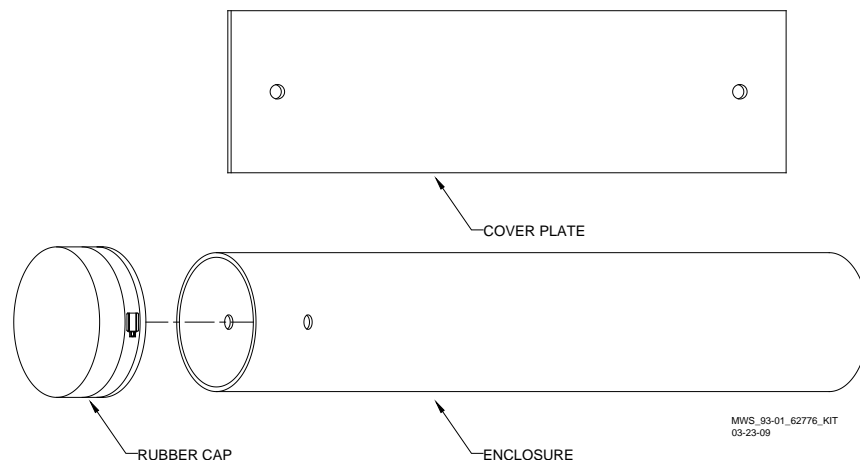


Figure 12-13:
Typical Unidirectional 3000 GCP Installation With Bidirectional Simulation Applied To East Approach

12.3.2 MS/GCP Termination Shunt Burial Kit, A62776



**Figure 12-14:
MS/GCP Termination Shunt Burial Kit, A62776**

MS/GCP Termination Shunt Burial Kit, A62776, (see Figure 12-14) is designed to protect narrow-band termination shunts that are normally buried in the space between adjacent railroad ties. The kit consists of a 26-inch length of 6-inch diameter black PVC tubing and a 7x24-inch ¼-inch thick steel plate. One end of the tubing is fitted with a pliable rubber cap that is secured in place by an adjustable stainless steel clamp. Two 5/8-inch diameter holes located near the capped end of the tube accommodate the shunt leads.

**Table 12-12:
Dimension Data for MS/GCP Termination Shunt Burial Kit, A62776**

PARAMETER	VALUES
Enclosure (PVC)	
Length	24.0 inches (60.96 centimeters) without end cap
Diameter	6.0 inches (15.24 centimeters) Inside Diameter
Thickness	0.1875 inches (0.47625 centimeters)
Cover Plate (Steel)	
Height	24.0 inches (60.96 centimeters)
Width	7.0 inches (15.24 centimeters)
Thickness	0.25 inches (0.60 centimeters)
Weight	
Enclosure	5 pounds (11.02 kilograms) (approximate)
Cover Plate	12 pounds (26.45 kilograms) (approximate)

The enclosure is normally buried in a vertical position between the ties. The termination shunt is lowered into the enclosure and the two leads routed through the holes in the enclosure wall and connected to the rails using standard procedures. The cap is then secured over the top of the enclosure using the stainless steel clamp. The steel plate is centered over the buried enclosure/shunt and securely fastened to each tie using the two 1/4x3-inch lag bolts provided. See Table 12-12 for dimensional data.

12.3.3 Six-Wire Simulated Track Burial Assembly, 80074

The 80074 Six-wire Simulated Track Burial Assembly is used in six track wire applications only and ensures proper operation of the 3000 GCP self-check circuits if a train stops at or very near the track wire feed points.

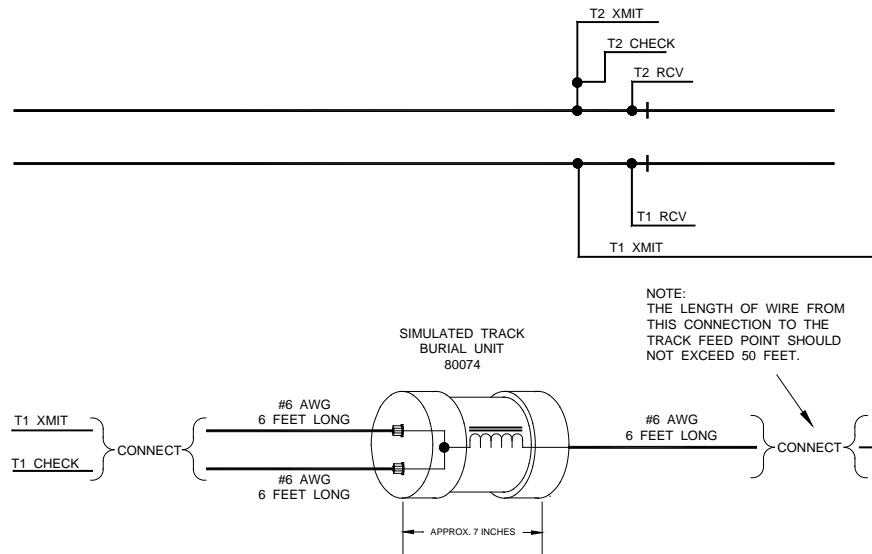
The unit is connected between the transmit and check channel receiver track wires and the associated rail as shown in Figure 12-15. Once connected it is buried beside the tracks.



CAUTION

THE BURIAL ASSEMBLY SHOULD BE CONNECTED AS CLOSE AS PRACTICABLE TO THE RAILS (WITHIN 10 FEET) AND, TO AFFORD MAXIMUM PROTECTION FROM PHYSICAL DAMAGE, BE ENCASED IN A PROTECTIVE ENCLOSURE OR BURIED (EITHER VERTICALLY OR HORIZONTALLY) AT AN APPROPRIATE DEPTH. IT IS NOT NECESSARY TO BURY THE ASSEMBLY BELOW THE FROST LINE. THE LENGTH OF THE SINGLE NUMBER 6 AWG LEAD FROM THE SIMULATED TRACK BURIAL ASSEMBLY TO THE TRACK FEED POINT SHOULD NOT EXCEED 25 FEET.

A typical 3000 GCP six-wire unidirectional installation operating in the unidirectional mode and using the Track Burial Assembly is shown in Figure 12-15.



**Figure 12-15:
Six-wire Simulated Track Burial Assembly, 80074**

12.3.4 DC Shunting Enhancer Panel, 80049



WARNING

DO NOT CONNECT THE DC SHUNTING ENHANCER PANEL TO THE 3000 GCP UAX (UAX1) TERMINALS IF OTHER WIRES ARE ALREADY CONNECTED TO THESE TERMINALS. IF THIS CONDITION EXISTS, CONTACT SAFETRAN ENGINEERING AT 1-800-793-7233 BEFORE PROCEEDING.

Intermittent poor shunting can result just about anywhere due to numerous causes, but generally occurs due to:

- infrequent track usage

AUXILIARY EQUIPMENT

- lightly weighted cars
- passenger and transit operation
- spillage from rail cars
- rail contamination

Lack of any shunting generally occurs in dark territory where no DC or AC track circuits exist and few trains run.

Track shunting in dark territory can be easily improved using methods similar to those employed in style-C track circuits (but without the need for so many insulated joints). This involves the:

- use of one insulated joint at the far end of each approach
- application of a DC voltage to the track at the crossing

These measures improve shunting, thus allowing the 3000 Enhanced Detection software to function reliably.

The Safetran 80049 DC Shunting Enhancer Panel, Figure 12-16, applies a nominal 6 volts DC to the track at the crossing to break down any insulating film that may develop on the rails. This DC voltage is isolated from battery and is generated from:

- 110 volt AC step-down transformer when AC is present
- Battery powered DC-to-DC converter when AC is off.

The panel switches automatically to the DC-to-DC converter output if AC fails. The 3000 GCP UAX input monitors the presence of 6-volt DC. Two insulated joints are required to confine the 6 volts on the track with one placed at the far end of each GCP approach.

The DC Shunting Enhancer Panel can easily be incorporated into applications involving overlapping approaches from two or more crossings without the use of additional insulated joints as shown in Figure 12-17.

Narrow-band termination shunts must be used in all applications of the 80049 panel, since wideband and hardwire shunts negate the purpose of the panel.

The 80049 panel can be rack, wall, or shelf mounted. See Figure 12-16 for mounting dimensions.

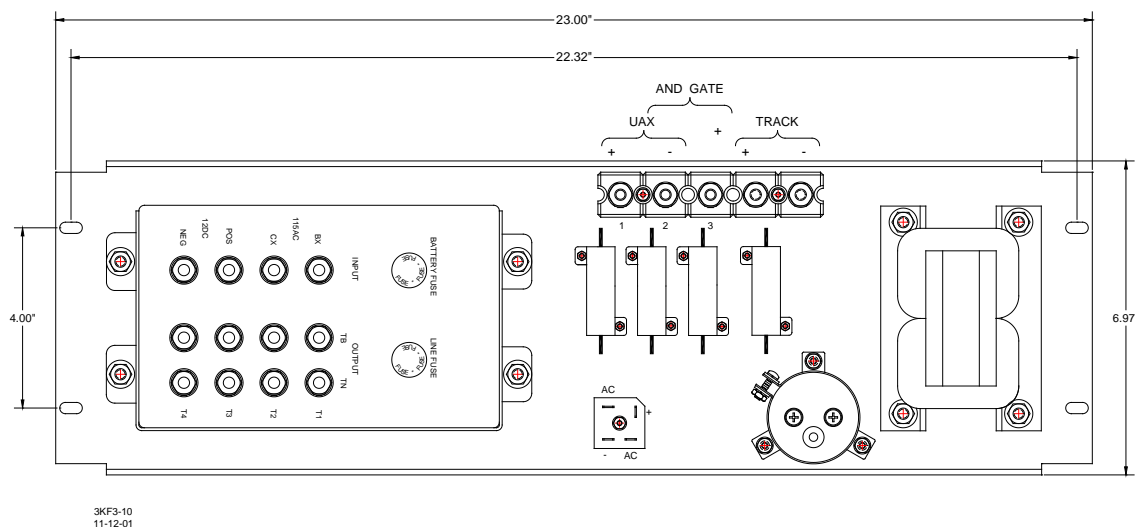


Figure 12-16:
DC Shunting Enhancer Panel, 80049

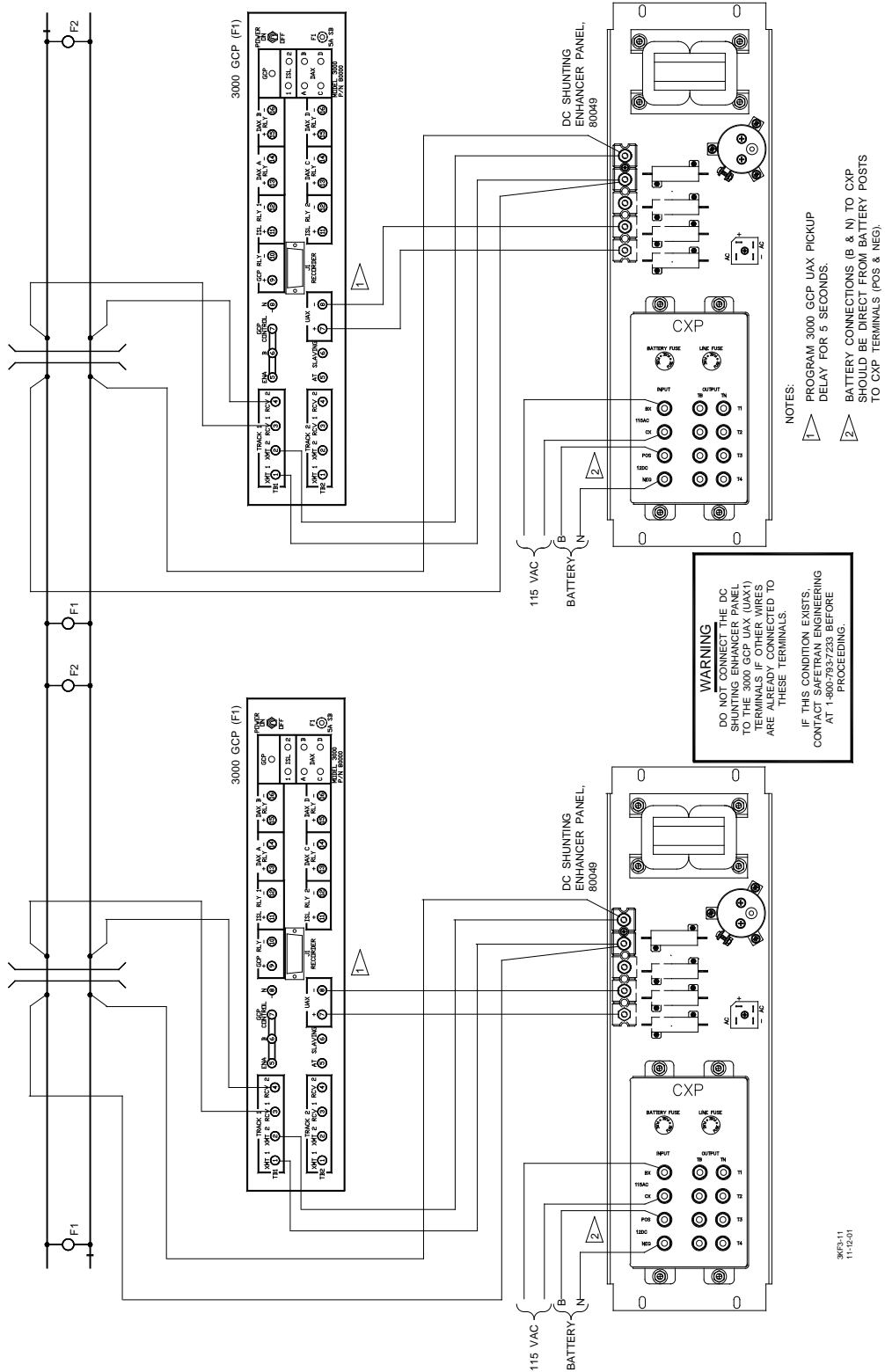
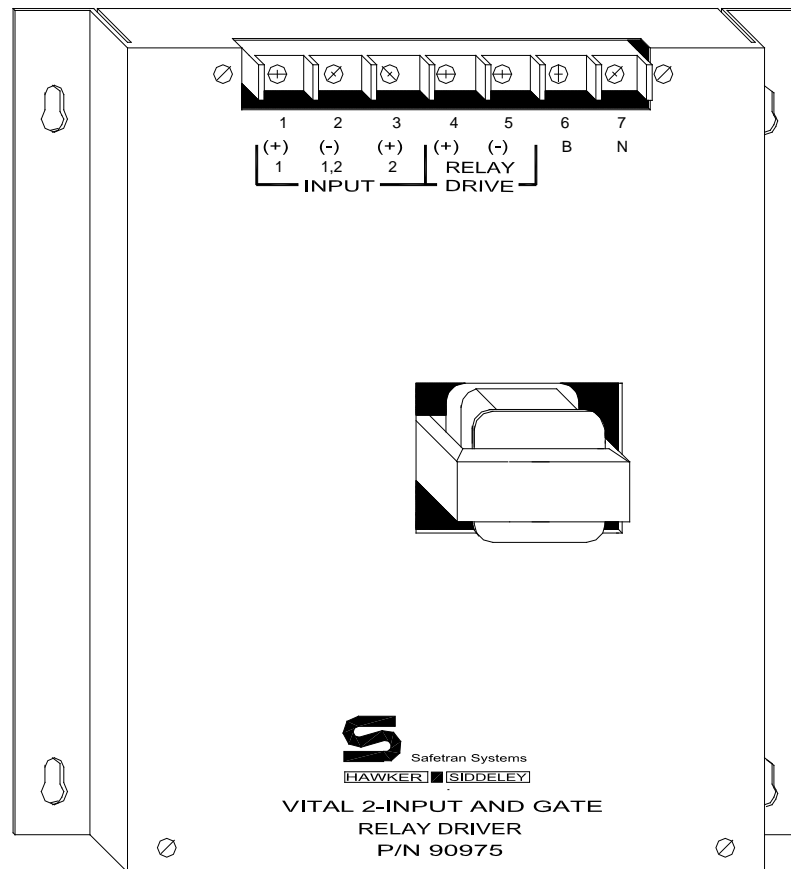


Figure 12-17:
DC Shunting Enhancer Panel, 80049, Typical Application With Overlapping Track Circuits

12.3.5 Vital AND-Gate, 2-Input 90975

The solid-state Vital 2-Input AND-gate, 90975 (see Figure 12-18), is a logic device that combines two inputs to produce a single output. The AND-gate output is energized only when both inputs are energized. The solid-state vital AND-gate inputs and output are electrically isolated from battery (B and N) within the unit.

This device is designed for applications such as cascading the outputs from two separate devices into the single input of a third device. The vital AND-gate eliminates the need for external relays which are normally used to accomplish this function. The unit is housed in a brushed aluminum case which can be installed in any convenient location within the wayside enclosure. A typical application using the vital AND-gate with the 3000 GCP is described in the following paragraphs and is illustrated in Figure 12-19.



FILE: 90975A

**Figure 12-18:
Vital AND-Gate, 2-Input, 90975**

In the example illustrated in Figure 12-19, streets A, B, and C, are 500 feet apart. Each crossing is protected by two unidirectional 3000 GCPs (or a single GCP case with two transceiver modules) with a set of insulated joints located on one side of the street that electrically isolate the two GCP systems. The insulated joints cannot be bypassed with couplers of any type. Therefore, since the approach distance between adjacent crossings is not sufficient to provide the operating time required, and the approach cannot be extended by passing the GCP frequency around the insulated joints with bypass couplers, the controls can be extended by adding a DAX Module (80016) to each GCP. Each 3000 GCP case can accommodate up to two DAX modules and each module is equipped with two DAX prediction circuits, providing a total of four independent DAX outputs.

To provide 30 seconds operating time at a maximum train speed of 30 miles-per-hour, the approach distance required in the example would be 1,496 feet (30 seconds warning time plus 4 seconds system response time multiplied by 44 feet per second equals 1,496 feet). Therefore, to provide adequate crossing start distance for both eastbound and westbound trains, two DAX circuits are required in GCP number 1 at street A, one DAX circuit each in GCPs 1 and 2 at street B, and two DAX circuits in GCP 2 at street C.

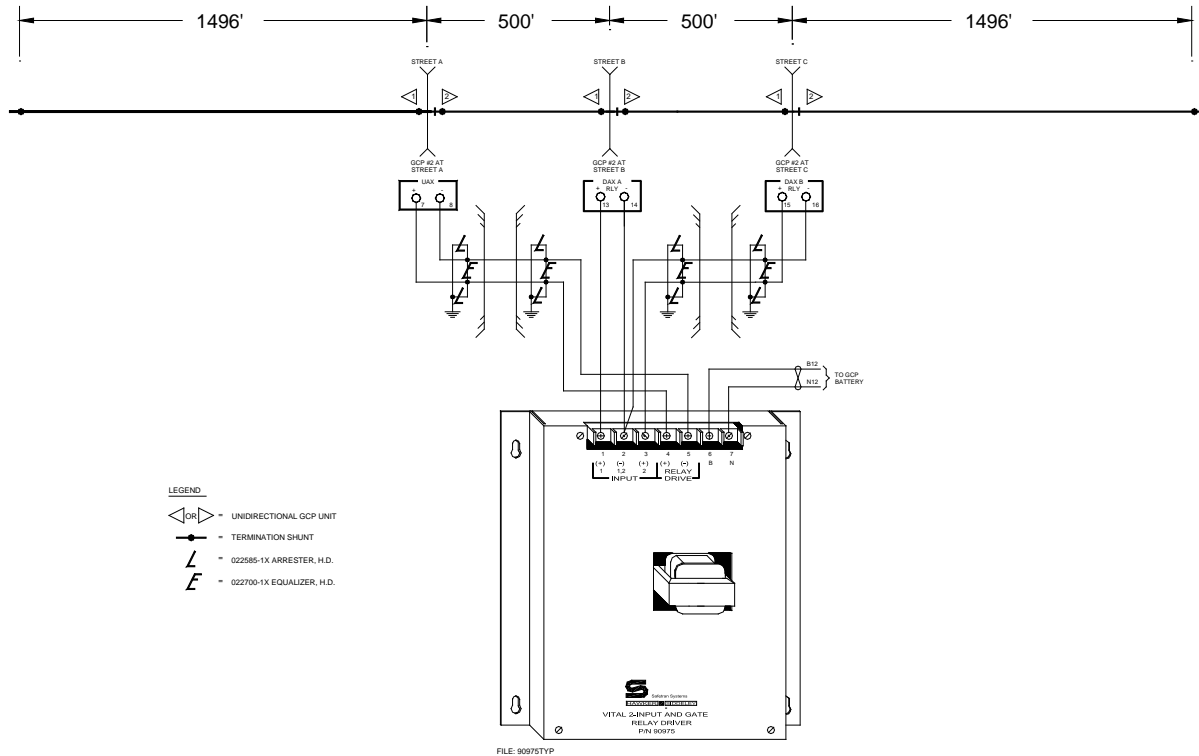


Figure 12-19:
Typical Solid-state Vital And-Gate Application

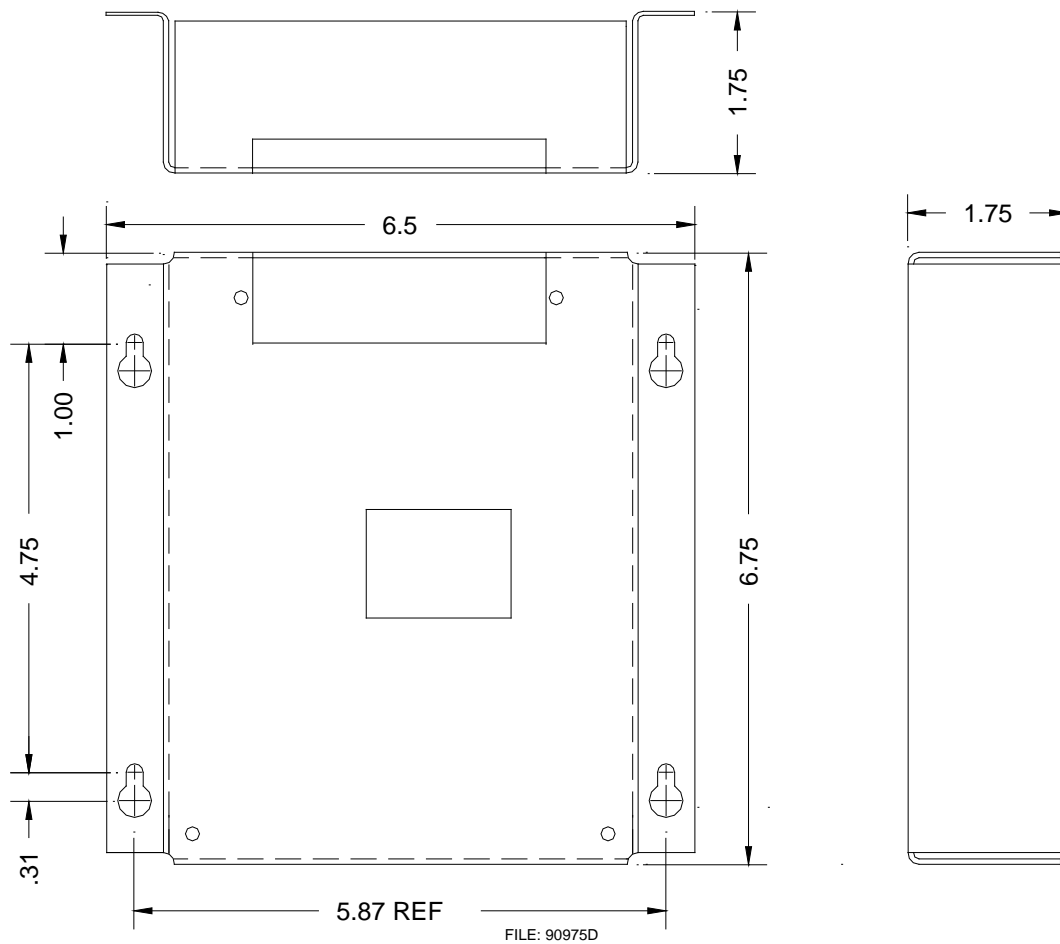
Downstream adjacent crossing (DAX) control requires a line circuit (open line or cable) between the GCP with the DAX module and the GCP receiving the normally-energized DAX output (applied to UAX terminals). In the example, the number 2 GCPs at streets B and C are both supplying a DAX output to the single UAX input on GCP 2 at street A. This is accomplished by applying the two DAX outputs to the inputs on a vital AND-gate. The single output from the AND-gate is then connected to the UAX terminals on GCP 2 at street A.

To illustrate DAX control for street A, consider a westbound train approaching street C at 30 miles-per-hour. When the train is 30 seconds from street A, the DAX B circuit in GCP 2 at street C predicts and removes relay drive from the front panel DAX B relay drive (RLY + and -) terminals. The line circuit from these terminals extends to the vital AND-gate at street B. When energy is removed from the vital AND-gate input, the line circuit from street B (AND-gate output) to the UAX input on GCP 2 at street A is also deenergized. Removing energy from the UAX terminals de-energizes the front panel GCP RLY (relay drive) terminals on GCP 2 at street A, causing the warning signals to operate. When the train crosses the insulated joints at street C, GCP 2 at street B 'picks up' the train, causing DAX A in that unit to predict and deenergize the DAX A front panel terminals on that unit (second input to vital AND-gate). This ensures that the line circuit to the GCP UAX terminals on GCP number 2 at street A remains deenergized (the vital AND-gate output will be energized only when both inputs to the AND-gate are energized).

See Figure 12-20 for solid-state vital AND-gate assembly mounting dimensions.

**Table 12-13:
Data Recorder Interface Assembly Specifications**

PARAMETER	VALUES
Power Input	
Voltage	9.5 to 16.5 VDC
Current	200 milliamperes
Output	12 VDC (nominal); will drive 200 to 1,000-ohm loads
Control Inputs	7 to 18 VDC (1,000-ohm input resistance)
Input/Output Protection	Floating (optically coupled and transformer coupled); surge protected
Dimensions	
Height	6.25 inches (15.9 centimeters)
Width	6.25 inches (15.9 centimeters)
Depth	2.5 inches deep (6.4 centimeters)
Weight	1 pounds (0.45 kilograms) (approximate)



**Figure 12-20:
Solid-state Vital Gate Assembly Mounting Dimensions**

12.3.6 Vital AND-Gate, 4-Input, 91082

The Vital AND-Gate, 4-Input, 91082, (Figure 12-21) is a logic device that combines four DC inputs to produce a single DC output.

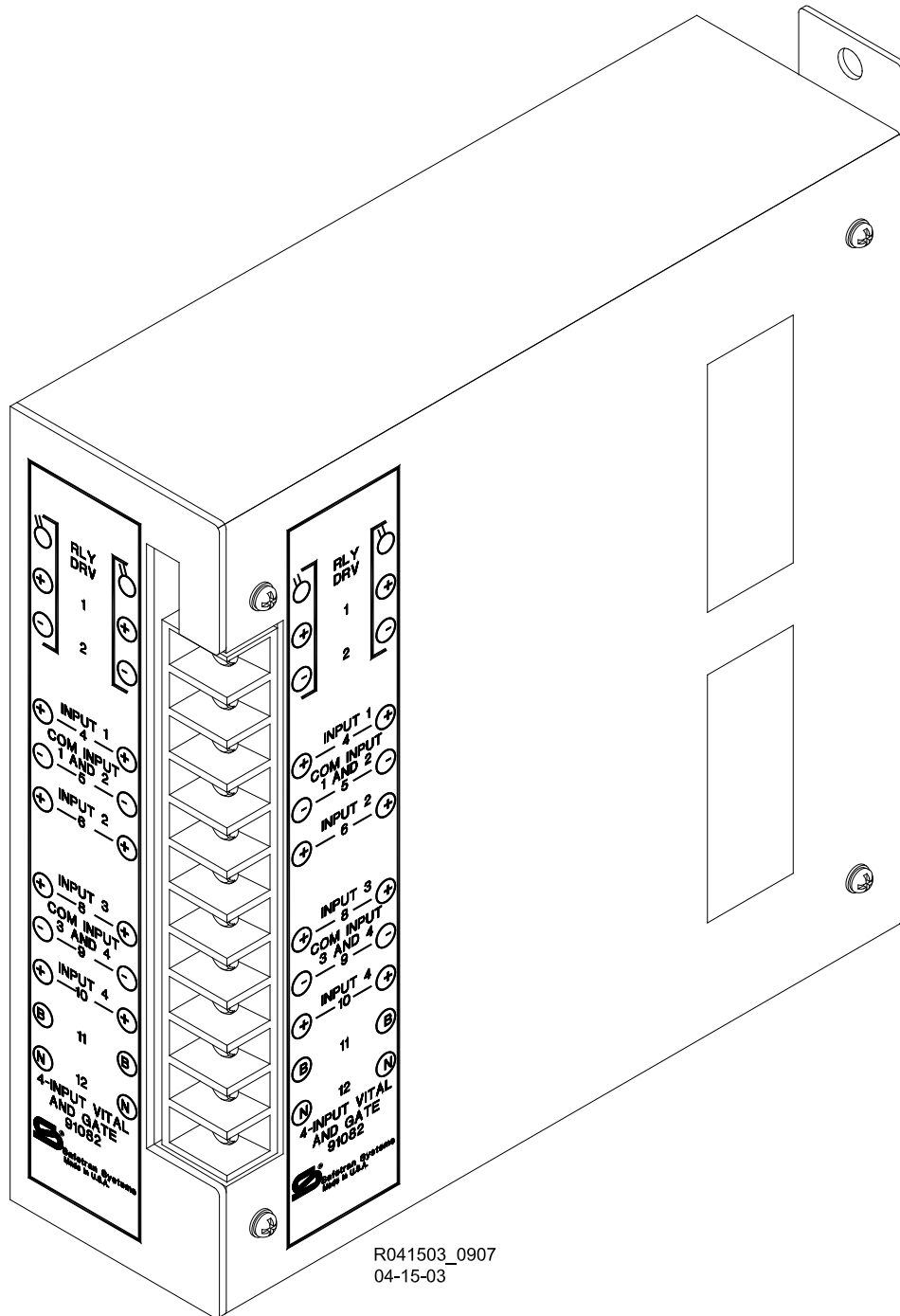


Figure 12-21:
Vital AND Gate, 4-Input, 91082

The Vital AND-Gate, 4-Input, 91082, combines four inputs to produce a single output. When a relay drive voltage is applied to all of the AND gate inputs, the drive voltage appears at the **RLY DRV** output of the gate. When the drive voltage is removed from any one of the AND gate inputs, voltage is removed from the **RLY DRV** output.

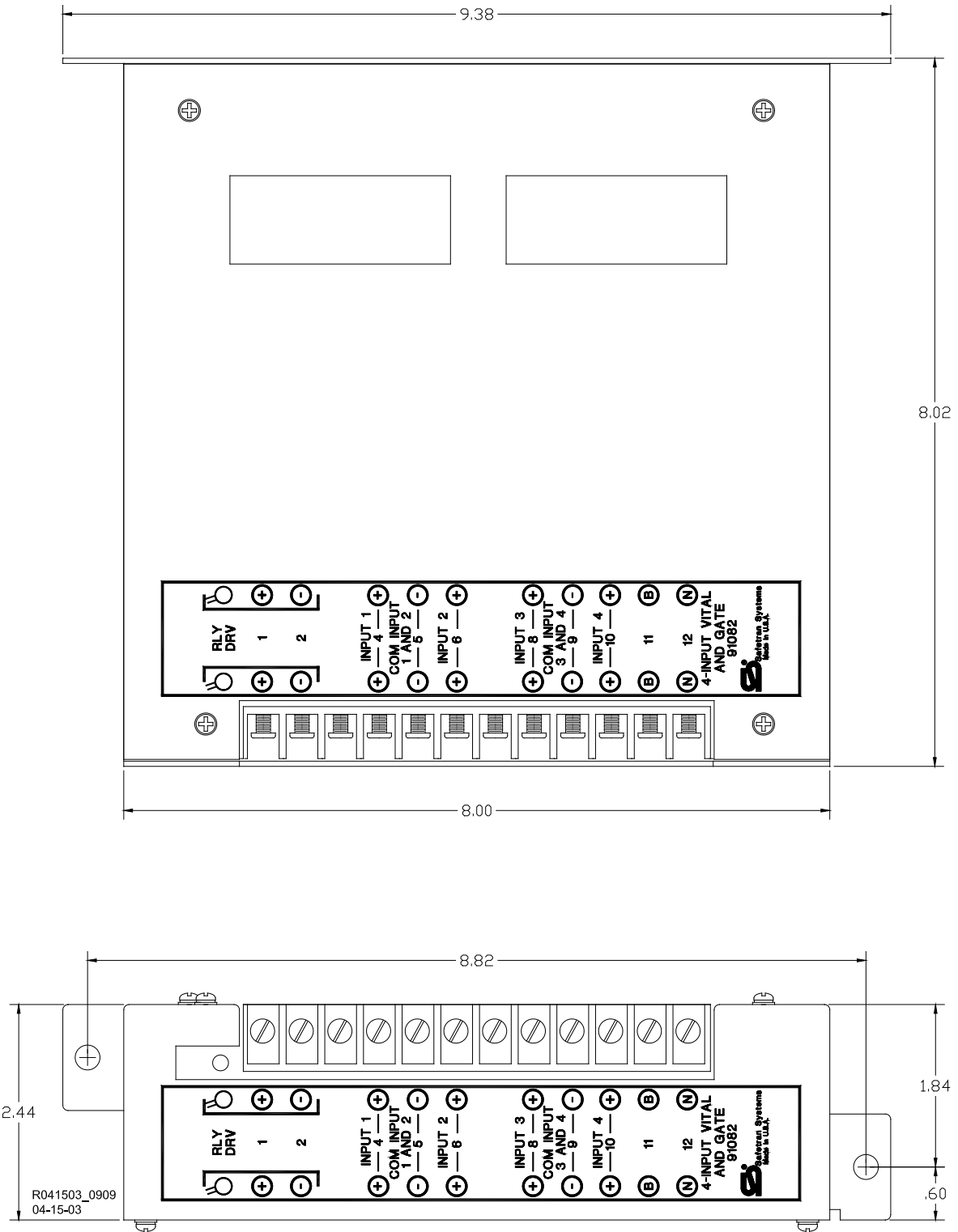
NOTE

NOTE

The inputs and outputs are electrically isolated from battery (B and N) within the unit.

**Table 12-14:
4-input Vital AND Gate, 91082**

PARAMETER	VALUES
Environmental Temperature Range:	-40 °F to +160 °F (-40 °C to +71 °C)
Dimensions:	9.38 inches (87.89 centimeters) high 2.44 inches (20.37 centimeters) wide 8.02 inches (20.37 centimeters) deep
Weight:	4.06 pound (1.8 kilogram) (approximate)
Power Input:	
Voltage:	9.5 to 16.5 VDC
Current:	200 milliamperes
Output Voltage:	12 VDC (nominal); will drive 400 to 1,000-ohm loads
Control Inputs:	7 to 18 VDC (1,000-ohm input resistance)
Input/Output Protection:	Floating (optically isolated and transformer coupled); surge protected
Mounting Dimensions	The 4-input Vital AND Gate is housed in a brushed aluminum case designed for shelf or backboard mounting. The unit mounting dimensions are provided in Figure 12-22.



**Figure 12-22:
4-input Vital AND Gate Assembly Mounting Dimensions**

12.4 TRACK CIRCUIT ISOLATION DEVICES

NOTE

NOTE

As there are a number of variations in DC coded track such as relay type and associated operating current, decoding method, current and voltage transmitted and received, track circuit length, transmit and receive code polarity, DC code frequency, pulse width, etc., the recommendations presented in the following paragraphs are general in nature and no attempt has been made to cover all applications.

Battery chokes and code isolation devices described are designed for mounting inside a weatherproof enclosure.

If there are any questions concerning these recommendations or applications, contact Safetran Application Engineering for assistance.

Several types of track circuit isolation devices are available for both DC and AC coded track applications. Also, as additional field experience is gained, improved or changed application methods may result.

The following discussions are grouped by coded track circuit type.

12.4.1 Steady Energy DC Track Circuits

All DC track circuits with batteries located within a 3000 GCP approach, or less than 2,000 feet beyond the approach termination, should be equipped with a battery choke. Either of the following battery chokes may be used in Steady Energy DC Track Circuits:

- Part number 8A065A
- Part number 62648 (see limitations in following paragraphs).

However, if the track connections for the DC track circuit are 2,000 feet or more beyond the GCP approach termination shunt, a battery choke is not required (see Figure 12-23).

WARNING

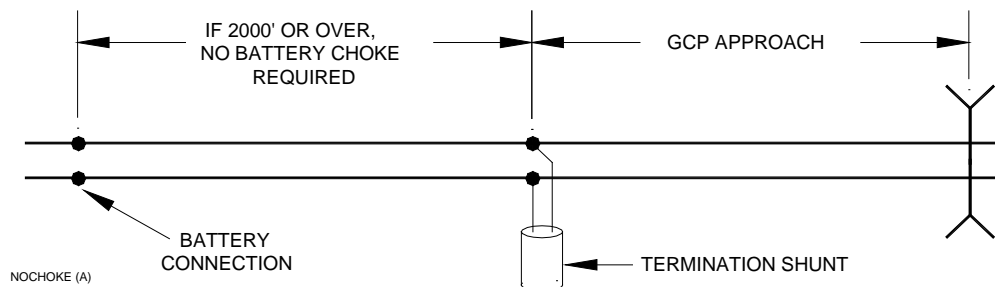
WARNING

IN APPLICATIONS WHERE THE CHOKE IS LOCATED WITHIN A MODEL 300 OR 400 GCP APPROACH, THE 8A065A BATTERY CHOKE MUST BE USED.

NOTE

NOTE

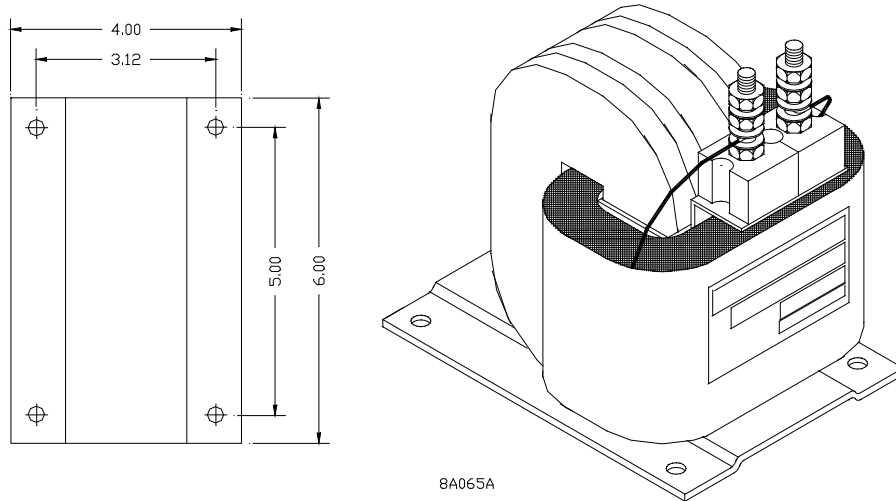
Operation of long DC track circuits with very low ballast conditions may be affected by the DC resistance (DCR) of the 8A065A battery choke, which has a DCR of 0.40 ohm. Such track circuits should use the 62648 battery choke, which has a DCR of 0.10 ohm and 5 mH of inductance.



**Figure 12-23:
Battery Choke Requirements**

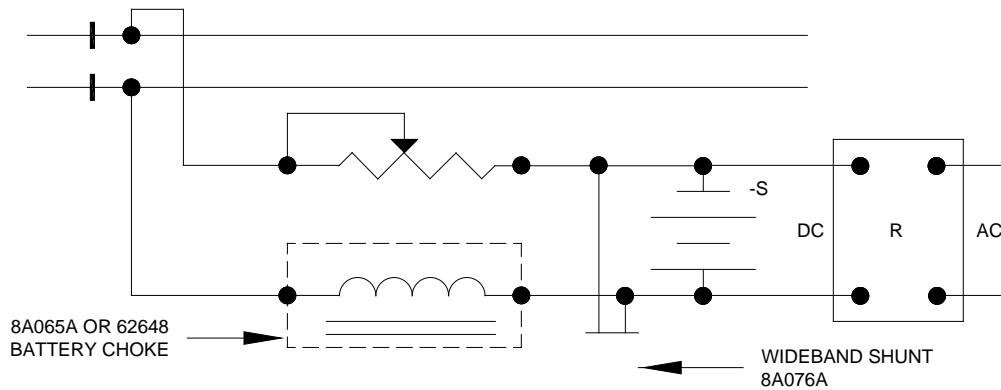
12.4.1.1 Battery Chokes, 62648 & 8A065

The 62648 and 8A065A battery chokes each consist of a large inductance coil with two top-mounted AAR terminals and a mounting base (Figure 12-24).



**Figure 12-24:
62648/8A065A Battery Choke With Mounting Dimensions**

When a rectified track circuit is used and the GCP is operating at 114 Hz, an 8A076A wideband shunt (paragraph 12.5.8) should also be used along with the battery choke to eliminate 120 Hz ripple. Figure 12-25 illustrates this application.



**Figure 12-25:
Ripple Elimination Circuit**

**Table 12-15:
Battery Chokes, 62648 and 8A065, Specifications**

PARAMETER	VALUES
Dimensions	
Height	8.5 inches (21.59 centimeters)
Width	4.50 inches (11.43 centimeters)
Depth	5.0 inches (12.7 centimeters)
Weight	17 pounds (7.72 kilograms) (approximate)

12.4.2 Safetran GEO Electronic DC Coded System

The standard Safetran 3000 GCP frequencies of 86 Hz and above are compatible with GEO. Isolation circuits are generally not required in the GEO transmitter rail connections. GCP Frequencies of 86, 114, 156, and 211 Hz require use of maximum current, track devices, and the GEO Track Noise Suppression Filter, A53252. The GEO Filter must be installed at the signal location for the above mentioned frequencies.

12.4.3 Electro Code Electronic Coded System

Model 3000 GCP frequencies of 86 Hz and above can normally be used with Electro Code. All frequencies of 211 Hz and lower require use of maximum current track drive. In certain instances, 285 Hz may also require maximum current.

For frequencies of 211 Hz and lower, an Electro Code track filter (TF-freq) may be required when the Electro Code transmitter is located within the 3000 GCP approach. As with any coded track system, the lower the Electro Code transmit level, the less interference with GCP units.

12.4.4 Relay Coded DC Track

12.4.4.1 DC Code Isolation Units, 6A342-1 & 6A342-3

Most relay coded DC track installations require use of DC code isolation units such as the 6A342-1 (Figure 12-26). A code isolation unit is a special battery choke that aids in preventing coded track battery and track relays from causing high interference with the 3000 GCP.

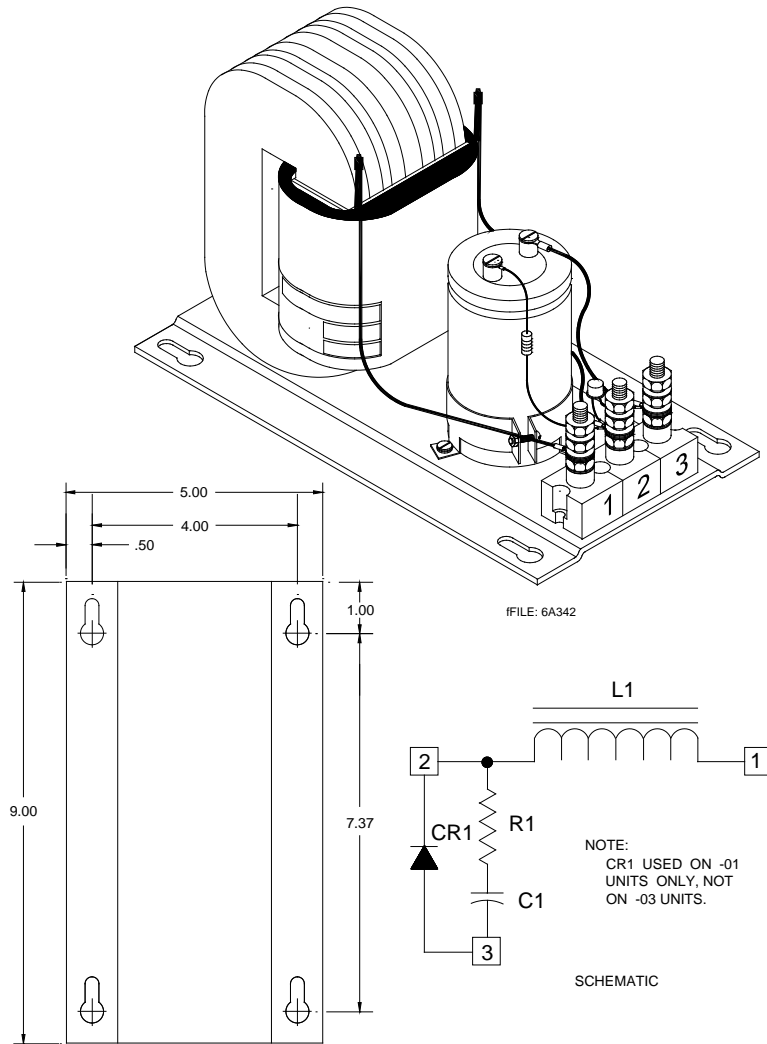
WARNING

WARNING
**ALWAYS VERIFY PROPER CODE SYSTEM OPERATION AFTER
 INSTALLING THE ISOLATION UNIT.**

NOTE

NOTE
 The correct model code isolation unit for the type of DC coded track circuit used must be installed as instructed in these guidelines.

The 6A342-1 DC code isolation unit is used in most single polarity code systems while the 6A342-3 unit is used in GRS Trakode (dual polarity) relay systems. The only difference between the two units is that 6A342-1 is internally wired to CR1, while the 6A342-3 is not (see note in Figure 12-26).



**Figure 12-26:
DC Code Isolation Unit, 6A342-01, With Mounting Dimensions**

All wiring to terminals 1 and 2 on the isolation units should be number 6 AWG. This significantly reduces current losses to the track relay during low track ballast conditions. Frequencies below 211 Hz require maximum current.

**Table 12-16:
Battery Choke, 6A342 Specifications**

PARAMETER	VALUES
Dimensions	
Height	5.75 inches (14.6 centimeters)
Width	5.0 inches (12.752 centimeters)
Depth	9.0 inches (22.86 centimeters)
Weight	15 pounds (6.81 kilograms) (approximate)

Various applications for the track isolation units are discussed in the paragraphs that follow.

12.4.5 Single Polarity Systems (Fixed Polarity)

The 6A342-1 code isolation unit can be used in most single (fixed) polarity code systems. A single polarity code system must have the same received and transmitted polarities to use this code isolation unit. Most rate code systems (75, 120, and 180 ppm) are of this type. Figure 12-27 illustrates a typical 6A342-1 code isolation unit installation in a single polarity code system.

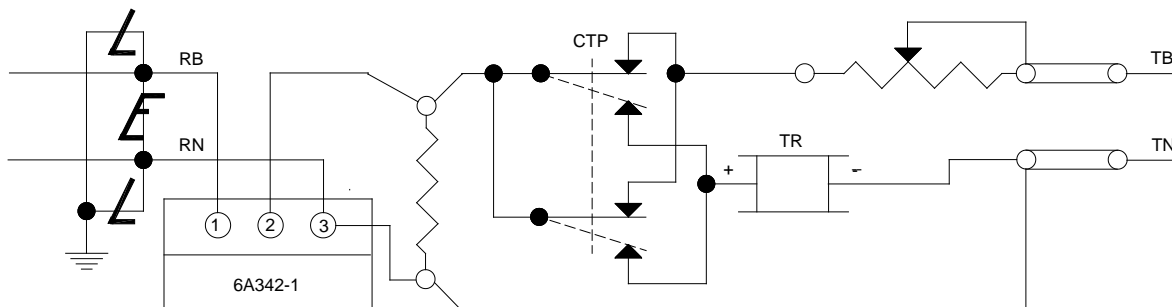


Figure 12-27:
Typical 6A342-1 Code Isolation Unit Installation in a Single Polarity Code System

12.4.6 GRS Trakode (Dual Polarity) Systems

Figure 12-28 illustrates the 6A342-3 code isolation unit installed in a GRS Trakode system. To install the unit as shown, a transfer delay (TD) relay must be used. Do not install any code isolation circuit in GRS Trakode without use of the TD relay.

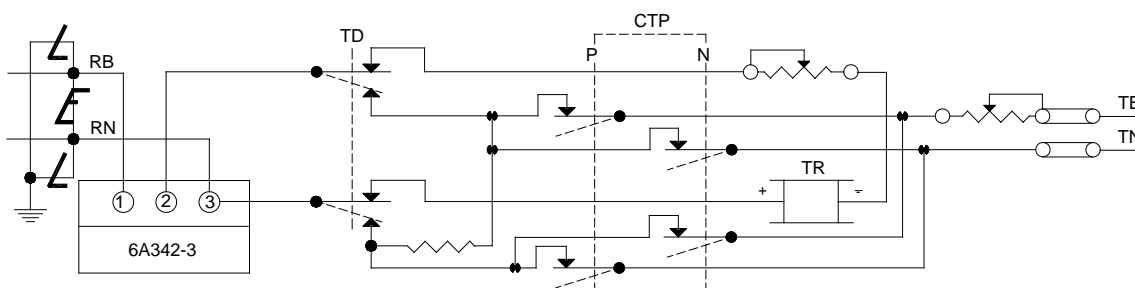


Figure 12-28:
Typical 6A342-3 Code Isolation Unit Installation in a GRS Trakode System

12.4.7 Dual Polarity (Polar) Coded Track Systems Other Than GRS Trakode

A dual polarity system is one in which the received code polarity is opposite that of the transmitted code. The 6A342-3 code isolation unit can be used in a dual polarity system; however, two 6A342-3 units must be specifically placed at each end of the circuit for proper filtering. The application will depend upon the track circuit configuration. Contact Safetran Application Engineering for assistance in dual polarity code systems.

12.4.8 AC Cab Signal

Application of 3000 GCP systems in cab territory using 60 Hz AC Code Isolation Unit, 8A466-3 (Figure 12-29), or 100 Hz Isolation Unit, 8A471-100 (Figure 12-32), is shown below. For other installations, contact Safetran Application Engineering for assistance.

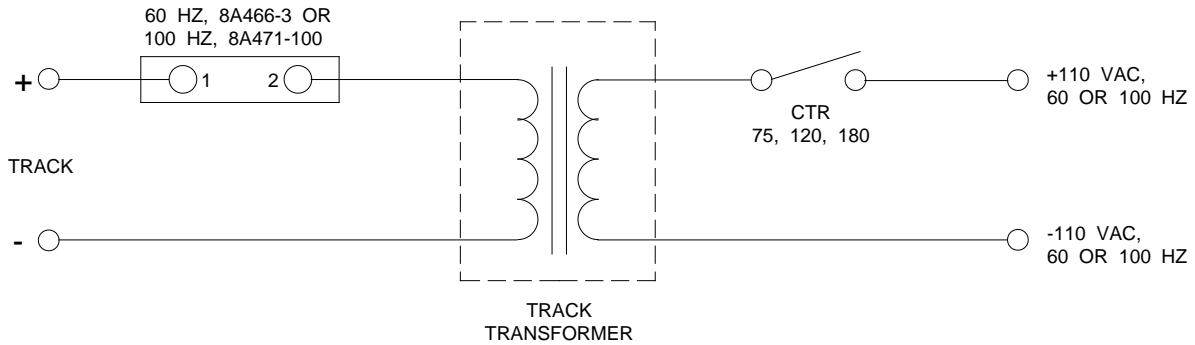


Figure 12-29:
Typical AC Code Isolation Unit Installation Application

12.4.8.1 AC Code Isolation Unit, 8A466

Specifications for the AC Code Isolation Unit, 8A466 (Figure 12-30) are as follows:

Table 12-17:
60 Hz AC Code Isolation Unit, 8A466-3 Specifications

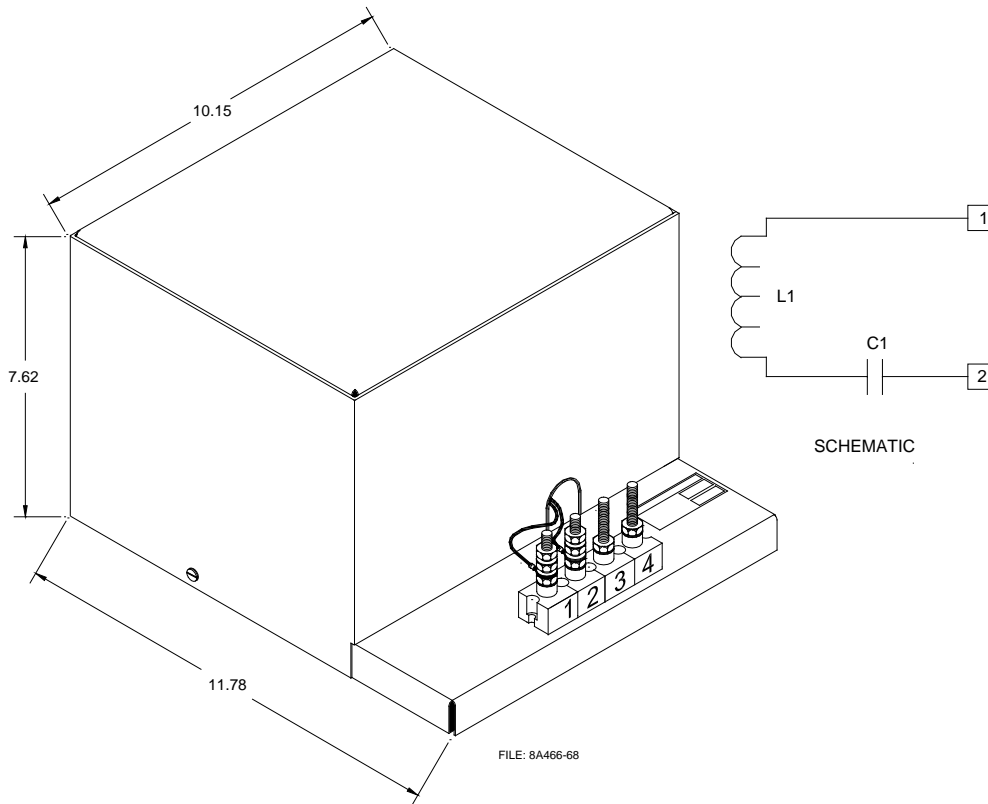
PARAMETER	VALUES
Dimensions	
Height	7.62 inches (19.35 centimeters)
Width	10.15 inches (25.78 centimeters)
Depth	11.78 inches (29.92 centimeters)
Weight	26 pounds (11.8 kilograms) (approximate)

12.4.8.2 AC Code Isolation Unit, 8A471-100 & 8A471-180

Specifications for the AC Code Isolation Unit, 8A471-100, (Figure 12-32) are as follows:

Table 12-18:
100 Hz AC Code Isolation Unit, 8A471-100 Specifications

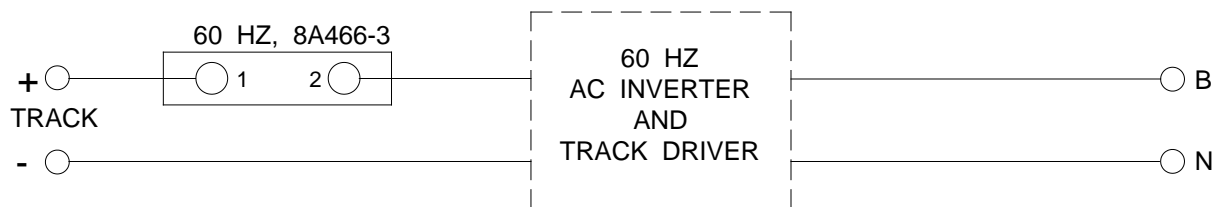
PARAMETER	VALUES
Dimensions	
Height	9.0 inches (22.86 centimeters)
Width	5.0 inches (12.70 centimeters)
Depth	9.4 inches (23.88 centimeters)
Weight	5 pounds (2.27 kilograms) (approximate)



**Figure 12-30:
AC Code Isolation Unit, 8A466**

12.4.9 Style C Track Circuits

The 60-Hz AC code isolation unit (8A466-3) (Figure 12-31) is used with style C track circuits as shown below. For special applications, 180-Hz AC code isolation unit (8A471-180) (Figure 12-32) is also available. Contact Safetran Application Engineering for specific information.



**Figure 12-31:
60 Hz AC Code Isolation Unit Installation in Style C Track Circuit**

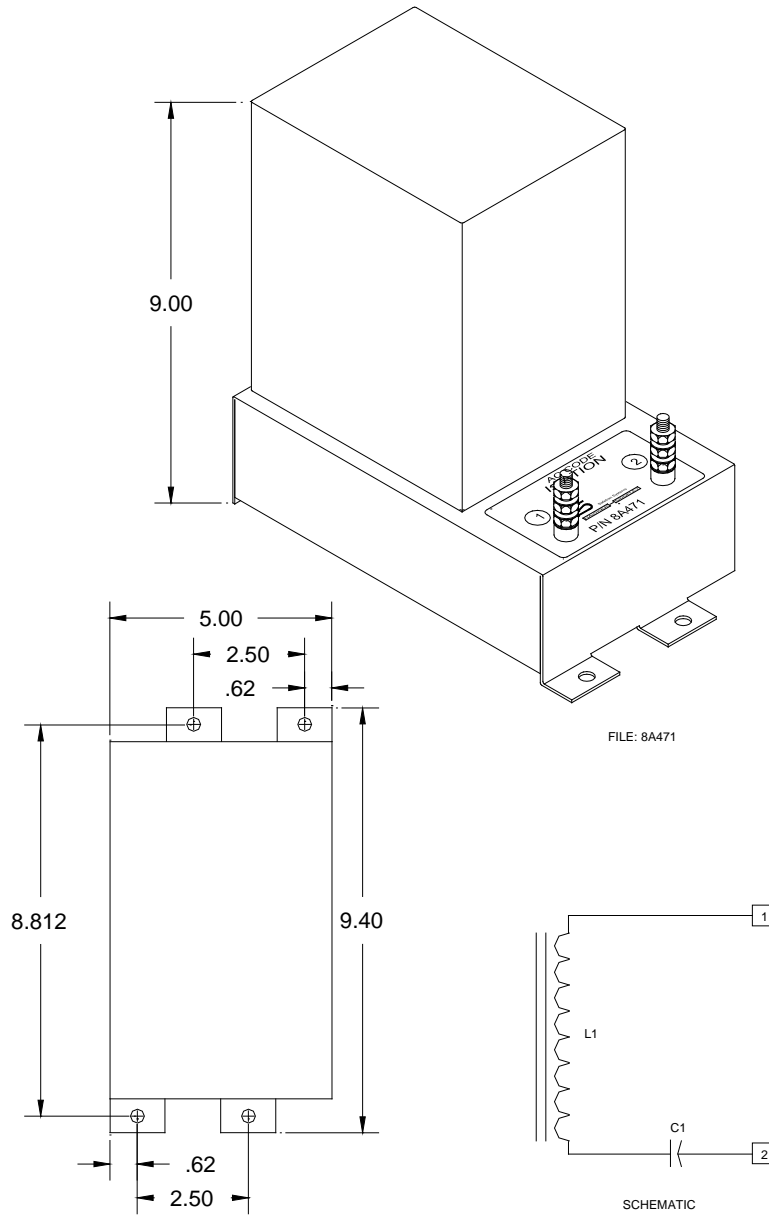


Figure 12-32:
180 Hz AC Code Isolation Unit, 8A471-100 & -180, With Mounting Dimensions

Table 12-19:
180 Hz AC Code Isolation Unit, 8A471-100 & -180 Specifications

PARAMETER	VALUES
Dimensions	
Height	9.0 inches (22.86 centimeters)
Width	5.0 inches (12.70 centimeters)
Depth	9.4 inches (23.88 centimeters)
Weight	5 pounds (2.27 kilograms) (approximate)

12.5 COUPLERS AND SHUNTS

12.5.1 Tunable Insulated Joint Bypass Coupler, 62785-F

Tunable Insulated Joint Bypass Coupler, 62785-f, is designed to replace the earlier fixed-frequency 62531-f and 62631-f insulated joint bypass couplers and must be used in all Model 3000 GCP applications; not the 62531-f and 62631-f couplers. The tunable insulated joint bypass coupler is field tuned to pass the 3000 GCP frequency (f) around insulated joints in DC coded track circuits. As a general rule, a maximum of two sets of insulated joints in each approach can be bypassed using tuned couplers. See Table 12-20 for minimum distance requirements.

**Table 12-20:
Minimum Distance to Insulated Joints When Coupled
With 62785-F Tunable Insulated Joint Bypass Couplers**

FREQUENCY (HZ)	MINIMUM DISTANCE TO FIRST SET OF INSULATED JOINTS (FEET)*	MINIMUM DISTANCE TO SECOND SET OF INSULATED JOINTS (FEET)*
86	N/A	N/A
114	Call Safetran Application Engineering	Call Safetran Application Engineering
151	1500	2200
⇕	⇕	⇕
211	1500	2200
212	1000	1400
⇕	⇕	⇕
348	1000	1400
349	700	1000
⇕	⇕	⇕
560	700	1000
561	500	800
⇕	⇕	⇕
790	500	800
791	400	700
⇕	⇕	⇕
979	400	700

*Distance applies to insulated joints located on the same side of the crossing.

For motion sensor applications only, the 62785-f coupler can also be used when insulated joints are located anywhere within the approach. Field tuning of the coupler enables precise frequency adjustment for track and joint parameters. The 62785-f Tunable Insulated Joint Bypass Coupler is available in standard Safetran frequencies of 156 Hz through 970 Hz.



WARNING

WARNING

INSULATED JOINT BYPASS COUPLERS, 62531-F AND 62631-F, MUST NOT BE USED WITH THE MODEL 3000 GCP. USE INSULATED JOINT BYPASS COUPLER (62785-F) INSTEAD.



CAUTION

CAUTION

CALL SAFETRAN APPLICATION ENGINEERING BEFORE USING THE 114 HZ TUNED INSULATED JOINT BYPASS COUPLER, 62785-114.

The coupler is housed in a sealed, 6-inch diameter, cylindrical case that is 2 inches larger in diameter than the 62531-f and 62631-f couplers. A pair of 10-foot number 6 AWG leads extend from one end and nine AAR terminals extend from the other (see Figure 12-33). Five of the terminals (labeled A through E) are equipped with special gold nuts that are used to tune the coupler. With a hard wire shunt placed across the tracks first on one side of the coupler and then on the other, one or more of the nuts is/are tightened to obtain the minimum change in EZ/ED value. Tightening the nut on terminal A produces minimum change in EZ/ED value while tightening the nut on terminal E produces maximum change. When adjustment is complete, a second AAR nut on each of the terminals is used to lock the adjusting nuts in position. An equalizer and a gas tube arrester are connected to the remaining AAR terminals to provide complete surge protection. A pliable end cap is secured in place over the terminal end of the coupler by a sturdy stainless steel clamp, providing protection against moisture.

NOTE

NOTE
Some applications will require tuning using EX/EDX instead of EZ/ED.

The coupler should be connected as close as possible to the rails, but no farther away than the existing leads will permit. To afford maximum protection from physical damage, the coupler should be encased in a protective enclosure or buried. Although it is not necessary to bury the coupler below the frost line, it should be buried (either vertically or horizontally) at least 18 inches below the surface.

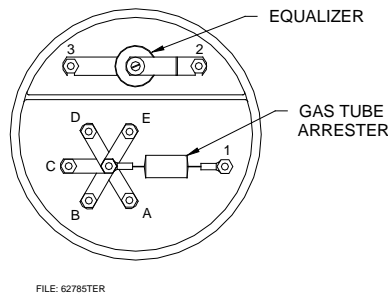


Figure 12-33:
Terminal Identification, 62785-f Tunable Insulated Joint Bypass Coupler

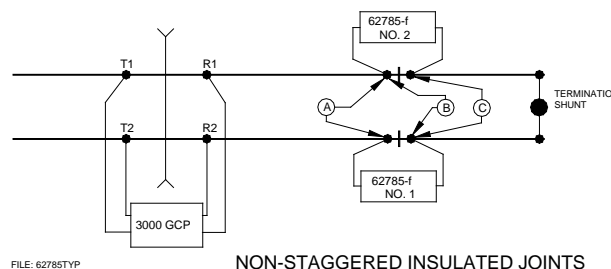
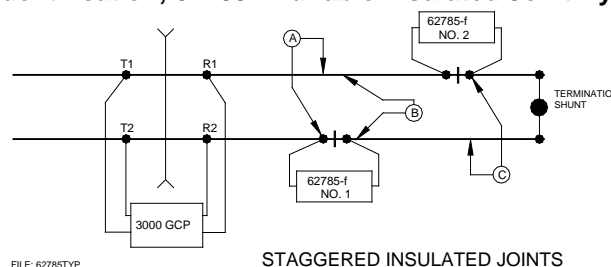


Figure 12-34:
Typical Installation Diagrams Using the Tunable Insulated Joint Bypass (IJB) Coupler, 62785-f

Refer to the appropriate installation diagram in Figure 12-34 for the following tuning procedure.

1. Ensure that the GCP has been properly calibrated using the SETUP pushbutton located on the display panel.
2. Place a hard wire shunt across the tracks at location A and record the EZ value.
3. Move the shunt to the opposite side of the insulated joints at location B and note the change in EZ value.
4. The purpose of this step is to tune the insulated joint bypass coupler to obtain an EZ value that is as close as possible to the value recorded in step 2. On the terminals labeled E, D, C, B, and A, tighten each gold AAR nut in sequence beginning with terminal E. If tightening a nut results in an EZ value that is lower than the value recorded in step 2, loosen the nut and tighten the next nut in sequence. If, after tightening a nut, the EZ value remains higher than the value recorded in step 2, leave the nut tightened and tighten the next nut in sequence until all the nuts (E through A) have been tightened as necessary. The value of EZ should now be nearly the same as that recorded in step 2.
5. Next, move the hard wire shunt to location C on the tracks and repeat step 4 to tune coupler number 2 for the same EZ value obtained in step 4.
6. When EZ values are nearly the same in steps 4 and 5, carefully tighten a standard AAR nut firmly against each gold nut to lock the gold nuts in position.



WARNING

WARNING

ENSURE THAT A STANDARD AAR NUT IS TIGHT-ENED SECURELY AGAINST EACH GOLD NUT ON TERMINALS A THROUGH E, INCLUDING THOSE THAT ARE NOT TIGHTENED DOWN.

7. Recalibrate the GCP and carefully check the smooth change in EZ across the couplers during a train move.

**Table 12-21:
Tunable Insulated Joint Bypass (IJB) Coupler, 62785-f Specifications**

PARAMETER	VALUES
Dimensions	
Height	18.0 inches (45.7 centimeters)
Diameter	6.0 inches (15.2 centimeters)
Weight	12 pounds (5.45 kilograms) (approximate)
Leads	10 feet (304.8 centimeters); number 6 AWG, stranded, black PVC
Surge Suppressor	Equalizer, 022700-21X
Part Numbers	Gas Tube Arrester, Z803-00053-0001

12.5.2 Narrow-Band Shunt, 62775-f

This narrow-band termination shunt is designed for use in areas where other AC frequencies or DC coded track circuits are present, but only the 3000 GCP frequency should be terminated. The shunt requires no special tuning and is generally preferred for most applications.



WARNING

WARNING

THE SHUNT SHOULD NOT BE USED ANYWHERE WITHIN A MODEL 300 OR 400 GCP APPROACH (NARROW-BAND SHUNT, 62780-F, IS RECOMMENDED)

The narrow-band shunt (62775-f) is housed in a hermetically-sealed, cylindrical case with a pair of 10-foot leads extending from one end. The shunt should be connected as close as possible to the rails, but no farther away than the existing leads will permit. To afford maximum protection from physical damage, the

shunt should be encased in a protective enclosure or buried. Although it is not necessary to bury the shunt below the frost line, it should be buried (either vertically or horizontally) at least 18 inches below the surface (see paragraph 12.3.2). The shunt is available in any fixed frequency (Hz) listed below.

**Table 12-22:
Narrow-band Shunt, 62775-f Available Frequencies (Hz)**

86	100	114	151	156	172	210	211	267
285	326	348	392	430	452	522	525	560
630	645	686	753	790	816	881	970	979

**Table 12-23:
Narrow-band Shunt, 62775-f Specifications**

PARAMETER	VALUES
Dimensions	
Height	16.0 inches (40.6 centimeters)
Diameter	5.0 inches (12.7 centimeters)
Weight	10 pounds (4.54 kilograms) (approximate)
Frequencies	See Table 12-22 above
Leads	10 feet (304.8 centimeters); number 6 AWG, stranded, black PVC

12.5.3 Narrow-Band Shunt, 62780-f

Like the 62775-f narrow-band termination shunt (paragraph 12.5.1), the 62780 narrow-band shunt is designed for use in areas where other AC frequencies or DC coded track circuits are present, but only the 3000 GCP frequency should be terminated. However, the 62780 shunt produces less loading effect on adjacent frequencies (10 ohms reactance) than the 62775 shunt and, therefore, can be used in territories with overlapping Model 300 and 400 GCP approaches. The 62780 shunt is compatible with all Safetran motion sensors and GCPs and is available in any of 26 fixed frequencies ranging from 86 to 979 Hz as shown below.

**Table 12-24:
Narrow-band Shunt, 62780-f Available Frequencies (Hz)**

86	100	114	151	156	172	210	211	267
285	326	348	392	430	452	522	525	560
630	645	686	753	790	816	881	970	979

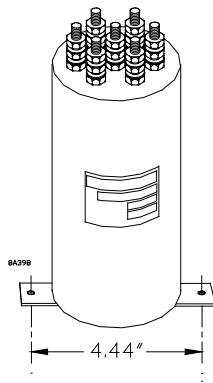
The 62780 narrow-band shunt is housed in a hermetically-sealed, cylindrical case with a pair of 10-foot leads extending from one end. The shunt should be connected as close as possible to the rails, but no farther away than the existing leads will permit.

To afford maximum protection from physical damage, the shunt should be encased in a protective enclosure or buried. Although it is not necessary to bury the shunt below the frost line, it should be buried (either vertically or horizontally) at least 18 inches below the surface (see paragraph 12.3.2).

**Table 12-25:
Narrow-band Shunt, 62780-f Specifications**

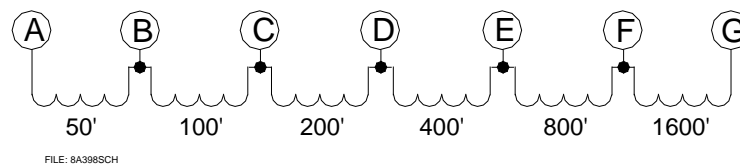
PARAMETER	VALUES
Dimensions	
Height	14.125 inches (35.9 centimeters)
Diameter	4.125 inches (10.5 centimeters)
Weight	7 pounds (3.18 kilograms) (approximate)
Frequencies	See Table 12-24 above
Leads	10 feet (304.8 centimeters); number 6 AWG, stranded, black PVC

12.5.4 Adjustable Inductor Assembly, 8A398-6 (Used With Single- Frequency Shunts Only)



**Figure 12-35:
Adjustable Inductor Assembly, 8A398-6**

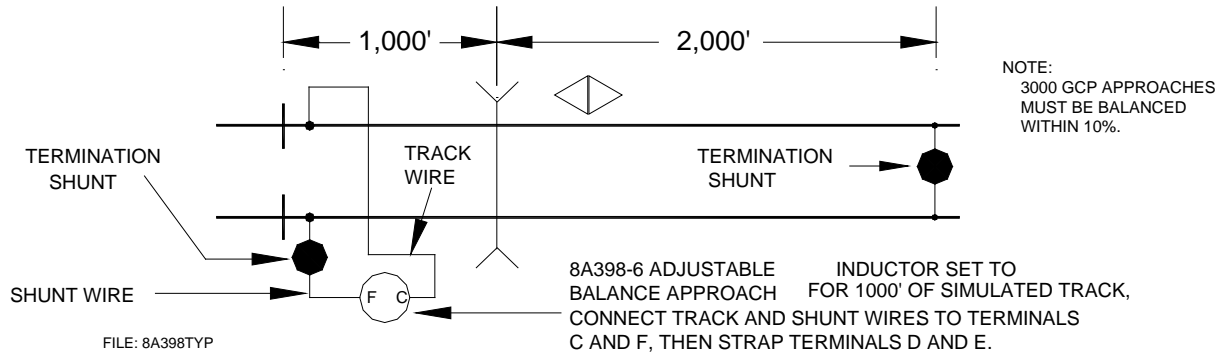
Insulated joints located in one approach frequently prevent both termination shunts from being installed at approximately equal distances from the MS/GCP feed point as required. When Safetran's single-frequency narrow-band shunts (62775-f/62780-f) are used to terminate these approaches, Adjustable Inductor Assembly, 8A398-6 (Table 12-30), may be used along with the shunt in the shorter approach to compensate for the reduced distance (see diagram).



**Figure 12-36:
Adjustable Inductor, 8A398-6 Schematic**

The inductor assembly consists of a 3-inch diameter ABS plastic enclosure with mounting brackets at the base. Extending from the top of the assembly are seven AAR terminals that accommodate connections to six inductors which are wired in series and housed within the sealed unit.

Referring to Table 12-26 (following page), locate the desired simulated track length (column 1), then read across the table to determine which inductors (indicated by terminal pairs in column 2) are required to simulate that length.



**Figure 12-37:
Adjustable Inductor Used with Termination Shunt**

Next, connect the track wire and the shunt wire (see example above) to the two terminals indicated in column 2. Finally, install a strap between the terminal pairs indicated in column 3 to short any inductors located between the track and shunt wire connecting terminals (see 8A398 schematic diagram at the top of next page) which are not required for the desired length. For example, if the required simulated track length is 1,000 feet, the track and shunt wires are connected to terminals C and F. A strap is then installed between terminals D and E to short the 400-foot inductor and remove it from the series circuit. Track lengths are selectable in 50-foot increments ranging from 50 to 3,150 feet.

**Table 12-26:
Adjustable Inductor Assembly Terminal Connections**

COL. 1	COL. 2	COL. 3	COL. 1	COL. 2	COL. 3
SIMULATED TRACK LENGTH (FEET)	CONNECT TRACK & SHUNT WIRES TO THESE TERMINALS	CONNECT SHORTING STRAPS BETWEEN THESE TERMINALS	SIMULATED TRACK LENGTH (FEET)	CONNECT TRACK & SHUNT WIRES TO THESE TERMINALS	CONNECT SHORTING STRAPS BETWEEN THESE TERMINALS
50	A-B		1650	A-G	B-C, C-D, D-E, & E-F
100	B-C		1650	A-G	B-C, C-D, D-E, & E-F
150	A-C		1700	B-G	C-D, D-E, E-F
200	C-D		1750	A-G	C-D, D-E, E-F
250	A-D	B-C	1800	C-G	D-E, E-F
300	B-D		1850	A-G	B-C, D-E, E-F
350	A-D		1900	B-G	D-E, E-F
400	D-E		1950	A-G	D-E, E-F
450	A-E	B-C, C-D	2000	D-G	E-F
500	B-E	C-D	2050	A-G	B-C, D-E, E-F
550	A-E	C-D	2100	B-G	C-D, E-F
600	C-E		2150	A-G	C-D, E-F
650	A-E	B-C	2200	C-G	E-F
700	B-E		2250	A-G	B-C, E-F
750	A-E		2300	B-G	E-F
800	E-F		2350	B-G	E-F

**Table 12-26:
Adjustable Inductor Assembly Terminal Connections**

COL. 1	COL. 2	COL. 3	COL. 1	COL. 2	COL. 3
SIMULATED TRACK LENGTH (FEET)	CONNECT TRACK & SHUNT WIRES TO THESE TERMINALS	CONNECT SHORTING STRAPS BETWEEN THESE TERMINALS	SIMULATED TRACK LENGTH (FEET)	CONNECT TRACK & SHUNT WIRES TO THESE TERMINALS	CONNECT SHORTING STRAPS BETWEEN THESE TERMINALS
850	A-F	B-C, C-D, D-E	2400	E-G	
900	B-F	C-D, D-E	2450	A-G	B-C, C-D, D-E
950	A-F	C-D, D-E	2500	B-G	C-D, D-E
1000	C-F	D-E	2550	A-G	CD, D-E
1050	A-F	B-C, D-E	2600	C-G	D-E
1100	B-F	D-E	2650	A-G	B-C, D-E
1150	A-F	D-E	2700	B-G	D-E
1200	D-F		2750	A-G	
1250	A-F	B-C, C-D	2800	D-G	D-E
1300	B-F	C-D	2850	A-G	B-C, C-D
1350	A-F	C-D	2900	B-G	C-D
1400	C-F		2950	A-G	C-D
1450	A-F	B-C	3000	C-G	
1500	B-F		3050	A-G	B-C
1550	A-F		3100	B-G	
1600	F-G		3150	A-G	

**Table 12-27:
Simulated Track Inductor, 8V617 Specifications**

PARAMETER	VALUES
Dimensions	
Diameter	3.375 inches (8.57 centimeters)
Height	9.0 inches (22.86 centimeters)
Weight	5 pounds, 12 ounces (2.59 kilograms) (approximate)

12.5.5 Multifrequency Narrow-Band Shunt, 62775-XXXX

Multifrequency Narrow-band Shunt, 62775-XXXX, is slightly larger than its single-frequency counterpart (paragraph 12.5.1), but exhibits the same electrical characteristics as the basic single- frequency unit.



WARNING

THIS MULTIFREQUENCY SHUNT SHOULD NOT BE USED ANYWHERE WITHIN A MODEL 300 OR 400 GCP APPROACH (MULTIFREQUENCY NARROW-BAND SHUNT (62780-XXXX) IS RECOMMENDED).

The multifrequency narrow-band shunt is available in three frequency ranges for terminating all standard Safetran equipment operating frequencies. The shunt is housed in a hermetically-sealed, cylindrical case with a pair of 10-foot leads extending from one end and seven standard AAR terminals extending from the other. The terminals are labeled A through G and are jumpered to select the desired shunting frequency (see Table 12-28).

Terminal jumper hardware is supplied with each shunt and a label located inside the removable end cap identifies the terminal jumpering for each frequency. The pliable end cap covering the terminal end of the shunt is secured in place by a sturdy stainless steel clamp for protection against moisture.

**Table 12-28:
Multifrequency Narrow-band Shunt (62775-XXXX) Frequency Selection Jumpers**

SHUNT PART NO.	FREQUENCY (HZ)	JUMPER SHUNT TERMINALS
62775-1543	156	A-F, C-G, D-E, C-D, E-F
	211	A-G, C-D, C-G, D-E
	285	B-C, D-G, C-D
	348	B-C, C-D
	430	B-C
62775-3497	348	A-B, C-D, E-F, B-C, D-E, F-G
	430	A-B, C-D, E-F, B-C, D-E
	525	A-B, C-D, B-C, D-E
	645	A-B, C-D, B-C
	790	A-B, B-C
	970	A-B
62775-8621	86	A-F, D-E, D-G, E-F
	114	B-G, D-E, D-G
	156	C-D, D-G
	211	C-D



CAUTION

THE SHUNT IS SHIPPED WITH NO FACTORY JUMPERS INSTALLED AND IS, THEREFORE, ELECTRICALLY OPEN AND DOES NOT LOAD ANY FREQUENCY ON THE TRACK. INSTALL JUMPERS FOR THE DESIRED FREQUENCY BEFORE PLACING THE UNIT IN SERVICE. CAREFULLY TIGHTEN ALL NUTS ON ALL FREQUENCY JUMPERS, AND THEN INSTALL A SECOND NUT TO SECURELY LOCK THE ASSEMBLY.

The shunt should be connected as close as possible to the rails, but no farther away than the existing leads will permit. To afford maximum protection from physical damage, the shunt should be encased in a protective enclosure or buried (see paragraph 12.3.2). Although it is not necessary to bury the shunt below the frost line, it should be buried (either vertically or horizontally) at least 18 inches below the surface.

**Table 12-29:
Multifrequency Narrow-band Shunt, 62775-XXXX Specifications**

PARAMETER	VALUES
Dimensions	
Height	22.0 inches (55.9 centimeters)
Diameter	5.0 inches (12.7 centimeters)
Weight	10 pounds (4.54 kilograms) (approximate)
Frequencies	See Table 12-28 above
Leads	10 feet (304.8 centimeters); number 6 AWG, stranded, black PVC

12.5.6 Multifrequency Narrow-Band Shunt, 62780-XXXX

Multifrequency Narrow-band Shunt, 62780-XXXX, produces less loading effect on adjacent frequencies (10 Ohms reactance) than the 62775-XXXX shunts (paragraph 12.5.3) and, therefore, can be used in territories with overlapping Model 300 and 400 GCP approaches. The 62780 shunt is compatible with all Safetran motion sensors and GCPs. The 62780 narrow-band shunt is available in three multifrequency versions for terminating all 11 standard Safetran equipment operating frequencies (see Table 12-30).

The multifrequency narrow-band shunt (62780) is housed in a hermetically-sealed, cylindrical case with a pair of 10-foot leads extending from one end and seven standard AAR terminals from the opposite end of the case. The terminals are labeled A through G and are jumpered to select the desired shunting frequency. Terminal jumper hardware is supplied with each multifrequency shunt and a label located inside the removable end cap identifies the terminal jumpering for each frequency. The pliable end cap covering the terminal end of the shunt is secured in place by a sturdy stainless steel clamp for protection against moisture.



CAUTION

THE MULTIFREQUENCY NARROW-BAND SHUNT IS SHIPPED WITH NO FACTORY JUMPERS INSTALLED AND IS, THEREFORE, ELECTRICALLY OPEN AND DOES NOT LOAD ANY FREQUENCY ON THE TRACK. INSTALL JUMPERS FOR THE DESIRED FREQUENCY BEFORE PLACING THE UNIT IN SERVICE. CAREFULLY TIGHTEN ALL NUTS ON ALL FREQUENCY JUMPERS, AND THEN INSTALL A SECOND NUT TO SECURELY LOCK THE ASSEMBLY.

The shunt should be connected as close as possible to the rails, but no farther away than the existing leads will permit. To afford maximum protection from physical damage, the shunt should be encased in a protective enclosure or buried (see paragraph 12.3.2). Although it is not necessary to bury the shunt below the frost line, it should be buried (either vertically or horizontally) at least 18 inches below the surface.

**Table 12-30:
Multifrequency Narrow-band Shunt (62780-XXXX) Frequency Selection Jumpers**

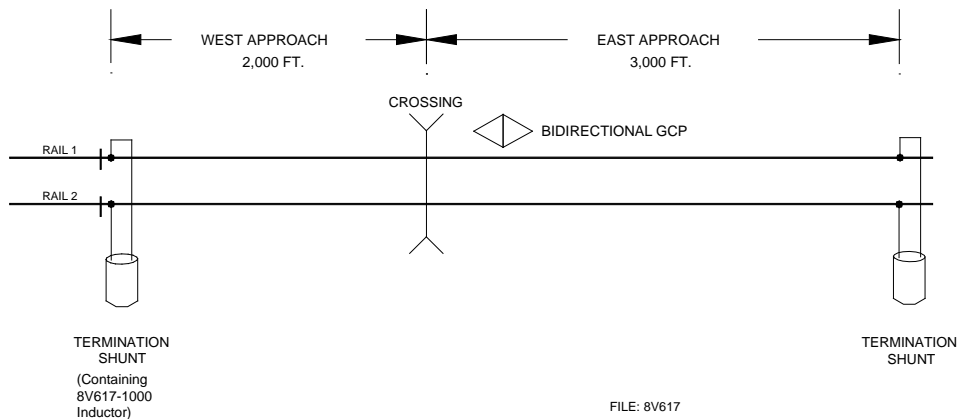
SHUNT PART NO.	FREQUENCY (HZ)	JUMPER SHUNT TERMINALS
62780-1543	156	A-F, C-G, D-E, C-D, E-F
	211	A-G, C-D, C-G, D-E
	285	B-C, D-G, C-D
	348	B-C, C-D
	430	B-C
62780-5297	525	A-B, C-D, B-C, D-E
	645	A-B, C-D, B-C
	790	A-B, B-C
	970	A-B
62780-8621	86	A-F, D-E, D-G, E-F
	114	B-G, D-E, D-G
	156	C-D, D-G
	211	C-D

**Table 12-31:
Multifrequency Narrow-band Shunt, 62780-XXXX Specifications**

PARAMETER	VALUES
Dimensions	
Height	22 inches (55.9 centimeters)
Diameter	5 inches (12.7 centimeters)
Weight	10 pounds (4.54 kilograms) (approximate)
Leads	10 feet (304.8 centimeters); number 6 AWG, stranded, black PVC

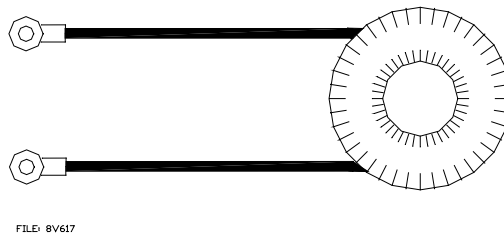
12.5.7 Simulated Track Inductor, 8V617 (Used With Multifrequency Shunts Only)

In bidirectional motion sensor and grade crossing predictor installations, insulated joints located in one approach frequently prevent both termination shunts from being installed at approximately equal distances from the MS/GCP feed point as required. When Safetran's multifrequency narrow-band shunts (62775/62780) are used to terminate the approaches, Simulated Track Inductor, 8V617 (Figure 12-39), may be used along with the shunt in the shorter approach to compensate for the reduced distance (see Figure 12-38 below).



**Figure 12-38:
Typical Simulated Track Inductor, 8V617, Application**

The inductor consists of an insulated, toroid-wound coil with a pair of 4-inch number 18 AWG stranded wire leads with 1/4-inch ring terminals attached. The inductor is supplied in 20 configurations to simulate track lengths ranging from 200 to 4,000 feet in 200-foot increments. Each inductor is identified with the basic part number followed by a dash number indicating the simulated distance (in feet) as listed in Table 12-32.



**Figure 12-39:
Simulated Track Inductor, 8V617**

**Table 12-32:
Simulated Track Inductor Part Number Listing**

BASIC PART NO.	DASH NUMBER = DISTANCE (FEET)			
8V617	-0200	-1200	-2200	-3200
	-0400	-1400	-2400	-3400
	-0600	-1600	-2600	-3600
	-0800	-1800	-2800	-3800
	-1000	-2000	-3000	-4000

NOTE

NOTE
If the chart is missing or illegible, refer to Table 12-28 (62775) or Table 12-30 (62780) in this manual.

To install the inductor in the narrow-band shunt, use the following procedure:

1. After determining the shunt frequency and compensating distance required, loosen the clamp and remove the end cap from the shunt to gain access to the frequency-selection terminals. Refer to the small chart inside the end cap for terminal strapping information.

WARNING

WARNING
BEFORE INSTALLING THE 8V617 INDUCTOR, VERIFY THAT IT IS THE CORRECT DISTANCE VALUE SPECIFIED FOR THE APPLICATION.

2. Refer to Table 12-34 and note the inductor mounting terminals for the applicable shunt and frequency. Remove the nuts, washers, and shorting link from the shunt terminals indicated. Discard the shorting link and install the inductor in its place by connecting the inductor leads to the two terminals. Install the washers and nuts and tighten securely.
3. Wrap the inductor in the foam insulation (included with inductor) as shown in Table 12-29 and carefully insert into the shunt housing between the terminals and case at the approximate location shown. Position the inductor with the leads extending horizontally toward the side (not upward) to prevent interference with the shunt end cap.
4. Return the end cap to its original position on the shunt and tighten the clamp securely.

**Table 12-33:
Simulated Track Inductor, 8V617 Specifications**

PARAMETER	VALUES
Dimensions	
Diameter	1.875 inches (4.75 centimeters)
Thickness	0.875 inches (2.23 centimeters)
Weight	5 ounces (0.69 kilograms) (approximate)

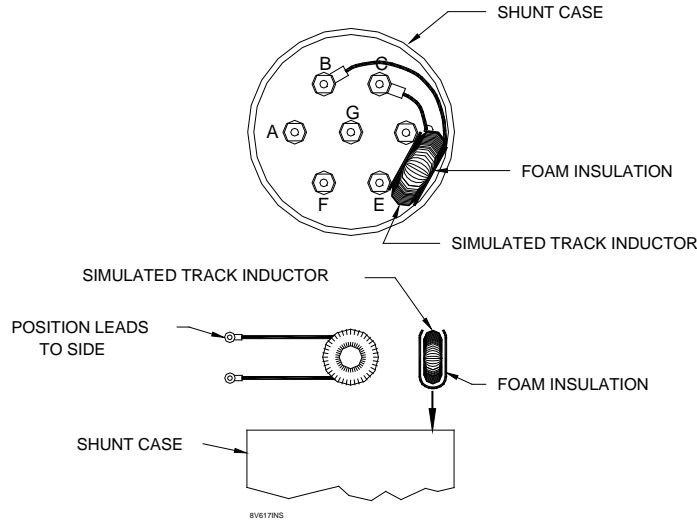


Figure 12-40:
Typical Installation of Simulated Track Inductor, 8V617, in 62775/62780 Shunt

Table 12-34:
Simulated Track Inductor, 8V617, Mounting Terminals

NARROW-BAND SHUNT PART NO.	FREQUENCY (HZ)	REMOVE SHORTING LINK AND CONNECT INDUCTOR LEADS BETWEEN SHUNT TERMINALS
62775/62780-1543	156	A And F
	211	A And G
	285	B And C
	348	B And C
	430	B And C
62775-3497	348	A And B
	430	A And B
	525	A And B
	645	A And B
	790	A And B
	970	A And B
62780-5297	525	A And B
	645	A And B
	790	A And B
	970	A And B
62775/62780-8621	86	A And F
	114	B And G
	156	C And D
	211	C And D

12.5.8 Wideband Shunt, 8A076A

Wideband Shunt, 8A076A, provides an effective short circuit to AC but presents an open circuit to DC. The shunt may be used as a termination shunt where no other frequencies (other than the GCP) are present. The shunt may be used to bypass existing insulated joints required for DC signaling purposes within the track circuit but should not be used to bypass insulated joints in DC coded track circuits or where AC or coded AC circuits exist.

The wideband shunt is housed in a sealed, cylindrical case with a pair of 10-foot leads extending from one end. The shunt should be connected as close as possible to the rails, but no farther away than the existing leads will permit. Although it is not necessary to bury the shunt below the frost line, it should be buried (either vertically or horizontally) at least 18 inches below the surface to afford maximum protection from physical damage (see paragraph 12.3.2).

**Table 12-35:
Wideband Shunt, 8A076 Specifications**

PARAMETER	VALUES
Dimensions	
Height	7.5 inches (19.1 centimeters)
Diameter	3.35 inches (8.5 centimeters)
Weight	7 pounds (3.18 kilograms) (approximate)
Leads	10 feet (304.8 centimeters); number 6 AWG, stranded, black PVC

12.6 SURGE SUPPRESSION PANELS, 80026-XX

12.6.1 Surge Panels 80026-01, -02, -22, --1, -32, -33, -34, -35, -36, -37, -38, -39, -41, -41A, & -50

The 80026 surge panel is available in a variety of configurations to meet specific customer requirements. Each panel is equipped with the appropriate combination of equalizers and arresters to provide the necessary protection for battery and/or track circuits. The -01, -02, and -22 units are designed for wall mounting while the remaining panels are designed for standard 24-inch rack mounting. For additional surge protection requirements and/or custom designed surge panels, contact Safetran Application Engineering. Refer to Table 12-36 for specific surge panel applications.

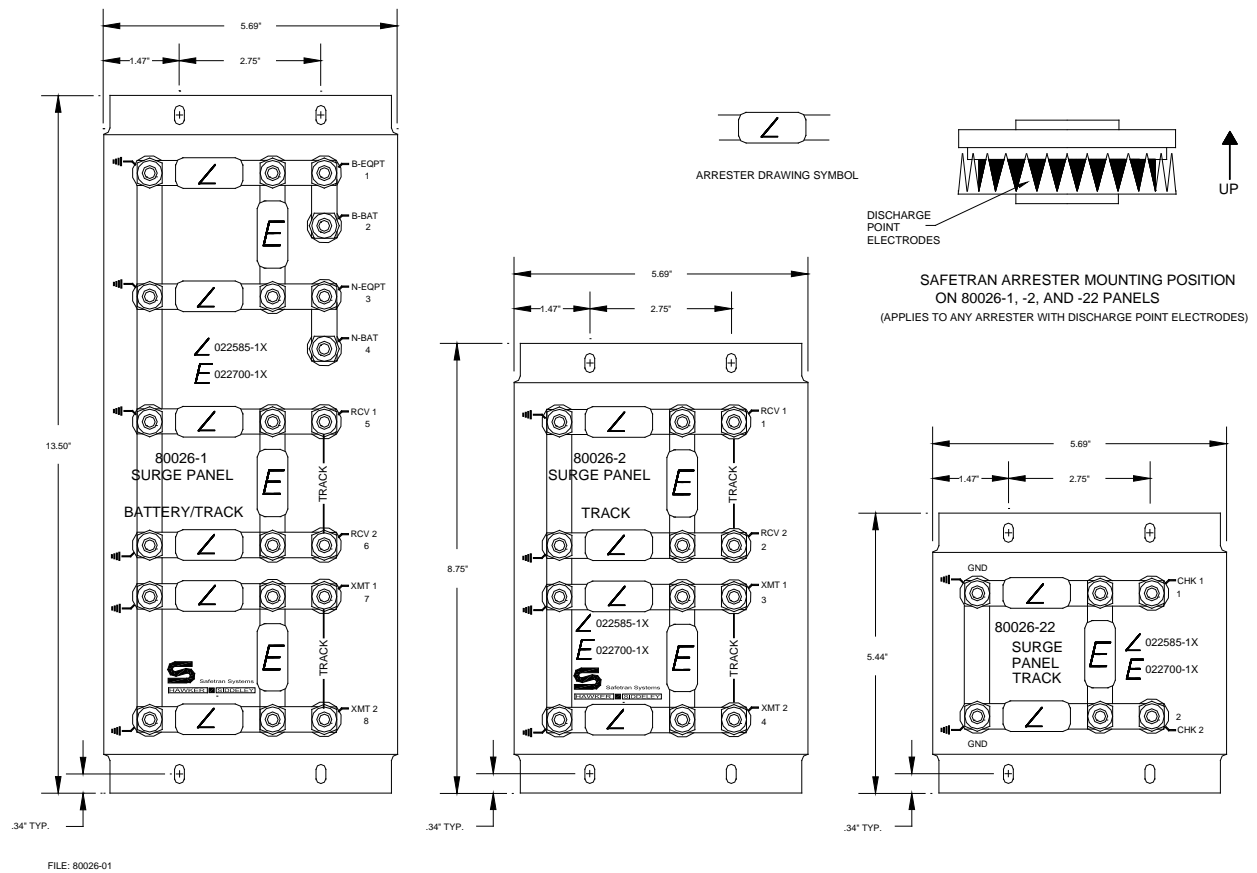
**Table 12-36:
80026-XX Surge Panel Applications**

SURGE PANEL PART NUMBER	TYPE/NUMBER OF CIRCUITS PROTECTED	MOUNTING REQUIREMENTS	NOTES
80026-01	Battery, 1 Track, 1	Wall mount only	
80026-02	Track, 1	Wall mount only	Use with -01 panel for 2 nd track
80026-22	Track, 1	Wall mount only	Use for 6-wire applications
80026-31	Battery, 1 Track, 1	Rack mount	
80026-32	Battery, 1 Track, 1	Rack mount	Use with -31 panel for 2 nd track & 2 nd battery
80026-33	Battery, 1	Rack mount	Used with -31 panel for 2 nd battery
80026-34	Track, 1	Rack mount	Used with -31 panel for 2 nd track
80026-35	Track, 2	Rack mount	
80026-36	Track, 1	Rack mount	Used with -31 panel for 2 nd track. Used with six-wire applications for transmit, receive, and check receive lead protection.
80026-37	Battery, 1	Rack mount	
80026-38	Track, 2	Rack mount	Used with -37 panel. Used in applications with six wires on one track and four on the other.
80026-39	Battery, 4 Battery Input/Output line protection for 2 DAX or 2 UAX circuits	Rack mount	Normally used with second battery when line circuit protection is required.
80026-41	110 VAC (Includes four 15-amp reset- table circuit breakers and one 15-amp GFI duplex outlet)	Rack mount	Use primarily when 20-amp solid state crossing controller (90980) is used in conjunction with 3000 GCP
80026-41A	110 VAC (Includes four 15-amp and one 25-amp reset- table circuit breakers and one 15-amp GFI duplex outlet)	Rack mount	Use primarily when 40-amp solid state crossing controller (90990) is used in conjunction with 3000 GCP
80026-50	Input/output circuits, 4	Rack mount	Generally used for UAX input or DAX output

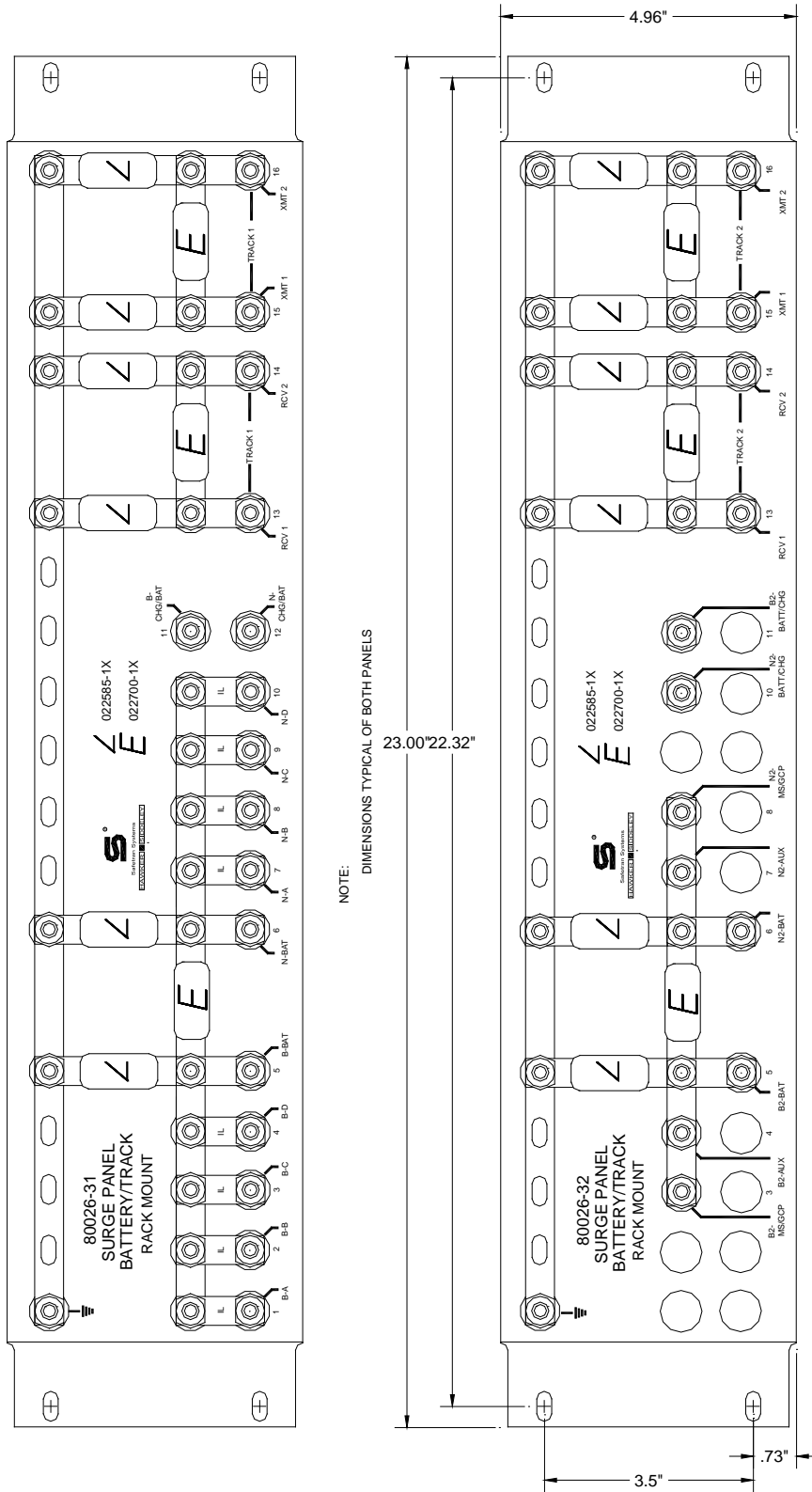
Surge panel nomenclature and mounting dimensions are provided in the figures indicated in the following chart.

**Table 12-37:
Surge Panel / Figure Number Cross Reference Chart**

SURGE PANEL	FIGURE NUMBER	SURGE PANEL	FIGURE NUMBER
80026-01	Figure 12-41	80026-36	Figure 12-44
80026-02	Figure 12-41	80026-37	Figure 12-45
80026-22	Figure 12-41	80026-38	Figure 12-45
80026-31	Figure 12-42	80026-39	Figure 12-46
80026-32	Figure 12-42	80026-41	Figure 12-46
80026-33	Figure 12-43	80026-41A	Figure 12-46
80026-34	Figure 12-43	80026-50	Figure 12-48
80026-35	Figure 12-43		



**Figure 12-41:
Surge Panels, 80026-01, -02, -22**



**Figure 12-42:
Surge Panels, 80026-31 And -32**

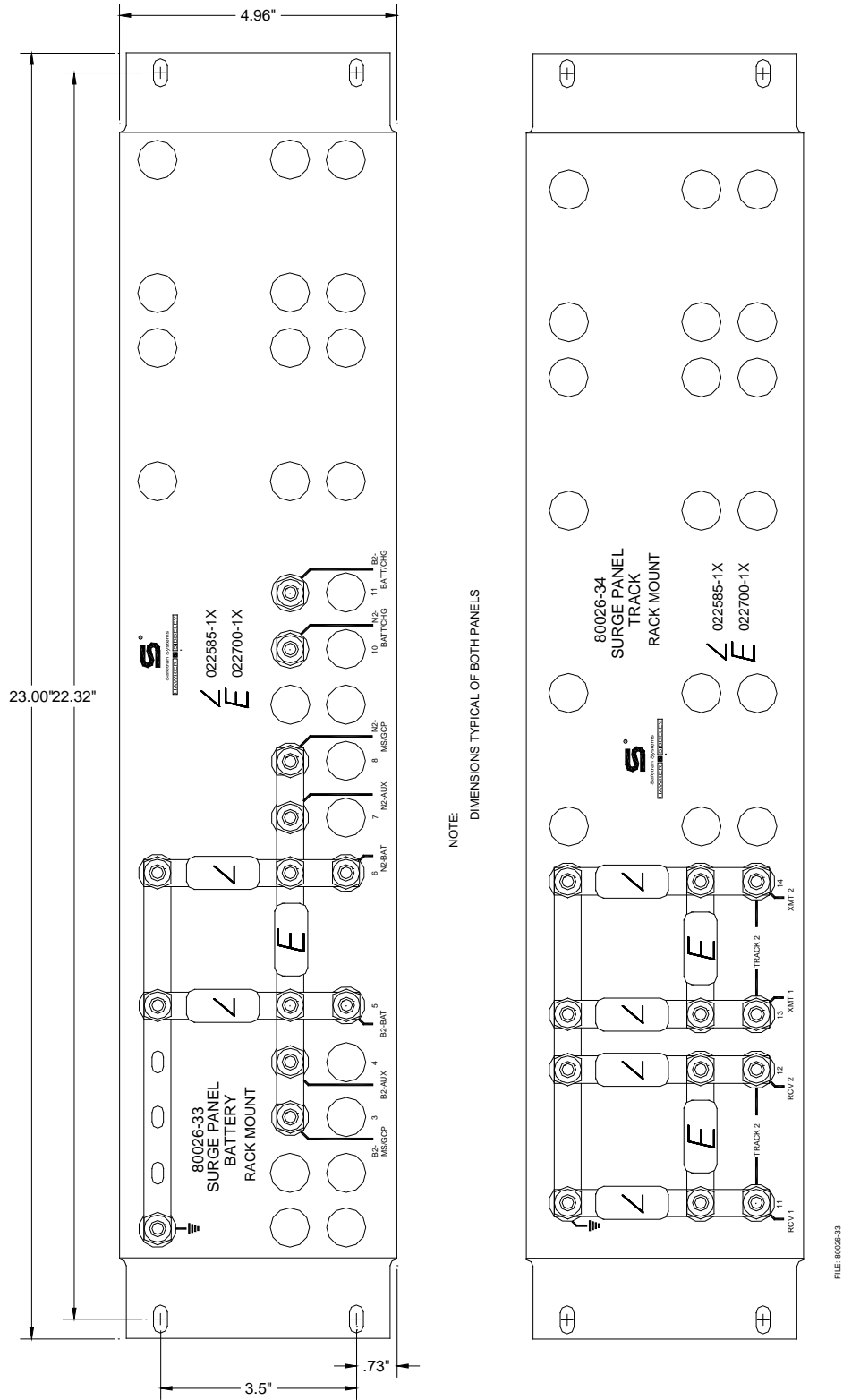


Figure 12-43:
Surge Panels, 80026-33 And -34

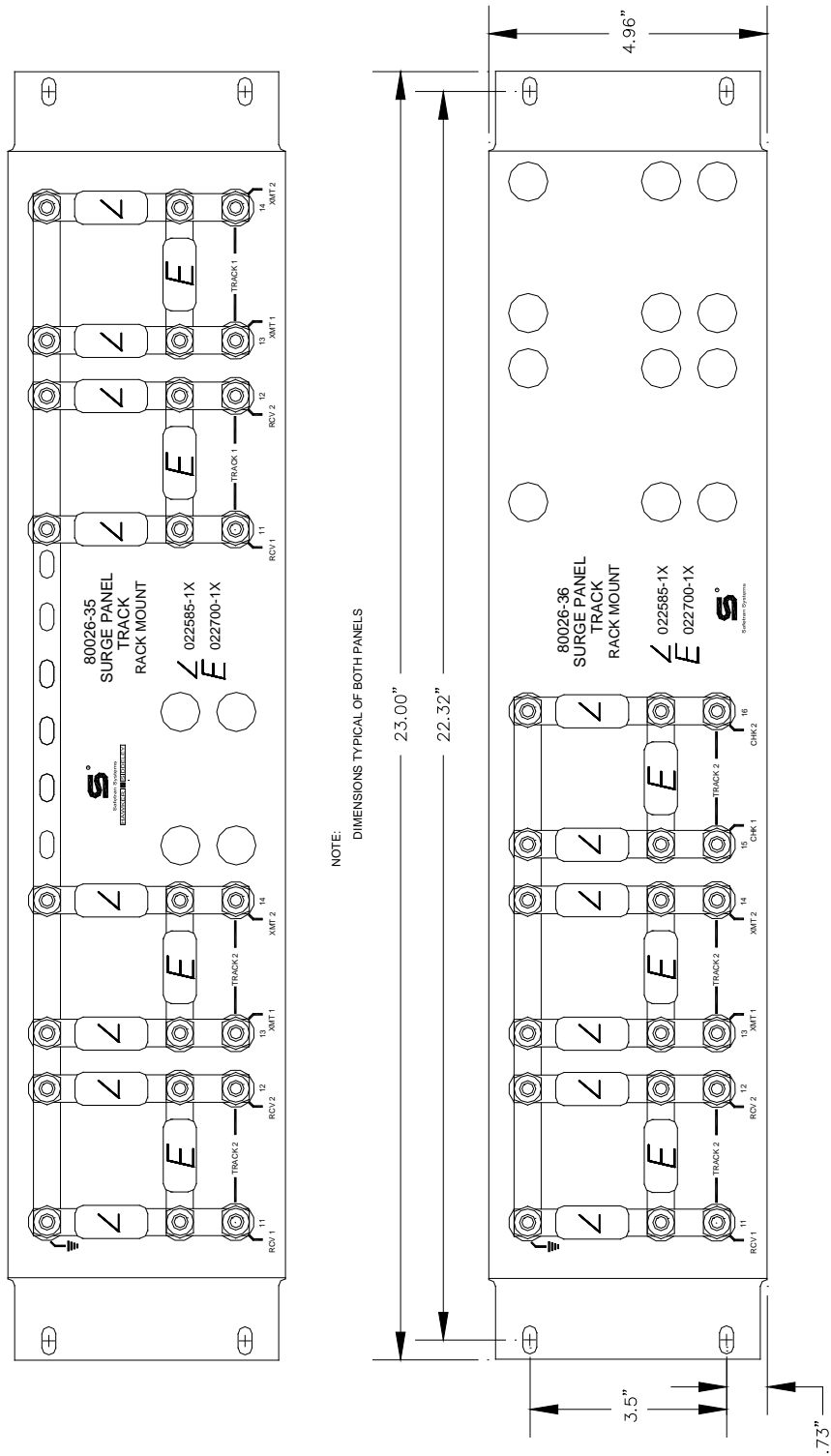


Figure 12-44:
Surge Panels, 80026-35 And -36

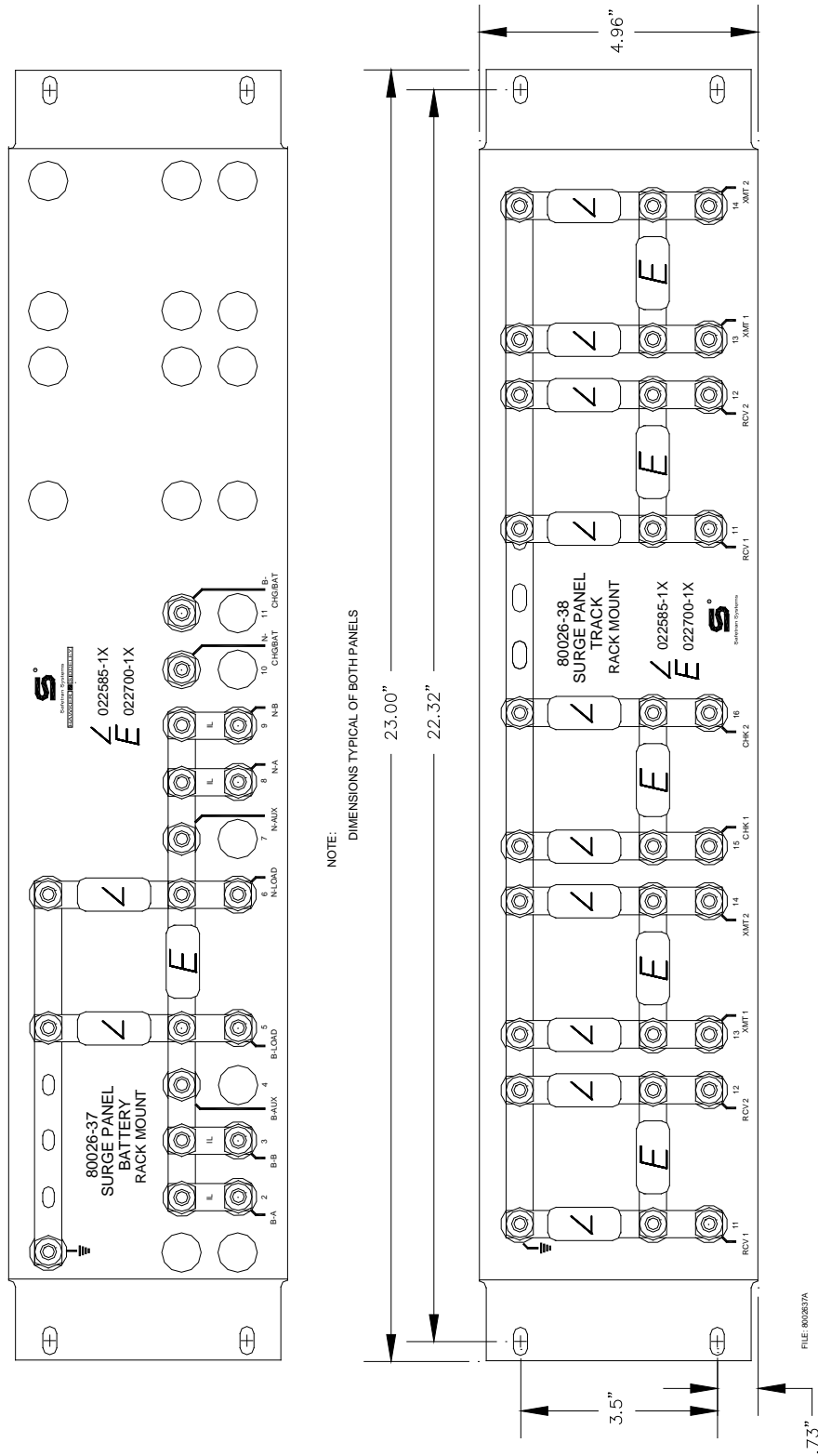


Figure 12-45:
Surge Panels, 80026-37 And -38

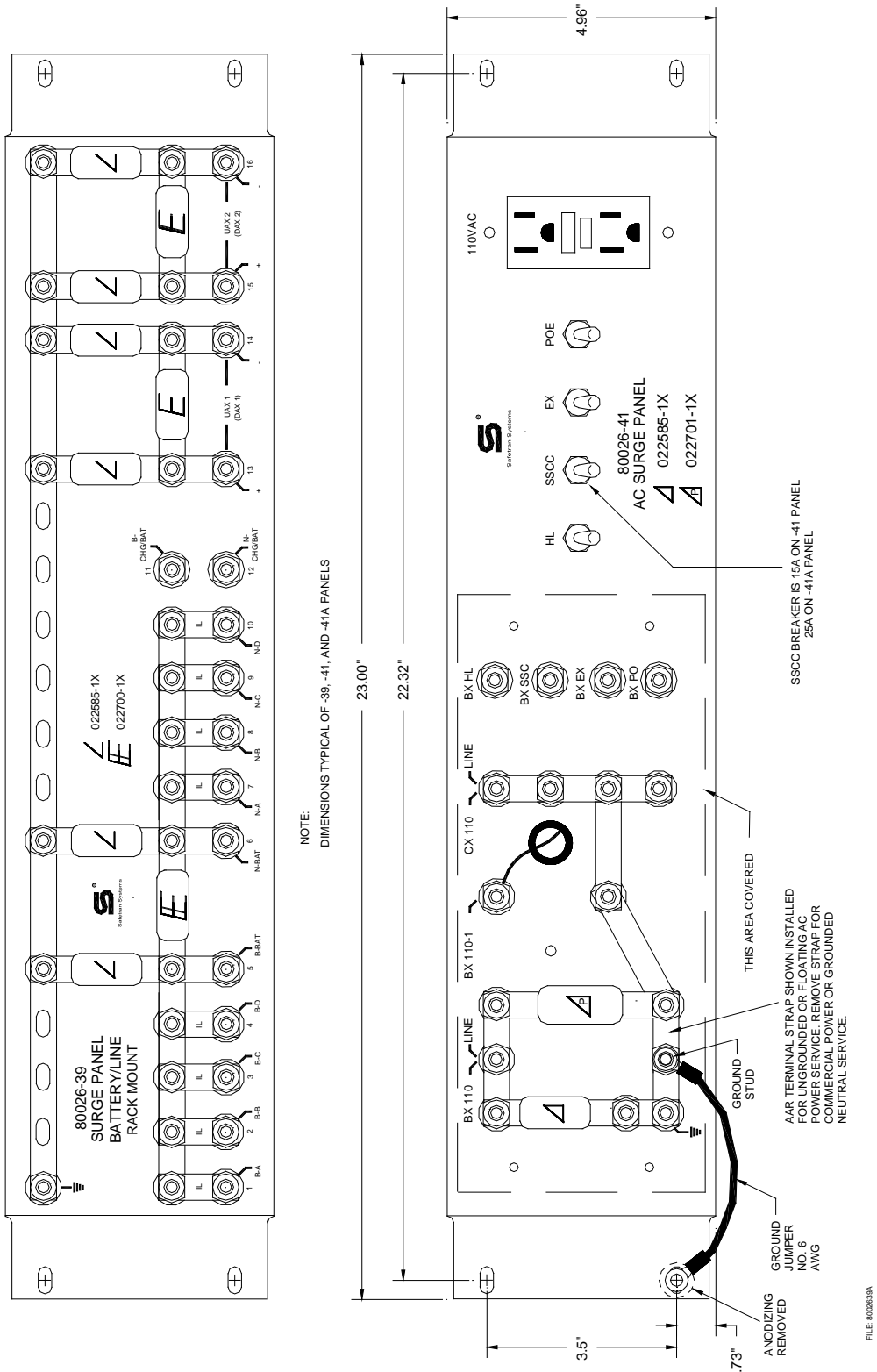


Figure 12-46:
Surge Panels, 80026-39, 41 and 41A

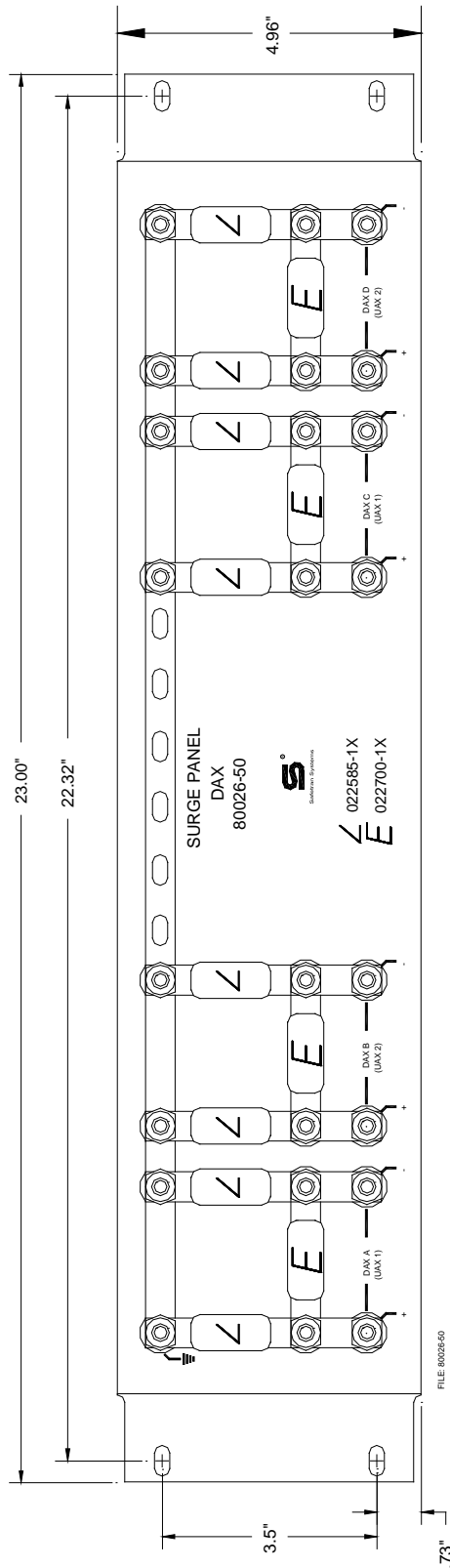


Figure 12-47:
Surge Panel, 80026-50

12.7 AUXILIARY EQUIPMENT PANELS

A number of auxiliary equipment panels are available for use with the 3000 GCP. The panels are designed for standard 24-inch rack mounting and will accommodate a variety of auxiliary equipment as described in the following paragraphs.

12.7.1 Rectifier Panel Assembly, 80033

Rectifier Panel Assembly, 80033, is equipped with equalizers and arresters to provide surge protection on the B (+) and N (-) connections to the battery and the GCP. Mounting holes are also provided for Exide Rail Battery Charger, Model ERBC 12/20M. See Figure 12-48 for mounting dimensions.

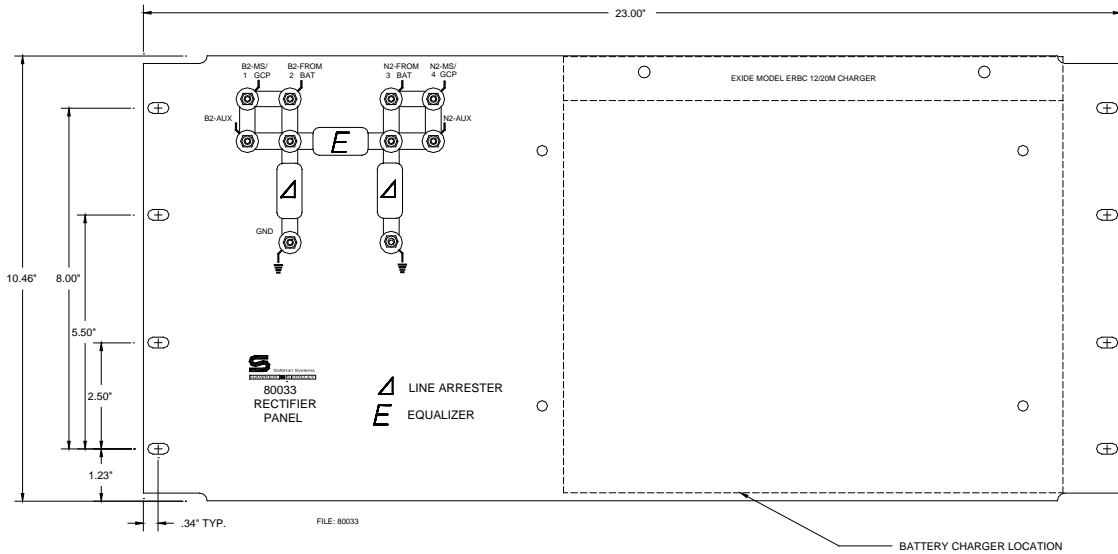


Figure 12-48:
Rectifier Panel Assembly, 80033

12.7.2 Cable Termination Panel Assembly, 91042

Cable Termination Panel Assembly, 91042, is a universal mounting panel which can be ordered with from 1 to 19 pairs of strapped AAR terminals. See Figure 12-49 for mounting dimensions.

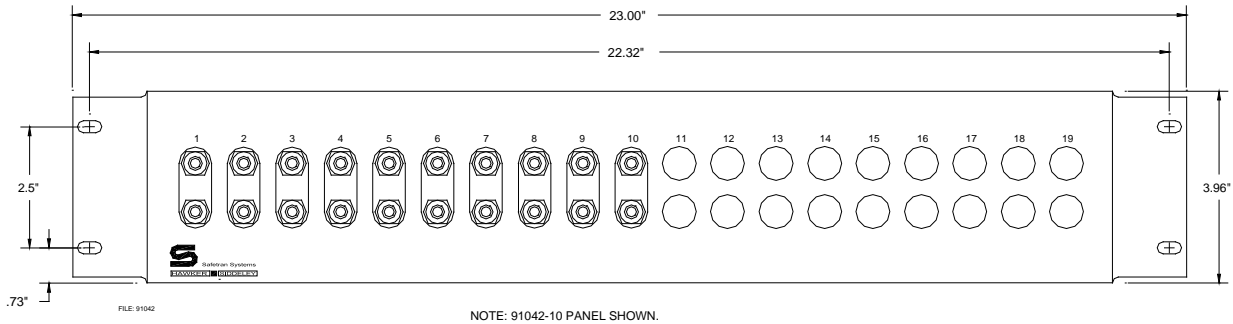


Figure 12-49:
Cable Termination Panel Assembly, 91042

12.7.3 Data Recorder Interface & Vital AND-Gate Driver Panel Assembly, 91043

Data Recorder Interface and Vital AND-Gate Driver Panel Assembly, 91043, provides mounting holes to accommodate a single vital AND-gate driver (90975), two 80025 16-channel data recorder interface assemblies (80025), or two 24-channel data recorder interface assemblies (80035). See Figure 12-50 for mounting dimensions.

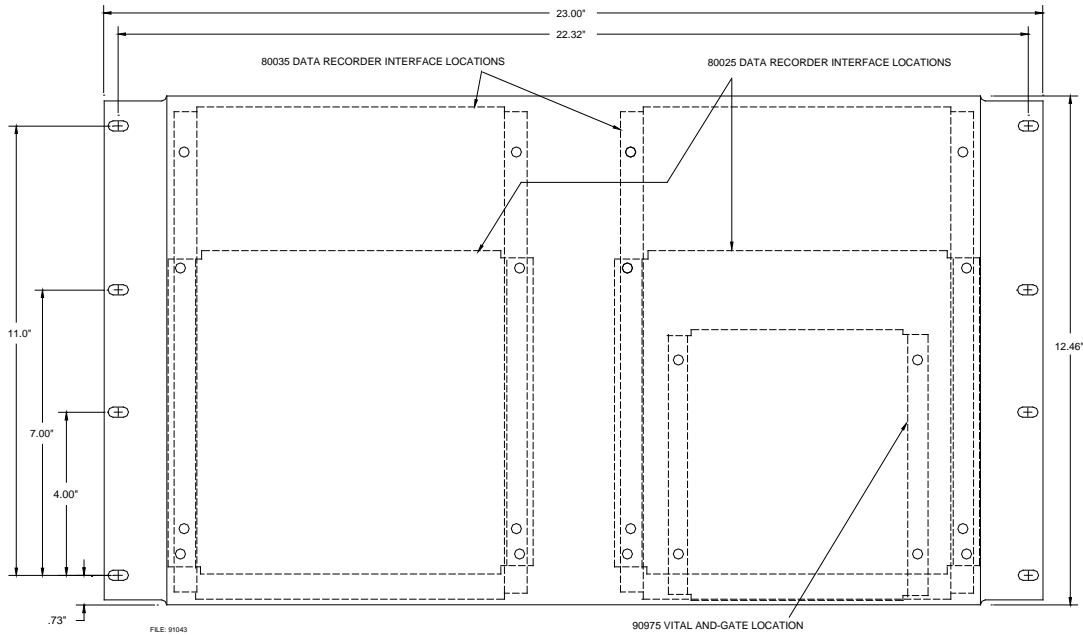


Figure 12-50:
Data Recorder Interface And Vital AND-Gate Driver Panel Assembly, 91043

12.7.4 Vital AND-Gate Driver Panel Assembly, 91044

Vital AND-Gate Driver Panel Assembly, 91044, provides mounting holes to accommodate from one to three vital AND-gate driver assemblies (90975). See Figure 12-51 for mounting dimensions.

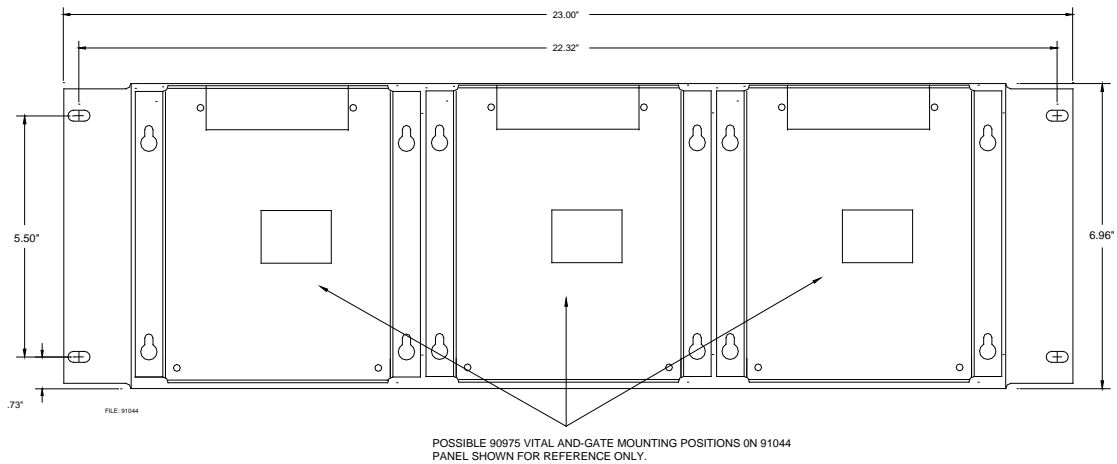


Figure 12-51:
Vital AND-Gate Driver Panel Assembly, 91044

SECTION 13 3000 GCP SYSTEM PROGRAMMING PARAMETERS

13.1 GENERAL

This section provides step-by-step application programming instructions for the 3000 GCP System.

- Included at the end of this section (Section 13.4) are condensed programming procedures which are provided as a reference for system users who are familiar with the general programming procedure but require occasional prompting during programming.
- The procedures contained in this section apply to initial programming as well as reprogramming of the 3000 GCP.
- Follow the steps in the order listed and perform all steps necessary for the specific application.
- See Section 4 of SIG-00-00-02, Model 3000 GCP Instruction and Installation Manual for descriptions of the programming menu items.



WARNING

WARNING

THE 3000 GCP MUST BE PROGRAMMED CORRECTLY FOR THE LOCATION AND APPLICATION. FAILURE TO DO SO MAY RESULT IN SHORT OR NO WARNING TIME!

WHEN INSTALLING, TESTING OR PERFORMING MAINTENANCE ON OR NEAR A 3000 SYSTEM, ENSURE ADEQUATE SAFETY PRECAUTIONS ARE TAKEN FOR PERSONNEL, VEHICULAR AND TRAIN TRAFFIC.

When power is initially applied to the system, displays similar to the following appear in sequence:

**MODEL 3000
MICRO GCP**

plus one of the following:

**SOFTWARE VERSION
8V980-AO1F**

(Units equipped with
80014 Processor module)

**SOFTWARE VERSION
9V065-B01D**

(Units equipped with
80044 Processor Module)

**SOFTWARE VERSION
9V121-A02J**

(Units equipped with
80214 Processor Module)

NOTE

The software version indicates the revision level.

**COPYRIGHT 2007
SAFTETTRAN
SYSTEMS**

SYSTEM TEST
.....

When the system status message indicated below is displayed, the system is ready for programming (EZ and EX values shown are example values only; actual values may vary).

STATUS T1
EZ: 100 EX: 87

NOTE

NOTE

If the 3000 GCP is equipped with an 80044 or 80214 processor module, and the enhanced track-shunting detection (ED) operating mode (paragraph 4.17.9) is enabled, *ED* appears in the upper right corner of the system status display (see example below) when poor shunting conditions are detected. The *ED* indication remains on the display for the duration of the train move (until the train leaves the track circuit).

STATUS T1	*ED*
EZ: 65	EX: 89

The 3000 GCP provides two application-programming modes:

- Program Mode – This is the primary programming mode for system application parameters.
- Function Mode – This extended programming mode is provided for programming additional parameters.

Each of these modes is menu driven.

- This simplifies operator interface when programming the system according to specific application requirements.

NOTE

NOTE

Application information to be programmed into the Program and Function menus should first be entered on the 3000 GCP Application History Card (see SIG-00-00-02, Model 3000 GCP Instruction and Installation Manual, Figures 4-27 through Figure 4-29). The History Card can then be used as a reference during programming. The order in which the information is listed on the card corresponds to the order in which the information is requested in the Program and Function menus.

The Program and Function menus are selected by pressing the corresponding key on the 3000 GCP keyboard/display assembly.

- When a menu is selected, each item in that menu can be viewed by using the down arrow key (▼) to scroll through the menu.
- The menu is continuous in that it starts over at the beginning when the end of the menu is reached.
- During programming, enter the information requested and then press the down arrow key (▼) to proceed to the next menu item.
- The up arrow key (▲) can be used to scroll through the menu in reverse order.

If, while programming, a keyboard entry is not made within 90 seconds of the last keyboard entry, the system automatically reverts to the Status Mode (see Section 4 of SIG-00-00-02, Model 3000 GCP Instruction and Installation Manual, paragraph 4.2) and the initial Status Mode display appears.

- If this occurs, reselect the programming mode by pressing the appropriate key (**PROGRAM** or **FUNCTION**), scroll to the menu item where the programming interruption occurred, and proceed as before.

NOTE

NOTE

If the message **ENTER PASSWORD** appears on the display while reprogramming an operational system, enter the proper four-digit password and press the **ENTER** key to continue.

Each menu contains a number of system application parameters that require specific inputs for each track controlled by the system. This specific input requirement is identified by the following designations appearing in the application parameter display:

- **T1** (for track 1)
- **T2** (for track 2)

Systems programmed for a single track (**T1** displayed) will accept data inputs for track 1 only. For two-track systems proceed as follows:

- Step 1. Enter the track 1 data when **T1** appears on the display.
- Step 2. Press the **TRACK 2** key to select the **T2** display.
T1 in the display changes to **T2**
- Step 3. Enter the track 2 data.
- Step 4. Press the **TRACK 1** key

The display is returned to track 1 with **T1** replacing **T2** in the display.

NOTE

NOTE

Pressing the **TRACK 2** key when the system is programmed for one track causes the following message to appear on the display for 2 seconds.

**ONLY ONE TRACK
IS SELECTED**

If incorrect digits are entered while making numerical data entries during programming, but the **ENTER** key has not yet been pressed, press the **CLEAR** key to return to the original value displayed. The correct digits may then be entered.

13.2 MAKING PROGRAM CHANGES

Program changes can be made on in-service 3000 GCP's at any time, providing no train is present in the approach. To make a program change:

- Select the appropriate programming menu (Program or Function)
- Scroll to the menu item to be changed and enter the new parameter value
- Record the new value in the proper location on the 3000 GCP Application History Card.

WARNING

WARNING

THE 3000 GCP MUST BE PROGRAMMED CORRECTLY FOR THE LOCATION AND APPLICATION. FAILURE TO DO SO MAY RESULT IN SHORT OR NO WARNING TIME.

Instructions for changing each menu item in the Program and Function menus are provided in paragraph 13.3. Table 13-1 lists each menu item in the Program and Function menus and the corresponding programming step(s) in paragraph 13.3 required to change each item.

**Table 13-1:
Programming Step Index**

PARAMETER	REFERENCE STEP NO.	PARAMETER	REFERENCE STEP NO.
Set to Default	1	Time	24
Number of Tracks	2	Daylight Savings	25
Transceiver Frequency	3	Switch to MS EZ Level	26
Unidirectional/Bidirectional	4	Transfer Delay MS to GCP	27
Transceiver Transmit Level	5	Transfer Delay MS to GCP DAX	28
Predictor/Motion Sensor	6	Prime Prediction Offset	29
Warning Time	7	Transfer MS to GCP Prime	30
Approach Distance	8	Pickup Delay Prime	31
UAX1 Pickup Delay	9	Pickup Delay DAX	32
ENA/UAX2	10	Compensation Value	33
Island Distance	11	Enhanced Detection T1/T2	34
Number of DAX's	12	Back-to-Back T1 And T2	35
DAX Track Assignment	13	Station Stop Timer T1/T2	36
DAX Approach Distance	14	Number of Track Wires	37
DAX Warning Time	15	Low EX Adjustment	38
Slaving Status	16	Low EZ Detection	39
Password (Enable)	17	Low EZ Detection Timer	40
Password (Change)	17.7	Positive Start EZ Level	41
Password (Disable)	17.15	Positive Start Timeout	42
Data Recorder Option	18	Set AT Operation Out	43
RS-232-C Baud Rate	19	Diagnostics Messages	44
RS-232-C-Data Bits	20	DAX Messages	45
RS-232-C Stop Bits	21	Advance Preempt Timer	46
RS-232-C Parity	22	Motion Sensing Level	47
Date	23		

**Table 13-2:
Programming Changes Requiring System Recalibration**

PROGRAM CHANGE	SETUP FOR CALIBRATION	SETUP FOR APPROACH LENGTH*	SETUP FOR LINEARIZATION*
Increased Number of Tracks From 1 to 2	Required For Track 2 Only	Required For Track 2 Only	Required For Track 2 Only
GCP Frequency	Required For Both Tracks	Required For Both Tracks	Required For Both Tracks
Unidirectional to Bidirectional or Bidirectional to Unidirectional	Required For Changed Track Only	Required For Changed Track Only	Required For Changed Track Only
Transmit Level Changed From Medium to Maximum or Maximum to Medium	Required For Changed Track Only	Not Required	Not Required
Approach Length	Required For Changed Track Only	Required For Changed Track Only	Required For Changed Track Only
Ballast Compensation Value	Required For Changed Track Only	Not Required	Not Required

* Setup For Approach Length and Setup For Linearization are combined into a single calibration procedure. See Section 6 of SIG-00-00-02, Model 3000 GCP Instruction and Installation Manual, paragraph 6.5.3.



WARNING

IF ANY OF THE PROGRAM CHANGES LISTED IN TABLE 13-2 ARE PERFORMED, SYSTEM RECALIBRATION IS REQUIRED (SEE SECTION 6 OF SIG-00-00-02, MODEL 3000 GCP INSTRUCTION AND INSTALLATION MANUAL).

13.3 SYSTEM PROGRAMMING

**SET TO DEFAULT
REQUIRED**

If any of the conditions listed below apply, relay drive is inhibited and the following message is flashed on the display every 2 seconds.

- Initial installation
- Processor module is replaced with another containing a different software level.
- Program PROM's on the 80014 or 80044 Processor Module are replaced with PROM's containing a different software level.
- Program in flash memory on the 80214 Processor Module is changed to a different software level.
- Control interface assembly (80020 or 80029) is replaced (includes attached printed circuit board (80017 or 80153)).

The system must be programmed to Set To Default parameters to initialize the database before proceeding with application programming.

- When the Set To Default parameters have been reset, the system must be completely reprogrammed.
- To initialize the database, proceed with programming step number 1.
- However, if none of the conditions listed above apply, skip step number 1 and proceed to step number 2 to begin application programming.

13.3.1 SET TO DEFAULT

Step 1 Press the **FUNCTION** key. The following message is displayed:

**T1 SWITCH TO MS
EZ LEVEL: 10**

Step 1.1 Press the up arrow key (▲) once. The following message is displayed:

SET TO DEFAULT

Step 1.2 Press the **NEW DATA** key. The following message is displayed:

**SET TO DEFAULT
PRESS ENTER**

Step 1.3 Press the **ENTER** key. The system must now be completely programmed starting with step 2. The following message may appear intermittently, indicating the system requires calibration (refer to Section 6 of see SIG-00-00-02, Model 3000 GCP Instruction and Installation Manual.):

**SETUP T1 AND T2
REQUIRED**

The following message is displayed when installation of default parameters is complete.

**SET TO DEFAULT
COMPLETE**

NOTE

NOTE

The word **COMPLETE** momentarily appears in the above display after 2 seconds.

13.3.2 APPLICATION PROGRAMMING

NOTE

NOTE

The value/parameter messages displayed in the following steps indicate the system default settings. If the current data displayed is correct, do not press the **NEW DATA** key but simply press the down arrow key (▼) to advance to the next step.

Step 2 Press the **PROGRAM** key. The following message is displayed:

**PROGRAM NUMBER
OF TRACKS: 2**

Step 2.1 Press the **NEW DATA** key.

Step 2.2 Enter the number of tracks (1 or 2) which are monitored by the system.

Step 2.3 Press the **ENTER** key.

Step 3 Press the down arrow key (▼) once. One of the following messages is displayed, depending on the processor module installed:

**PROGRAM
FREQUENCY:
790**

**PROGRAM T1
FREQUENCY:
790**

Step 3.1 Press the **NEW DATA** key.

Step 3.2 Enter the frequency of the transceiver module (45 to 999 Hz).

Step 3.3 Press the **ENTER** key.

Step 3.4 If the system is equipped with an 80014 or 80044 processor, proceed to step 4.

Step 3.5 If the system is equipped with an 80214 processor, press the **TRACK 2** key and repeat steps 3.1, 3.2, and 3.3 for track 2.

NOTE

NOTE
Generally used to highlight certain information relating to the topic under discussion.

Step 3.6 Press the **TRACK 1** key.

Step 4 Press the down arrow key (▼) once. The following message is displayed:

**PROGRAM T1
UNIDIRECTIONAL**

Step 4.1 Press the **NEW DATA** key. The system application for the track indicated toggles between unidirectional and bidirectional each time the **NEW DATA** key is pressed.

Step 4.2 Press the **ENTER** key when the desired application is displayed.

Step 4.3 If the system was programmed for one track in step 2.2, proceed to step 5.

Step 4.4 If the system was programmed for two tracks in step 2.2, press the **TRACK 2** key and repeat steps 4.1 and 4.2 for track 2.

Step 4.5 Press the **TRACK 1** key.

Step 5 Press the down arrow key (▼) once. The following message is displayed:

**PROGRAM T1 XMIT
LEVEL: MEDIUM**

Step 5.1 Press the **NEW DATA** key. The transceiver-transmit level for the track indicated toggles between **MEDIUM** and **MAXIMUM** each time the **NEW DATA** key is pressed.

- Step 5.2 Press the **ENTER** key when the desired transmit level is displayed.
- Step 5.3 If the system was programmed for one track in step 2.2, proceed to step 6.
- Step 5.4 If the system was programmed for two tracks in step 2.2, press the **TRACK 2** key and repeat steps 5.1 and 5.2 for track 2.
- Step 5.5 Press the **TRACK 1** key.
- Step 6 Press the down arrow key (▼) once. The following message is displayed:

**PROGRAM T1
PREDICTOR**

- Step 6.1 Press the **NEW DATA** key. The mode of operation for the track indicated toggles between **PREDICTOR** and **MOTION SENSOR** each time the **NEW DATA** key is pressed.
- Step 6.2 Press the **ENTER** key when the desired mode of operation is displayed.
- Step 6.3 If the system was programmed for one track in step 2.2, proceed to step 7
- Step 6.4 If the system was programmed for two tracks in step 2.2, press the **TRACK 2** key and repeat steps 6.1 and 6.2 for track 2.
- Step 6.5 Press the **TRACK 1** key.
- Step 7 Press the down arrow key (▼) once. The following message is displayed:

**PROGRAM T1
WARNING TIME: 35**

- Step 7.1 Press the **NEW DATA** key.
- Step 7.2 Enter the warning time for the track indicated (**25 to 99**).
- Step 7.3 Press the **ENTER** key.
- Step 7.4 If the system was programmed for one track in step 2.2, proceed to step 8
- Step 7.5 If the system was programmed for two tracks in step 2.2, press the **TRACK 2** key and repeat steps 7.1, 7.2, and 7.3 for track 2.
- Step 7.6 Press the **TRACK 1** key.
- Step 8 Press the down arrow key (▼) once. The following message is displayed:

**PROGRAM T1
APPROACH:
3000**

NOTE

NOTE

The approach distance display shown above alternates with the following display:

**PROGRAM T1
COMPUTED:
3240**

The value indicated is the approach distance computed by the system during calibration (Section 6, SIG-00-00-02, Model 3000 GCP Instruction and Installation Manual).

- Step 8.1 Press the **NEW DATA** key.
- Step 8.2 Enter the approach distance for the track indicated (**0000** to **9999**) (value is in feet).
- Step 8.3 Press the **ENTER** key.
- Step 8.4 If the system was programmed for one track in step 2.2, proceed to step 9.
- Step 8.5 If the system was programmed for two tracks in step 2.2, press the **TRACK 2** key and repeat steps 8.1, 8.2, and 8.3 for track 2.
- Step 8.6 Press the **TRACK 1** key.
- Step 9 Press the down arrow key (▼) once. The following message is displayed:

**PROGRAM UAX
PICKUP DELAY: 25**

- Step 9.1 Press the **NEW DATA** key.
- Step 9.2 Enter the pickup delay time (**0 (OFF)** to **500** seconds) for UAX 1.

WARNING

WARNING

WHEN THE UAX FEATURE IS OFF (0 IS ENTERED), THE FRONT PANEL UAX TERMINALS HAVE NO CONTROL OVER PRIME RELAY DRIVE.

- Step 9.3 Press the **ENTER** key.
- Step 10 Press the down arrow key (▼) once. The following message is displayed:

**PROGRAM ENA/UAX2
PICKUP DELAY: 25**

- Step 10.1 Press the **NEW DATA** key.
- Step 10.2 Enter the pickup delay time (**0 (ENA)** to **500** seconds) for UAX 2.

NOTE

NOTE

When UAX2 is programmed to zero (0) seconds, the terminal functions as ENA with no pickup delay and is typically used for cascading multiple GCP outputs.

Step 10.3 Press the **ENTER** key.

Step 11 Press the down arrow key (▼) once. The following message is displayed:

PROGRAM T1 ISLAND:	0
-------------------------------	----------

Step 11.1 Press the **NEW DATA** key.

Step 11.2 Enter the island distance for the track indicated (**0** to **999** feet).

Step 11.3 Press the **ENTER** key.

Step 11.4 If the system was programmed for one track in step 2.2, proceed to step 12.

Step 11.5 If the system was programmed for two tracks in step 2.2, press the **TRACK 2** key and repeat steps 11.1, 11.2, and 11.3 for track 2.

Step 11.6 Press the **TRACK 1** key.

Step 12 Press the down arrow key (▼) once. The following message is displayed:

PROGRAM NUMBER OF DAXS:	0
--	----------

Step 12.1 Press the **NEW DATA** key.

Step 12.2 Enter the number of DAX circuits in the system (**0** to **4** possible with 80014 processor, **0** to **8** possible with 80044 and 80214 processors).

NOTE

NOTE

For 3000 GCP's equipped with an 80044 or 80214 Processor Module, numbers representing four additional DAX circuits (5 through 8) can be entered; however, these entries are reserved exclusively for 8-DAX GCP Models 3008 and 3008D2. Because GCP Models 3000, 3000D2, and 3000D2L can only accommodate a maximum of two DAX modules (four DAX circuits), the parameters for DAX circuits identified as E(5), F(6), G(7), and H(8) will be displayed on these units (if the number of DAX circuits entered is greater than 4), but will be ignored by the system.

Step 12.3 Press the **ENTER** key.

Step 12.4 If **0** (zero) is entered in step 12.2, proceed to step 16.

Step 12.5 If a number from **1** to **8** is entered, proceed to step 13.

Step 13 Press the down arrow key (▼) once. The following message is displayed:

PROGRAM	DAX A
TRACK:	1

Step 13.1 Press the **NEW DATA** key.

Step 13.2 Enter the track assignment for the DAX indicated (1 for T1 or 2 for T2). The default DAX for track 1 is A, C, E, & G. The default DAX for track 2 is B, D, G, & H.

Step 13.3 Press the **ENTER** key.

Step 14 Press the down arrow key (▼) once. One of the following message is displayed, depending on the processor module installed.

PROGRAM	DAX
A	
DISTANCE:	0

PROGRAM	DAX
A	
DISTANCE:	PREEMPT

Step 14.1 Press the **NEW DATA** key.

Step 14.2 Enter the offset distance for the DAX indicated (**0 (PREEMPT)** to **9999** feet).

Step 14.3 Press the **ENTER** key.

Step 15 Press the down arrow key (▼) once. One of the following message is displayed, depending on the processor module installed:

PROGRAM	DAX
A	
WARNING TIME:	35

PROGRAM	DAX
A	
WARNING TIME:	45

Step 15.1 Press the **NEW DATA** key.

Step 15.2 Enter the warning time for the DAX indicated (**25** to **99** seconds).

Step 15.3 Press the **ENTER** key.

Step 15.4 If two or more DAX circuits were selected in step 12.2, repeat steps 13 through 15.3 for each additional DAX.

Step 16 Press the down arrow key (▼) once. The following message is displayed:

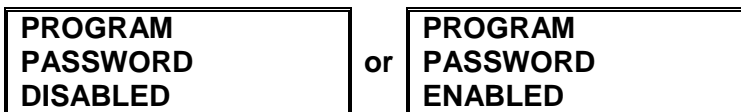
PROGRAM
SLAVING
MASTER

Step 16.1 Press the **NEW DATA** key. The display toggles between **MASTER** and **SLAVE** each time the **NEW DATA** key is pressed

Step 16.2 Select the slaving status for the 3000 GCP case (**MASTER** or **SLAVE**).

Step 16.3 Press the **ENTER** key.

Step 17 Press the down arrow key (▼) once. One of the following messages will be displayed, depending on the current status of the password feature:



- To leave the password feature in its current status, proceed to step 18.
- To enable the password feature, proceed to step 17.1.
- To change the current password code, proceed to step 17.7.
- To disable the password feature, proceed to step 17.15.

13.3.3 ENABLE PASSWORD

Step 17.1 Press the **NEW DATA** key. The following message is displayed:



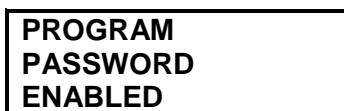
Step 17.2 Enter the new four-digit password.

Step 17.3 Press the **ENTER** key. The following message is displayed:



Step 17.4 Re-enter the new password.

Step 17.5 Press the **ENTER** key. The following message is displayed, indicating that the password feature is enabled and the password is installed:



Step 17.6 Proceed to step 18.

13.3.4 CHANGE PASSWORD

Step 17.7 Press the **NEW DATA** key. The following message is displayed:



Step 17.8 Enter existing four-digit password.

Step 17.9 Press the **ENTER** key. The following message is displayed:

**ENTER NEW
PASSWORD:**

Step 17.10 Enter new four-digit password.

Step 17.11 Press the **ENTER** key. The following message is displayed:

**CONFIRM NEW
PASSWORD:**

Step 17.12 Re-enter the new password.

Step 17.13 Press the **ENTER** key. The following message is displayed, indicating that the new password is installed:

**PROGRAM
PASSWORD
ENABLED**

Step 17.14 Proceed to step 18.

13.3.5 DISABLE PASSWORD

Step 17.15 Press the **NEW DATA** key. The following message is displayed:

**ENTER OLD
PASSWORD:**

Step 17.16 Enter the current four-digit password.

Step 17.17 Press the **ENTER** key. The following message is displayed:

**ENTER NEW
PASSWORD:**

Step 17.18 Press the **CLEAR** key. The following message is displayed, indicating that the password feature is disabled:

**PROGRAM
PASSWORD
DISABLED**

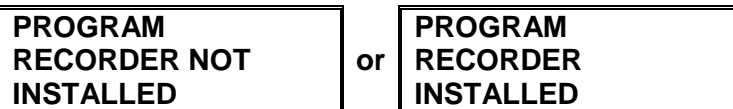
NOTE

NOTE

Steps 18 through 25.2 apply to the Data Recorder Module (80015/80115). Perform these steps as required.

13.3.6 DATA RECORDER PROGRAMMING

Step 18 Press the down arrow key (▼) once. One of the following messages is displayed, depending upon the current data recorder status:



Step 18.1 Press the **NEW DATA** key. Each time the **NEW DATA** key is pressed, the entry toggles between **NOT INSTALLED** and **INSTALLED**.

- If the data recorder option is to be used, select **INSTALLED**.
- If the data recorder option is not to be used, select **NOT INSTALLED**.

Step 18.2 Press the **ENTER** key when the applicable data recorder option is displayed.

Step 18.3 If **INSTALLED** is selected, proceed to step 19.

NOTE

NOTE

Steps 19 through 22.3 set the RS232C interface port parameters to enable the 3000 GCP to communicate with an external PC or printer, and may be performed at a future date prior to downloading recorded data to a PC or printing. An external PC or printer, may be connected to the data recorder module (80015/80115) via the 9-pin RS232C connector located on the front edge of the module. Refer to the applicable PC software or printer manufacturer's manual to determine the appropriate values to enter.

Step 18.4 If **NOT INSTALLED** is selected, proceed to step 26.

Step 19 Press the down arrow key (▼) once. The following message is displayed:



Step 19.1 Press the **NEW DATA** key.

Step 19.2 Use the up (▲) or down (▼) arrow keys to display the PC/printer baud rate (**300, 1200, 2400, 4800, or 9600**).

- The default value for units equipped with an 80014 Processor module is 300.
- The default value for units equipped with an 80044 or 80214 Processor module is 9600.

Step 19.3 Press the **ENTER** key.

Step 20 Press the down arrow key (▼) once. The following message is displayed:

PROGRAM RS-232-C DATA BITS: 8
--

Step 20.1 Press the **NEW DATA** key.

Step 20.2 Use the up (▲) or down (▼) arrow keys to display the number of data bits for the PC/printer (7 or 8).

- The default value for units equipped with an 80014 Processor module is 7.
- The default value for units equipped with an 80044 or 80214 Processor module is 8.

Step 20.3 Press the **ENTER** key.

Step 21 Press the down arrow key (▼) once. The following message is displayed:

PROGRAM RS-232-C STOP BITS: 1
--

Step 21.1 Press the **NEW DATA** key.

Step 21.2 Use the up (▲) or down (▼) arrow keys to display the number of stop bits for the PC/printer (1 or 2).

- The default value for units equipped with an 80014 Processor module is 2.
- The default value for units equipped with an 80044 or 80214 Processor module is 1.

Step 21.3 Press the **ENTER** key.

Step 22 Press the down arrow key (▼) once. The following message is displayed:

PROGRAM RS-232-C PARITY: NONE
--

Step 22.1 Press the **NEW DATA** key.

Step 22.2 Use the up (▲) or down (▼) arrow keys to display the type of parity used by the PC/printer (**NONE, ODD, EVEN, MARK, or SPACE**).

Step 22.3 Press the **ENTER** key.

Step 23 Press the down arrow key (▼) until the date display message (similar to that shown below) appears.

PROGRAM DATE FRI 07 JUL 2007
--

Step 23.1 Press the **NEW DATA** key. The cursor appears at the first digit of the day-of-the-month entry.

- Step 23.2 Enter the day of the month.
- The entry must consist of two digits (**01, 12, 27**, etc.).
 - When the second digit is entered, the cursor moves to the first letter of the month entry.
- Step 23.3 Use the up (▲) or down (▼) arrow keys to display the desired month entry.
- Step 23.4 Press the **NEW DATA** key. The cursor appears at the first digit of the year entry.
- Step 23.5 Enter all four digits for the year entry (**1999, 2000**, etc.). As the last digit is entered, the applicable day of the week is automatically displayed and the cursor moves to the first letter of the day-of-the-week entry.
- Step 23.6 Review all time entries and change any if necessary.
- Step 23.7 Press the **ENTER** key.
- Step 24 Press the down arrow key (▼) once. A time display message similar to that shown below appears.

PROGRAM	TIME
12:45:56	(24 HR)

Time is displayed in hours:minutes:seconds (hh:mm:ss) format.

- Step 24.1 Press the **NEW DATA** key. The cursor appears at the first digit of the hours entry.
- Step 24.2 Enter the hours. The entry must consist of two digits (**01, 02**. etc.).
- When the second digit is entered, the cursor moves to the first digit of the minutes entry.

NOTE

NOTE

If 24-hour (military) time format is used, be sure to enter the hours in the same format (01, 12, 18, 21, etc.).

- Step 24.3 Enter the minutes. The entry must consist of two digits (01,12, 21, etc.).
- When the second digit is entered, the cursor moves to the first digit of the seconds entry.

NOTE

NOTE

To ensure precise time setting, it may be helpful to set the minutes entry approximately two minutes ahead of the actual time to allow sufficient time to complete steps 24.4 and 24.5 below. Then, when the entered minutes time arrives, step 24.6 can be performed.

- Step 24.4 Enter the seconds. The entry must consist of two digits (01, 12, 21, etc.).
- When the second digit is entered, the cursor moves to the first character of the time format (AM, PM, 24 HR) entry.
- Step 24.5 Use the up (▲) or down (▼) arrow keys to display the desired time format entry.
- When using 24-hour (military) format, follow the time entry with 24 HR.
 - When using standard 12-hour format, follow the time entry with AM or PM, whichever is appropriate.

Step 24.6 Press the **ENTER** key at the exact second when real time coincides with the time entered on the display.

Step 24.7 Verify that the seconds portion of the display is advancing.

Step 25 Press the down arrow key (▼) once. The following daylight savings time message is displayed.

<p>PROGRAM DAYLIGHT SAVINGS: OFF</p>

NOTE

<p>NOTE Safetran Systems software does not support the changes passed by the US Congress in regards to shifting Daylight Savings Time from the traditional dates as has been the case since October/November 2007.</p>

Step 25.1 Press the **NEW DATA** key. Each time the **NEW DATA** key is pressed, the entry toggles between **OFF** and **ON**.

- If daylight savings time is to be used, select **ON** and the recorder will change the time setting automatically at the beginning (2:00 a.m. on the first Sunday in April) and end (2:00 a.m. on the last Sunday in October) of the daylight savings time period.
- If daylight savings time is not to be used, select **OFF**.

Step 25.2 Press the **ENTER** key when the applicable condition is displayed.

13.3.7 EXTENDED APPLICATION PROGRAMMING

Step 26 Press the **FUNCTION** key. The following message is displayed:

<p>T1 SWITCH TO MS EZ LEVEL: 10</p>
--

Step 26.1 Press the **NEW DATA** key.

Step 26.2 Enter the EZ level at which the indicated track circuit switches from predictor to motion sensor mode (**0 (OFF)** to **100**).

Step 26.3 Press the **ENTER** key.

Step 26.4 If a single track is selected in step 2.2, proceed to step 27.

Step 26.5 If the system is programmed for two tracks, press the **TRACK 2** key and repeat steps 26.1 through 26.3 above for track 2.

Step 26.6 Press the **TRACK 1** key.

Step 27 Press the down arrow key (▼) once. The following message is displayed:

<p>TRANSFER DELAY MS TO GCP T1: OFF</p>
--

Step 27.1 Press the **NEW DATA** key.

Step 27.2 Enter the amount of time that the indicated track circuit will remain in the motion sensor mode before reverting to the grade crossing predictor mode (**0 (OFF)** to **500** seconds).

NOTE

NOTE

The Transfer Delay and the Advance Preempt Timer functions both exercise control of the MS/GCP CONTROL terminal; therefore, only one of these functions may be used at one time.

Step 27.3 Press the **ENTER** key.

Step 27.4 If the system was programmed for one track in step 2.2, proceed to step 27.7.

Step 27.5 If the system was programmed for two tracks, press the **TRACK 2** key and repeat steps 27.1 through 27.3 for track 2.

Step 27.6 Press the **TRACK 1** key.

Step 27.7 If the system is equipped with an 80214 Processor Module having a revision level of A01E or later and a transfer delay value of 1 to 500 seconds is set in step 27.2, proceed to step 28.

Step 27.8 If the system is equipped with an 80044 processor module or an 80214 Processor Module having a revision level of A01D or earlier or the transfer delay value set in step 27.2 is 0 (OFF), proceed to step 29.

Step 28 Press the down arrow key (▼) once.

NOTE

If one or more DAX circuits are selected (step 12.2) and corresponding DAX distance values greater than zero are assigned (step 14.2), the following message displays:

**TRANSFER MS TO
GCP DAX A: OFF**

If no DAX circuits are selected (step 12.2) or no distance value is set for the assigned DAX circuit (step 14.2), the following message displays. When this occurs, proceed to step 29.1

**PRIME PREDICTION
OFFSET T1: OFF**

Step 28.1 Press the **NEW DATA** key. The display toggles between **OFF** and **ON** each time the **NEW DATA** key is pressed.

Step 28.2 Press the **ENTER** key when the desired low EZ detection entry is displayed.

Step 28.3 If two or more DAX circuits are selected (step 12.2), repeat steps 28 through 28.2 for each additional DAX circuit.

Step 28.4 If the system was programmed for two tracks (step 2.2), press the **TRACK 2** key and repeat steps 28.1 through 28.3 for track 2.

Step 28.5 Press the **TRACK 1** key.

Step 29 Press the down arrow key (▼) once. The following message displays:

**PRIME PREDICTION
OFFSET T1: OFF**

⚠ WARNING

WARNING

ENTERING AN INCORRECT DAX AND/OR PRIME PREDICTION OFFSET DISTANCE MAY RESULT IN SHORT OR NO WARNING TIME. WHEN A GCP TRACK CIRCUIT INCLUDES AN ISLAND, DO NOT USE PRIME PREDICTION OFFSET (PPO). WHEN A PPO DISTANCE (OTHER THAN 0) IS ENTERED, THE ISLAND CIRCUIT DOES NOT DE-ENERGIZE THE PRIME OUTPUT. THE WARNING SYSTEM WILL RECOVER WITH A TRAIN OCCUPYING THE ISLAND CIRCUIT AFTER THE PRIME PICKUP TIMER RUNS.

- Step 29.1 Press the **NEW DATA** key.
- Step 29.2 Enter the prime prediction offset distance for the indicated track (**0 (OFF)** to **9999** feet).
- Step 29.3 Press the **ENTER** key.
- Step 29.4 If the system was programmed for one track in step 2.2, proceed to step 29.7.
- Step 29.5 If the system was programmed for two tracks, press the **TRACK 2** key and repeat steps 29.1 through 29.3 for track 2.
- Step 29.6 Press the **TRACK 1** key.
- Step 29.7 If the system is equipped with an 80214 Processor Module having a revision level of A01E or later and the prime prediction offset distance is set to a value greater than 0, proceed to step 30.
- Step 29.8 If the prime prediction offset distance is set to **OFF**, proceed to step 32.
- Step 30 Press and release the up arrow key (▲) until the following message displays:

**TRANSFER MS TO
GCP PRIME T1: OFF**

- Step 30.1 Press the **NEW DATA** key. The display toggles between **OFF** and **ON** each time the **NEW DATA** key is pressed.
- Step 30.2 Press the **ENTER** key when the desired transfer timer function is displayed
- Step 30.3 If the system was programmed for two tracks (step 2.2), press the **TRACK 2** key and repeat steps 30.1 and 30.2 for track 2.
- Step 30.4 Press the **TRACK 1** key.
- Step 31 Press and release the down arrow key (▼) until the following message is displayed:

**PICKUP DELAY
PRIME: 15**

- Step 31.1 Press the **NEW DATA** key.

Step 31.2 Enter the length of time from the point at which motion ceases in the approach until the gates pick up (**8** to **500** seconds).

Step 31.3 Press the **ENTER** key.

Step 32 Press the down arrow key (▼) once. The following message is displayed only when the system is programmed for one or more DAX:

PICKUP DELAY DAX A: 15

Step 32.1 Press the **NEW DATA** key.

Step 32.2 Enter the length of time from the point at which motion ceases in the indicated DAX approach until the gates pick up when a train stops in the DAX approach (**0 (OFF)** to **500** seconds).

Step 32.3 Press the **ENTER** key.

Step 32.4 Repeat steps 32 through 32.3 for each additional DAX circuit in the system (B, C, and D).

Step 33 Press the down arrow key (▼) once. The following message is displayed:

COMPENSATION VALUE T1: 1300
--



<p style="text-align: center;"><u>WARNING</u></p> <p style="text-align: center;">THE DEFAULT COMPENSATION VALUE IS AUTOMATICALLY CALCULATED BY THE 3000 GCP SYSTEM. DO NOT CHANGE THIS VALUE WITHOUT PROPER INSTRUCTIONS.</p>

Step 33.1 Press the **NEW DATA** key.

Step 33.2 Enter the compensation value for the track indicated (**1000** to **2000**).

Step 33.3 Press the **ENTER** key.

Step 33.4 If the system was programmed for one track in step 2.2, proceed to step 33.7.

Step 33.5 If the system was programmed for two tracks, press the **TRACK 2** key and repeat steps 33.1, 31.2, and through 33.3 for track 2.

Step 33.6 Press the **TRACK 1** key.

Step 33.7 If the system is equipped with an 80044 or 80214 Processor module, proceed to step 34.

Step 33.8 If the system is equipped with an 80014 Processor module, proceed to step 36.

Step 34 Press the down arrow key (▼) once. The following message is displayed:

T1 ENHANCED DETECTION: OFF

WARNING

WARNING

RUST BUILD-UP ON THE RAILS MAY NOT ALLOW TRACK SHUNTING TO OCCUR EVEN THOUGH ENHANCED DETECTION IS PROGRAMMED TO ON. IF RUST WERE TO BUILD UP TO A DEGREE THAT NO TRACK SHUNTING OCCURS (EZ DOES NOT CHANGE), THE MODEL 3000 GCP WILL NOT SENSE TRAIN MOVEMENTS. DO NOT CONNECT THE DC SHUNTING ENHANCER PANEL TO THE 3000 GCP UAX (UAX1) TERMINALS IF OTHER WIRES ARE ALREADY CONNECTED TO THESE TERMINALS. IF THIS CONDITION EXISTS, CONTACT SAFETRAN ENGINEERING AT 1-800-793-7233 BEFORE PROCEEDING.

NOTE

NOTES

Intermittent poor shunting can result just about anywhere due to numerous causes but generally occurs due to infrequent track usage, lightly weighted cars, passenger and transit operation, spillage from rail cars, and rail contamination. Lack of any shunting generally occurs in dark territory where no DC or AC track circuits exist and few trains run. Track shunting in dark territory can be easily improved using methods similar to those employed in style-C track circuits. This involves the use of one insulated joint at the far end of each approach and the application of a DC voltage to the track at the crossing to improve shunting and thus allow the 3000 Enhanced Detection software to function properly. The Safetran DC Shunting Enhancer Panel, 80049, (see Section 3) provides a cost effective solution for improving shunting in dark territory:

- A nominal 6 volts DC is applied to the track at the crossing to break down the film on the rails.
- This DC voltage is isolated from the battery.
- A minimum of two insulated joints are required, one at the far end of each approach.
- The DC Shunting Enhancement Panel can also be easily incorporated in applications involving overlapping approaches from two or more crossings.
- Narrow-band termination shunts must be used. Do not use wideband or hardwire shunts for terminations.

- Step 34.1 Press the **NEW DATA** key. The ED operating mode for track 1 toggles between **ON** and **OFF** each time the **NEW DATA** key is pressed.
- Step 34.2 Press the **ENTER** key when the desired mode status is displayed.
- Step 34.3 If the system was programmed for one track in step 2.2, proceed to step 34.6.
- Step 34.4 If the system was programmed for two tracks, press the **TRACK 2** key and repeat steps 34.1 and 34.2 above for track 2.
- Step 34.5 Press the **TRACK 1** key.
- Step 34.6 If the ED operating mode is programmed to **ON**, proceed to step 35.
- Step 34.7 If the ED operating mode is programmed to **OFF**, proceed to step 37.
- Step 35 Press the down arrow key (▼) once. The following message is displayed:

<p>BACK TO BACK T1 AND T2: NO</p>

Step 35.1 Press the **NEW DATA** key. The back-to-back display toggles between **NO** and **YES** each time the **NEW DATA** key is pressed.

NOTE

Select **YES** when two unidirectional units are in the same 3000 GCP case and the associated approaches are located on opposite sides of the same pair of insulated joints.

Step 35.2 Press the **ENTER** key when the applicable condition is displayed.

Step 36 Press the down arrow key (▼) once. The following message is displayed:

<p>STATION STOP TIMER T1: 10</p>
--

WARNING

WARNING

IN SOFTWARE VERSIONS J AND EARLIER, WHEN THE STATION STOP TIMER IS PROGRAMMED TO A TIME OTHER THAN 10 SECONDS (MINIMUM VALUE), THERE MUST NOT BE ANY TRAIN MOVES APPROACHING THE CROSSING BETWEEN THE TIME A TRAIN LEAVES THE ISLAND AT THE CROSSING AND THE PROGRAMMED TIME OF THE STATION STOP TIMER ELAPSES

NOTE

NOTES

1. In software versions J and earlier, the Station Stop Timer can be programmed to run for up to a maximum of 500 seconds, but should normally be left at the default setting of 10 seconds.
2. The timer is initiated automatically after a train leaves the island circuit and operates in conjunction with the enhanced detection logic.
3. If the train makes a station stop after passing the crossing, the timer can be programmed for up to 500 seconds to prevent tail rings due to poor shunting after the train has stopped and then departs from the station.
4. This timer is active only if Enhanced Detection is programmed **ON**.

Step 36.1 Press the **NEW DATA** key.

Step 36.2 Enter the required Station Stop Timer value on the alphanumeric keypad (**10 to 500**).

NOTE

NOTE

1. This entry is used when a passenger station platform is located within the 3000 GCP approach.
2. The value entered on the keypad establishes the time interval (in seconds) that the internal loss-of-shunt timer is inhibited.

Step 36.3 Press the **ENTER** key when the desired time interval is displayed.

Step 36.4 If the system was programmed for one track in step 2.2, proceed to step 37.

Step 36.5 If the system was programmed for two tracks, press the **TRACK 2** key and repeat steps 36.1, 34.2, and through 36.3 for track 2.

- Step 36.6 Press the **TRACK 1** key.
- Step 37 Press the down arrow key (▼) once. The following message is displayed:

**NUMBER OF TRACK
WIRES T1: 4**

- Step 37.1 Press the **NEW DATA** key.
- Step 37.2 Enter the number of track wires for the indicated track (4 or 6).
- Step 37.3 Press the **ENTER** key.
- Step 37.4 If the system was programmed for one track in step 2.2, proceed to step 37.7.
- Step 37.5 If the system was programmed for two tracks, press the **TRACK 2** key and repeat steps 37.1, 35.2, and through 37.3 for track 2.
- Step 37.6 Press the **TRACK 1** key.
- Step 37.7 If the system is equipped with an 80044 or 80214 Processor Module, proceed to step 38.
- Step 37.8 If the system is equipped with an 80014 processor module, proceed to step 44.
- Step 38 Press the down arrow key (▼) once. The following message is displayed:

**T1 LOW EX
ADJUSTMENT:
0**

- Step 38.1 If Low EX Adjustment is required for track 1, proceed to step 38.2; otherwise, proceed to step 38.6.
- Step 38.2 Press the **NEW DATA** key.

⚠ WARNING

WARNING

DO NOT ARBITRARILY REDUCE THE EX OPERATING THRESHOLD. IMPROPER ADJUSTMENT MAY CAUSE SHORT OR NO WARNING TIME.

NOTE

NOTES

1. The EX operating threshold has been reduced to 39 in the 80044 and 80214 processors and should be low enough for most applications.
2. Before reducing the threshold, thoroughly test the ballast at the location to determine whether conditions permit the threshold reduction (see Section 7 of SIG-00-00-02, Model 3000 GCP Instruction and Installation Manual, paragraph 7.7.3.2 for the Low EX Test Procedure).

- Step 38.3 Enter the low EX threshold adjustment value for the indicated track (**0 to 5**).
- Step 38.4 Press the **ENTER** key.
- Step 38.5 If the system was programmed for one track in step 2.2, proceed to step 38.8.

Step 38.6 If the system was programmed for two tracks, press the **TRACK 2** key and repeat steps 38.2, 36.3, and through 38.4 for track 2.

Step 38.7 Press the **TRACK 1** key.

Step 38.8 If the system is equipped with an 80214 Processor Module having a revision level of 9V121– A01C or later, proceed to step 39.

Step 38.9 If the system is equipped with an 80044 processor module or an 80214 Processor Module having a revision level of 9V121– A01B or earlier, proceed to step 44.

Step 39 Press the down arrow key (▼) once. The following message is displayed:

LOW EZ DETECTION	
EZ=70	T1:OFF

Step 39.1 Press the **NEW DATA** key. The entry toggles between **ON** and **OFF** each time the **NEW DATA** key is pressed.

NOTE

NOTES

1. When programmed ON this function detects a significant reduction of EZ.
2. Low EZ detection occurs when EZ is constantly less than 70 for a period of time exceeding the Low EZ Detection Timer value (see Section 4 of SIG-00-00-02, Model 3000 GCP Instruction and Installation Manual, paragraph 4.17.4).

Step 39.2 Press the **ENTER** key when the desired low EZ detection entry is displayed.

Step 39.3 If the system was programmed for one track in step 2.2, proceed to step 39.6.

Step 39.4 If the system was programmed for two tracks, press the **TRACK 2** key and repeat steps 39.1 and 39.2 for track 2.

Step 39.5 Press the **TRACK 1** key.

Step 39.6 If low EZ detection is programmed to **ON**, proceed to step 40.

Step 39.7 If low EZ detection is programmed to **OFF**, proceed to step 41.

Step 40 Press the down arrow key (▼) once. The following message is displayed:

LOW EZ DETECTION	
TIMER:	10

Step 40.1 Press the **NEW DATA** key.

Step 40.2 Enter the value for low EZ detection timer (**02** to **99** minutes).

NOTE

NOTE

When programmed, the positive start function enables the immediate activation of the crossing warning device whenever the track circuit EZ level drops below the programmed positive start EZ value.

Step 40.3 Press the **ENTER** key.

- Step 40.4 If the system was programmed for one track in step 2.2, proceed to step 41.
- Step 40.5 If the system was programmed for two tracks, press the **TRACK 2** key and repeat steps 40.1 through 40.3 for track 2.
- Step 40.6 Press the **TRACK 1** key.
- Step 41 Press the down arrow key (▼) once. The following message is displayed:

**POSITIVE START
EZ LEVEL T1:
OFF**

- Step 41.1 Press the **NEW DATA** key.

NOTE

NOTE

When programmed, the positive start function enables the activation of the crossing warning device when ever the track circuit EZ level drops below the programmed positive start EZ value.

- Step 41.2 Enter the positive start EZ level value (**00 (OFF)** to **99**).
- Step 41.3 Press the **ENTER** key.
- Step 41.4 If the system was programmed for one track in step 2.2, proceed to step 41.7.
- Step 41.5 If the system was programmed for two tracks, press the **TRACK 2** key and repeat steps 41.1 through 41.3 for track 2.
- Step 41.6 Press the **TRACK 1** key.
- Step 41.7 If the positive start EZ level value is set to **00 (NONE)**, proceed to step 43.
- Step 41.8 If the positive start EZ level value is set to a value between **01** and **99**, proceed to step 42.
- Step 42 Press the down arrow key (▼) once. The following message is displayed:

NOTE

This display appears only when the Positive Start EZ Level option is enabled.

**POSITIVE START
TIMEOUT T1: NONE**

- Step 42.1 Press the **NEW DATA** key.
- Step 42.2 Enter the positive start timeout value (**NONE (0)** to **99** minutes).

NOTE

NOTE

The programmed value determines when Continuous Positive Start timeout will occur.

- Step 42.3 Press the **ENTER** key.
- Step 42.4 If the system was programmed for one track in step 2.2, proceed to step 43.

Step 42.5 If the system was programmed for two tracks, press the **TRACK 2** key and repeat steps 42.1 through 42.3 for track 2.

Step 42.6 Press the **TRACK 1** key.

Step 43 Press the down arrow key (▼) once. The following message is displayed:

**SET AT OPERATION
OUT: NORMAL**

Step 43.1 Press the **NEW DATA** key. The entry toggles between **NORMAL** and **DIAGNOSTICS** each time the **NEW DATA** key is pressed.

NOTE

NOTE

This function allows the automatic transfer (AT) output to be utilized either as a drive for an external Automatic Transfer unit or as an error indication signal. To select normal External Automatic Transfer unit operation, select **NORMAL**. To select the AT error indication function, select **DIAGNOSTICS**.

Step 43.2 Press the **ENTER** key when the desired automatic transfer function is displayed.

Step 43.3 If a Data Recorder module or a SEA/R node is installed, proceed to step 44.

Step 43.4 If no data recorder is installed, proceed to step 46.

Step 44 Press the down arrow key (▼) once. The following message is displayed:

**DIAGNOSTIC
MESSAGES:
ON**

NOTE

NOTE

This display appears only when a Data Recorder module is installed or when a SEA/R Node has been programmed into the GCP from a SEA/R.

Step 44.1 Press the **NEW DATA** key. The entry toggles between **ON** and **OFF** each time the **NEW DATA** key is pressed.

NOTE

NOTE

When programmed ON and this function allows a large number of new GCP diagnostic messages to be sent to either the Data Recorder module or the SEA/R recorder by the 80214 software.

Step 44.2 Press the **ENTER** key when the desired entry is displayed.

Step 44.3 If Diagnostic Messages are programmed to **ON**, proceed to step 45.

Step 44.4 If Diagnostic Messages are programmed to **OFF**, proceed to step 46.

Step 45 Press the down arrow key (▼) once. The following message is displayed:

<p>DAX MESSAGES: OFF</p>

Step 45.1 Press the **NEW DATA** key. The entry toggles between **ON** and **OFF** each time the **NEW DATA** key is pressed.

Step 45.2 Press the **ENTER** key when the desired entry is displayed.

Step 46 Press the down arrow key (▼) once. The following message is displayed:

<p>ADVANCE PREEMPT TIMER: OFF</p>
--

Step 46.1 Press the **NEW DATA** key.

Step 46.2 Enter the advance preempt timer value (**0 (OFF) TO 99**).

NOTE

The value programmed sets the time interval between the start of traffic signal preemption and the start of the crossing signals.

Step 46.3 Press the **ENTER** key when the desired entry is displayed.

Step 47 Press the down arrow key (▼) once. The following message is displayed:

<p>MOTION SENSING LEVEL T1: NORMAL</p>

NOTE

This function is normally used in conjunction with Transfer Delay timer operation.

Step 47.1 Press the **NEW DATA** key.

Step 47.2 Enter the motion sensing level value (**NORMAL (0) to 100**).

NOTE

<p>NOTES</p> <ol style="list-style-type: none"> 1. The motion sensing level function enables control of motion sensitivity. 2. An entry of 0 (ZERO) produces a NORMAL indication on the display and establishes motion sensitivity of approximately 30 mph at end of a 3000-foot approach. 3. An entry of 100 produces maximum motion sensitivity of approximately 1 mph at the feed points and 2 mph within the approach(es).
--

Step 47.3 Press the **ENTER** key.

Step 47.4 If a single track was selected in step 2.2, proceed to step 48.

Step 47.5 If the system is programmed for two tracks, press the **TRACK 2** key and repeat steps 47.1 through 47.3 for track 2.

Step 47.6 Press the **TRACK 1** key.

Step 48 Press the down arrow key (▼) once. The following message is displayed:

SET TO DEFAULT

NOTE

The routine performed by step 47 was performed in step 1, or it was not required.

This completes system application programming.

13.4 CONDENSED PROGRAMMING PROCEDURES

The condensed programming procedures are provided in Table 13-3 through Table 13-9 as a reference for system users who are familiar with the general programming procedure but require occasional prompting during system programming.

The step numbers listed in the condensed procedures correspond with the step numbers in paragraph 13.3.

**Table 13-3:
Set to Default**

STEP NO.	KEY PRESSED	DATA ENTRY KEY SEQUENCE	COMMENTS	MESSAGE DISPLAYED
1	FUNCTION			T1 SWITCH TO MS EZ LEVEL: 10
1.1	<input type="checkbox"/>			SET TO DEFAULT
1.2	NEW DATA			SET TO DEFAULT PRESS ENTER
1.3	ENTER		Setup message may intermittently appear; this indicates that Calibration (page 52) is required.	SETUP T1 AND T2 REQUIRED
			SET TO DEFAULT message displays when installation of default parameters is complete. After a delay of 2 seconds, the word COMPLETE momentarily appears in the display. The system must now be completely reprogrammed starting with step 2.	SET TO DEFAULT COMPLETE

**Table 13-4:
Application Programming Procedures**

STEP NO.	KEY PRESSED	DATA ENTRY KEY SEQUENCE	COMMENTS	MESSAGE DISPLAYED
2	PROGRAM		Default value is 2.	PROGRAM NUMBER OF TRACKS: 2
2.1	NEW DATA			
2.2		1 or 2	Enter number of tracks monitored	
2.3	ENTER			PROGRAM FREQUENCY: 790 or PROGRAM T1 FREQUENCY: 790 Display is determined by Processor module installed
3	<input type="checkbox"/>		Default value is 790 Hz.	
3.1	NEW DATA			
3.2		45 to 999	Enter frequency of transceiver module.	
3.3	ENTER			
3.4			If system is equipped with 80014 or 80044 Processors, proceed to step 4.	
3.5	TRACK 2		If system is equipped with 80214 Processor, press TRACK 2 key and repeat steps 3.1 thru 3.3 for track 2.	
3.6	TRACK 1			

NOTE

NOTE
If the 80214 is installed in a single frequency case, the frequency for track 2 must be the same as track 1, otherwise a **Track 2 Frequency Error** will occur

STEP NO.	KEY PRESSED	DATA ENTRY KEY SEQUENCE	COMMENTS	MESSAGE DISPLAYED
4	<input type="checkbox"/>		Default is UNIDIRECTIONAL.	PROGRAM T1 UNIDIRECTIONAL or PROGRAM T1 BIDIRECTIONAL
4.1	NEW DATA		System application toggles between UNIDIRECTIONAL and BIDIRECTIONAL each time NEW DATA key is pressed.	
4.2	ENTER		Press ENTER key when desired application is displayed.	

**Table 13-4:
Application Programming Procedures (Continued)**

STEP NO.	KEY PRESSED	DATA ENTRY KEY SEQUENCE	COMMENTS	MESSAGE DISPLAYED
4.3			If system was programmed for one track in step 2.2, proceed to step 5.	
4.4	TRACK 2		If system was programmed for two tracks in step 2.2, press TRACK 2 key and repeat step 4.1 and 4.2 for track 2.	
4.5	TRACK 1			
5	▼		Default is MEDIUM .	
5.1	NEW DATA		Transceiver transmit level toggles between MEDIUM and MAXIMUM each time NEW DATA key is pressed.	PROGRAM T1 XMIT LEVEL: MEDIUM or PROGRAM T1 XMIT LEVEL: MAXIMUM
5.2	ENTER		Press ENTER key when desired transmit level is displayed.	
5.3			If system was programmed for one track in step 2.2, proceed to step 6.	
5.4	TRACK 2		If system was programmed for two tracks in step 2.2, press TRACK 2 key and repeat step 5.1 and 5.2 for track 2.	
5.5	TRACK 1			
6	▼		Default is PREDICTOR .	PROGRAM T1 PREDICTOR
6.1	NEW DATA		Display toggles between PREDICTOR and MOTION SENSOR each time NEW DATA key is pressed.	
6.2	ENTER		Press ENTER key when desired mode of operation is displayed.	
6.3			If system was programmed for one track in step 2.2, proceed to step 7.	
6.4	TRACK 2		If system was programmed for two tracks in step 2.2, press TRACK 2 key and repeat steps 6.1 & 6.2 for track 2.	
6.5	TRACK 1			
7	▼		Default is 35 seconds.	PROGRAM T1 WARNING TIME: 35
7.1	NEW DATA			
7.2		25 to 99	Enter track-warning time in seconds.	
7.3	ENTER			
7.4			If system was programmed for one track in step 2.2, proceed to step 8	
7.5	TRACK 2		If system was programmed for two tracks in step 2.2, press TRACK 2 key and repeat steps 7.1 thru 7.3 for track 2.	
8	▼		Default is 3000 feet.	PROGRAM T1 APPROACH: 3000 The approach distance display alternates with the computed display:
8.1	NEW DATA			
8.2		0000 to 9999	Enter approach distance in feet.	
8.3	ENTER			
8.4			If system was programmed for one track in step 2.2, proceed to step 9.	
8.5	TRACK 2		If system was programmed for two tracks in step 2.2, press TRACK 2 key and repeat steps 8.1, 8.2, and 8.3 for track 2.	PROGRAM T1 COMPUTED: 3240
9	▼		Default is 25 seconds.	PROGRAM UAX1 PICKUP DELAY: 25
9.1	NEW DATA			
9.2		0 (OFF) to 500	Enter pickup delay time in seconds for UAX 1.	
9.3	ENTER			



WARNING

WARNING

WHEN THE UAX FEATURE IS OFF (0 IS ENTERED), THE FRONT PANEL UAX TERMINALS HAVE NO CONTROL OVER PRIME RELAY DRIVE.

**Table 13-4:
Application Programming Procedures (Continued)**

STEP NO.	KEY PRESSED	DATA ENTRY KEY SEQUENCE	COMMENTS	MESSAGE DISPLAYED
10	▼		Default is 25 seconds.	PROGRAM ENA/UAX2 PICKUP DELAY: 25
10.1	NEW DATA			
10.2		0 (ENA) to 500	Enter pickup delay time for UAX 2 in seconds.	

NOTE

NOTE
When UAX2 is programmed to zero (0) seconds, the terminal functions as ENA with no pickup delay and is typically used for cascading multiple GCP outputs.

**Table 13-4:
Application Programming Procedures (Continued)**

STEP NO.	KEY PRESSED	DATA ENTRY KEY SEQUENCE	COMMENTS	MESSAGE DISPLAYED
10.3	ENTER			
11	▼		Default is 0 feet.	PROGRAM T1 ISLAND: 0
11.1	NEW DATA			
11.2		0 to 999	Enter island distance in feet.	
11.3	ENTER			
11.4			If system was programmed for one track in step 2.2, proceed to step 12.	
11.5	TRACK 2		If system was programmed for two tracks in step 2.2, press TRACK 2 key and repeat steps 11.1 thru 11.3 for track 2.	
11.6	TRACK 1			
12	▼		Default is 0 .	PROGRAM NUMBER OF DAXS: 0
12.1	NEW DATA			
12.2		0 to 8	Enter number of DAX's in system.	
12.3	ENTER			
12.4			If 0 (zero) is entered in step 12.2, proceed to step 16.	
12.5			If a number from 1 to 8 is entered in step 12.2, proceed to step 13.	

NOTE

NOTE
For 3000 GCP's equipped with an 80044 or 80214 Processor Module, numbers representing four additional DAX circuits (5 through 8) can be entered; however, these entries are reserved exclusively for 8-DAX GCP Models 3008 and 3008D2. Because GCP Models 3000, 3000D2, and 3000D2L can only accommodate a maximum of two DAX modules (four DAX circuits), the parameters for DAX circuits identified as E(5), F(6), G(7), and H(8) will be displayed on these units (if the number of DAX circuits entered is greater than 4), but will be ignored by the system.

**Table 13-4:
Application Programming Procedures (Concluded)**

STEP NO.	KEY PRESSED	DATA ENTRY KEY SEQUENCE	COMMENTS	MESSAGE DISPLAYED
13	▼		Default for track 1 is A, C, E, & G Default for track 2 is B, D, F, & H	PROGRAM DAX A TRACK: 1
13.1	NEW DATA			
13.2		1 or 2	Enter DAX track assignment (1 for T1 or 2 for T2).	
13.3	ENTER			
14	<input type="checkbox"/>		Default is 0 (preempt).	PROGRAM DAX A DISTANCE: 0 Or PROGRAM DAX A DISTANCE: PREEMPT
14.1	NEW DATA			
14.2		0 (PREEMPT) to 9999	Enter the DAX offset distance in feet.	
14.3	ENTER			
15	▼		Default is 35 or 45 seconds depending on Processor module	PROGRAM DAX A WARNING TIME: 35 or PROGRAM DAX A WARNING TIME: 45
15.1	NEW DATA			
15.2		25 to 99	Enter the DAX warning time in seconds.	
15.3	ENTER			
15.4			If two or more DAX's are selected (step 12.2), repeat steps 13 through 15.3 for each additional DAX.	
16	<input type="checkbox"/>		Default is MASTER .	PROGRAM SLAVING MASTER
16.1	NEW DATA		The display toggles between Master and Slave each time the NEW DATA key is pressed.	
16.2		MASTER or SLAVE	Select the slaving status for the 3000 GCP case.	
16.3	ENTER			

NOTE

NOTE
Default is **DISABLED**. To leave the password feature in its current status, proceed to step 18.

**Table 13-5:
Password Programming Procedures**

STEP NO.	KEY PRESSED	DATA ENTRY KEY SEQUENCE	COMMENTS	MESSAGE DISPLAYED
17	▼		To enable the password feature (DISABLED is displayed), proceed to step 17. 1.	PROGRAM PASSWORD DISABLED or PROGRAM PASSWORD ENABLED Display determined by current password status

NOTE

NOTE
To change the current password code (**ENABLED** is displayed), proceed to step 17. 7. To disable the password feature, proceed to step 17. 15.

**Table 13-5:
Password Programming Procedures (Concluded)**

STEP NO.	KEY PRESSED	DATA ENTRY KEY SEQUENCE	COMMENTS	MESSAGE DISPLAYED
17.1	NEW DATA			ENTER NEW PASSWORD:
17.2		****	Enter new four-digit password.	
17.3	ENTER			CONFIRM NEW PASSWORD
17.4		****	Re-enter new password.	
17.5	ENTER		Password feature enabled and new password installed.	PROGRAM PASSWORD ENABLED
17.6			Proceed to step 18.	
17.7	NEW DATA			ENTER OLD PASSWORD:
17.8		****	Enter existing four-digit password.	
17.9	ENTER			ENTER NEW PASSWORD:
17.10		****	Enter new four-digit password.	
17.11	ENTER			CONFIRM NEW PASSWORD:
17.12		****	Re-enter new password.	
17.13	ENTER		New password installed.	PROGRAM PASSWORD ENABLED
17.14			Proceed to step 18.	
17.15	NEW DATA			ENTER OLD PASSWORD:
17.16		****	Enter current four-digit password.	
17.17	ENTER		Enter no number	ENTER NEW PASSWORD:
17.18	CLEAR		Password feature disabled.	PROGRAM PASSWORD DISABLED

NOTE

NOTE

Steps 18 through 25.2 apply to the Data Recorder Module (80015/80115). Perform these steps as required.

**Table 13-6:
Data Recorder Programming**

STEP NO.	KEY PRESSED	DATA ENTRY KEY SEQUENCE	COMMENTS	MESSAGE DISPLAYED
18	▼		Default is NOT INSTALLED.	PROGRAM RECORDER NOT INSTALLED or PROGRAM RECORDER INSTALLED Display determined by current recorder status
18.1	NEW DATA		Each time NEW DATA key is pressed, entry toggles between NOT INSTALLED and INSTALLED . If Data Recorder module is installed, select INSTALLED . If Data Recorder module is not installed, select NOT INSTALLED	
18.2	ENTER		Press ENTER key when applicable data recorder option is displayed.	
18.3			If INSTALLED is selected, proceed to step 19.	
18.4			If NOT INSTALLED is selected, proceed to step 26.	

NOTE

NOTE

Steps 19 through 22.3 set the RS232C interface port parameters to enable the 3000 GCP to communicate with an external PC or printer, and may be performed at a future date prior to downloading recorded data to a PC or printing. An external PC or printer, may be connected to the data recorder module (80015/80115) via the 9-pin RS232C connector located on the front edge of the module. Refer to the applicable PC software or printer manufacturer's manual to determine the appropriate values to enter.

**Table 13-7:
External PC or Printer Programming**

STEP NO.	KEY PRESSED	DATA ENTRY KEY SEQUENCE	COMMENTS	MESSAGE DISPLAYED
20	▼		Default value for units equipped with 80014 Processor module is 7. Default value for units equipped with 80044 or 80214 Processor module is 8.	PROGRAM RS-232-C DATA BITS: 8
20.1	NEW DATA			
20.2	<input type="checkbox"/> or <input type="checkbox"/>	7 or 8	Use arrow keys to display the number of data bits for the PC/printer.	
20.3	ENTER			PROGRAM RS-232-C STOP BITS: 1
21	<input type="checkbox"/>		Default value for units equipped with 80014 Processor module is 2. Default value for units equipped with 80044 or 80214 Processor module is 1.	
21.1	NEW DATA			
21.2	<input type="checkbox"/> or <input type="checkbox"/>	1 or 2	Use arrow keys to display the number of stop bits for the PC/printer.	
21.3	ENTER			
22	▼		Default is NONE.	
22.1	NEW DATA			PROGRAM RS-232-C PARITY: NONE
22.2	<input type="checkbox"/> or <input type="checkbox"/>	NONE, ODD, EVEN, MARK, or SPACE	Use arrow keys to display the type of parity used by the PC/printer.	
22.3	ENTER			

**Table 13-8:
Date and Time Programming**

STEP NO.	KEY PRESSED	DATA ENTRY KEY SEQUENCE	COMMENTS	MESSAGE DISPLAYED
23	<input type="checkbox"/>			PROGRAM DATE FRI 03 JAN 2008
23.1	NEW DATA			
23.2		##	Enter the day of the month. The entry must consist of two digits (01, 12, 27, etc.).	
23.3	<input type="checkbox"/> or <input type="checkbox"/>		Use arrow keys to display the desired month entry.	
23.4	NEW DATA			
23.5		####	Enter all four digits for the year entry (1999, 2000, etc.). As the last digit is entered, the applicable day of the week is automatically displayed.	
23.6			Review all time entries and change as necessary.	
23.7	ENTER			

NOTE

NOTE
If 24-hour (military) time format is used, be sure to enter the hours in the same format (01, 02 18, etc.).

**Table 13-8:
Date and Time Programming (Continued)**

STEP NO.	KEY PRESSED	DATA ENTRY KEY SEQUENCE	COMMENTS	MESSAGE DISPLAYED
24	<input type="checkbox"/>			PROGRAM TIME 12:45:56 (24 HR)
24.1	NEW DATA			
24.2		##	Enter hours. Entry must consist of two digits (01, 02, etc.).	

NOTE

NOTE

To ensure precise time setting, it may be helpful to set the minutes entry approximately two minutes ahead of the actual time to allow sufficient time to complete steps 24.4 and 24.5 below. Then, when the entered minutes time arrives, step 24.6 can be performed.

**Table 13-8:
Date and Time Programming (Concluded)**

STEP NO.	KEY PRESSED	DATA ENTRY KEY SEQUENCE	COMMENTS	MESSAGE DISPLAYED
24.3		##	Enter minutes. Entry must consist of two digits (06,12, 18, etc.).	PROGRAM TIME 12:45:56 (24 HR)
24.4		##	Enter seconds. Entry must consist of two digits (05, 15, 30, etc.).	
24.5	<input type="checkbox"/> or <input type="checkbox"/>	24 HR, AM, or PM	Use arrow keys to display desired time format entry.	
24.6	ENTER			
24.7			Verify that the seconds portion of the display is now advancing.	
25	<input type="checkbox"/>		Default is OFF .	PROGRAM DAYLIGHT SAVINGS: ON
25.1	NEW DATA		Each time NEW DATA key is pressed, entry toggles between OFF and ON . Select ON for daylight savings time. Select OFF for standard time.	
25.2	ENTER			

**Table 13-9:
Extended Application Programming**

STEP NO.	KEY PRESSED	DATA ENTRY KEY SEQUENCE	COMMENTS	MESSAGE DISPLAYED
26	FUNCTION		Default is EZ = 10 .	T1 SWITCH TO MS EZ LEVEL: 10
26.1	NEW DATA			
26.2		0 (OFF) to 100	Enter EZ level at which predictor to motion sensor switchover occurs.	
26.3	ENTER			
26.4			If system was programmed for one track in step 2.2, proceed to step 27.	
26.5	TRACK 2		If system was programmed for two tracks in step 2.2, press the TRACK 2 key and repeat steps 26.1 thru 26.3 for track 2.	
26.6	TRACK 1			

NOTE

NOTE

Safetran Systems software does not support the changes passed by the US Congress in regards to shifting Daylight Savings Time from the traditional dates as has been the case since the change became effective in October/November 2007.

**Table 13-9:
Extended Application Programming**

STEP NO.	KEY PRESSED	DATA ENTRY KEY SEQUENCE	COMMENTS	MESSAGE DISPLAYED
27	<input type="checkbox"/>		Default is 0 (OFF)	TRANSFER DELAY MS TO GCP T1: OFF
27.1	NEW DATA			
27.2		0 (OFF) to 500	Enter the time in seconds that the indicated track circuit will remain in the motion sensor mode before reverting to the grade crossing predictor mode.	

NOTE

NOTE

The Transfer Delay and the Advance Preempt Timer functions both exercise control of the MS/GCP CONTROL terminal; therefore, only one of these functions may be used at one time.

**Table 13-9:
Extended Application Programming (Continued)**

STEP NO.	KEY PRESSED	DATA ENTRY KEY SEQUENCE	COMMENTS	MESSAGE DISPLAYED
27.3	ENTER			TRANSFER DELAY MS TO GCP T1: OFF
27.4			If system was programmed for one track in step 2.2, proceed to step 27.7.	
27.5	TRACK 2		If system was programmed for two tracks in step 2.2, press the TRACK 2 key and repeat steps 27.1 thru 27.3 for track 2.	
27.6	TRACK 1			
27.7			If the system is equipped with an 80214 Processor having a revision level of A01E or later and a transfer delay value of 1 to 500 seconds is set in step 27.2, proceed to step 28	
27.8			If the system is equipped with an 80044 Processor module or the transfer delay value set in step 27.2 is 0 (OFF), proceed to step 29.	
28	▼		Message display when one or more DAX circuits are selected (step 12.2) and corresponding DAX distance values are assigned (step 14.2). When message displays, proceed to step 28.1. Default is OFF .	TRANSFER MS TO GCP DAX A: OFF
			Message display when no DAX circuits are selected (step 12.2) or no distance value is set for the assigned DAX (step 14.2). When message displays, proceed to step 29.1. Default is OFF .	
28.1	NEW DATA		Each time NEW DATA key is pressed, entry toggles between OFF and ON .	
28.2	ENTER		Press the ENTER key when the desired transfer status is displayed.	
28.3			If two or more DAX circuits are selected (step 12.2), repeat steps 28 thru 28.2 for each additional DAX circuit.	

WARNING

WARNING

ENTERING AN INCORRECT DAX AND/OR PRIME PREDICTION OFFSET DISTANCE MAY RESULT IN SHORT OR NO WARNING TIME WHEN A GCP TRACK CIRCUIT INCLUDES AN ISLAND, DO NOT USE PRIME PREDICTION OFFSET (PPO). WHEN A PPO DISTANCE (OTHER THAN 0) IS ENTERED, THE ISLAND CIRCUIT DOES NOT DE-ENERGIZE THE PRIME OUTPUT. THE WARNING SYSTEM WILL RECOVER WITH A TRAIN OCCUPYING THE ISLAND CIRCUIT AFTER THE PRIME PICKUP TIMER RUNS.

**Table 13-9:
Extended Application Programming (Continued)**

STEP NO.	KEY PRESSED	DATA ENTRY KEY SEQUENCE	COMMENTS	MESSAGE DISPLAYED
28.4	TRACK 2		If system was programmed for two tracks in step 2.2, press the TRACK 2 key and repeat steps 28.1 thru 28.3 for track 2.	TRANSFER MS TO GCP DAX A: OFF
28.5	TRACK 1			
29	<input type="checkbox"/>		Default is 0 (OFF)	PRIME PREDICTION OFFSET T1: OFF
29.1	NEW DATA			
29.2		0 (OFF) to 9999	Enter the prime prediction offset distance for the indicated track in feet.	
29.3	ENTER			
29.4			If system was programmed for one track in step 2.2, proceed to step 29.7.	
29.5	TRACK 2		If system was programmed for two tracks in step 2.2, press the TRACK 2 key and repeat steps 29.1 thru 29.3 for track 2.	
29.6	TRACK 1			
29.7			If the system is equipped with 80214 Processor Module having a revision level of A01E or later & prime prediction offset is set for a value greater than 0, proceed to step 30.	
29.8			If the prime prediction offset distance is set to OFF, proceed to step 32.	
30	<input type="checkbox"/>		Press and release the up arrow (▲) until the Transfer MS to GCP Prime message displays.	TRANSFER MS TO GCP PRIME T1: OFF
30.1	NEW DATA		Each time NEW DATA key is pressed, entry toggles between OFF and ON .	
30.2			Press the ENTER key when the desired transfer timer function is displayed.	
30.3	TRACK 2		If system was programmed for two tracks in step 2.2, press the TRACK 2 key and repeat steps 30.1 and 30.2 for track 2.	
30.4	TRACK 1			
31	▼		Press and release the down arrow (▼) until the Pickup Delay Prime message displays.	PICKUP DELAY PRIME: 15
31.1	NEW DATA			PICKUP DELAY PRIME: 15
31.2		8 to 500	Enter the length of time in seconds from the point at which motion ceases in the approach until the gates pick up.	
31.3	ENTER		Default is 15 seconds.	
32	▼		Default is 15 seconds. This step is applicable only when the system is programmed for one or more DAX.	PICKUP DELAY DAX A: 15
32.1	NEW DATA			
32.2		0 (OFF) to 500	Enter the length of time in seconds from the point at which motion ceases in the indicated DAX approach until the gates pick up when a train stops in the DAX approach.	
32.3	ENTER			
32.4			Repeat steps 32 thru 32.3 for each additional DAX circuit in the system (B, C, and D).	
33	<input type="checkbox"/>			



WARNING

THE DEFAULT COMPENSATION VALUE IS AUTOMATICALLY CALCULATED BY THE 3000 GCP SYSTEM. DO NOT CHANGE THIS VALUE WITHOUT PROPER INSTRUCTIONS.

**Table 13-9:
Extended Application Programming (Continued)**

STEP NO.	KEY PRESSED	DATA ENTRY KEY SEQUENCE	COMMENTS	MESSAGE DISPLAYED
33.1	NEW DATA			COMPENSATION VALUE T1: 1300
33.2		1000 to 2000	Enter the compensation value for the track indicated.	
33.3	ENTER			
33.4			If system was programmed for one track in step 2.2, proceed to step 33.7.	
33.5	TRACK 2		If system was programmed for two tracks in step 2.2, press the TRACK 2 key and repeat steps 33.1 thru 33.3 for track 2.	
33.6	TRACK 1			
33.7			If the system is equipped with an 80044 or 80214 Processor module, proceed to step 34.	
33.8			If the system is equipped with an 80014 Processor module, proceed to step 36.	
34	<input type="checkbox"/>		Default is OFF .	T1 ENHANCED DETECTION: *OFF

WARNING

WARNING

RUST BUILD-UP ON THE RAILS MAY NOT ALLOW TRACK SHUNTING TO OCCUR EVEN THOUGH ENHANCED DETECTION IS PROGRAMMED TO "ON." IF RUST WERE TO BUILD UP TO A DEGREE THAT NO TRACK SHUNTING OCCURS (EZ DOES NOT CHANGE), THE MODEL 3000 GCP WILL NOT SENSE TRAIN MOVEMENTS. DO NOT CONNECT THE DC SHUNTING ENHANCER PANEL 80049 TO THE MODEL 3000 GCP UAX (UAX1) TERMINALS IF OTHER WIRES ARE ALREADY CONNECTED TO THESE TERMINALS. IF THIS CONDITION EXISTS, CONTACT SAFETRAN ENGINEERING AT 1-800-793-7233 BEFORE PROCEEDING.

NOTE

NOTE

Intermittent poor shunting can result just about anywhere due to numerous causes but generally occurs due to infrequent track usage, lightly weighted cars, passenger and transit operation, spillage from rail cars, and rail contamination. Lack of any shunting generally occurs in dark territory where no DC or AC track circuits exist and few trains run. Track shunting in dark territory can be easily improved using methods similar to those employed in style-C track circuits. This involves the use of one insulated joint at the far end of each approach and the application of a DC voltage to the track at the crossing to improve shunting and thus allow the 3000 Enhanced Detection software to function properly. The Safetran DC Shunting Enhancer Panel, 80049, provides a cost effective solution for improving shunting in dark territory:

- A nominal 6 volts DC is applied to the track at the crossing to break down the film on the rails.
- This DC voltage is isolated from the battery.
- A minimum of two insulated joints are required, one at the far end of each approach.
- The DC Shunting Enhancement Panel can also be easily incorporated in applications involving overlapping approaches from two or more crossings.
- Narrow-band termination shunts must be used. Do not use wideband or hardwire shunts for terminations.

**Table 13-9:
Extended Application Programming (Continued)**

STEP NO.	KEY PRESSED	DATA ENTRY KEY SEQUENCE	COMMENTS	MESSAGE DISPLAYED
34.1	NEW DATA		The ED operating mode for track 1 toggles between ON and OFF each time the NEW DATA key is pressed.	T1 ENHANCED DETECTION: *OFF
34.2	ENTER		Press the ENTER key when the desired mode status is displayed.	
34.3			If system was programmed for one track in step 2.2, proceed to step 34.6.	
34.4	TRACK 2		If system was programmed for two tracks in step 2.2, press the TRACK 2 key and repeat steps 34.1 and 34.2 for track 2.	
34.5	TRACK 1			
34.6			If the ED operating mode is programmed to ON , proceed to step 35.	
34.7			If the ED operating mode is programmed to OFF , proceed to step 37.	
35	▼		Default is NO .	BACK TO BACK T1 AND T2: NO
35.1	NEW DATA		The back-to-back display toggles between NO and YES each time the NEW DATA key is pressed.	

NOTE

NOTE

Select YES when two unidirectional units are in the same Model 3000 GCP case and the associated approaches are located on opposite sides of the same pair of insulated joints and are at a crossing.

**Table 13-9:
Extended Application Programming (Continued)**

STEP NO.	KEY PRESSED	DATA ENTRY KEY SEQUENCE	COMMENTS	MESSAGE DISPLAYED
35.2	ENTER		Press the ENTER key when the applicable condition is displayed.	
36	▼		Default is 10 seconds.	STATION STOP TIMER T1: 10

WARNING

WARNING

IN SOFTWARE VERSIONS J AND EARLIER, WHEN THE STATION STOP TIMER IS PROGRAMMED TO A TIME OTHER THAN 10 SECONDS (MINIMUM VALUE), THERE MUST NOT BE ANY TRAIN MOVES APPROACHING THE CROSSING BETWEEN THE TIME A TRAIN LEAVES THE ISLAND AT THE CROSSING AND THE PROGRAMMED TIME OF THE STATION STOP TIMER ELAPSES.

NOTE

NOTE

In software versions J and earlier, the Station Stop Timer can be programmed to run for up to a maximum of 500 seconds, but should normally be left at the default setting of **10** seconds. The timer is initiated automatically after a train leaves the island circuit and operates in conjunction with the enhanced detection logic. If the train makes a station stop after passing the crossing, the timer can be programmed for up to 500 seconds to prevent tail rings due to poor shunting after the train has stopped and then departs from the station. This timer is active only if Enhanced Detection is programmed **ON**.

**Table 13-9:
Extended Application Programming (Continued)**

STEP NO.	KEY PRESSED	DATA ENTRY KEY SEQUENCE	COMMENTS	MESSAGE DISPLAYED
36.1	NEW DATA			STATION STOP TIMER T1: 10
36.2		10 to 500	Enter the required Station Stop Timer value in seconds on the alphanumeric keypad.	

NOTE

NOTE

This entry is used when a passenger station platform is located within the 3000 GCP approach. The value entered on the keypad establishes the time interval (in seconds) that the train stops in the station.

**Table 13-9:
Extended Application Programming (Continued)**

STEP NO.	KEY PRESSED	DATA ENTRY KEY SEQUENCE	COMMENTS	MESSAGE DISPLAYED
36.3	ENTER			STATION STOP TIMER T1: 10
36.4			If system was programmed for one track in step 2.2, proceed to step 37.	
36.5	TRACK 2		If system was programmed for two tracks in step 2.2, press the TRACK 2 key and repeat steps 36.1 thru 36.3 for track 2.	
36.6	TRACK 1			NUMBER OF TRACK WIRES T1: 4
37	<input type="checkbox"/>		Default is 4.	
37.1	NEW DATA			
37.2		4 to 6	Enter the number of track wires for the indicated track.	
37.3	ENTER			
37.4			If system was programmed for one track in step 2.2, proceed to step 37.7.	
37.5	TRACK 2		If system was programmed for two tracks in step 2.2, press the TRACK 2 key and repeat steps 37.1 thru 37.3 for track 2.	
37.6	TRACK 1			
37.7			If the system is equipped with an 80044 or 80214 Processor module, proceed to step 38.	
37.8			If the system is equipped with an 80014 Processor module, proceed to step 44.	
38	<input type="checkbox"/>		Default is 0. Optional, perform only if needed.	T1 LOW EX ADJUSTMENT: 0
38.1			If Low EX Adjustment is required for track 1, proceed to step 38.2; otherwise, proceed to step 38.6.	
38.2	NEW DATA			

WARNING

WARNING

DO NOT ARBITRARILY REDUCE THE EX OPERATING THRESHOLD. IMPROPER ADJUSTMENT MAY CAUSE SHORT OR NO WARNING TIME.

NOTE

NOTE

The EX operating threshold has already been reduced to 39 in the 80044 and 80214 processors and should be sufficiently low for most applications. Before reducing the threshold, thoroughly test the ballast at the location to determine whether conditions permit the threshold reduction (see SIG-00-00-02, Model 3000 GCP Instruction and Installation Manual, section 7, paragraph 7.7.3.2 for the Low EX Test Procedure).

**Table 13-9:
Extended Application Programming (Continued)**

STEP NO.	KEY PRESSED	DATA ENTRY KEY SEQUENCE	COMMENTS	MESSAGE DISPLAYED
38.3		0 to 5	Enter the low EX threshold adjustment value for the indicated track.	T1 LOW EX ADJUSTMENT: 0
38.4	ENTER			
38.5			If system was programmed for one track in step 2.2, proceed to step 38.8.	
38.6	TRACK 2		If system was programmed for two tracks in step 2.2, press the TRACK 2 key and repeat steps 38.2 thru 38.4 for track 2.	
38.7	TRACK 1			
38.8			If the system is equipped with an 80214 Processor module having a revision level of 9V121 – A01C or later, proceed to step 39.	
38.9			If the system is equipped with an 80044 Processor module or an 80214 Processor module with a revision level of 9V121 – A01B or earlier, proceed to step 44.	
39	<input type="checkbox"/>		Default is OFF .	LOW EZ DETECTION EZ=70 T1:OFF
39.1	NEW DATA		The entry toggles between NO and YES each time the NEW DATA key is pressed.	

NOTE

When programmed ON this function detects a significant reduction of EZ. Low EZ detection occurs when EZ is constantly less than 70 for a period of time exceeding the Low EZ Detection Timer value (see Section 4, SIG-00-00-02, Model 3000 GCP Instruction and Installation Manual paragraph 4.17.4).

**Table 13-9:
Extended Application Programming (Continued)**

STEP NO.	KEY PRESSED	DATA ENTRY KEY SEQUENCE	COMMENTS	MESSAGE DISPLAYED
39.2	ENTER		Press the ENTER key when the desired EZ detection entry is displayed.	LOW EZ DETECTION EZ=70 T1:OFF
39.3			If system was programmed for one track in step 2.2, proceed to step 39.6.	
39.4	TRACK 2		If system was programmed for two tracks in step 2.2, press the TRACK 2 key and repeat steps 39.1 and 39.2 for track 2.	LOW EZ DETECTION EZ=70 T1:OFF
39.5	TRACK 1			
39.6			If low EZ detection is programmed to ON , proceed to step 40.	
39.7			If low EZ detection is programmed to OFF , proceed to step 41.	
40	<input type="checkbox"/>		Default is 10 minutes.	LOW EZ DETECTION TIMER T1: 10
40.1	NEW DATA			
40.2		02 to 99 minutes	Enter the low EZ detection timer value in minutes.	

NOTE

NOTE
This value is the time between the detection of a low EZ value and the de-energizing of the associated track prime and DAX relay drive outputs.

**Table 13-9:
Extended Application Programming (Continued)**

STEP NO.	KEY PRESSED	DATA ENTRY KEY SEQUENCE	COMMENTS	MESSAGE DISPLAYED
40.3	ENTER			LOW EZ DETECTION TIMER T1: 10
40.4			If the system is programmed for one track (step 2.2), proceed to step 41.	
40.5	TRACK 2		If system was programmed for two tracks in step 2.2, press the TRACK 2 key and repeat steps 40.1 thru 40.3 for track 2.	
40.6	TRACK 1			
41	<input type="checkbox"/>		Default is OFF .	POSITIVE START EZ LEVEL T1: OFF
41.1	NEW DATA			

NOTE

NOTE

When programmed, the positive start function enables the immediate activation of the crossing warning device whenever the track circuit EZ level drops below the programmed positive start EZ value.

**Table 13-9:
Extended Application Programming (Continued)**

STEP NO.	KEY PRESSED	DATA ENTRY KEY SEQUENCE	COMMENTS	MESSAGE DISPLAYED
41.2		0 (OFF) to 99	Enter the positive start EZ level value.	POSITIVE START EZ LEVEL T1: OFF
41.3	ENTER			
41.4			If system was programmed for one track in step 2.2, proceed to step 41.7.	
41.5	TRACK 2		If system was programmed for two tracks in step 2.2, press the TRACK 2 key and repeat steps 41.1 thru 41.3 for track 2.	
41.6	TRACK 1			
41.7			If the positive start EZ level value is set to 00 (NONE) , proceed to step 43.	
41.8			If the positive start EZ level value is set to a value between 01 and 99 , proceed to step 42.	
42	<input type="checkbox"/>		Default is NONE .	POSITIVE START TIMEOUT T1: NONE

NOTE

NOTE

This display appears only when the Positive Start EZ Level option is enabled.

**Table 13-9:
Extended Application Programming (Continued)**

STEP NO.	KEY PRESSED	DATA ENTRY KEY SEQUENCE	COMMENTS	MESSAGE DISPLAYED
42.1	NEW DATA			POSITIVE START TIMEOUT T1: NONE
42.2		NONE (0) to 99	Enter the positive start timeout value.	

NOTE

NOTE

The programmed value determines when Continuous Positive Start timeout will occur.

**Table 13-9:
Extended Application Programming (Continued)**

STEP NO.	KEY PRESSED	DATA ENTRY KEY SEQUENCE	COMMENTS	MESSAGE DISPLAYED
42.3	ENTER			POSITIVE START TIMEOUT T1: NONE
42.4			If system was programmed for one track in step 2.2, proceed to step 43.	
42.5	TRACK 2		If system was programmed for two tracks in step 2.2, press the TRACK 2 key and repeat steps 42.1 thru 42.3 for track 2.	
42.6	TRACK 1			
43	<input type="checkbox"/>		Default is NORMAL .	
43.1	NEW DATA		The entry toggles between NORMAL and DIAGNOSTICS each time the NEW DATA key is pressed.	

NOTE

NOTE

This function allows the automatic transfer (AT) output to be utilized either as a drive for an external Automatic Transfer unit or as an error indication signal. To select normal External Automatic Transfer unit operation, select NORMAL. To select the AT error indication function, select DIAGNOSTICS.

**Table 13-9:
Extended Application Programming (Continued)**

STEP NO.	KEY PRESSED	DATA ENTRY KEY SEQUENCE	COMMENTS	MESSAGE DISPLAYED
43.2	ENTER		Press the ENTER key when the desired automatic transfer function is displayed.	SET AT OPERATION OUT: NORMAL
43.3			If a Data Recorder Module or a SEAR node is installed, proceed to step 44.	
43.4			If no data recorder is installed, proceed to step 46.	
44	<input type="checkbox"/>		Default is ON .	DIAGNOSTIC MESSAGES: ON
44.1	NEW DATA		The entry toggles between ON and OFF each time the NEW DATA key is pressed.	

NOTE

NOTE

This display appears only when a Data Recorder module is installed or when a SEAR Node has been programmed into the GCP from a SEAR. When programmed ON, this function allows a large number of new GCP diagnostic messages to be sent to either the Data Recorder module or the SEAR/R recorder by the 80214 software.

**Table 13-9:
Extended Application Programming (Continued)**

STEP NO.	KEY PRESSED	DATA ENTRY KEY SEQUENCE	COMMENTS	MESSAGE DISPLAYED
44.2	ENTER		Press the ENTER key when the desired entry is displayed.	DIAGNOSTIC MESSAGES: ON
44.3			If Diagnostic Messages are programmed to ON , proceed to step 45.	DIAGNOSTIC MESSAGES: ON
44.4			If Diagnostic Messages are programmed to OFF , proceed to step 46.	
45	<input type="checkbox"/>		Default is ON .	DAX MESSAGES: OFF
45.1	NEW DATA		The entry toggles between ON and OFF each time the NEW DATA key is pressed.	
45.2	ENTER		Press the ENTER key when the desired entry is displayed.	

**Table 13-9:
Extended Application Programming (Continued)**

STEP NO.	KEY PRESSED	DATA ENTRY KEY SEQUENCE	COMMENTS	MESSAGE DISPLAYED
46	<input type="checkbox"/>		Default is OFF.	ADVANCE PREEMPT TIMER: OFF
46.1	NEW DATA			
46.2		OFF (0) to 99	Enter the advance preempt timer value.	
46.3	ENTER		Press the ENTER key when the desired entry is displayed.	
47	<input type="checkbox"/>		Default is NORMAL .	MOTION SENSING LEVEL T1: NORMAL

NOTE

NOTE
This function is normally used in conjunction with Transfer Delay timer operation.

**Table 13-9:
Extended Application Programming (Continued)**

STEP NO.	KEY PRESSED	DATA ENTRY KEY SEQUENCE	COMMENTS	MESSAGE DISPLAYED
47.1	NEW DATA			MOTION SENSING LEVEL T1: NORMAL
47.2		NORMAL 0 to 99	Enter the motion sensor level value.	

NOTE

NOTE
The motion sensing level function enables control of motion sensitivity. An entry of 0 (zero) produces a **NORMAL** indication on the display and establishes motion sensitivity of approximately 30 mph at end of a 3000-foot approach. An entry of 100 produces maximum motion sensitivity of approximately 1 mph at the feed points and 2 mph within the approach(es).

Table 13-9: Extended Application Programming (Concluded)

STEP NO.	KEY PRESSED	DATA ENTRY KEY SEQUENCE	COMMENTS	MESSAGE DISPLAYED
47.3	ENTER		Press the ENTER key when the desired entry is displayed.	
47.4			If system was programmed for one track in step 2.2, proceed to step 48.	
47.5			If system was programmed for two tracks in step 2.2, press the TRACK 2 key and repeat steps 47.1 through 47.3 for track 2.	
48	<input type="checkbox"/>		See step 1.	SET TO DEFAULT

SECTION 14 – MODEL 3000 GCP APPLICATION DIAGRAMS

This section provides a variety of figures depicting typical Model 3000 GCP applications. Also included are equipment wiring and mounting diagrams as well as module cross reference charts. Figure 14-1 through Figure 14-40 depicts application drawings; mounting dimensions are provided in Figure 14-41, Figure 14-42, and Figure 14-43; and Module and case cross reference data is provided in Figure 14-44 through Figure 14-49. The table below provides a cross reference listing of the illustrations contained within this section:

**Table 14-1:
Table of Application Drawings, Mounting Dimensions, and Module Selection Charts**

FIGURE NO.	TITLE
Figure 14-1	Recommended Surge Suppression Wiring for Microprocessor Based Grade Crossing Predictor, Model 3000 Family
Figure 14-2	Typical Model 3000/3000D2 GCP Bidirectional Application, One Track, Case Wiring
Figure 14-3	Typical Model 3000/3000D2 GCP Bidirectional Application, One Track, Track Wiring
Figure 14-4	Typical Model 3000/3000D2 GCP Bidirectional Application, Two Tracks, Case Wiring
Figure 14-5	Typical Model 3000/3000D2 GCP Bidirectional Application, Two Tracks, Track Wiring
Figure 14-6	Typical Model 3000/3000D2 GCP Unidirectional Application, One Track, Back-to-Back, Case Wiring
Figure 14-7	Typical Model 3000/3000D2 GCP Unidirectional Application, One Track, Back-to-Back, Track Wiring
Figure 14-8	Typical Model 3000/3000D2/3000D2L GCP Unidirectional Application, Two Tracks, Back-to-Back, Case Wiring
Figure 14-9	Typical Model 3000/3000D2/3000D2L GCP Unidirectional Application, Two Tracks, Back-to-Back, Track Wiring
Figure 14-10	Typical Model 3000ND/3000ND2 GCP Bidirectional Application, One Track
Figure 14-11	Typical Model 3000ND/3000ND2 GCP Unidirectional Application, One Track
Figure 14-12	Typical Model 3000ND/3000ND2 GCP Bidirectional Application with Crossover in MS/GCP Approach, Two Tracks (with Crossover Relay Logic), North Unit
Figure 14-13	Typical Model 3000ND/3000ND2 GCP Bidirectional Application with Crossover in MS/GCP Approach, Two Tracks (with Crossover Relay Logic), South Unit
Figure 14-14	Typical Model 3000ND/3000ND2 GCP Bidirectional Application with Crossover in MS/GCP Approach, Two Tracks (with Crossover Relay Logic), North or South Units, Track Wiring
Figure 14-15	Proper Model 3000 GCP Four-Wire and Six-Wire Connections Using Auxiliary Track Circuit Equipment on 3000 GCP Operating in the Bidirectional Simulation Mode
Figure 14-16	Typical Model 3000ND2 GCP Unidirectional Application with DC Island Track Circuit, One Track, Six Wire Hookup, Case Wiring
Figure 14-17	Typical Model 3000ND2 GCP Unidirectional Application with DC Island Track Circuit, One Track, Six Wire Hookup, Track Wiring
Figure 14-18	Typical Model 3000/3000D2 GCP Bidirectional Application with DC Island Track Circuit, One Track, Case Wiring
Figure 14-19	Typical Model 3000/3000D2 GCP Bidirectional Application with DC Island Track Circuit, One Track, Track Wiring
Figure 14-20	Typical Model 3000/3000D2 GCP Unidirectional Application with DC Island Track Circuit, One Track, Case Wiring

**Table 14-1:
Table of Application Drawings, Mounting Dimensions, and Module Selection Charts**

FIGURE NO.	TITLE
Figure 14-21	Typical Model 3000/3000D2 GCP Unidirectional Application with DC Island Track Circuit, One Track, Track Wiring
Figure 14-22	Typical Model 3000/3000D2 GCP Motion Sensor Application plus Track Wraps of MSR with Style 'C' Track Circuit, One Track, Case Wiring
Figure 14-23	Typical Model 3000/3000D2 GCP Motion Sensor Application plus Track Wraps of MSR with Style 'C' Track Circuit, One Track, Track Wiring
Figure 14-24	Typical Model 3000/3000D2 GCP Bidirectional Application with Remote Unidirectional Unit, One Track (Four-Wire), Case Wiring
Figure 14-25	Typical Model 3000/3000D2 GCP Bidirectional Application with Remote Unidirectional Unit, One Track (Four-Wire), Track Wiring
Figure 14-26	Typical Model 3000/3000D2 GCP Bidirectional Application, Unidirectional Unit With Remote Feed Point, One Track (Six-Wire), Case Wiring
Figure 14-27	Typical Model 3000/3000D2 GCP Bidirectional Application, Unidirectional Unit with Remote Feed Point, One Track (Six-Wire), Track Wiring
Figure 14-28	Typical Model 3000/3000D2 GCP Bidirectional UAX Interconnect Application with Remote Unidirectional Unit, One Track, Case Wiring
Figure 14-29	Typical Model 3000/3000D2 GCP Bidirectional UAX Interconnect Application with Remote Unidirectional Unit, One Track, Track Wiring
Figure 14-30	Typical Model 3000/3000D2/3000D2L GCP Unidirectional Application with Frequency Slaving and Cascaded Relay Drives, Two Tracks, Case Wiring
Figure 14-31	Typical Model 3000/3000D2/3000D2L GCP Unidirectional Application with Frequency Slaving and Cascaded Relay Drives, Two Tracks, Track Wiring
Figure 14-32	Typical Model 3000/3000D2 GCP Bidirectional Application with External Automatic Transfer, One Track
Figure 14-33	Typical Model 3000/3000D2/3000D2L GCP DAX-UAX Interconnections, Two Crossings
Figure 14-34	Typical Model 3000/3000D2/3008/3008D2 GCP Bidirectional Applications with Remote Unit, Multiple DAXing, One Track, Case Wiring
Figure 14-35	Typical Model 3000/3000D2/3008/3008D2 GCP Bidirectional Applications with Remote Model 3000/3000D2 Unit, Multiple DAXing, One Track, Track Wiring
Figure 14-36	Typical Model 3000/3000D2 GCP Bidirectional Advanced Preempt Timer Application, One Track, Case Wiring
Figure 14-37	Typical Model 3000/3000D2 GCP Bidirectional DAX-UAX Interconnect Advanced Preempt Timer Application, One Track, Case Wiring
Figure 14-38	Typical Model 3000/3000D2 GCP Bidirectional Switch to Motion Sensor Application, One Track, Case Wiring
Figure 14-39	Typical Model 3000/3000D2 GCP Bidirectional DAX-UAX Interconnect Switch to Motion Sensor Application, One Track, Case Wiring
Figure 14-40	Steady Energy DC Track Circuit with 100 Hz Cab Signal
Figure 14-41	Mounting Dimensions, Model 3000, 3000ND, 3000ND2, and 3008 GCPs
Figure 14-42	Mounting Dimensions, Model 3000D2 and 3008D2 GCPs
Figure 14-43	Mounting Dimensions, Model 3000D2L GCP
Figure 14-44	Model 3000 GCP Module Selection Chart
Figure 14-45	Model 3000D2 GCP Module Selection Chart

Table 14-1:
Table of Application Drawings, Mounting Dimensions, and Module Selection Charts

FIGURE NO.	TITLE
Figure 14-46	Model 3000ND GCP Module Selection Chart
Figure 14-47	Model 3000ND2 GCP Module Selection Chart
Figure 14-48	Model 3008 GCP Module Selection Chart
Figure 14-49	Model 3008D2 GCP Module Selection Chart

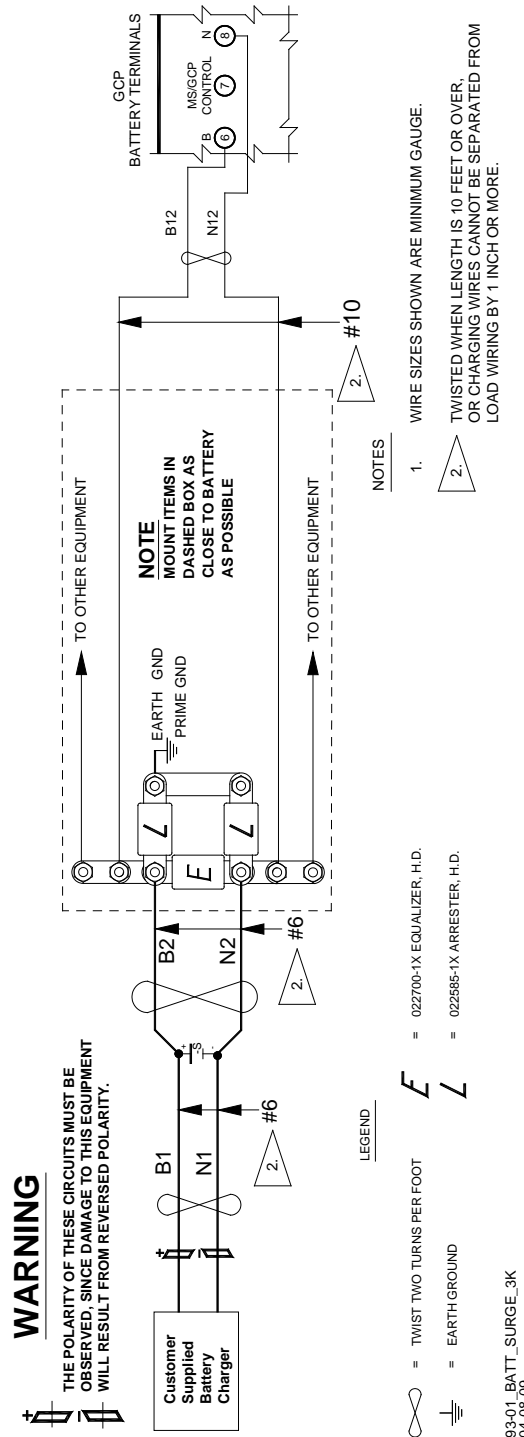
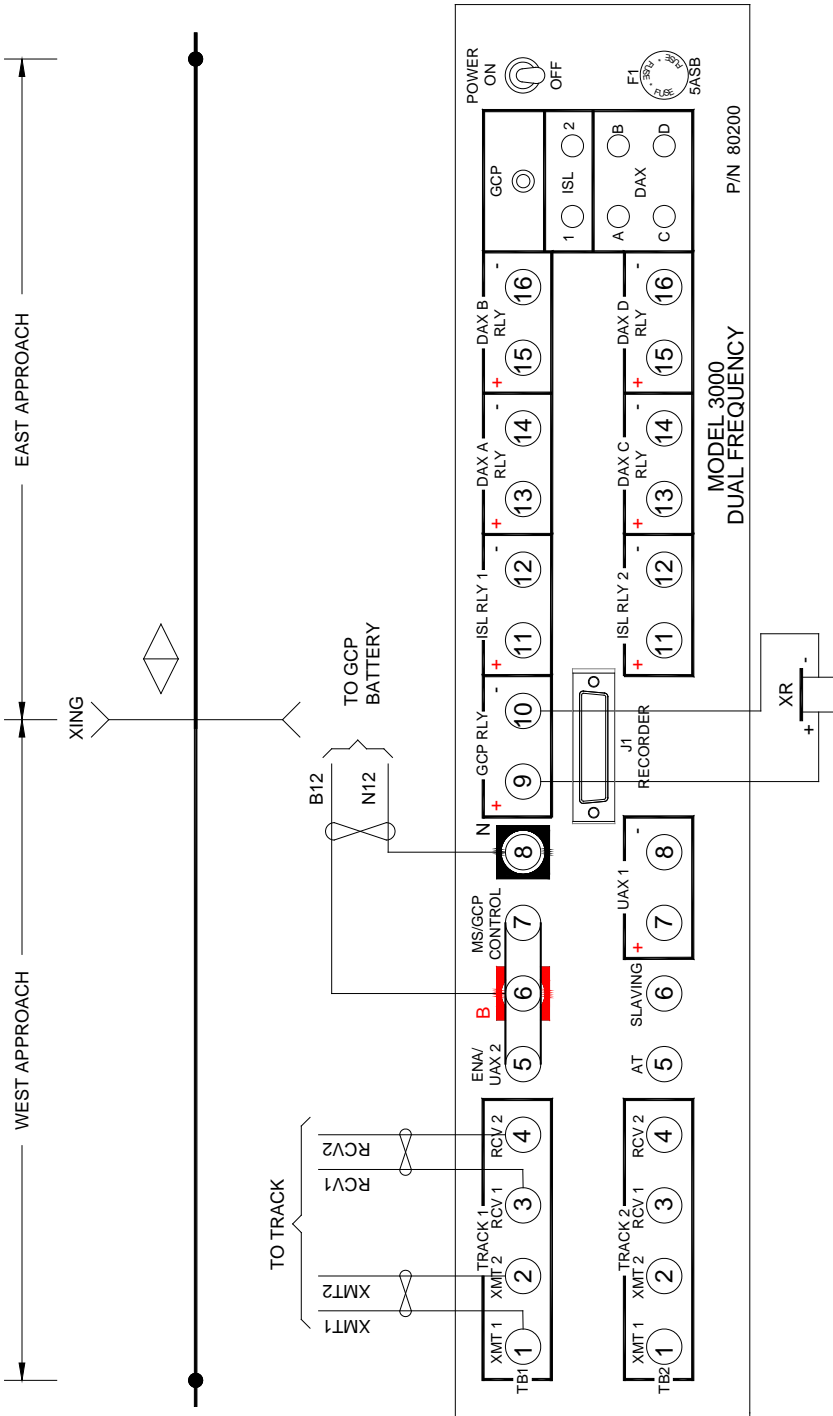


Figure 14-1: Recommended Surge Suppression Wiring for Microprocessor Based Grade Crossing Predictor, Model 3000 Family



WARNING

APPROACH DISTANCES MUST PROVIDE A MINIMUM OPERATING TIME EQUAL TO PRIME WARNING TIME SELECTED (OR PREEMPT WARNING, IF USED) PLUS 4 SECONDS FOR SYSTEM RESPONSE TIME AT MAXIMUM TRAIN SPEED.

NEVER WIRE WRAP AROUND RELAY FRONT CONTACTS BETWEEN GCP RLY (+) TB1-9 AND ENA (+) TB1-5.

LEGEND

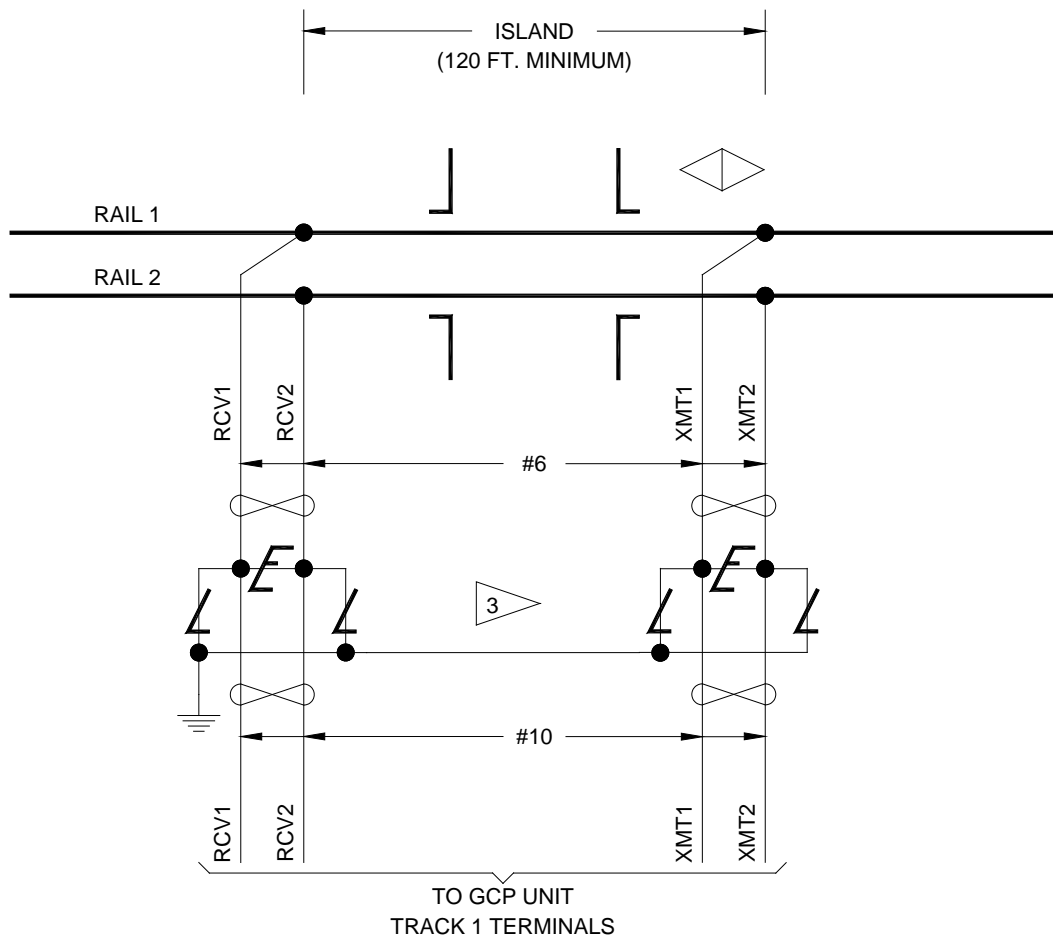
- = TWIST TWO TURNS PER FOOT
- = BIDIRECTIONAL GCP UNIT
- = TERMINATION SHUNT

NOTES

1. ALL WIRING #16 AWG MINIMUM UNLESS OTHERWISE NOTED. WIRE SIZES SHOWN ARE MINIMUM GAUGE.
2. TERMINATION SHUNTS MAY BE HARDWIRE, WIDEBAND, OR NARROW-BAND, DEPENDING UPON TYPE OF TRACK CIRCUIT IN USE. THE USE OF DUAL WIDEBAND SHUNTS, PART NUMBER 8A077, IS NOT RECOMMENDED FOR 3000 GCP APPLICATIONS.
3. SEE FIGURE 14-3 FOR GCP-TO-TRACK WIRING.
4. SEE FIGURE 14-1 FOR GCP BATTERY CONNECTIONS AND CHARGING CIRCUIT.
5. SEE FIGURE 14-44 AND 14-45 FOR MODULE REQUIREMENTS

93-01_TYP_3K_BI_1T_CASE
04-08-09






Figure 14-2: Typical Model 3000/3000D2 GCP Bidirectional Application, One Track, Case Wiring



NOTES

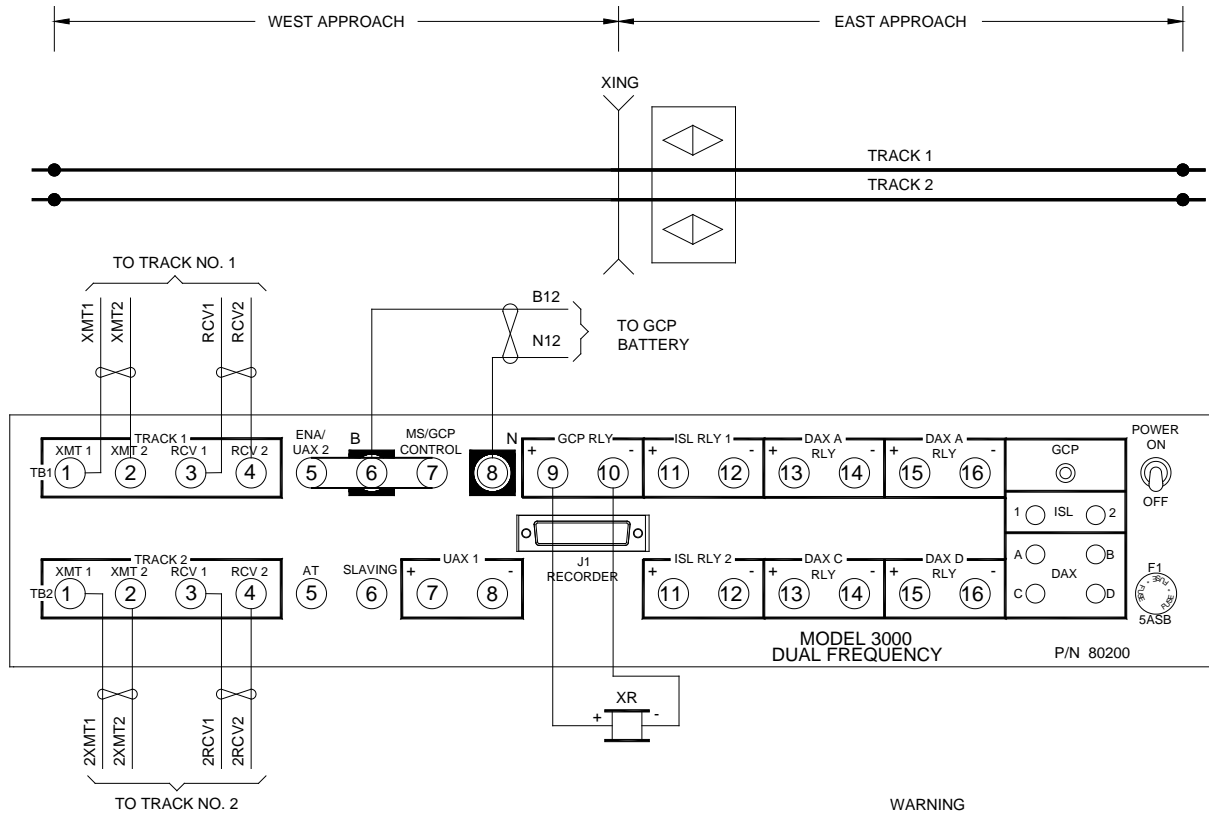
1. ALL WIRING #16 AWG MINIMUM UNLESS OTHERWISE NOTED. WIRE SIZES SHOWN ARE MINIMUM GAUGE.
2. SEE SECTION 7 FOR DETAILED TRACK INFORMATION.
3. ARRESTERS AND EQUALIZERS MOUNTED ON SURGE PANELS (80026-XX). SEE PARAGRAPH 12.6 FOR DETAILS.

LEGEND

- | | | | |
|---|-----------------------------|---|--------------------------|
|  | = TWIST TWO TURNS PER FOOT |  | = EARTH GROUND |
|  | = 022700-1X EQUALIZER, H.D. |  | = BIDIRECTIONAL GCP UNIT |
|  | = 022585-1X ARRESTER, H.D. | | |

93-01_TYP_3K-3KD2_BI_1T_TRACK
04-08-09

Figure 14-3: Typical Model 3000/3000D2 GCP Bidirectional Application, One Track, Track Wiring

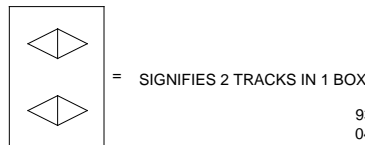


NOTES

1. ALL WIRING #16 AWG MINIMUM UNLESS OTHERWISE NOTED. WIRE SIZES SHOWN ARE MINIMUM GAUGE.
2. TERMINATION SHUNTS MAY BE HARDWIRE, WIDEBAND, OR NARROW-BAND, DEPENDING UPON TYPE OF TRACK CIRCUIT IN USE. THE USE OF DUAL WIDEBAND SHUNTS, PART NUMBER 8A077, IS NOT RECOMMENDED FOR 3000 GCP APPLICATIONS.
3. SEE FIGURE 14-5 FOR GCP-TO-TRACK WIRING.
4. SEE FIGURE 14-3 FOR GCP BATTERY CONNECTIONS AND CHARGING CIRCUIT.
5. SEE FIGURES 14-44 AND 14-45 FOR MODULE REQUIREMENTS

LEGEND

- = TWIST TWO TURNS PER FOOT
- = BIDIRECTIONAL GCP UNIT
- = TERMINATION SHUNT



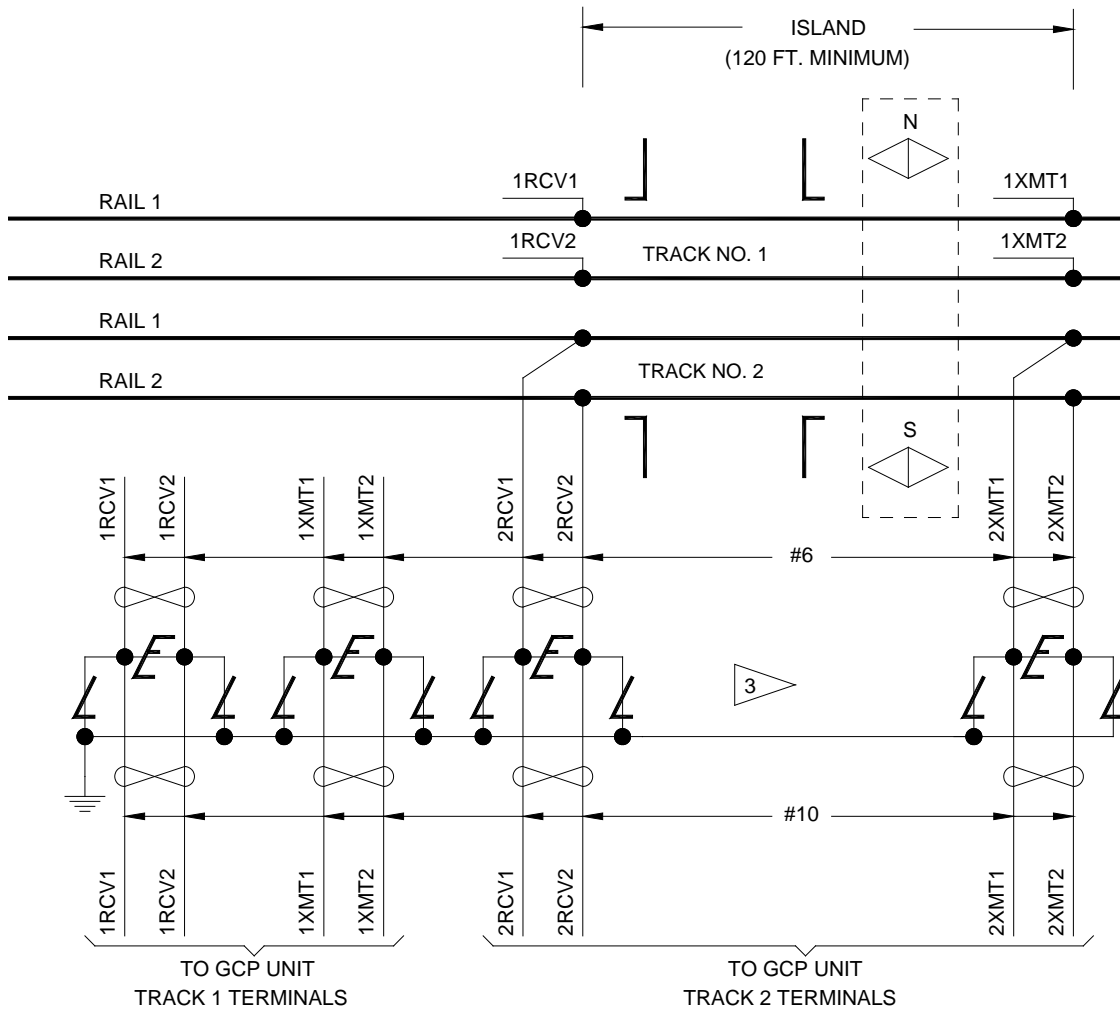
WARNING

APPROACH DISTANCES MUST PROVIDE A MINIMUM OPERATING TIME EQUAL TO PRIME WARNING TIME SELECTED (OR PREEMPT WARNING, IF USED) PLUS 4 SECONDS FOR SYSTEM RESPONSE TIME AT MAXIMUM TRAIN SPEED.

NEVER WIRE WRAP AROUND RELAY FRONT CONTACTS BETWEEN GCP RLY (+) TB1-9 AND ENA (+) TB1-5.

93-01_TYP_3K-3KD2_BI_2T_CASE
04-08-09






Figure 14-4: Typical Model 3000/3000D2 GCP Bidirectional Application, Two Tracks, Case Wiring



NOTES

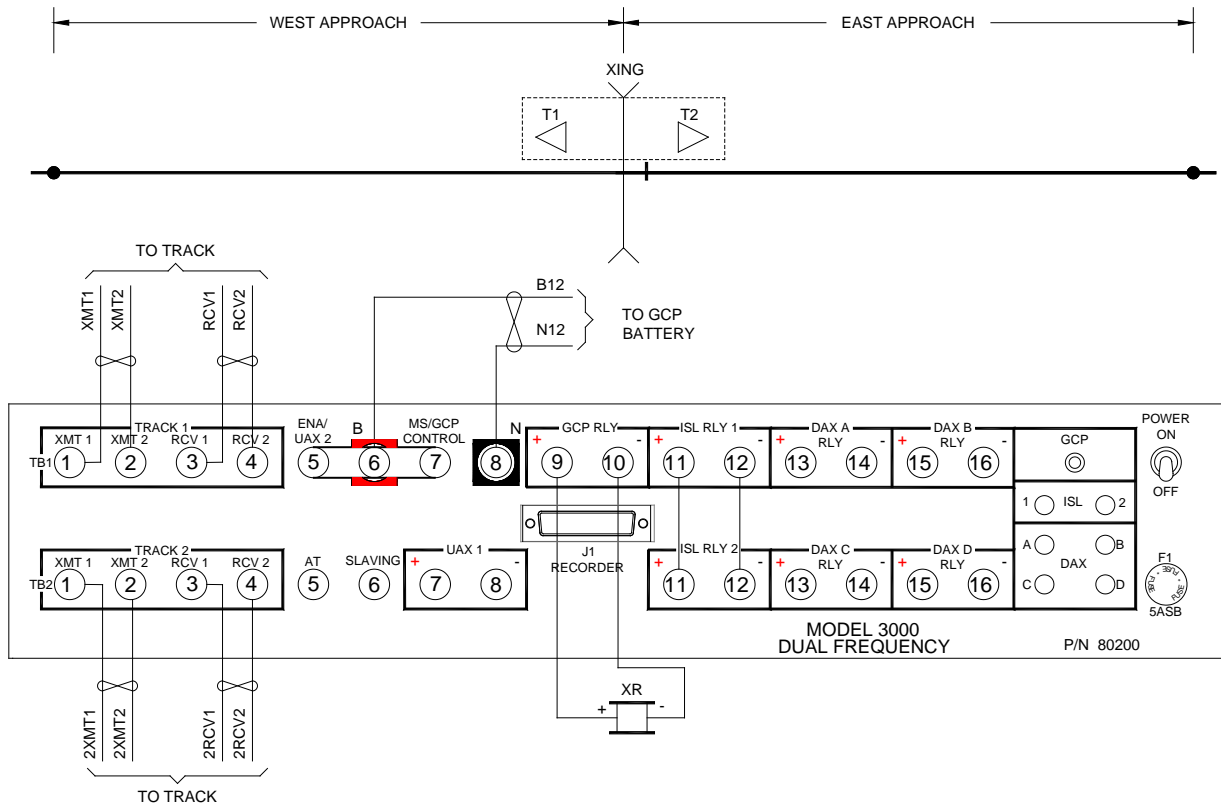
1. ALL WIRING #16 AWG MINIMUM UNLESS OTHERWISE NOTED. WIRE SIZES SHOWN ARE MINIMUM GAUGE.
2. SEE SECTION 7 FOR DETAILED TRACK INFORMATION.
3. ARRESTERS AND EQUALIZERS MOUNTED ON SURGE PANELS (80026-XX). SEE PARAGRAPH 12.6 FOR DETAILS.

LEGEND

-  = TWIST TWO TURNS PER FOOT
-  = 022700-1X EQUALIZER, H.D.
-  = 022585-1X ARRESTER, H.D.
-  = BIDIRECTIONAL GCP UNIT
-  = EARTH GROUND

93-01_TYP_3K-3KD2_BI_2T_TRACK
04-08-09

Figure 14-5: Typical Model 3000/3000D2 GCP Bidirectional Application, Two Tracks, Track Wiring

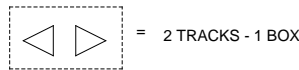


NOTES

1. ALL WIRING #16 AWG MINIMUM UNLESS OTHERWISE NOTED. WIRE SIZES SHOWN ARE MINIMUM GAUGE.
2. TERMINATION SHUNTS MAY BE HARDWIRE, WIDEBAND, OR NARROW-BAND, DEPENDING UPON TYPE OF TRACK CIRCUIT IN USE. THE USE OF DUAL WIDEBAND SHUNTS, PART NUMBER 8A077, IS NOT RECOMMENDED FOR 3000 GCP APPLICATIONS.
3. SEE FIGURE 14-7 FOR GCP-TO-TRACK WIRING.
4. SEE FIGURE 14-1 FOR GCP BATTERY CONNECTIONS AND CHARGING CIRCUIT.
5. SEE FIGURES 14-44 AND 14-45 FOR MODULE REQUIREMENTS.

LEGEND

- = TWIST TWO TURNS PER FOOT
- = UNIDIRECTIONAL GCP UNIT
- = TERMINATION SHUNT



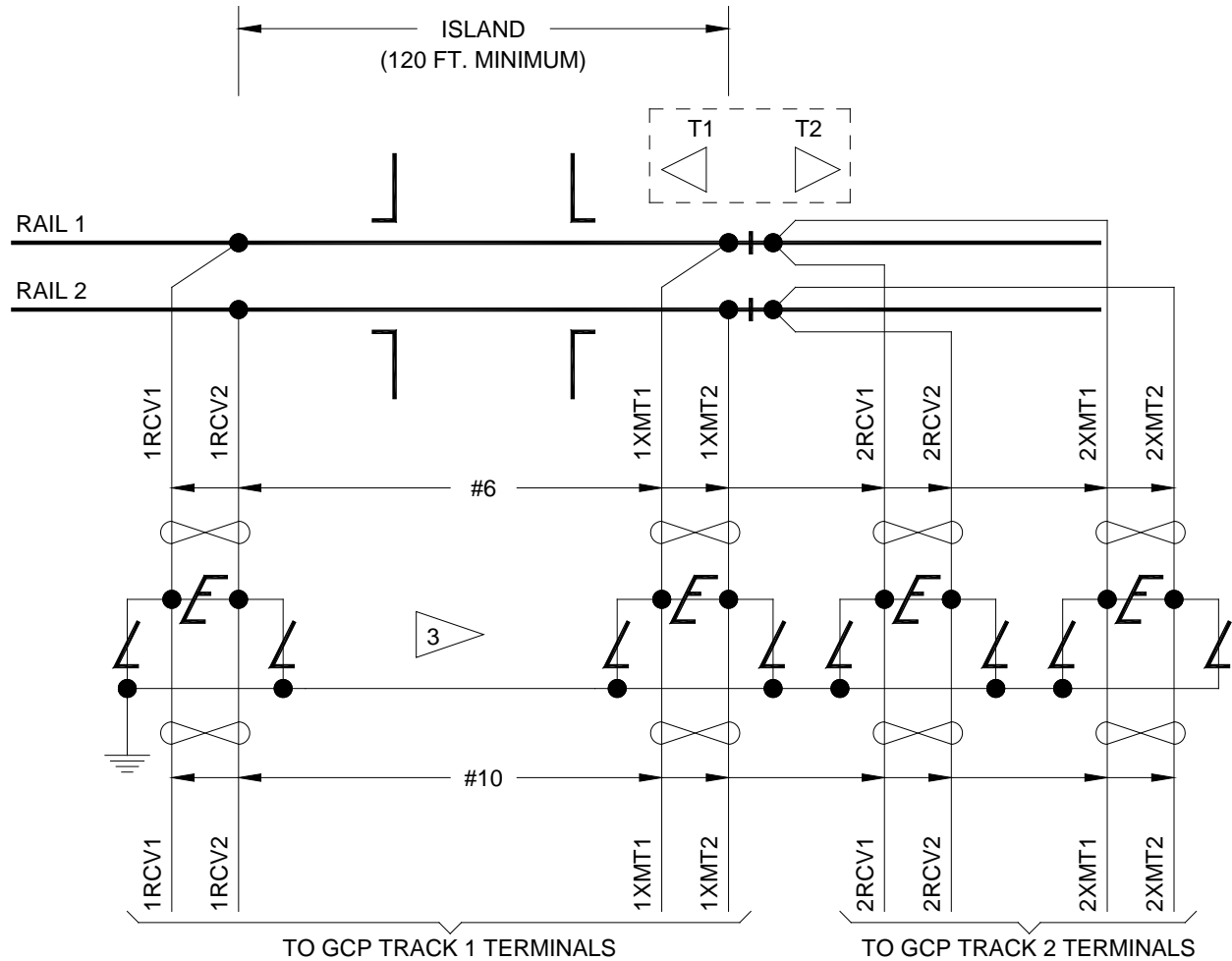
WARNING

APPROACH DISTANCES MUST PROVIDE A MINIMUM OPERATING TIME EQUAL TO PRIME WARNING TIME SELECTED (OR PREEMPT WARNING, IF USED) PLUS 4 SECONDS FOR SYSTEM RESPONSE TIME AT MAXIMUM TRAIN SPEED.

NEVER WIRE WRAP AROUND RELAY FRONT CONTACTS BETWEEN GCP RLY (+) TB1-9 AND ENA (+) TB1-5.

93-01_TYP_3K-3KD2_UNI_B2B_CASE
04-08-09

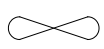
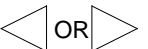



Figure 14-6: Typical Model 3000/3000D2 GCP Unidirectional Application, One Track, Back-to-Back, Case Wiring



NOTES

1. ALL WIRING #16 AWG MINIMUM UNLESS OTHERWISE NOTED. WIRE SIZES SHOWN ARE MINIMUM GAUGE.
2. SEE SECTION 7 FOR DETAILED TRACK INFORMATION.
3. ARRESTERS AND EQUALIZERS MOUNTED ON SURGE PANELS (80026-XX). SEE PARAGRAPH 12.6 FOR DETAILS.

LEGEND

- | | | | |
|---|-----------------------------|---|---------------------------|
|  | = TWIST TWO TURNS PER FOOT |  | = UNIDIRECTIONAL GCP UNIT |
|  | = 022700-1X EQUALIZER, H.D. |  | = EARTH GROUND |
|  | = 022585-1X ARRESTOR, H.D. | | |

93-01_TYP_3K-3KD2_UNI_B2B_TRACK
04-08-09

Figure 14-7: Typical Model 3000/3000D2 GCP Unidirectional Application, One Track, Back-to-Back, Track Wiring

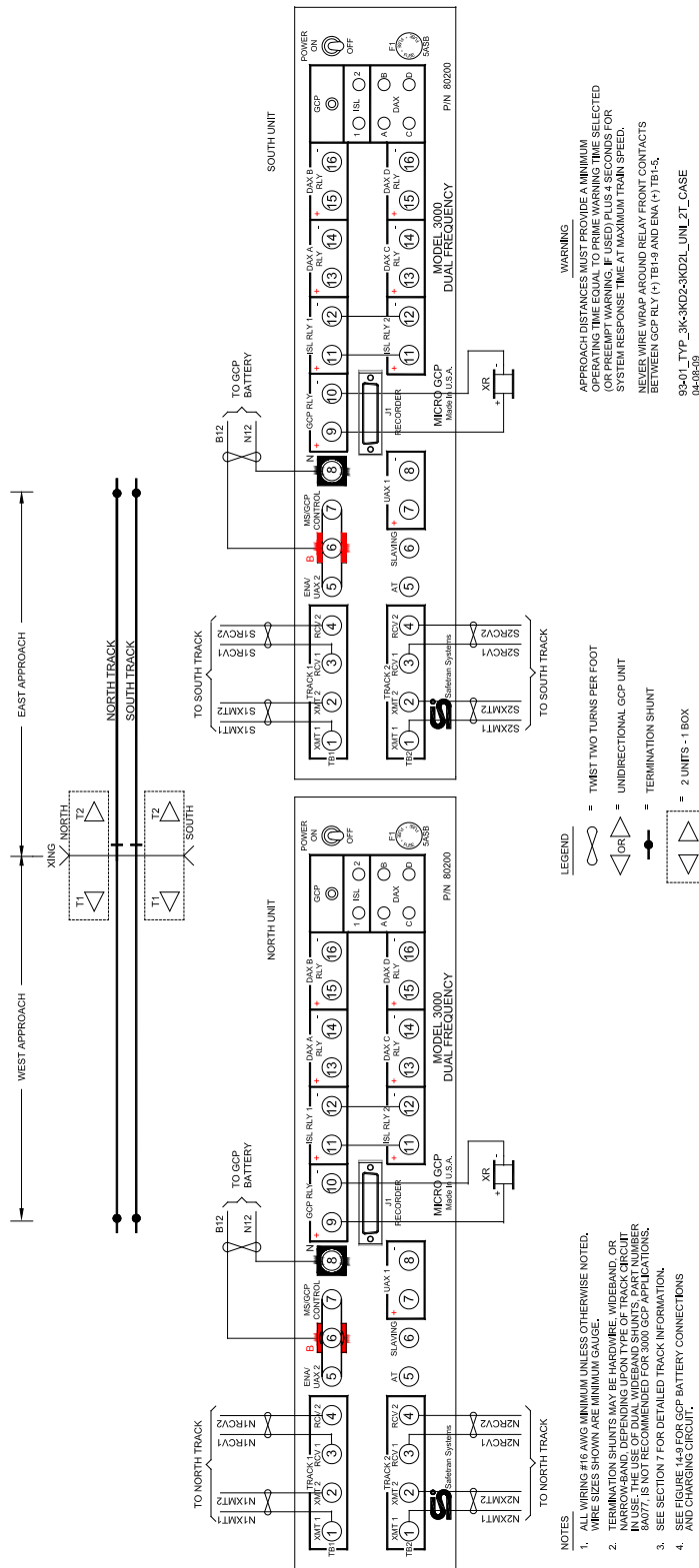


Figure 14-8: Typical Model 3000/3000D2/3000D2L GCP Unidirectional Application, Two Tracks, Back-to-Back, Case Wiring

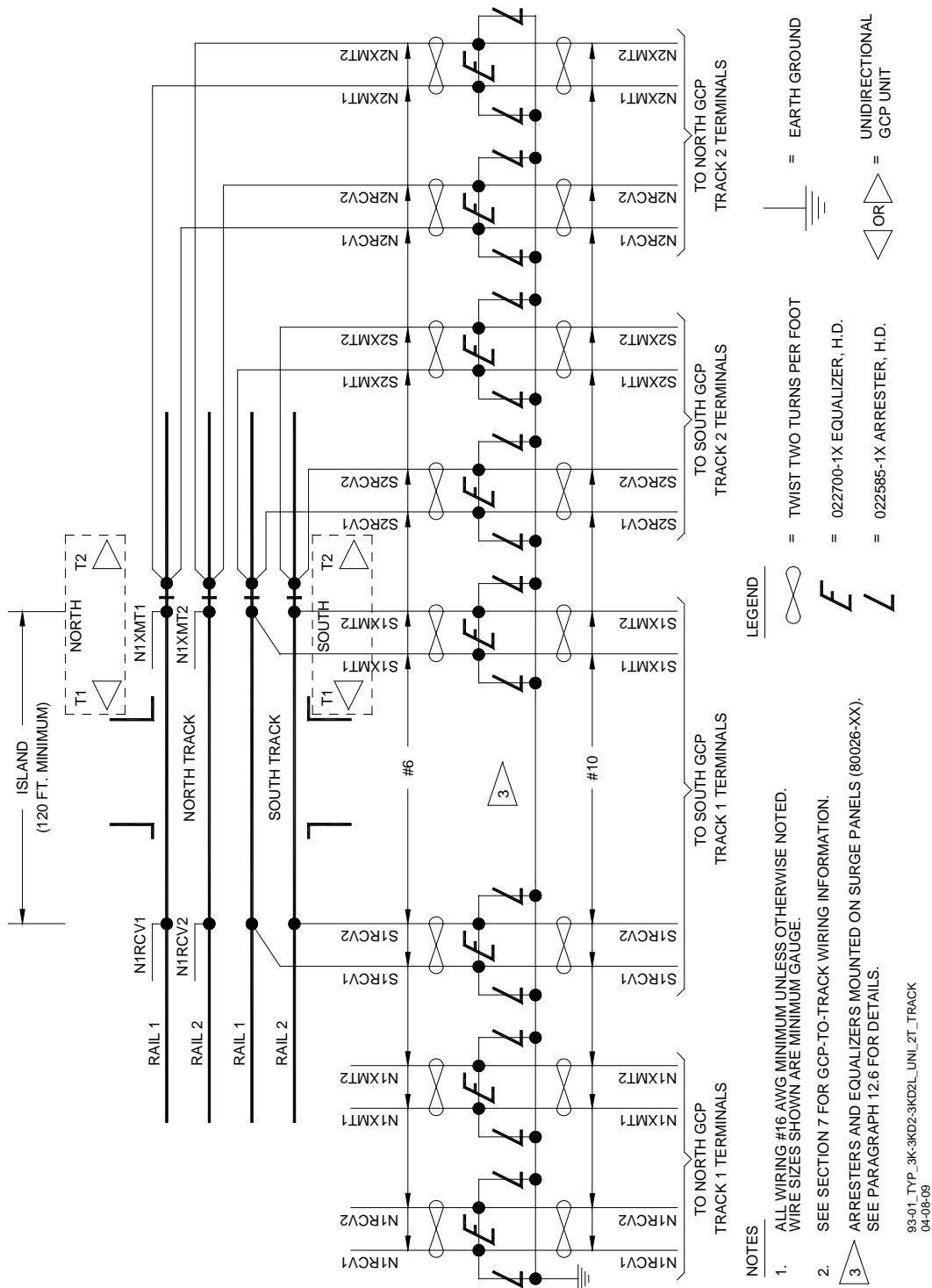


Figure 14-9: Typical Model 3000/3000D2/3000D2L GCP Unidirectional Application, Two Tracks, Back-to-Back, Track Wiring

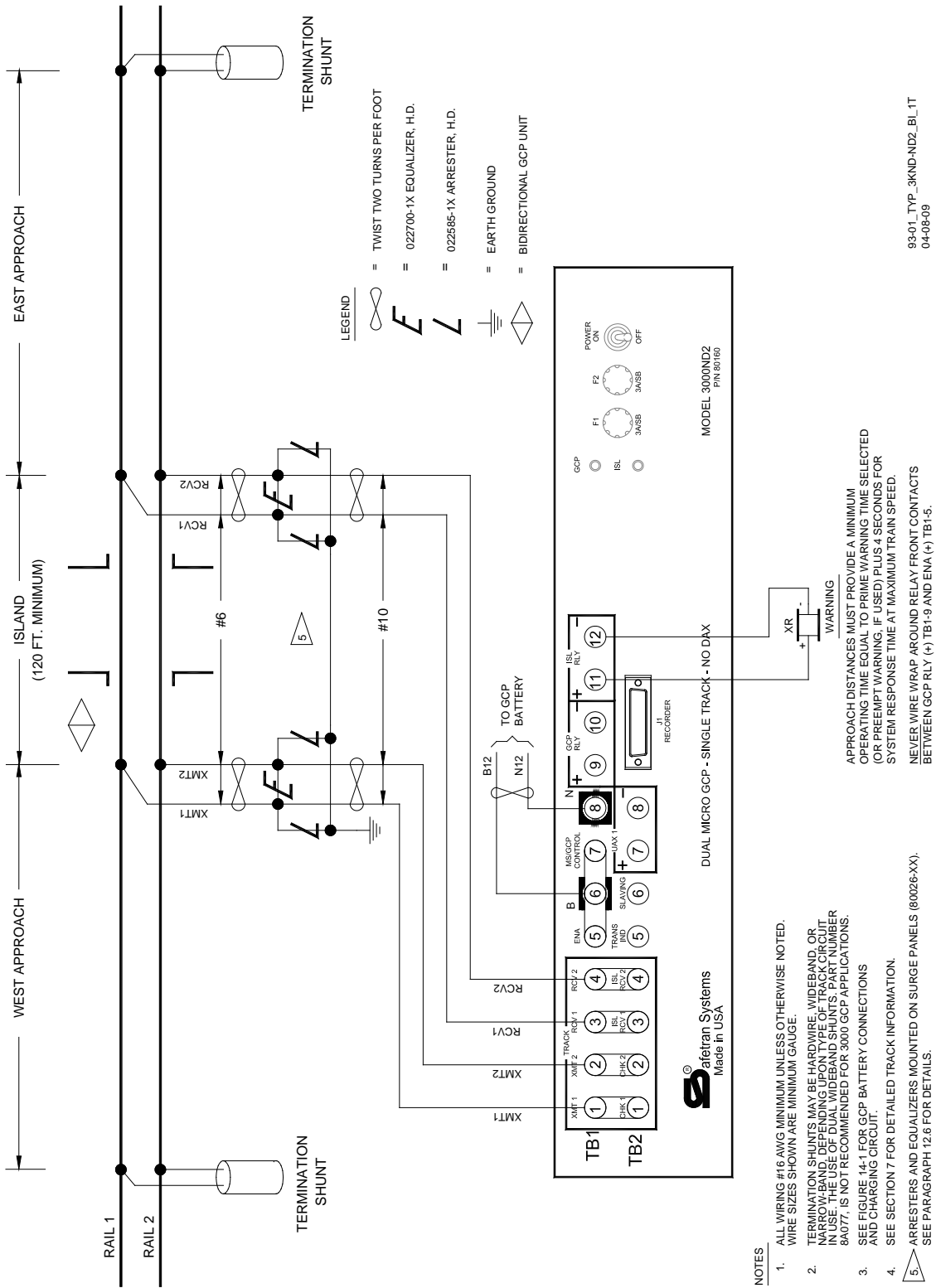


Figure 14-10: Typical Model 3000ND/3000ND2 GCP Bidirectional Application, One Track

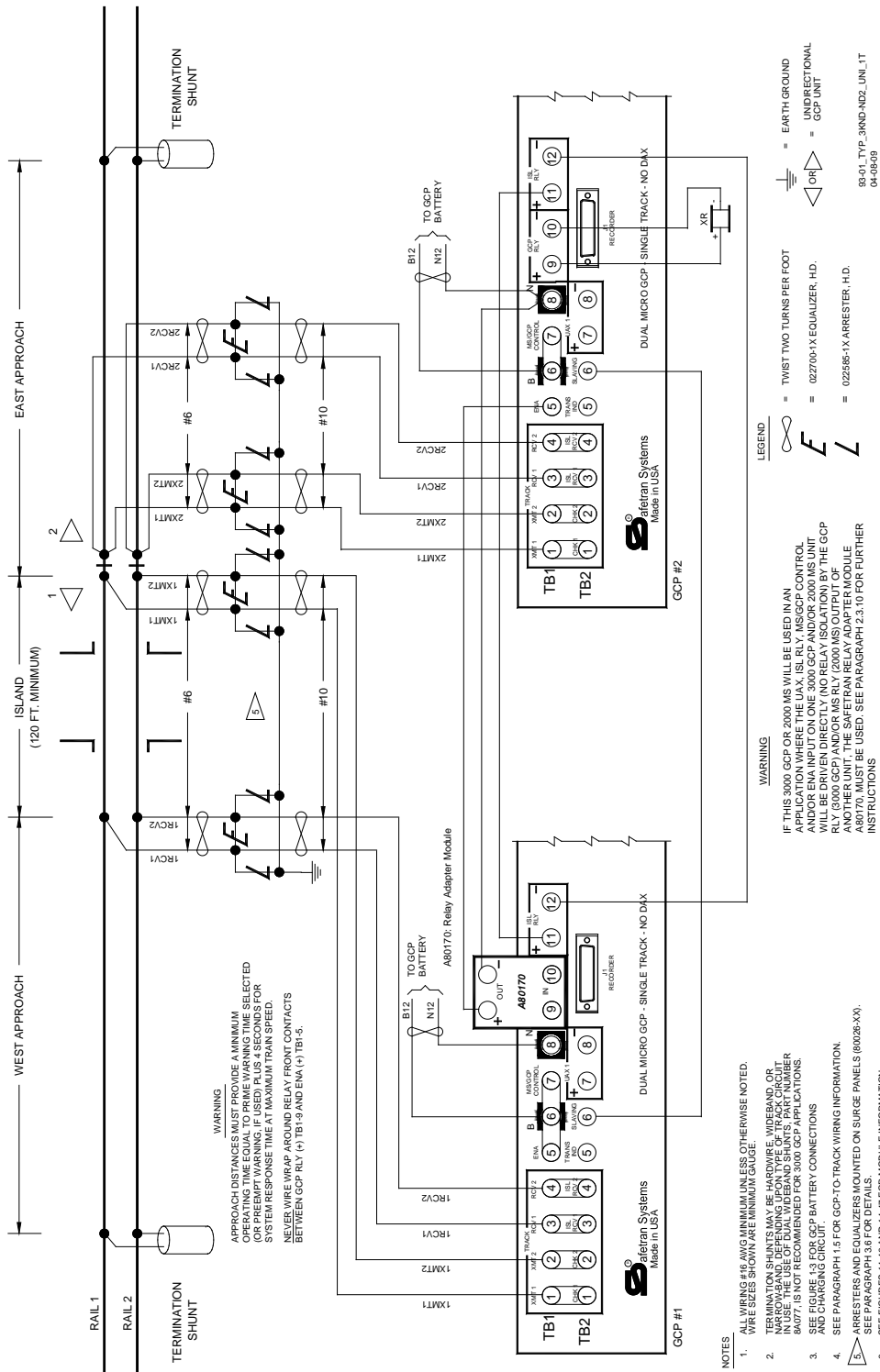


Figure 14-11: Typical Model 3000ND/3000ND2 GCP Unidirectional Application, One Track

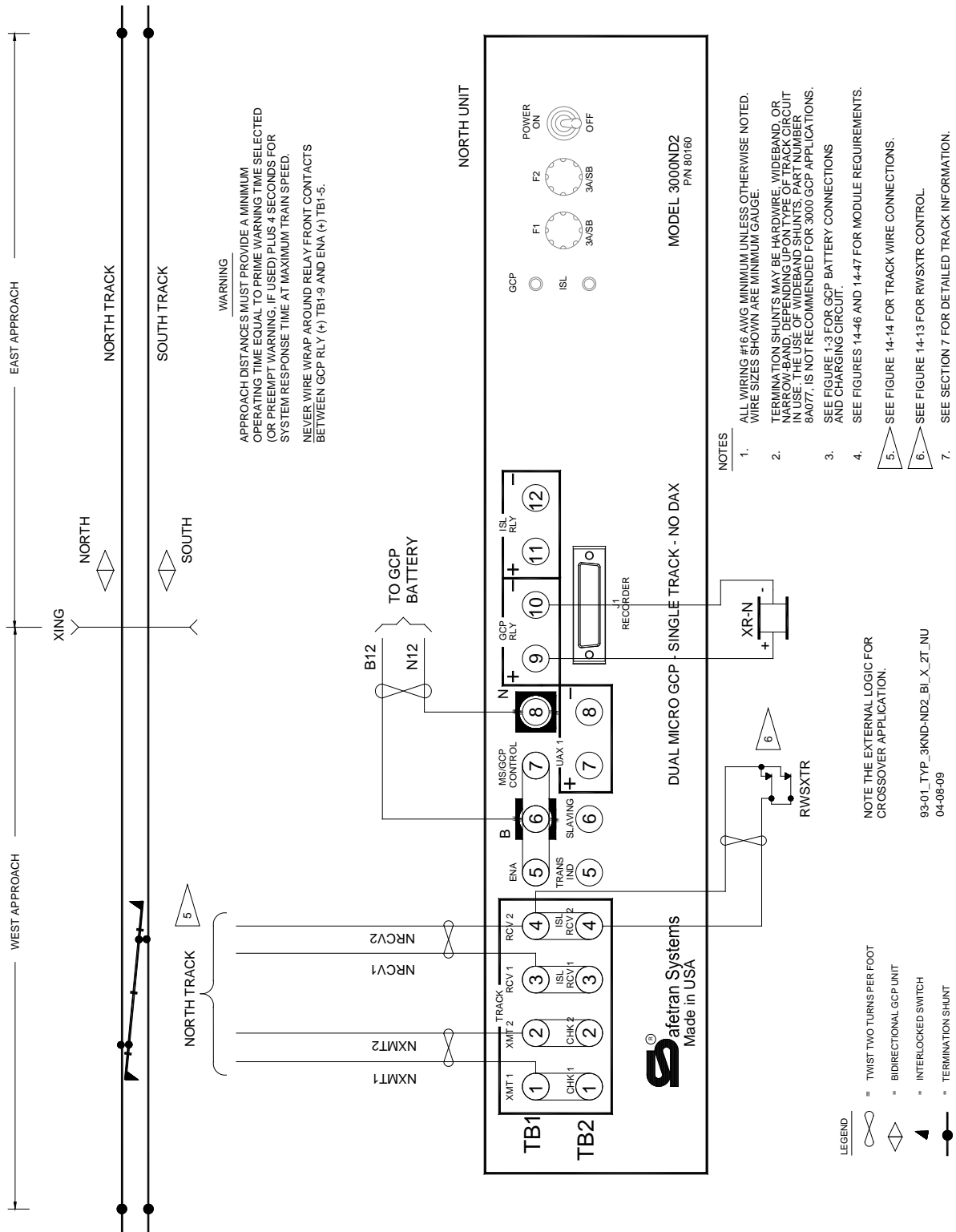


Figure 14-12: Typical Model 3000ND/3000ND2 GCP Bidirectional Application with Crossover in MS/GCP Approach, Two Tracks (with Crossover Relay Logic), North Unit, Case Wiring

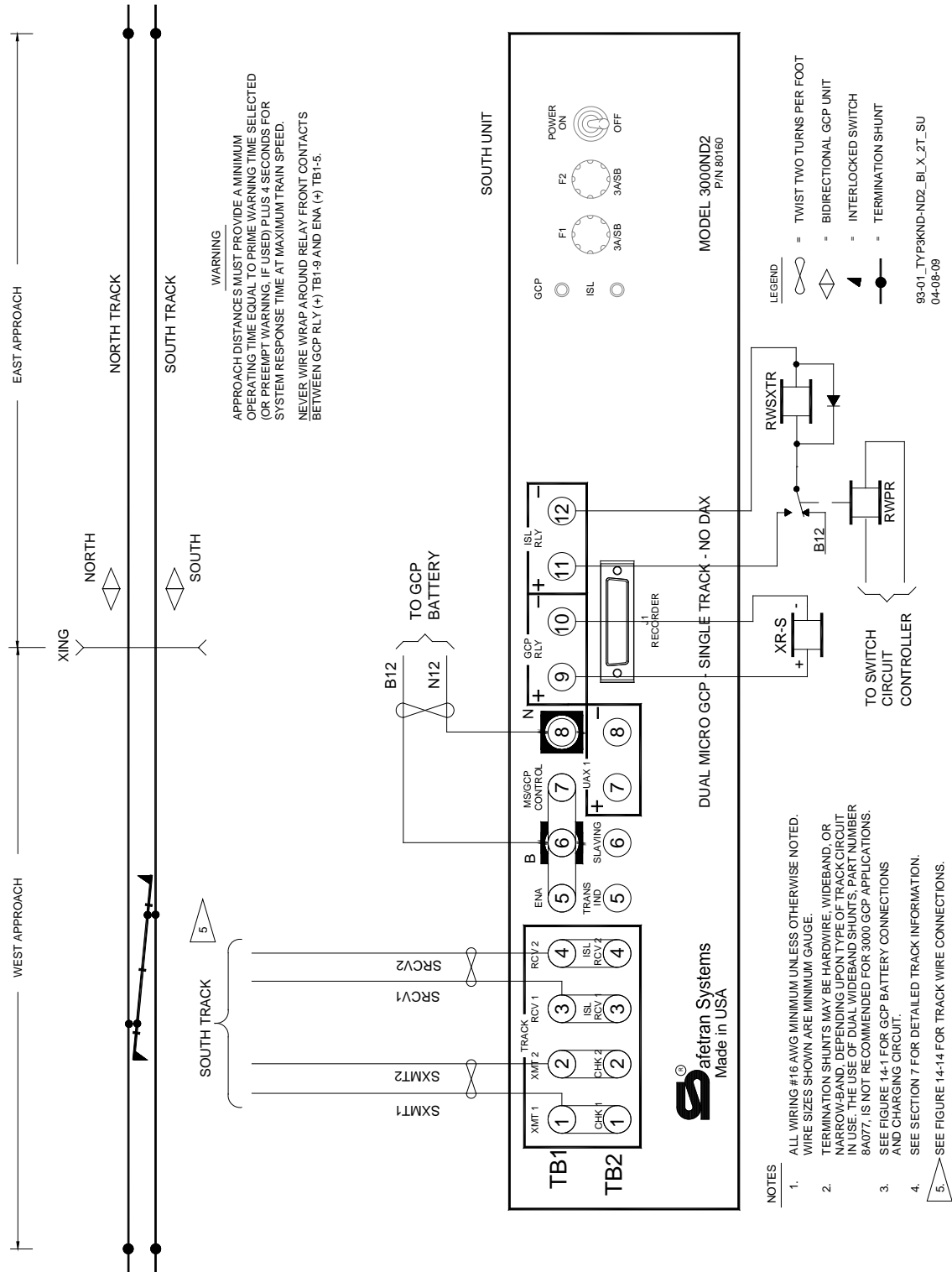
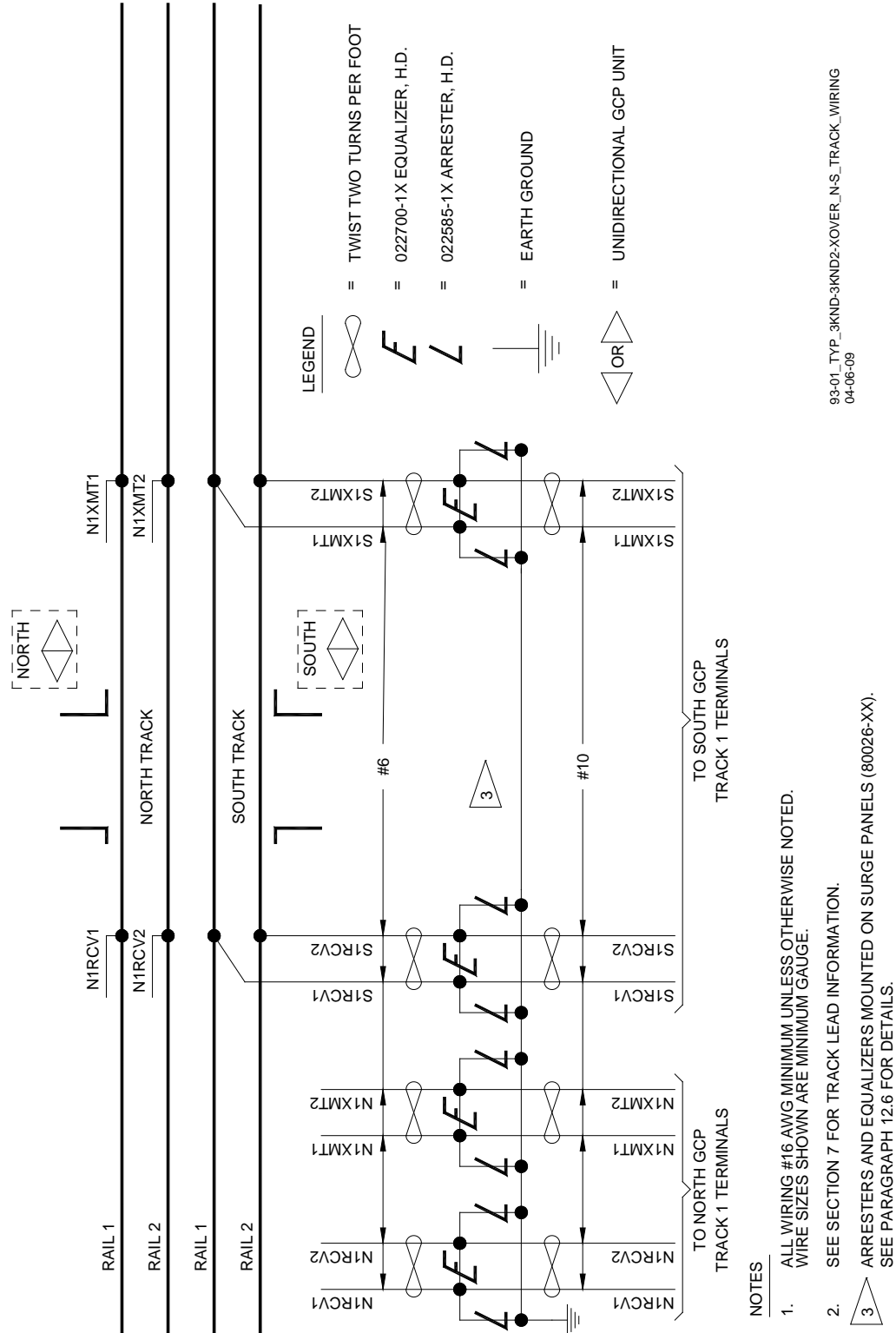


Figure 14-13: Typical Model 3000ND/3000ND2 GCP Bidirectional Application with Crossover in MS/GCP Approach, Two Tracks (with Crossover Relay Logic), South Unit, Case Wiring



93-01_TYP_3KND-3KND2-XOVER_N-S_TRACK_WIRING
04-06-08

Figure 14-14: Typical Model 3000ND/3000ND2 GCP Bidirectional Application with Crossover in MS/GCP Approach, Two Tracks (with Crossover Relay Logic), North or South Units, Track Wiring

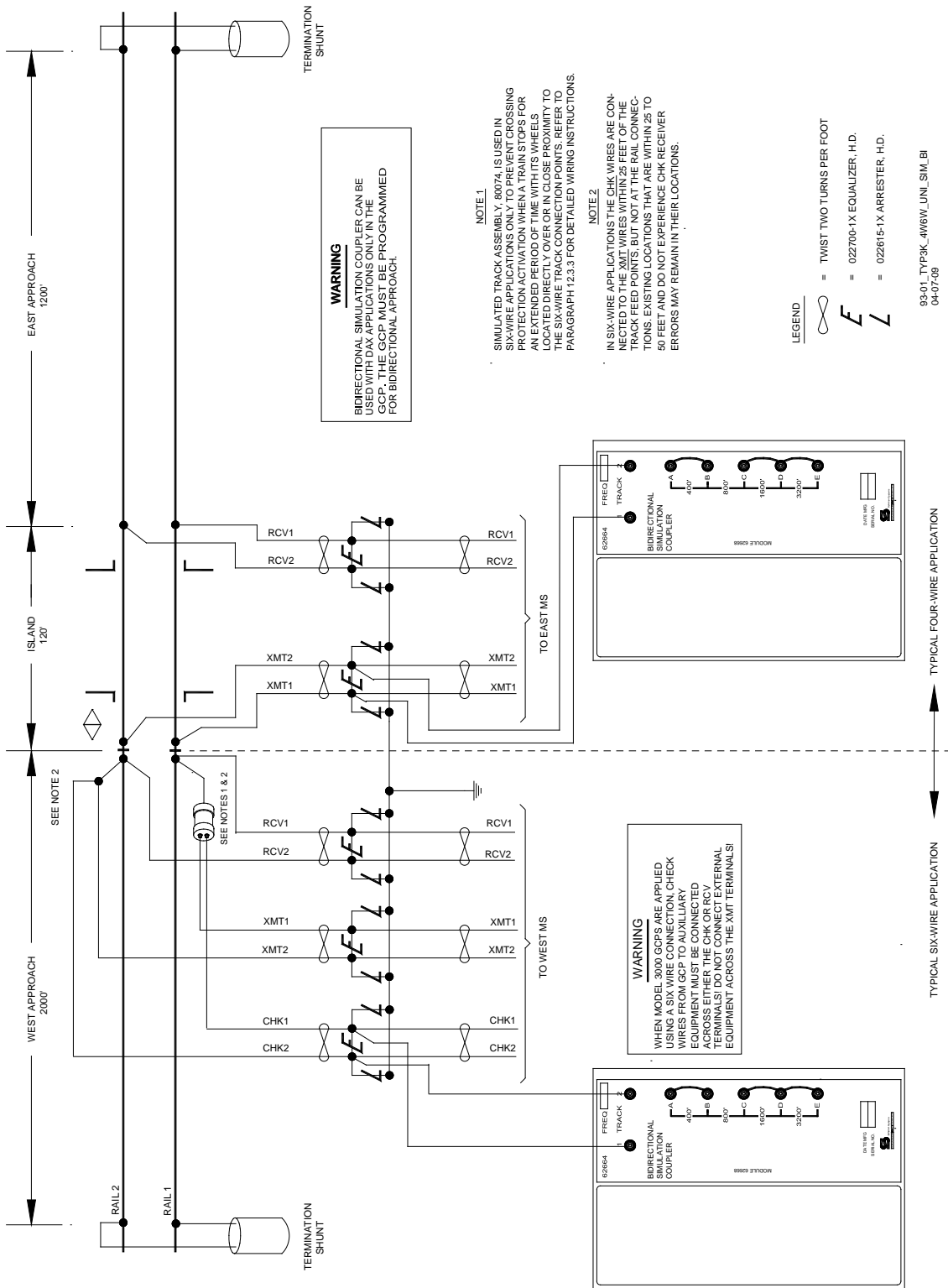


Figure 14-15: Proper Model 3000 GCP Four-Wire and Six-Wire Connections Using Auxiliary Track Circuit Equipment on 3000 GCP Operating in the Bidirectional Simulation Mode

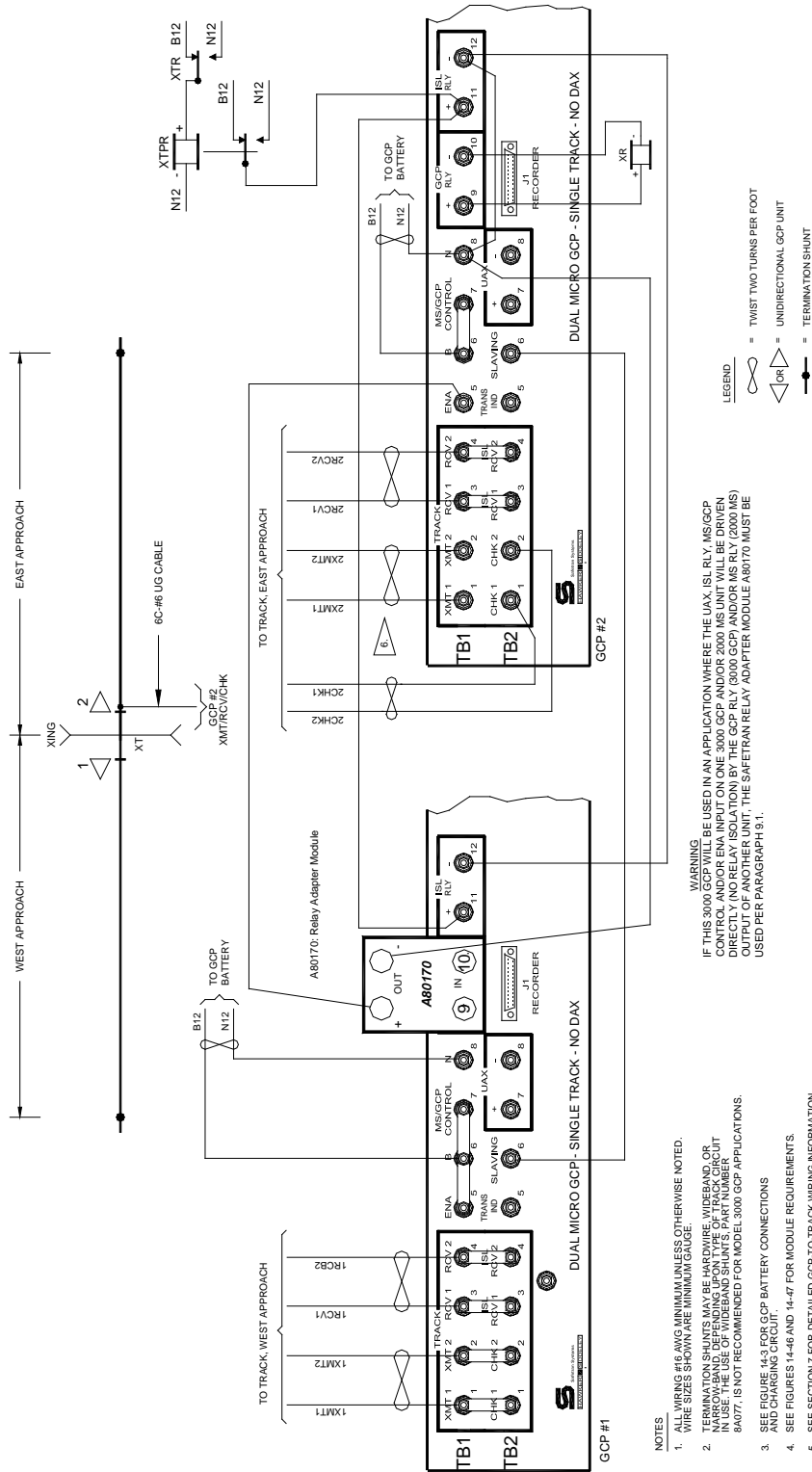


Figure 14-16: Typical Model 3000ND2 GCP Unidirectional Application with DC Island Track Circuit, One Track, Six Wire Hookup, Case Wiring

WARNING
IF THIS 3000 GCP WILL BE USED IN AN APPLICATION WHERE THE UAX, ISL RLY, MS/GCP CONTROL, AND/OR ENA INPUT ON ONE 3000 GCP AND/OR 2000 MS UNIT WILL BE DRIVEN DIRECTLY (NO RELAY ISOLATION) BY THE GCP RLY (3000 GCP) AND/OR MS RLY (2000 MS) OUTPUT OF ANOTHER UNIT, THE SWETRAN RELAY ADAPTER MODULE A80170 MUST BE USED PER PARAGRAPH 3.1.

- NOTES**
1. ALL WIRING #16 AWG MINIMUM UNLESS OTHERWISE NOTED.
 2. WIRE SIZES SHOWN ARE MINIMUM GAUGE.
 3. TERMINATION SHUNTS MAY BE HARDWIRE, WIDEBAND, OR WIREBAND. THE WIREBAND SHUNT IS RECOMMENDED FOR USE IN THE USE OF WIREBAND SHUNTS. PART NUMBER 8A077, IS NOT RECOMMENDED FOR MODEL 3000 GCP APPLICATIONS.
 4. SEE FIGURES 14-46 AND 14-47 FOR MODULE REQUIREMENTS.
 5. SEE SECTION 7 FOR DETAILED GCP-TO-TRACK WIRING INFORMATION.
 6. SIX-WIRE CONFIGURATION SHOWN IS RECOMMENDED WHEN TRANSMIT WIRE LENGTH EXCEEDS MAXIMUM LENGTHS SPECIFIED IN SECTION VII OF THIS MANUAL. WHEN USING SIX-WIRE WIRING, WIREBAND SHUNTS MUST BE REMOVED BETWEEN TB1-1 AND TB1-2 AND BETWEEN TB2-1 AND TB2-2 AS SHOWN.

- LEGEND**
- ∞ = TWIST TWO TURNS PER FOOT
 - ◁ ▷ = UNIDIRECTIONAL GCP UNIT
 - |— = TERMINATION SHUNT
- 93-01_3KWD-ND2_UNI_DC_ISL_TC_1T_6WIRE_CASE
04-08-09

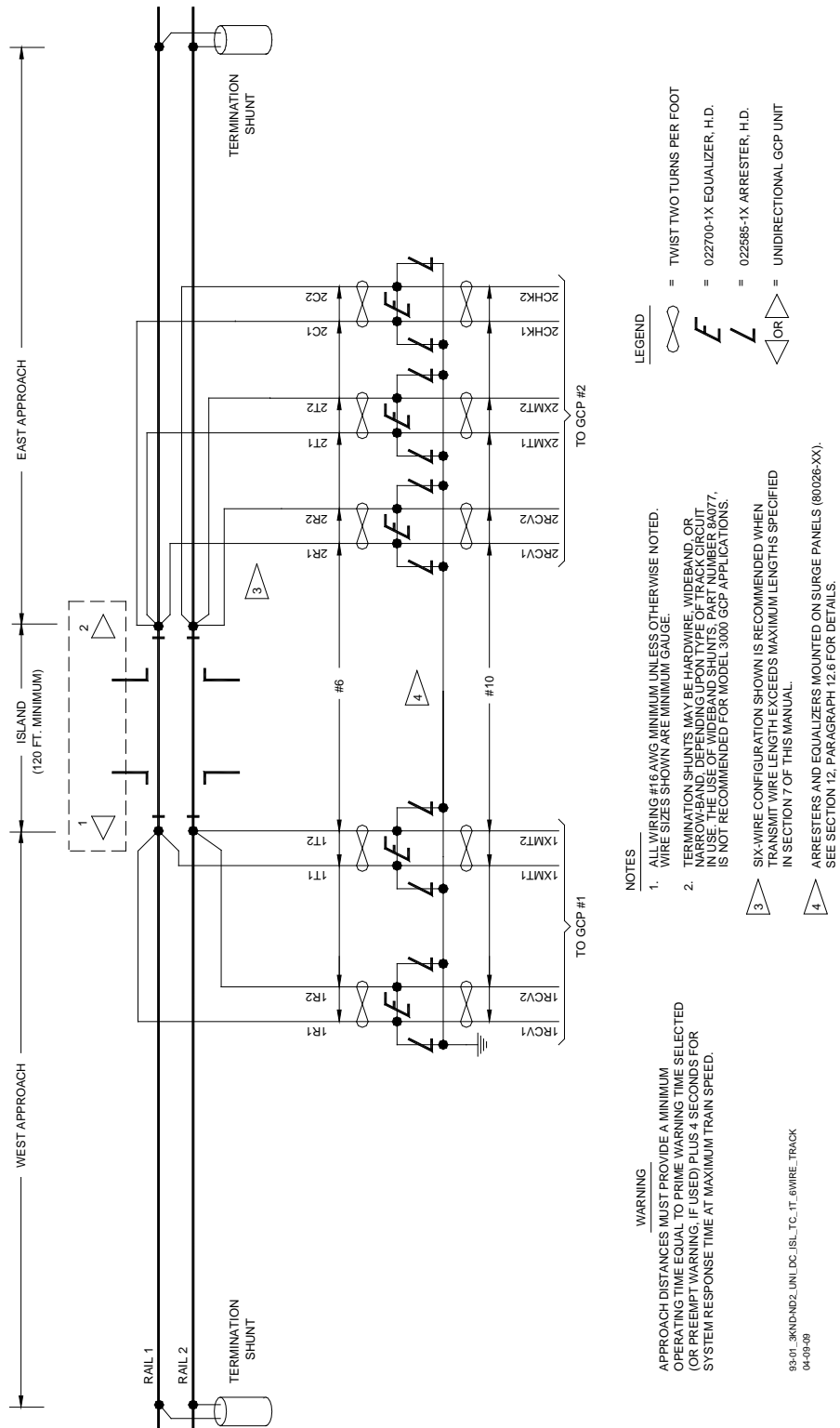
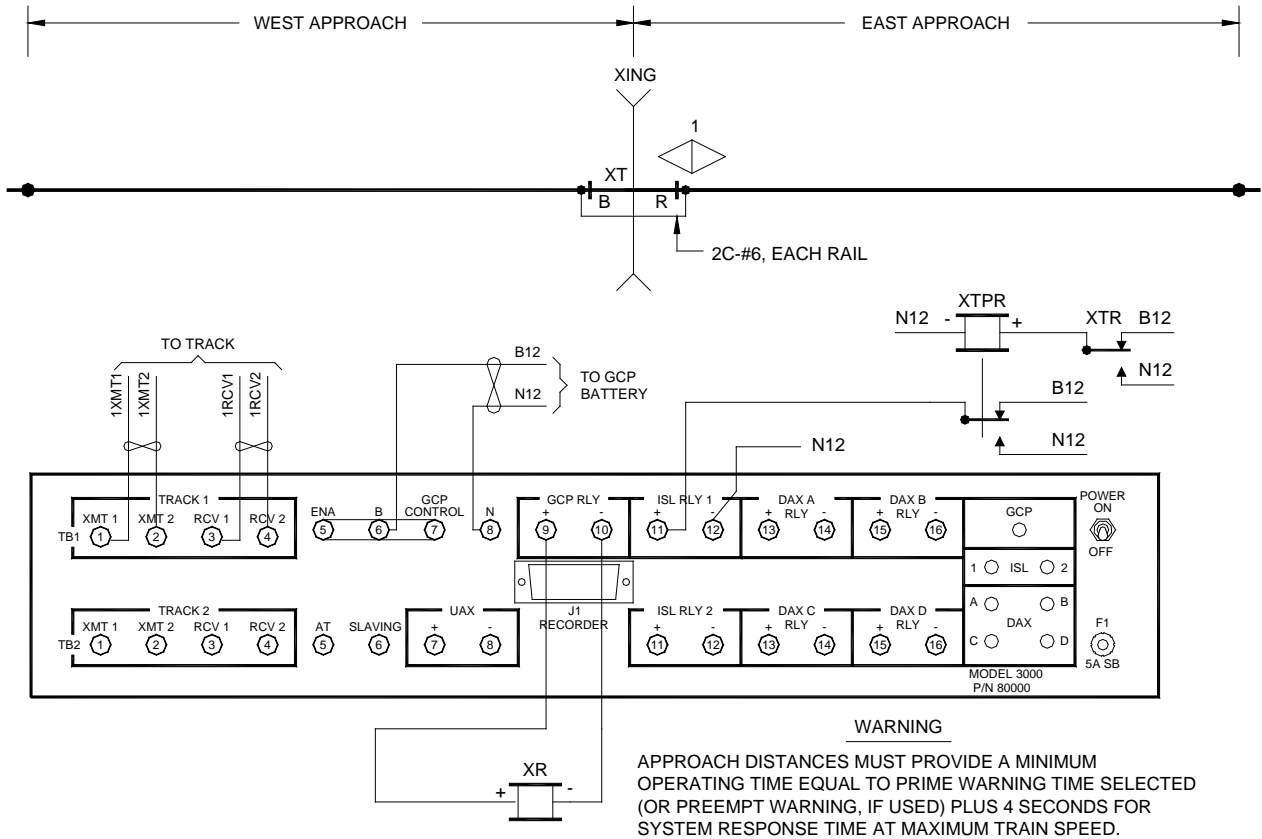


Figure 14-17: Typical Model 3000ND2 GCP Unidirectional Application with DC Island Track Circuit, One Track, Six Wire Hookup, Track Wiring



NOTES

1. ALL WIRING #16 AWG MINIMUM UNLESS OTHERWISE NOTED. WIRE SIZES SHOWN ARE MINIMUM GAUGE.
2. TERMINATION SHUNTS MAY BE HARDWIRE, WIDEBAND, OR NARROW-BAND, DEPENDING UPON TYPE OF TRACK CIRCUIT IN USE. THE USE OF WIDEBAND SHUNTS, PART NUMBER 8A077, IS NOT RECOMMENDED IN MODEL 3000 GCP APPLICATIONS.
3. SEE FIGURE 14-19 FOR GCP-TO-TRACK WIRING.
4. SEE FIGURE 14-1 FOR GCP BATTERY CONNECTIONS AND CHARGING CIRCUIT.
5. SEE FIGURES 14-44 AND 14-45 FOR MODULE REQUIREMENTS.

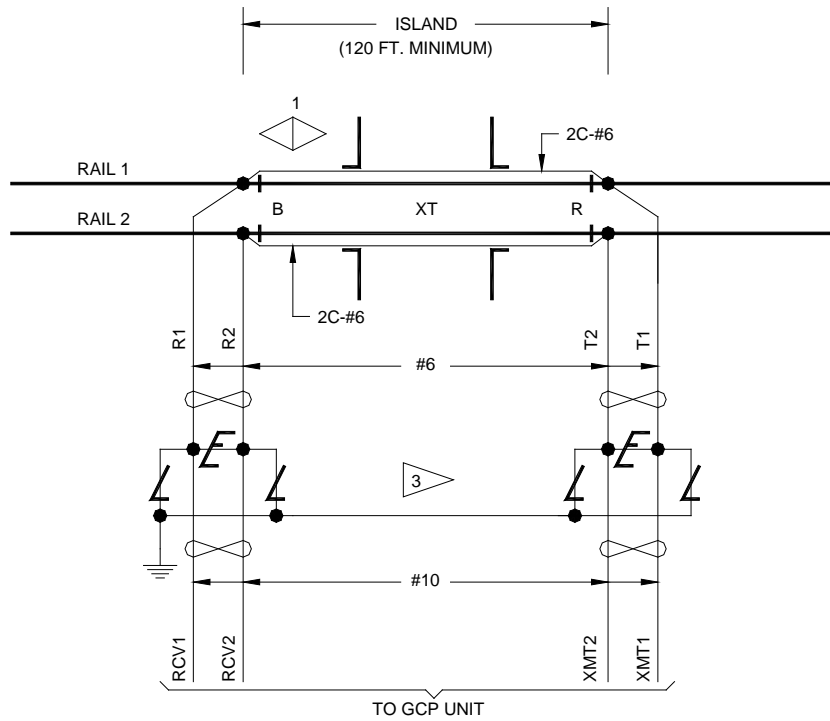
93-01_TYP_3K-3KD2_BI_DC_ISL_TC_1T_6-WIRE_CASE
04-09-09

LEGEND

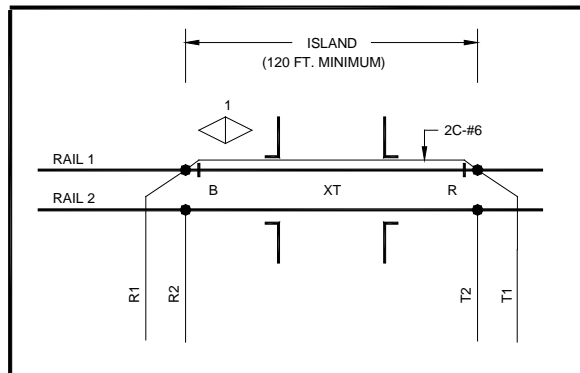
- = TWIST TWO TURNS PER FOOT
- = BIDIRECTIONAL GCP UNIT
- = UNIDIRECTIONAL GCP UNIT
- = TERMINATION SHUNT
- Mf = MOTION FREQUENCY

Figure 14-18: Typical Model 3000/3000D2 GCP Bidirectional Application with DC Island Track Circuit, One Track, Case Wiring

MODEL 3000 GCP APPLICATION DIAGRAMS



OPTIONAL INSTALLATION:
INSULATED JOINTS IN ONE RAIL ONLY - SINGLE JUMPER INSTALLED.



NOTES

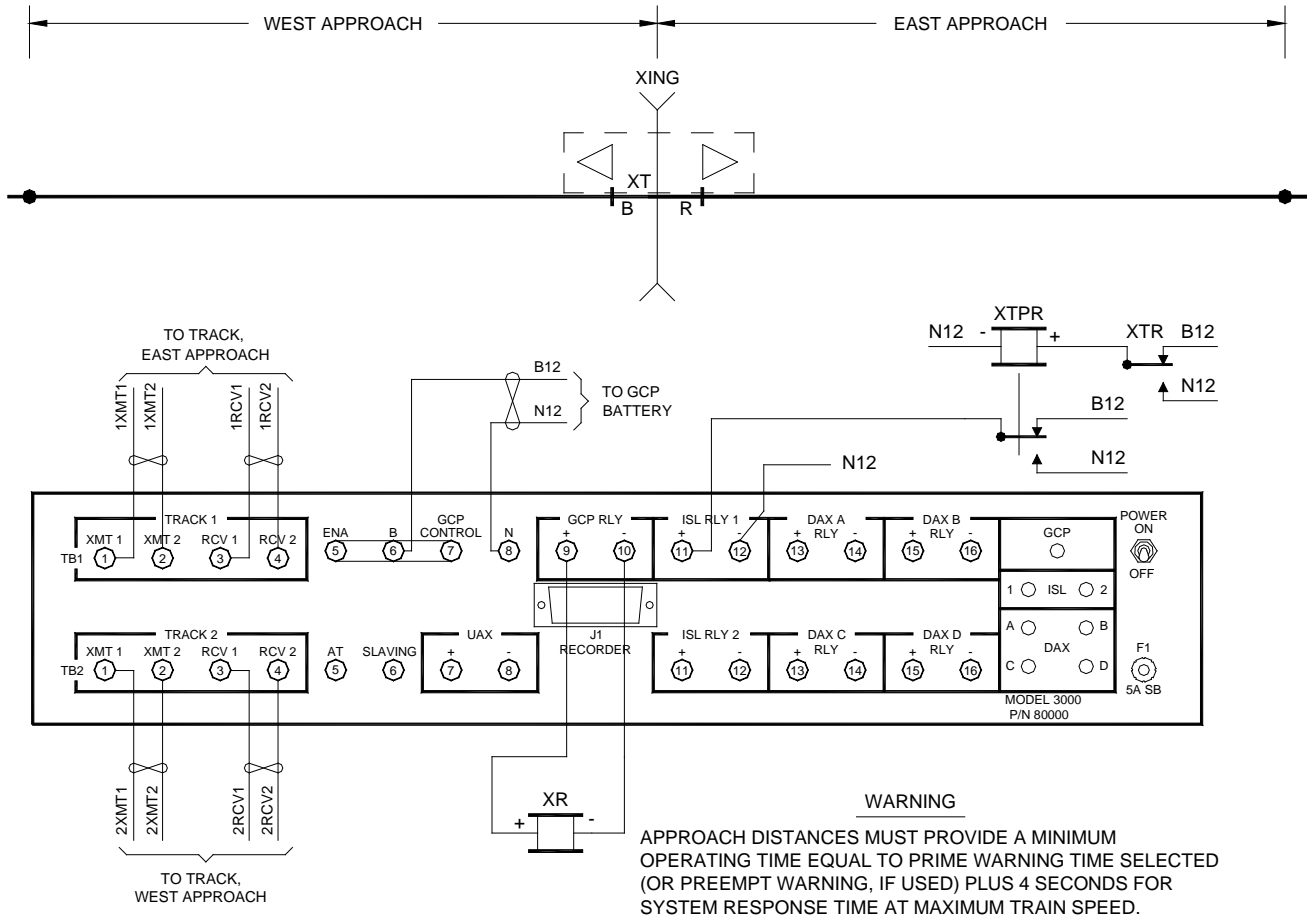
1. WIRE SIZES SHOWN ARE MINIMUM GAUGE.
2. SEE SECTION 7 FOR DETAILED GCP-TO-TRACK WIRING INFORMATION.
3. ARRESTERS AND EQUALIZERS MOUNTED ON SURGE PANELS (80026-XX). SEE PARAGRAPH 12.6 FOR DETAILS.

93-01_TYP_3K-3KD2_BI_DC_ISL_TC_1T_6-WIRE_TRACK
04-09-09

LEGEND

- = TWIST TWO TURNS PER FOOT
- = 022700-1X EQUALIZER, H.D.
- = 022585-1X ARRESTER, H.D.
- = BIDIRECTIONAL MS/GCP UNIT




Figure 14-19: Typical Model 3000/3000D2 GCP Bidirectional Application with DC Island Track Circuit, One Track, Track Wiring



NOTES

1. ALL WIRING #16 AWG MINIMUM UNLESS OTHERWISE NOTED. WIRE SIZES SHOWN ARE MINIMUM GAUGE.
2. TERMINATION SHUNTS MAY BE HARDWIRE, WIDEBAND, OR NARROW-BAND, DEPENDING UPON TYPE OF TRACK CIRCUIT IN USE. THE USE OF DUAL WIDE BAND SHUNTS, PART NUMBER 8A077, IS NOT RECOMMENDED FOR MODEL 3000 GCP USE.
3. SEE FIGURE 14-21 FOR GCP-TO-TRACK WIRING.
4. SEE FIGURE 14-1 FOR GCP BATTERY CONNECTIONS AND CHARGING CIRCUIT.
5. SEE FIGURES 14-44 AND 14-45 FOR MODULE REQUIREMENTS.

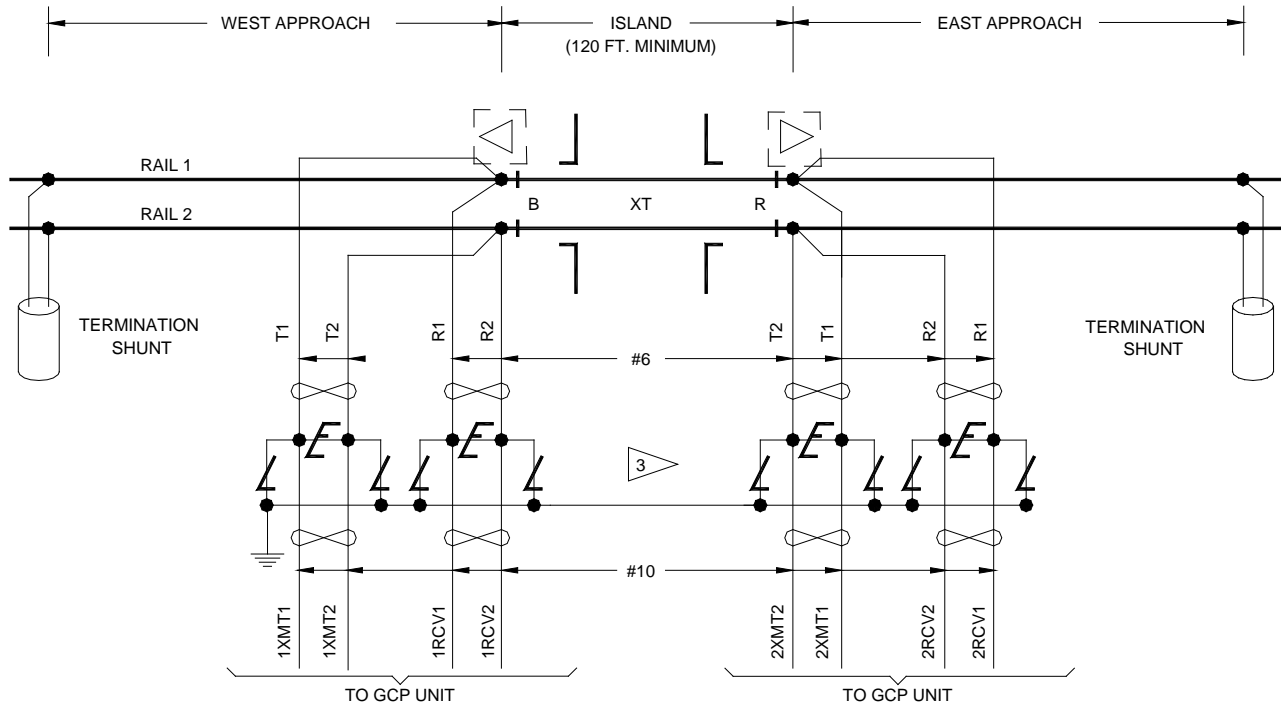
LEGEND

-  = TWIST TWO TURNS PER FOOT
-  = UNIDIRECTIONAL GCP UNIT
-  = TERMINATION SHUNT

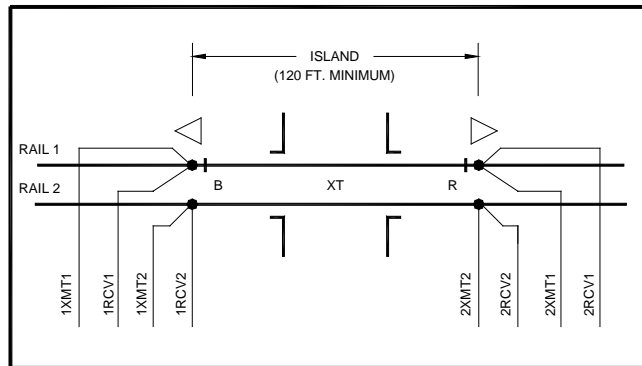
93-01_TYP_3K_3KD2_UNI_DC_ISL_TC_1T_6-WIRE_CASE
04-03-09

Figure 14-20: Typical Model 3000/3000D2 GCP Unidirectional Application with DC Island Track Circuit, One Track, Case Wiring

MODEL 3000 GCP APPLICATION DIAGRAMS



OPTIONAL INSTALLATION:
INSULATED JOINTS IN ONE
RAIL ONLY.



NOTES

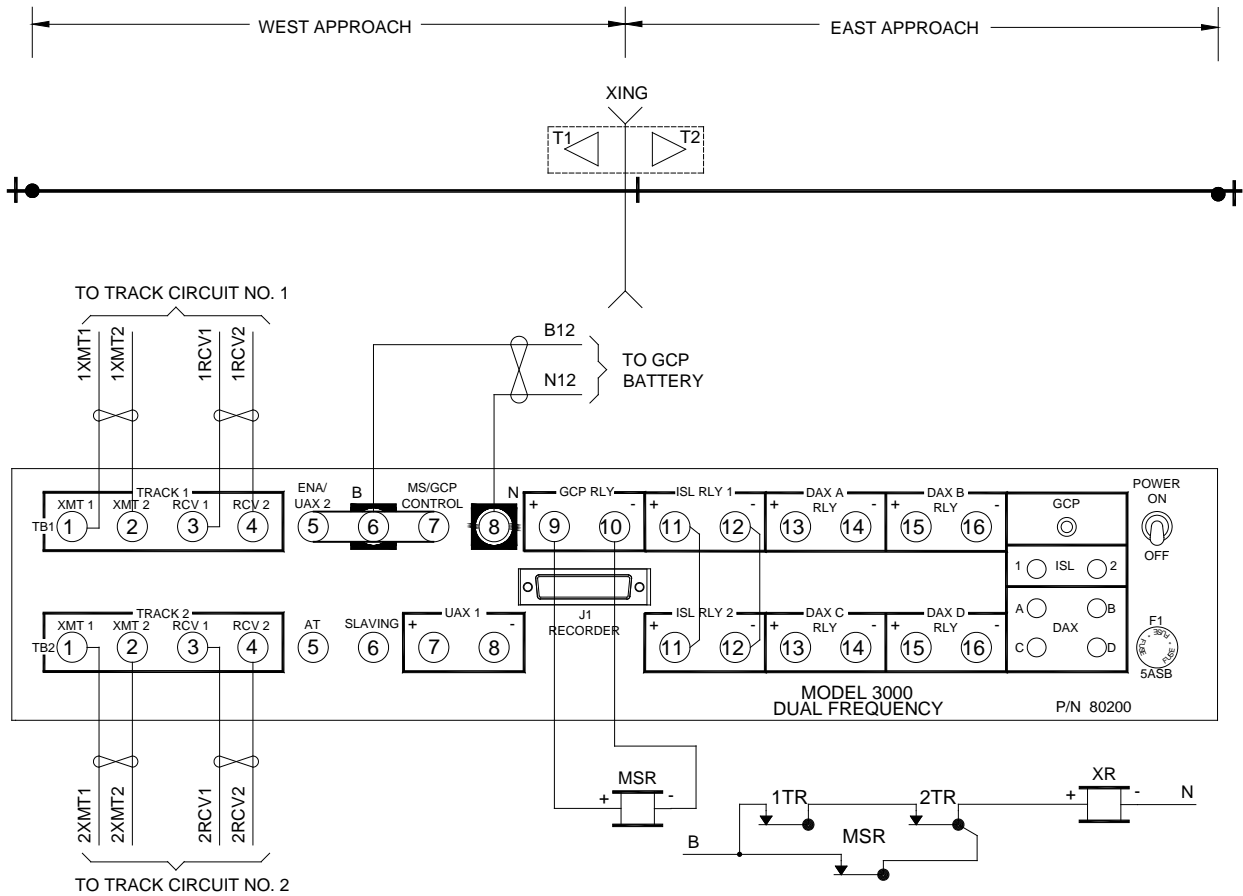
1. WIRE SIZES SHOWN ARE MINIMUM GAUGE.
2. SEE SECTION 7 FOR DETAILED GCP-TO-TRACK WIRING INFORMATION.
3. ARRESTERS AND EQUALIZERS MOUNTED ON SURGE PANELS (80026-XX). SEE PARAGRAPH 12.6 FOR DETAILS.

93-01_TYP_3K_3KD2_UNI_APP_DC_ISL_TC_1T_6-WIRE_TRACK
04-09-09

LEGEND

- = TWIST TWO TURNS PER FOOT
- = 022700-1X EQUALIZER, H.D.
- = 022585-1X ARRESTER, H.D.
- = UNIDIRECTIONAL GCP UNIT

Figure 14-21: Typical Model 3000/3000D2 GCP Unidirectional Application with DC Island Track Circuit, One Track, Track Wiring



NOTES

1. ALL WIRING #16 AWG MINIMUM UNLESS OTHERWISE NOTED. WIRE SIZES SHOWN ARE MINIMUM GAUGE.
2. SEE FIGURE 14-23 FOR GCP-TO-TRACK WIRING.
3. SEE FIGURE 14-1 FOR GCP BATTERY CONNECTIONS AND CHARGING CIRCUIT.
4. USE FREQUENCY 790 HZ AND HIGHER.
5. SEE FIGURES 14-44 AND 14-45 FOR MODULE REQUIREMENTS.

WARNING

APPROACH DISTANCES MUST PROVIDE A MINIMUM OPERATING TIME EQUAL TO PRIME WARNING TIME SELECTED (OR PREEMPT WARNING, IF USED) PLUS 4 SECONDS FOR SYSTEM RESPONSE TIME AT MAXIMUM TRAIN SPEED.

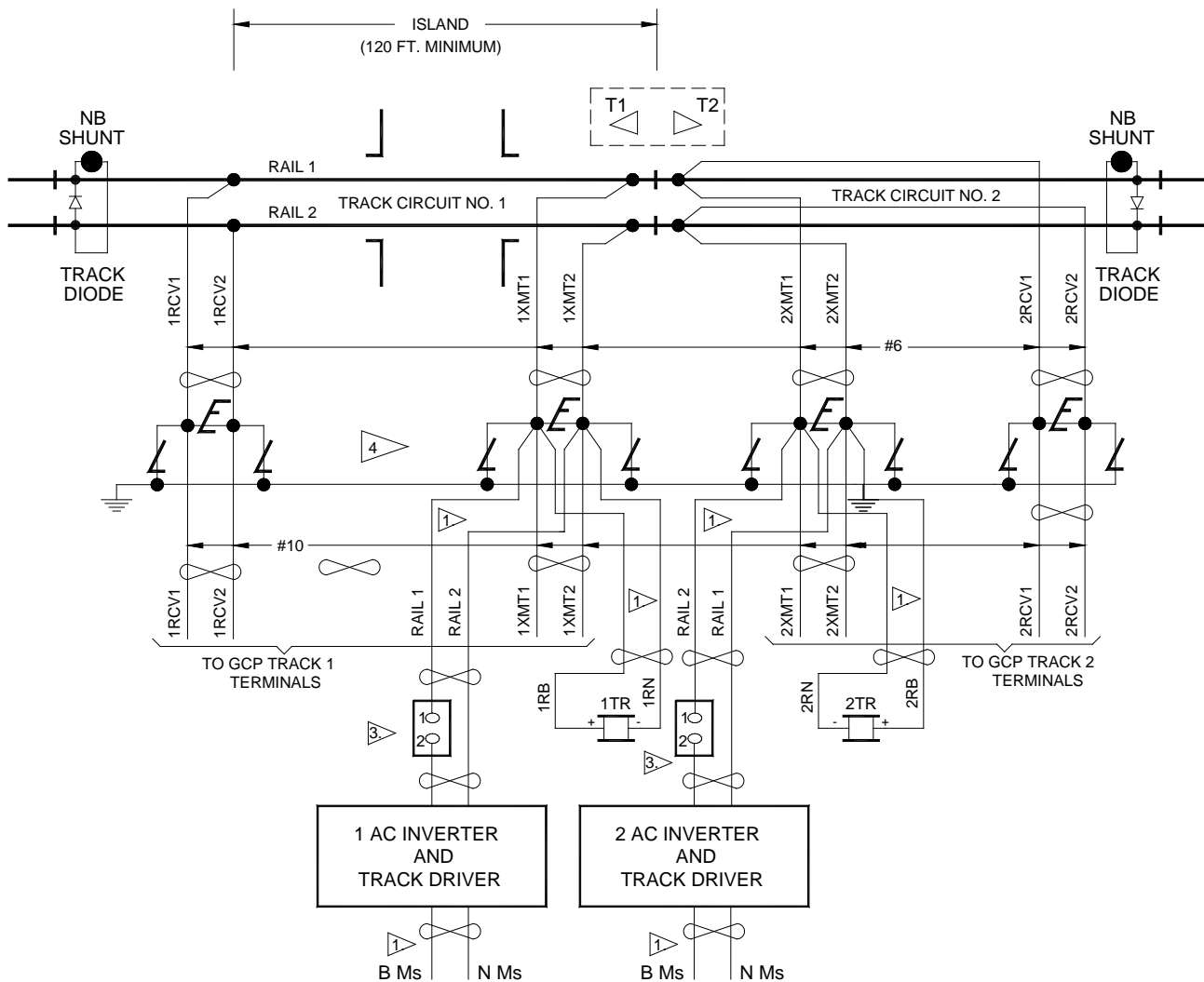
NEVER WIRE WRAP AROUND RELAY FRONT CONTACTS BETWEEN GCP RLY (+) TB1-9 AND ENA (+) TB1-5.

LEGEND

- = TWIST TWO TURNS PER FOOT
- OR = UNIDIRECTIONAL GCP UNIT
- = NARROW-BAND TERMINATION SHUNT

93-01_TYP_3K-3KD2_MS_STYL_C_CASE
04-09-09

Figure 14-22: Typical Model 3000/3000D2 GCP Motion Sensor Application plus Track Wraps of MSR with Style 'C' Track Circuit, One Track, Case Wiring



NOTES

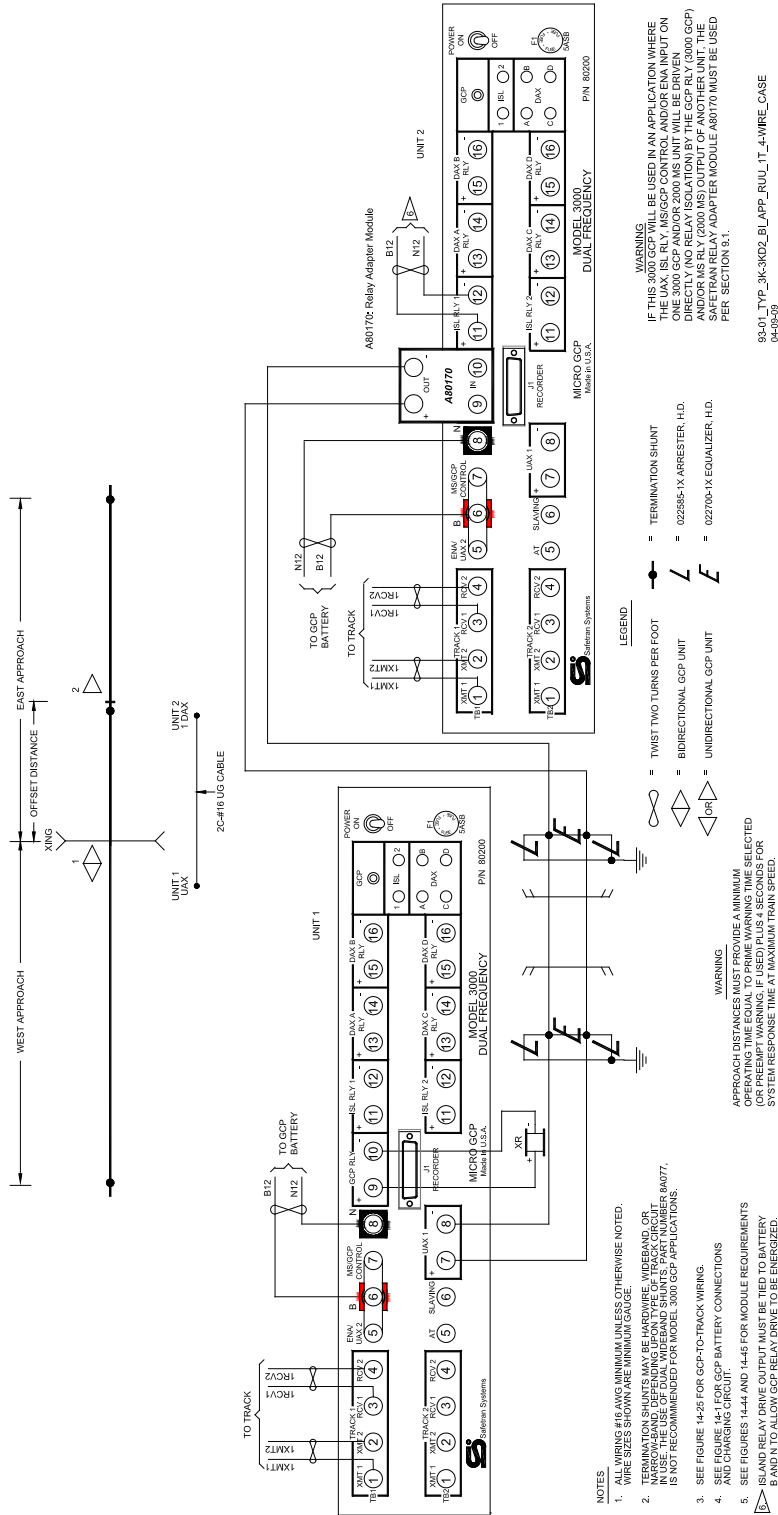
1. WIRE SIZE AND CIRCUIT DESIGN PER MANUFACTURER'S RECOMMENDATIONS.
2. SEE SECTION 7 FOR GCP-TO-TRACK WIRING INFORMATION.
3. 8A466-3 ISOLATION FILTER IS USED FOR 60 HZ APPLICATION AND THE 8A471-180 ISOLATION FILTER FOR THE 180 HZ APPLICATION.
4. ARRESTERS AND EQUALIZERS MOUNTED ON SURGE PANELS (80026-XX). SEE PARAGRAPH 12.6 FOR DETAILS.

93-01_TYP_3K-3KD2_MS_STYL_C_TRACK
04-09-09

LEGEND

- = TWIST TWO TURNS PER FOOT
- = 022700-1X EQUALIZER, H.D.
- = 022585-1X ARRESTOR, H.D.
- OR = UNIDIRECTIONAL GCP UNIT
- = EARTH GROUND

Figure 14-23: Typical Model 3000/3000D2 GCP Motion Sensor Application plus Track Wraps of MSR with Style 'C' Track Circuit, One Track, Track Wiring



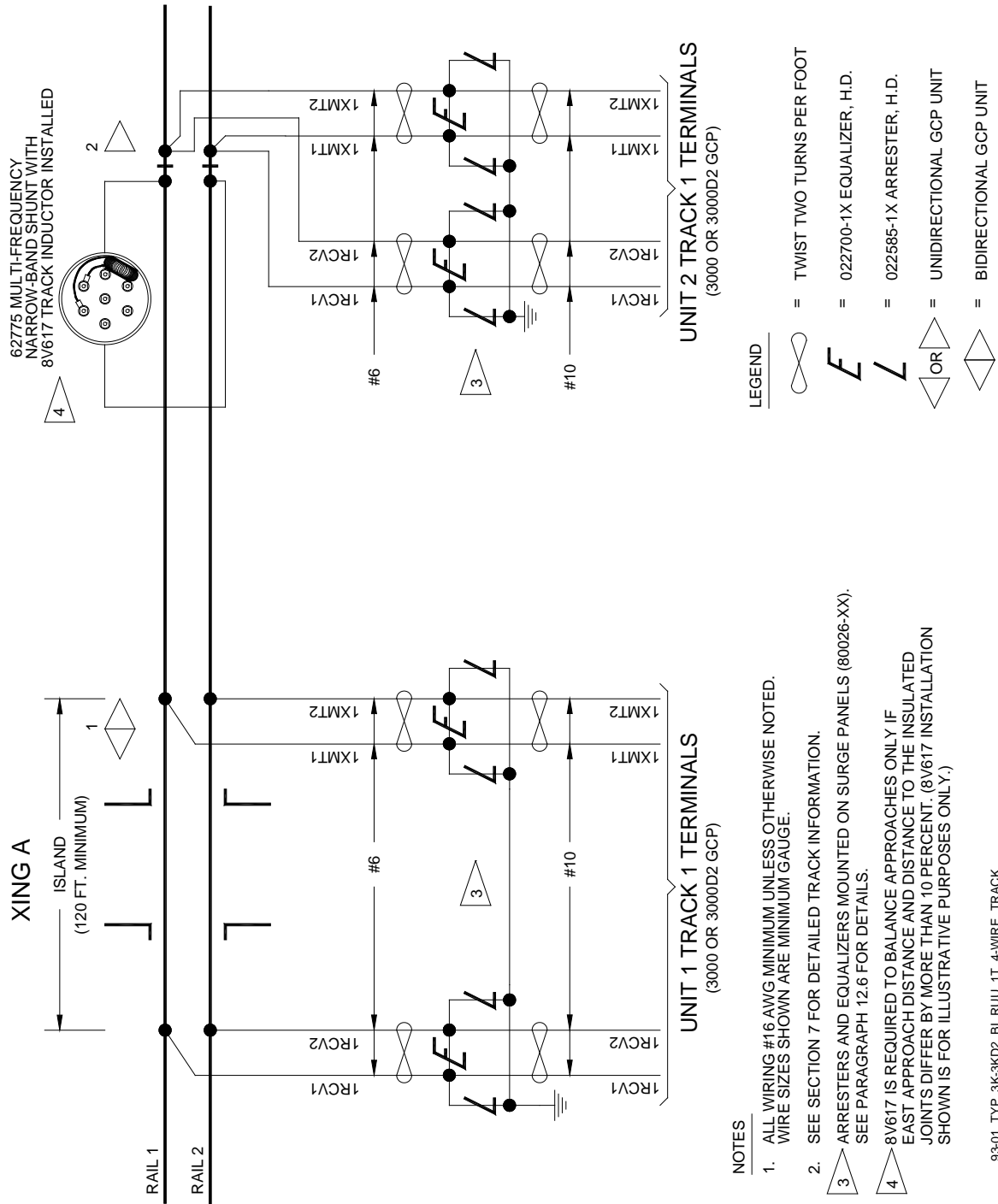


Figure 14-25: Typical Model 3000/3000D2 GCP Bidirectional Application with Remote Unidirectional Unit, One Track (Four-Wire), Track Wiring

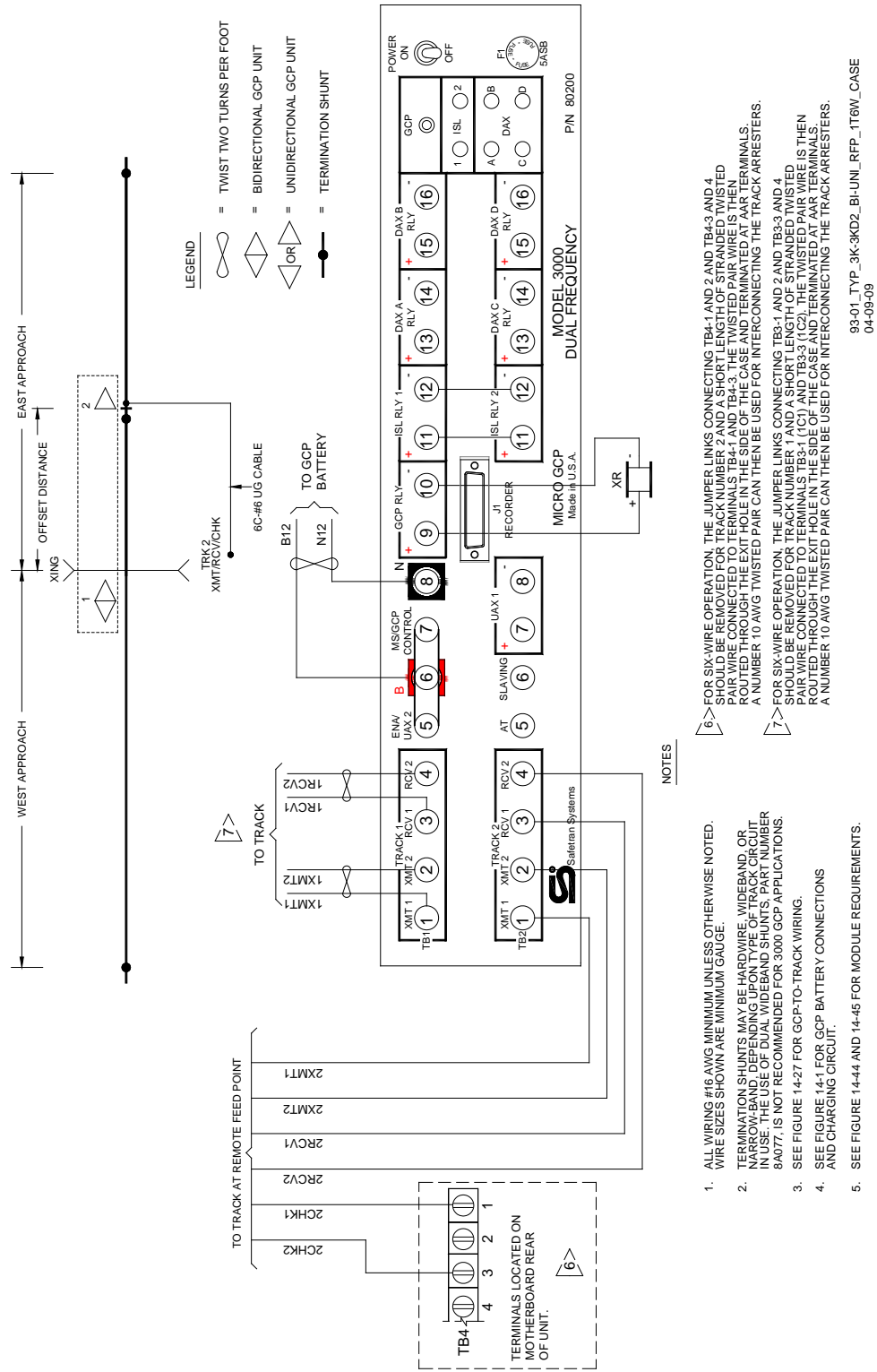
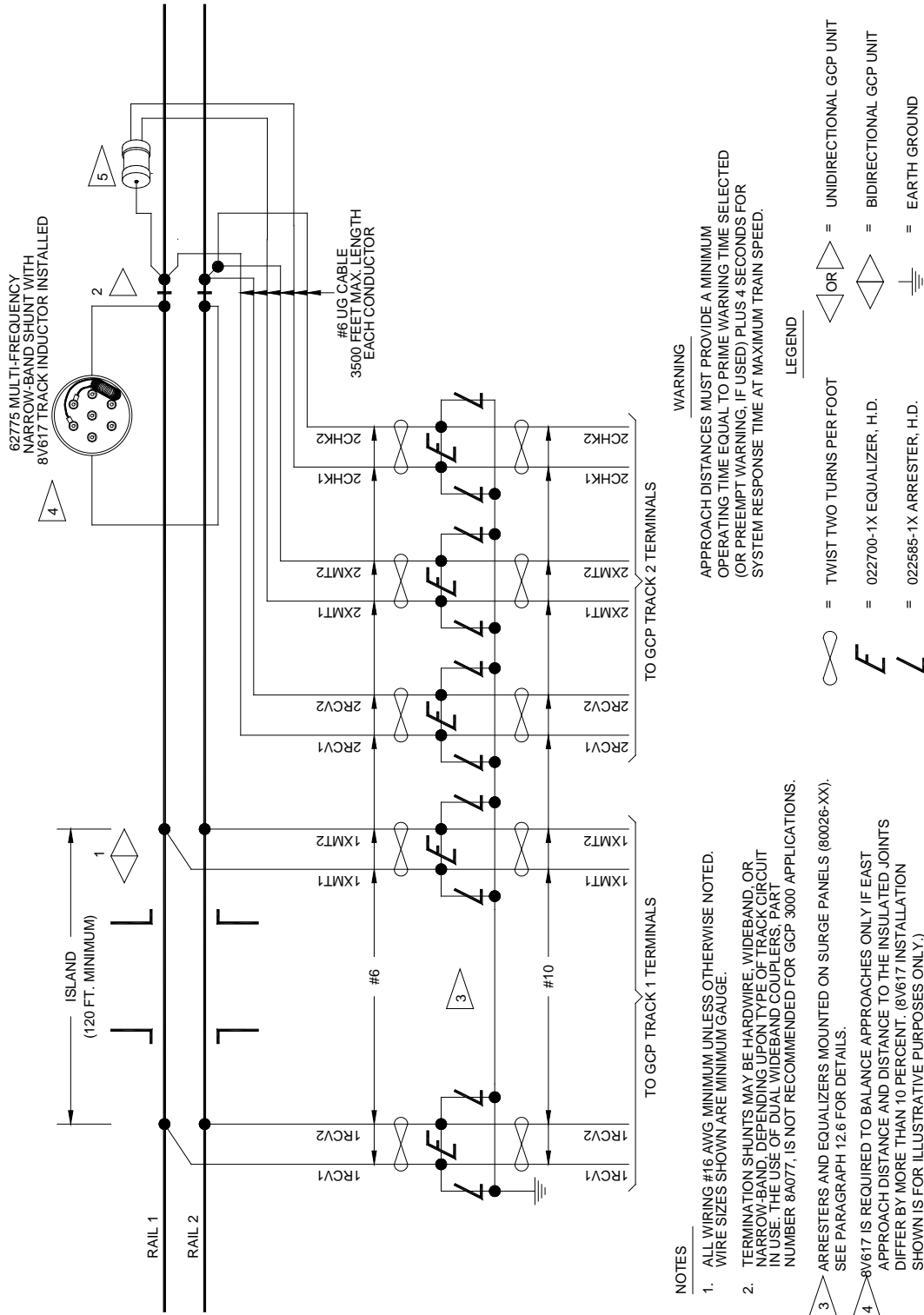


Figure 14-26: Typical Model 3000/3000D2 GCP Bidirectional Application, Unidirectional Unit With Remote Feed Point, One Track (Six-Wire), Case Wiring



NOTES

- ALL WIRING #16 AWG MINIMUM UNLESS OTHERWISE NOTED. WIRE SIZES SHOWN ARE MINIMUM GAUGE.
- TERMINATION SHUNTS MAY BE HARDWIRE, WIDEBAND, OR NARROW-BAND, DEPENDING UPON TYPE OF TRACK CIRCUIT IN USE. THE USE OF DUAL WIDEBAND COUPLERS, PART NUMBER 8A077, IS NOT RECOMMENDED FOR GCP 3000 APPLICATIONS.
- ARRESTERS AND EQUALIZERS MOUNTED ON SURGE PANELS (80026-XX). SEE PARAGRAPH 12.6 FOR DETAILS.
- 8V617 IS REQUIRED TO BALANCE APPROACHES ONLY IF EAST APPROACH DISTANCE AND DISTANCE TO THE INSULATED JOINTS DIFFER BY MORE THAN 10 PERCENT. (8V617 INSTALLATION SHOWN IS FOR ILLUSTRATIVE PURPOSES ONLY.)
- SIMULATED TRACK ASSEMBLY, 80074, IS USED IN SIX-WIRE APPLICATIONS ONLY TO PREVENT CROSSING PROTECTION ACTIVATION WHEN A TRAIN STOPS FOR AN EXTENDED PERIOD OF TIME WITH ITS WHEELS LOCATED DIRECTLY OVER OR IN CLOSE PROXIMITY TO THE SIX-WIRE TRACK CONNECTION POINTS. REFER TO SECTION 12, PARAGRAPH 12.3.3 FOR DETAILED WIRING INSTRUCTIONS.

WARNING

APPROACH DISTANCES MUST PROVIDE A MINIMUM OPERATING TIME EQUAL TO PRIME WARNING TIME SELECTED (OR PREEMPT WARNING, IF USED) PLUS 4 SECONDS FOR SYSTEM RESPONSE TIME AT MAXIMUM TRAIN SPEED.

LEGEND

= TWIST TWO TURNS PER FOOT
 OR = UNIDIRECTIONAL GCP UNIT
 = BIDIRECTIONAL GCP UNIT
 = EARTH GROUND

83-01_TYP_3K3KD2_BHUNI_RFP_1T6W_TRACK
04-09-09

Figure 14-27: Typical Model 3000/3000D2 GCP Bidirectional Application, Unidirectional Unit with Remote Feed Point, One Track (Six-Wire), Track Wiring

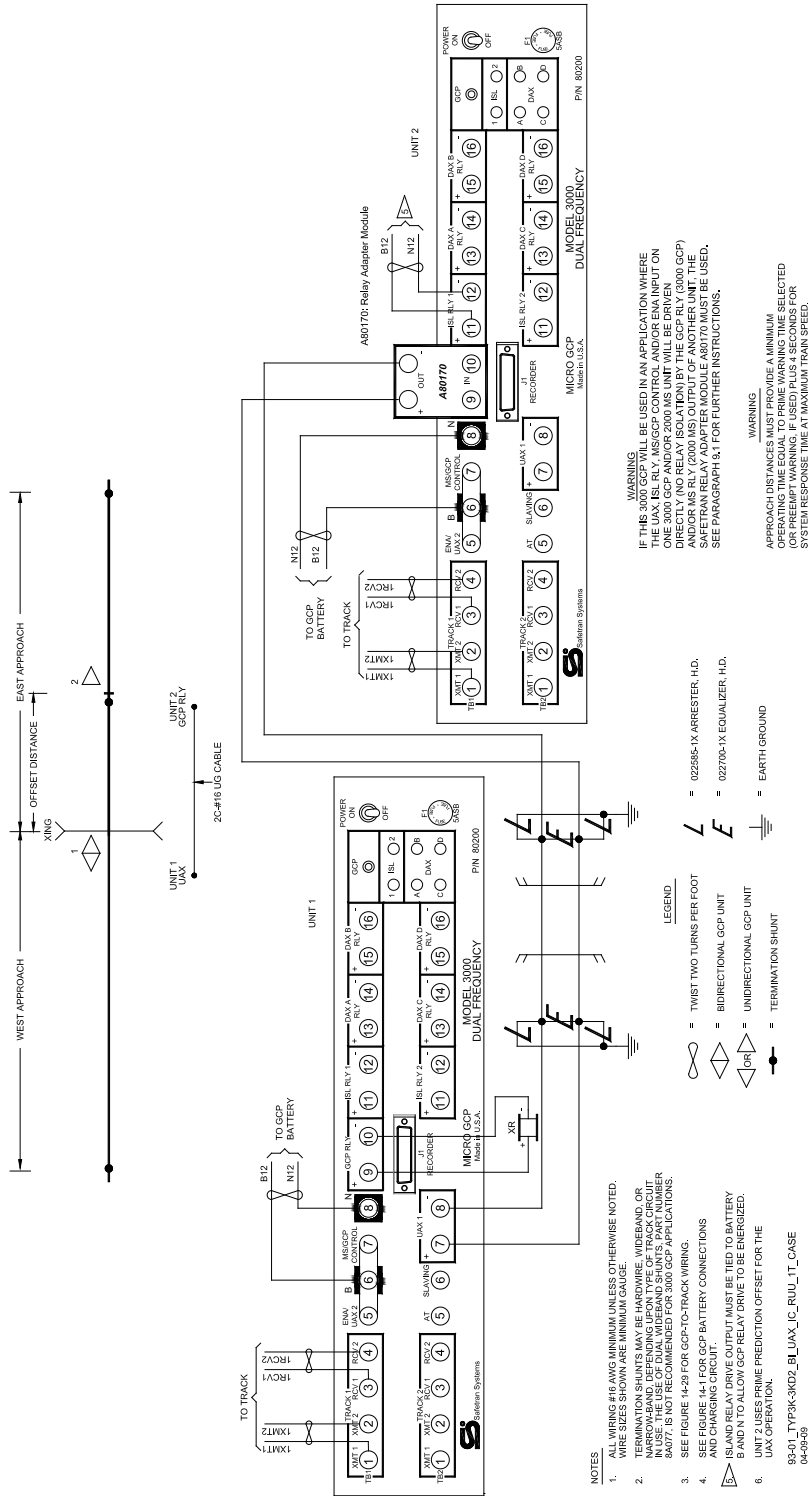


Figure 14-28: Typical Model 3000/3000D2 GCP Bidirectional UAX Interconnect Application with Remote Unidirectional Unit, One Track, Case Wiring

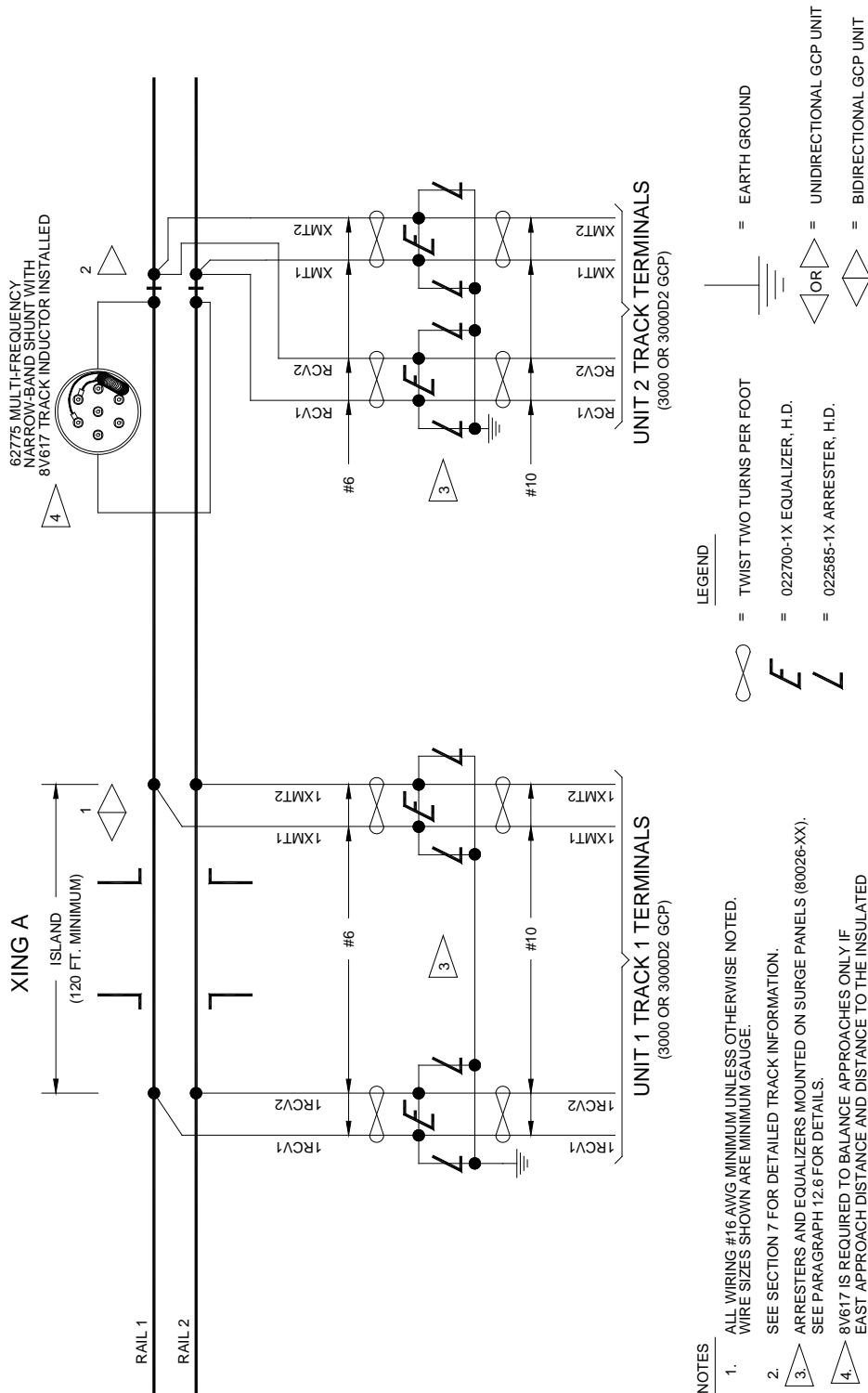


Figure 14-29: Typical Model 3000/3000D2 GCP Bidirectional UAX Interconnect Application with Remote Unidirectional Unit, One Track, Track Wiring

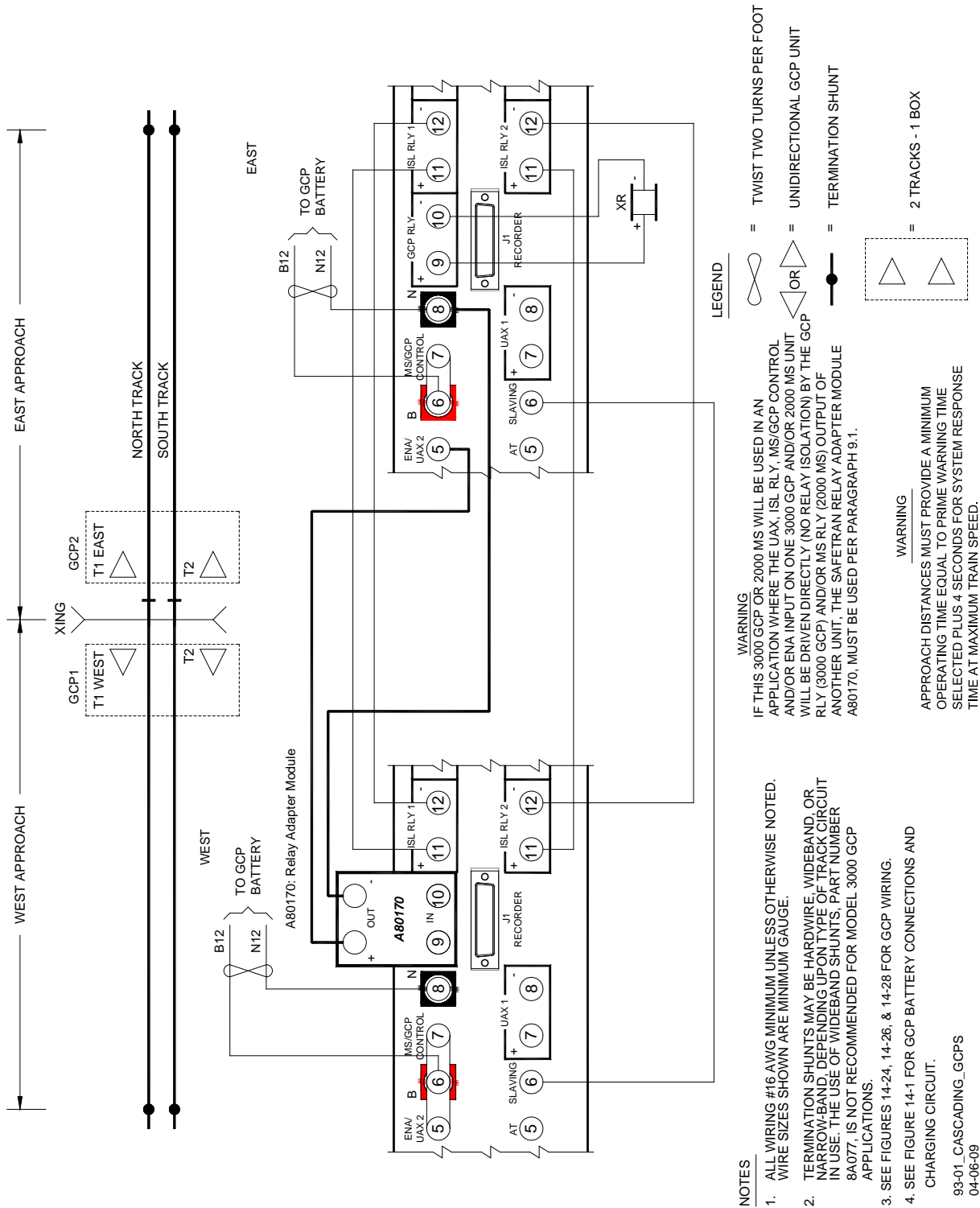


Figure 14-30: Typical Model 3000/3000D2/3000D2L GCP Unidirectional Application with Frequency Slaving and Cascaded Relay Drives, Two Tracks, Case Wiring

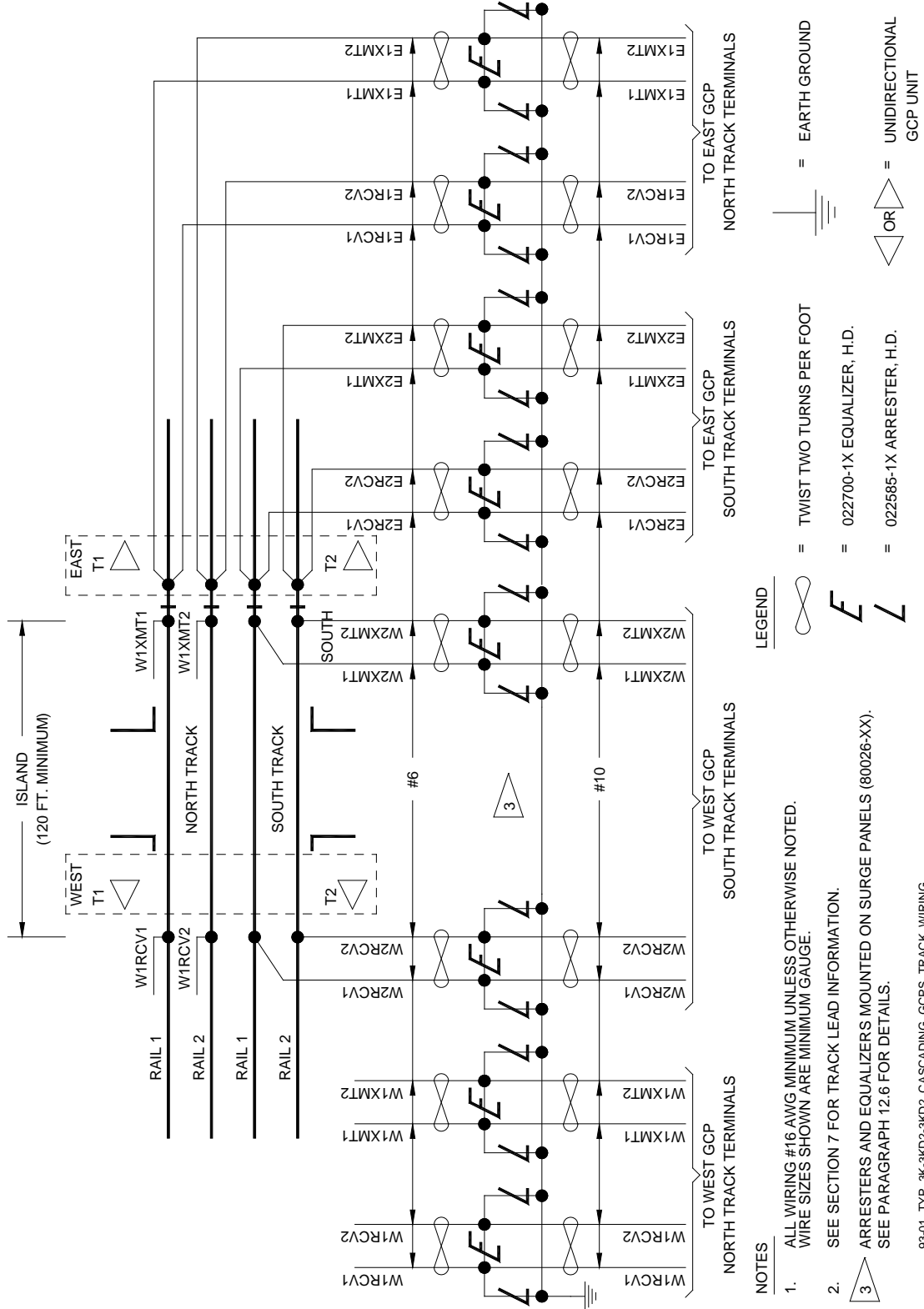


Figure 14-31: Typical Model 3000/3000D2/3000D2L GCP Unidirectional Application with Frequency Slaving and Cascaded Relay Drives, Two Tracks, Track Wiring

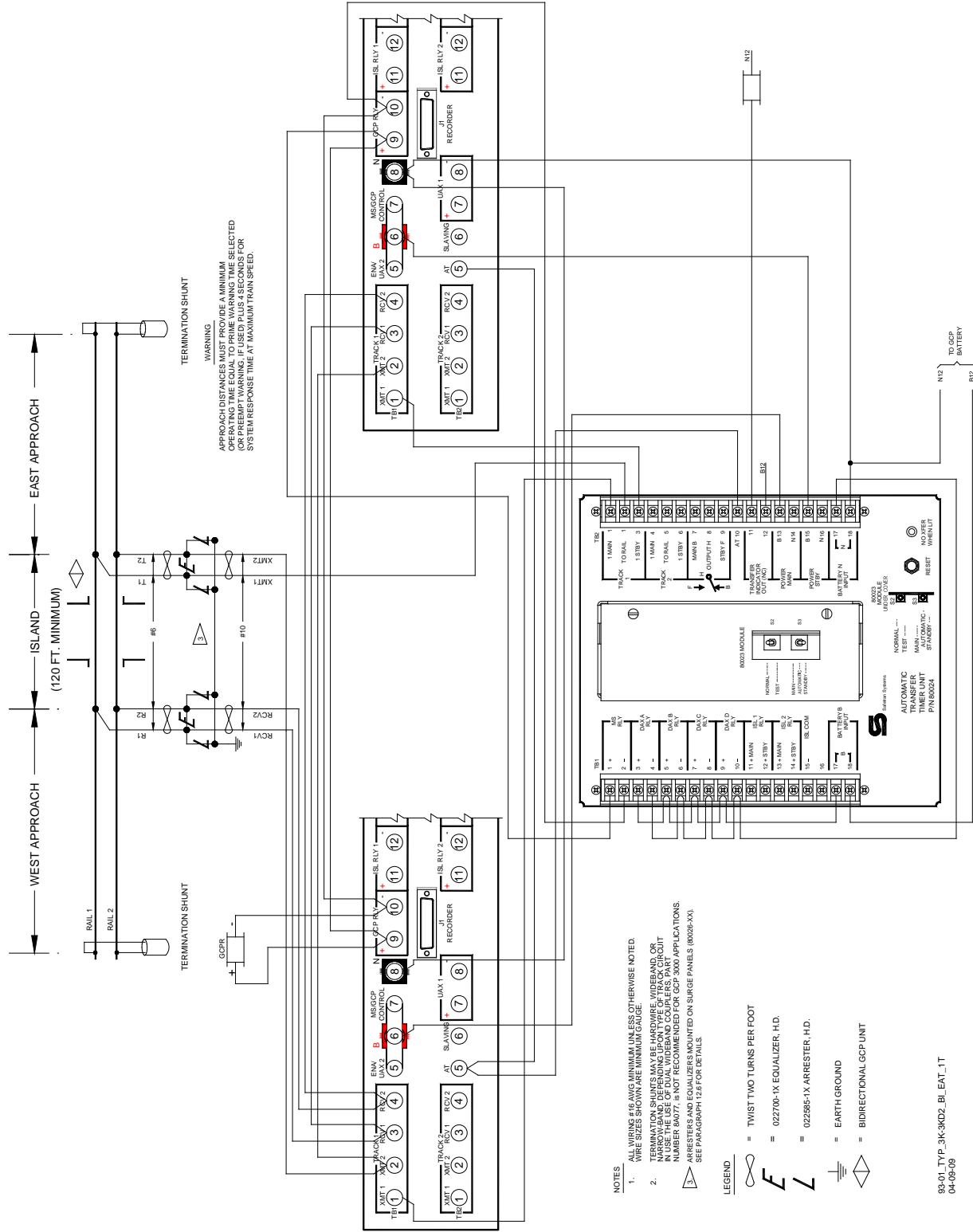


Figure 14-32: Typical Model 3000/3000D2 GCP Bidirectional Application with External Automatic Transfer, One Track

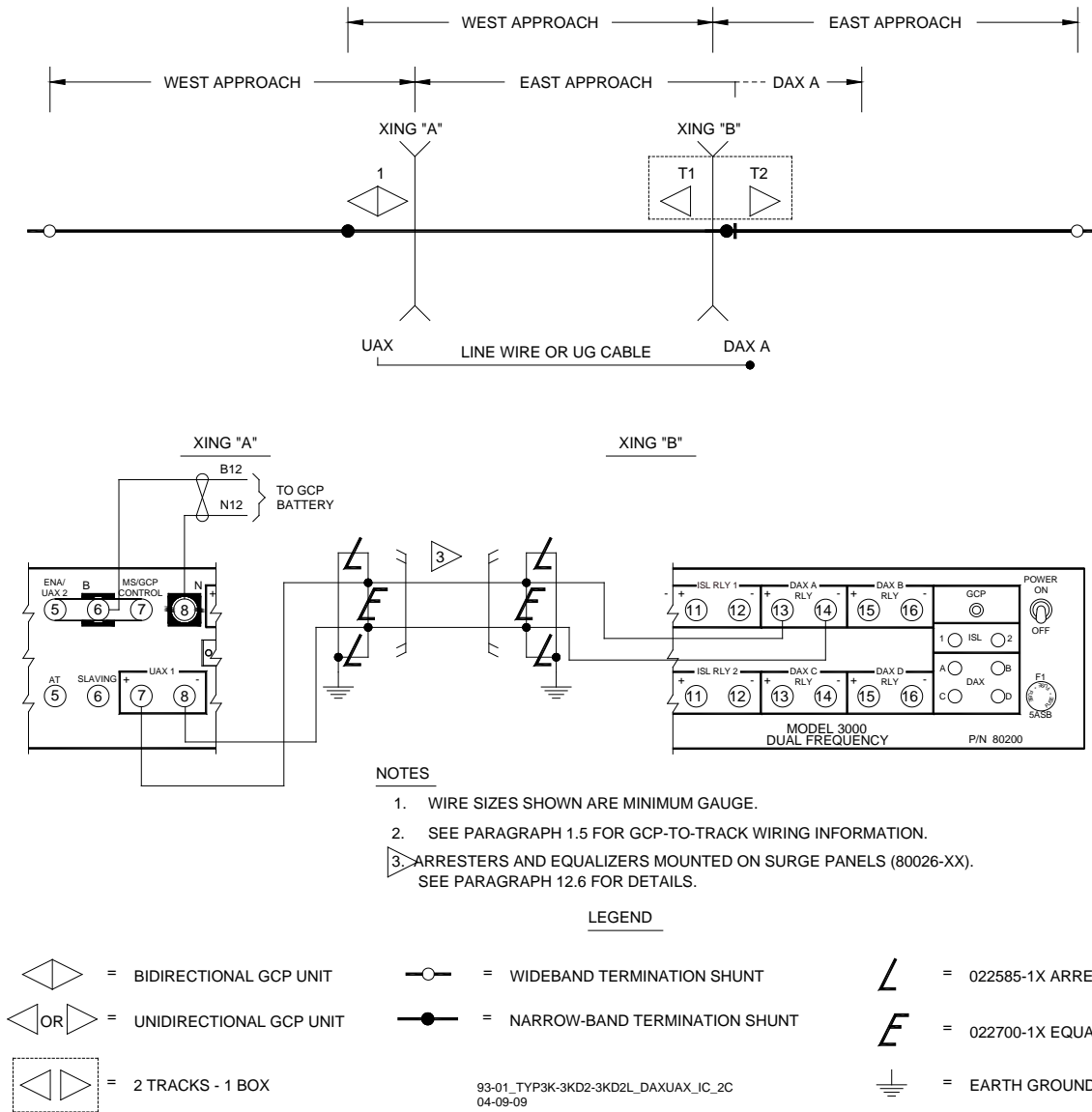


Figure 14-33: Typical Model 3000/3000D2/3000D2L GCP DAX-UAX Interconnections, Two Crossings

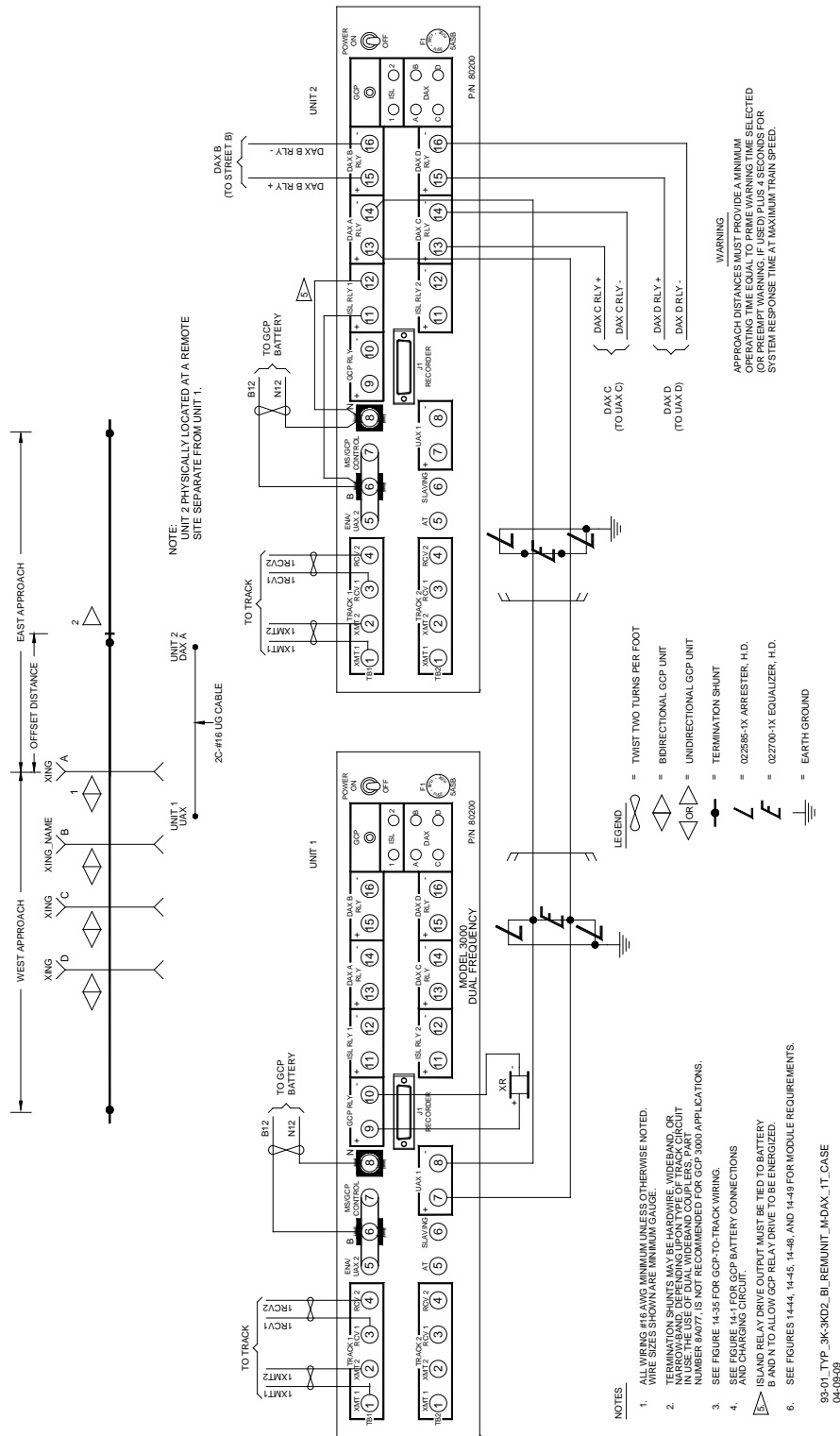


Figure 14-34: Typical Model 3000/3000D2/3008/3008D2 GCP Bidirectional Applications with Remote Unit, Multiple DAXing, One Track, Case Wiring

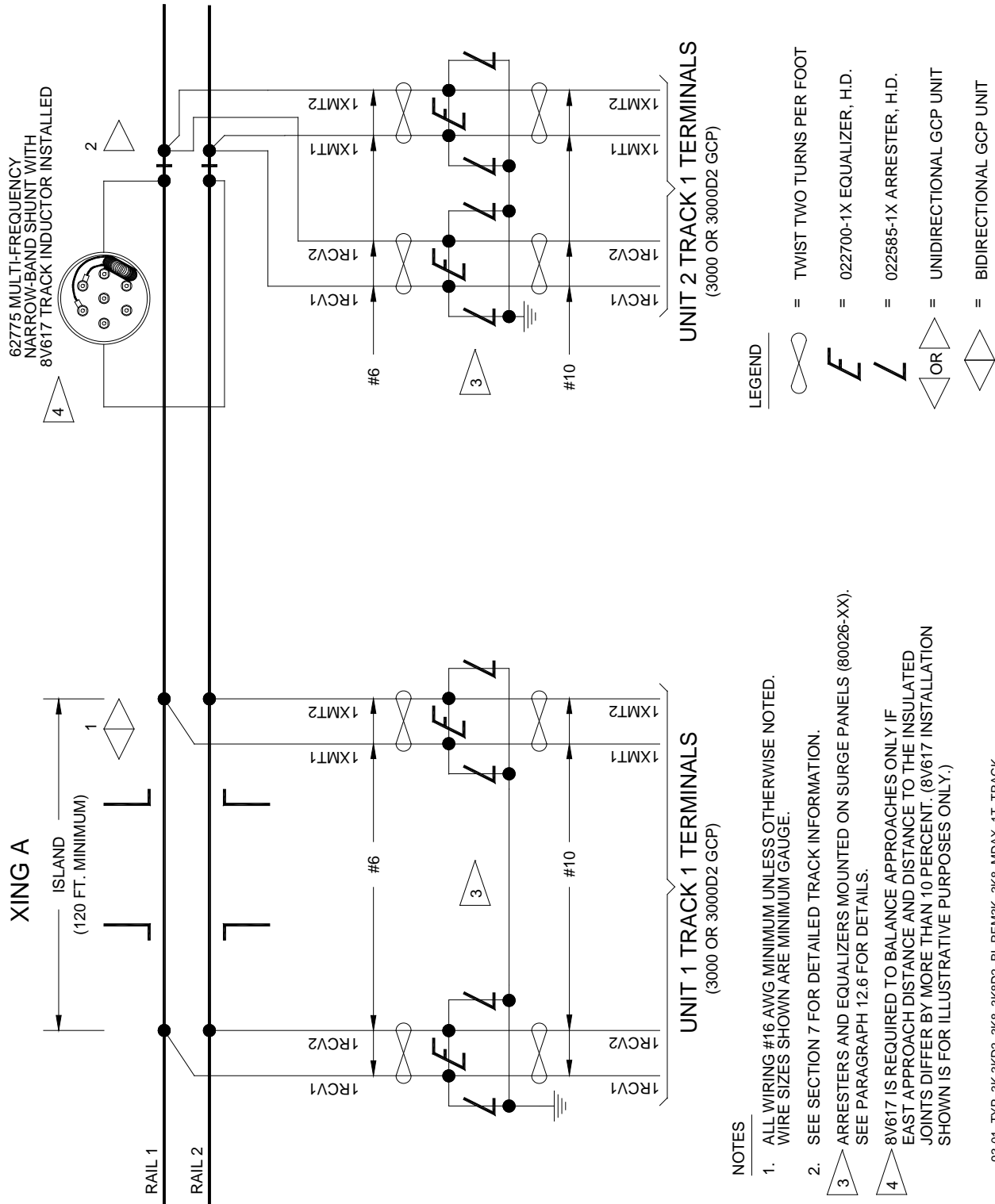
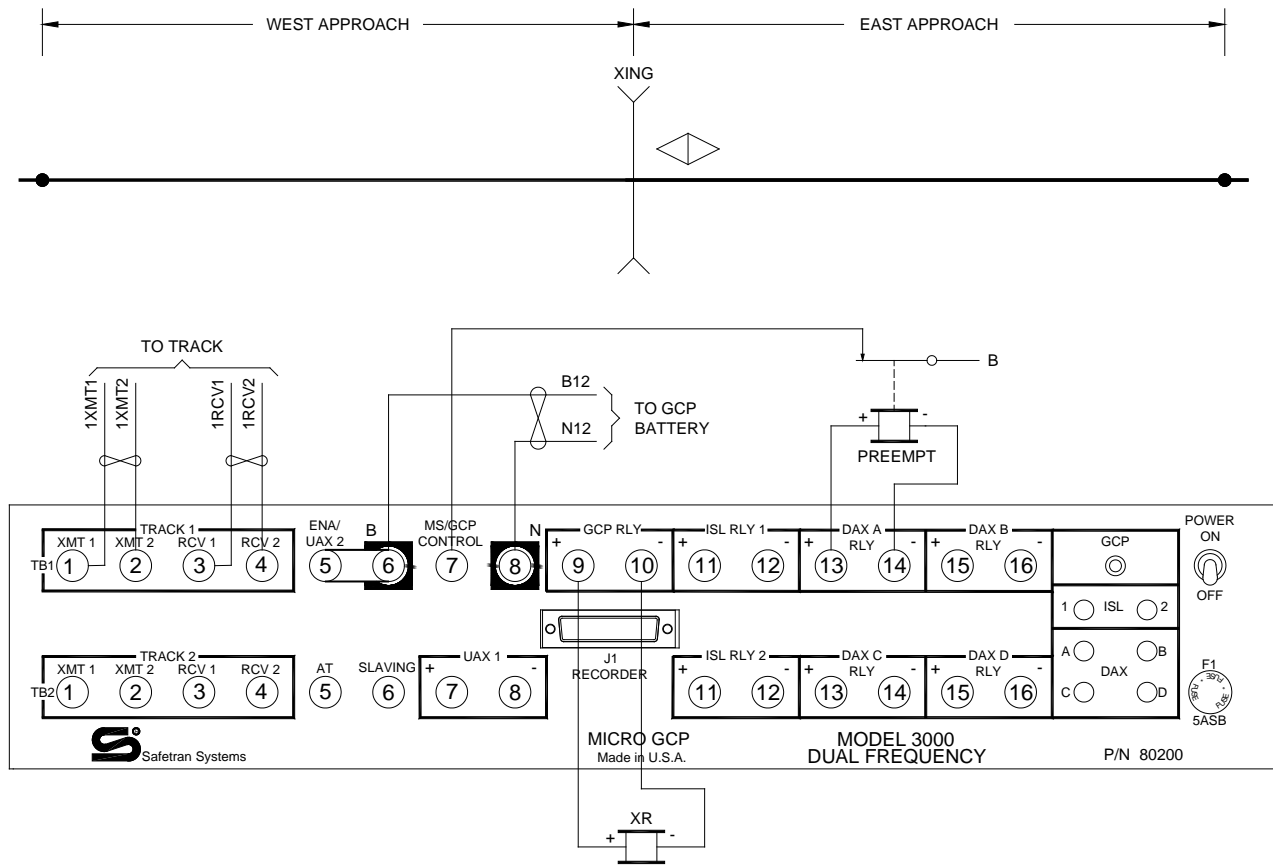


Figure 14-35: Typical Model 3000/3000D2/3008/3008D2 GCP Bidirectional Applications with Remote Model 3000/3000D2 Unit, Multiple DAXing, One Track, Track Wiring



NOTES

1. ALL WIRING #16 AWG MINIMUM UNLESS OTHERWISE NOTED. WIRE SIZES SHOWN ARE MINIMUM GAUGE.
2. TERMINATION SHUNTS MAY BE HARDWIRE, WIDEBAND, OR NARROW-BAND, DEPENDING UPON TYPE OF TRACK CIRCUIT IN USE. THE USE OF DUAL WIDEBAND SHUNTS, PART NUMBER 8A077, IS NOT RECOMMENDED FOR 3000 GCP APPLICATIONS.
3. SEE FIGURE 14-3 FOR GCP-TO-TRACK WIRING.
4. SEE FIGURE 14-1 FOR GCP BATTERY CONNECTIONS AND CHARGING CIRCUIT.

WARNING

APPROACH DISTANCES MUST PROVIDE A MINIMUM OPERATING TIME EQUAL TO PRIME WARNING TIME SELECTED (OR PREEMPT WARNING, IF USED) PLUS 4 SECONDS FOR SYSTEM RESPONSE TIME AT MAXIMUM TRAIN SPEED.

NEVER WIRE WRAP AROUND RELAY FRONT CONTACTS BETWEEN GCP RLY (+) TB1-9 AND ENA (+) TB1-5.




NOTE

CROSSING CONTROL WARNING TIME IS NORMALLY SET FROM 2 TO 5 SECONDS LESS THAN THE DESIRED WARNING TIME WITH ADVANCED PREEMPTION TIMER ENABLED.

THE FOLLOWING PROGRAMMING IS REQUIRED TO ENABLE THE ADVANCED PREEMPTION TIMER APPLICATION:

1. PROGRAM DAX A: TRACK 1
2. PROGRAM DAX A DISTANCE: PREEMPT
3. PROGRAM DAX A WARNING TIME: 40 (SECONDS)
4. ADVANCED PREEMPT TIMER: 10 (SECONDS)
5. PROGRAM T1 WARNING TIME: 25 TO 28 (SECONDS)

LEGEND

-  = TWIST TWO TURNS PER FOOT
-  = BIDIRECTIONAL GCP UNIT
-  = TERMINATION SHUNT

93-01_TYP_3K-3KD2_BI_ADV-PREMT-TMR_1T_CASE
04-09-09

Figure 14-36: Typical Model 3000/3000D2 GCP Bidirectional Advanced Preempt Timer Application, One Track, Case Wiring

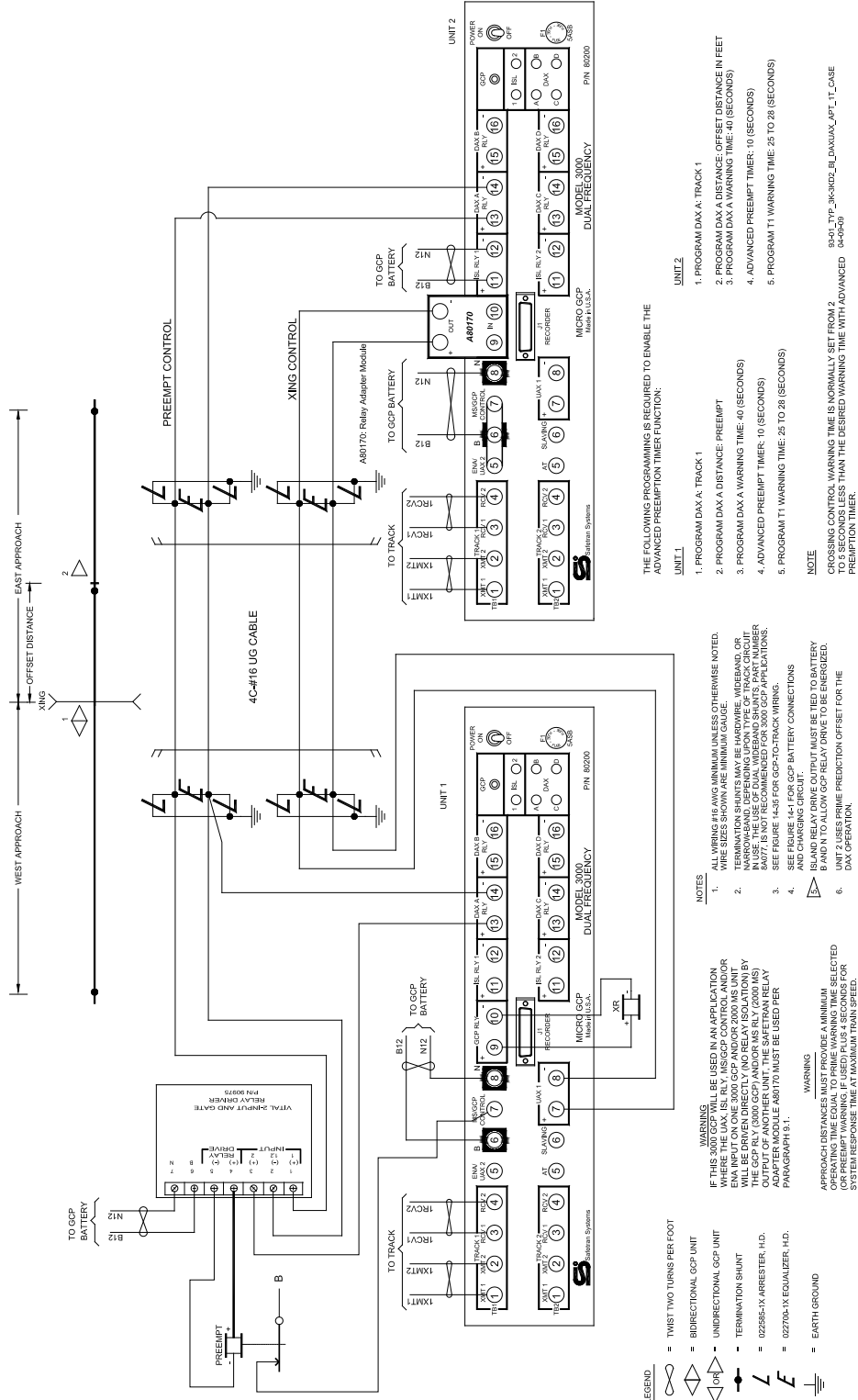
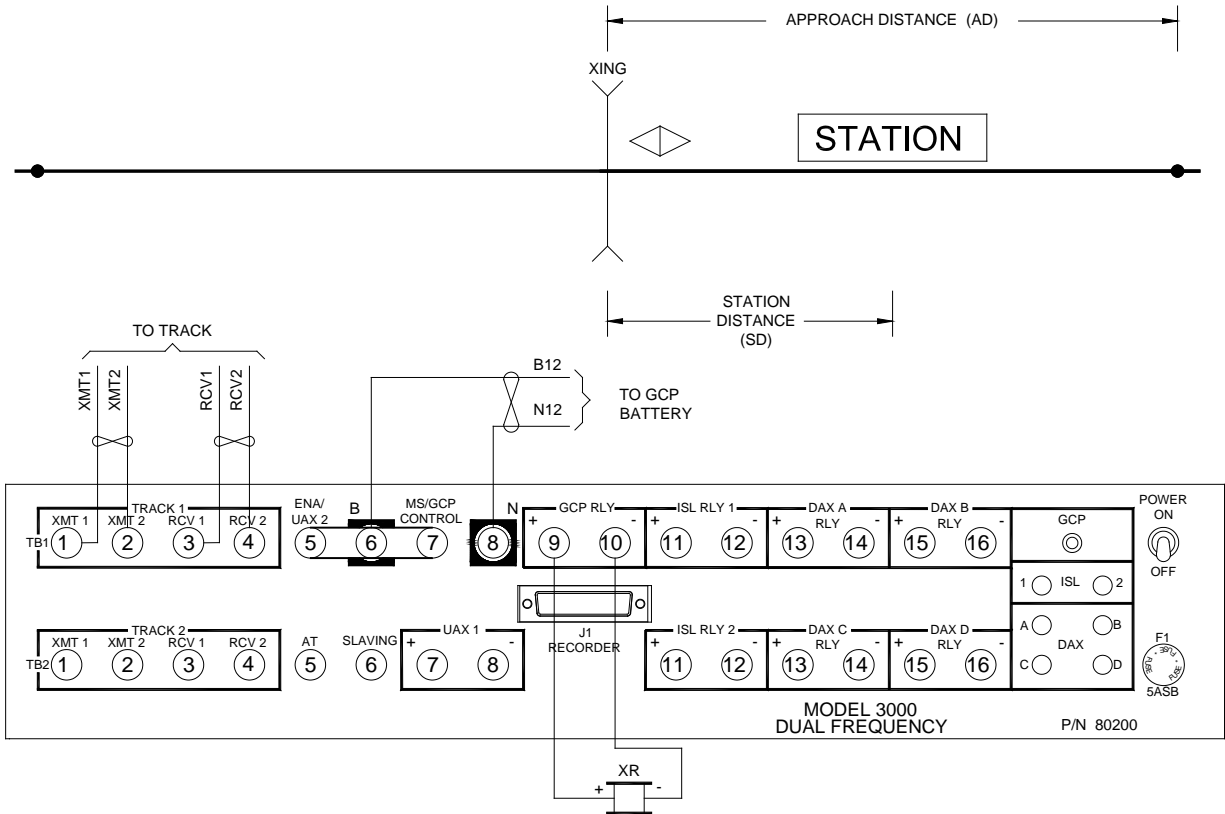


Figure 14-37: Typical Model 3000/3000D2 GCP Bidirectional DAX-UAX Interconnect Advanced Preempt Timer Application, One Track, Case Wiring



NOTES

1. WIRE SIZES SHOWN ARE MINIMUM GAUGE.
2. TERMINATION SHUNTS MAY BE HARDWIRE, WIDEBAND, OR NARROW-BAND, DEPENDING UPON TYPE OF TRACK CIRCUIT IN USE. THE USE OF DUAL WIDEBAND SHUNTS, PART NUMBER 8A077, IS NOT RECOMMENDED FOR 3000 GCP APPLICATIONS.
3. SEE FIGURE 14-3 FOR GCP-TO-TRACK WIRING.
4. SEE FIGURE 14-1 FOR GCP BATTERY CONNECTIONS AND CHARGING CIRCUIT.

LEGEND

- = TWIST TWO TURNS PER FOOT
- = BIDIRECTIONAL GCP UNIT
- = TERMINATION SHUNT

WARNING

APPROACH DISTANCES MUST PROVIDE A MINIMUM OPERATING TIME EQUAL TO PRIME WARNING TIME SELECTED (OR PREEMPT WARNING, IF USED) PLUS 4 SECONDS FOR SYSTEM RESPONSE TIME AT MAXIMUM TRAIN SPEED.

NEVER WIRE WRAP AROUND RELAY FRONT CONTACTS BETWEEN GCP RLY (+) TB1-9 AND ENA (+) TB1-5.

THE FOLLOWING PROGRAMMING IS REQUIRED TO ENABLE A GCP TO TEMPORARILY SWITCH TO MOTION SENSOR OPERATION AS A TRAIN ACCELERATES FROM THE STATION:

1. SET MOTION SENSING LEVEL T1:

THE MOTION SENSITIVITY LEVEL (MSL) IS CALCULATED BY DIVIDING THE DISTANCE FROM THE GCP RECEIVER FEED WIRES TO THE MIDDLE OF THE STATION (SD) BY THE DISTANCE FROM THE GCP TO THE LONGEST APPROACH TERMINATION SHUNT (AD) AND THEN MULTIPLYING THE RESULT BY 100.

$$\frac{SD}{AD} \times 100 = MSL$$

2. TRANSFER DELAY MS TO GCP T1:

THE TRANSFER DELAY TIME (TD) IS CALCULATED BY DETERMINING THE LONGEST TIME A TRAIN WILL REMAIN STOPPED AT A STATION (ST) AND ADDING AN APPROACH CLEARANCE TIME OF 60 SECONDS.

$$ST + 60 = TD$$

93-01_TYP_3K-3KD2_BI_SW2MS_1T
04-09-09

Figure 14-38: Typical Model 3000/3000D2 GCP Bidirectional Switch to Motion Sensor Application, One Track, Case Wiring

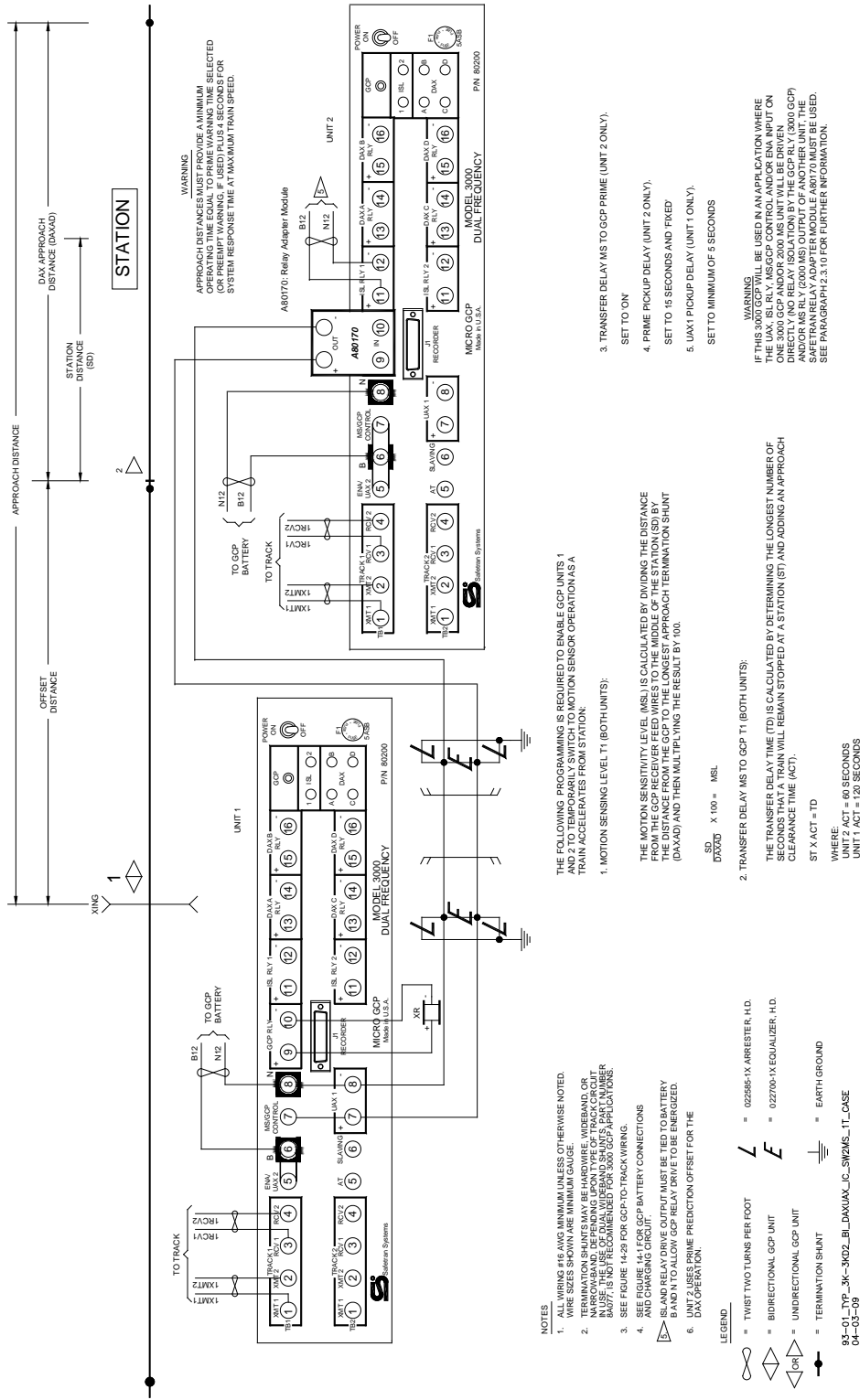


Figure 14-39: Typical Model 3000/3000D2 GCP Bidirectional DAX-UAX Interconnect Switch to Motion Sensor Application, One Track, Case Wiring

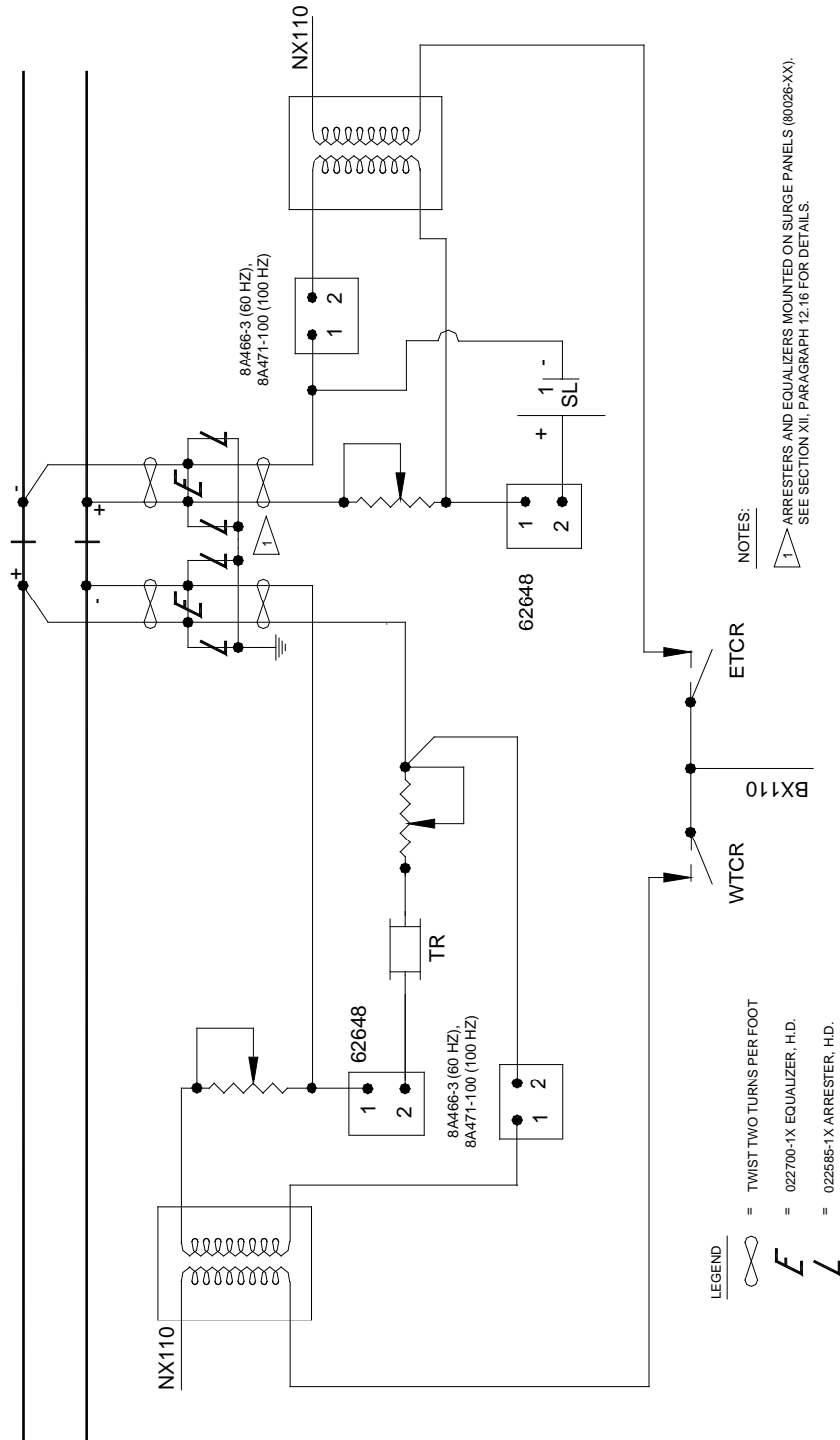


Figure 14-40: Steady Energy DC Track Circuit with 60 or 100 Hz Cab Signal

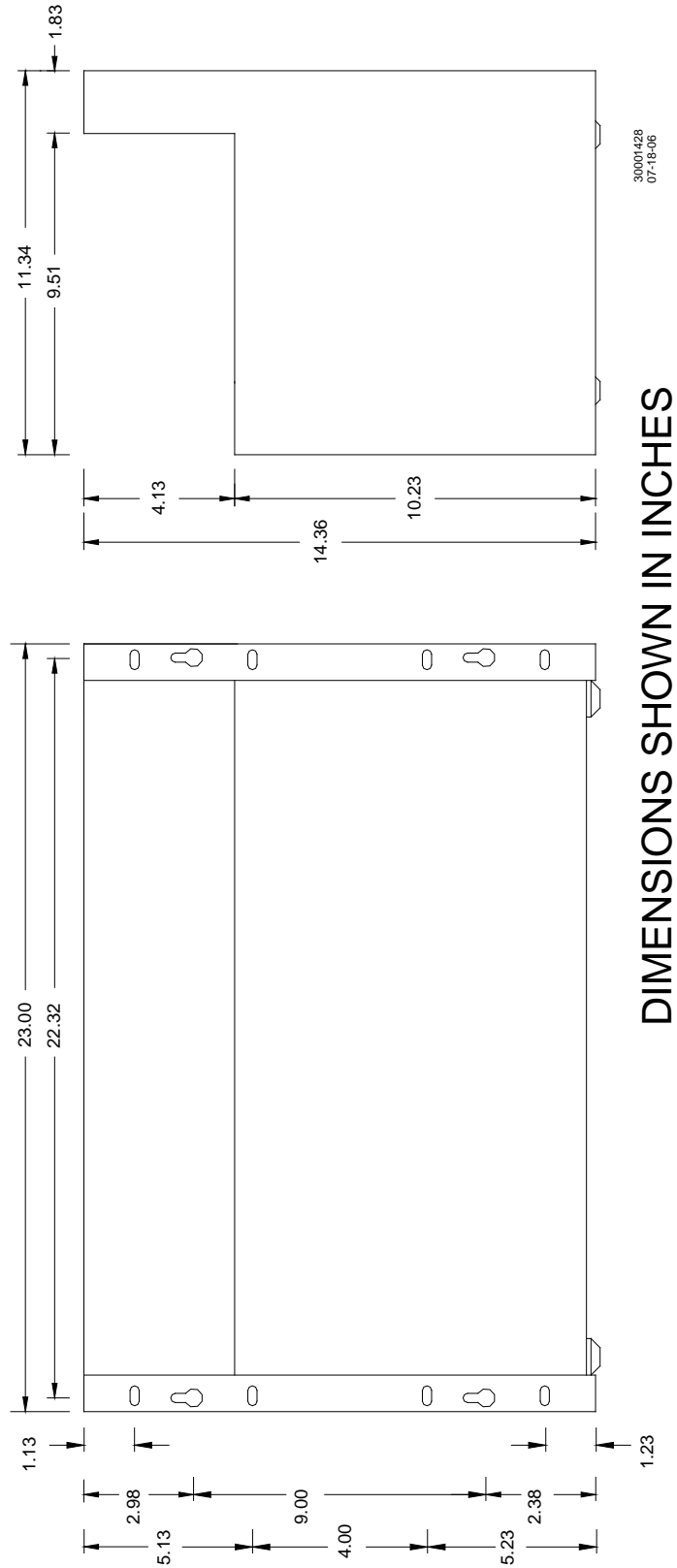
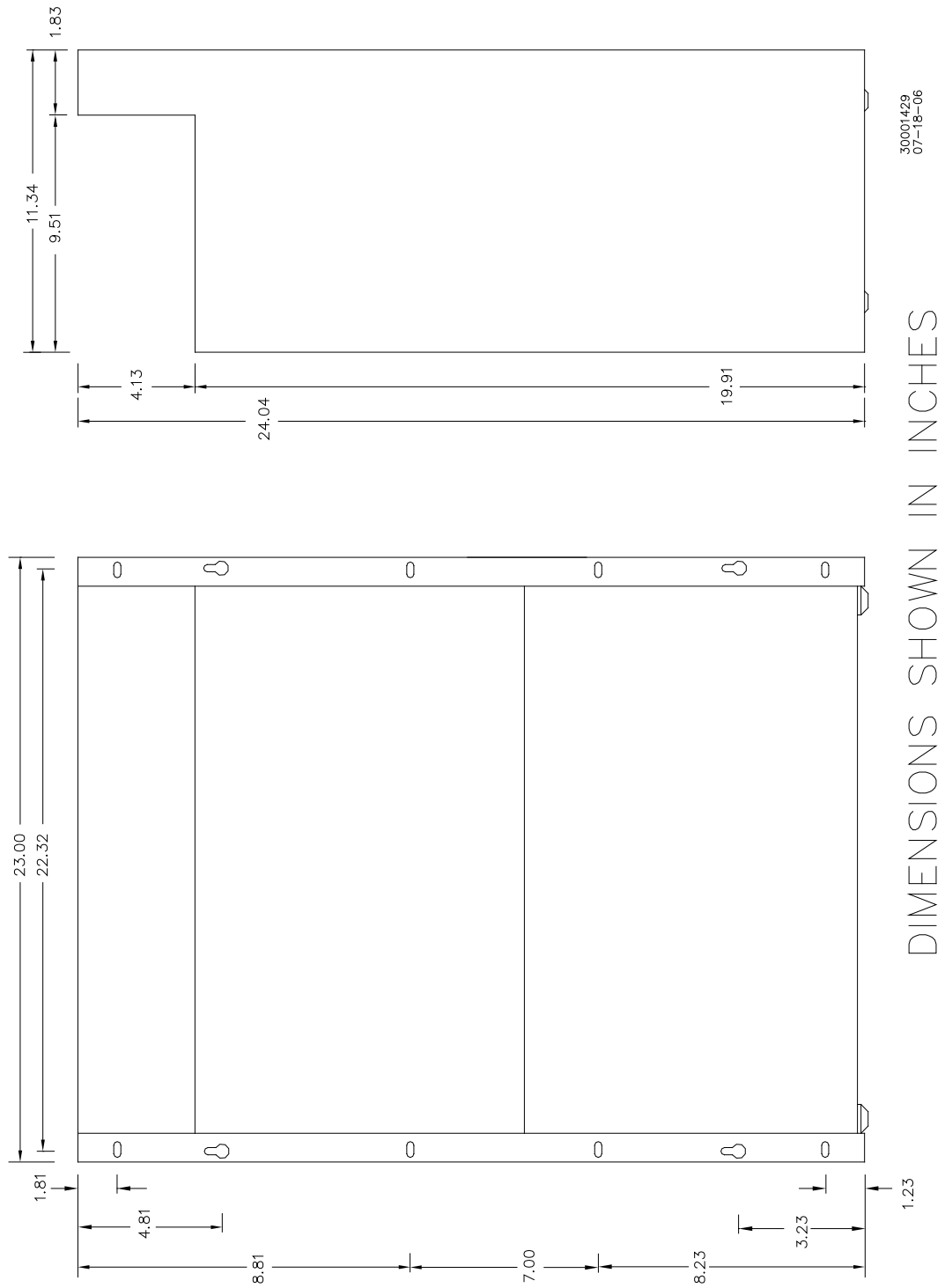
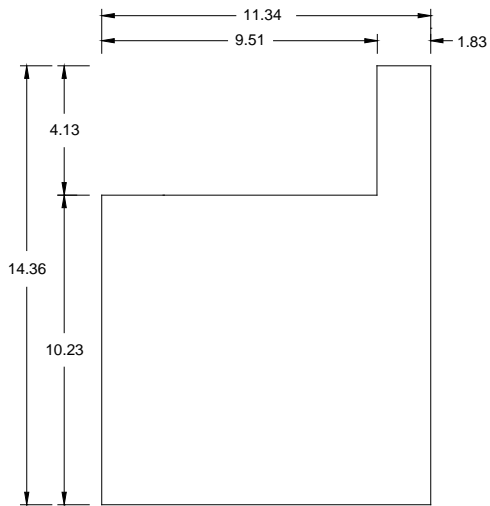
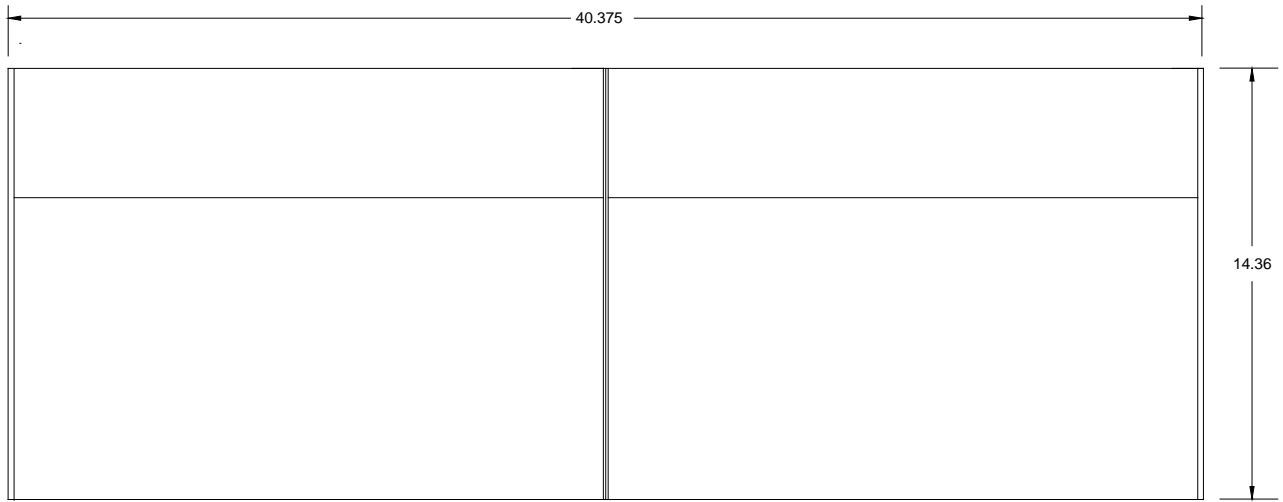


Figure 14-41: Mounting Dimensions, Model 3000, 3000ND, 3000ND2, and 3008 GCPs



DIMENSIONS SHOWN IN INCHES

Figure 14-42: Mounting Dimensions, Model 3000D2 and 3008D2 GCPs



00_02_3000D2L_MT_DIR
01-17-08

Figure 14-43: Mounting Dimensions, Model 3000D2L GCP

LIST OF MODULES

ASSY. NO.	MODULE DESCRIPTION	ASSY. NO.	MODULE DESCRIPTION
80211	ISLAND MODULE	80115	DATA RECORDER MODULE
80012	TRANSCIEVER MODULE	80016	DAX MODULE
80013	RELAY DRIVE MODULE	80020	INTERFACE ASSEMBLY
80214	PROCESSOR MODULE		

		MODULES/ASSEMBLIES									
MODULE POSITION →		M1	M2	M3	M4	M5	M6	M7	M8	M9	M10
MODEL 3000 GCP		*									
FIGURE NO.	UNIT NO.	80211	80211	80012	80012	80013	80214	80115	80016	80016	80020 **
14-2, 14-30 14-36, 14-39		X		X		X	X	O			X
14-4, 14-31W		X	X	X	X	X	X	O			X
14-2, 14-30 14-36, 14-39		X		X	X	X	X	O			X
14-24	1	X		X	X	X	X	O			X
14-18, 14-24 14-28	14-24, 2			X		X	X	O			X
14-33, 14-37	A	X		X		X	X	O			X
14-33, 14-37	B		X	X	X	X	X	O	X		X
14-31, 14-34			X	X	X	X	X	O			X
14-22		X		X	X	X	X	O			X
14-20				X	X	X	X	O			X

X = REQUIRED
 O = OPTIONAL
 * = 1ST SLOT AT LEFT END OF CASE.
 ** = KEYBOARD/DISPLAY CONTROL UNIT, 80019,
 PLUGS INTO THE 80020 INTERFACE ASSEMBLY
 FOR PROGRAMMING AND DISPLAY.

93-01_LOM_3000
 04-10-09

Figure 14-44: Model 3000 GCP Module Selection Chart

MODEL 3000 GCP APPLICATION DIAGRAMS

LIST OF MODULES

ASSY. NO.	MODULE DESCRIPTION	ASSY. NO.	MODULE DESCRIPTION
80211	ISLAND MODULE	80115	DATA RECORDER MODULE
80012	TRANSCIVER MODULE	80016	DAX MODULE
80013	RELAY DRIVE MODULE	80020	CONTROL INTERFACE (INCLUDES 80017 KEYBOARD DISPLAY INTERFACE)
80214	PROCESSOR MODULE	80028	TRANSFER MODULE

		MODULE ASSEMBLIES																					
		UPPER BAY											LOWER BAY										
MODULE POSITION →		M1	M2	M3	M4	M5	M6	M7	M8	M9	M10	M11	M12	M13	M14	M15	M16	M17	M18	M19	M20	M21	
MODEL 3000D2 GCP		*										*											
FIGURE NO.	UNIT NO.	80211	80211	80012	80012	80013	80214	80115	80016	80016	80020**	80211	80211	80012	80012	80013	80214	80115	80016	80016	80020**	80028	
14-2, 14-30 14-36, 14-39		X		X		X	X	O			X	X		X		X	X	O			X	X	
14-4, 14-31W		X	X	X	X	X	X	O			X	X	X	X	X	X	X	O			X	X	
14-6, 14-8 14-26		X		X	X	X	X	O			X	X		X	X	X	X	O			X	X	
14-6	1	X		X		X	X	O			X	X		X		X	X	O			X	X	
14-18, 14-24 14-28	14-24, 2			X		X	X	O			X			X		X	X	O			X	X	
14-31E, 14-34				X	X	X	X	O			X			X	X	X	X	O			X	X	
14-22		X		X	X	X	X	O			X	X		X	X	X	X	O			X	X	
14-33, 14-37	A	X		X		X	X	O			X	X		X		X	X	O			X	X	
14-33, 14-37	B		X	X	X	X	X	O	X		X		X	X	X	X	X	O	X		X	X	
14-20				X	X	X	X	O			X			X	X	X	X	O			X	X	

X = REQUIRED

O = OPTIONAL

* = 1ST SLOT AT LEFT END OF BAY

** = KEYBOARD/DISPLAY CONTROL UNIT, 80019,
PLUGS INTO THE 80020 INTERFACE ASSEMBLY
FOR PROGRAMMING AND DISPLAY.

93-01_LOM_3000D2
04-10-09

Figure 14-45: Model 3000D2 GCP Module Selection Chart

LIST OF MODULES

ASSY. NO.	MODULE DESCRIPTION
80211	ISLAND MODULE
80012	TRANSCIEVER MODULE
80013	RELAY DRIVE MODULE
80214	PROCESSOR MODULE
80115	DATA RECORDER MODULE
80020	CONTROL INTERFACE (INCLUDES 80017 KEYBOARD DISPLAY INTERFACE)

		MODULES/ASSEMBLIES									
MODULE POSITION →		M1	M2	M3	M4	M5	M6				
MODEL 3000ND GCP		*					**				
FIGURE NO.	UNIT NO.	80211	80012	80013	80214	80115	80020				
14-10, 14-11 14-12, 14-13	1 1, 2	X	X	X	X	O	X				
14-11 14-16	2 1, 2		X	X	X	O	X				

X = REQUIRED

O = OPTIONAL

* = 1ST SLOT AT LEFT END OF CASE.

** = KEYBOARD/DISPLAY CONTROL UNIT, 80019,
PLUGS INTO THE 80020 INTERFACE ASSEMBLY
FOR PROGRAMMING AND DISPLAY.

93-01_LOM_3000ND
04-10-09

Figure 14-46: Model 3000ND GCP Module Selection Chart

LIST OF MODULES

ASSY. NO.	MODULE DESCRIPTION
80211	ISLAND MODULE
80012	TRANSCEIVER MODULE
80013	RELAY DRIVE MODULE
80214	PROCESSOR MODULE
80115	DATA RECORDER MODULE
80029	CONTROL INTERFACE (INCLUDES 80153 KEYBOARD DISPLAY INTERFACE)
80028	TRANSFER MODULE

		MODULE ASSEMBLIES																											
MODULE POSITION →		M1	M2	M3	M4	M5	M6	M7	M8	M9	M10	M11	M12																
MODEL 3000ND2 GCP		*					**																						
FIGURE NO.	UNIT NO.	80211	80012	80013	80214	80115	80029	80015	80014	80013	80012	80011-f	80028																
14-10, 14-11 14-12, 14-13	1 1, 2	X	X	X	X	O	X	O	X	X	X	X	X																
14-11 14-16	2 1, 2		X	X	X	O	X	O	X	X	X		X																

X = REQUIRED
 O = OPTIONAL
 * = 1ST SLOT AT LEFT END OF BAY
 ** = KEYBOARD/DISPLAY CONTROL UNIT, 80019,
 PLUGS INTO THE 80029 INTERFACE ASSEMBLY
 FOR PROGRAMMING AND DISPLAY.

93-01_LOM_3000ND2
 04-10-09

Figure 14-47: Model 3000ND2 GCP Module Selection Chart

LIST OF MODULES

ASSY. NO.	MODULE DESCRIPTION
80211	ISLAND MODULE
80012	TRANSCEIVER MODULE
80013	RELAY DRIVE MODULE
80214	PROCESSOR MODULE
80115	DATA RECORDER MODULE
80016	DAX MODULE
80020	INTERFACE ASSEMBLY

		MODULES/ASSEMBLIES									
MODULE POSITION →		M1	M2	M3	M4	M5	M6	M7	M8	M9	M10
MODEL 3008 GCP		*									**
FIGURE NO.	UNIT NO.	80211	80012	80013	80214	80115	80016	80016	80016	80016	80020
14-34			X	X	X	O	X	X	X		X

NOTE: NO ISLAND USED-FIRST SLOT LEFT EMPTY.

93-01_LOM_3008
04-10-09

X = REQUIRED

O = OPTIONAL

* = 1ST SLOT AT LEFT END OF CASE.

** = KEYBOARD/DISPLAY CONTROL UNIT, 80019,
PLUGS INTO THE 80020 INTERFACE ASSEMBLY
FOR PROGRAMMING AND DISPLAY.

Figure 14-48: Model 3008 GCP Module Selection Chart

LIST OF MODULES

ASSY. NO.	MODULE DESCRIPTION
80211	ISLAND MODULE
80012	TRANSCEIVER MODULE
80013	RELAY DRIVE MODULE
80214	PROCESSOR MODULE
80115	DATA RECORDER MODULE
80016	DAX MODULE
80020	CONTROL INTERFACE (INCLUDES 80017 KEYBOARD DISPLAY INTERFACE)
80037	TRANSFER MODULE

		MODULE ASSEMBLIES																				
		UPPER BAY										LOWER BAY										
MODULE POSITION →		M1	M2	M3	M4	M5	M6	M7	M8	M9	M10	M11	M12	M13	M14	M15	M16	M17	M18	M19	M20	M21
MODEL 3008D2 GCP		*									**	*									**	
FIGURE NO.	UNIT NO.	80211	80012	80013	80214	80115	80016	80016	80016	80016	80020	80211	80012	80013	80214	80115	80016	80016	80016	80016	80020	80037
14-34			X	X	X	O	X	X	X		X		X	X	X	O	X	X	X		X	X

93-01-LOM_3008D2
04-10-09

NOTE: NO ISLAND USED-FIRST SLOT LEFT EMPTY.

X = REQUIRED

O = OPTIONAL

* = 1ST SLOT AT LEFT END OF BAY

** = KEYBOARD/DISPLAY CONTROL UNIT, 80019,
PLUGS INTO THE 80020 INTERFACE ASSEMBLY
FOR PROGRAMMING AND DISPLAY.

Figure 14-49: Model 3008D2 GCP Module Selection Chart

SECTION 15 – SURGE PROTECTION

15.1 GENERAL

The key to effective surge protection for the 3000 GCP as well as other associated electronic equipment is an integrated combination of the following:

1. Effective primary surge protection,
2. Proper built-in secondary and tertiary surge protection within the electronic equipment,
3. Appropriate wiring of all equipment within the case/bungalow,
4. Low resistance connection to earth ground.

The major requirement of primary surge protection is to reduce all surges to a level the electronic equipment can withstand. To achieve this, all wiring entering or exiting a case or bungalow must be equipped with primary surge protection. Four major areas require primary surge protection, as well as appropriate sequential bungalow wiring, and include:

1. AC power lines
2. Battery
3. Track wires
4. Line circuits

15.2 AC POWER LINES

The AC power line provides power to the battery charger which supplies charging current to the battery for powering the GCP and other electronic equipment located in the case/bungalow. The AC line requires surge decoupling, which is provided by an SP20-2A AC Line Protector plus an AC power line arrester as shown in Figure 15-1. Optionally, a rack-mounted AC surge panel may also be used.

15.3 BATTERY

The battery also requires primary surge protection to minimize the amplitude of voltage transients occurring on the AC line which pass through the charger or line circuits to the battery. The battery must be included in the surge protection network since the low internal impedance of the battery makes it an extremely effective transient filter or surge arresting device (see Figure 15-1). This is accomplished by connecting a number 6 AWG wire pair twisted two turns per foot from the battery charger output to the battery terminals and then using a second number 6 AWG twisted pair from the battery terminals to the battery equalizer/arrester surge protection network (see Figure 15-2). A battery bus can then be formed to power the GCP and any other electronic equipment housed within the case/bungalow. This sequence of wiring is very important to the success of the surge arresting equipment and subsequent reliability of the electronic equipment.

15.4 TRACK WIRES

The GCP track wires must be surge decoupled through use of arresters and equalizers at the entrance of the track leads to the equipment housing. This is also accomplished on an equipment rack through use of the appropriate track surge panel (see Figure 15-2).

15.5 LINE CIRCUITS

Line and underground cable circuits entering or exiting the case/bungalow require surge decoupling through the arrester/ equalizer network (see Figure 15-3). A separate network must be installed for each wire pair connecting the GCP, plus other electronic equipment where applicable, to the battery.

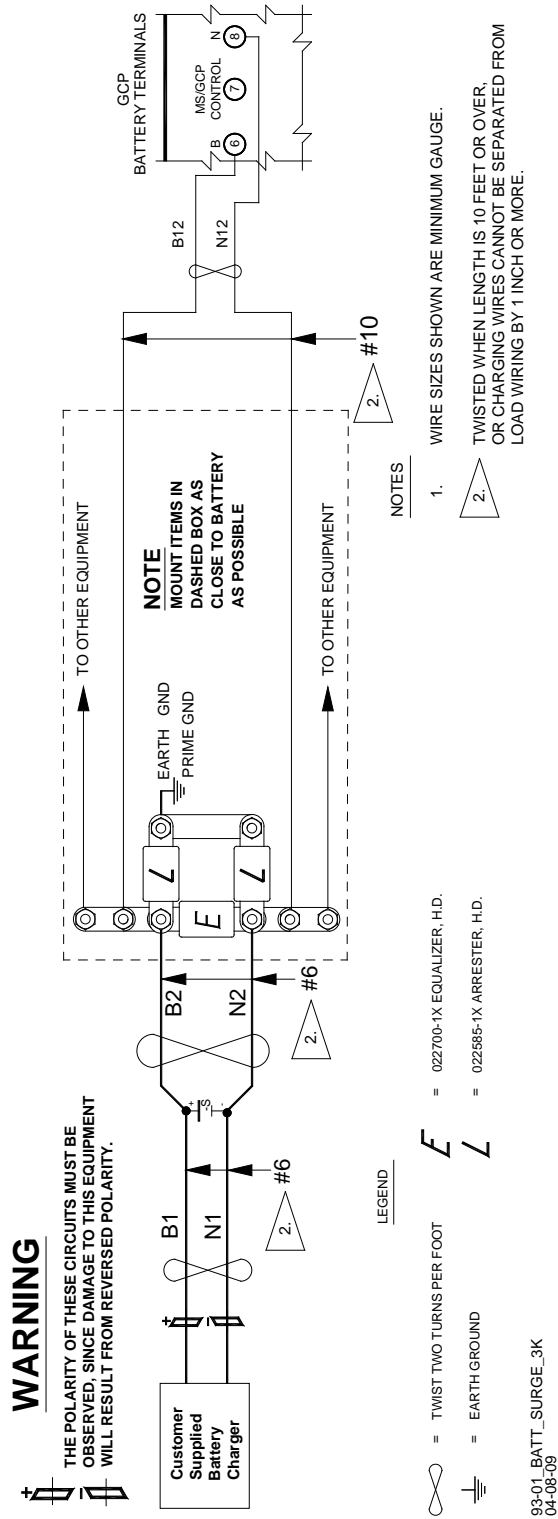
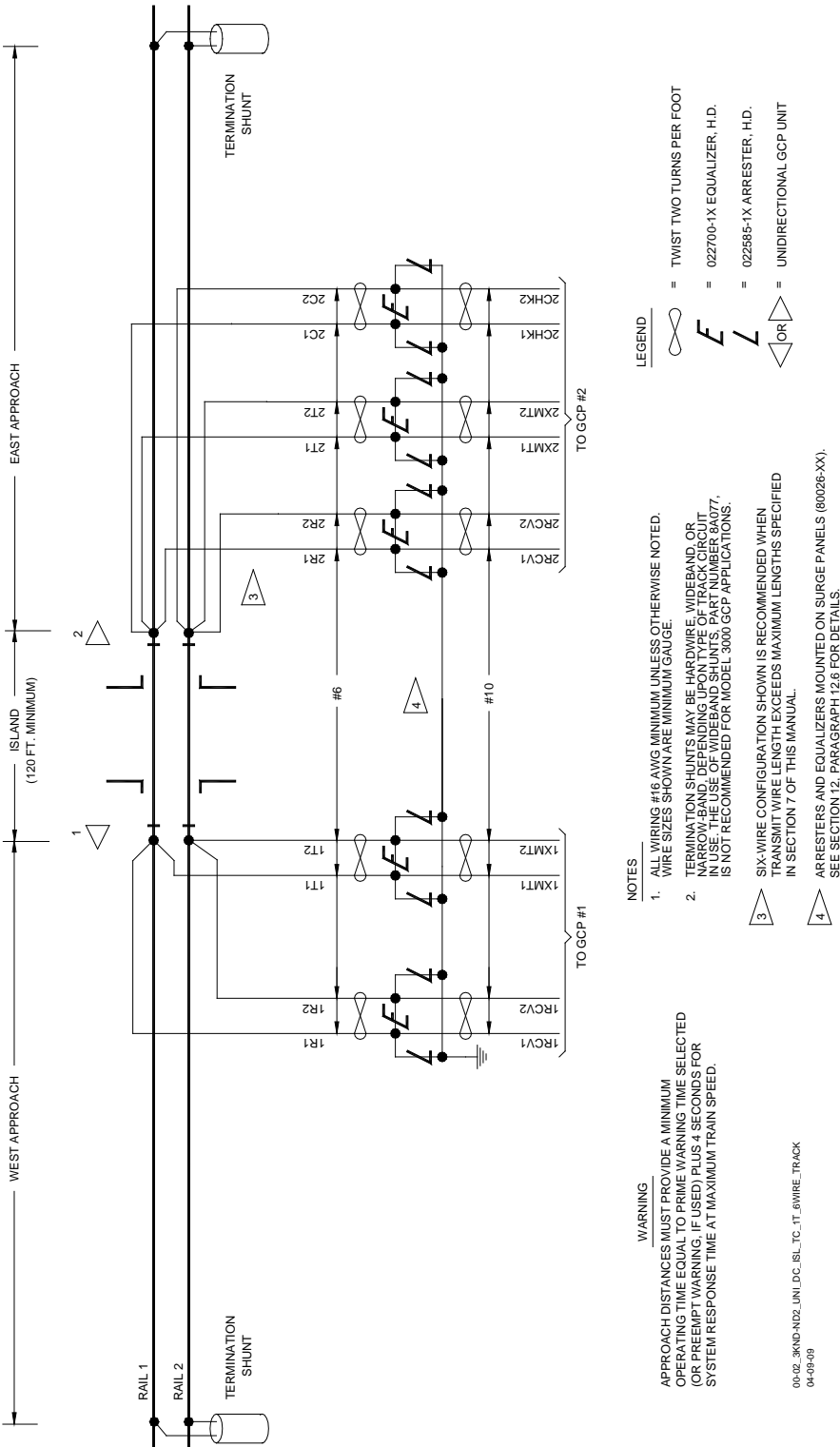


Figure 15-1:
Recommended Surge Suppression Wiring for Model 3000/3000D2 GCP



LEGEND

- = TWIST TWO TURNS PER FOOT
- = 022700-1X EQUALIZER, H.D.
- = 022585-1X ARRESTER, H.D.
- = UNIDIRECTIONAL GCP UNIT

NOTES

1. ALL WIRING #16 AVG MINIMUM UNLESS OTHERWISE NOTED. WIRE SIZES SHOWN ARE MINIMUM GAUGE.
2. TERMINATION SHUNTS MAY BE HARDWIRE, WIDEBAND, OR IN USE. THE USE OF WIDEBAND SHUNTS, PART NUMBER BA077, IS NOT RECOMMENDED FOR MODEL 3000 GCP APPLICATIONS.
3. SIX-WIRE CONFIGURATION SHOWN IS RECOMMENDED WHEN TRANSMIT WIRE LENGTH EXCEEDS MAXIMUM LENGTHS SPECIFIED IN SECTION 7 OF THIS MANUAL.
4. ARRESTERS AND EQUALIZERS MOUNTED ON SURGE PANELS (80026-XX). SEE SECTION 12, PARAGRAPH 12.6 FOR DETAILS.

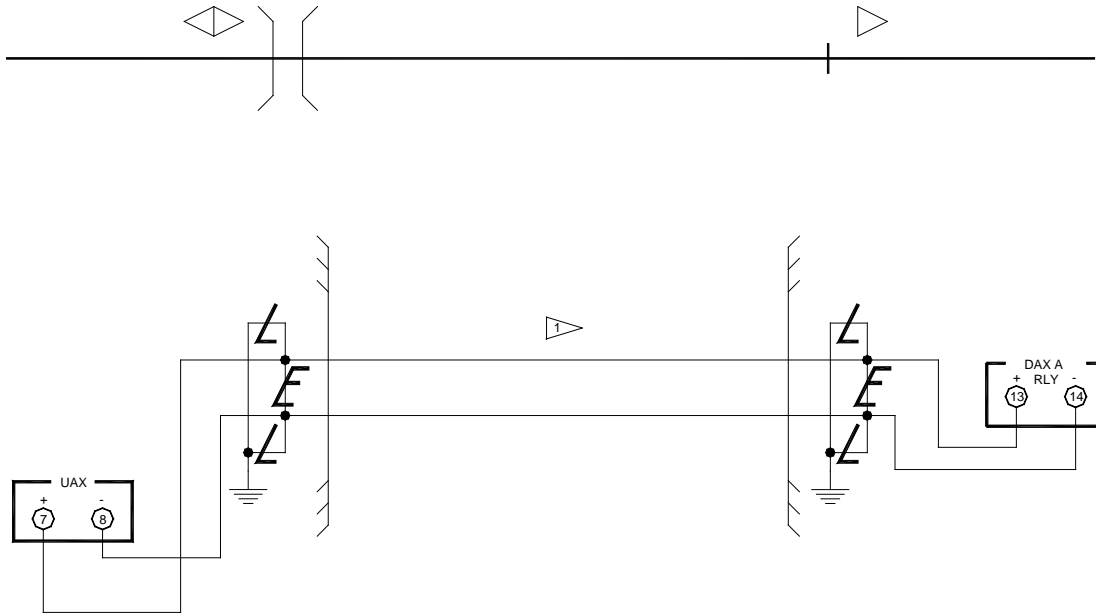
WARNING

APPROACH DISTANCES MUST PROVIDE A MINIMUM OPERATING TIME EQUAL TO PRIME WARNING TIME SELECTED (OR PREEMPT WARNING, IF USED) PLUS 4 SECONDS FOR SYSTEM RESPONSE TIME AT MAXIMUM TRAIN SPEED.

00402_3000-N02_LIN_DC_ISL_TC_IT_6WIRE_TRACK
04-09-09

Figure 15-2:
Typical Model 3000 GCP Surge Protection, Unidirectional Application With DC Island Track Circuit, One Track, Six Wire Hookup (Also Applies To Bidirectional Installations)

SURGE PROTECTION



NOTES

1 ARRESTERS AND EQUALIZERS CAN BE MOUNTED ON SURGE PANELS (80026-XX). SEE SECTION XII, PARAGRAPH 12.16 FOR DETAILS.

LEGEND

- L = 022585-1X ARRESTER, H.D.
- E = 022700-1X EQUALIZER, H.D.

FILE: 300015-3

Figure 15-3:
Typical Model 3000/3000D2 Surge Protection, DAX-UAX
Interconnections, Line Wire or Underground Wire