

Contents

Features and Benefits	6-3	WL Catalogue Numbering Overview	6-24
Breaker Assembly View	6-4	UL 489 Ratings	6-25
Product Overview	6-5	Ratings for UL 489	6-25
Draw-out Cradle Assembly View	6-6	Ratings for UL 489 (non-automatic)	6-26
Electronic Trip Units (ETUs)	6-7	UL 489 Assembled Breaker Catalogue Number	6-27
ETU Models and features	6-8	Interrupting Rating, Frame Size, Breaker Type and Frame Rating	6-27
ETU Communication	6-8	Rating Plug	6-28
ETU Metering function	6-9	Electric Trip Unit	6-28
Alarm Parameters	6-10	Bell Alarm, Ready-to-close Contacts	6-29
Extended Relaying	6-10	Shunt Trip	6-29
Function Overview of the ETU	6-11	Undervoltage Release	6-30
Factory Installed Options	6-13	Charging Motor, Motor Switch, Operations Counter	6-30
Ground Fault Module	6-13	Close Coil, Power Metering and Communications	6-31
Key Lock-out	6-13	Breaker Locks	6-31
Operation Counter	6-13	Miscellaneous Options	6-31
Auxiliary Contacts	6-13	UL 489 Assembled Breaker Catalogue Number (non-automatic)	6-32
Breaker Status Sensor (BSS)	6-13	Breaking Capacity, Frame Size, Switch Type and Frame Rating	6-32
Bell Alarm Contact and Reset Coil	6-14	Ready-to-close Auxiliary Contacts	6-32
Racking Handle Key Lock	6-14	Shunt Trip	6-33
Breaker Push-button Locks	6-14	Undervoltage Release	6-33
Close Coil	6-14	Charging Motor Switch and Operation Counter	6-34
Spring Charging Handle Lock	6-15	Close Coil Communications	6-34
Rating Plugs	6-15	Switch Locks	6-35
Ready-to-close Contact	6-15	Miscellaneous Options	6-35
Shunt Trip	6-15	UL 489 Accessories	6-36
Shunt Trip (continuous duty)	6-15	External Breaker Accessories	6-36
Status Contact	6-16	UL 489 Cradle Catalogue Numbers	6-37
Spring Charging Motor	6-16	UL 489 Cradle Accessories	6-39
Undervoltage Release	6-16	UL 1066 Ratings	6-40
Secondary Disconnect	6-17	Ratings for UL 1066	6-40
Isolation Shutters	6-17	Ratings for UL 1066 (non-automatic)	6-41
PROFIBUS or MODBUS Communications	6-17	UL 1066 Assembled Breaker Catalogue Number	6-42
Dual Key Breaker Locking	6-17	Interrupting Rating, Frame size, Breaker type and Frame Rating	6-42
Cradle Accessories and Options	6-18	Rating Plug	6-43
Arc Chute Cover	6-18	Electronic Trip Units	6-43
TOC (truck operated contacts)	6-18	Bell Alarm, Auxiliary Contacts	6-44
MOC (mechanism operated contacts)	6-18	Shunt Trip	6-44
Accessories	6-19	Undervoltage Release	6-45
Communication Power Supplies	6-19	Charging Motor	6-45
Handheld Test Device	6-19	Close Coil Power Metering and Communications	6-46
Breaker Display Adapter (BDA)	6-19	Breaker Locks	6-46
Mechanical Breaker Interlocks	6-19	Miscellaneous Options	6-46
Metering Current Transformer – 3-Phase Window	6-20	UL 1066 Non-automatic Assembled Breaker Catalogue Numbers	6-47
Metering Current Transformer – Single Phase	6-20	Breaking Capacity, Frame Size, Switch Type and Frame Rating	6-47
Neutral Current Sensor – 4-Wire Residual	6-20	Auxiliary Contacts	6-48
Breaker Door Cover	6-21	Shunt Trip	6-48
Door Sealing Frame	6-21	Undervoltage Release	6-48
Breaker Lifting Device	6-21	Charging Motor, Motor Switch, Operations Counter	6-49
Remote Breaker Racking Device	6-21	Close Coil, Communications	6-49
Breaker Hoist	6-21	Switch Locks	6-50
CubicleBus Modules	6-22	Miscellaneous Options	6-50
Digital Input Module	6-22		
ZSI Module	6-22		
Analog Output Module	6-22		
Pre-assembled CubicleBus Communication Cables	6-22		
Fixed-Mounted Breaker Bus Connectors	6-23		
Primary lug connector kits	6-23		

Contents

UL 1066 Breaker External Accessories	6-50	Options and Accessories	6-117
UL 1066 Cradle Catalogue Numbers	6-51	Mushroom Head Emergency Open Button	
UL 1066 Accessories	6-52	Door Sealing Frame	
Secondary Terminal Assignments	6-53	Plexiglass Breaker Cover	
General Wiring Schematic	6-54	Breaker Lifting Device	
Ground Fault Setting	6-56	Breaker Manual Charging Handle Replacement	
Metering Voltage Details	6-57	Breaker Shaft Extension	
UL 489 Fixed Breaker Dimensions	6-58	Breaker Maintenance Grease	
UL 489 Draw-out Breaker Dimensions	6-74	Breaker Replacement Feet	
UL 489 Door Sealing Frame Dimensions	6-88	WL Circuit Breaker Certified Test Report	
UI 1066 Draw-out Breaker Dimensions	6-89	Wire for N + GF CTs from X8.11 & 12 to Electronic Trip	
UL 1066 Draw-out Fuse Carriage Dimensions	6-90	Cubicle-bus Internal Wiring	
UL 1066 Door Sealing Frame Dimensions	6-102	Return to Factory Shipping Cartons for Breaker Only	
UL 1066 Draw-out Dimensions	6-103	Communication Components	6-118
Spare/Replacement Parts		Breaker Communications Module	
Trip Unit Options	6-104	Breaker Status Sensor	
Rating Plugs	6-104	External I/O CubicleBus Module	
Trip Unit Test Equipment	6-105	Cables for CubicleBus Modules	
24V DC Power Supply	6-105	External Communications Devices	
Draw-out Cradle Assembly	6-106	Technical Support Literature	
Secondary Disconnects	6-106	Typical Certified Test Report	
Stationary Primary Bus-bar Disconnect Terminals	6-107	Quick Reference Guide	
Cradle Arc Chute Cover	6-107	Ratings for 4 Pole UL 1066 (ANSI C37) Circuit Breakers	
MOC (mechanism operated aux. contacts)	6-107	Frame size 2	6-122
TOC (truck operated aux. contacts)	6-107	Frame size 3	6-123
Isolation Shutters	6-107	Ratings for UL 1066 Non-automatic switches	6-123
Locking Devices	6-108	UL 1066 Listed Catalogue Number	6-124
Mechanical Interlock Devices	6-108	Interrupting rating, frame size, breaker type and frame rating	
Metering CT Units	6-109	Rating Plug and Electronic Trip Units (ETU)	6-125
3-Phase Metering CTs	6-109	Bell alarm, breaker ready-to-close, auxiliary contacts	6-126
Single Phase Metering CTs	6-109	UL 1066 Listed Non-automatic Catalog Number	
Ground Fault and Current Sensors	6-110	Undervoltage Release (with or without time delay) or 2nd Shunt Trip	6-127
Circuit Breaker Accessories	6-111	Charging Motor, Motor switch, Operations Counter	6-127
Shunt Trip Releases	6-111	Close Coil, Power Metering and Communications	6-128
Auxiliary Switches	6-111	Breaking Capacity, Frame Size, Switch Type and Frame Rating	6-129
Bell Alarm Switches	6-111	Breaker Ready-to-close Auxiliary Contacts	6-130
Ready-to-close switch	6-111	Shunt Trip	6-130
Operation Counter	6-111	Undervoltage Release (with or without time delay) or 2nd Shunt Trip	6-130
Undervoltage Trip Release	6-112	Charging Motor, Motor Switch, Operations Counter	6-131
Signal Contractor for UV Trip	6-112	Close Coil, Communications	6-131
Closing Coil	6-112	Switch Locks	6-132
Spring Charging Motor	6-113	Miscellaneous Options	6-132
UL 1066 Internal Contact Replacement Kit	6-113	UL 1066 Fixed Mount Breaker Vertical Connector Kits	6-132
Internal Phase Sensor	6-113	Interrupting Rating, Frame Size and Frame Rating	6-133
UL1066 Circuit Breaker Arc Chute Replacement Kit	6-113	Arc Chute Cover	6-134
Circuit Breaker Finger Cluster Replacement Kit	6-114	Door Locks and Mechanical	6-134
Circuit Breaker Bus Connectors (fixed mounted)	6-114	Mechanism Operated Contacts (MOCs)	6-134
Circuit Breaker Fix Mount Optional Metric Hardware	6-114	Connector and Heater Options	6-134
Options and accessories	6-115	Frame Sizes / Dimension Drawings	6-135
Locking devices/sealing caps & padlocking provisions	6-115		
Breaker locking devices	6-116		
Fuse Kits	6-116		
WL Fuse Replacement Kits	6-116		

WL Circuit Breaker

Introduction

Businesses are becoming increasingly more intelligent about the way they consume energy. Industrial and Commercial energy consumers are continuously looking for practical and efficient methods of measuring their energy usage while simultaneously ensuring any possible downtime is minimized. At Siemens we understand those needs and we have developed products and solutions to help energy consumers achieve their goals.

One of our solutions begins with our world-class WL Circuit Breakers. The WL line-up of breakers developed by Siemens combines decades of patented circuit breaker protection experience with the latest technology in circuit breaker performance and communication.

A good example of our innovative technology is, Dynamic Arc-Flash Sentry® (DAS). DAS is a solution that allows users the ability to automatically lower the down-stream available fault current when facility personnel are nearby the electrical equipment. Helping our customers provide a safer work-place environment is an important part to our overall solutions.

Other valuable aspects that complement our solutions are the WL circuit breaker's ability to gather energy and environmental data and send it to a central or remote monitoring network system. You'll find these capabilities and more when you take a closer look at WL circuit breakers features within this guide.

WL Circuit Breaker Features and Benefits

- 3 frame sizes: Three frame sizes that cover a wide range of continuous current ratings allow for flexible exchange of breakers to other compartments and reducing the footprint of the breaker enclosures.
- Ready-to-close indication: Built-in check points of the breakers mechanical operator provide an additional layer of safety and external controls by inhibiting the breaker from closing until certain conditions are satisfied.
- 100% rating: All model breakers are designed for continuous operation at their maximum current ratings without de-rating the frame.
- High-efficiency: Low loss of energy flowing through the breaker reduces the operating costs.
- Bi-directional feed: Top or bottom supply feed without any hardware configuration changes.
- Rogowski coil sensing: Full range sensing without tap terminals or exchanging sensors to match load change requirements.
- Modular trip unit: Upgrading to a higher or lower current rating, adding ground fault, power monitoring or communication is cost effective and expandable using separately available modules.
- **Common accessories:**
Interchangeable accessories for all frame sizes makes upgrading easy and readily available.

Overview

Applications

The WL line of power breakers are protecting electrical distribution applications like waste water treatment, industrial plants, hospitals, transportation systems and data centers just to name a few. Yes, mission critical applications trust the Siemens WL circuit breakers to operate safe and reliably. The compact modular design provides higher power density in a section or line-up of distribution gear. Components like spring-charging motor, shunt trips, and trip units are common across the entire line of breakers. That allows users the ability to stock fewer spare parts or exchange options if necessary. Common options and accessories also make learning how to order, maintain and operate the WL much easier than most breakers on the market today.

WL circuit breakers are manufactured and performance tested to comply with UL489 and UL1066 standards for listed products.

UL/CSA 489 Listed type WL low voltage insulated case circuit breakers are generally intended to provide service entrance, feeder, and branch circuit protection in accordance with UL/CSA 489 Standard for Safety for Molded-Case Circuit Breakers, Molded-Case Switches, and Circuit-Breaker Enclosures. This versatile family of insulated case circuit breakers is acceptable for use within low-voltage switchboards (i.e. UL 891), low-voltage motor control centers (i.e. UL 845), and other types of industrial control equipment (i.e. UL 508 series). Certain options and maintenance capability may be limited in comparison to the UL1066 Listed circuit breakers. UL file numbers E231263, E236091 and E236299 apply.

UL 1066 Listed type WL low voltage power circuit breakers are generally intended to provide main and feeder circuit protection in accordance with UL1066 Standard for Safety for Low-Voltage AC and DC Power Circuit Breakers Used in Enclosures. Presently, there is not an equivalent CSA standard to UL 1066, and therefore these circuit breakers do not carry a CSA listing mark. These circuit breakers are constructed in compliance with ANSI/IEEE C37.13, and performance tested in accordance with ANSI C37.50. Throughout this document any reference to UL1066 will also mean ANSI C37 Certified. This versatile family of power circuit breakers is acceptable for use within low voltage switchgear (i.e. ANSI/IEEE C37.20.1, ANSI/IEEE C37.20.7, and UL 1558), low voltage switchboards (i.e. UL 891), low voltage motor control centers (i.e. UL 845), and other types of industrial control equipment (i.e. UL 508 series). Certain options and ratings may be limited in comparison to the UL/CSA 489 Listed circuit breakers. UL file numbers E240124, E240232, E240233 and E236299 apply. UL file numbers E231263, E236091 and E236299 apply.

WL Circuit Breaker

Breaker Assembly View

Overview

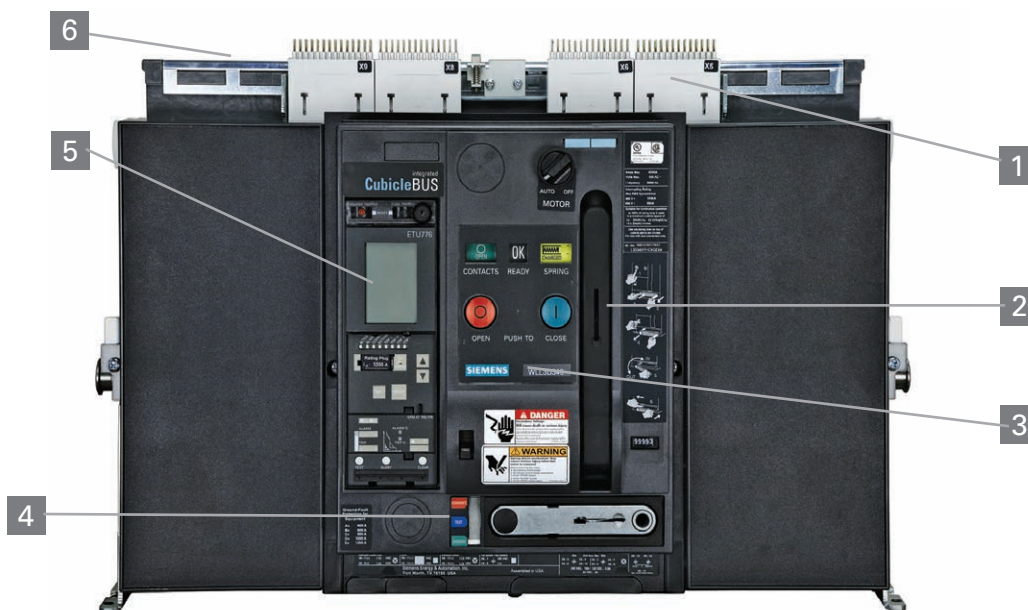

Exterior Breaker Features

- ① Secondary contacts
- ② Charging handle
- ③ Centralized operator panel
- ④ Integral racking handle with position indicator
- ⑤ Trip unit with LCD
- ⑥ Arc chutes

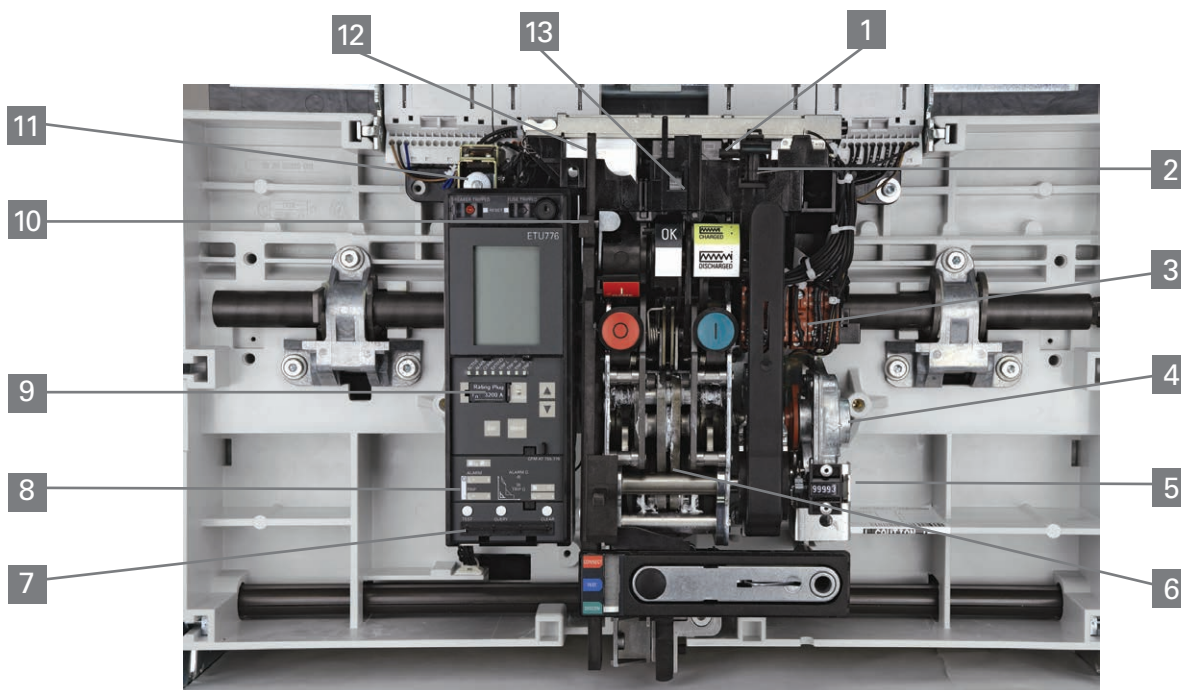

Interior Breaker Features

- ① Remote closing coil
- ② Second shunt trip or UV release
- ③ Auxiliary switch
- ④ Automatic charging motor
- ⑤ Operation counter
- ⑥ Operating mechanism
- ⑦ Electronic trip unit (ETU)
- ⑧ Optional ground fault module with alarm and trip functions
- ⑨ Interchangeable current rating plug
- ⑩ Breaker status sensor (BSS)
- ⑪ Bell alarm contact with remote reset
- ⑫ Shunt trip coil
- ⑬ Ready-to-close-contact

WL Circuit Breaker

Superior Individual Products for Low-voltage Power Distribution Systems

Overview

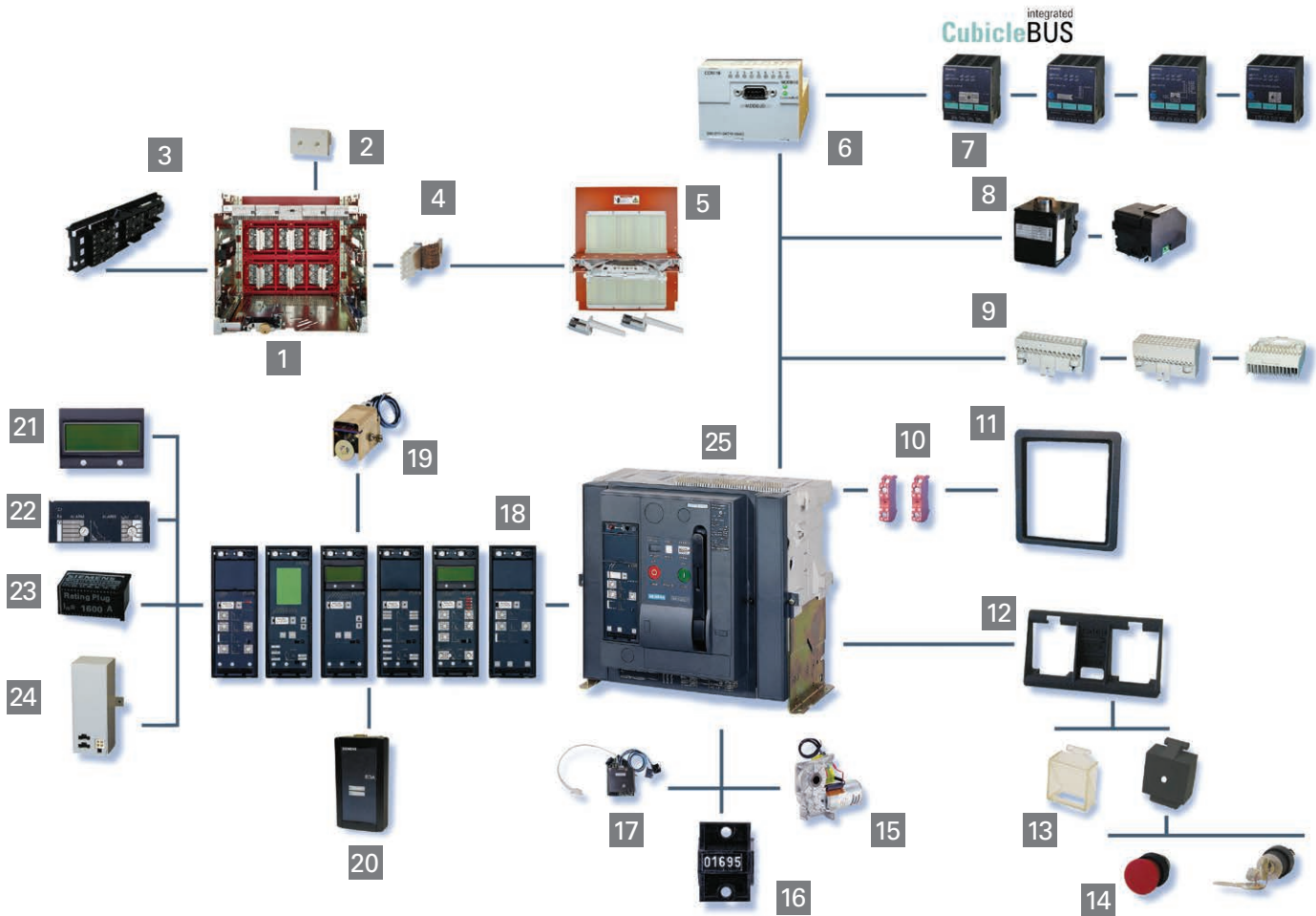

- ❶ Guide Frame (for drawout version only)
- ❷ Vertical to Horizontal BUS Connector
- ❸ Position Signaling Switch
- ❹ Breaker / Guide Frame Grounding Contact
- ❺ Shutter (locking)
- ❻ MODBUS or PROFIBUS Communications
- ❼ External CubicleBUS I/O Module
- ❽ Plug-In Open and Closed Solenoids
- ❾ Multiple Secondary Connections
- ❿ Auxiliary Switch Block
- ⓫ Door Sealing Frame
- ⓬ Interlocking Set Base Plate
- ⓭ Protective Cover for OPEN/CLOSE Buttons
- ⓮ Multiple Key Locking Accessories
- ⓯ Single Bolt Motor Operator Installation
- ⓰ Operations Counter
- ⓱ Breaker Status Sensor (BSS)
- ⓲ Complete Trip Unit Family
- ⓳ Remote Reset
- ⓴ Breaker Data Adapter (BDA) for Internet Connection
- ⓵ Multi Angle LCD Module
- ⓶ Ground Fault Protection Module
- ⓷ Rating Plug
- ⓸ Metering Function (+ wave forms and harmonics)
- ⓹ Circuit Breaker

6
WL POWER
CIRCUIT BREAKERS

WL Circuit Breaker

Draw-out Cradle Assembly View

Overview

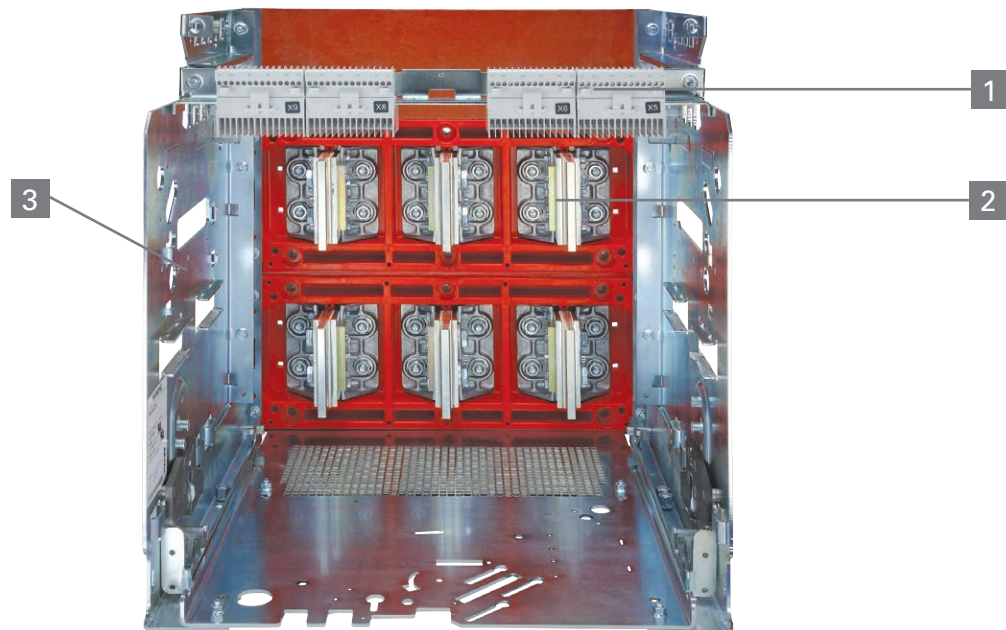

Standard cradle

- ❶ Stationary secondary disconnect
- ❷ Primary disconnects
- ❸ Cradle frame assembly for draw-out breakers

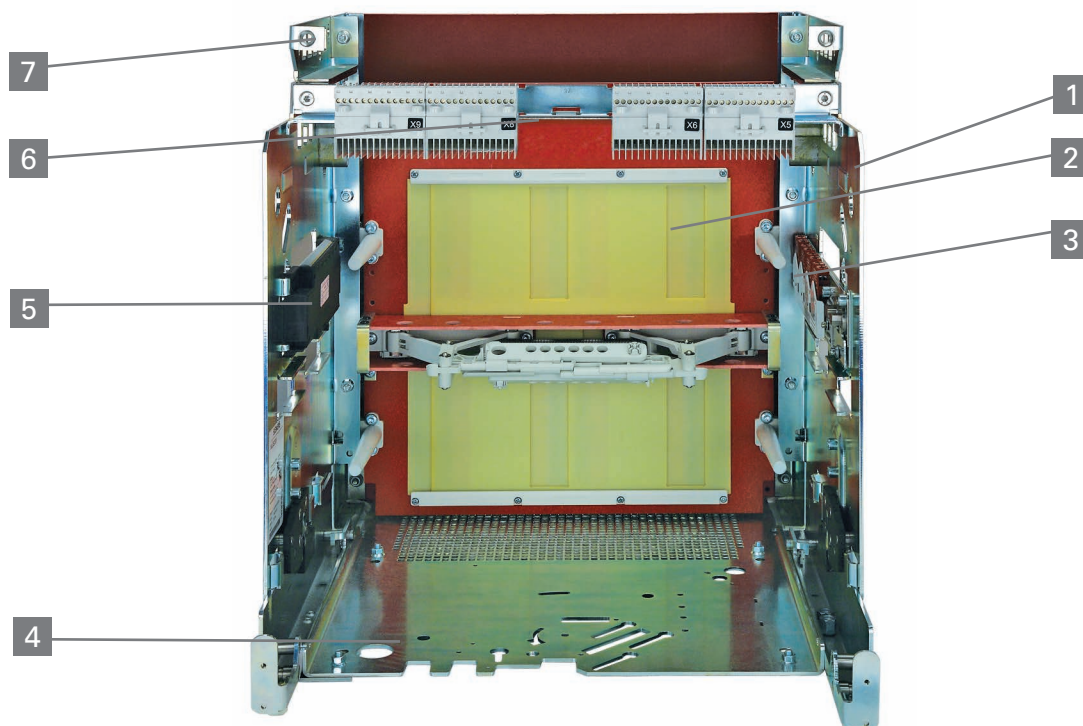

Cradle accessories

- ❶ Mechanical interlock (not shown)
- ❷ Isolation shutters
- ❸ Mechanism operated contact switches (MOC)
- ❹ Dual key-lock location
- ❺ Breaker position switches (TOC)
- ❻ Communication module location (COM 16 or COM 15)
- ❼ Optional arc chute cover (not shown)

WL Circuit Breaker

Electronic Trip Unit (ETU)

General

Power system protection is necessary to treat common types of abnormal occurrences, such as overloads or faults that can lead to electrical power system failure.

The methods for detecting and clearing such abnormalities and restore to normal operation is an engineered technique. Adequate protection requires constant measurements of certain system quantities, such as voltages and currents, comparing those system quantities, or some combination of the quantities, to a threshold setting computed by a systems engineer and set into an electronic trip unit like those available on the WL breakers. It's equally important for power system protection to perform under normal operating conditions. If the above thresholds are set too low the power may be interrupted unnecessarily causing loss of productivity or safety provisions.

The WL circuit breaker offers a practical means of setting power system protection through vast selectivity available in its Electronic Trip Unit (ETU). WL ETUs have a wide range of protective settings for implementing simple or complex coordination schemes and configuring reliable system protection.

ETU Enhanced Features

- **Extended Instantaneous Protection (EIP):** Allows the entire range of WL ampacities to be applied at the withstand rating of the breaker with minus 0% tolerance; that means no instantaneous override whatsoever. EIP further enables the circuit breaker to be applied up to the full interrupting rating of the breaker on systems where the available fault current exceeds the withstand rating, even with LS-only trip units.
- **Dynamic Arc-Flash Sentry (DAS):** Allows you the ability to execute a faster coordinated trip condition should an arc fault event occur while personnel are within the arc flash boundary. When the presence of personnel is no longer in the arc flash boundary, DAS will default back to maintaining your selective trip coordination through time delay functions. This is like toggling between two trip units on one breaker. DAS can be activated by a simple contact closer, so a wide range of activation devices can be used to enable DAS.
- **Selectable I⁴t:** ETU745 and 776 make it possible to switch over from an I²t to an I⁴t inverse-time function for overload protection. This selectivity increases optimization of coordinated overload protection when overload fuse protection is also provided.

ETU Basic Functions

Long-time trip

The long-time delay adjustment is used to set the tripping delay of the circuit breaker based on the magnitude of the overcurrent condition (6 times I_r). For example if the rating plug is 2000 amps and the long-time delay is set to 10 seconds, a fault current of 12,000 amps (6 x 2000) will cause the breaker to trip after 10 seconds. Long-time is an inverse of I²t ramp function. This means the higher the current, the shorter the time the circuit breaker will remain closed. An Alarm LED indicator will flash during the delay period and a separate "Trip L" indicator may turn on if the breaker trips on long-time function.

Short-time trip

The short-time pickup adjustment is used to set the level of high current the breaker will carry for a short period of time without tripping. This adjustment is set in multiples of the value of the rating plug (I_r). Together with the short-time delay, this adjustment allows downstream breakers time to clear short circuit faults without tripping upstream breakers. Short-time delay is used to set the time interval the breaker will wait before responding to the current value selected by short-time pickup. There are two modes of operation: fixed and I²t. The I²t delay has the characteristic of being inversely proportional to the square of the magnitude of the current. This means higher overcurrent conditions have shorter delays. An Alarm LED indicator may flash during the delay period and a separate "Trip S" indicator will turn on if the breaker trips on short-time function.

Instantaneous trip

The instantaneous pickup adjustment is used to set the current level at which the breaker will trip without an intentional time delay. Non-delayed tripping as a result of severe over-current minimizes potential damage to the electrical system and equipment.

Ground fault

The ground fault pickup adjustment is used to set the level of ground current at which circuit interruption will be initiated.

Together with ground fault delay, this adjustment allows selective tripping between main and feeder or downstream breakers.

The ground fault delay adjustment is used to set the time interval (in seconds) the breaker will wait before responding once the ground fault pickup level has been reached. The available ground fault delay settings available are: inverse time (I²t) or fixed delay.

WL Circuit Breaker

Electronic Trip Unit (ETU)

Selection



ETU Models and Features

Features and Characteristics	ETU745	ETU748	ETU776
Long-time overcurrent protection (L)	X	X	X
Short-time delayed overcurrent protection (S)	X	X	X
Instantaneous overcurrent protection (I)	X	X	X
Neutral conductor protection (N)	X	X	X
Ground fault protection (G)	O	O	O
Selectable neutral protection	X	X	X
Defeatable short-time protection	X	–	X
Defeatable instantaneous protection	X	–	X
Selectable thermal memory	X	–	X
Zone selective interlocking	X	–	X
Selectable I2t or fixed short-time delay	X	X	X
Adjustable instantaneous pick-up	X	X	X
Selectable I2t or I4t long-time delay	X	X	X
Adjustable short-time delay and pick-up	X	X	X
Selectable and adjustable neutral protection	X	X	X
Dual protective setting capability	–	–	X
Dynamic arc-flash sentry (DAS)	–	–	X
Extended instantaneous protection (EIP)	–	–	X
Parameterization by rotary switches	–	–	
Parameterization by communication (absolute values)	–	–	X
Parameterization by menu/keypad (absolute values)	–	–	X
Remote parameterization of the alarm functions	–	–	X
Remote parameterization of the relay functions	–	–	X
Alphanumeric display	O	O	X
Graphical display	–	–	X
Power metering function	O	O	O
Communication via PROFIBUS-DP	O	O	O
Communication via the MODBUS	O	O	O
Communication via the Ethernet (BDA)	O	O	O

(X) = Standard Feature, (O) = Optional Feature

ETU Communication

The ETU uses a Siemens proprietary communication network called CubicleBus. The CubicleBus network ensures all Siemens devices are able to transmit data reliably and efficiently. The ETU can not be connected directly any other network so the use of converters are necessary to allow communication between the ETU and the outside world. The WL has three types of converters to allow communication between the ETU and computer type equipment. The three converts are:

- PROFIBUS (COM15)
- ModBus (COM16)
- HTML or TCP/IP (BDA)

The WL PROFIBUS converter is model 'COM15.' The COM15 device acts as an interface between the WL breaker and the information environment. A joint

device master file (GSD) can be used for integrating WL circuit breakers in a PROFIBUS-DP network. The advantage of this joint communication profile is that the same software can be used for automation, monitoring and control systems.

The WL ModBus converter is model 'COM16'. The COM16 device enables the WL breaker to be connected to any Modbus master network. Universal Modbus mapping can be used to allow custom monitoring and controls with a centralized monitoring system. The Modbus port is configured for RS485 connectivity and can easily be daisy-chained to several WL breakers to create a serial-network suitable for connecting to a LAN or WAN network.

The WL HTML or TCP/IP converter is called 'BDA.' The BDA is a microcomputer with an embedded Linux operating system running a web server application. The HTML pages and JAVA codes are stored internal to the BDA and can be accessed with an external PC web browser. All of the viewable web pages are stored in the BDA. The BDA communicates to the ETU through a front connected ribbon-cable. The PC accesses the BDA through an integral DB-9 serial port or an RJ45 Ethernet port.

All three converters require a 24VDC Class 2 power supply. See External Accessories for more information on available power supplies.

WL Circuit Breaker

Electronic Trip Unit (ETU)

Selection

Power metering function

In addition to excellent protection capabilities, the WL ETU has unparalleled power metering functionality. True RMS current sensing for metering is obtained from the same current sensors used for overload protection. ETU power metering can measure the following:

Measured Value	Value Range	Accuracy
Currents Ia, Ib, Ic, In	30 ... 8000A	± 1%
Ground-fault current Ig (measure with external Gnd transformer)	100 ... 1200A	± 5%
Line-to-line voltages Vab, Vbc, Vca	80 ... 120% Vn	± 1%
Line-to-neutral voltages Van, Vbn, Vcn	80 ... 120% Vn	± 1%
Average value of phase-to-phase voltages V L-L AVG	80 ... 120% Vn	± 1%
Apparent power kVA per phase	13 ... 8000kVA	± 2%
Total apparent power KVA	13 ... 24000kVA	± 2%
Active power kW per phase	-8000 ... 8000kW	± 3% (power factor > 0.6)
Total active power kW total	-24000 ... 24000kVA	± 3% (power factor > 0.6)
Reactive power kvar	-6400 ... 6400kvar	± 4% (power factor > 0.6)
Total reactive power kvar	-20000 ... 20000kvar	± 4% (power factor > 0.6)
Power factor per phase	-0.6 ... 1 ... 0.6	± 0.04
Power factor total	-0.6 ... 1 ... 0.6	± 0.04
Demand of currents Ia, Ib, Ic	30 ... 8000A	± 1%
Average demand of 3-phase current	30 ... 8000A	± 1%
Demand kW per phase	13 ... 8000kW	± 3% (power factor > 0.6)
kW demand 3-phase active power kW total	13 ... 8000kW	± 3% (power factor > 0.6)
kVA demand kVA total	13 ... 8000kVA	± 2%
kVAR demand kVAR per phase	13 ... 8000kVA	± 2%
kVAR demand total	-24000 ... 24000kvar	± 4% (power factor > 0.6)
kWhr imported	1 ... 10000MWh	± 2%
kWhr exported	1 ... 10000MWh	± 2%
kVARh imported	1 ... 10000Mvarh	± 4%
kVARh exported	1 ... 10000Mvarh	± 4%
Frequency	15 ... 440 Hz	± 0.1 Hz
Total harmonic distortions for current and voltage	2 ... 100%	± 3% from the meas. range up to the 29th harmonic
Phase unbalance for current and voltage	2 ... 150%	± 1%

Potential transformers (PTs) are required to step down the supply voltage to a level that is suitable for local input connection to the breaker. PTs must be wired to the secondary connections of the breaker and configured for three-phase, three-wire or three-phase, four-wire supply system. The measured values can be sent to a central database for future power analysis or consumption reports.

Metering is not field installable – it must be configured in the initial breaker purchase.

Event log

The event log is very extensive. Information regarding the list of events can be found in the WL operation manual or communication guide. Some of the event log categories are:

- Warnings
- Trip Logs
- Set-points
- Maintenance Detail
- CubicleBus Conditions
- Waveform Displays

WL Circuit Breaker

Electronic Trip Unit (ETU)

Selection

Alarm Parameters

The metering function includes the following alarm set-point functions:

Alarm Function	Setting Range	Possible Delay
Overcurrent	3 ... 10000A	0 ... 255s
Overcurrent – ground fault	3 ... 10000A	0 ... 255s
Overcurrent – N-conductor	3 ... 10000A	0 ... 255s
Phase unbalance – current	5 ... 50%	0 ... 255s
Demand – current	3 ... 10000A	0 ... 255s
Total harmonic distortion – current	0 ... 50%	5 ... 255s
Undervoltage	100...1200V	0 ... 255s
Overvoltage	200...1200V	0 ... 255s
Phase unbalance – voltage	5 ... 50%	0 ... 255s
Total harmonic distortion – voltage	0 ... 50%	5 ... 255s
Crest factor	0.01 ... 25.5%	0 ... 255s
Form factor	0.01 ... 25.5%	0 ... 255s
Active power in normal direction	1 ... 10000kW	0 ... 255s
Active power in reverse direction	1 ... 10000kW	0 ... 255s
Leading power factor	-0.999 ... 1	0 ... 255s
Lagging power factor	-0.999 ... 1	0 ... 255s
Demand – active power	1 ... 10000kW	0 ... 255s
Apparent power	1 ... 10000kVA	0 ... 255s
Reactive power in normal direction	1 ... 10000kvar	0 ... 255s
Reactive power in reverse direction	1 ... 10000kvar	0 ... 255s
Demand – apparent power	1 ... 10000kVA	0 ... 255s
Demand – reactive power	1 ... 10000kvar	0 ... 255s
Under frequency	40 ... 70Hz	0 ... 255s
Over frequency	40 ... 70Hz	0 ... 255s

Extended Relaying

Protective relays included with the metering function can monitor the following criteria and initiate a trip if the values are exceeded.

Protective Relay Function	ANSI Device Number	Setting Range	Possible Delay
Current unbalance	46	5 ... 50%	1 ... 15s
Total harmonic distortion - current	81 THDC	0 ... 50%	5 ... 15s
Voltage unbalance	47	5 ... 50%	1 ... 15s
Undervoltage	27	100 ... 1100V	1 ... 15s
Overvoltage	59	200 ... 1200V	1 ... 15s
Total harmonic distortion - voltage	81 THDV	0 ... 50%	5 ... 15s
Direction of phase rotation	47N	–	–
Active power in normal direction	32	1 ... 10000kW	1 ... 15s
Active power in reverse direction	32R	1 ... 10000kW	1 ... 15s
Under frequency	81U	40 ... 70Hz	1 ... 15s
Over frequency	81O	40 ... 70Hz	1 ... 15s

WL Circuit Breaker

ETU Function

Overview

Basic Functions		ETU745
	Long-time overcurrent protection	✓
	Function can be disabled	–
	Setting range $I_R = I_n \times \dots$	0.4, 0.45, 0.5, 0.55, 0.6, 0.65, 0.7, 0.8, 0.9, 1
	Switch-selectable overload protection (I^2t or I^4t dependent function)	✓
	Setting range of time delay class t_R at I^2t (seconds)	✓
	Setting range of time delay t_R at I^4t (seconds)	2, 3.5, 5.5, 8, 10, 14, 17, 21, 25, 30
	Thermal memory	✓
	Phase loss sensitivity	Set $t_{sd} = 20$ ms (M)
	Neutral protection	✓
	Function can be disabled	✓ (via slide switch)
N-conductor setting range $I_N = I_n \times \dots$	0.5 ... 1	
	Short-time overcurrent protection	✓
	Function can be disabled	✓ (via rotary switch)
	Setting range $I_{sd} = I_n \times \dots$	0.02 (M), 0.1, 0.2, 0.3, 0.4, OFF
	Setting range of time delay t_{sd} , fixed (constant time in seconds)	0.02 (M), 0.1, 0.2, 0.3, 0.4, OFF
	Setting range of time delay I_{sd} at I^2t (seconds)	0.1, 0.2, 0.3, 0.4
Zone Selective Interlocking (ZSI) function	Per CubicleBUS module	
	Instantaneous overcurrent protection	✓
	Function can be disabled	✓
	Extended Instantaneous Protection	Instantaneous is active when disabled
	Setting range $I_I = I_n \times \dots$	1.5, 2.2, 3, 4, 6, 8, 10, 12, $0.8 \times I_{cw} = \text{Max.}$
	Ground fault protection[ⓐ]	○ (field installable module)
	Trip and alarm function	✓
	Detection of the ground fault current by residual summing method	✓
	Detection of the ground fault current by direct sensing method	✓
	Setting range of the I_g for trip	A, B, C, D, E (100 ... 1200A)
	Setting range of the I_g for alarm	A, B, C, D, E (100 ... 1200A)
	Setting range of the time delay t_g (fixed seconds)	0.1, 0.2, 0.3, 0.4, 0.5
	Setting range time delay t_g at I^2t	0.4, 0., 0.3, 0.4, 0.5
ZSI ground function	Per CubicleBUS module	

ⓐ Extended Instantaneous Protection (EIP) allows the WL breaker to be applied at the withstand rating of the breaker with minus 0% tolerance; that means no instantaneous override whatsoever. EIP further enables the circuit breaker to be applied up to the full instantaneous rating of the breaker on systems where the available fault current exceeds the withstand rating.
 ⓑ Ground Fault Module cannot be removed after installation.

✓ Available
 – Not available
 ○ Optional

WL Circuit Breaker

ETU Function

Overview

Basic Functions		ETU748	ETU776
	Long-time overcurrent protection	✓	✓
	Function can be disabled	–	–
	Setting range $I_R = I_n \times \dots$	0.4, 0.45, 0.5, 0.55, 0.6, 0.65, 0.7, 0.8, 0.9, 1	40-100% of I_n (Adjustable in Amps ^①)
	Switch-selectable overload protection (I^2t or I^4t dependent function)	✓	✓
	Setting range of time delay class t_R at I^2t (seconds)	2, 3.5, 5.5, 8, 10, 14, 17, 21, 25, 30	2...30 (step; 0.1s)
	Setting range of time delay t_R at I^4t (seconds)	1, 2, 3, 4, 5	1...5 (step; 0.1s)
	Thermal memory	✓ (via slide switch)	✓ (on/off via keypad or communications)
	Phase loss sensitivity	at $t_{sd} = 20$ ms (M)	✓ (on/off via keypad or communications)
	Neutral protection	✓ (via slide switch)	✓
	Function can be disabled	0.5 ... 1 OFF	✓ (on/off via keypad or communications)
N-conductor setting range $I_N = I_n \times \dots$	✓	0.5 ... 2 OFF	
	Short-time overcurrent protection	✓ (via rotary switch)	✓
	Function can be switched ON/OFF	1.25, 1.5, 2, 2.5, 3, 4, 6, 8, 10, 12	✓ (on/off via keypad or communications)
	Setting range $I_{sd} = I_n \times \dots$	✓ (via rotary switch)	1.25... 0.9 x $I_{cw} = \text{max.}$ (step: 10A)
	Setting range of time delay t_{sd} , fixed (seconds)	M, 0.1, 0.2, 0.3, 0.4	M, 0.08... 0.4, OFF (step: 0.001s)
	Switch-selectable short-time delay short-circuit protection (I^2t dependent function)	✓ (via rotary switch)	✓ (via keypad or communications)
	Setting range of time delay I_{sd} at I^2t (seconds)	0.1, 0.2, 0.3, 0.4	0.1... 0.4 (step 0.001s)
	Zone Selective Interlocking (ZSI) function	per CubicleBUS module	Per CubicleBUS module
	Instantaneous overcurrent protection^②	✓	✓
	Function can be disabled, Extended Instantaneous Protection is enabled when OFF	–	✓ (via keypad or communications)
	Setting range $I_i = I_n \times \dots$	$I_i = I_{cw} = \text{EIP}$	1.5 ... 0.8 x $I_{cs} = \text{Max OFF} = I_{cw} = \text{EIP}$
	Ground fault protection^③	○ (field installable module)	○ (field installable module)
	Trip and alarm function	✓	✓
	Detection of the ground fault current by residual summing method	✓	✓
	Detection of the ground fault current by direct sensing method	✓	✓
	Setting range of the I_g for trip	A, B, C, D, E	A... E (step: 1A)
	Setting range of the I_g for alarm	A, B, C, D, E	A... E (step: 1A)
	Setting range of the time delay t_g (seconds)	0.1, 0.2, 0.3, 0.4, 0.5	0.1...0.5 (step: 0.001s)
	Switch-selectable ground fault protection (I^2t / fixed)	✓	✓
	Setting range time delay t_g at I^2t	0.1, 0.2, 0.3, 0.4, 0.5	0.1...0.5 (step: 0.001s)
ZSI Ground Function	Per CubicleBUS module	Per CubicleBUS module	

① NOTE: ETU776 settings via WLBD, Modbus, or Profibus: 1A steps
Via ETU Keypad: Below 1000A: 10A steps
1000A-1600A: 50A steps
1600A-10000A: 100A steps
Above 10000A, 1000A steps

② Extended Instantaneous Protection (EIP) allows the WL breaker to be applied at the withstand rating of the breaker with minus 0% tolerance; that means no instantaneous override whatsoever. EIP further enables the circuit breaker to be applied up to the full instantaneous rating of the breaker on systems where the available fault current exceeds the withstand rating.

③ Ground Fault Module cannot be removed after installation.

④ NOTE: M = indicates phase loss sensitivity is enabled. LT pick-up reduced 80% when phase unbalance > 50%. ST = 20 ms
Key pad = Direct input at the trip unit.

✓ Available
– Not available
○ Optional

WL Circuit Breaker

Factory Installed Options^①

Characteristics

Breaker Mounted Options

Ground Fault Module

The ground fault module (GFM) is used to detect current flowing through the grounding conductors which may present a hazardous condition. The module can be field installed but can't be removed once installed. Residual sensing by phase vector summation or direct sensing can be selected on the module or via the setup of the ETU776. Ground fault modules may be ordered as alarm only or as alarm and trip. Alarm will provide a visual and communication notification. Alarm and trip model will trip the breaker in addition to alarm notification.

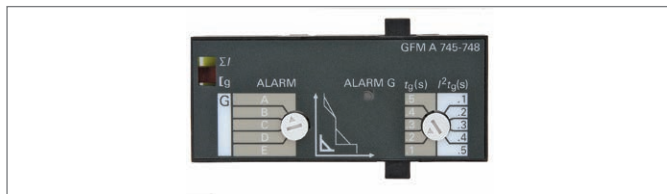

Key Lock-out

To lock the WL breaker in the "Open" position, an optional key-lock can be installed in the breaker. The key cylinder and lock-out assembly are mounted in the breaker and accessible through a knockout in the breaker front cover. The key is removable only when the breaker is locked open. If a custom, coordinated key/cylinder is required, order the lock provision-only. The lock cylinder and matched key must then be ordered separately from the respective lock manufacturer.

The compatible Kirk cylinder lock part number is C-900-301. The compatible Superior cylinder lock part number is C-900.



Operation Counter

For monitoring the number of breaker operations (open and close) a numerical operations counter is available. This counter is only suitable for breakers equipped with the spring-charging motor option. The counter mounts to the motor assembly and will register manual and electrical breaker operations. Counter is non-resettable up to 100,000 operations. Counter ships with available pre-service operations for field setting to zero.



^① See page 106 for field install part numbers.

Auxiliary Contacts

Auxiliary contacts can be used to provide interlocking control or remote indication of the breakers main contact position (open or closed breaker). The Normally Open (NO) contacts are open when the breakers main contacts are open. The Normally Closed (NC) contacts are closed when the breakers main contacts are open. The contacts are wired individually to the secondary disconnects for user connectivity. See breaker wiring diagram for supply terminal locations.

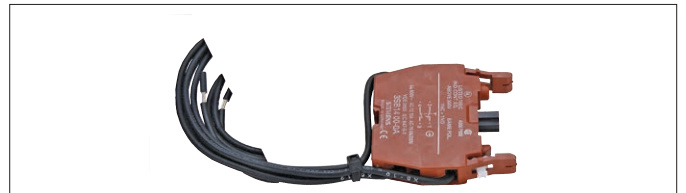

Available Contact Configurations		2NO and 2NC or 4NO and 4NC
AC Operation	Voltage	240VAC 50/60Hz
	Continuous Current	10A
	Making Current	30A
	Breaking Current	3A
DC Operation	Voltage	24, 125, 250V DC
	Continuous Current	5A
	Making Current	1.1A @ 24 or 125VDC, .55A @ 250VDC
	Breaking Current	1.1A @ 24 or 125VDC, .55A @ 250VDC

Breaker Status Sensor (BSS)

BSS is an integrated circuit device that measures the internal breaker temperature, monitors breaker main contact position (open or closed), bell alarm status, shunt trip status, breaker ready-to-close and closing spring charged status. All status conditions and information is transmitted through the CubicleBus network as real-time data. A COM16 (Modbus), COM15 (PROFIBUS) or a BDA (breaker display adapter) accessory can be used to export the BSS CubicleBus data to external computer or monitoring equipment. See breaker wiring diagram for supply terminal locations. Included with COM15 and COM16.



Operating Voltage	24V
Peak Inrush Current	110mA
Max. Continuous Current	40mA
Ambient Operation Temperature	-25 to 70°C

WL Circuit Breaker

Factory Installed Options^①

Characteristics

Bell Alarm Contact and Reset Coil

The bell alarm contacts are mechanically activated by the trip unit solenoid. If a breaker trip condition occurs, the bell alarm form-C contacts will change state closing or opening a user circuit wired to the secondary terminal block. The contacts can be locally reset to their original position by manually resetting the breaker trip button or through the use of a reset coil that resets the contacts remotely. See breaker wiring diagram for supply terminal locations. Non-automatic (manual) reset trip units can not be used with the reset coil option.



Breaker Push-Button Lock-outs

A finger or hand tool shroud option can be added to the breaker front cover to isolate the open and close buttons from unintentional use. Shrouds may be used in combination or like configuration.

To isolate the open and close buttons from unintentional use, transparent padlock covers can be installed in lieu of the shroud option. Two padlocks may be used with a latch diameter of 3/8 inch maximum (padlocks by others).



Available Contact Configurations	Coil Ratings	
	Remote	Voltage
Reset Coil	Continuous Current	5A
	Making Current	8A
AC Operation	Breaking Current	5A
	Voltage	24, 48, 125 or 250VDC
Reset Coil	Continuous Current	5A
	Making Current	0.4A @ 24, 48, 125VDC, 0.2A @ 250VDC
DC Operation	Breaking Current	0.4A @ 24, 48, 125VDC, 0.2A @ 250VDC

Close Coil

To remotely close the WL breaker, a close coil must be used with a momentary electrical source. Only one close coil can be used per breaker. Charging springs must be charged and breaker open prior to activating the close coil. See breaker wiring diagram for supply terminal location.



Racking Handle Key Lock

A draw-out breaker can be key locked (optional) or padlocked (standard not shown) in three racking positions; connect, test or disconnect. Key lock cylinders are available in Kirk or Superior types and uniquely keyed.

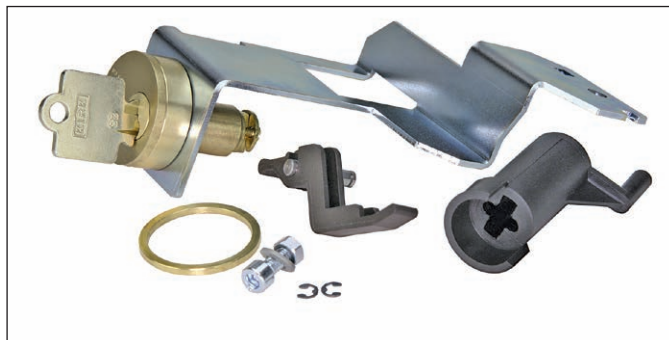

Close Coil	120VAC Range	104 - 127VAC
	240VAC Range	208 - 254
AC Operation	Power Consumption	120W for 50ms (5% duty cycle)
	Breaker closing time	50ms from point of signal
	24V DC	14 - 28V DC
	48V DC	28 - 56V DC
Close Coil	125V DC	70 - 140VDC
DC Operation	250V DC	140 - 280VDC
	Power Consumption	120W for 50ms (5% duty cycle)
	Breaker closing time	50ms from point of signal

① See page 6-106 for field install part numbers.

WL Circuit Breaker

Factory Installed Options^①

Characteristics

Spring Charging Handle Lock

An optional padlock provision to prevent manual charging of the closing springs can be installed on the breaker front cover. This provision does not prevent electric charging of the closing springs and the breaker can be mechanically closed if the closing spring is charged prior to padlocking the charging handle. One padlock may be used with a latch diameter of 3/8 inch maximum (padlock by others).



Rating Plugs

The rating plug is required to limit the downstream load current. Use of a rating plug that exceeds the breaker frame rating will result in a trip unit error and will trip the breaker automatically. Rating plugs are field interchangeable.



Ready-to-close Contact

In addition to the standard "ready-to-close" visual indicator on the WL breaker, an optional contact can be added to remotely monitor the ready-to-close conditions. Closing is ready if all of the following conditions are true:

- Closing spring-charged
- Breaker main contacts are open
- Mechanical lock-outs disabled
- Racking handle seated in stored position
- Electrical lock-outs disabled

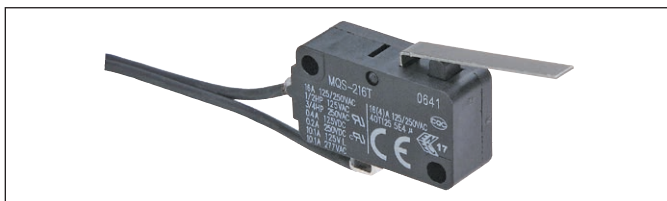

Ready-to-close contact	Voltage	125-240VAC, 125 -250VDC
	Continuous current	3A
	Making current	0.4A @24-125VDC, 5A @120-240VAC
	Breaking current	0.2A @24-125VDC, 3A @120-240VAC

Shunt Trip

The shunt trip opens the circuit breaker instantly when energized by a remote power source. An auxiliary contact is wired in series with the shunt trip to remove the current from the coil after the breaker is opened. Two shunt trip coils may be installed in a breaker if dual supply sources or control circuits are required. An optional status contact may be selected with the second shunt trip to provide a signaling condition that the shunt trip has been activated. Status contact not available with communication option. Status condition is sent via communication instead of contact.



Trip coil AC operation	120VAC range	104 - 127VAC
	240VAC range	208 - 254VAC
	Power consumption	120W for 50ms (5% duty cycle)
	Min. closing time	50ms from point of signal
Trip coil DC operation	24VDC range	14 - 28VDC
	48VDC range	28 - 56VDC
	125VDC range	70 - 140VDC
	250VDC range	140 - 280VDC
	Power consumption	120W for 50ms (5% duty cycle)
	Min. closing time	50ms from point of signal

Shunt Trip (continuous duty)

The continuous duty shunt trip is available for 100% duty cycle and can hold the WL breaker open during an electrical or manual "close breaker" attempt (i.e. lock-out). The continuous duty trip may be used in conjunction with a standard shunt trip solenoid for dual control. Not available for use with UL1066 Listed breakers.



Shunt Trip (interlock coil)	120 - 240 VAC range	85 - 110% of nominal
	24 - 250VDC range	70 - 126% or nominal
	Power consumption	15W / 15VA
	Min. shunt trip actuation	60 ms
	Opening time of breaker	80 ms
	Smallest fuse protection rating	1A

^① See page 6-85 for field install part numbers.

WL Circuit Breaker

Factory Installed Options^①

Characteristics

Status Contact

A status contact is a mechanical switch that is suitable for monitoring an undervoltage trip or second shunt trip coil position. The contact will be wired to the secondary contacts of the breaker for customer connections or wired to the Breaker Status Sensor (BSS) if communications is installed on the breaker. Contact is 1NO configured.



Signaling contact	Voltage	127 - 240VAC, 24 - 125VDC
	Continuous current	3A
	Making current	1A @24 - 125DVC, 5A @120 - 240VAC
	Breaking current	1A @24 - 125DVC, 3A @120 - 240VAC

Spring-charging Motor

The spring charging motor is used to automatically charge the breakers closing spring so the breaker is suitable for closing on command. Motor charging is typically used for remote breaker operation or as an alternative to local manual charging. The motor assembly can be easily installed in the field and includes an automatic cut-off switch which disconnects the current upon full charge of the closing spring mechanism.



Spring-charging motor	120 - 240VAC range	85 -110% of nominal
	24 - 240VDC range	70 - 126% of nominal
	Power consumption	110W
	Max. charging time	10 seconds
	Fuse protection rating	24-60V 6A, 120-240V 3A (slow-blow)

Undervoltage Release

In the event of loss or low level control circuit voltage, an undervoltage release may be used to automatically open the circuit breaker. To prevent nuisance breaker openings from temporary voltage dips, a separate adjustable time-delay undervoltage release is also available.



Under-voltage release UVR	Operating values	85 - 110% breaker can be closed, 35 - 70% breaker will open
	120 - 240VAC Coil voltage tolerance 24 - 250VDC	85 - 110% of nominal
	Coil voltage tolerance	85 - 126% of nominal
	Supply voltage	120, 240VAC or 24, 48, 125, 250VDC
	Power consumption	200VA inrush/ 5VA continuous (same in Watts for DC)
	Opening time of breaker	200 ms
	UVR w/o time delay (dual setting)	80 ms or 200ms
	UVR with time delay (adjustable delay)	0.2 to 3.2 sec.

^① See page 6-106 for field install part numbers.

WL Circuit Breaker

Factory Installed Options^①

The following items are available for WL cradles. Items are described to highlight the functional characteristics of these factory installed cradle options.

Secondary disconnects

Secondary disconnects are used to interconnect external breaker control and signaling circuitry to the WL breakers factory wired circuitry. Three types of external connection terminals are available. 1. Screw connection, 2. Tension spring connection and, 3. Ring lug connection. **Tension spring connection terminals are standard for fixed mounted breakers.**

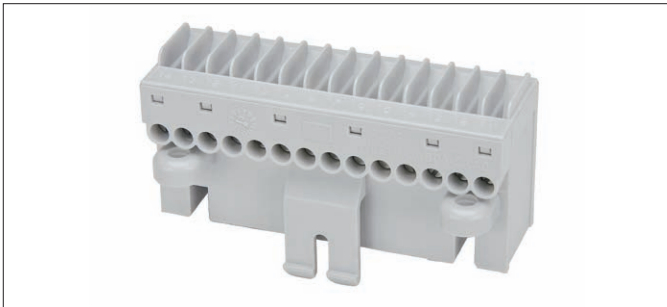

Secondary disconnects	Wire connection type	Number of wires and sizes
	Screw compression	1 x 14AWG or 2 x 16AWG
	Tension spring compression	2 x 14AWG
	Ring lug terminal	2 x 14AWG or 2 x 16AWG

Isolation Shutters

When removing a draw-out breaker from its connected position the primary contacts become exposed and more accessible to personnel in the breaker compartment. Isolation shutters reduce that accessibility to the primary terminals by automatically closing the access ports to the primary terminals whenever the breaker is disconnected or withdrawn. After removal of the breaker from its compartment, the shutters may be padlocked to inhibit manual shutter opening while breaker is not in the compartment.



Characteristics

PROFIBUS or MODBUS Communication

PROFIBUS or MODBUS communication requires a COM15 or COM16 converter to transmit WL breaker data to external PCs or PLC monitoring systems. External communication connection to either module is through a DB-9F connector.

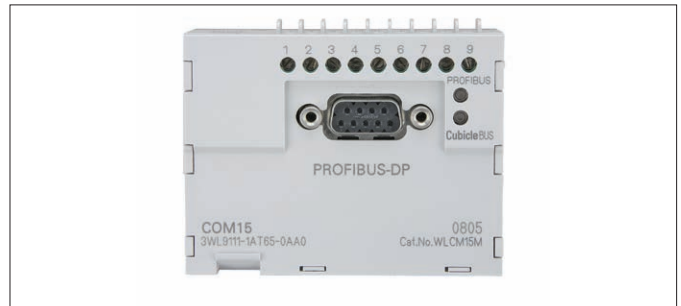

Operating voltage	24VDC
Peak inrush current	280mA
Max. continuous current	125mA
Ambient temperature	-25 to 70°C

Dual Key Breaker Locking

For draw-out breakers, a cradle-mounted breaker lockout device can be installed with either one or two independent key cylinders. The key is removable only when the breaker is locked open. Cradle-mounted key locks are commonly utilized for interlocking in open transition schemes, where paralleling certain sources is not desirable. Siemens offers the choice of unique, uncoordinated, Kirk and Superior key lock types. If a custom, coordinated key/cylinder is required, order the lock provision-only. The lock cylinder and matched key must then be ordered separately from the respective lock manufacturer.

The compatible Kirk cylinder lock part number is C-900-301. The compatible Superior cylinder lock part number is C-900.

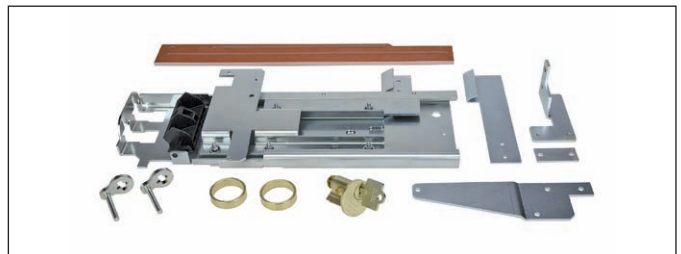

^① See page 6-106 for field install part numbers.

WL Circuit Breaker

Cradle Factory Installed Options^①

Characteristics

Arc Chute Cover

The arc chute cover is available for isolating enclosure material or parts located above the circuit breaker where heat and exhaust gases may exit from the breakers arc chutes. Arc chute covers are not available for fixed mounted breakers and limited to select draw-out breaker types.



TOC (Truck Operated Contacts)

For draw-out breaker applications a TOC device is available to provide remote indication of the circuit breakers primary and secondary contact connections (racking positions). When the breaker is racked into a connected, test or disconnected position, it activates TOC switches for external user circuits.

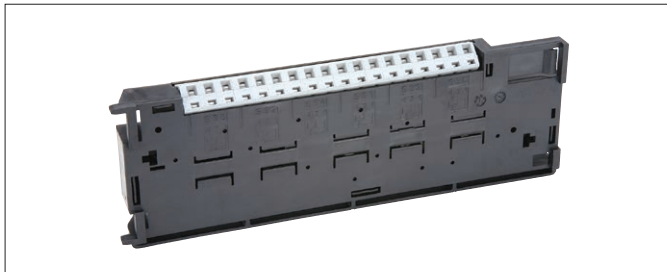

MOC (Mechanism Operated Contacts)

Mechanism Operated Contacts (MOC) are a cradle mounted accessory which indicate the state of the breaker's internal contacts (open or closed). MOCs are typically utilized when additional auxiliary contacts are necessary – above and beyond the number configurable in the circuit breaker – although they may also be used in lieu of the internal auxiliary switches. Each MOC assembly includes 4 'a' and 4 'b' contacts. Two different MOC assemblies are available. One version operates when the circuit breaker is in both the "TEST" and "CONNECTED" positions, and the other version operates only when the circuit breaker is in the "CONNECTED" position.

Note per ANSI C37.100:

'a' contact: a contact that is open when the main device is in the standard reference position and that is closed when the device is in the opposite position.
'b' contact: a contact that is closed when the main device is in the standard reference position and that is open when the device is in the opposite position.



MOC Contact Configurations	4NO and 4NC	
AC Operation	Voltage	240VAC 50/60Hz
	Continuous current	10A
	Making current	30A
	Breaking current	3A
DC Operation	Voltage	24, 125, 250VDC
	Making current	1.1A @ 125VDC, 0.55A @ 250VDC
	Breaking current	1.1A @ 125V DC, 0.55A @250VDC

TOC Switch	Breaker disconnected = Primary and secondary contacts are disconnected	Breaker in test = Primary contacts disconnected and secondary contacts are connected	Breaker connected = Primary and secondary contacts are connected
Option 1	1 form C contacts	1 form C contacts	1 form C contacts
Option 2	1 form C contacts	2 form C contacts	3 form C contacts
Option 3	0 form C contacts	0 form C contacts	6 form C contacts
	TOC Contact Ratings	AC Voltage	120, 240VAC
		AC Continuous Current	10A
		AC Making/Breaking Current	6A @120V, 3A @240VAC
		DC Voltage	24, 48, 125, 250VDC
		DC Continuous Current	6A, 1A, 1A
		DC Making/Breaking Current	6A, 0.22A, 0.11A

① See page 6-106 for field install part numbers.

WL Circuit Breaker

Accessories

Selection

Communication Power Supplies

For WL devices that require a 24VDC input we offer the Siemens SITOP power supply. The SITOP power supply is a class 2 rated devices suitable for supporting loads of 2.5 or 3.8 amps. DIN rail mounting provision and compression wire connections included. For loads of 2.5A maximum order part number **WLSITOP25** or **WLSITOP1** for 3.8A maximum loads.



Handheld Test Device

To test the WL breakers ETU trip functions we offer a handheld tester that checks:

- Sensor continuity
- Long-time function
- Short-time function
- Instantaneous function
- Neutral and ground fault function

During a test, the device will electrically trip the circuit breaker performing a full function test of the ETU and the trip actuator. Cables for 120VAC power supply and ETU connection is included with the tester. Order part number WLTS



Breaker Data Adapter PLUS

The BDAP can be used to read or modify the breaker ETU and Cubiclebus parameters using a laptop, pocket PC or remote desktop PC. Circuit breakers can be parameterized individually using one BDA with similar or different parameters. No software is required as the embedded software interface is through a PC browser. Connectivity to a PC or network can be serial (RS232) or Ethernet (TCP/IP) address. If the breaker ETU is energized with 24VDC control power the BDA can be powered through the interconnecting ribbon cable. Order part number **WLBADP**.



Mechanical Breaker Interlocks

Mechanical interlock options are available for fixed or draw-out breakers. Interlocking is managed through cable connections between two or three breakers less than 6 meters apart. Lock kit includes 2.0 meter interlocking cable and mechanism for mounting to a single breaker.

For fixed breaker frame size 1, Cat. No. **WLNTLKF1**

For fixed breaker frame size 2 or 3, Cat. No. **WLNTLKF23**

For draw-out breaker frame size 1, 2, or 3, Cat. No. **WLNTLK**



Alternate Cable Lengths

Length	Catalogue Number
3.0 meter	WLNTLWRE3
4.5 meter	WLNTLWRE4
6.0 meter	WLNTLWRE5

WL Circuit Breaker

Accessories

Selection

Metering Current Transformer 3-phase Window

(cradle mounting only)

For draw-out breaker applications, a three phase metering CT is available. Termination screws are integral to the mold for point-to-point wiring without the use of terminal blocks or wire couplers. Metering ratios range from 800:5 to 5000:5. CTs include mounting hardware.



For Frame Size 1 and 2

Rating	Catalogue Number
800:5	WLG8005MCT2
1200:5	WLG12005MCT2
1600:5	WLG16005MCT2
2000:5	WLG20005MCT2
2500:5	WLG25005MCT2
3200:5	WLG32005MCT2

For Frame Size 3

Rating	Catalogue Number
3200:5	WLG32005MCT3
4000:5	WLG40005MCT3
5000:5	WLG50005MCT3

4W Modified Differential Ground Fault (MDGF)

For MDGF draw-out breaker applications, a three phase iron-core CT is available. The MDGF CTs are physically the same as the above metering CTs but the current ratio is 1200:1.

For frame size 2, breakers catalogue number:
1200:1 rating **WLGMDGFCT2** Phase CT

For frame size 3, breakers catalogue number:
1200:1 rating **WLGMDGFCT3** Phase CT

For frame size 2 and 3, neutral CT catalogue number:
1200:1 rating **WLGNMDGCT23** Neutral CT

A typical application for modified differential ground fault is 'Main-Tie-Main' where all breakers require 3 Phase CTs and a neutral CT.

Metering current transformer – Single Phase

A single piece housing that is compact and designed to fit around phase or neutral bussing. Termination screws are integral to the mold for point-to-point wiring without the use of terminal blocks or wire couplers. Metering ratios range from 800:5 to 5000:5.



For Frame Size 1, 2 or 3

Rating	Catalogue Number
800:5	WLG800NMCT23
1200:5	WLG1200NMCT23
1600:5	WLG1600NMCT23
2000:5	WLG2000NMCT23
2500:5	WLG2500NMCT23
3000:5	WLG3000NMCT23
3200:5	WLG3200NMCT23
4000:5	WLG4000NMCT23
5000:5	WLG5000NMCT23

Neutral Current Sensor – 4-wire Residual Ground Fault

For 4-wire residual ground fault protection we offer neutral current sensors with or without bus bar coupling. The sensors are comparable to the sensors used within the breaker and connected to the ETU. This sensor must also be wired to the ETU through designated secondary disconnects on the breaker.

Without copper bus adapters:

- 3" max bus bar width catalogue number **WLNCT2**
- 3 - 5" bus bar width catalogue number **WLNCT3**

With copper bus adapters:

- 3" max bus bar width catalogue number **WLNCT2CB**
- 3 - 5" bus bar width catalogue number **WLNCT3CB**

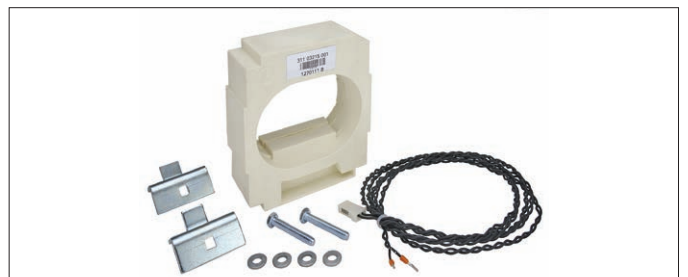

WL Circuit Breaker

Accessories

Selection

Breaker Door Cover

A transparent hinged door cover is available to provide IP55 protection. Provision for padlocking included. Fits frame size 2 and 3 breakers. Catalogue number: **WLPGC**



Door Sealing Frame

For openings around the door cutout of the breaker, this rubber door trim is available. For frame size 2 and 3 breakers only. Catalogue number: **WLDSF**



Breaker Lifting

The breaker lifting yolk is designed to transport the WL breaker when using a hoist or other lifting equipment. The device is expandable to conform to all three WL frame sizes and easily attaches to specified lift points on the breaker. Catalogue number: **WLLFT**

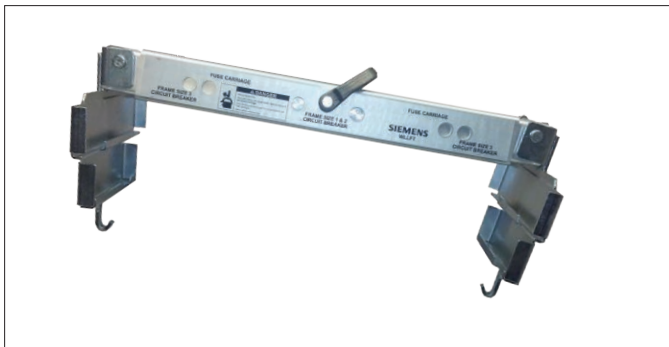

Remote Breaker Racking Device

Provides the ability to safely rack WL breakers into the Connect, Test and Disconnect positions from 30 feet away from the breaker, allowing the operator to be outside the arc flash boundary which provides additional personnel protection. Catalogue number: **WLRBRD**

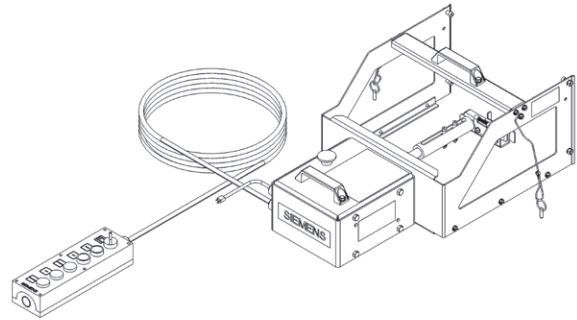

Door Bracket Kit, Remote Breaker Racking Device

In order to mount the remote breaker racking device on existing gear, this retrofit door bracket kit and the WLRBRDTEMPL must be ordered. Catalogue number: **WLRBRDKIT**.

Remote Breaker Racking Device Door Bracket Install Template
In order to mount the remote breaker racking device on existing gear, this mounting template and the WLRBRDKIT must be ordered. Catalogue number: **WLRBRDTEMPL**

Breaker Hoist

This device acts as a hoist for the WL breaker, allowing it to be carried using a forklift or similar device. Catalogue number: **WLHOIST**



WL Circuit Breaker

Accessories

Selection

CubicleBUS Modules

External CubicleBUS modules enable the WL Circuit Breaker a way to interface with external switchgear controls or building management systems. They can be used, for example, to activate analog displays or devices, transmit circuit breaker status and cause of trip, or read external device control signals. One module is suitable for zone-selective interlocking main and branch breakers.

Three different CubicleBUS modules can output data from the CubicleBUS system (two digital output modules and one analog output module). A digital input module can transmit data from the switchgear or system to a PROFIBUS/MODBUS master device like a power meters or logic controllers.

Digital Output Module with Rotary Switch – The digital output module can be used to output six events. These events can be warnings or trips and can be used for external annunciation or control. The load shedding and load restoring signals can enable a load to be switched ON or OFF automatically. Voltages of up to 250V AC/DC are possible. The relay contacts are isolated.

Relay Digital Output Module: Catalogue number **WLRLYCUB**



ZSI Module

To use the ZSI function with the WL Circuit Breaker, the external CubicleBUS ZSI module must be implemented. The zone selective interlocking (ZSI) module provides the complete range of selectivity with the short delay time of $t_{ZSI} = 50$ ms, irrespective of the number of levels and the location of the short-circuit in a distribution system. Its benefits become even more apparent, the higher the number of levels in large systems and the longer the resulting delay times. By shortening the time, the ZSI module significantly reduces stress and damage in the event of a short-circuit in the switchgear.

Zone Selective Interlocking Module: Catalogue number **WLZSIMD**



Analog Output Module

The analog output module can be used to output the most important measured values sent via the CubicleBUS to analog indicators (e.g. analog meters) in the switchgear cubicle door. Each analog output module has four channels for this purpose. The signals are available at two physical interfaces: a 4 ... 20mA and a 0 ... 10V interface.

Analog Output Module: Catalogue number **WLANLGCUB**



Digital Input Module

The digital input module enables up to six additional binary signals (24V DC) to be connected. Signals, such as breaker status, arc-flash current reduction, over-temperature conditions or control circuit status switchgear, can be transmitted directly to the power monitoring network.

A total of 6 inputs are available in the "BUS Input" Switch position. Six inputs are also available if the rotary switch is in the "Parameter Switch" position, although the first input causes the active parameter set to change. If the connected ETU does not have two parameter set capability (e.g. ETU745 or ETU748), this input can also be used without any restrictions.

Digital Input Module: Catalogue number: **WLDGNCUB**



Pre-assembled CubicleBUS Communication Cables

(RJ45-M connections)

Description	Catalogue Number
1 meter length	WLCBUSCABLE1
2 meter length	WLCBUSCABLE2
4 meter length	WLCBUSCABLE4
9 meter length	WLCBUSCABLE9

WL Circuit Breaker

Accessories

Selection

Fixed-mounted Breaker Front Bus Connectors

Front connector bus kits are available for adapting WL breaker primary mounting stabs to a standard NEMA bussing and bolt-hole pattern. NEMA bolt connection is accessible from the front of the breaker for ease of installation or removal of breaker inside an enclosure. Kit includes the required bus and hardware for mounting one 3-pole set of adapters to a breaker.

Description	Catalogue Number
Frame size 1, 1200A frame, 85 kAIC at 480V	WLH1F12CONUL
Frame size 2, 1600A frame, 100kAIC at 480V	WLL2F16CONUL
Frame size 2, 2000A frame, 100kAIC at 480V	WLL2F20CONUL
Frame size 2, 2500A frame, 100kAIC at 480V	WLL2F25CONUL
Frame size 2, 3000A frame, 100kAIC at 480V	WLL2F30CONUL
Frame size 3, 4000 to 5000A frame, 100kAIC at 480V	WLL3F50CONUL

Mechanical lug connector kits are available for connecting 800 to 2000A WL front connector bus kits (sold separately) to power cables.

Description	Catalogue Number
Frame size 1, 1200A max, 65 kAIC at 480V	WLS2P12CONUL
Frame size 2, 1600 to 2000A max, 65kA 65 kAIC at 480V	WLS2P20CONUL

Fixed mounted breaker rear bus connector kits are available for adapting WL breaker primary mounting stabs to a standard NEMA bussing and bolt-hole pattern. Adapters also rotate the primary breaker connections by 90° for vertical bus arrangement. Bolted connections are accessible from the rear of the breaker. Kit includes the required bus and hardware for mounting one 3-pole set of adapters to a breaker.

Description	Catalogue Number
Frame size 1, 1200A frame, 85 kAIC at 480V	WLH1R12CONUL
Frame size 2, 1600A frame, 100 kAIC at 480V	WLL2R16CONUL
Frame size 2, 2000A frame, 100 kAIC at 480V	WLL2R20CONUL
Frame size 2, 3000A frame, 100 kAIC at 480V	WLL2R30CONUL
Frame size 2, 800A to 3000A frame, 150 kAIC at 480V Rated Breaker Only	WLC2R30CONUL
Frame size 3, 4000A to 5000A frame, 100 kAIC at 480V	WLC3R50CONUL



WL Circuit Breaker

WL Catalogue Numbering

Overview

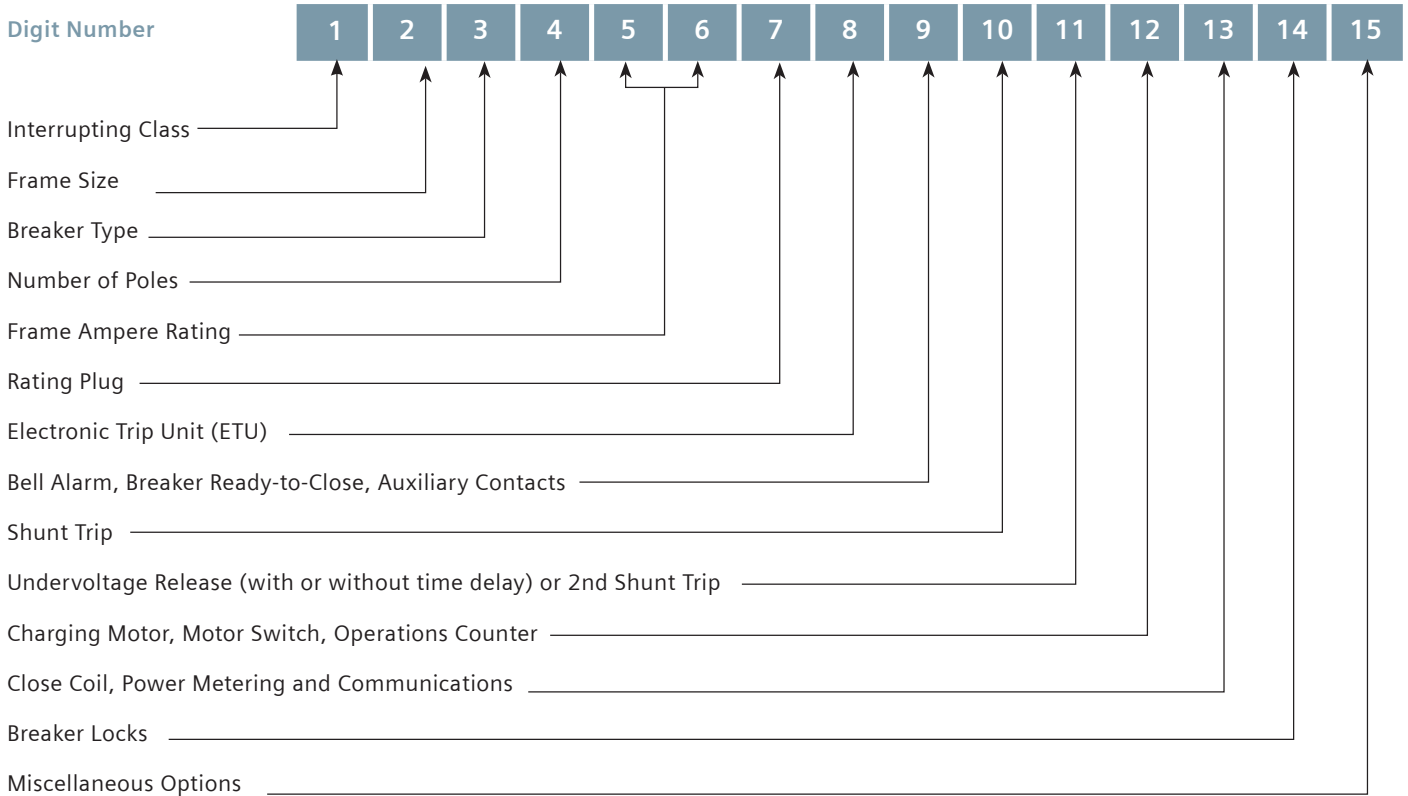

6

WL POWER
CIRCUIT BREAKERS

WL Insulated Case Circuit Breaker

Ratings for UL489 Listed Breakers

Selection

WL frame ratings – frame size 1		800A			1200A			1600A			2000A		
Rating Class		S	H	L	S	H	L	S	H	L	S	H	L
Interrupting current frame Ics (kAIR RMS) 50/60 Hz	240VAC	65	85	100	65	85	100	65	85	100	65	85	100
	480VAC	65	85	100	65	85	100	65	85	100	65	85	100
	600VAC	65	65	65	65	65	65	65	65	65	65	65	65
Short-time current Icw (kA RMS)		0.4 sec.		65	65	65	65	65	65	65	65	65	65
Extended instantaneous protection rating (kA RMS)	480VAC	65	85	100	65	85	100	65	85	100	65	85	100
	600VAC	65	65	65	65	65	65	65	65	65	65	65	65
Close and latch rating (kA RMS)		65	65	65	65	65	65	65	65	65	65	65	65
Applicable rating plug range		200 - 800A			200 - 1200A			200 - 1600A			200 - 2000A		
Minimum enclosure dimension (in.)		22Wx15Hx19.5D			22Wx15Hx19.5D			22Wx15Hx19.5D			22Wx15Hx19.5D		
Mechanical make-time (ms)		35			35			35			35		
Mechanical break-time (ms)		34			34			34			34		
Electric close make-time (ms)		50			50			50			50		
Electric trip/ UV break-time (ms)		40/73			40/73			40/73			40/73		
Electric trip and reclose interval (ms)		80			80			80			80		
Mechanical duty cycles (no maint.)		7500			7500			7500			7500		
Electrical duty cycles (no maint.)		7500			7500			7500			7500		
Draw-out breaker efficiency (Watts loss at In)		80			180			350			530		
Fixed-mount breaker efficiency (Watts loss at In)		60			120			160			270		
Ambient operating temperature (°C)		-25 to 40			-25 to 40			-25 to 40			-25 to 40		
Weights (Fixed Breaker/DO Breaker/Cradle) lbs.		86/137/108			86/137/108			86/137/108			86/137/108		

WL frame ratings – frame size 2		800A			1200A			1600A			2000A			2500A		3000A		
Rating Class		S	L	C	S	L	C	S	L	C	S	L	C	L	C	L	C	
Interrupting current frame Ics (kAIR RMS) 50/60 Hz	240VAC	65	100	150	65	100	150	65	100	150	65	100	150	100	150	100	150	
	480VAC	65	100	150	65	100	150	65	100	150	65	100	150	100	150	100	150	
	600VAC	65	85	100	65	85	100	65	85	100	65	85	100	85	100	85	100	
Short-time current Icw (kA RMS)		0.4 sec.		65	85	100	65	85	100	65	85	100	85	100	85	100	85	100
Extended instantaneous protection rating (kA RMS)	480VAC	65	100	150	65	100	150	65	100	150	65	100	150	100	150	100	150	
	600VAC	65	85	100	65	85	100	65	85	100	65	85	100	85	100	85	100	
Close and latch rating (kA RMS)		65	85	100	65	85	100	65	85	100	65	85	100	85	100	85	100	
Applicable rating plug range		200 - 800A			200 - 1200A			200 - 1600A			200 - 2000A			200 - 2500A		200 - 3000A		
Minimum enclosure dimension (in.)		22Wx22.5Hx19.5D			22Wx22.5Hx19.5D			22Wx22.5Hx19.5D			22Wx22.5Hx19.5D			22Wx22.5Hx19.5D		22Wx15Hx19.5D		
Mechanical make-time (ms)		35			35			35			35			35		35		
Mechanical break-time (ms)		34			34			34			34			34		34		
Electric close make-time (ms)		50			50			50			50			50		50		
Electric trip/ UV break-time (ms)		40/73			40/73			40/73			40/73			40/73		40/73		
Electric trip and reclose interval (ms)		80			80			80			80			80		80		
Mechanical duty cycles (no maint.)		10,000 (5000 for Class C)			10,000 (5000 for Class C)			10,000 (5000 for Class C)			10,000 (5000 for Class C)			10,000 (5000 for Class C)		10,000 (5000 for Class C)		
Electrical duty cycles (no maint.)		7500 (5000 for Class C)			7500 (5000 for Class C)			7500 (5000 for Class C)			4000			4000		4000		
Draw-out breaker efficiency (Watts loss at In)		85			150			320			500			680		1000		
Fixed-mount breaker efficiency (Watts loss at In)		40			80			120			230			320		480		
Ambient operating temperature (°C)		-25 to 40			-25 to 40			-25 to 40			-25 to 40			-25 to 40		-25 to 40		
Weights (Fixed Breaker/DO Breaker/Cradle) lbs.		124/159/112 148/220/163 (Class C)			124/159/112 148/220/163 (Class C)			124/159/112 148/220/163 (Class C)			130/177/128 148/220/163 (Class C)			130/177/128 148/220/163 (Class C)		130/177/128 148/220/163 (Class C)		

6
WL POWER
CIRCUIT BREAKERS

NOTE: Frame Size 1 H-Class only for switches

WL Insulated Case Circuit Breaker

Ratings for UL489 Listed Breakers

Characteristics

WL frame ratings – Frame size 3		4000A		5000A	
Rating Class		L	C	L	C
Interrupting current frame Ics (kAIR RMS) 50/60 Hz	240VAC	100	150	100	150
	480VAC	100	150	100	150
	600VAC	85	100	85	100
Short-time current Icw (kA RMS)	0.4 sec.	85	100	85	100
Extended instantaneous protection rating (kA RMS)	480VAC	100	150	100	150
	600VAC	85	100	85	100
Close and latch rating (kA RMS)		85	100	85	100
Applicable rating plug range		800 - 4000A		800 - 5000A	
Minimum enclosure dimension (in.)		32Wx22.5Hx19.5D		32Wx22.5Hx19.5D	
Mechanical make-time (ms)		35		35	
Mechanical break-time (ms)		34		34	
Electric close make-time (ms)		50		50	
Electric trip/ UV break-time (ms)		40/73		40/73	
Electric trip and reclose interval (ms)		80		80	
Mechanical duty cycles (no maint.)		5000		5000	
Electrical duty cycles (no maint.)		2000		2000	
Draw-out breaker efficiency (Watts loss at In)		1100		1100	
Fixed-mount breaker efficiency (Watts loss at In)		580		580	
Ambient operating temperature (°C)		-25 to 40		-25 to 40	
Weights (Fixed Breaker/DO Breaker/Cradle) lbs.		181/278/306		181/278/306	
		200/278/306		200/278/306	
		(Class C)		(Class C)	

Ratings for UL489 Listed non-automatic switches

WL frame ratings		Frame size 1 800-1200 A	Frame size 2 800 - 3000A	Frame size 3 4000/5000A
Rating Class		H	L	L
Breaking capacity with external relay (kA RMS) 50/60 Hz, instantaneous trip	240VAC	85	100	100
	480VAC	85	100	100
	600VAC	65	85	85
Short-time current Icw (kA RMS)	0.4 sec.	65	85	85

WL Insulated Case Circuit Breaker

UL 489 Listed Catalogue Number

Selection

Rating Plug	For use with frame size			Breaker catalog number															
	1	2	3	1	2	3	4	5	6	7	8	9	10	11	12	13	14	15	
Maximum continuous current rating																			
200	X	X																	A
225	X	X																	B
250	X	X																	C
300	X	X																	D
315	X	X																	E
350	X	X																	F
400	X	X																	G
450	X	X																	H
500	X	X																	J
600	X	X																	K
630	X	X																	L
700	X	X																	M
800	X	X	X																N
1000	X	X	X																P
1200	X	X	X																Q
1250	X	X	X																R
1600	X	X	X																T
2000	X	X	X																U
2500		X	X																V
3000		X	X																W
4000			X																Z
5000			X																1

Electronic trip unit (ETU)¹⁾

Trip unit models	Protective function			LCD display Alpha num.	Ground fault		
	L	S	I		Alarm	Trip	
ETU745	X	(X)	(X)				C
ETU745	X	(X)	(X)	X			D
ETU745	X	(X)	(X)		X		E
ETU745	X	(X)	(X)	X	X		F
ETU745	X	(X)	(X)		X	X	G
ETU745	X	(X)	(X)	X	X	X	H
ETU748	X	X					J
ETU748	X	X		X			K
ETU748	X	X			X		L
ETU748	X	X		X	X		N
ETU748	X	X			X	X	P
ETU748	X	X		X	X	X	Q
ETU776	X	(X)	(X)				V
ETU776	X	(X)	(X)		X		W
ETU776	X	(X)	(X)		X	X	Y

(X) Indicates function can be disabled by user
 ① Neutral protection "N" is available as standard.

WL Insulated Case Circuit Breaker

UL 489 Listed Catalogue Number

Selection

Bell alarm, breaker ready-to-close, auxiliary contacts

					Breaker catalog number															
					1	2	3	4	5	6	7	8	9	10	11	12	13	14	15	
Bell alarm		Form C contacts	Breaker ready-to-close 1b contact	Breaker open/close auxiliary switches																
Remote reset coil voltage				2a + 2b	4a + 4b															
AC	DC					None														
																				X
		X																		A
			X																	B
				X																C
					X															D
		X	X																	E
		X			X															F
		X				X														G
			X		X															H
			X		X															I
		X	X		X															J
		X	X			X														K
	24	X																		L
	48	X																		M
120	125	X																		N
240	250	X																		O
	24	X	X																	P
	48	X	X																	Q
120	125	X	X																	R
240	250	X	X																	S
	24	X			X															T
	48	X			X															U
120	125	X			X															V
240	250	X			X															W
	24	X										X								Y
	48	X										X								Z
120	125	X										X								1
240	250	X										X								2
	24	X	X		X															3
	48	X	X		X															4
120	125	X	X		X															5
240	250	X	X		X															6
	24	X	X			X														7
	48	X	X			X														8
120	125	X	X									X								9
240	250	X	X									X								0

Shunt trip

Operation voltage		Status contact	Continuous duty coil (electrical interlock)																		
AC	DC			None																	
																					X
	24																				A
	48																				B
120	125																				C
240	250																				D
	24	X																			E
	48	X																			F
120	125	X																			G
240	250	X																			H
	24				X																J
	48				X																K
120	125				X																L
240	250				X																M
	24	X			X																N
	48	X			X																P
120	125	X			X																R
240	250	X			X																S

WL Insulated Case Circuit Breaker

UL 489 Listed Catalogue Number

Selection

Undervoltage Release (with or without time delay) or 2nd Shunt Trip					Breaker catalog number														
					1	2	3	4	5	6	7	8	9	10	11	12	13	14	15
Operation voltage		UVR without delay	UVR with delay	UVR status ¹ contact (1NO)	2nd shunt trip											X			
AC	DC																		
						None													
	24	X															A		
	48	X															B		
120	125	X															C		
240	250	X															D		
	48		X														E		
120	125		X														F		
240	250		X														G		
	24				X												H		
	48				X												J		
120	125				X												K		
240	250				X												L		
	24	X		X													M		
	48	X		X													N		
120	125	X		X													P		
240	250	X		X													Q		
	48		X	X													R		
120	250		X	X													S		
240	250		X	X													T		

Charging motor, motor switch, operations counter

Charging motor operation voltage		Motor cut-off switch	Operations counter											X			
AC	DC																
				None													
	24																A
	48																B
120	125																C
240	250																D
	24	X															E
	48	X															F
120	125	X															G
240	250	X															H
	24			X													J
	48			X													K
120	125			X													L
240	250			X													M
	24	X	X														N
	48	X	X														P
120	125	X	X														Q
240	250	X	X														R

¹ Status contact is only available when Communications is not installed on breaker. Signal is sent via communications in lieu of status contact.

WL Insulated Case Circuit Breaker

UL 489 Listed Catalogue Number

Selection

Close coil, power metering and communications				Breaker catalog number															
				1	2	3	4	5	6	7	8	9	10	11	12	13	14	15	
Close coil operation voltage		Power metering capable	MODBUS ²	PROFIBUS ²	None												X		
AC	DC																		
	24																A		
	48																B		
120	125																C		
240	250																D		
			X														G		
				X													H		
	24		X														N		
	24			X													P		
	48		X														S		
	48			X													T		
120	125		X														W		
120	125			X													Y		
240	250		X														2		
240	250			X													3		
	24	X	X														Q		
	48	X	X														U		
120	125	X	X														Z		
240	250	X	X														4		
	24	X						X									R		
	48	X						X									V		
120	125	X						X									1		
240	250	X						X									5		
		X	X														L		
		X		X													M		
		X															F		
	24	X															6		
	48	X															7		
120	125	X															8		
240	250	X															9		

Breaker locks

Key lock breaker OPEN position (lock type – KIRK) ¹	Key lock breaker OPEN position (lock type – SUPERIOR) ¹	Padlock provisions for OPEN and CLOSE push buttons ²	Padlock provisions for charging handle ²	None												X		
X																	A	
		X															C	
			X														E	
	X																F	
X		X															G	
	X	X															J	
X			X														S	
	X			X													U	
		X	X														V	
X		X	X														W	
	X	X	X														Z	

Miscellaneous options

Key lock breaker OPEN position (provision only) ²	Manual trip reset ETU (Automatic trip reset is standard)	None												N			
X																	B
	X																C
X	X																D

¹ Custom key locks are not available and must be supplied by others. Order key lock provision if custom if keyed alike locks are required.

² Locks provided by others.

WL Insulated Case Switch

UL 489 Listed Non-automatic Catalogue Number

Selection

Breaking capacity, frame size, switch type and frame rating

Class	Breaking capacity (kA)		Frame Max ampere rating (A)	Frame size		Switch type		Switch catalog number														
	240VAC 480VAC	600VAC		2	3	Fixed mounted	drawout	1	2	3	4	5	6	7	8	9	10	11	12	13	14	15
								↑	↑	↑	↑	↑	↑	↑	↑	↑	↑	↑	↑	↑	↑	↑
L	100	85	1600	X		X		L	2	Y	3	1	6	S	S							
L	100	85	1600	X			X	L	2	Z	3	1	6	S	S							
L	100	85	2000	X		X		L	2	Y	3	2	0	S	S							
L	100	85	2000	X			X	L	2	Z	3	2	0	S	S							
L	100	85	2500	X		X		L	2	Y	3	2	5	S	S							
L	100	85	2500	X			X	L	2	Z	3	2	5	S	S							
L	100	85	3000	X		X		L	2	Y	3	3	0	S	S							
L	100	85	3000	X			X	L	2	Z	3	3	0	S	S							
L	100	85	4000		X	X		L	3	Y	3	4	0	S	S							
L	100	85	4000		X		X	L	3	Z	3	4	0	S	S							
L	100	85	5000		X	X		L	3	Y	3	5	0	S	S							
L	100	85	5000		X		X	L	3	Z	3	5	0	S	S							

Ready-to-close and auxiliary contacts

Ready-to-close 1b contact	Breaker open/close auxiliary switches			
	2a + 2b	4a + 4b		
			None	X
X				B
	X			C
		X		D
X	X			H
X		X		I

WL Insulated Case Switch

UL 489 Listed Non-automatic Catalogue Number

Selection

Shunt trip

Operation voltage		Status contact ¹	Shunt trip	Continuous duty rated (electrical interlock)	Switch catalog number														
AC	DC				1	2	3	4	5	6	7	8	9	10	11	12	13	14	15
				None								X							
	24		X									A							
	48		X									B							
120	125		X									C							
240	250		X									D							
	24	X	X									E							
	48	X	X									F							
120	125	X	X									G							
240	250	X	X									H							
	24			X								J							
	48			X								K							
120	125			X								L							
240	250			X								M							
	24	X		X								N							
	48	X		X								P							
120	125	X		X								R							
240	250	X		X								S							

Undervoltage release (with or without time delay) or 2nd shunt trip

Operation voltage		UVR without delay	UVR with delay	UVR status ¹ contact (1NO)	2nd shunt trip	Switch catalog number														
AC	DC					1	2	3	4	5	6	7	8	9	10	11	12	13	14	15
					None							X								
	24	X										A								
	48	X										B								
120	125	X										C								
240	250	X										D								
	48		X									E								
120	125		X									F								
240	250		X									G								
	24				X							H								
	48				X							J								
120	125				X							K								
240	250				X							L								
	24	X		X								M								
	48	X		X								N								
120	125	X		X								P								
240	250	X		X								Q								
	48		X	X								R								
120	250		X	X								S								
240	250		X	X								T								

¹ Status contact is only available when communication is not installed. Signal is sent via communications in lieu of status contact.

WL Insulated Case Switch

UL 489 Listed Non-automatic Catalogue Number

Selection

Charging motor, motor switch and operation counter

Switch catalog number

Charging motor operation voltage		Motor cut-off switch	Operations counter	Switch catalog number														
AC	DC			1	2	3	4	5	6	7	8	9	10	11	12	13	14	15
															X			
	24														A			
	48														B			
120	125														C			
240	250														D			
	24	X													E			
	48	X													F			
120	125	X													G			
240	250	X													H			
	24														J			
	48														X			
120	125														X			
240	250														X			
	24	X													X			
	48	X													X			
120	125	X													X			
240	250	X													X			

Close coil, communications

Close coil operation voltage		Modbus ¹	PROFIBUS ¹	Switch catalog number														
AC	DC			1	2	3	4	5	6	7	8	9	10	11	12	13	14	15
																	X	
	24	X															G	
	24	X															A	
	48																N	
	48	X															B	
120	125																S	
120	125	X															C	
240	250																W	
240	250	X															D	
	24															X	H	
	48															X	P	
	48															X	T	
120	125															X	Y	
240	250															X	3	

¹ Requires 24VDC power supply. Power metering not available on non-automatic switches and BSS is included.

WL Insulated Case Switch

UL 489 Listed Non-automatic Catalogue Number

Selection

Switch locks				Switch catalog number														
				1	2	3	4	5	6	7	8	9	10	11	12	13	14	15
Key lock breaker OPEN position (lock type – KIRK) ¹	Key lock breaker OPEN position (lock type – SUPERIOR) ¹	Padlock provisions for OPEN and CLOSE push buttons ²	Padlock provisions for charging handle	None													X	
X		X															A	
			X														C	
	X																E	
X		X															F	
	X	X															G	
X																	J	
	X		X														S	
			X														U	
X		X	X														V	
	X	X	X														W	
		X	X														Z	
Miscellaneous options																		
Key lock breaker OPEN position (provision only) ²				None													N	
X																	B	

¹ Custom key locks are not available and must be supplied by others. Order Key Lock Provisions if custom keys or keyed alike locks are required.

² Padlock provided by others.

WL Insulated Case Circuit Breaker

UL 489 Listed Accessories

Selection

External breaker accessories

Description	Catalog number
Front mount connectors for fixed breakers	
FS1, 85kAIC at 480V max. 800A, 1200A	WLHF12CONUL
FS2, 100kAIC at 480V max. 1600A	WLL2F16CONUL
FS2, 100kAIC at 480V max. 2000A	WLL2F20CONUL
FS2, 100kAIC at 480V max. 3000A	WLL2F30CONUL
FS3, 100kAIC at 480V max. 4000A, 5000A	WLL3F50CONUL
Mechanical lug	
FS1, 65kAIC at 480V max 800A, 1200A	WLS2P12CONUL
FS2, 65kAIC at 480V max 1600A, 2000A	WLS2P20CONUL
Rear vertical connectors	
FS1, 100kAIC at 480V max 800A, 1200A, 1600A, 2000A	WLH1R12CONUL
FS2, 100kAIC at 480V max 800A, 1200A, 1600A	WLL2R16CONUL
FS2, 100kAIC at 480V max 2000A	WLL2R20CONUL
FS2, 1100kAIC at 480V max 2500A, 3000A	WLL2R30CONUL
FS2, 150kAIC at 480V max 800A, 1200A, 1600A, 2000A, 2500A, 3000A	WLC2R30CONUL
FS3, 150kAIC at 480V max 4000A, 5000A	WLC3R50CONUL
Single phase CTs for metering, 5A secondary	
Rating: 800:5	WLG800NMCT23
Rating: 1200:5	WLG1200NMCT23
Rating: 1600:5	WLG1600NMCT23
Rating: 2000:5	WLG2000NMCT23
Rating: 2500:5	WLG2500NMCT23
Rating: 3000:5	WLG3000NMCT23
Rating: 4000:5	WLG4000NMCT23
Rating: 5000:5	WLG5000NMCT23
Modified differential ground fault (MDGF) CTs	
Modified differential GF (FS2 1200:1) Phase CT	WLGMDGFCT2
Modified differential GF (FS3 1200:1) Phase CT	WLGMDGFCT3
Modified differential GF (FS2 and FS3 1200:1) Neutral CT	WLGNMDFCT23
4-wire residual ground fault sensor	
Without copper bus adapters (pass-thru mount) - for 3" max bus bar	WLNCT2
Without copper bus adapters (pass-thru mount) - for 3 - 5" max bus bar	WLNCT3
With copper bus adapters for bus bar connection - for 3" max bus bar	WLNCT2CB
With copper bus adapters for bus bar connection - for 3 - 5" max bus bar	WLCNMDGCT23
Mechanical interlocks	
Fixed mounted breaker (FS1)	WLNTLKF1
Fixed mounted breaker (FS2 and FS3)	WLNTLKF23
Miscellaneous external accessories	
Crimp lugs for 10# AWG secondary wiring (package of 70)	WL10RL
Auxiliary contact on drawout breaker (knife block)	WLCNMD
24V DC trip unit and communications power supply, 2.5A SITOP power, Class 2	WLSITOP25
24V DC trip unit and communications power supply 3.8A SITOP power, Class 2	WLSITOP1
Optional metric inserts and bolts for breaker mains (4 each) M8x25 for FS1 and FS2	WLMETRC
Optional metric inserts and bolts for breaker mains (4 each) M10x25 for FS3	WLMETRC3
Secondary disconnect coding kit for UL 489 fixed mounted breaker	WLCODEKITUL
Pull apart terminal block with 1 meter leads for UL 489 fix mounted breakers	WLTERMBLKUL

WL Insulated Case Breaker Cradles

UL 489 Listed Catalogue Number

Selection

Interrupting rating, frame size, and frame rating

Cradle catalog number

Class	Interrupt rating (kA)		Frame Max ampere rating (A)	Frame size			Cradle catalog number																
	240VAC 480VAC	600VAC		1	2	3	G	2	3	4	5	6	7	8	9	10	11	12	13	14	15		
S	65	65	800	X			S	1	3	0	8												
S	65	65	800		X		S	2	3	0	8												
S	65	65	1200	X			S	1	3	1	2												
S	65	65	1200		X		S	2	3	1	2												
S	65	65	1600	X			S	1	3	1	6												
S	65	65	1600		X		S	2	3	1	6												
S	65	65	2000	X			S	1	3	2	0												
S	65	65	2000		X		S	2	3	2	0												
L	100	65	800	X			L	1	3	0	8												
L	100	85	800		X		L	2	3	0	8												
L	100	65	1200	X			L	1	3	1	2												
L	100	85	1200		X		L	2	3	1	2												
L	100	65	1600	X			L	1	3	1	6												
L	100	85	1600		X		L	2	3	1	6												
L	100	65	2000	X			L	1	3	2	0												
L	100	85	2000		X		L	2	3	2	0												
L	100	85	2500		X		L	2	3	2	5												
L	100	85	3000		X		L	2	3	3	0												
L	100	85	4000			X	L	3	3	4	0												
L	100	85	5000			X	L	3	3	5	0												
C	150	100	800		X		C	2	3	0	8												
C	150	100	1200		X		C	2	3	1	2												
C	150	100	1600		X		C	2	3	1	6												
C	150	100	2000		X		C	2	3	2	0												
C	150	100	2500		X		C	2	3	2	5												
C	150	100	3000		X		C	2	3	3	0												
C	150	100	4000			X	C	3	3	4	0												
C	150	100	5000			X	C	3	3	5	0												

Type of secondary terminal connection ¹	
For breakers:	
Screw clamp terminals	A
Spring clamp terminals	B
Ring terminals	C
Screw clamp terminals (low profile, non-partable design)	L
For switches (non-automatic):	
Screw clamp terminals	G
Spring clamp terminals	H
Ring terminals	J
Screw clamp terminals (low profile non-partable design)	N
Truck Operated Contacts (TOC)	
Breaker position switches in the following configurations:	
None	X
(1) Connected, (1) Test, (1) Disconnected - all Form C	1
(3) Connected, (2) Test, (1) Disconnected - all Form C	3
(6) Connected - all Form C	6
Cradle mounted key locks – FS2 and FS3 only	
None	X
Lock breaker in OPEN position (Kirk lock)	A
Lock breaker in OPEN position (Superior lock)	B
Double-key lock breaker in OPEN position (Kirk lock)	C
Double-key lock breaker in OPEN position (Superior lock)	D
Provision only - Lock breaker in OPEN position	E
Provision only - Double-key lock breaker in OPEN position	F
Primary conductor isolation shutter	
None	X
Isolation Shutter	F

¹ Terminal blocks (X5, X6, X8, X9) are installed as standard.

WL Insulated Case Breaker Cradle

UL 489 Listed Catalogue Number

Selection

				Cradle catalog number														
				G	2	3	4	5	6	7	8	9	10	11	12	13	14	15
Arc chute covers																		
None														X				
Arc chute covers (FS1 only)														C				
Arc chute covers (FS2 only)														D				
Arc chute covers (FS3 only – except Class C)														B				
Door locks and mechanical interlocks																		
1. Mechanical interlock with 2.0 meter Bowden cable																		
2. Locks cubicle door, when breaker is in connect position																		
3. Locks cubicle door, when breaker is in connect position																		
4. Locks against racking breaker if the cubicle door is open																		
1	2	3	4															
														None				
														X				
X														M				
	X													A				
		X												B				
			X											C				
X	X													D				
X	X		X											E				
X		X												F				
X			X											G				
	X		X											H				
Mechanism Operated Contacts (MOC)																		
Breaker open/close auxiliary switches (4a & 4b) in the following positions:																		
None																		X
Test and Connect position (FS1 and FS2 only)																		M
Connect position (FS1 and FS2 only)																		N
Test and Connect position (FS3 only)																		P
Connect position (FS3 only)																		Q
Connector and heater options																		
Standard rear connectors																		X
Standard rear connectors and a cradle heater (FS2 and FS3)																		H
Rotatable rear connector (FS1 and FS2 2000A and below, S Class)																		J
Rotatable rear connectors and a cradle heater (FS2 2000A and below, S Class)																		K
Future use																		
Placeholder (required)																		N

WL Insulated Case Breaker Cradles

UL 489 Listed Accessories

Selection

Cradle accessories		Catalog number
3-phase metering CTs, cradle mounted (3 windows per CT)		
FS1 and FS2	Rating – 800:5	WLG8005MCT2
	Rating – 1200:5	WLG12005MCT2
	Rating – 1600:5	WLG16005MCT2
FS2	Rating – 2500:5	WLG25005MCT2
	Rating – 3000:5	WLG30005MCT2
FS3	Rating – 4000:5	WLG40005MCT3
	Rating – 5000:5	WLG50005MCT3

WL Power Circuit Breaker

Ratings for UL 1066 Listed (ANSI C37) Breakers

Selection

WL frame ratings – Frame size 2		800A					1600A				
Rating Class		N	S	H	L	F	N	S	H	L	F
Interrupting current frame <i>I</i> _{cs} (kAIC RMS) 50/60 Hz	254VAC	50	65	85	100	200	50	65	85	100	200
	508VAC	50	65	85	100	200	50	65	85	100	200
	600VAC	—	—	—	—	200	—	—	—	—	200
	635VAC	50	65	65	85	—	50	65	65	85	—
Short-time current <i>I</i> _{cw} (kA RMS)	1 sec.	50	65	65	85	—	50	65	65	85	—
Close and latch rating (kA RMS)		50	65	65	85	—	50	65	65	85	—
Applicable rating plug range		200 - 800A					200 - 1600A				
Mechanical make-time (ms)		35					35				
Mechanical break-time (ms)		34					34				
Electric close make-time (ms)		50					50				
Electric trip/ UV break-time (ms)		40/73					40/73				
Electric trip and reclose interval (ms)		80					80				
Mechanical duty cycles (with maint.) ¹		15,000					15,000				
Electrical duty cycles (with maint.) ¹		15,000					15,000				
Draw-out breaker efficiency (Watts loss at rated <i>I</i> _n)		85					320				
Draw-out fused breaker efficiency (Watts loss at rated <i>I</i> _n)		Consult factory					Consult factory				
Ambient operating temperature (°C)		-25 to 40					-25 to 40				
Weights (Fused Breaker/Breaker/Cradle) lbs.		227/159/112					227/159/112				

WL frame ratings – Frame size 2		2000A				3200A		
Rating Class		S	H	L	F	S	H	L
Interrupting current frame <i>I</i> _{cs} (kAIC RMS) 50/60 Hz	254VAC	65	85	100	200	65	85	100
	508VAC	65	85	100	200	65	85	100
	600VAC	—	—	—	200	—	—	—
	635VAC	65	65	85	—	65	65	85
Short-time current <i>I</i> _{cw} (kA RMS)	1 sec.	65	65	85	—	65	65	85
Close and latch rating (kA RMS)		65	65	85	—	65	65	85
Applicable rating plug range		200 - 2000A				200 - 3200A		
Mechanical make-time (ms)		35				35		
Mechanical break-time (ms)		34				34		
Electric close make-time (ms)		50				50		
Electric trip/ UV break-time (ms)		40/73				40/73		
Electric trip and reclose interval (ms)		80				80		
Mechanical duty cycles (with maint.) ¹		15,000				15,000		
Electrical duty cycles (with maint.) ¹		15,000				15,000		
Draw-out breaker efficiency (Watts loss at rated <i>I</i> _n)		700				1650		
Draw-out fused breaker efficiency (Watts loss at rated <i>I</i> _n)		Consult factory				Consult factory		
Ambient operating temperature (°C)		-25 to 40				-25 to 40		
Weights (Fused Breaker/Breaker/Cradle) lbs.		227/209/152				227/209/152		

¹ Maintenance means: replacing main contacts and arc chutes (see operating instructions).
M-Class main contacts can be replaced by Siemens personnel only.

WL Power Circuit Breaker

Ratings for UL 1066 Listed (ANSI C37) Breakers

Selection

WL frame ratings – Frame size 3		3200A		4000A				5000A			
Rating Class		M	F	H	L	M	F	H	L	M	F
Interrupting current frame /cs (kAIC RMS) 50/60 Hz	254VAC	150	200	85	100	150	200	85	100	150	200
	508VAC	150	200	85	100	150	200	85	100	150	200
	600VAC	—	200	—	—	—	200	—	—	—	200
	635VAC	85	—	85	85	85	—	85	85	85	—
Short-time current I _{cs} (kA RMS)	1 sec.	100 ²	—	85	100 ²	100 ²	—	85	100 ²	100 ²	—
Close and latch rating (kA RMS)		100 ²	—	85	100 ²	100 ²	—	85	100 ²	100 ²	—
Applicable rating plug range		800 - 3200A		800 - 4000A				800 - 5000 A			
Mechanical make-time (ms)		35		35				35			
Mechanical break-time (ms)		34		34				24			
Electric close make-time (ms)		50		50				50			
Electric trip/ UV break-time (ms)		40/73		40/73				40/73			
Electric trip and reclose interval (ms)		80		80				80			
Mechanical duty cycles (with maint.) ¹		10,000		10,000				10,000			
Electrical duty cycles (with maint.) ¹		10,000		10,000				10,000			
Draw-out breaker efficiency (Watts loss at rated I _n)		700		1100				1650			
Draw-out fused breaker efficiency (Watts loss at rated I _n)		Consult factory		Consult factory				Consult Factory			
Ambient operating temperature (°C)		-25 to 40		-25 to 40				-25 to 40			
Weights (Fused Carriage/Breaker/Cradle) lbs.		225/260/306		225/260/306				225/260/306			

Ratings for UL 1066 Listed Non-automatic Switches

WL frame ratings		Frame size 2 800A - 3200A ⁴		Frame size 3 3200 - 5000A ⁴	
Rating Class		F ³	L	F ³	L
Breaking capacity with external relay (kA RMS) 50/60 Hz, instantaneous trip	254VAC	200	100	200	100
	508VAC	200	100	200	100
	635VAC	200	85	200	85
Short-time current I _{cs} (kA RMS)	1 sec.	N/A	65	N/A	100 ²

¹ Maintenance means: replacing main contacts and arc chutes (see operating instructions).

M-Class main contacts can be replaced by Siemens personnel only. Do not apply switch or breaker rated at 635VAC to a system with fault current > 85kA RMS.

² Short-time withstand current (I_{cs}) at 635 VAC is kAIC RMS.

³ Max. 600 VAC.

⁴ 3200A frame rating is only available in L-Class in Frame Size 2. 3200A frame rating is not available in L-Class in Frame Size 3.

WL Power Circuit Breaker

UL 1066 Listed Catalogue Number

Selection

Interrupting rating, frame size, breaker type and frame rating

Note: Cradle must be ordered separately (see page 49)

Class	Interrupt rating (kA)		Frame Max ampere rating (A)	Frame size		Fuse (A)	Breaker catalog number														
	254VAC 508VAC	635VAC		2	3		1	2	3	4	5	6	7	8	9	10	11	12	13	14	15
N	50	50	800	X			N	2	A	3	0	8									
N	50	50	1600	X			N	2	A	3	1	6									
S	65	65	800	X			S	2	A	3	0	8									
S	65	65	1600	X			S	2	A	3	1	6									
S	65	65	2000	X			S	2	A	3	2	0									
S	65	65	3200	X			S	2	A	3	3	2									
H	85	65	800	X			H	2	A	3	0	8									
H	85	65	1600	X			H	2	A	3	1	6									
H	85	65	2000	X			H	2	A	3	2	0									
H	85	65	3200	X			H	2	A	3	3	2									
H	85	85	4000		X		H	3	A	3	4	0									
H	85	85	5000		X		H	3	A	3	5	0									
L	100	85	800	X			L	2	A	3	0	8									
L	100	85	1600	X			L	2	A	3	1	6									
L	100	85	2000	X			L	2	A	3	2	0									
L	100	85	3200	X			L	2	A	3	3	2									
L	100	85	4000		X		L	3	A	3	4	0									
L	100	85	5000		X		L	3	A	3	5	0									
M	150	85	3200		X		M	3	A	3	3	2									
M	150	85	4000		X		M	3	A	3	4	0									
M	150	85	5000		X		M	3	A	3	5	0									
F	200	200	800	X		400	F	2	A	3	0	A									
F	200	200	800	X		600	F	2	A	3	0	B									
F	200	200	800	X		800	F	2	A	3	0	C									
F	200	200	800	X		900	F	2	A	3	0	D									
F	200	200	800	X		1000	F	2	A	3	0	E									
F	200	200	800	X		1200	F	2	A	3	0	F									
F	200	200	800	X		1600	F	2	A	3	0	G									
F	200	200	800	X		2000	F	2	A	3	0	H									
F	200	200	800	X		2500	F	2	A	3	0	J									
F	200	200	800	X		3000	F	2	A	3	0	K									
F	200	200	1600	X		400	F	2	A	3	1	A									
F	200	200	1600	X		600	F	2	A	3	1	B									
F	200	200	1600	X		800	F	2	A	3	1	C									
F	200	200	1600	X		900	F	2	A	3	1	D									
F	200	200	1600	X		1000	F	2	A	3	1	E									
F	200	200	1600	X		1200	F	2	A	3	1	F									
F	200	200	1600	X		1600	F	2	A	3	1	G									
F	200	200	1600	X		2000	F	2	A	3	1	H									
F	200	200	1600	X		2500	F	2	A	3	1	J									
F	200	200	1600	X		3000	F	2	A	3	1	K									
F	200	200	2000	X		400	F	2	A	3	2	A									
F	200	200	2000	X		600	F	2	A	3	2	B									
F	200	200	2000	X		800	F	2	A	3	2	C									
F	200	200	2000	X		900	F	2	A	3	2	D									
F	200	200	2000	X		1000	F	2	A	3	2	E									
F	200	200	2000	X		1200	F	2	A	3	2	F									
F	200	200	2000	X		1600	F	2	A	3	2	G									
F	200	200	2000	X		2000	F	2	A	3	2	H									
F	200	200	2000	X		2500	F	2	A	3	2	J									
F	200	200	2000	X		3000	F	2	A	3	2	K									
F	200	200	3200		X	6000	F	3	A	3	3	2									
F	200	200	4000		X	6000	F	3	A	3	4	0									
F	200	200	5000		X	6000	F	3	A	3	5	0									

WL Power Circuit Breaker

UL 1066 Listed Catalogue Number

Selection

Rating plug			Breaker catalog number															
Maximum continuous current rating (A)	Frame size 2	Frame size 3	1	2	3	4	5	6	7	8	9	10	11	12	13	14	15	
200	X																	A
225	X																	B
250	X																	C
300	X																	D
315	X																	E
350	X																	F
400	X																	G
450	X																	H
500	X																	J
600	X																	K
630	X																	L
700	X																	M
800	X	X																N
1000	X	X																P
1200	X	X																Q
1250	X	X																R
1600	X	X																T
2000	X	X																U
2500	X	X																V
3000	X	X																W
3200	X	X																Y
4000		X																Z
5000		X																1

Electronic trip units (ETU)

Trip unit type	Protective function			LCD display alpha num.	Ground fault module		
	L	S	I		Alarm	Trip	
ETU745	X	(X)	(X)				C
ETU745	X	(X)	(X)	X			D
ETU745	X	(X)	(X)		X		E
ETU745	X	(X)	(X)	X	X		F
ETU745	X	(X)	(X)		X	X	G
ETU745	X	(X)	(X)	X	X	X	H
ETU748	X	X					J
ETU748	X	X		X			K
ETU748	X	X			X		L
ETU748	X	X		X	X		N
ETU748	X	X			X	X	P
ETU748	X	X		X	X	X	Q
ETU776	X	(X)	(X)				V
ETU776	X	(X)	(X)		X		W
ETU776	X	(X)	(X)		X	X	Y

() Function can be disabled by user.

WL Power Circuit Breaker

UL 1066 Listed Catalogue Number

Selection

Bell alarm, breaker ready-to-close, auxiliary contacts

Breaker catalog number

1 2 3 4 5 6 7 8 9 10 11 12 13 14 15

Bell alarm		Form C contacts	Breaker ready-to-close 1b contact	Breaker open/close auxiliary switches		None	X
Remote reset coil voltage				2a + 2b	4a + 4b		
AC	DC						
		X					A
			X				B
				X			C
					X		D
		X	X				E
		X		X			F
		X			X		G
			X	X			H
			X		X		I
		X	X	X			J
		X	X		X		K
	24	X					L
	48	X					M
120	125	X					N
240	250	X					O
	24	X	X				P
	48	X	X				Q
120	125	X	X				R
240	250	X	X				S
	24	X		X			T
	48	X		X			U
120	125	X		X			V
240	250	X		X			W
	24	X			X		Y
	48	X			X		Z
120	125	X			X		1
240	250	X			X		2
	24	X	X	X			3
	48	X	X	X			4
120	125	X	X	X			5
240	250	X	X	X			6
	24	X	X		X		7
	48	X	X		X		8
120	125	X	X		X		9
240	250	X	X		X		0

Shunt trip

Control voltage		Status contact	None	X
AC	DC			
	24			A
	48			B
120	125			C
240	250			D
	24	X		E
	48	X		F
120	125	X		G
240	250	X		H

WL Power Circuit Breaker

UL 1066 Listed Catalogue Number

Selection

Undervoltage release (with or without time delay) or 2nd shunt trip					Breaker catalog number																	
Control voltage		UVR without delay	UVR with delay	UVR status contact ¹	2nd shunt trip	1	2	3	4	5	6	7	8	9	10	11	12	13	14	15		
AC	DC					None	X	A	B	C	D	E	F	G	H	J	K	L	M	N	P	Q
	24	X																				X
	48	X																				A
120	125	X																				B
240	250	X																				C
	48		X																			D
120	125		X																			E
240	250		X																			F
	24				X																	G
	48				X																	H
120	125				X																	J
240	250				X																	K
	24	X		X																		L
	48	X		X																		M
120	125	X		X																		N
240	250	X		X																		P
	48		X	X																		Q
	125		X	X																		R
120	250		X	X																		S
																						T

Charging motor, motor switch, operations counter

Charging motor operation voltage		Motor cut-off switch	Operations counter																			
AC	DC			None	X	A	B	C	D	E	F	G	H	J	K	L	M	N	P	Q	R	
	24																					X
	48																					A
120	125																					B
240	250																					C
	24	X																				D
	48	X																				E
120	125	X																				F
240	250	X																				G
	24			X																		H
	48			X																		J
120	125			X																		K
240	250			X																		L
	24	X		X																		M
	48	X		X																		N
120	125	X		X																		P
240	250	X		X																		Q
			X	X																		R

¹ Status contact is only available when communication is not installed on breaker. Signal is sent via communication in lieu of status contact.

WL Power Circuit Breaker

UL 1066 Listed Catalogue Number

Selection

Close coil, power metering and communications

Breaker catalog number

Close coil operation voltage		Power metering capable ¹	Modbus ²	PROFIBUS ²	Breaker catalog number														
AC	DC				1	2	3	4	5	6	7	8	9	10	11	12	13	14	15
																		None	X
	24																		A
	48																		B
120	125																		C
240	250																		D
							X												G
								X											H
	24					X													N
	24								X										P
	48						X												S
	48								X										T
120	125						X												W
120	125								X										Y
240	250						X												2
240	250								X										3
	24	X				X													Q
	48	X				X													U
120	125	X				X													Z
240	250	X				X													4
	24	X							X										R
	48	X							X										V
120	125	X							X										1
240	250	X							X										5
		X				X													L
		X							X										M
		X																	F
	24	X																	6
	48	X																	7
120	125	X																	8
240	250	X																	9

Breaker locks

Key lock breaker OPEN position (lock type – KIRK) ³	Key lock breaker OPEN position (lock type – SUPERIOR) ³	Padlock provisions for OPEN and CLOSE pushbuttons ⁴	Padlock provisions for charging handle ⁴	Breaker catalog number																
																			None	X
X																				A
						X														C
									X											E
	X																			F
X						X														G
	X					X														J
X									X											S
	X								X											U
						X			X											V
X						X			X											W
	X					X			X											Z

Miscellaneous options⁵

Key lock breaker OPEN position (provision only) ⁴	Manual trip reset ETU (Automatic trip reset is standard)	Breaker catalog number																		
																			None	N
X																				B
						X														C
X						X														D

¹ Requires External PTs for voltage input and 24VDC power supply.

² Includes BSS device and requires 24VDC power supply.

³ Custom key locks are not available and must be supplied by others. Order key lock provision if custom if keyed alike locks are required.

⁴ Locks provided by others.

⁵ If a breaker lock is chosen for Digit 14, a provision need not be ordered in Digit 15.

WL Power Circuit Switch

UL 1066 Listed Non-automatic Catalogue Number

Selection

Breaking capacity, frame size, switch type and frame rating

Class	Breaking capacity (kA)		Frame Max ampere rating (A)	Frame size		Fuse (A)	Switch catalog number														
	240VAC 480VAC	600VAC		2	3		1	2	3	4	5	6	7	8	9	10	11	12	13	14	15
L	100	85	800	X			L	2	S	3	0	8	S	S							
L	100	85	1600	X			L	2	S	3	1	6	S	S							
L	100	85	2000	X			L	2	S	3	2	0	S	S							
L	100	85	3200	X			L	2	S	3	2	2	S	S							
L	100	85	4000		X		L	3	S	3	4	0	S	S							
L	100	85	5000		X		L	3	S	3	5	0	S	S							
F	200	200	800	X		1000	F	2	S	3	0	E	S	S							
F	200	200	800	X		1200	F	2	S	3	0	F	S	S							
F	200	200	800	X		1600	F	2	S	3	0	G	S	S							
F	200	200	800	X		2000	F	2	S	3	0	H	S	S							
F	200	200	800	X		2500	F	2	S	3	0	J	S	S							
F	200	200	800	X		3000	F	2	S	3	0	K	S	S							
F	200	200	1600	X		1000	F	2	S	3	1	E	S	S							
F	200	200	1600	X		1200	F	2	S	3	1	F	S	S							
F	200	200	1600	X		1600	F	2	S	3	1	G	S	S							
F	200	200	1600	X		2000	F	2	S	3	1	H	S	S							
F	200	200	1600	X		2500	F	2	S	3	1	J	S	S							
F	200	200	1600	X		3000	F	2	S	3	1	K	S	S							
F	200	200	2000	X		1000	F	2	S	3	2	E	S	S							
F	200	200	2000	X		1200	F	2	S	3	2	F	S	S							
F	200	200	2000	X		1600	F	2	S	3	2	G	S	S							
F	200	200	2000	X		2000	F	2	S	3	2	H	S	S							
F	200	200	2000	X		2500	F	2	S	3	2	J	S	S							
F	200	200	2000	X		3000	F	2	S	3	2	K	S	S							
F	200	200	3200		X	6000	F	3	S	3	3	2	S	S							
F	200	200	4000		X	6000	F	3	S	3	4	0	S	S							
F	200	200	5000		X	6000	F	3	S	3	5	0	S	S							

WL Power Circuit Switch

UL 1066 Listed Non-automatic Catalogue Number

Selection

Breaker ready-to-close auxiliary contacts

Breaker ready-to-close auxiliary contacts			Switch catalog number																	
Breaker ready-to-close		Breaker open/close auxiliary switches		1	2	3	4	5	6	7	8	9	10	11	12	13	14	15		
1b contact	2a + 2b	4a + 4b		None									X							
X																				B
	X																			C
		X																		D
X	X																			H
X		X																		I

Shunt trip

Operation voltage		Status contact		
AC	DC			
			None	X
	24			A
	48			B
120	125			C
240	250			D
	24	X		E
	48	X		F
120	125	X		G
240	250	X		H

Undervoltage release (with or without time delay) or 2nd shunt trip

Operation voltage		UVR without delay	UVR with delay	UVR status contact ¹	2nd shunt trip		
AC	DC						
						None	X
	24	X					A
	48	X					B
120	125	X					C
240	250	X					D
	48		X				E
120	125		X				F
240	250		X				G
	24				X		H
	48				X		J
120	125				X		K
240	250				X		L
	24	X		X			M
	48	X		X			N
120	125	X		X			P
240	250	X		X			Q
	48		X	X			R
	125		X	X			S
120	250		X	X			T

¹ Status contact only available when communication is not installed. Signal is sent via communication in lieu of status contact.

WL Power Circuit Switch

UL 1066 Listed Non-automatic Catalogue Number

Selection

Charging motor, motor switch, operations counter

Switch catalog number

1 2 3 4 5 6 7 8 9 10 11 12 13 14 15

Charging motor operation voltage		Motor cut-off switch	Operations counter		
AC	DC				
				None	X
	24				A
	48				B
120	125				C
240	250				D
	24	X			E
	48	X			F
120	125	X			G
240	250	X			H
	24		X		J
	48		X		K
120	125		X		L
240	250		X		M
	24	X	X		N
	48	X	X		P
120	125	X	X		Q
240	250	X	X		R

Close coil, communications

Close coil operation voltage		Modbus ¹	PROFIBUS ¹		
AC	DC				
				None	X
		X			G
	24				A
	24	X			N
	48				B
	48	X			S
120	125				C
120	125	X			W
240	250				D
240	250	X			2
			X		H
	24		X		P
	48		X		T
120	125		X		Y
240	250		X		3

¹ Requires 24VDC power supply. BSS is included.

WL Power Circuit Switch

UL 1066 Listed Non-automatic Catalogue Number

Selection

Switch locks				Switch catalog number														
				1	2	3	4	5	6	7	8	9	10	11	12	13	14	15
Key lock breaker OPEN position (lock type – KIRK) ¹	Key lock breaker OPEN position (lock type – SUPERIOR) ¹	Padlock provisions for OPEN and CLOSE pushbuttons ²	Padlock provisions for charging handle	None														X
X		X																A
			X															C
	X																	E
X		X																F
	X	X																G
X			X															J
	X																	S
		X	X															U
		X	X															V
X		X	X															W
	X	X	X															Z

Miscellaneous options³

Key lock breaker OPEN position (provision only) ²	None														N
X															B

UL 1066 Listed Accessories

External accessories	Catalog number
Single phase CTs for metering, 5A secondary	
Ratings – 800:5	WLG800NMCT23
Ratings – 1600:5	WLG1600NMCT23
Ratings – 2000:5	WLG2000NMCT23
Ratings – 3200:5	WLG3200NMCT23
Ratings – 4000:5	WLG4000NMCT23
Ratings – 5000:5	WLG5000NMCT23
Modified differential ground fault	
Modified differential GF (FS2 1200:1) Phase CT	WLGMDGFCT2
Modified differential GF (FS3 1200:1) Phase CT	WLGMDGFCT3
Modified differential GF (FS2, FS3 1200:1) Neutral CT	WLNCT3CB
4-wire residual ground fault sensor	
Without copper bus adapters (pass-thru mount) - for 3" max bus bar	WLNCT2
Without copper bus adapters (pass-thru mount) - for 3 - 5" max bus bar	WLNCT3
With copper bus adapters for bus bar connection - for 3" max bus bar	WLNCT2CB
With copper bus adapters for bus bar connection - for 3 - 5" max bus bar	WLNCT3CB
Internal replacement current sensor kit	
Frame Size 2 Breaker	WLCT2
Frame Size 3 Breaker	WLCT3
Miscellaneous external accessories	
Crimp lugs for 10#AWG secondary wiring (package of 70)	WL10RL
Auxiliary contact on drawout breaker (knife block)	WLCNMD
24V DC trip unit and communications power supply, 2.5A SITOP power, class 2	WLSITOP25
24V DC trip unit and communications power supply, 3.8A SITOP power, class 2	WLSITOP1

¹ Custom key locks are not available and must be supplied by others. Order Key Lock Provisions if custom keys or keyed alike breakers are required.

² Lock provided by others.

³ If a breaker lock is chosen for Digit 14, a provision need not be ordered in Digit 15.

WL Power Circuit Switch

UL 1066 Listed Cradle Catalogue Number

Selection

Interrupting rating, frame size and frame rating

Class	Interrupt rating (kA)		Frame Max ampere rating (A)	Frame size		Cradle catalog number															
	240VAC	600VAC		2	3	G	2	3	4	5	6	7	8	9	10	11	12	13	14	15	
	480VAC																				
N	50	50	800	X				N	2	3	0	8									
N	50	50	1600	X				N	2	3	1	6									
S	65	65	800	X				S	2	3	0	8									
S	65	65	1600	X				S	2	3	1	6									
S	65	65	2000	X				S	2	3	2	0									
S	65	65	3200	X				S	2	3	3	2									
H	85	65	800	X				H	2	3	0	8									
H	85	65	1600	X				H	2	3	1	6									
H	85	65	2000	X				H	2	3	2	0									
H	85	65	3200	X				H	2	3	3	2									
H	85	85	4000		X			H	3	3	4	0									
H	85	85	5000		X	X		H	3	3	5	0									
L	100	85	800	X				L	2	3	0	8									
L	100	85	1600	X				L	2	3	1	6									
L	100	85	2000	X				L	2	3	2	0									
L	100	85	3200	X				L	2	3	3	2									
L	100	85	4000		X			L	3	3	4	0									
L	100	85	5000		X	X		L	3	3	5	0									
M	150	85	3200		X			M	3	3	3	2									
M	150	85	4000		X			M	3	3	4	0									
M	150	85	5000		X	X		M	3	3	5	0									
F	200	200	800	X				F	2	3	0	8									
F	200	200	1600	X				F	2	3	1	6									
F	200	200	2000	X				F	2	3	2	0									
F	200	200	3200		X			F	2	3	3	2									
F	200	200	4000		X	X		F	3	3	4	0									
F	200	200	5000		X	X		F	3	3	5	0									

Type of secondary terminal connection ¹

For Breakers:

Screw clamp terminals	P
Spring clamp terminals	T
Ring terminals	R
Screw clamp terminals (low profile, non-partable design)	K

For Switch (Non-automatic):

Screw clamp terminals	D
Spring clamp terminals	E
Ring terminals	F
Screw clamp terminals, non-partable design)	M

Truck Operated Contacts (TOC)

Breaker position switches in the following configurations:

None	X
(1) Connected, (1) Test, (1) Disconnected - all Form C	1
(3) Connected, (2) Test, (1) Disconnected - all Form C	3
(6) Connected - all Form C	6

Cradle mounted key locks ²

None	X
Lock breaker in OPEN position (Kirk key)	A
Lock breaker in OPEN position (Superior key)	B
Double lock breaker in OPEN position (Kirk key)	C
Double lock breaker in OPEN position (Superior key)	D
Provision only - Lock breaker in OPEN position	E
Provision only - Double lock breaker in OPEN position	F

Primary conductor isolation shutter

None	X
Isolation Shutters	F

¹ Terminal blocks (X5, X6, X8, X9) are installed as standard.

² Fused Frame Size 3 circuit breakers include a two cylinder provision as standard, with the second position pre-populated with a key-interlock to prevent racking (in or out) of the separately-mounted fuse carriage while the associated fused circuit breaker is closed.

WL Power Circuit Breaker Cradles

UL 1066 Listed Cradle Catalog Number

Selection

			Cradle catalog number														
			G	2	3	4	5	6	7	8	9	10	11	12	13	14	15
Arc chute covers																	
None													X				
Arc chute covers (FS2 only – Except Class F)													A				
Arc chute covers (FS3 only – Except Class F and M)													B				
Door locks and mechanical interlock																	
1. Mechanical interlock with 2.0 meter Bowden cable																	
2. Locks cubicle door, when breaker is in connect position (FS2 and FS3)																	
3. Locks against racking breaker if the cubicle door is open (FS2 and FS3)																	
1	2	3															
None														X			
X														M			
X				X										A			
X						X								C			
X				X										D			
X				X		X								E			
X						X								G			
X				X		X								H			
Mechanism Operated Contacts (MOC)																	
Breaker open/close auxiliary switches (4a & 4b) in the following positions:																	
None															X		
Test and Connect position (FS2 only)															M		
Connect position (FS2 only)															N		
Test and Connect position (FS3 only)															P		
Connect position (FS3 only)															Q		
Connector and heater options																	
Standard rear connectors																X	
Standard rear connectors and a cradle heater																H	
Rotatable rear connectors (FS2, 2000A and below, N, S, & H Class)																J	
Rotatable rear connectors and a cradle heater (FS2, 2000A and below, N, S, & H Class)																K	
Future use																	
Placeholder (required)																	N

UL 1066 Listed accessories

Cradle accessories		Catalog Number
3-phase metering CTs, cradle mounted (3 windows per CT)		
FS2	Ratings – 800:5	WLG8005MCT2
	Ratings – 1600:5	WLG16005MCT2
	Ratings – 2000:5	WLG20005MCT2
	Ratings – 3200:5	WLG32005MCT2
	Ratings – 4000:5	WLG40005MCT2
FS3	Ratings – 3200:5	WLG32005MCT3
	Ratings – 4000:5	WLG40005MCT3
	Ratings – 5000:5	WLG50005MCT3

WL Breaker

Application Data

General

WL Secondary Terminal Assignments

	Internal	Terminals	External	
		X9		
Bell alarm / trip signaling		14		
		13		
		12		
		11		
Signaling switch, 2nd auxiliary release Local electric close		10		
		9		L / (+) Control power signal
		8		
Signaling switch, 1st auxiliary release		7		
Signal switch, open fuse lockout		6		
		5		
Maglatch for open fuse lockout (FS III fused only)		4		X9.4 Fuse carriage FSIII
		3		X9.3
		2		L / (+) Control power signal
2nd shunt trip		1		N / (+)
		X8		
Remote reset bell alarm & tripped indicator		14		L / (+) Control power signal
		13		N / (-)
GF sensor S2		12		
GF sensor S1		11		
N sensor S2		10		Short terminals, if no N sensor
N sensor S1		9		
External voltage transformer COM		8		Phase A For use with 120V AC
External voltage transformer L3		7		Phase B secondary voltage transformers
External voltage transformer L2		6		Phase C
External voltage transformer L1		5		
0 V d.c.		4		24 V d.c. input
Control Power 24 V d.c.		3		
CUB +		2		Termination resistor, 120 Ω, 0.5 W
CUB -		1		if no external CB Module connected
COM15/16, otherwise no connection		X7		
		X6		
1st Shunt Trip		14		L / (+) Control power signal
		13		N / (-)
Aux switch, N.O., 52a, S1		12		
Aux switch, N.C., 52b, S1		11		
		10		
		9		
Closing coil		8		N / (-)
"Ready-to-close" signal		7		L / (+) Control power signal
		6		
		5		
Aux switch, N.O., 52a, S2		4		
Aux switch, N.C., 52b, S2		3		
		2		
		1		
		X5		
Emergency open via UVR		14		Breaker will open if X5-13 and X5-14 are not connected or opened by an emergency open signal, if a UVR is installed
UVR		13		
UVR		12		L / (+) Control power signal
		11		N / (-)
Aux switch, N.O., 52a, S3		10		
		9		
Aux switch, N.C., 52b, S3		8		
		7		
Aux switch, N.O., 52a, S4		6		
		5		
Aux switch, N.C., 52b, S4		4		
		3		
Charging motor Motor cut-off switch		2		L / (+) Control power signal
		1		N / (-)

WL Breaker

General Wiring

Schematic

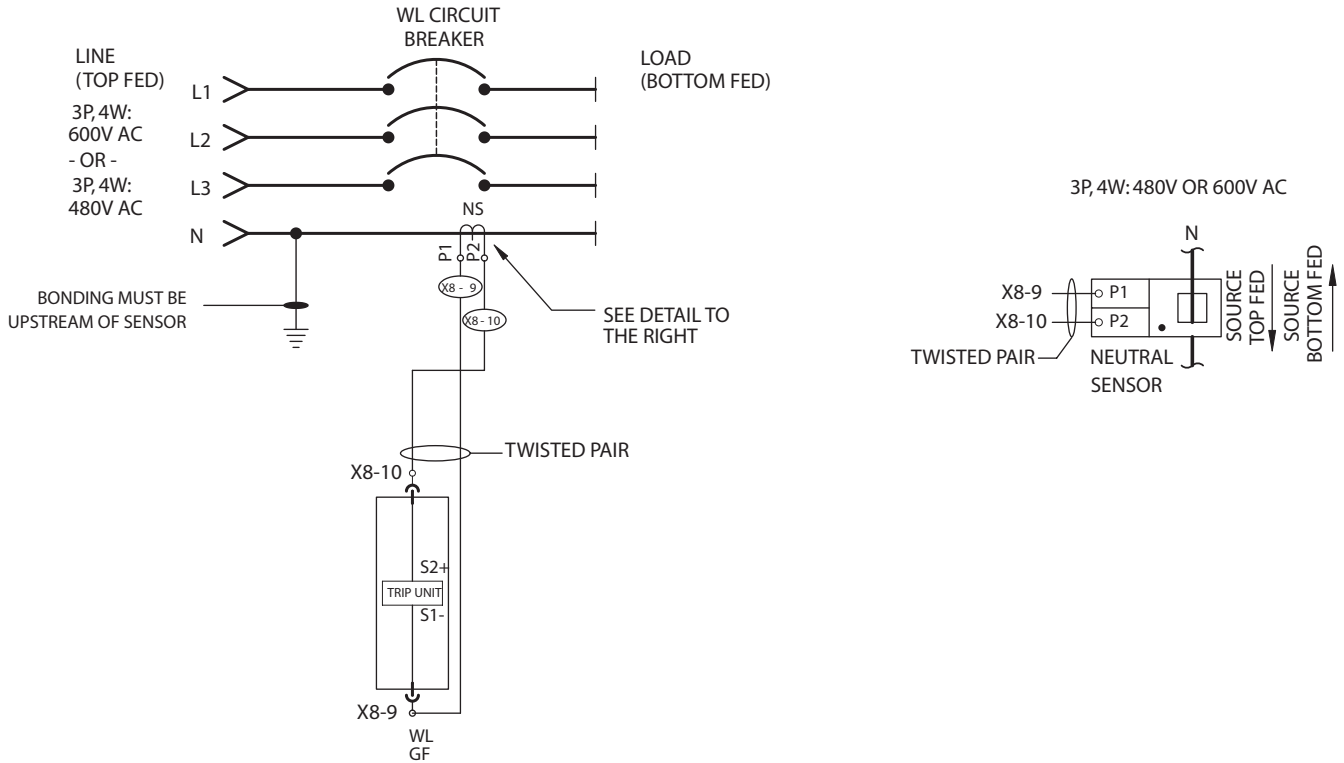

6
WL POWER
CIRCUIT BREAKERS

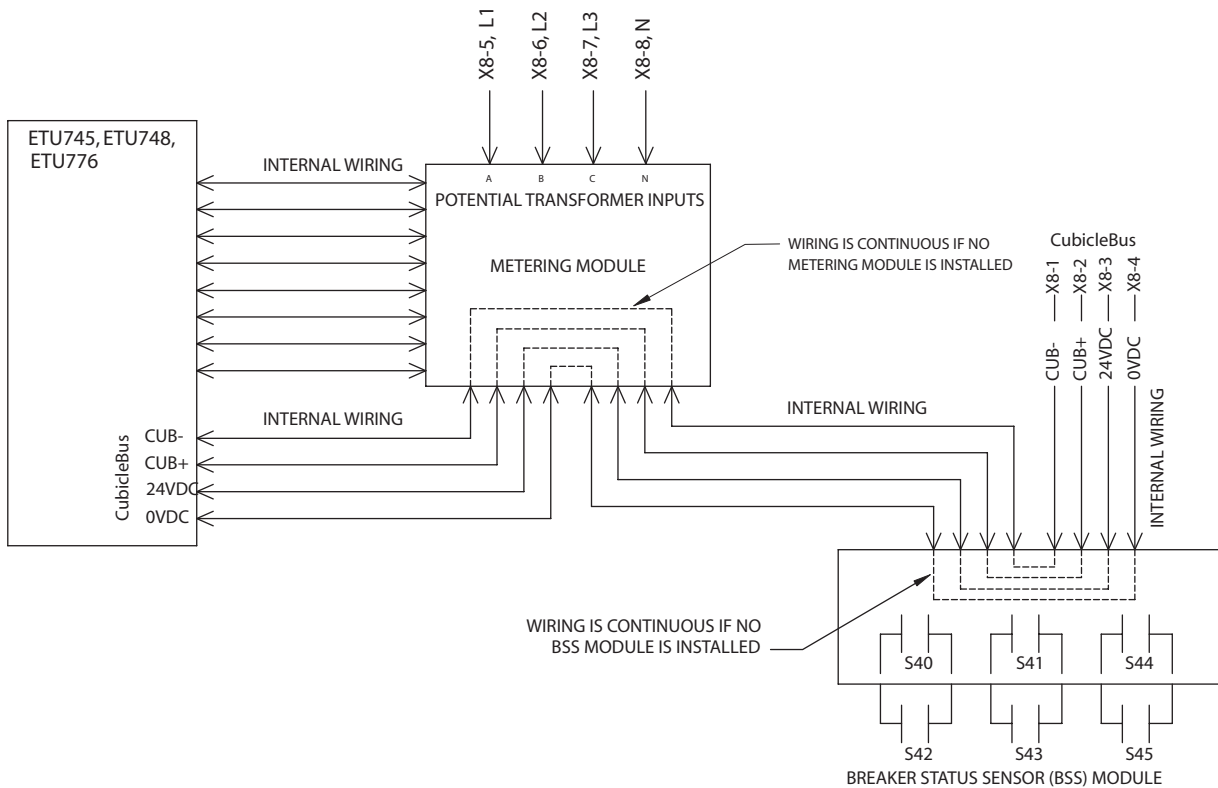

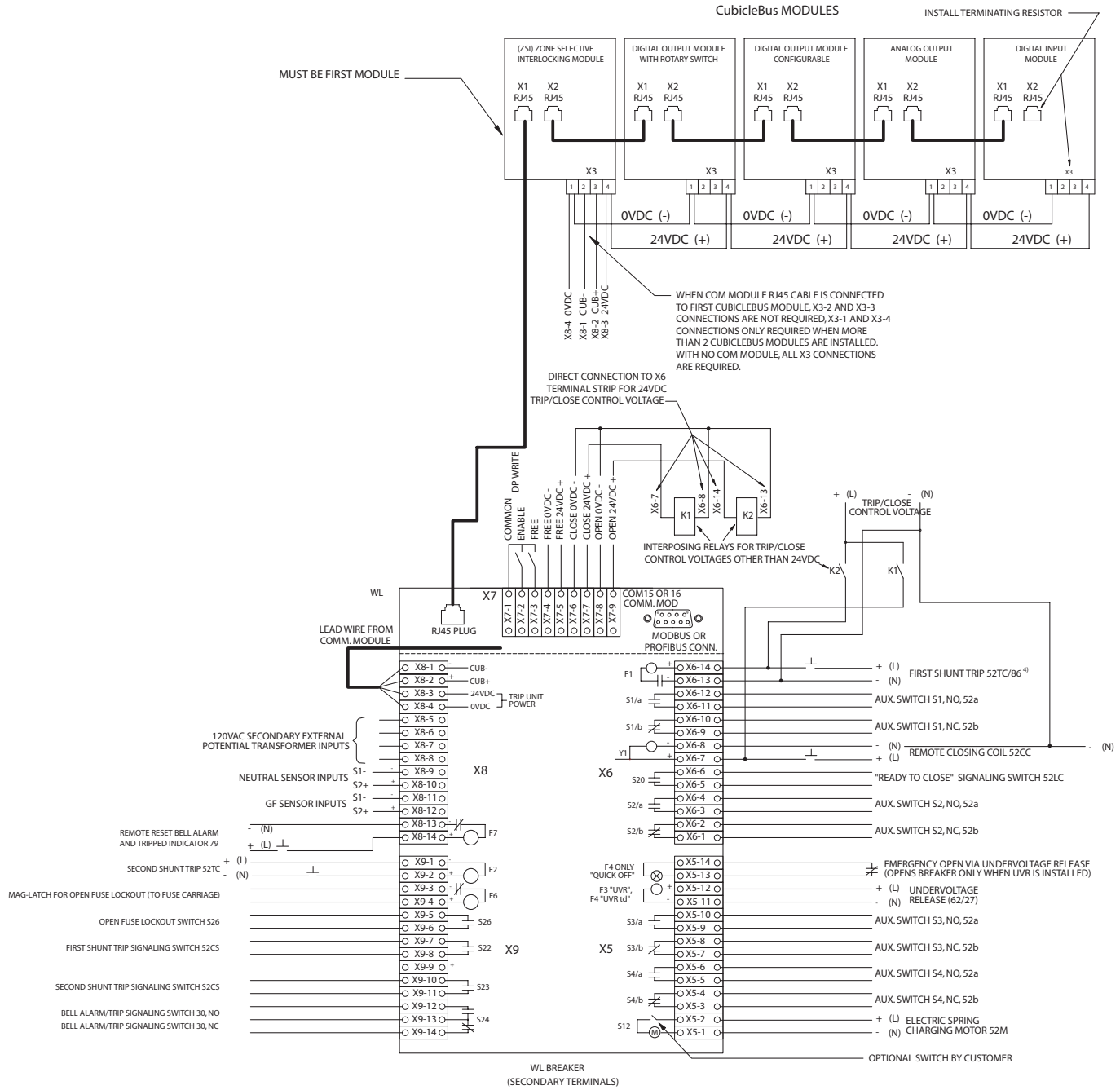

- NOTES:
1. COMPONENT PLACEMENT PER PANEL, SWITCHGEAR, OR SWITCHBOARD DRAWINGS.
 2. ALL DEVICES SHOWN IN OPEN AND/OR DE-ENERGIZED STATE.
 3. ALL GROUND FAULT WIRING TO BE SHIELDED TWISTED PAIR
 4. SHUNT TRIP CLEARING CONTACT ONLY WITH INTERMITTENT-DUTY SHUNT TRIPS ON FIRST SHUNT TRIP ONLY

WL Breaker

Ground Fault Setting

Selection

Ground Fault Protection

When optional ground fault is selected, the trip unit detects fault currents that flow to ground and represent a fire hazard to the system. The adjustable time delay allows selective staggering of consecutively arranged circuit breakers.

When setting the parameters of the trip unit, a selection can be made between the alarm and trip if the set current value is exceeded. The cause of the trip is displayed on an LED when the query button is pressed.

Modules

The trip unit versions ETU745, ETU748, and ETU776 can be retrofitted with a ground fault protection module.

Two versions of the optional ground fault module can be ordered:

- Trip and Alarm
- Alarm only

Ground Fault Measuring Methods

Residual sensing of the ground fault current

A current transformer with the transformer ratio 1200A : 1A is used to measure the ground fault current. The transformer can be installed directly in the grounded star point of a transformer.

Setting

The ground fault module can be set depending on the measuring method (see above):

Measuring method 1: in position sum I
Measuring method 2: in position G.

With trip unit ETU776, this setting is implemented via the display and key pad or communications.

Ground Fault Protection with I^2t Characteristic Curve

All versions of the ground fault modules are delivered with an I^2t or fixed delay.

Modules are available in either Alarm only or Alarm and Trip functions.

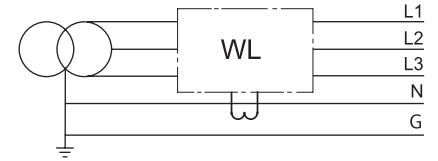

Residual sensing of the ground fault current

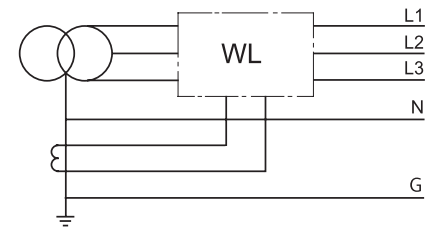

Direct measurement of the ground fault current

6

WL POWER
CIRCUIT BREAKERS

The trip unit calculates the ground fault current by vectorial current summation of the 3-phase currents and the neutral conductor current. Direct measurement of the ground fault current.

Ground fault module GFM A 745-748

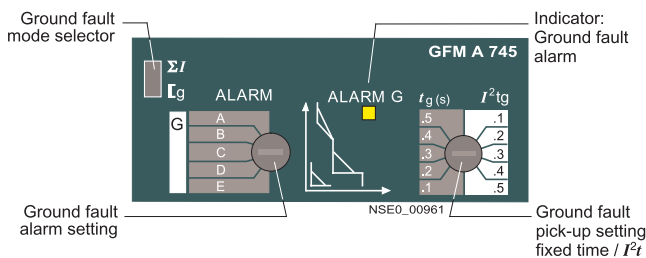

Ground fault module GFM AT 745-748

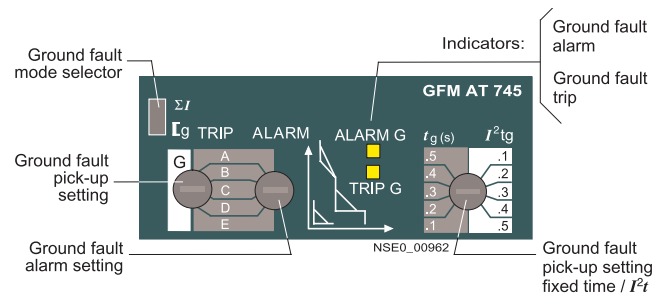

Ground fault module GFM A 776

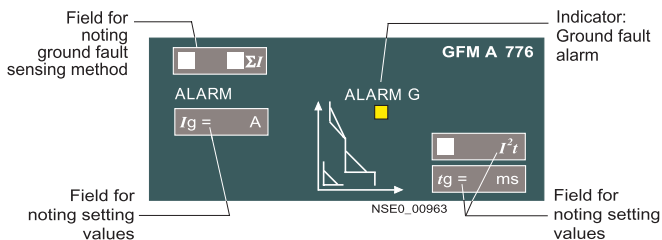

Ground fault module GFM AT 776

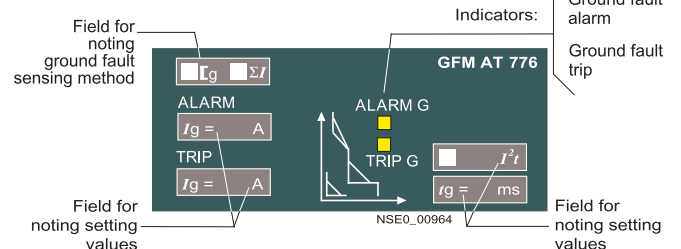

WL Breaker

Metering Voltage Details

Selection

VT / PT connections for the WL Breaker when equipped with metering WL power metering ("Meter Function") can accept 3W or 4W (LL/LN) system voltage connections.

The trip unit settings available are:

- 1) VT Primary Voltage (240V, 480V, 600V)
- 2) VT Secondary Voltage (100V, 110V, 120V)
- 3) VT Connection (Wye / LN, Delta / LL)

Three VTs must be used at all times.

All three VTs should be rated for the nominal system L-L voltage (e.g. 480V) and may have either 100V, 110V or 120V secondary voltages.

The following ratios are suggested or equivalent VTs can be used: (Must be supplied by others)

- 240:120 = 2:1 (ITI Part # 460-240 or 468-240)
- 480:120 = 4:1 (ITI Part # 460-480 or 468-480)
- 600:120 = 5:1 (ITI Part # 460-600 or 468-600)

VT Accuracy:

Each Metering Module presents a purely resistive (unity power factor) load to the transformer. Assuming no other devices connected to the VT, a ITI type 486 VT can safely feed 10 metering modules and still maintain 0.6% accuracy assuming the wiring from the VT to the individual metering modules is twisted pair and kept to a minimum length.

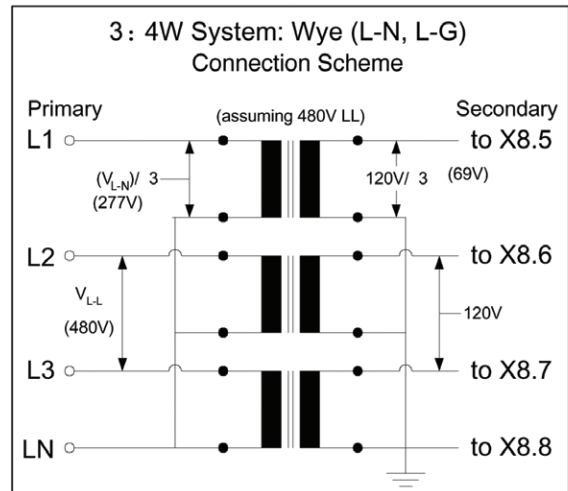
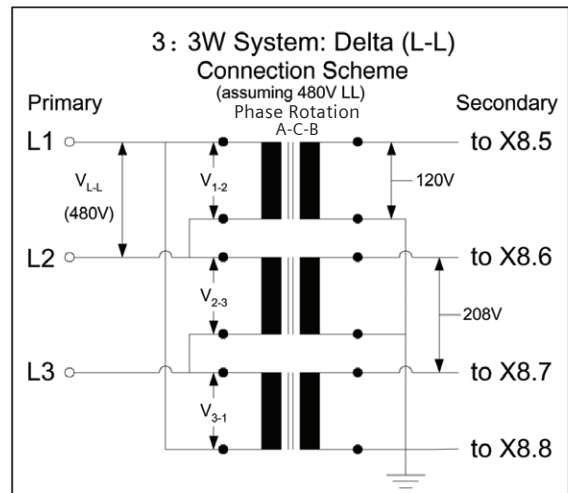
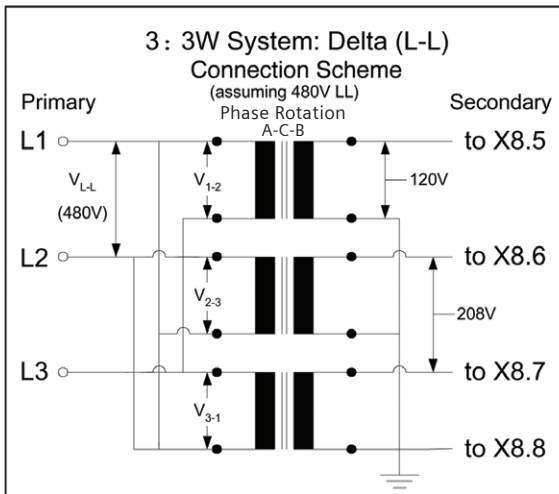

Low Voltage Circuit Breaker

UL489 Fixed-mount Breaker

Dimensions

Frame size 1

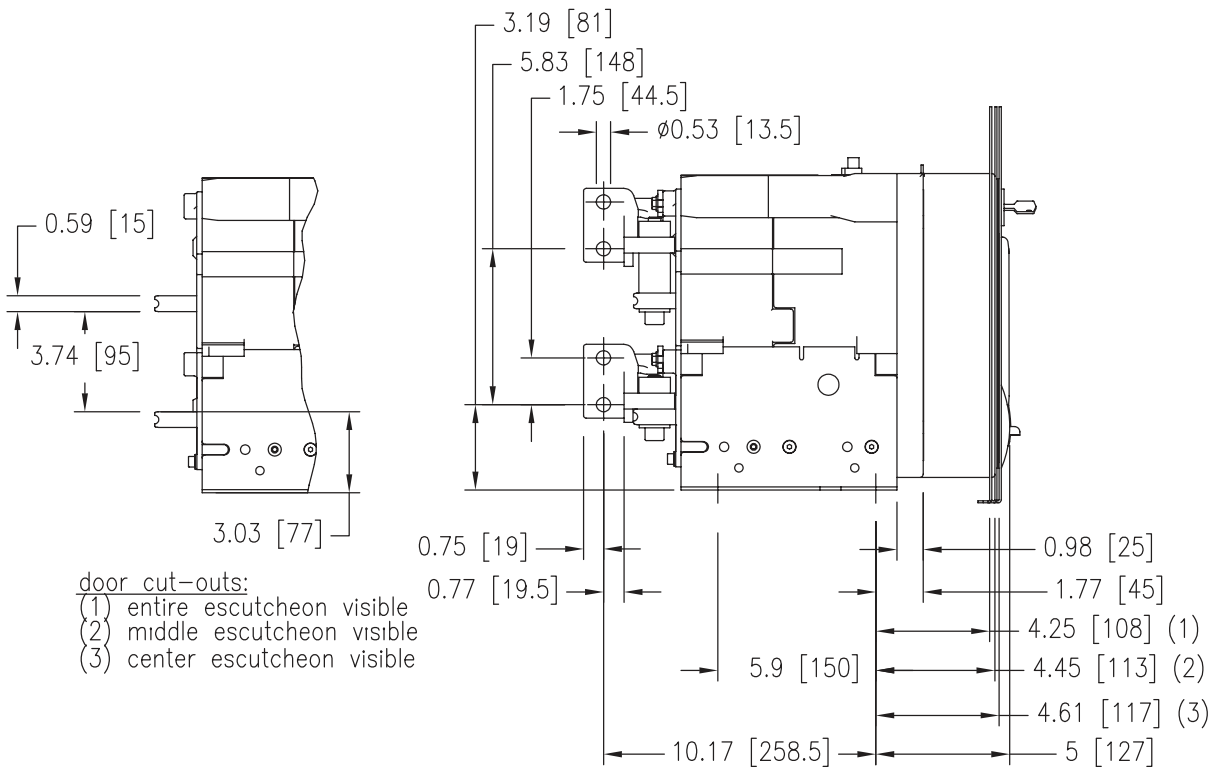
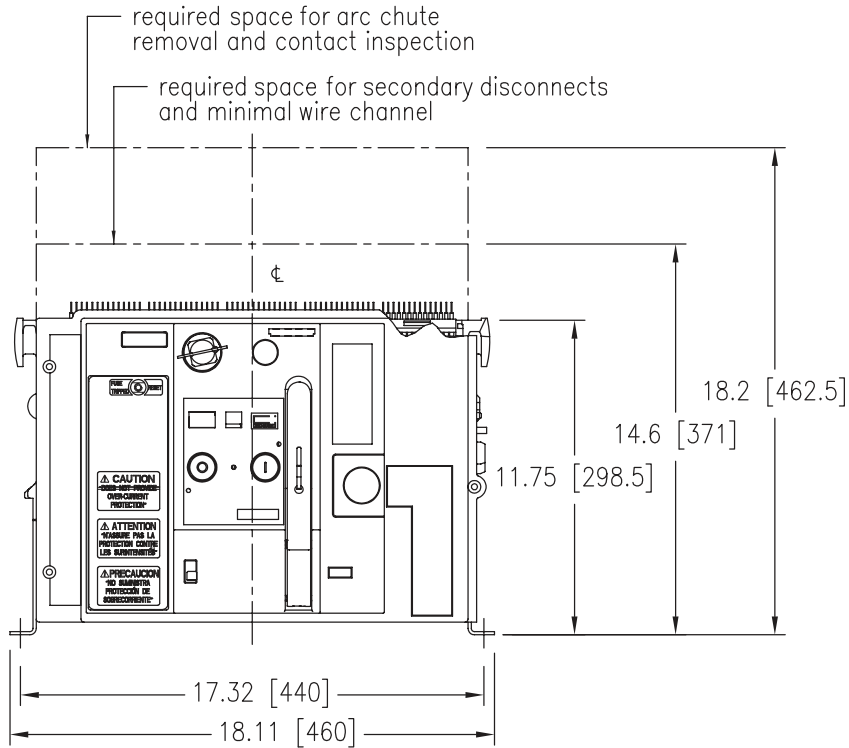

Low Voltage Circuit Breaker

UL489 Fixed-mount Breaker

Dimensions

Frame size 1
Horizontal Connectors

Top view

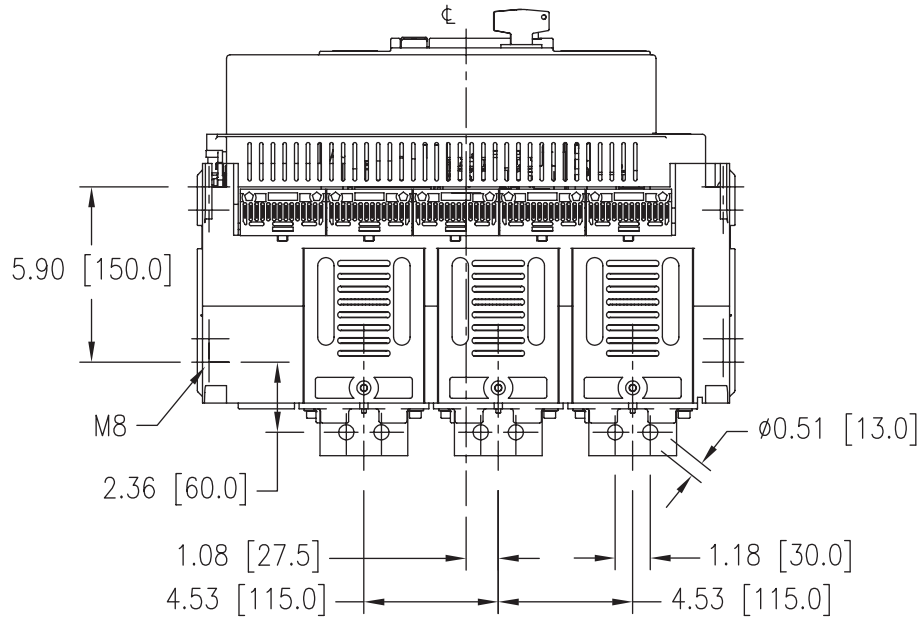

Bottom view

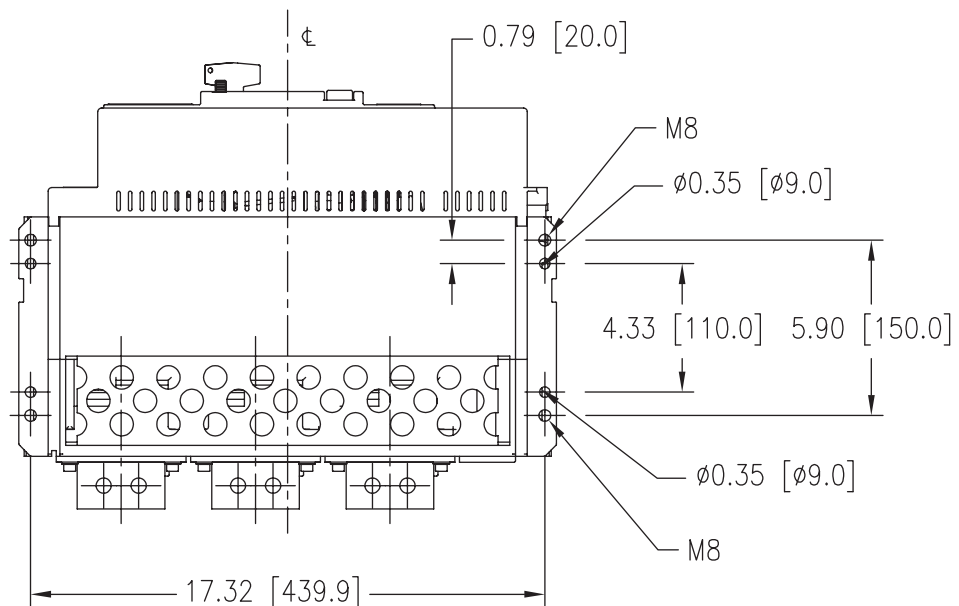

Low Voltage Circuit Breaker

UL489 Fixed-mount Breaker

Dimensions

Frame Size 1
Rear Vertical Connectors

Top view

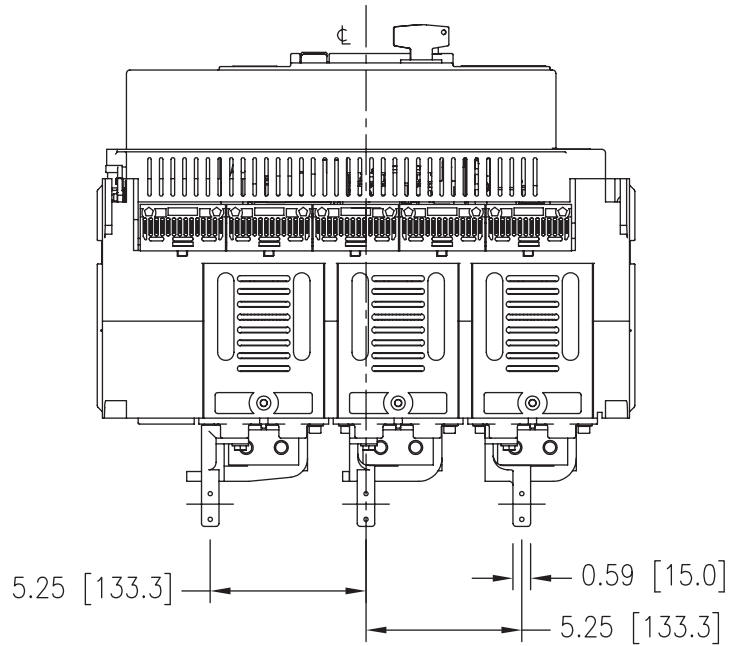

Rear view

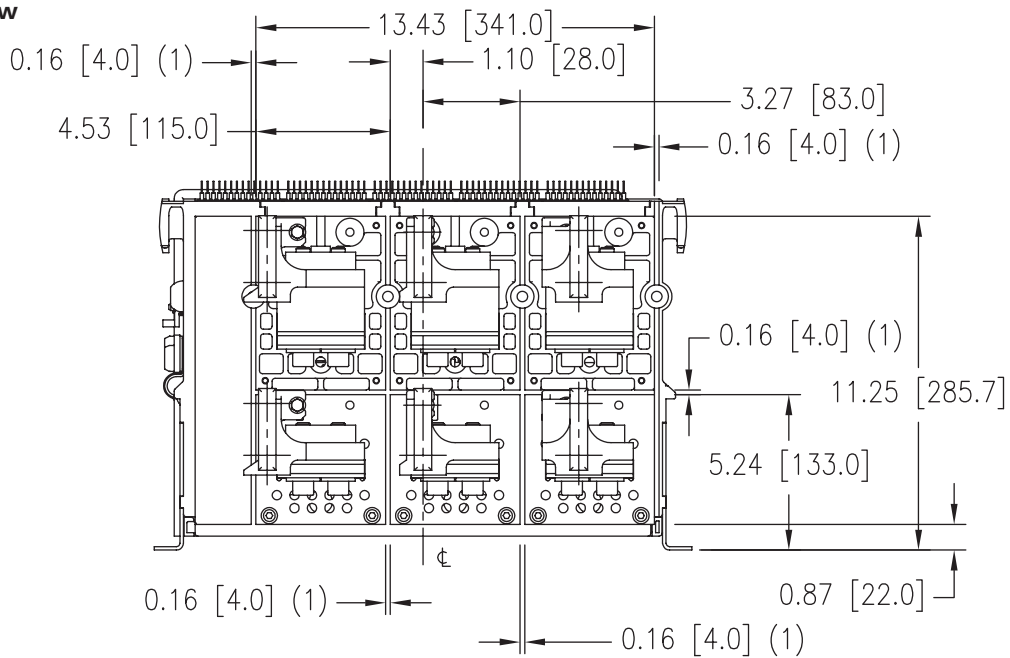

(1) = slots for insulation barriers

Low Voltage Circuit Breaker

UL489 Fixed-mount Breaker

Dimensions

Frame Size 1
Front Connectors

Top view

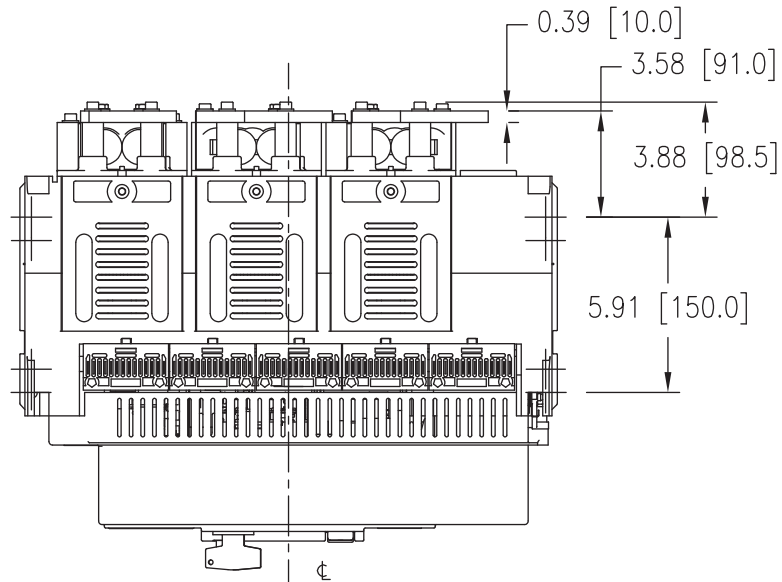

Front view

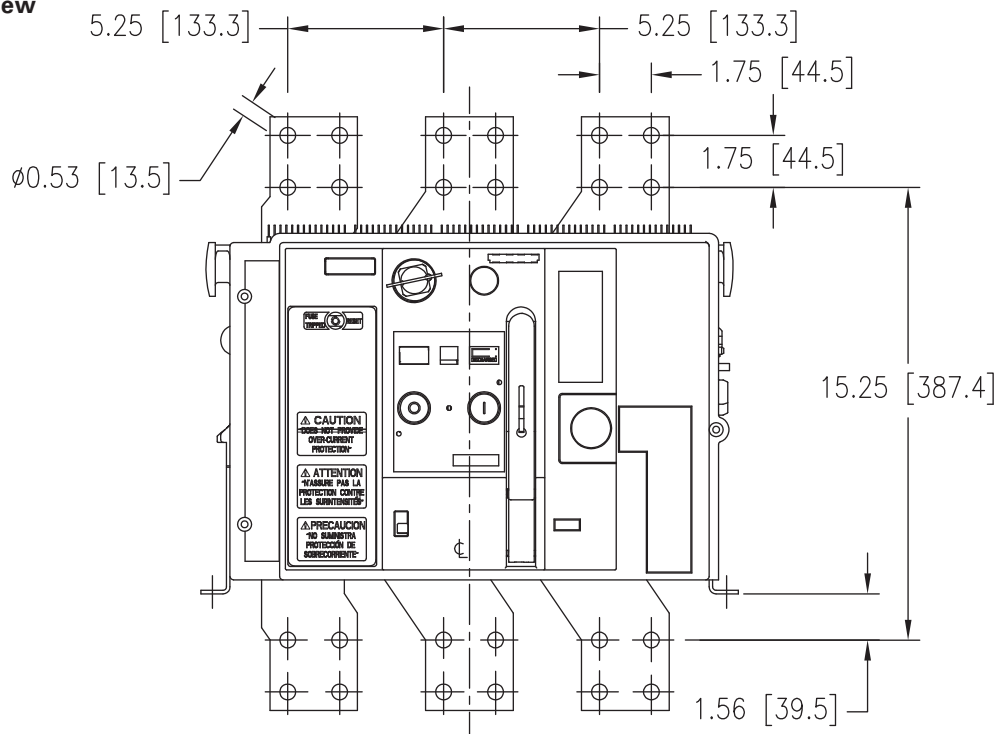

Low Voltage Circuit Breaker

UL489 Fixed-mount Breaker

Dimensions

Frame Size 1

Front Connectors and Lugs

Top view

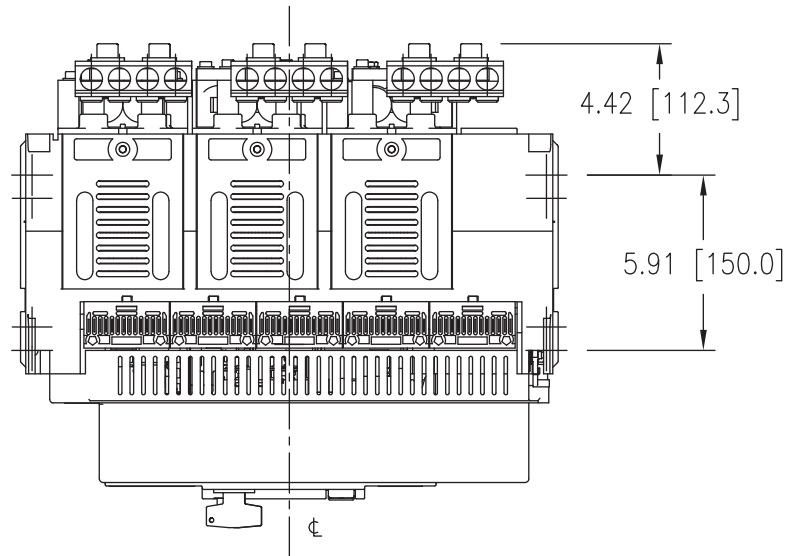

Front view

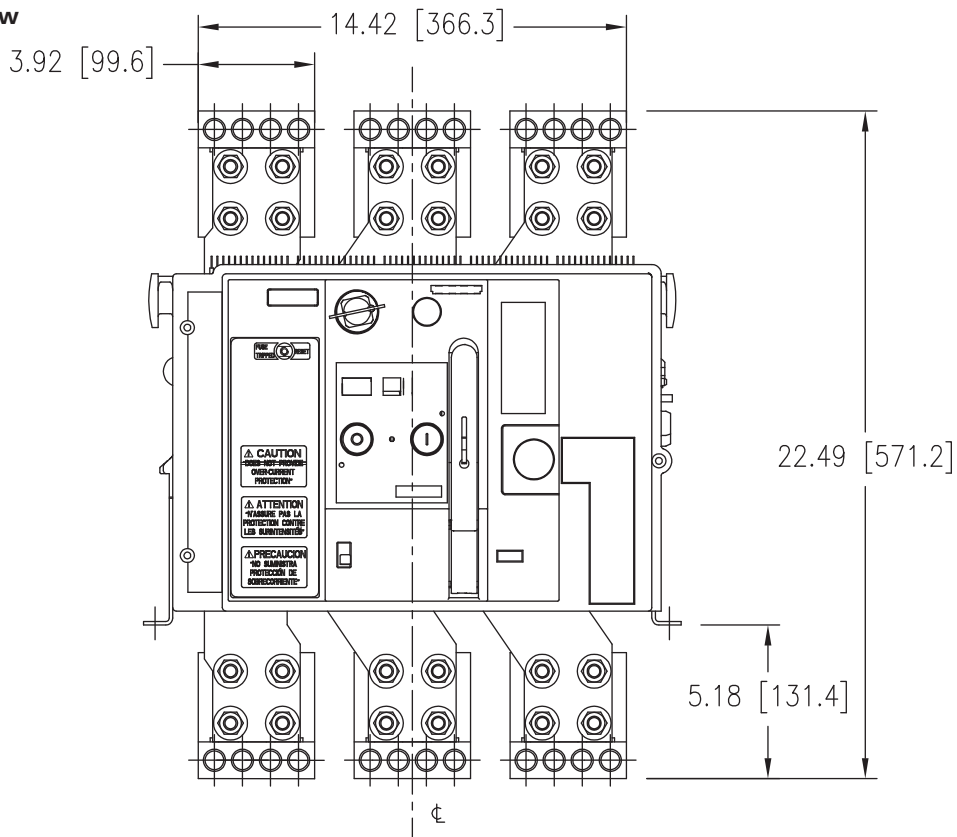

Low Voltage Circuit Breaker

UL489 Fixed-mount Breaker

Dimensions

Fixed Size 1

Door Cut-outs

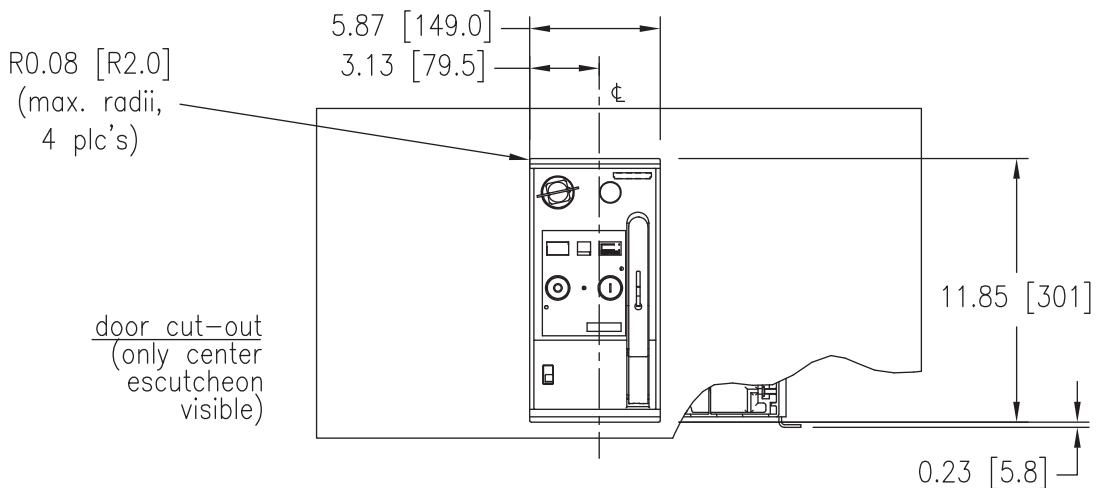
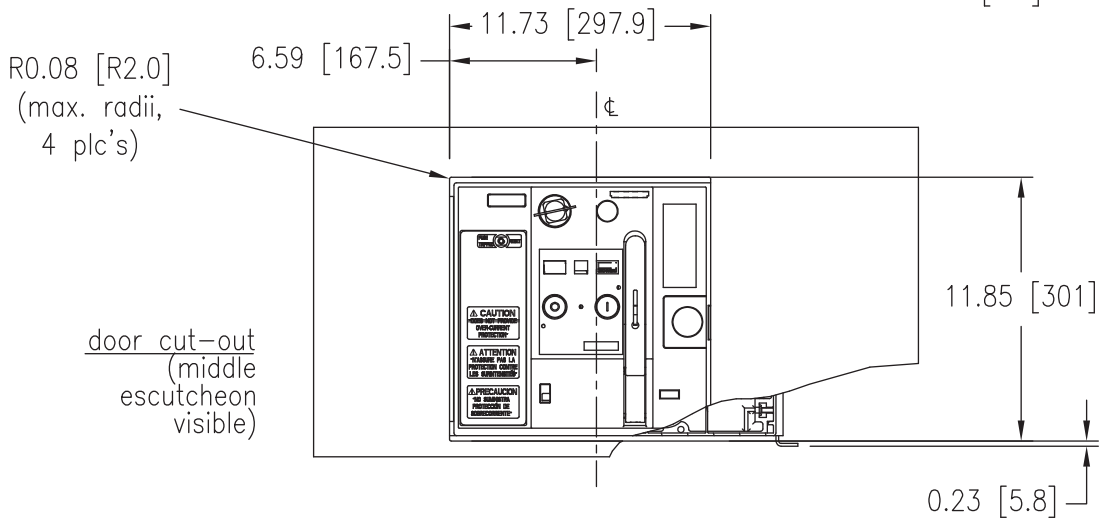
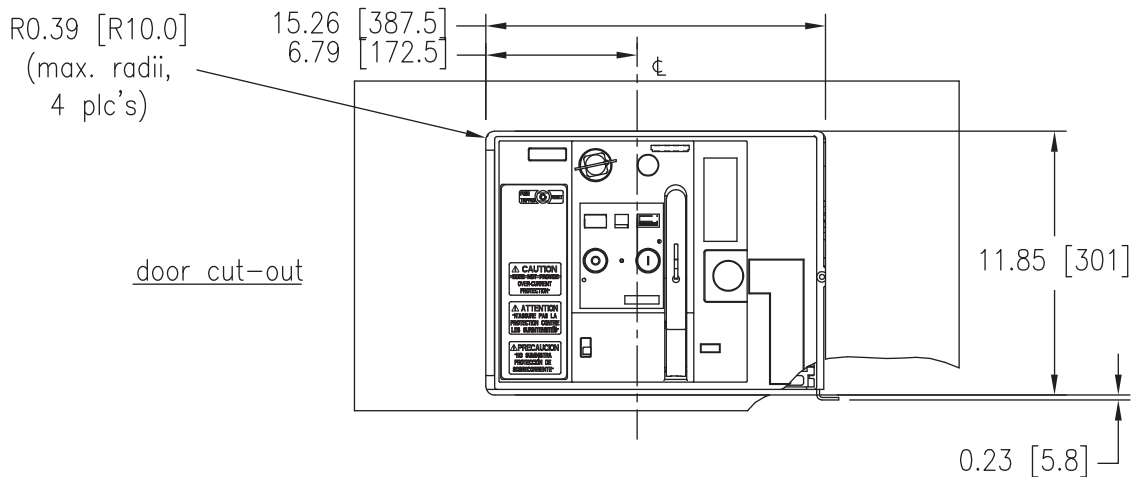

Low Voltage Circuit Breaker

UL489 Fixed-mount Breaker

Dimensions

Frame Size 2

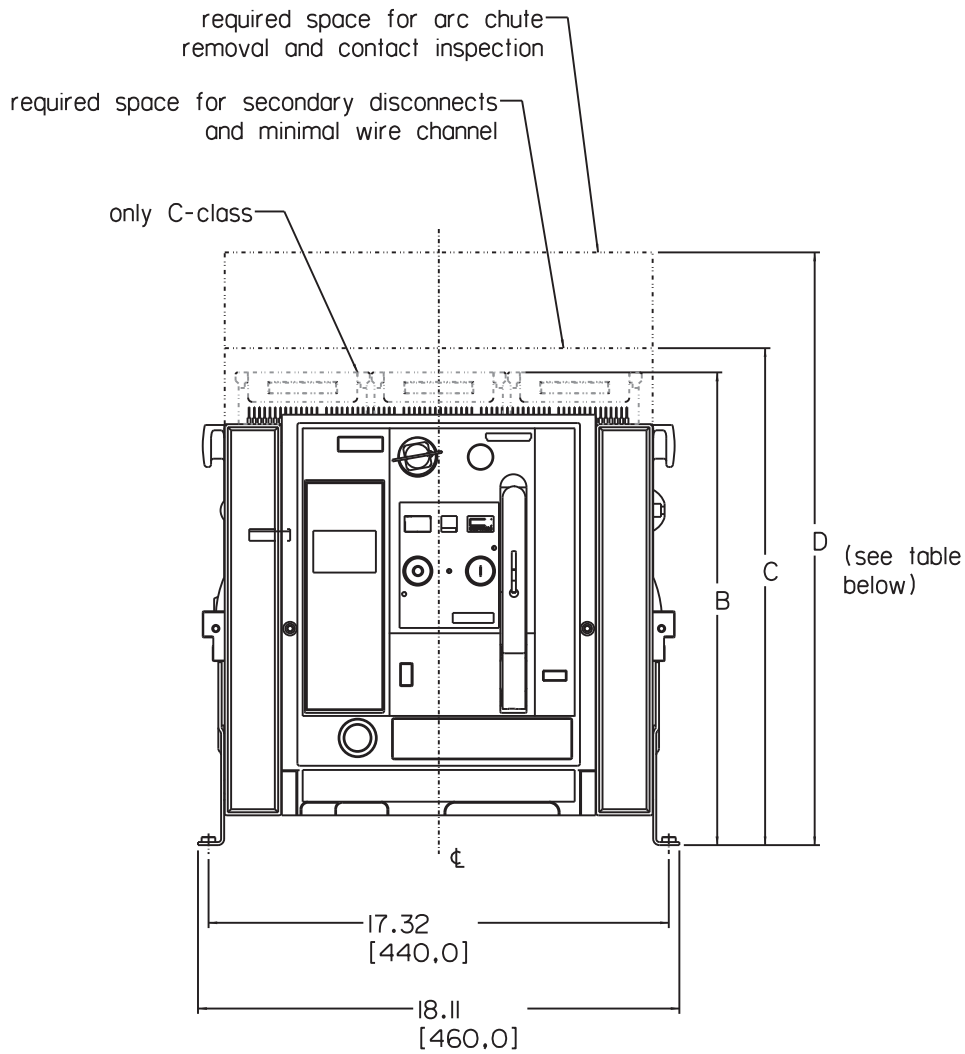

Interrupting class	Dimension B	Dimension C	Dimension D
S/L	15.85 [402.5]	18.70 [475.0]	22.30 [566.5]
C	17.80 [452.10]	18.70 [475.0]	25.20 [640.0]

Low Voltage Circuit Breaker

UL489 Fixed-mount Breaker

Dimensions

Frame Size 2

Optional Vertical Connectors

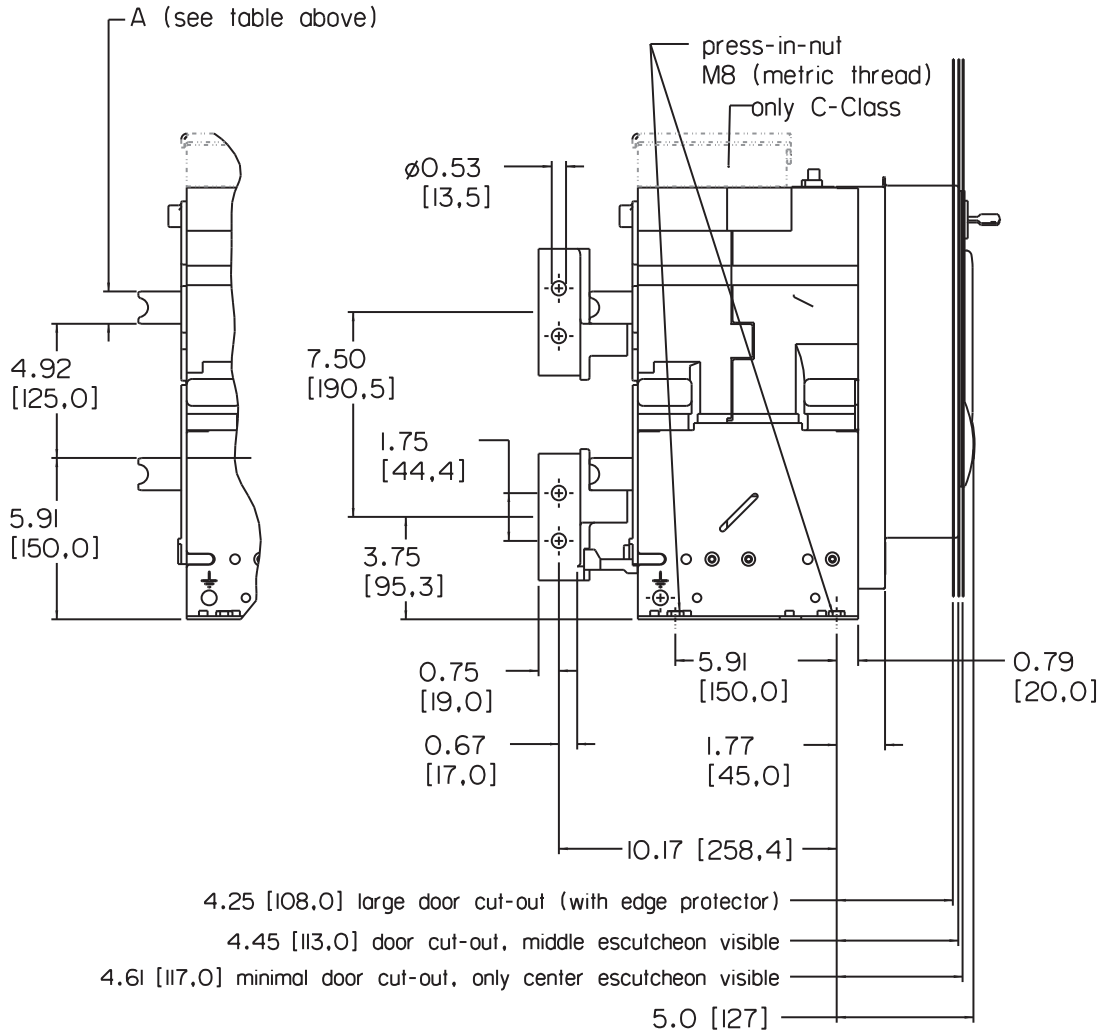

Interrupting Class	Rated Current	Dimension A
S/L	max. 1600 A	0.39 [10]
S/L	max. 2000 A	0.59 [15]
S/L	max. 3000 A	1.18 [30]
C	1600 - 3000 A	1.18 [30]

Low Voltage Circuit Breaker

UL489 Fixed-mount Breaker

Frame Size 2

Optional Vertical Connectors

Dimensions

Top view

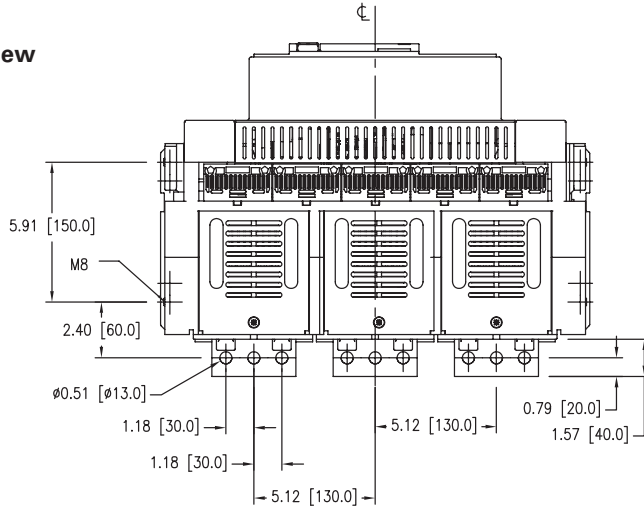

Rated Current	Dimension A
max. 1600 A	0.39 [10]
max. 2000 A	0.59 [15]
max. 3000 A	1.18 [30]
C-class always	1.18 [30]

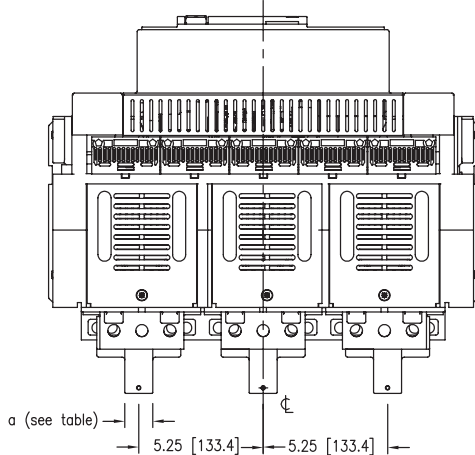

Rear view

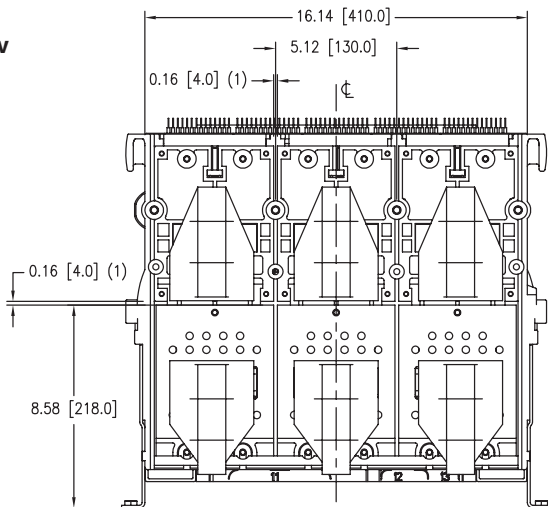

(1) = Slots 0.2 [5] for insulation barriers

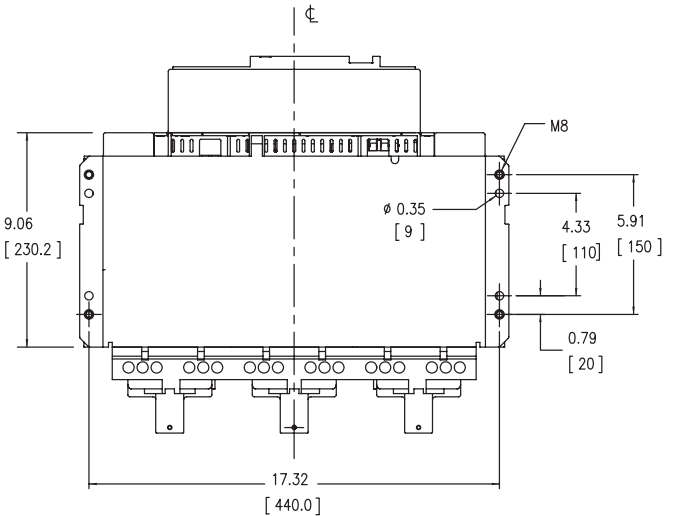

Low Voltage Circuit Breaker

UL489 Fixed-mount Breaker

Frame Size 2
Front Connectors

Dimensions

LH side view

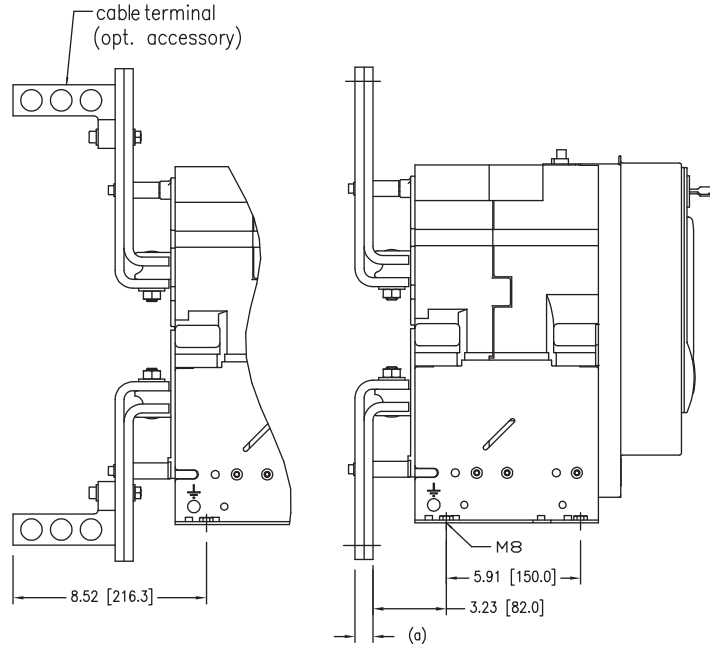

Rated Current	Dimension A
max. 1600 A	0.39 [10]
max. 2000 A	0.79 [20]
max. 2500 A	0.79 [20]

Front view

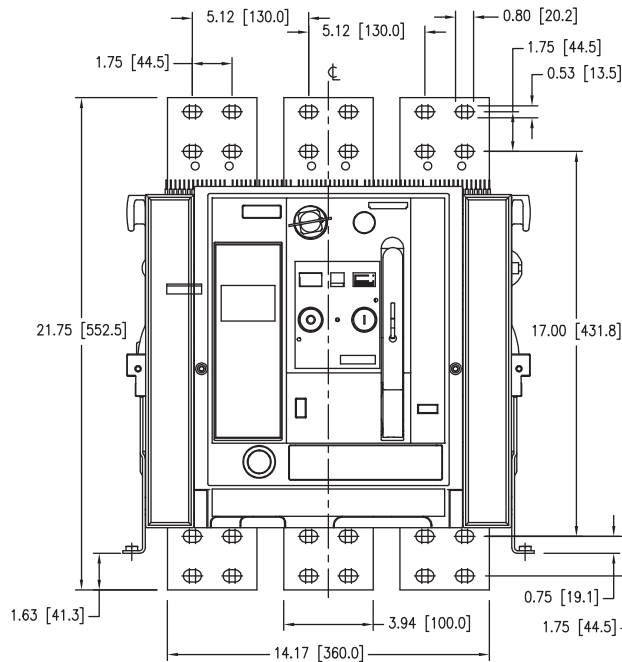

Low Voltage Circuit Breaker

UL489 Fixed-mount Breaker

Dimensions

Frame Size 2

3000A Front Connectors

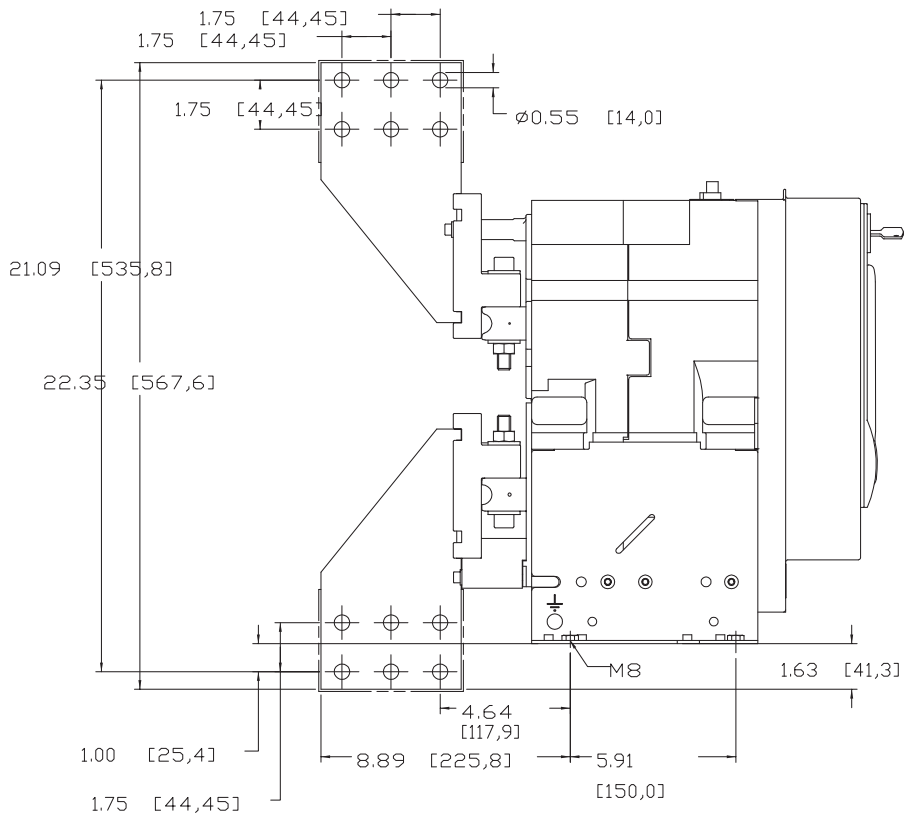
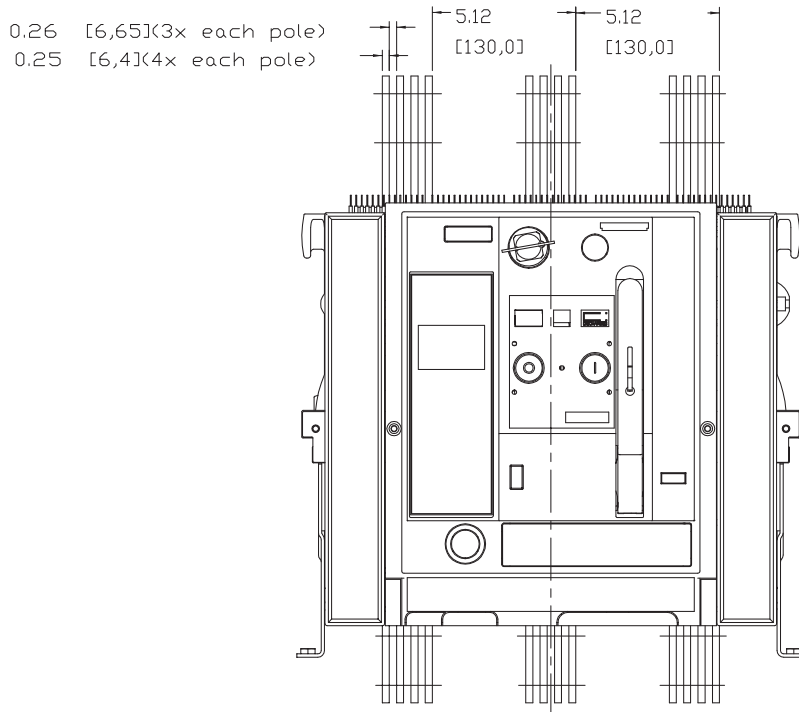

Low Voltage Circuit Breaker

UL489 Fixed-mount Breaker

Frame Size 3

Dimensions

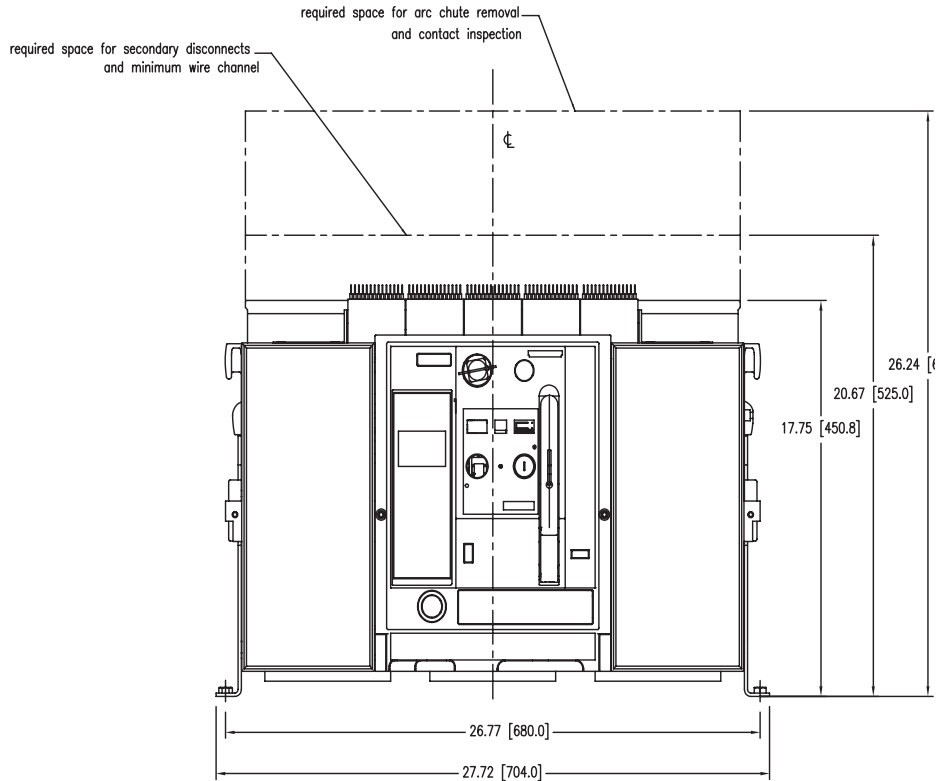

LH side view

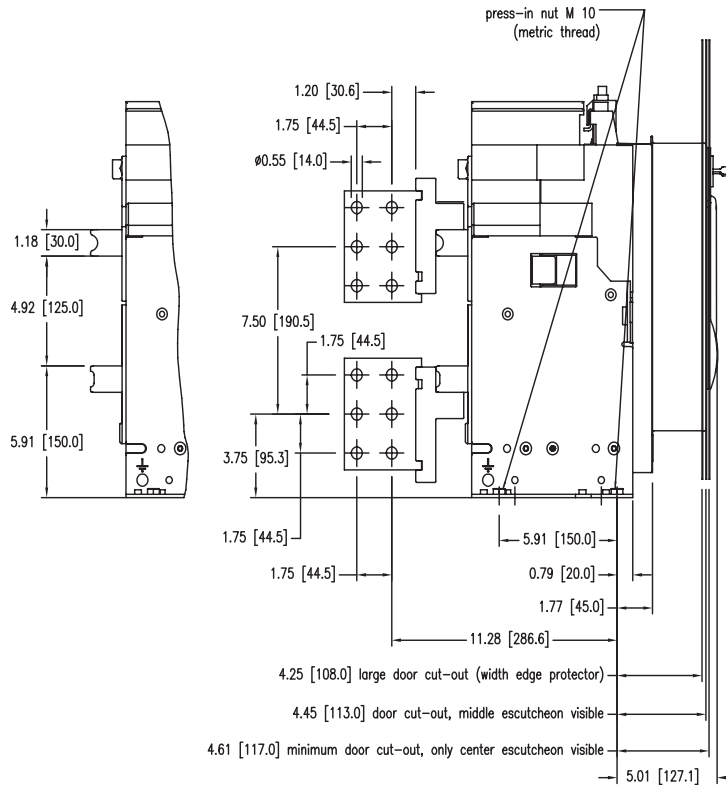

Low Voltage Circuit Breaker

UL489 Fixed-mount Breaker

Dimensions

Frame Size 3

Vertical Connectors and Horizontal Stabs

Top view

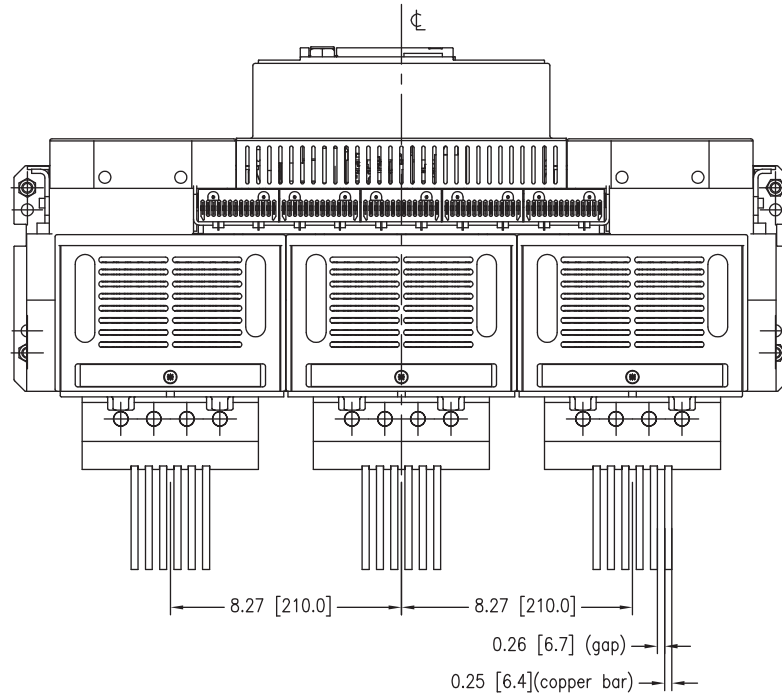

Top view

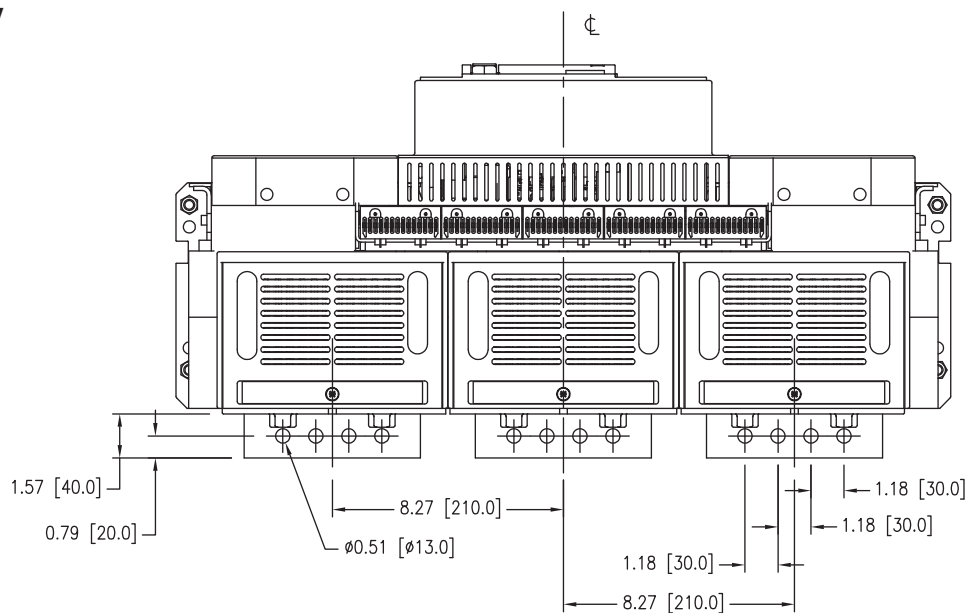

Low Voltage Circuit Breaker

UL489 Fixed-mount Breaker

Frame Size 3

Dimensions

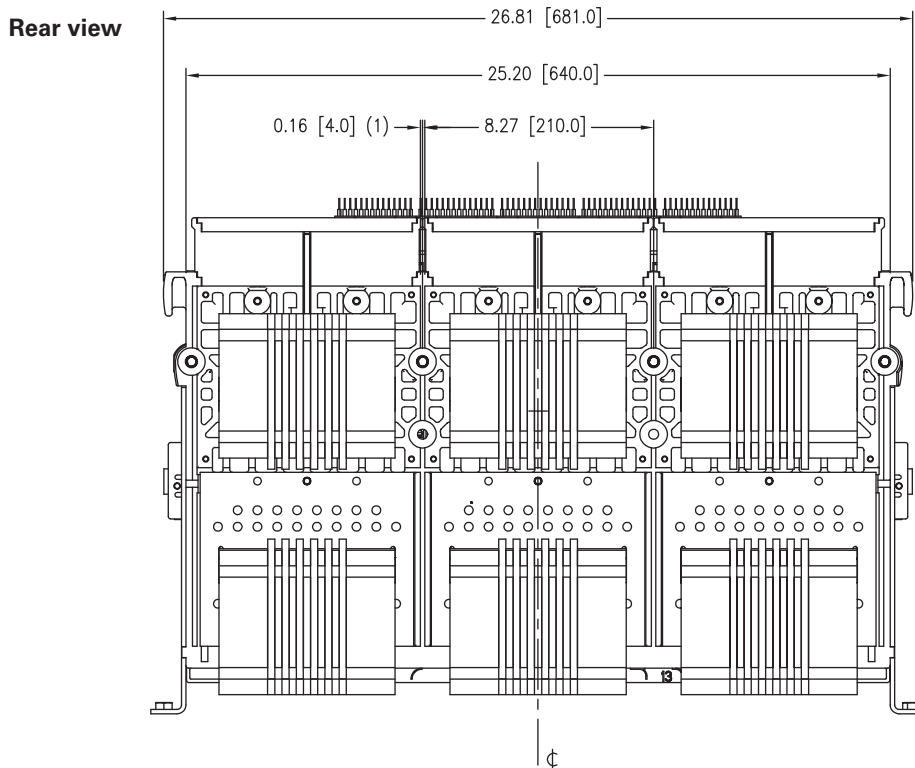
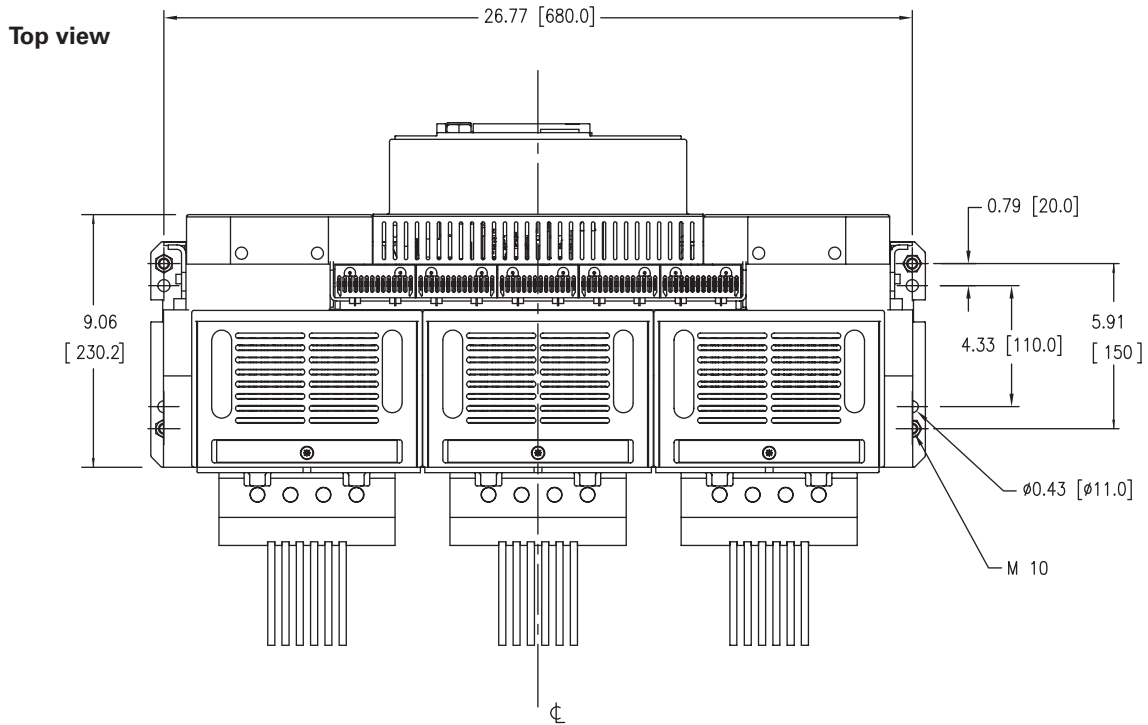

(1) = Slots 0.2 [5] for insulation barriers

Low Voltage Circuit Breaker

UL489 Fixed-mount Breaker

Dimensions

Frame Size 3

5000A Vertical Connectors

LH side view

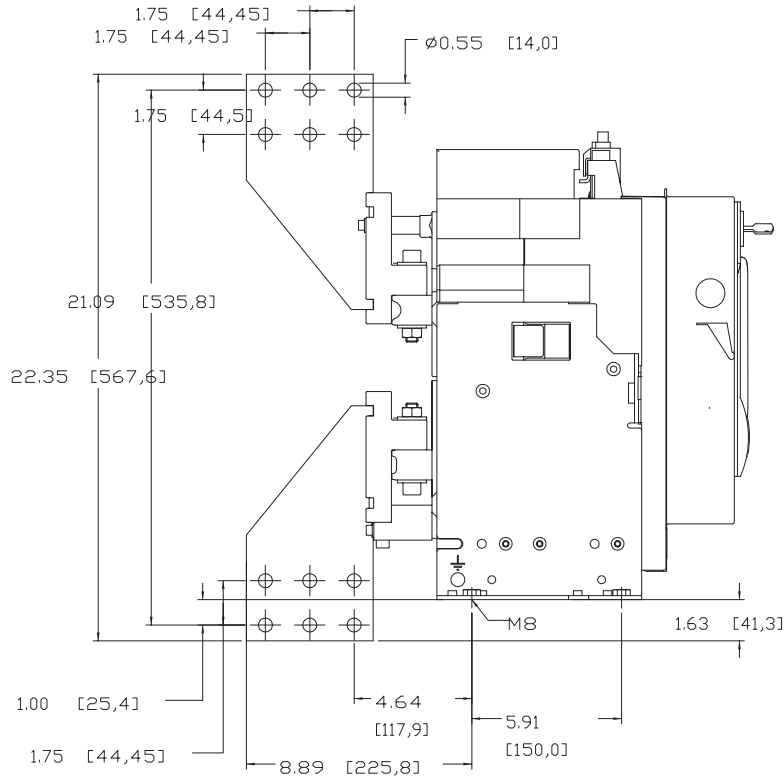

Front view

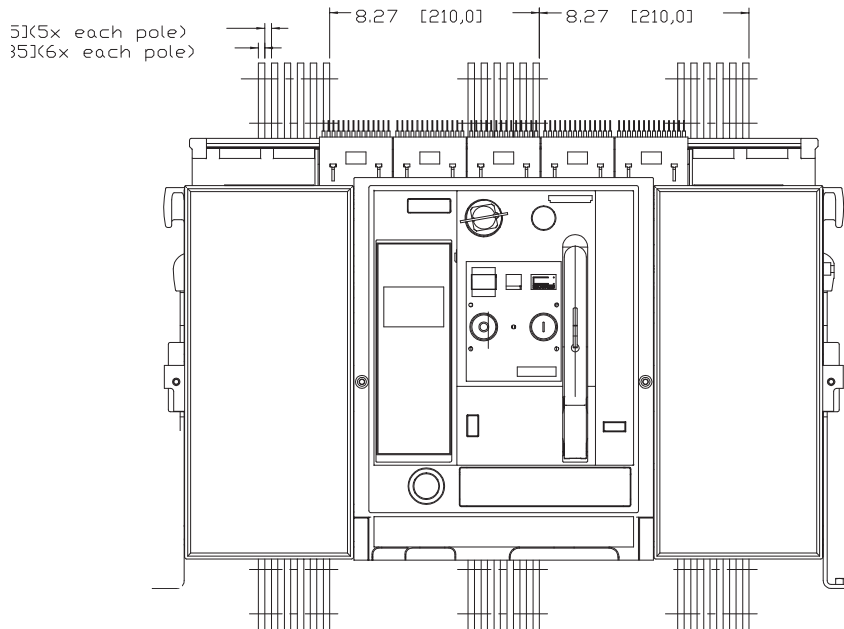

Low Voltage Circuit Breaker

UL489 Fixed-mount Breaker

Dimensions

Frame Size 2 and 3

Door Cut-outs

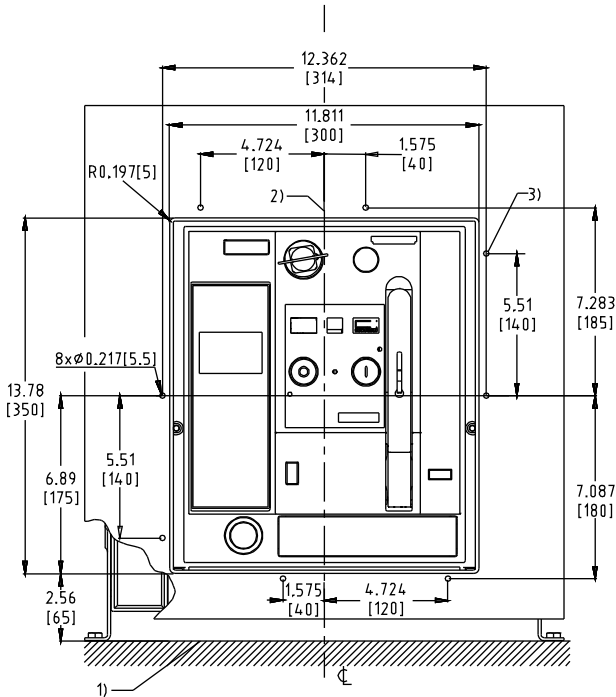

Door cut-out and mounting holes for Door Sealing Frame

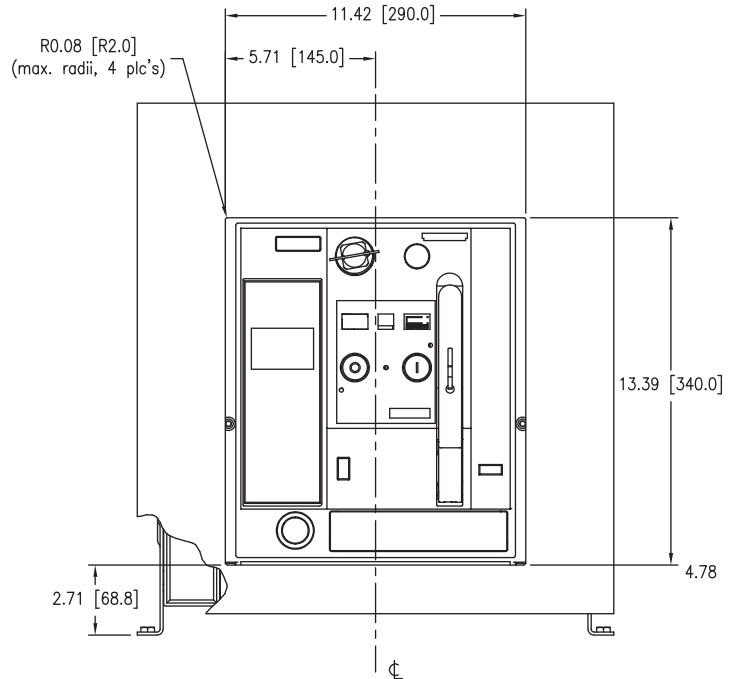

Door cut-out (after mounting Door Sealing Frame)

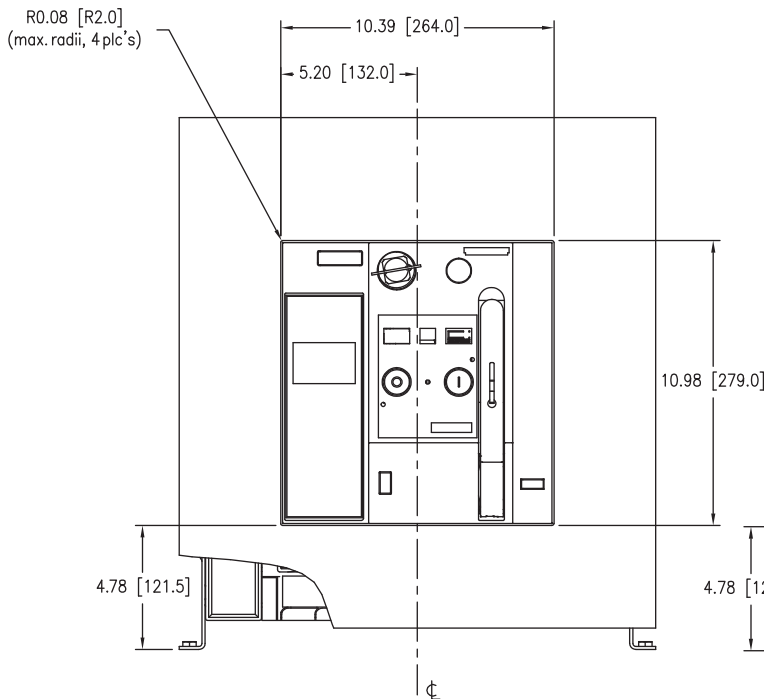

Door cut-out (Middle escutcheon visible)

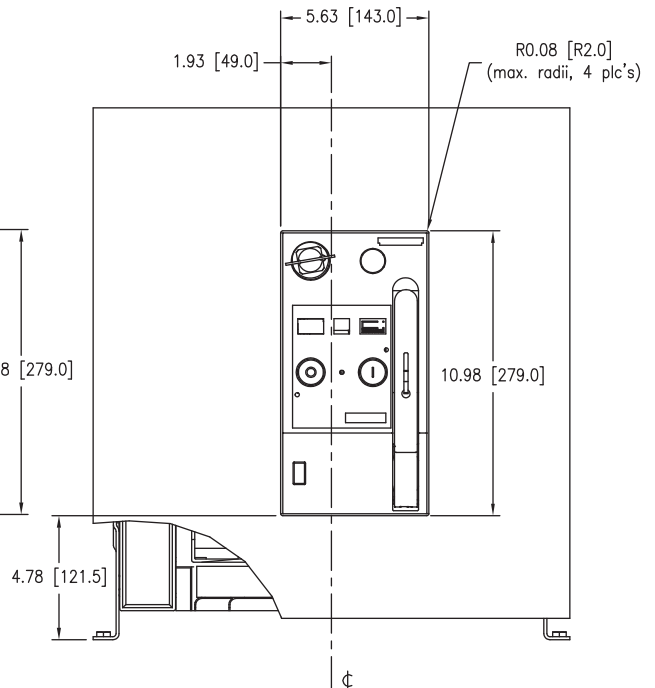

Minimal door cut-out (Only center escutcheon visible)

- 1) Breaker mounting surface.
- 2) Center of breaker front panel.
- 3) Drill eight holes for mounting door sealing frame.

6

W1 POWER
CIRCUIT BREAKERS

Low Voltage Circuit Breaker

UL489 Draw-out Breaker

Dimensions

Frame Size 1

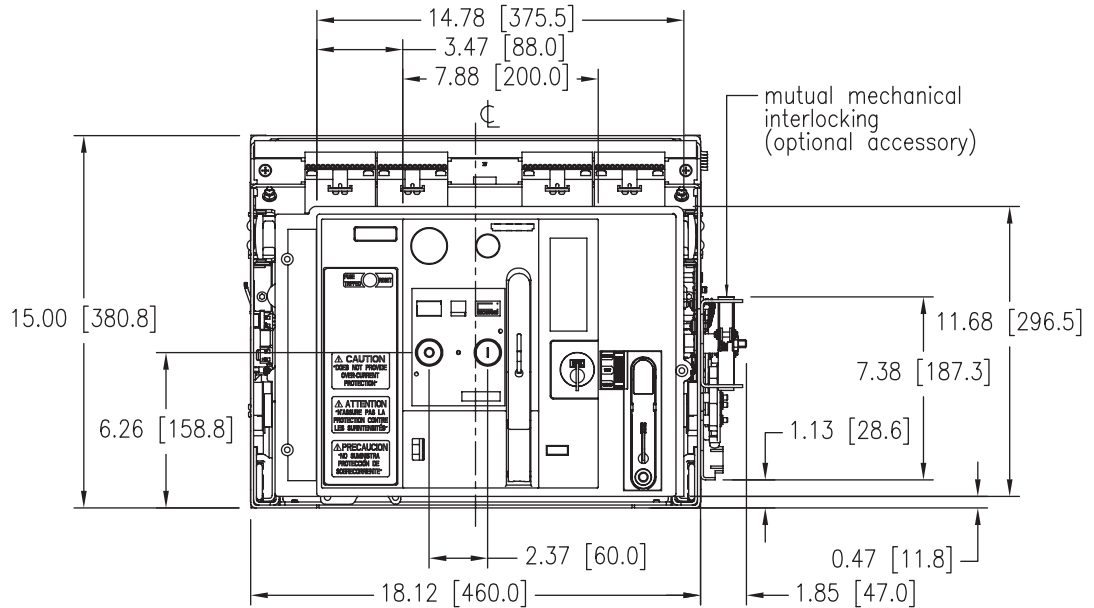
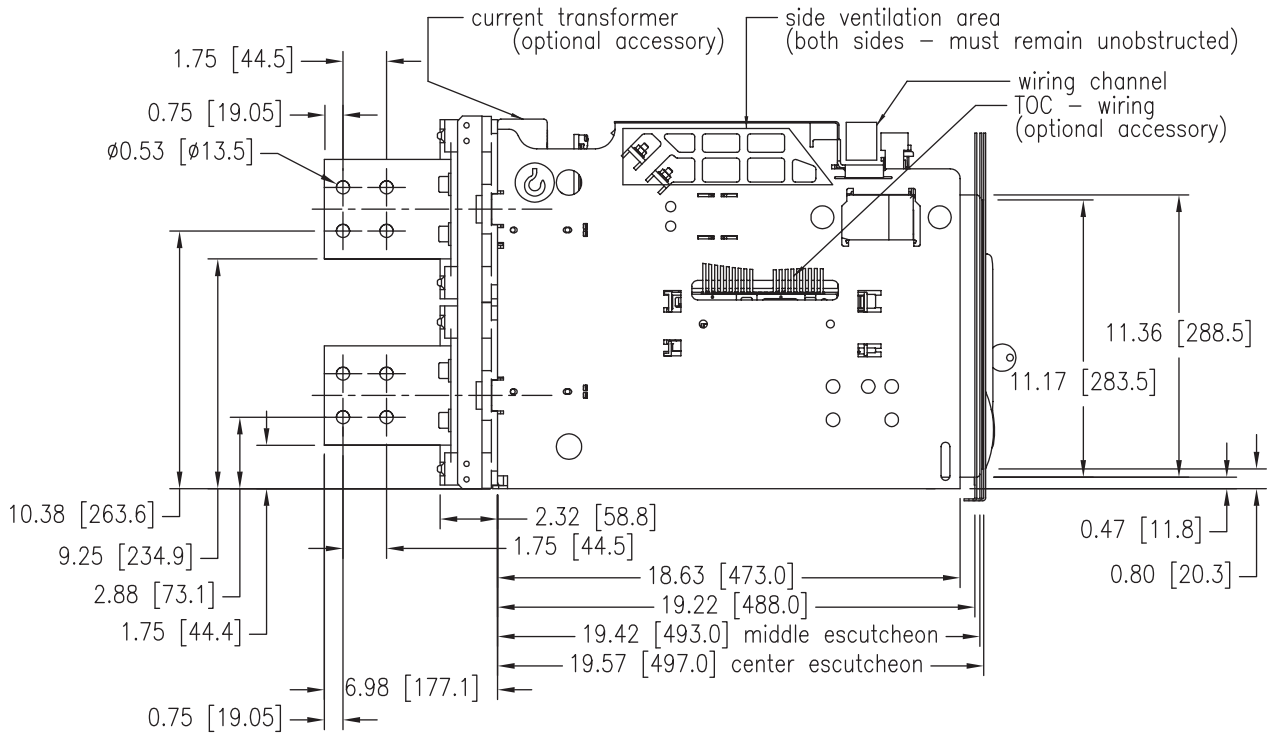

Low Voltage Circuit Breaker

UL489 Draw-out Breaker

Frame Size 1

Vertical Connectors

Dimensions

Rear view

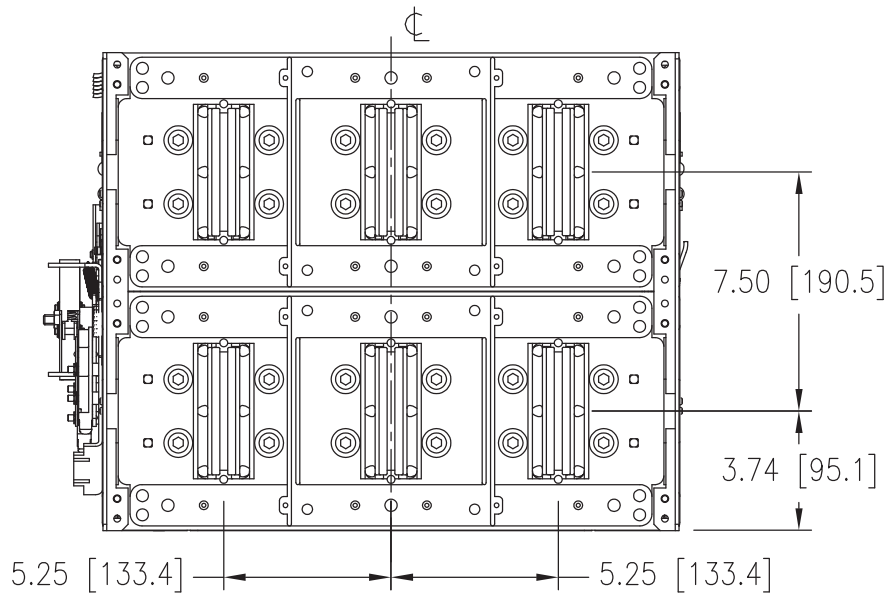

Top view

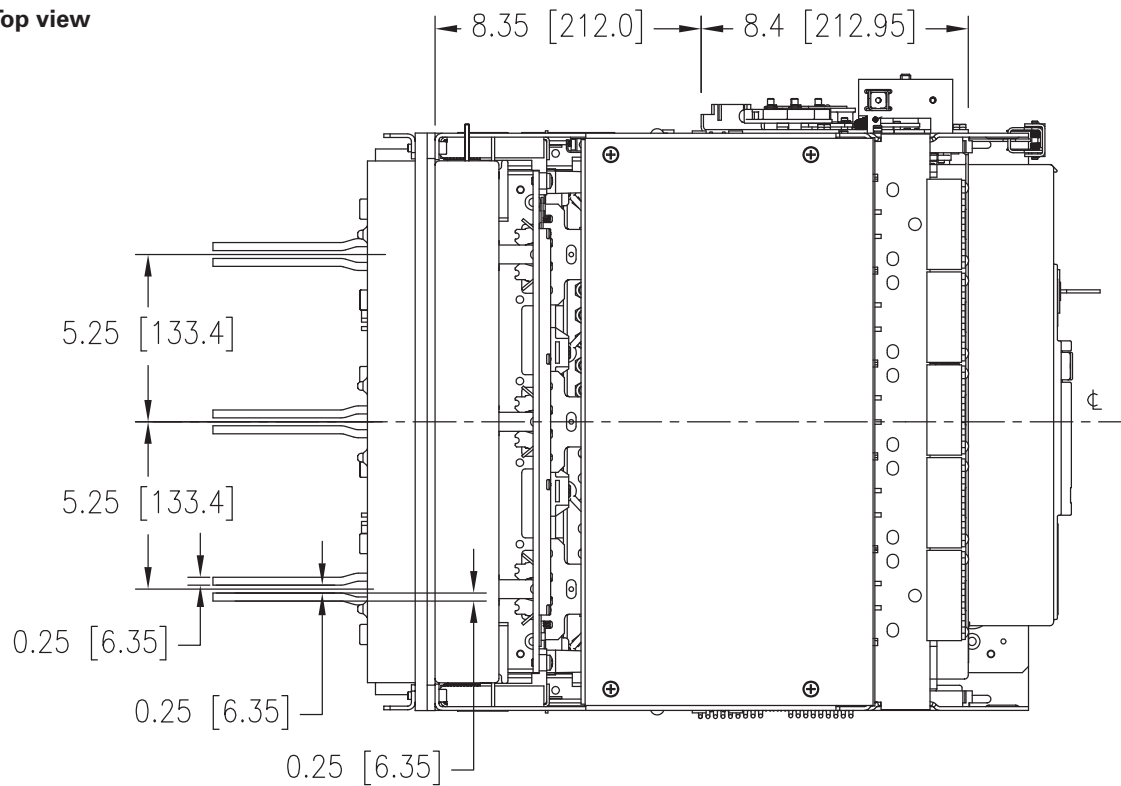

Low Voltage Circuit Breaker

UL489 Draw-out Breaker

Dimensions

Frame Size 1

Bottom view

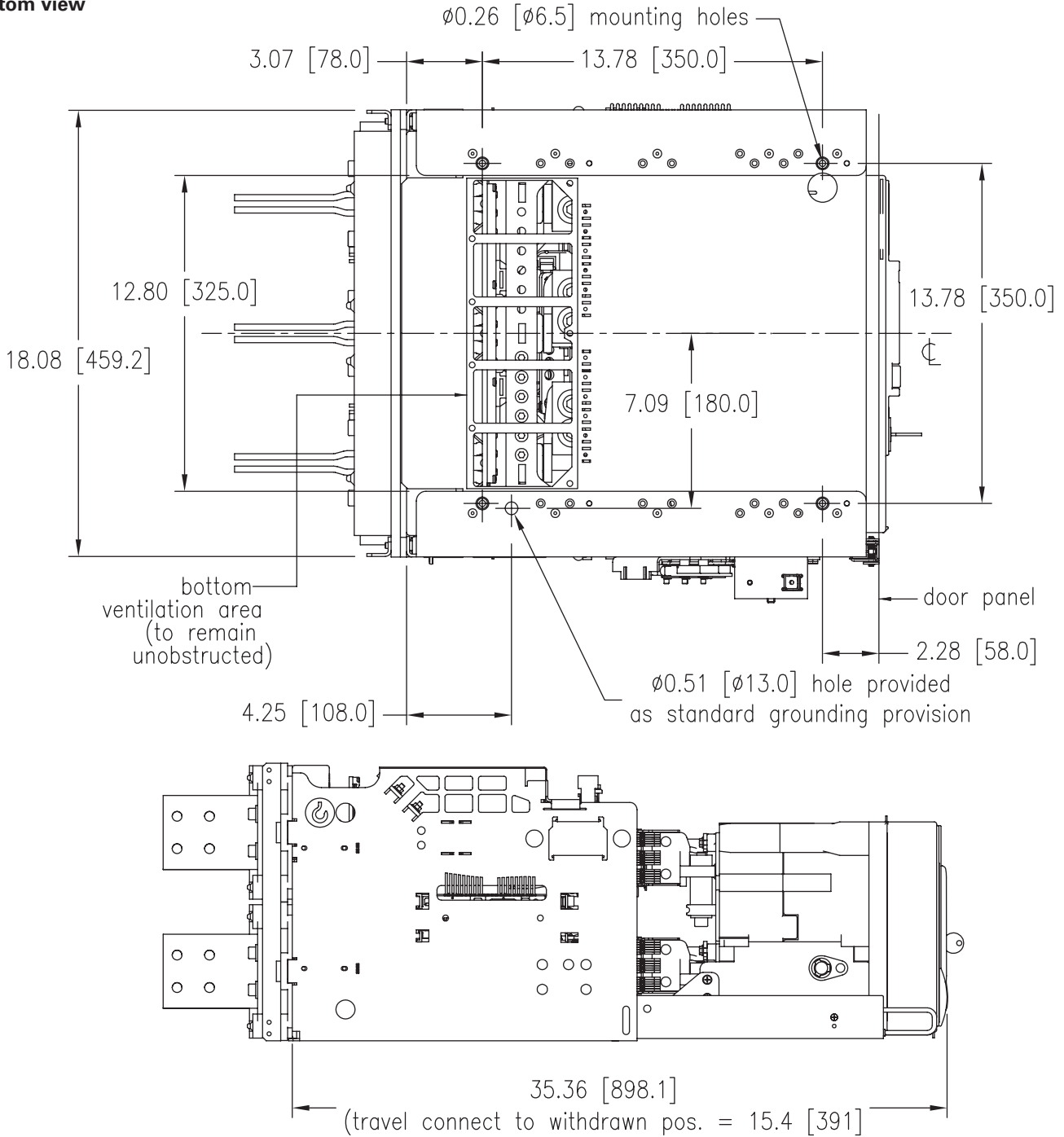

Low Voltage Circuit Breaker

UL489 Draw-out Breaker

Frame Size 1

Charging and Racking

Dimensions

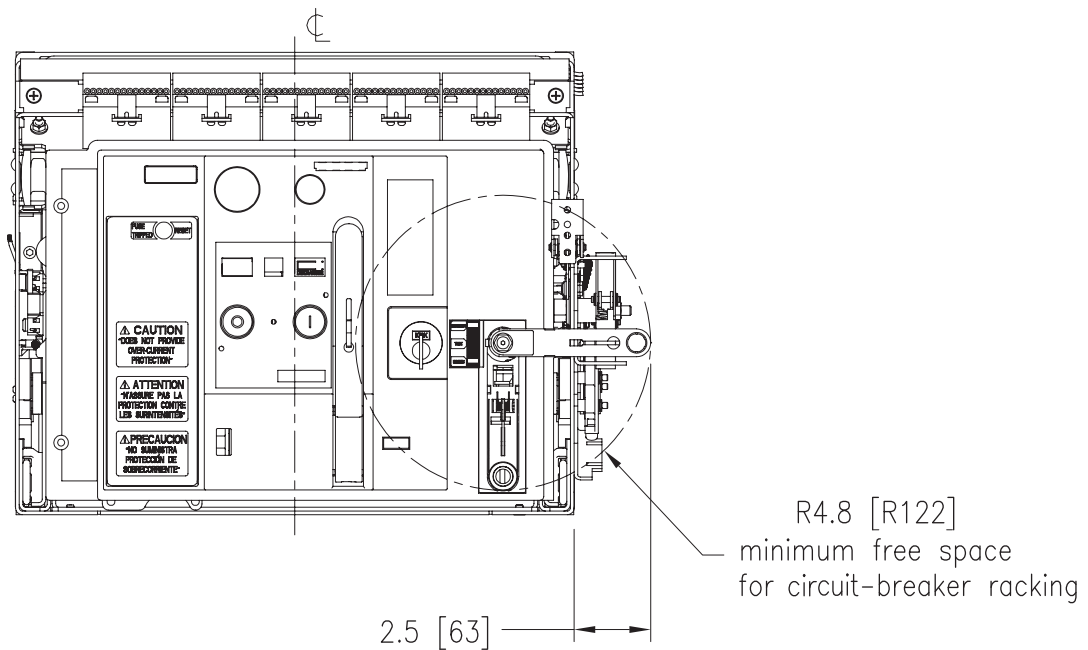
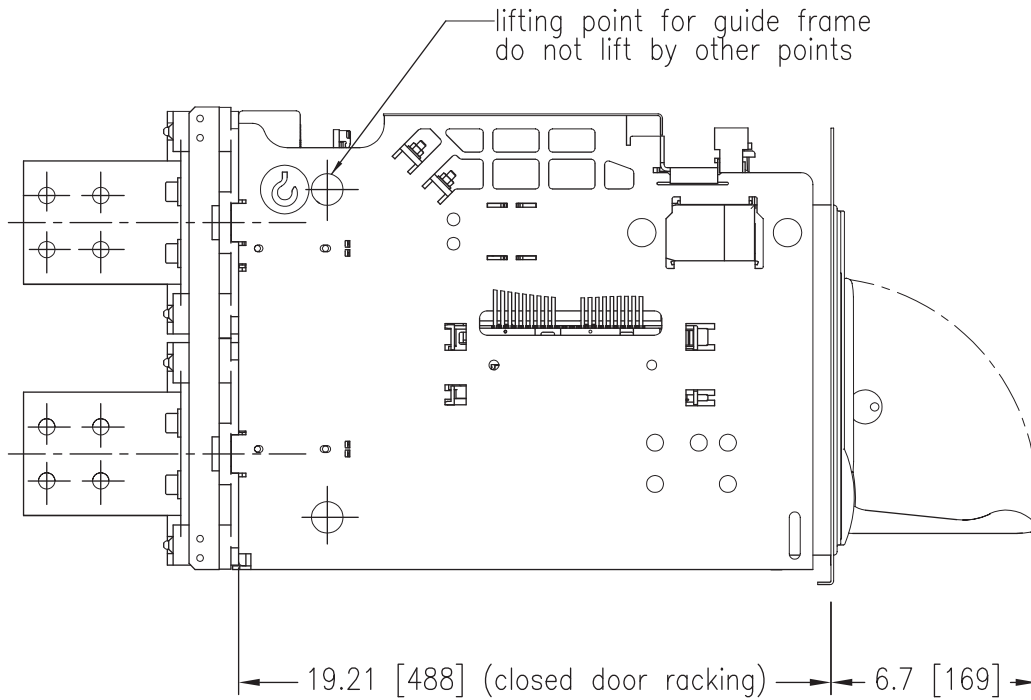

Low Voltage Circuit Breaker

UL489 Draw-out Breaker

Frame Size 1

Plexiglass Cover

Dimensions

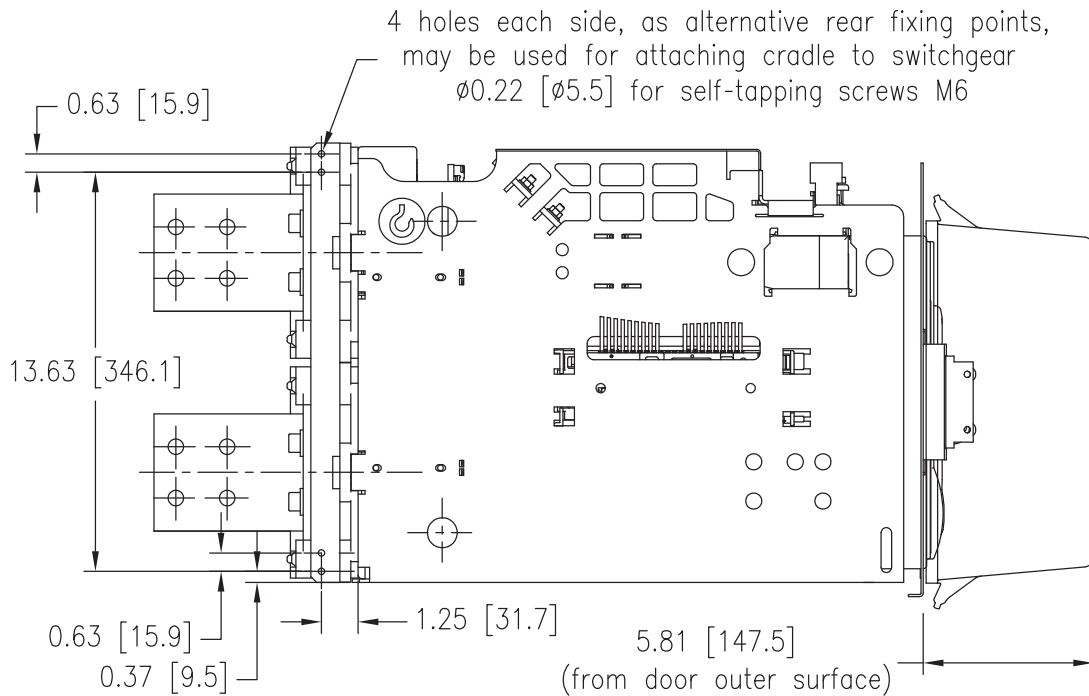
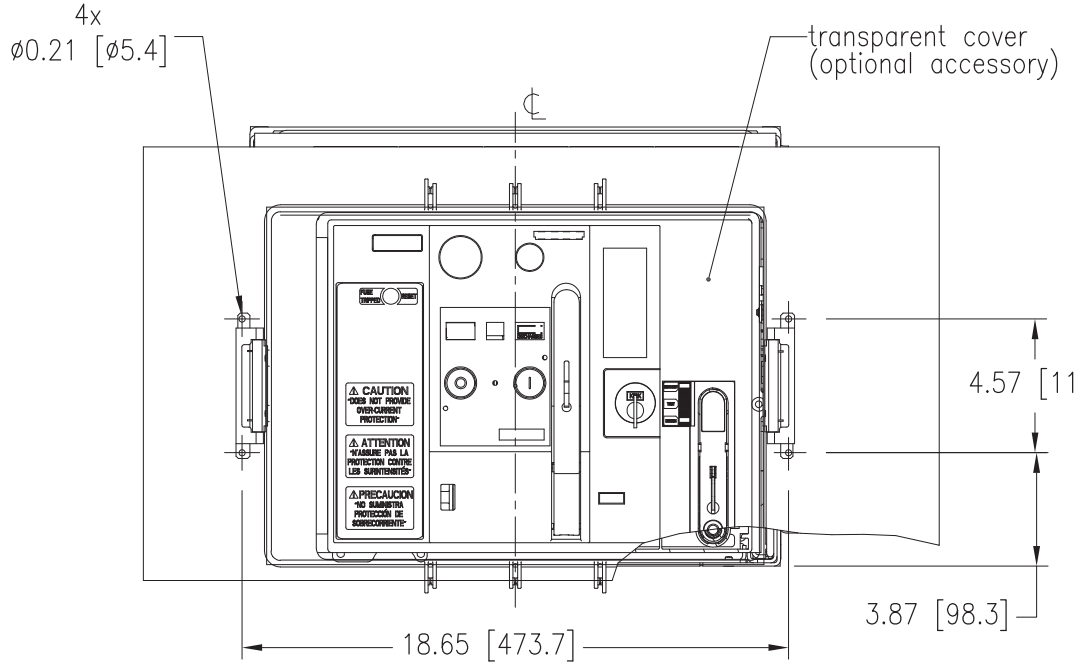

Low Voltage Circuit Breaker

UL489 Draw-out Breaker

Dimensions

Frame Size 1

Door Cut-outs

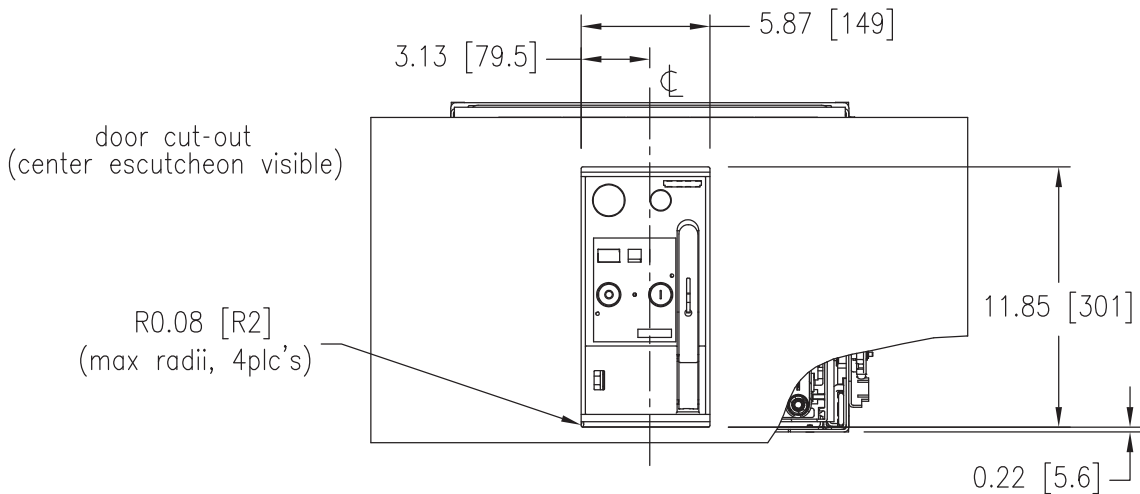
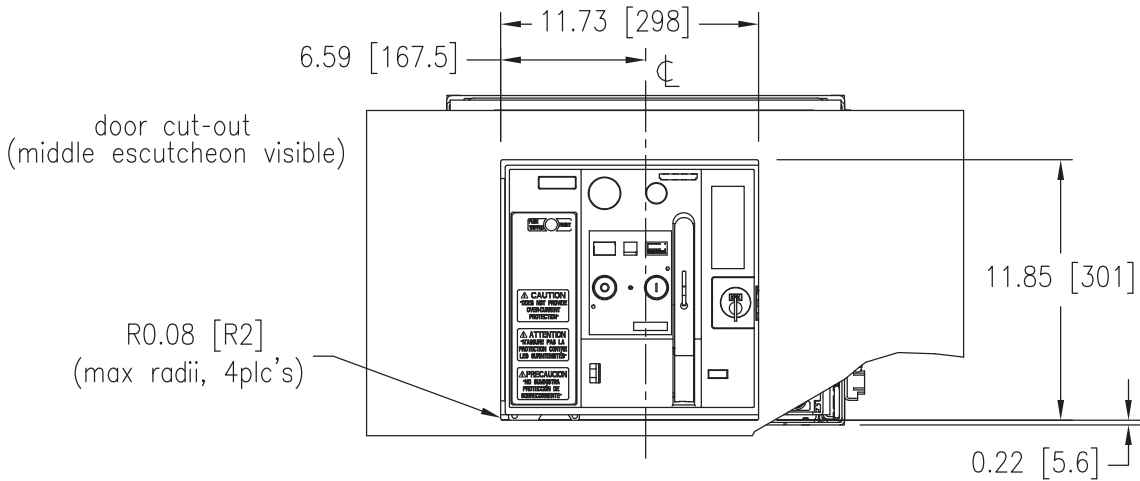
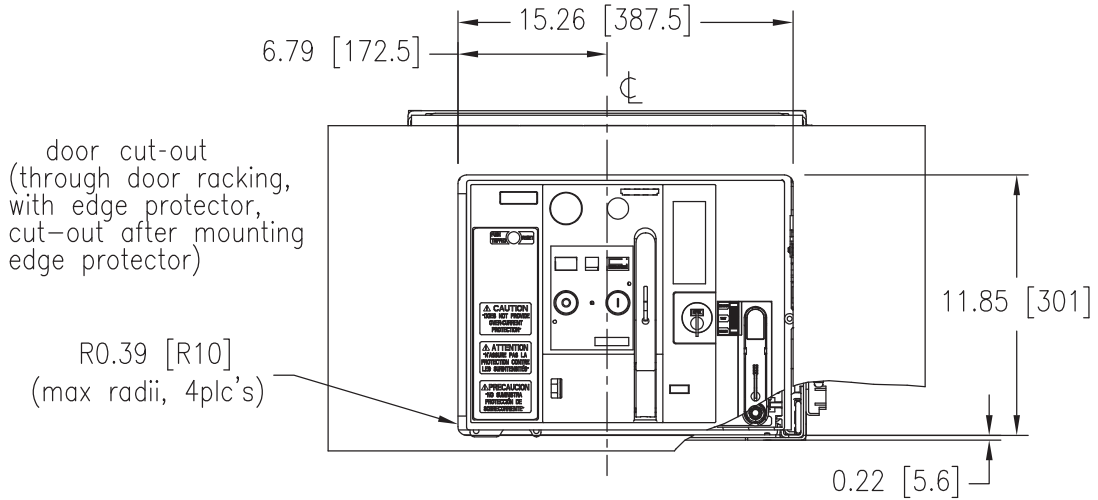

Low Voltage Circuit Breaker

UL489 Draw-out Breaker

Frame Size 2

Dimensions

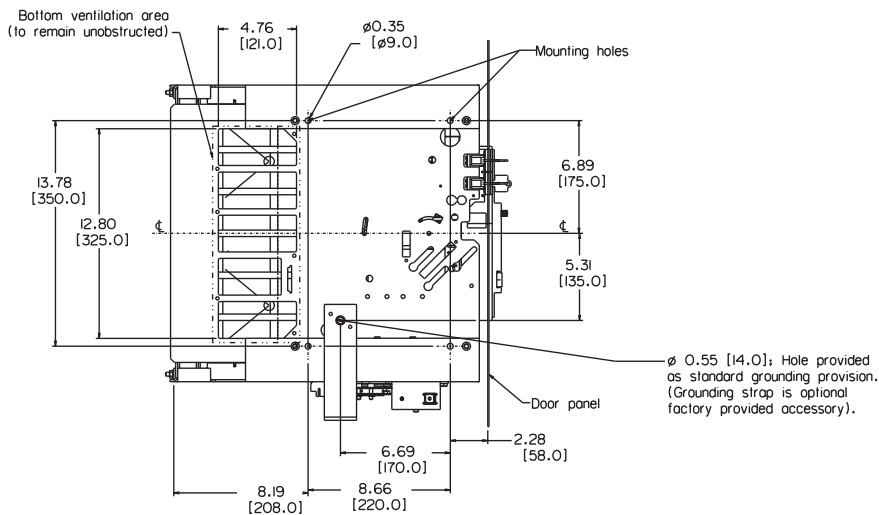
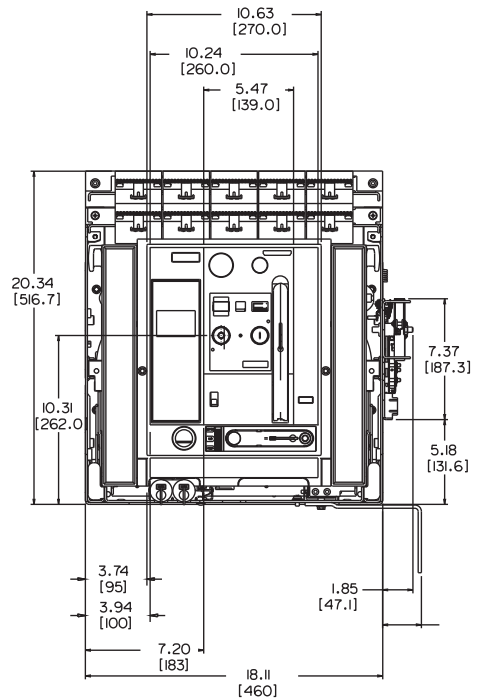
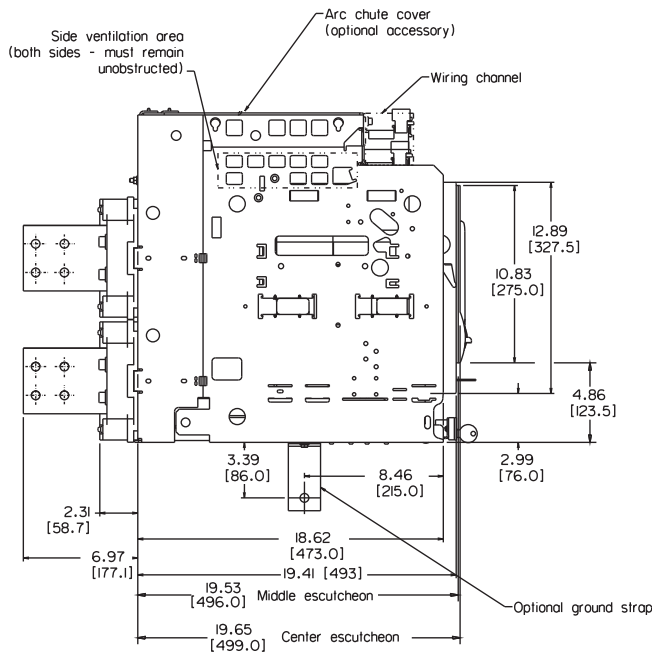
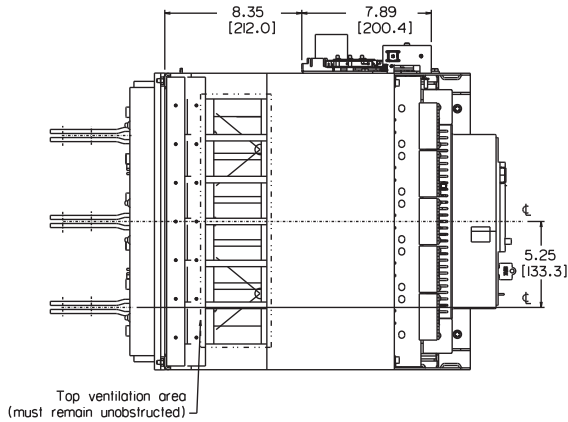

Low Voltage Circuit Breaker

UL489 Draw-out Breaker

Dimensions

Frame Size 2

2500/3000A

2000A

800/1200/1600A

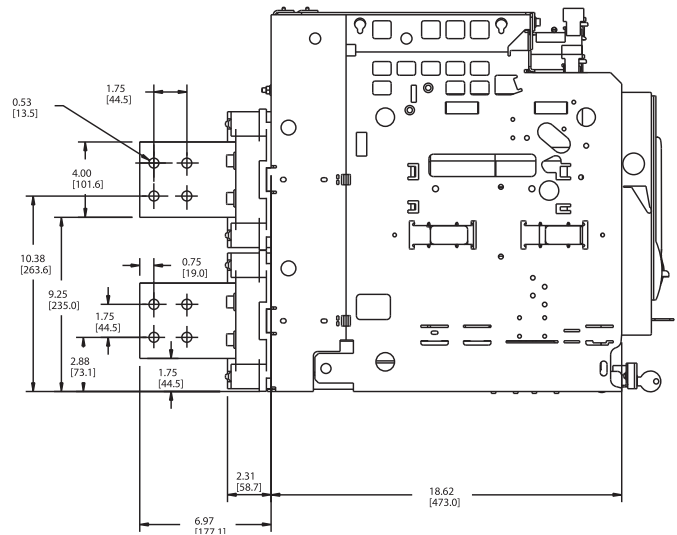
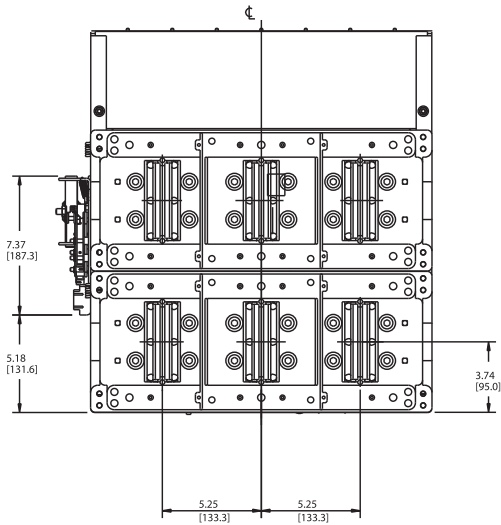
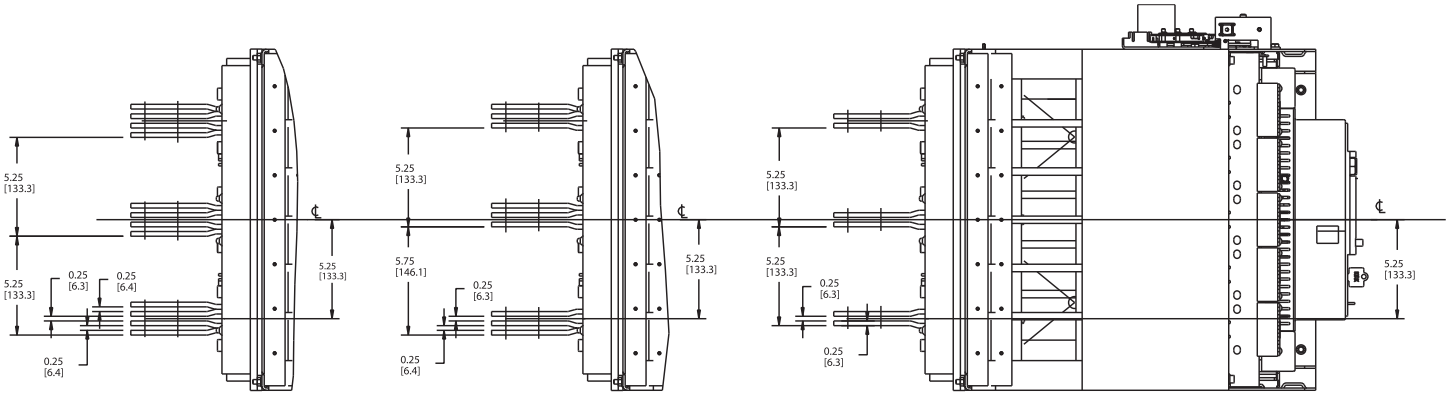

6

W1 POWER
CIRCUIT BREAKERS

Low Voltage Circuit Breaker

UL489 Draw-out Breaker

Dimensions

Frame Size 2

Vertical Connectors and Optional Horizontal Connectors

Horizontal Main Bus Connectors

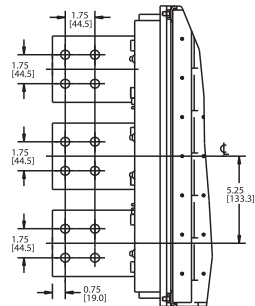

Vertical Main Bus Connectors

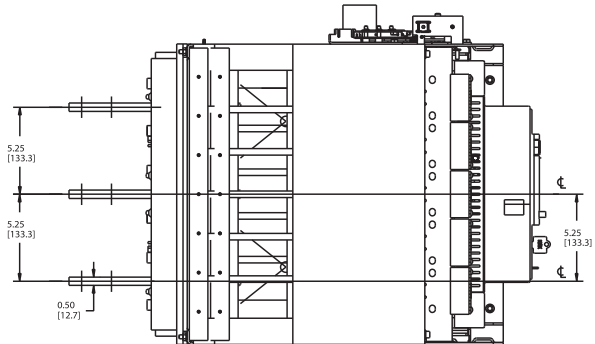

Horizontal Main Bus Connectors

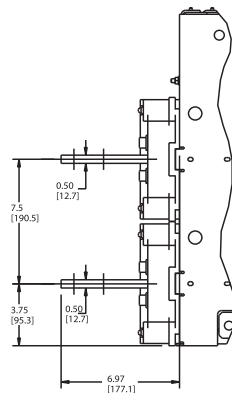
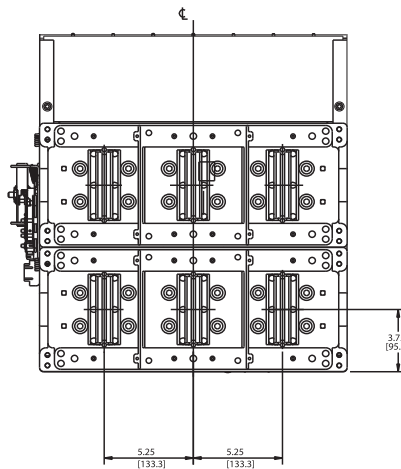

Vertical Main Bus Connectors

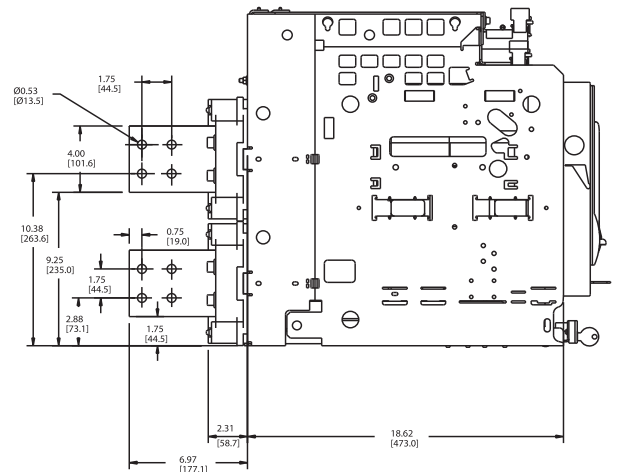

NOTE:

Rotatable main bus connectors are only available under the following conditions:

- (1) Only acceptable for FS II 800A-2000A Frame Sizes
- (2) Only acceptable for short circuit ratings of 85KAIC or less

Low Voltage Circuit Breaker

UL489 Draw-out Breaker

Frame Size 2

Charging, Racking and Draw-out

Dimensions

Lifting Point (Cradle)
Do not lift by other
means.

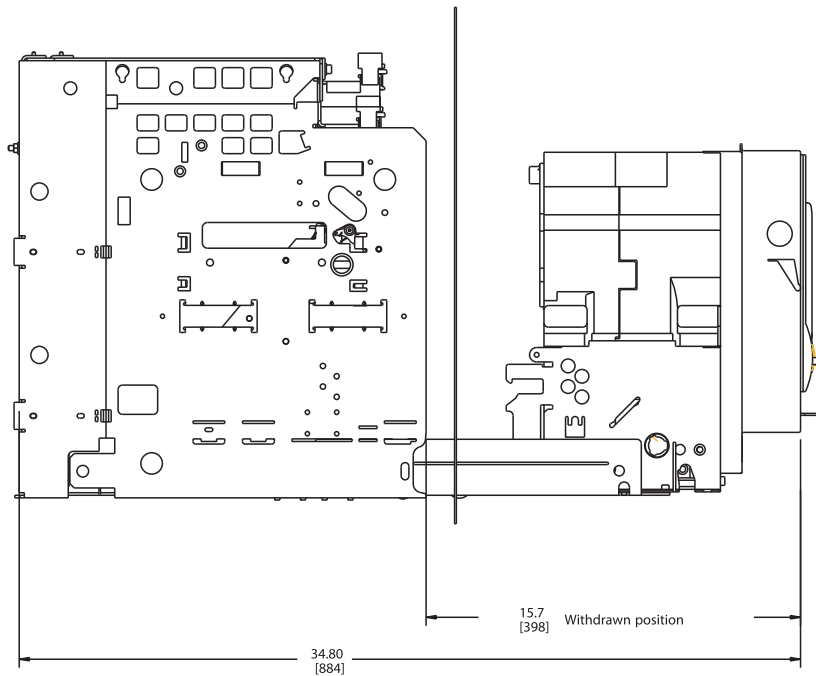
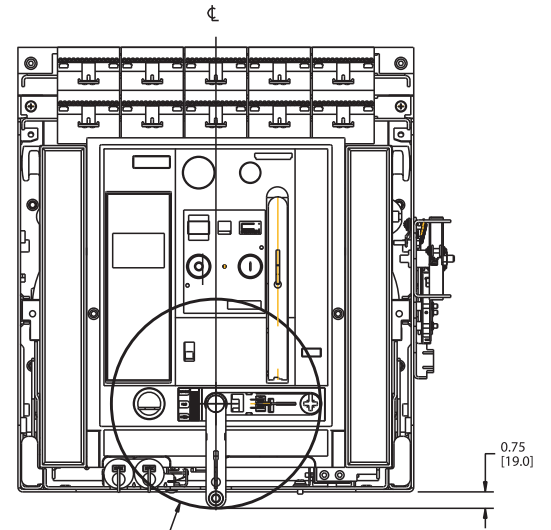
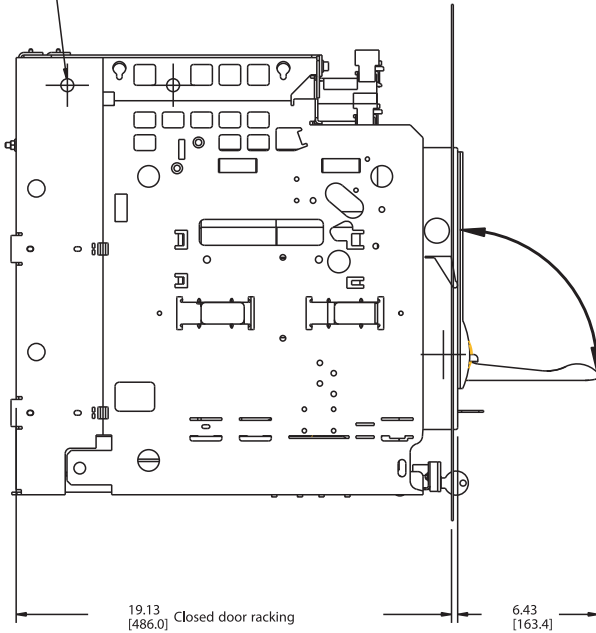

6

W1 POWER
CIRCUIT BREAKERS

Low Voltage Circuit Breaker

UL489 Draw-out Breaker

Frame Size 3

Dimensions

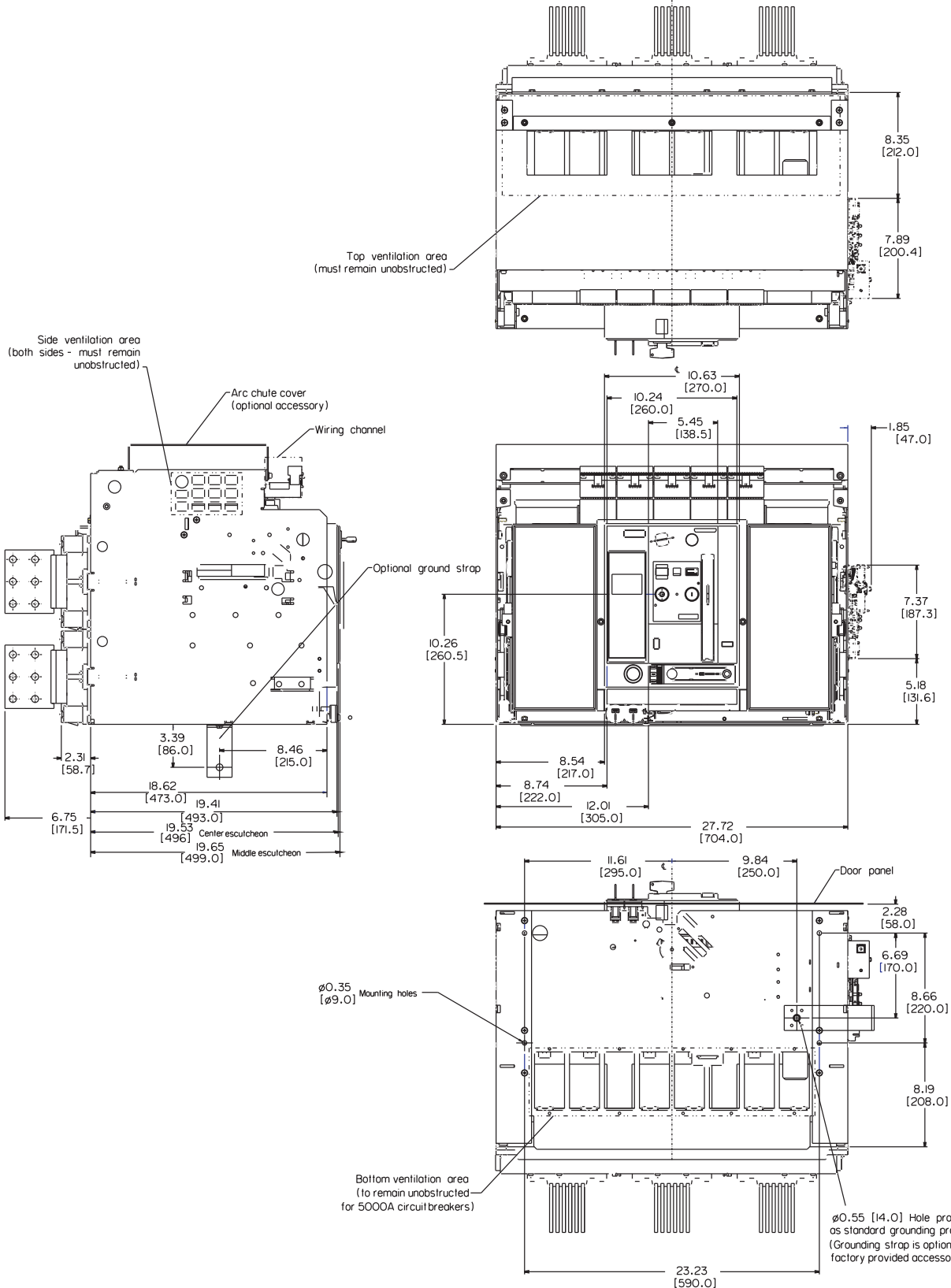

Low Voltage Circuit Breaker

UL489 Draw-out Breaker

Frame Size 3

Vertical Connectors

Dimensions

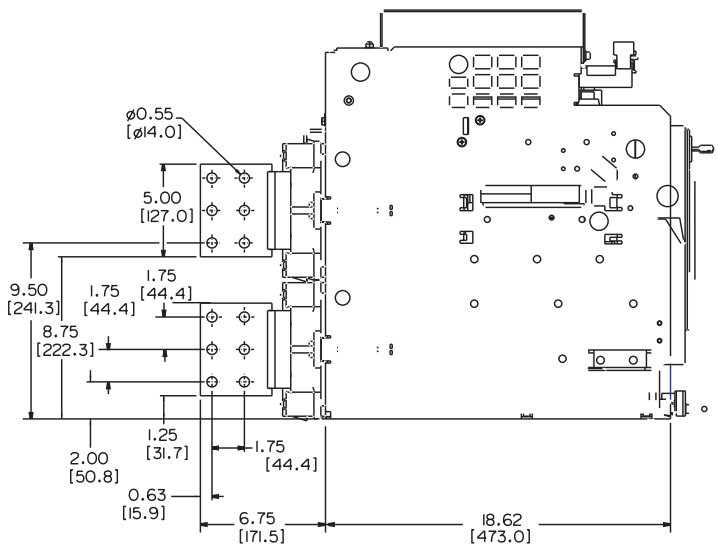
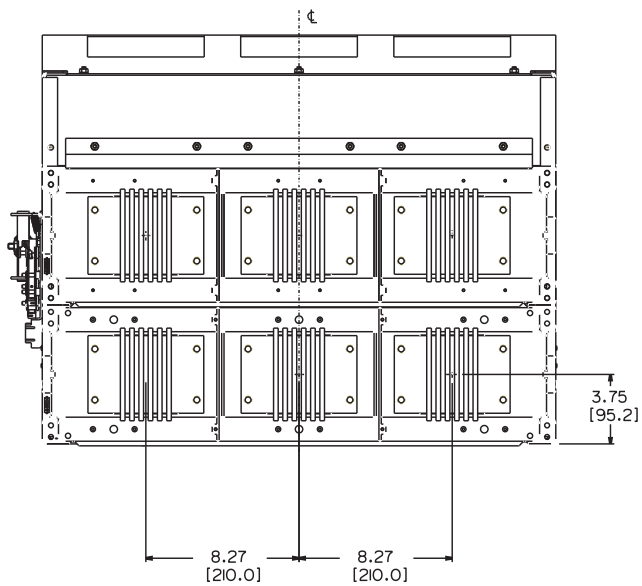
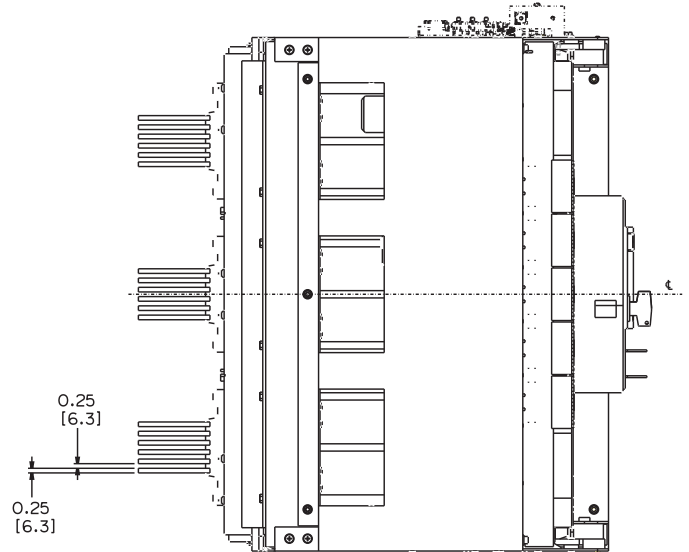

Low Voltage Circuit Breaker

UL489 Draw-out Breaker

Dimensions

Frame Size 3

Charging, Racking and Draw-out

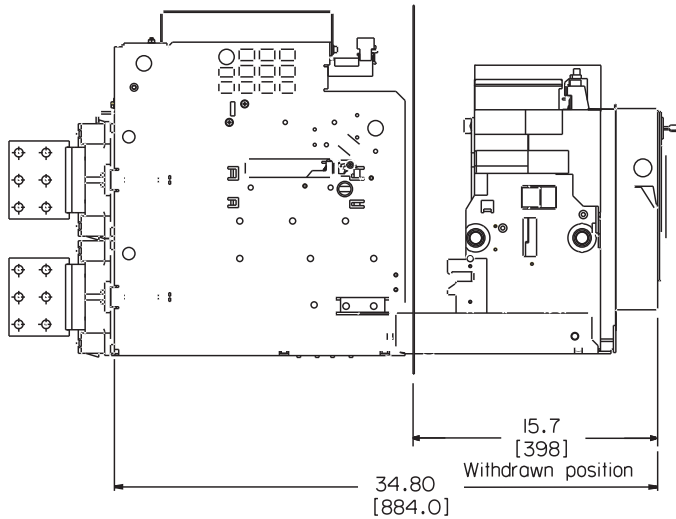
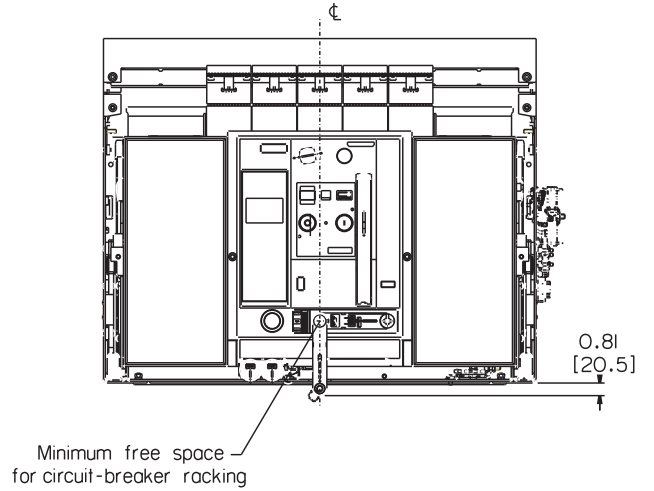
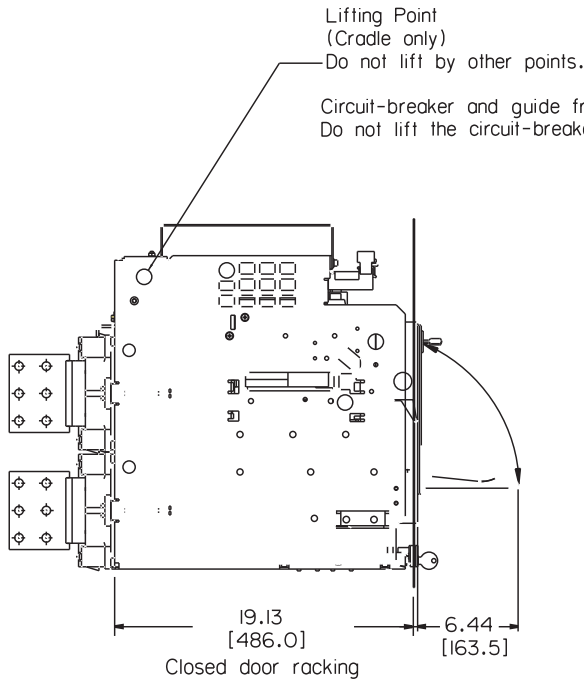

Low Voltage Circuit Breaker

UL489 Draw-out Breaker

Frame Size 2 and 3

Door Cut-outs

Dimensions

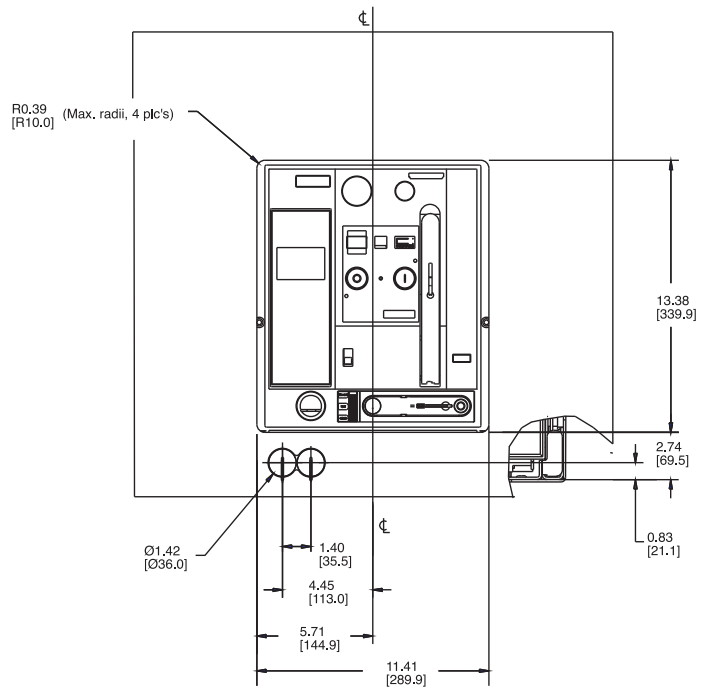
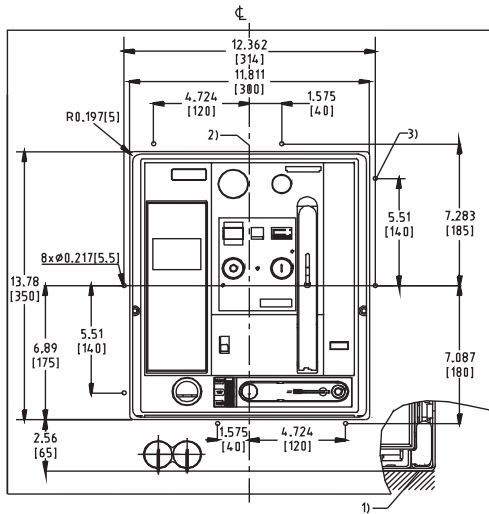

Door cut-out and mounting holes for Door Sealing Frame

Door cut-out (after mounting Door Sealing Frame)

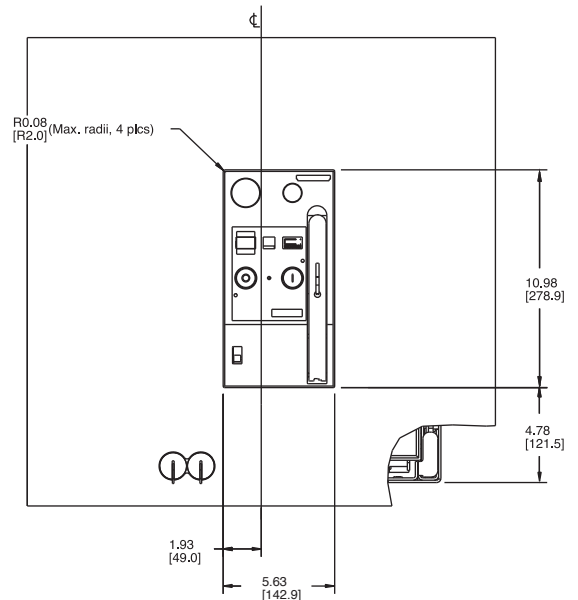
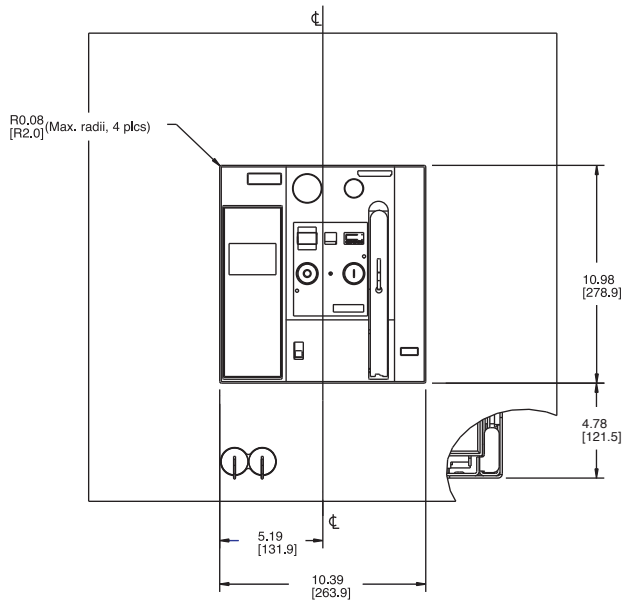

Door cut-out (Middle escutcheon visible)

Minimal door cut-out (Only center escutcheon visible)

- 1) Mounting surface of the circuit breaker or cradle.
- 2) Center of breaker front panel.
- 3) Drill eight holes for mounting door sealing frame.

Low Voltage Circuit Breaker

UL489 Door Sealing Frame

Frame Size 2 and 3
Door Cut-outs

Dimensions

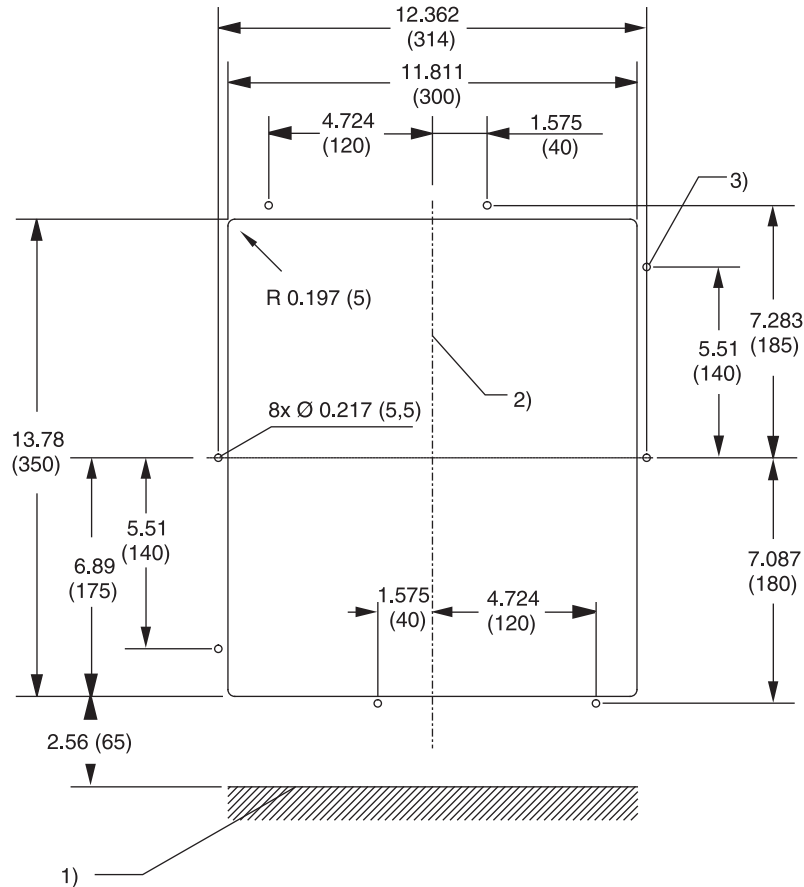

6

W1 POWER
CIRCUIT BREAKERS

- 1) Mounting surface of the circuit-breaker or cradle.
- 2) Center of breaker front panel.
- 3) Drill eight holes for mounting door sealing frame.

Low Voltage Circuit Breaker

UL 1066 Draw-out Non-fused Breaker

Frame Size 2

Dimensions

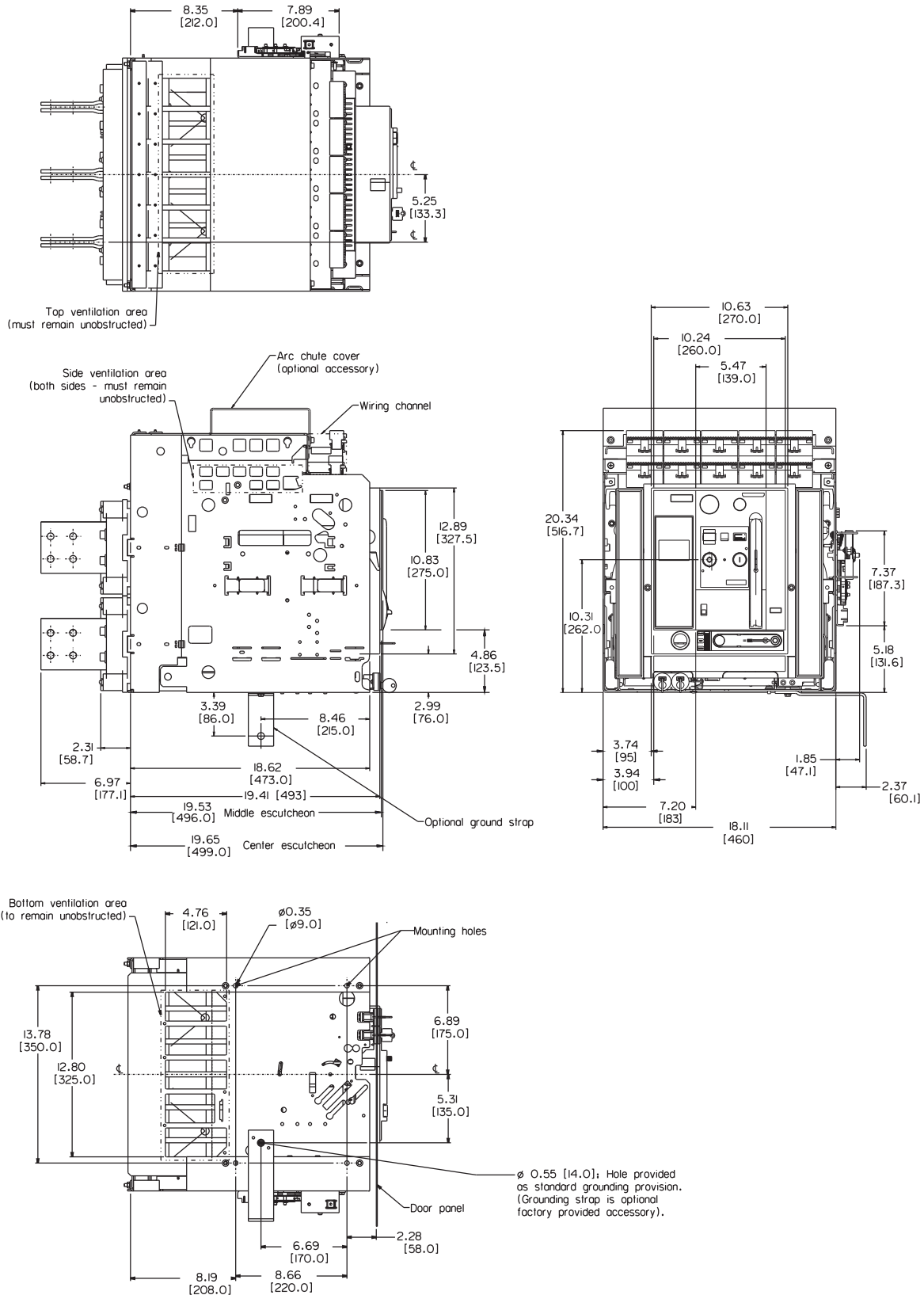

Low Voltage Circuit Breaker

UL 1066 Draw-out Non-fused Breaker

Dimensions

Frame Size 2

3200A

2000A

800/1600A

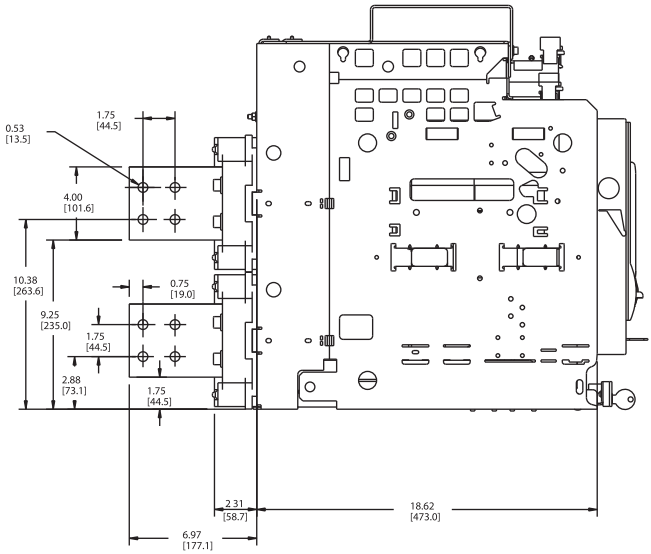
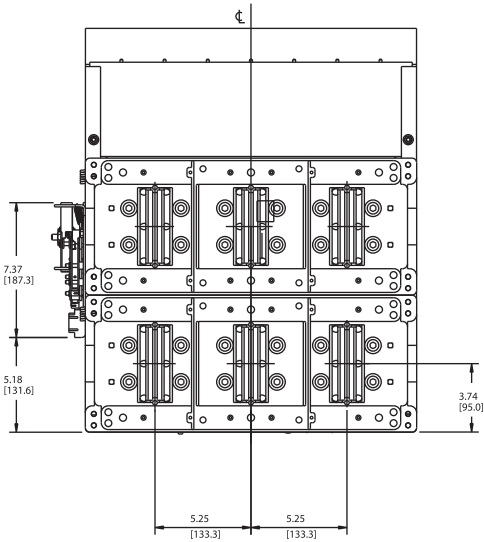
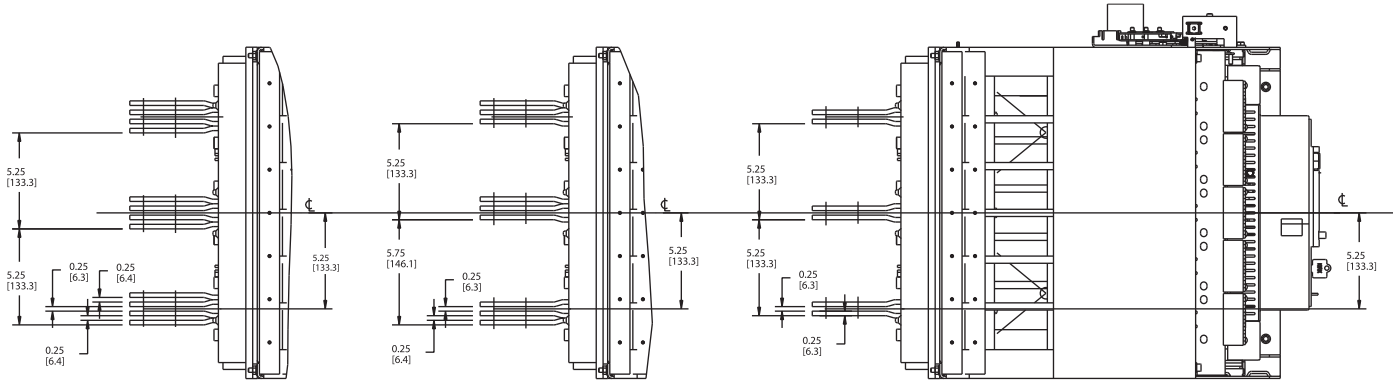

Low Voltage Circuit Breaker

UL 1066 Draw-out Non-fused Breaker

Dimensions

Frame Size 2

Horizontal Main Bus Connectors

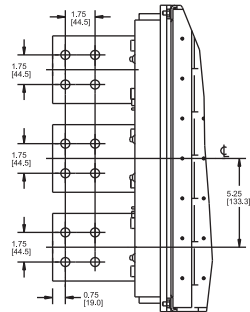

Vertical Main Bus Connectors

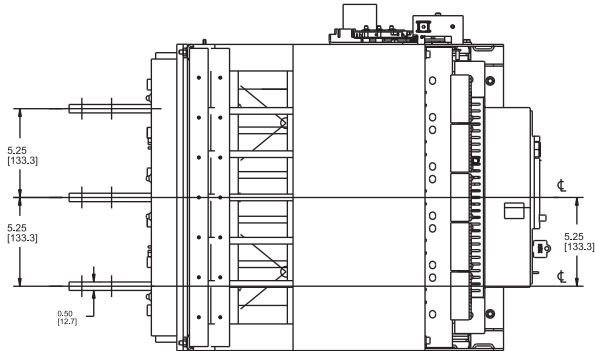

Horizontal Main Bus Connectors

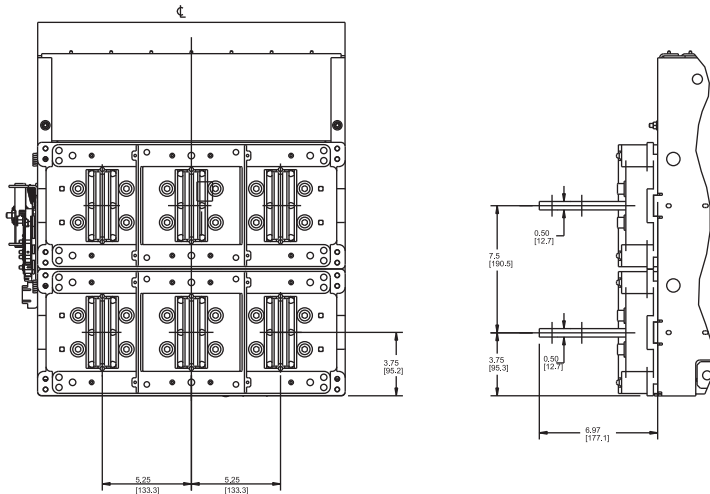

Vertical Main Bus Connectors

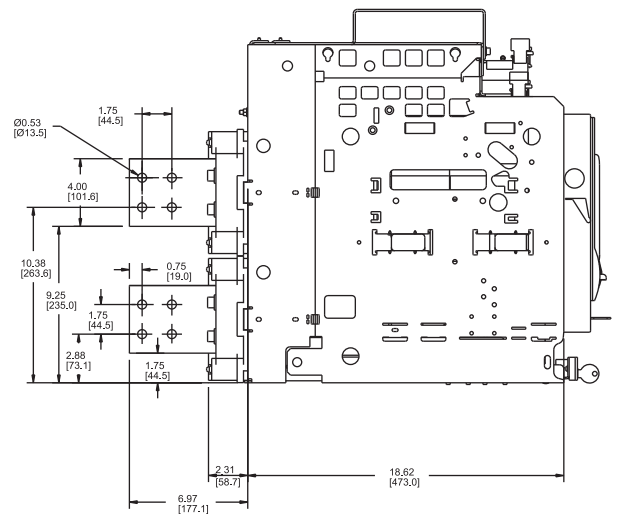

NOTE:

Rotatable main bus connectors are only available under the following conditions:

- (1) Only acceptable for FS2 800A – 2000A Frame Sizes
- (2) Only acceptable for short circuit ratings of 85kAIC or less

Low Voltage Circuit Breaker

UL 1066 Draw-out Non-fused Breaker

Dimensions

Frame Size 2

Charging, Racking and Draw-out

Lifting Point (Cradle only) Do not lift by other points.

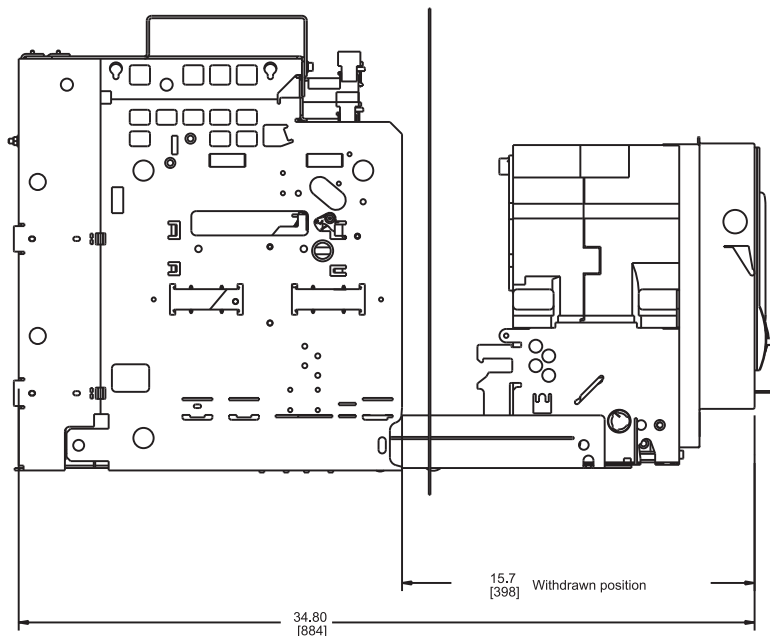
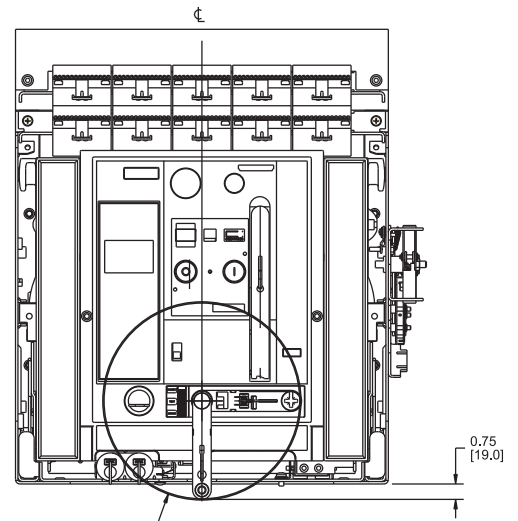
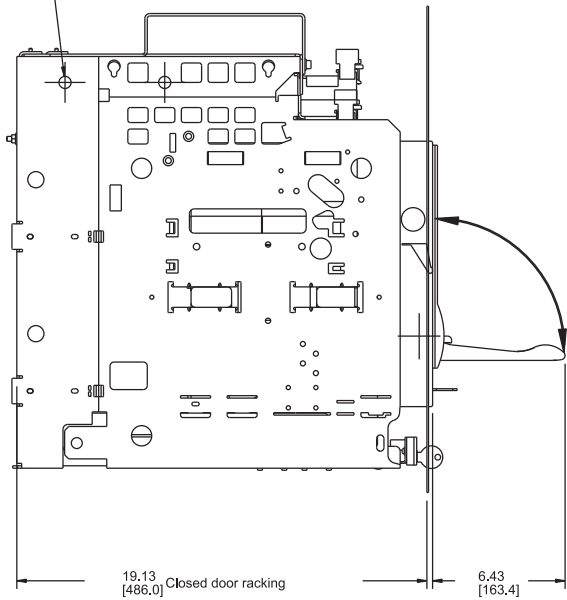

Low Voltage Circuit Breaker

UL 1066 Draw-out Fused Breaker

Frame Size 2

Dimensions

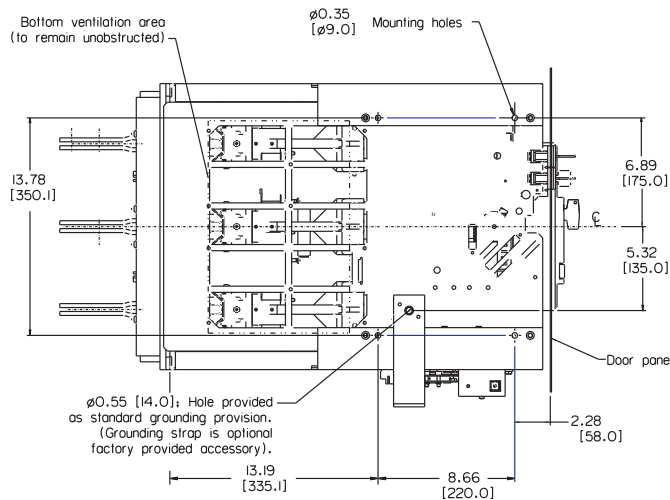
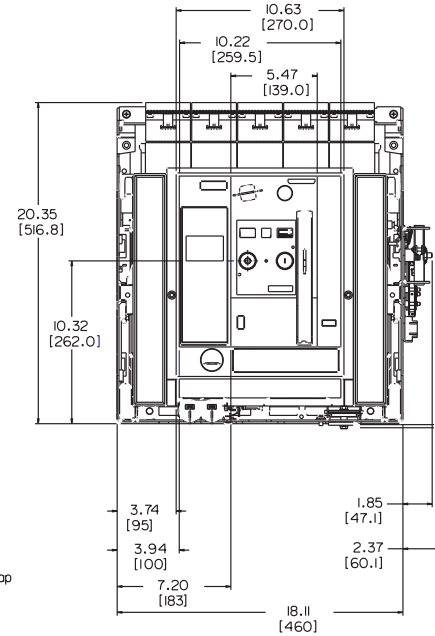
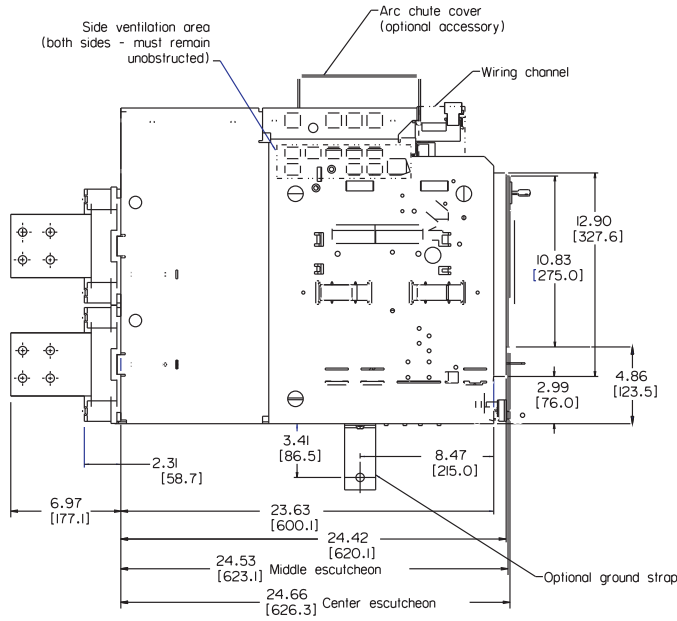
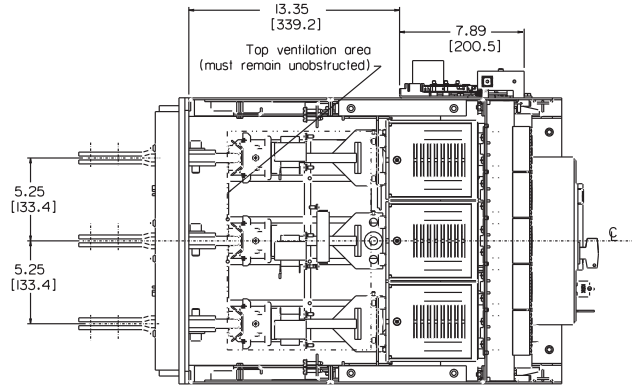

Low Voltage Circuit Breaker

UL 1066 Draw-out Fused Breaker

Frame Size 2

Dimensions

6
W1 POWER
CIRCUIT BREAKERS

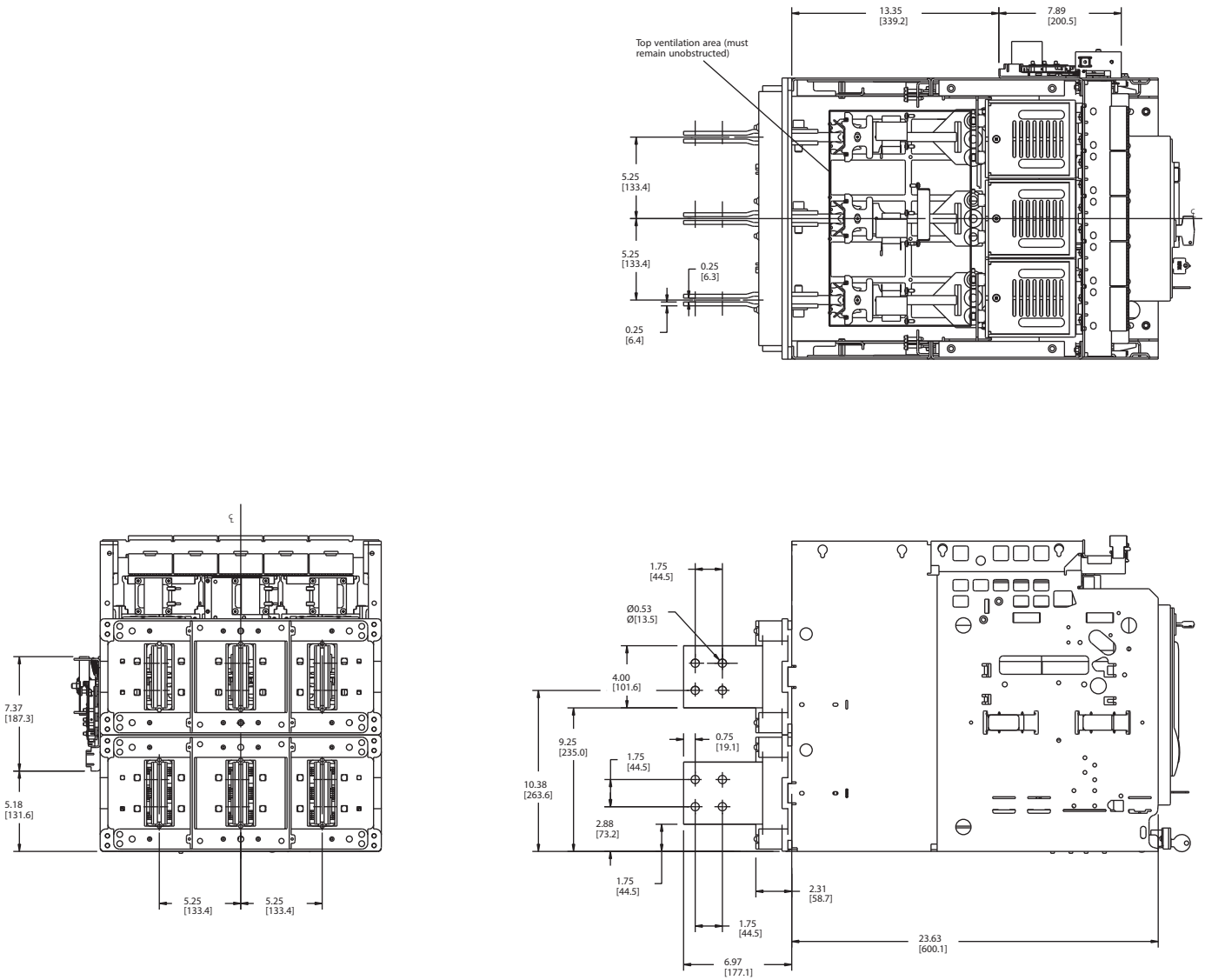

Low Voltage Circuit Breaker

UL 1066 Draw-out Fused Breaker

Dimensions

Frame Size 2

Charging, Racking and Draw-out

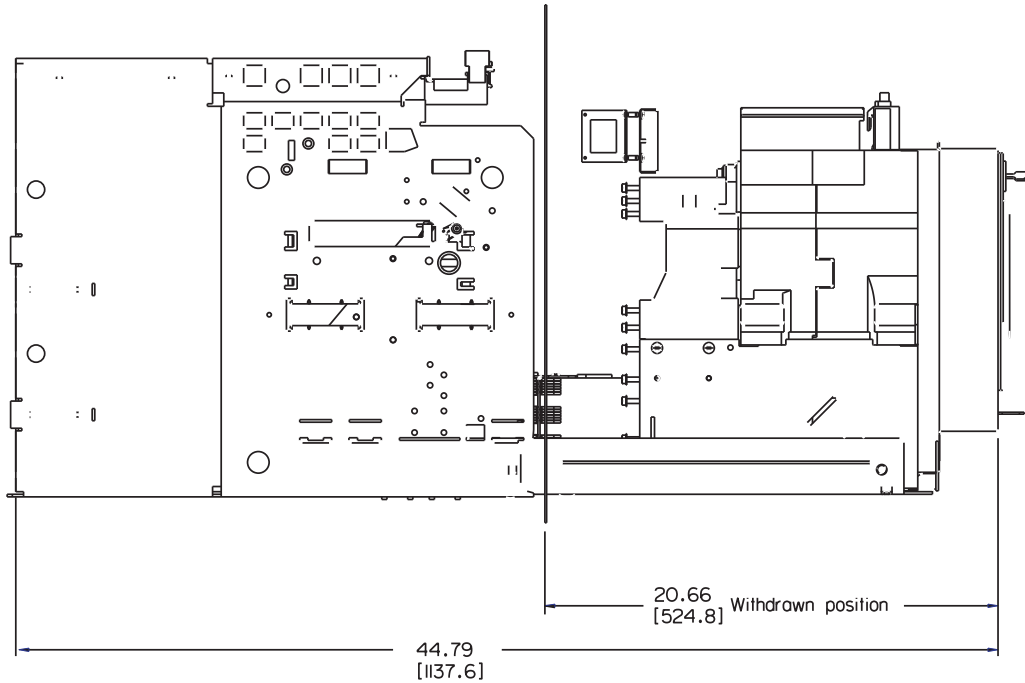
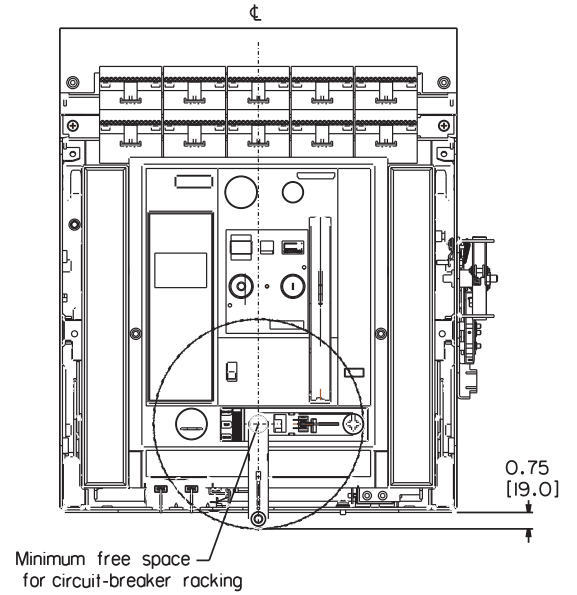
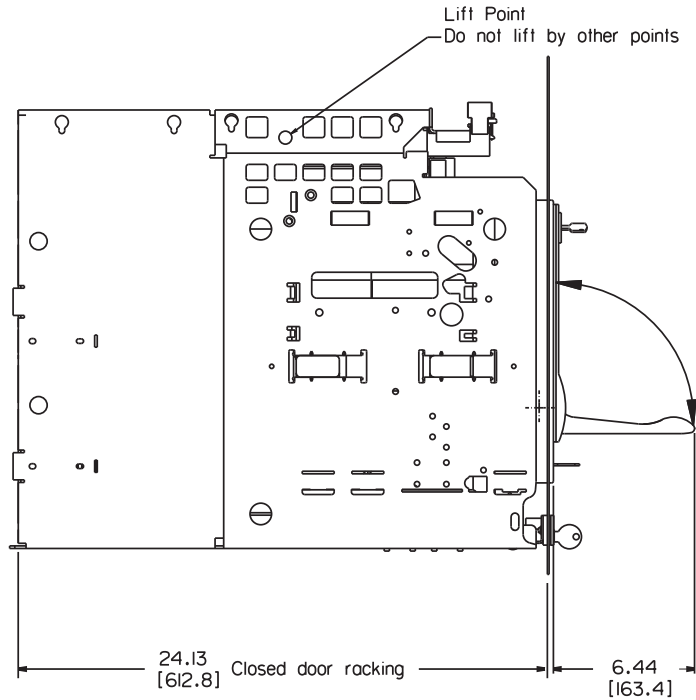

6

W1 POWER
CIRCUIT BREAKERS

Low Voltage Circuit Breaker

UL 1066 Draw-out Breaker

Dimensions

Frame Size 2

Door Cut-outs

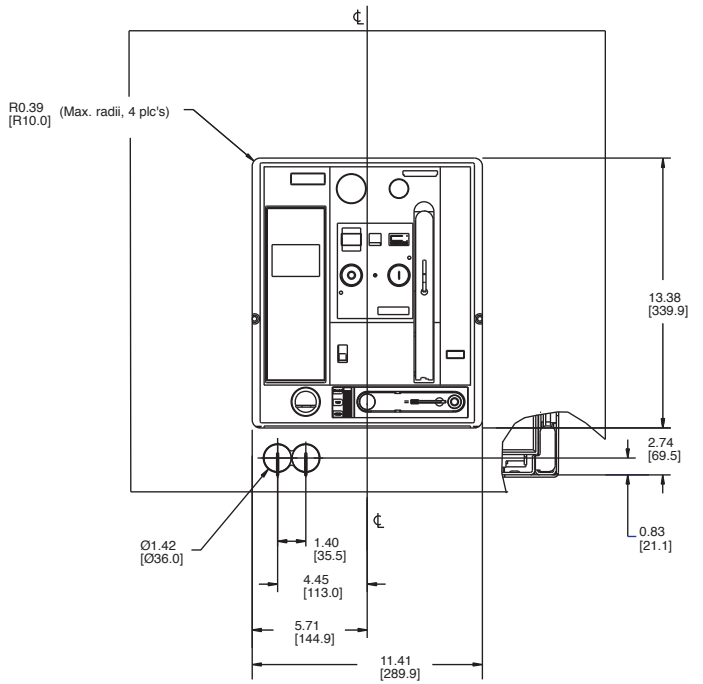
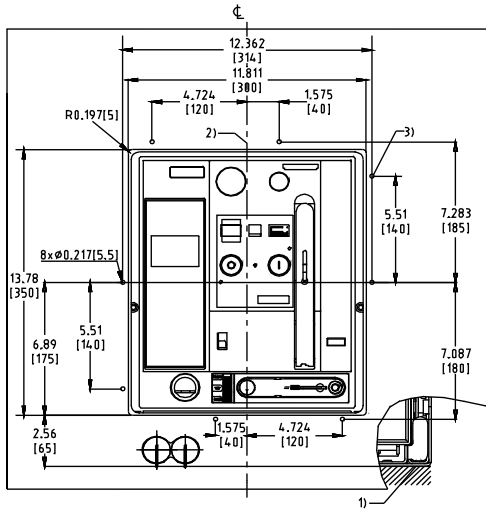

Door cut-out and mounting holes for Door Sealing Frame

Door cut-out (after mounting Door Sealing Frame)

6

W1 POWER
CIRCUIT BREAKERS

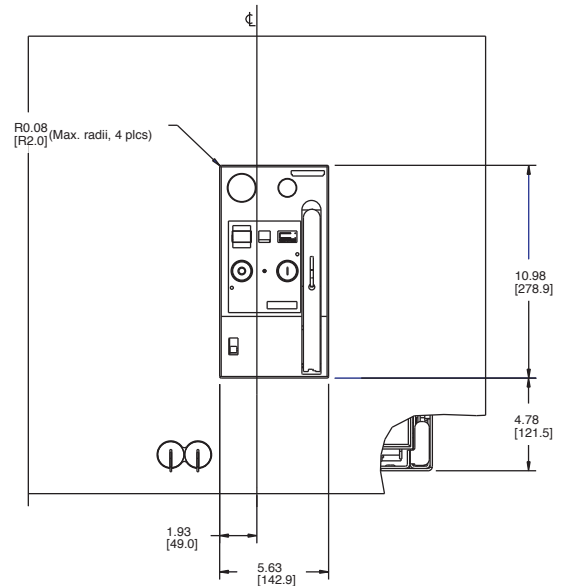
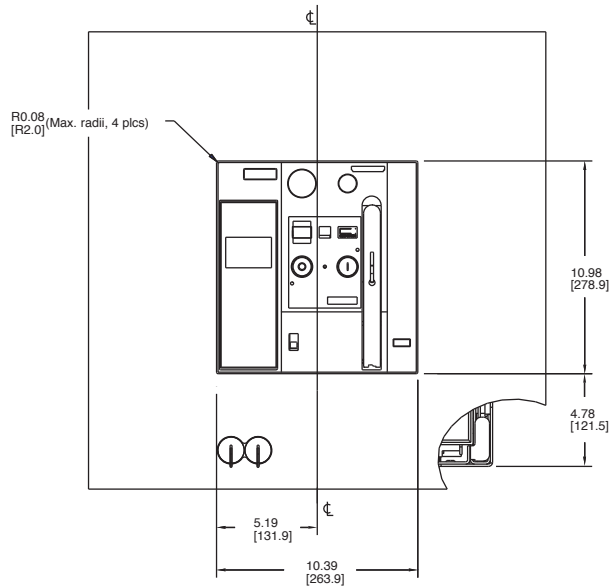

Door cut-out (Middle escutcheon visible)

Minimal door cut-out (Only center escutcheon visible)

- 1) Mounting surface of the circuit breaker or cradle.
- 2) Center of breaker front panel.
- 3) Drill eight holes for mounting door sealing frame.

Low Voltage Circuit Breaker

UL 1066 Draw-out Non-fused Breaker

Frame Size 3

Dimensions

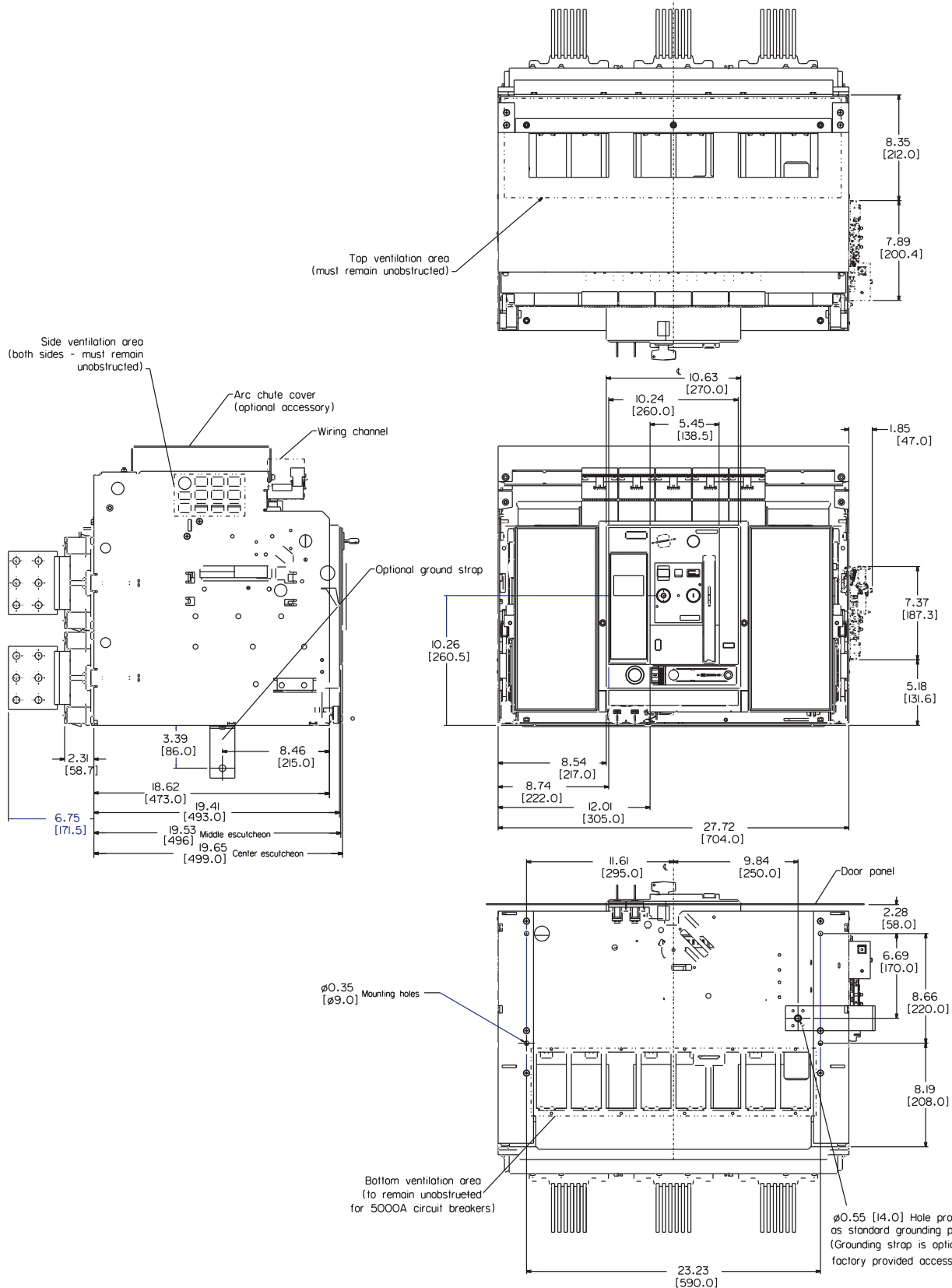

Low Voltage Circuit Breaker

UL 1066 Draw-out Non-fused Breaker

Dimensions

Frame Size 3

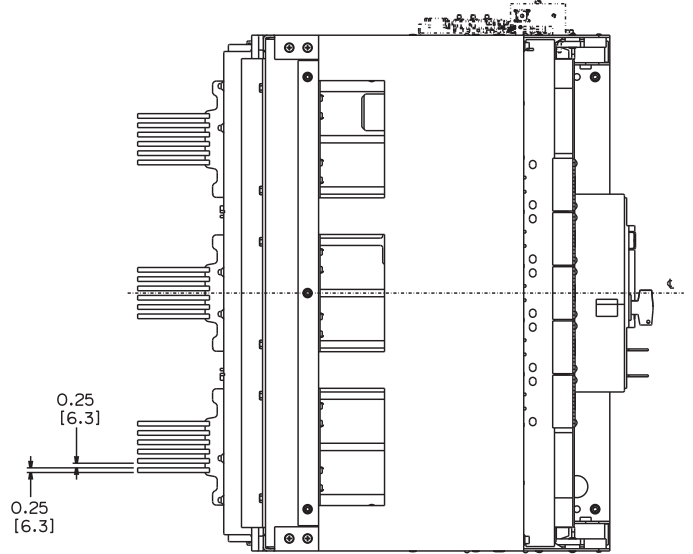

6
W1 POWER
CIRCUIT BREAKERS

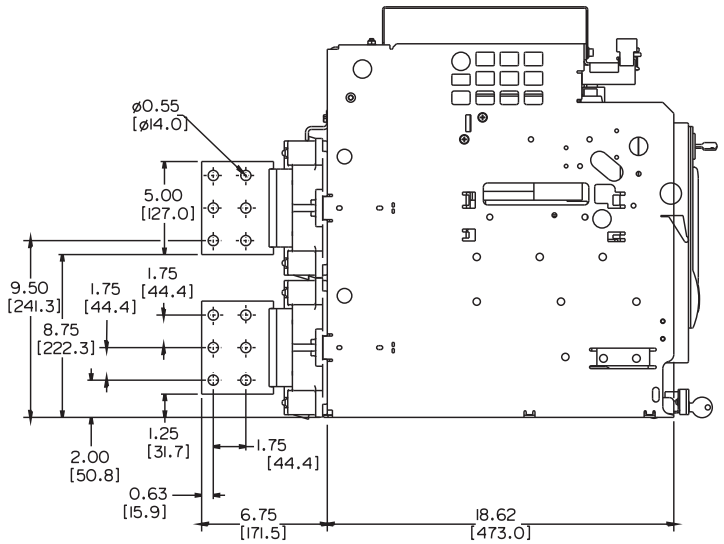
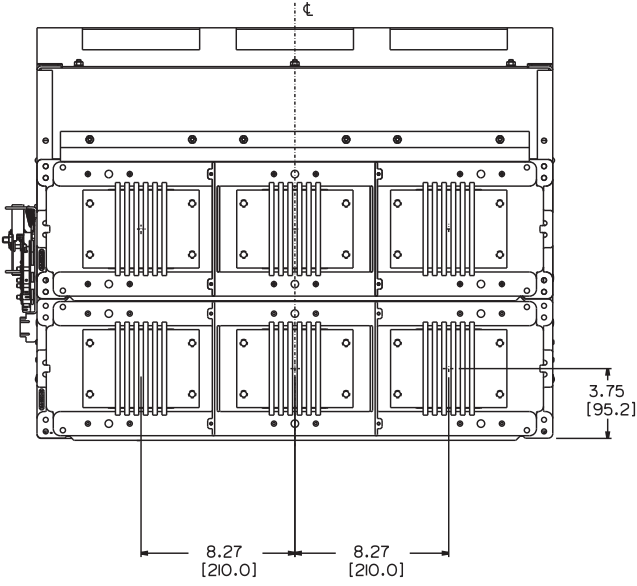

Low Voltage Circuit Breaker

UL 1066 Draw-out Non-fused Breaker

Dimensions

Frame Size 3

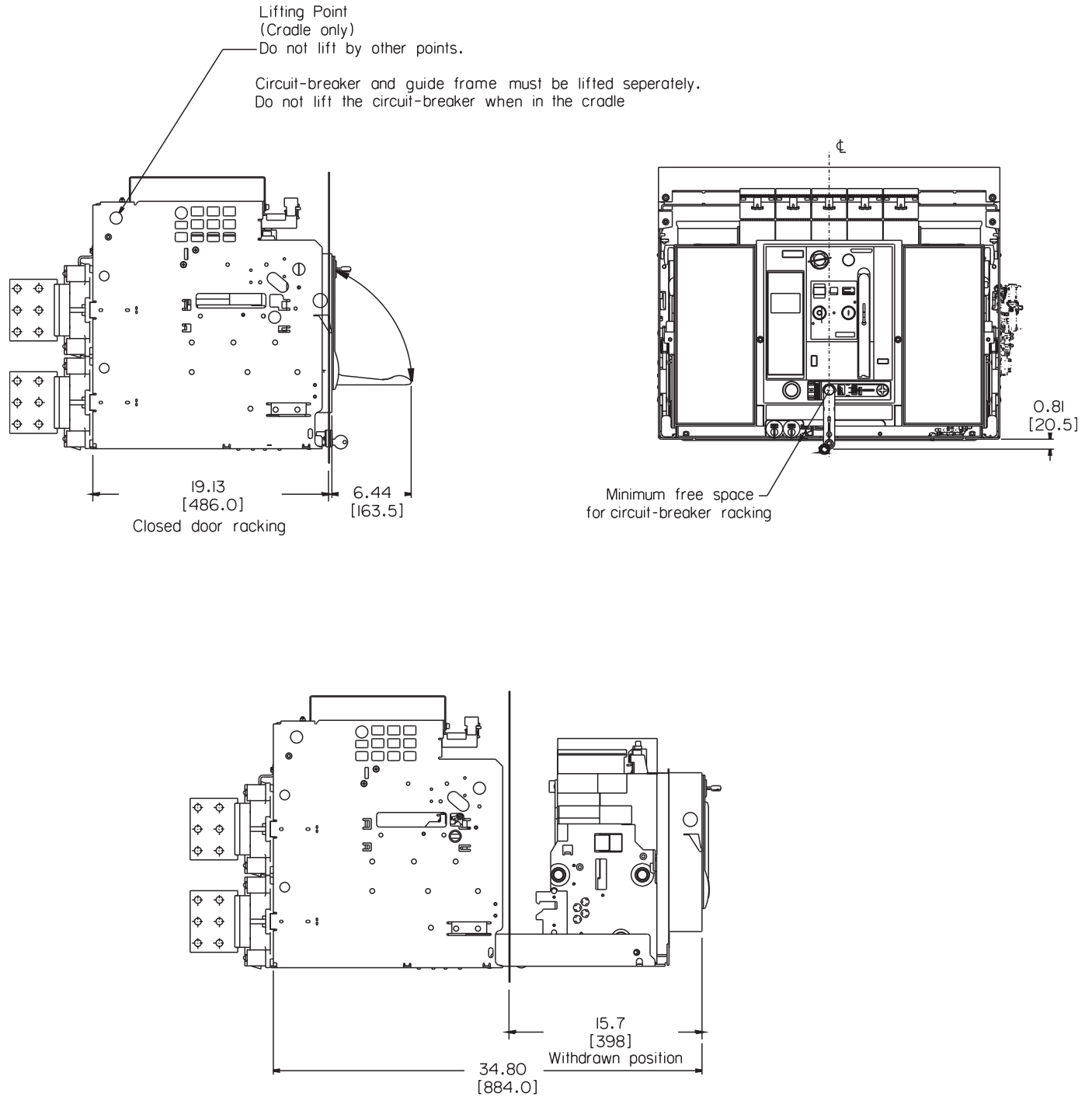

Low Voltage Circuit Breaker

UL 1066 Draw-out Fuse Carriage

Frame Size 3
Fuse Carriage

Dimensions

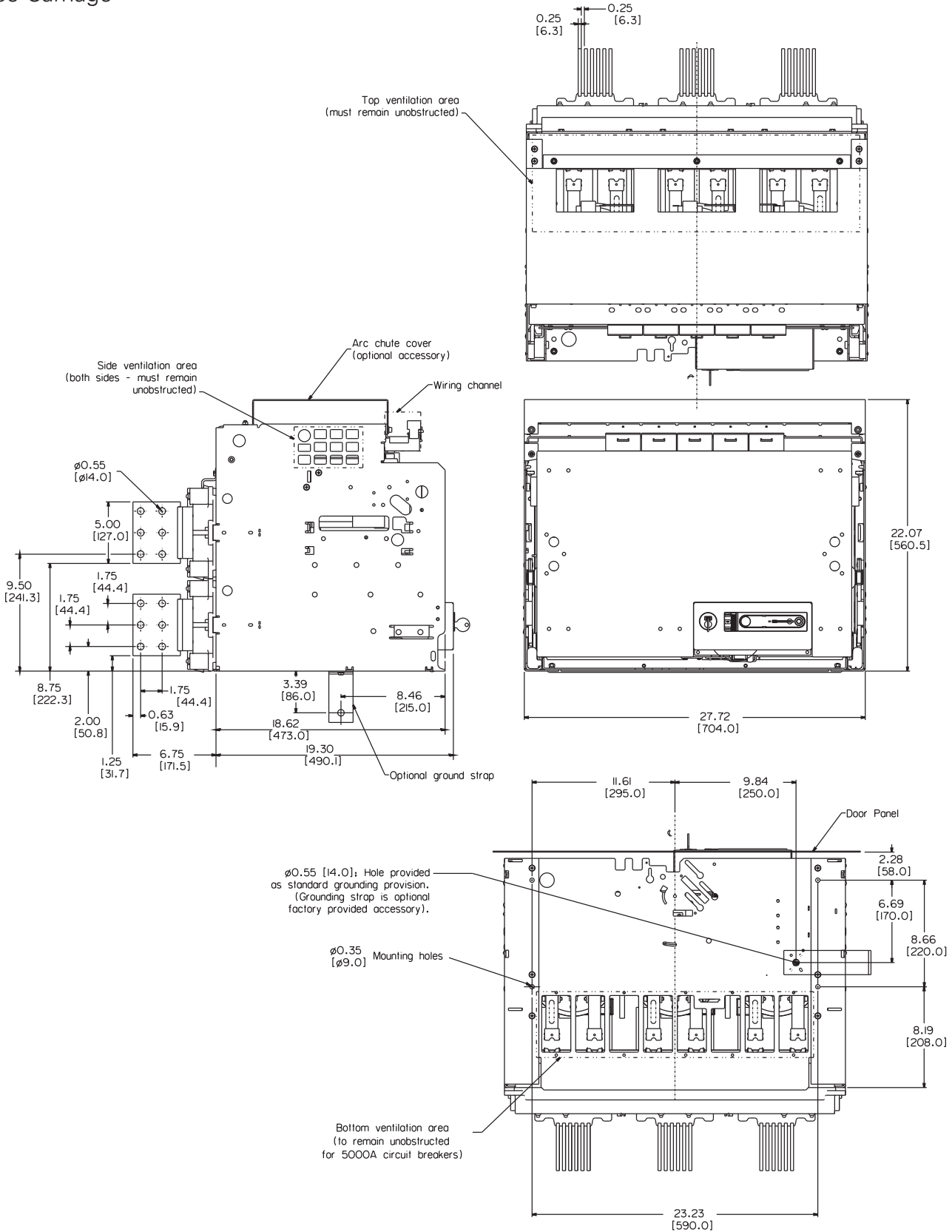

Low Voltage Circuit Breaker

UL 1066 Draw-out Fuse Carriage

Frame Size 3

Fuse Carriage Racking

Dimensions

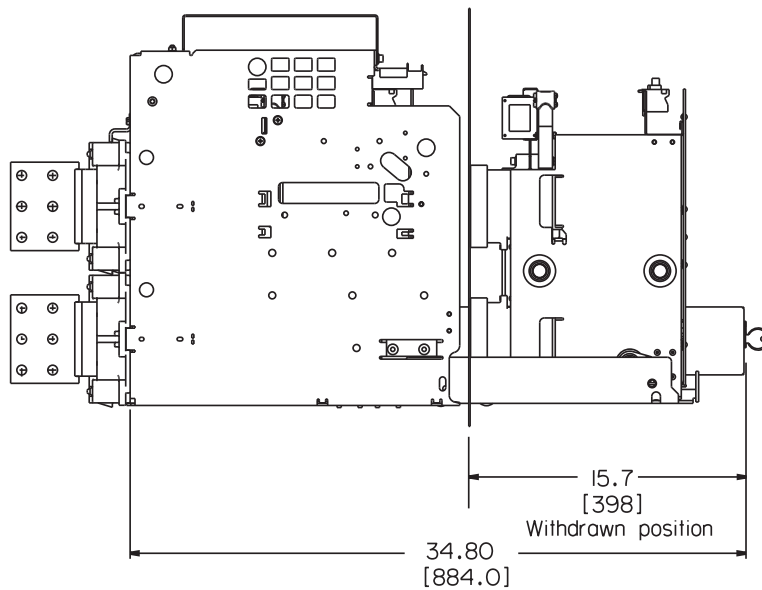
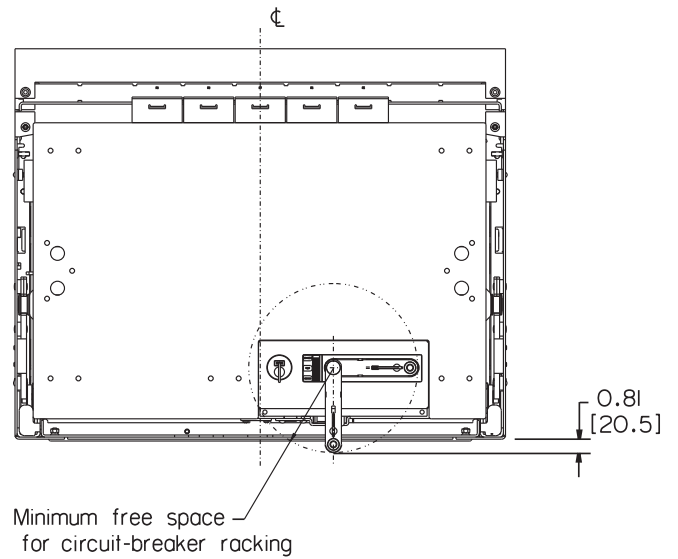
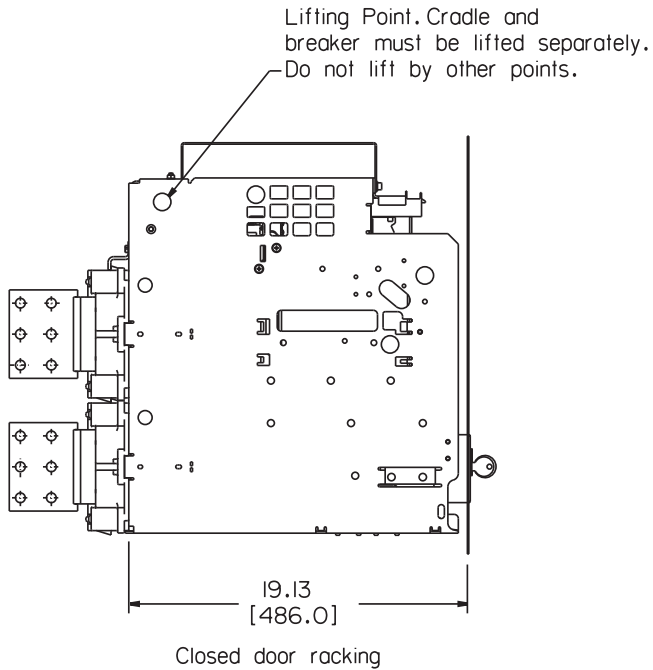

Low Voltage Circuit Breaker

UL 1066 Door Sealing Frame

Dimensions

Frame Size 3
Door Cut-outs

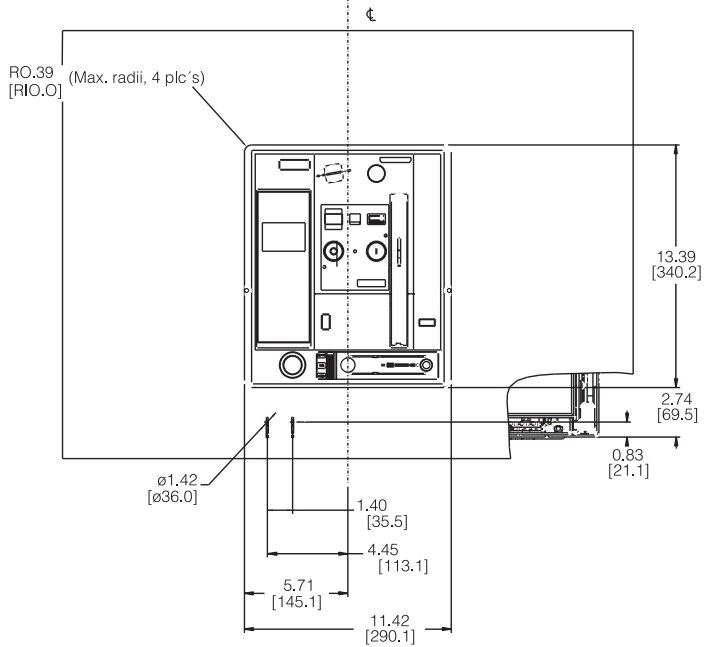
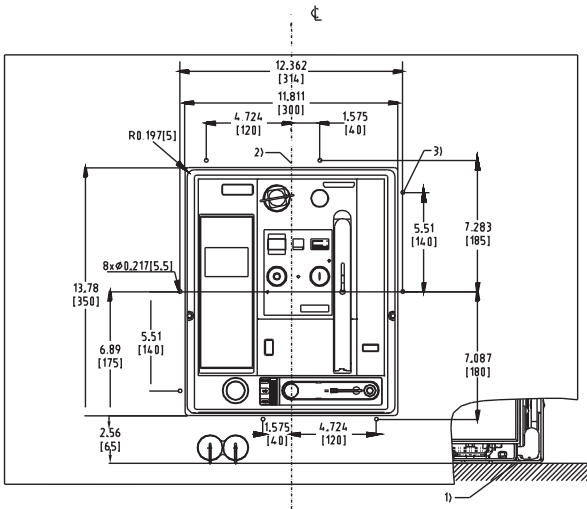

Door cut-out and mounting holes for Door Sealing Frame

Door cut-out (after mounting Door Sealing Frame)

6

W1 POWER
CIRCUIT BREAKERS

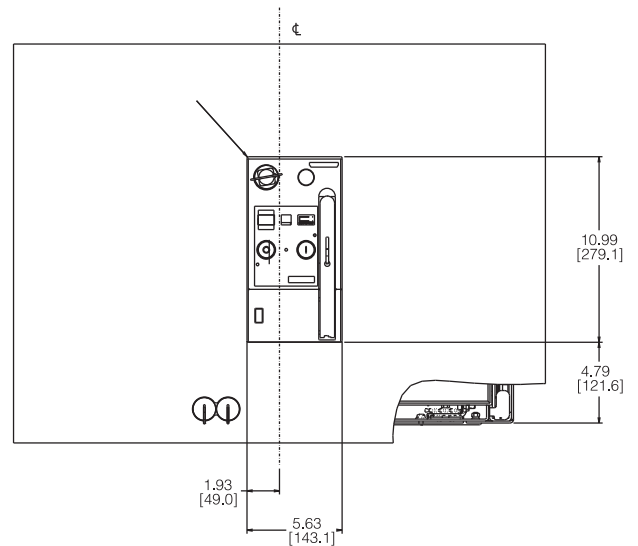
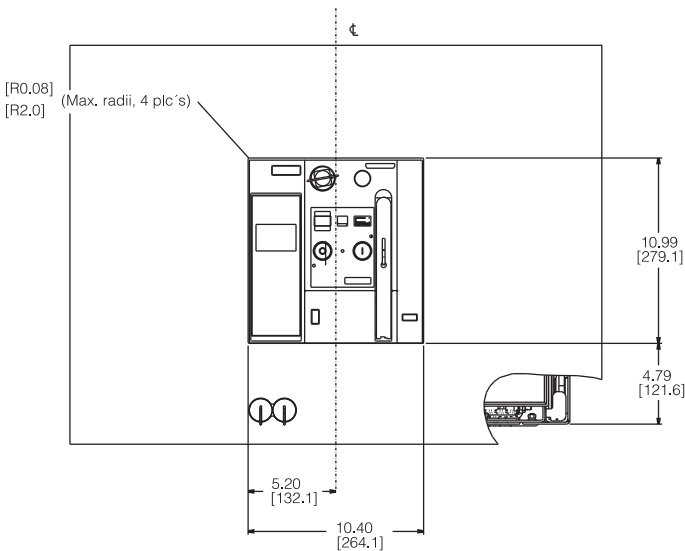

Door cut-out (Middle escutcheon visible)

Minimal door cut-out (Only center escutcheon visible)

- 1) Mounting surface of the circuit breaker or cradle.
- 2) Center of breaker front panel.
- 3) Drill eight holes for mounting door sealing frame.

Low Voltage Circuit Breaker

UL 1066 Draw-out

Frame Size 2 and 3
Door Cut-outs

Dimensions

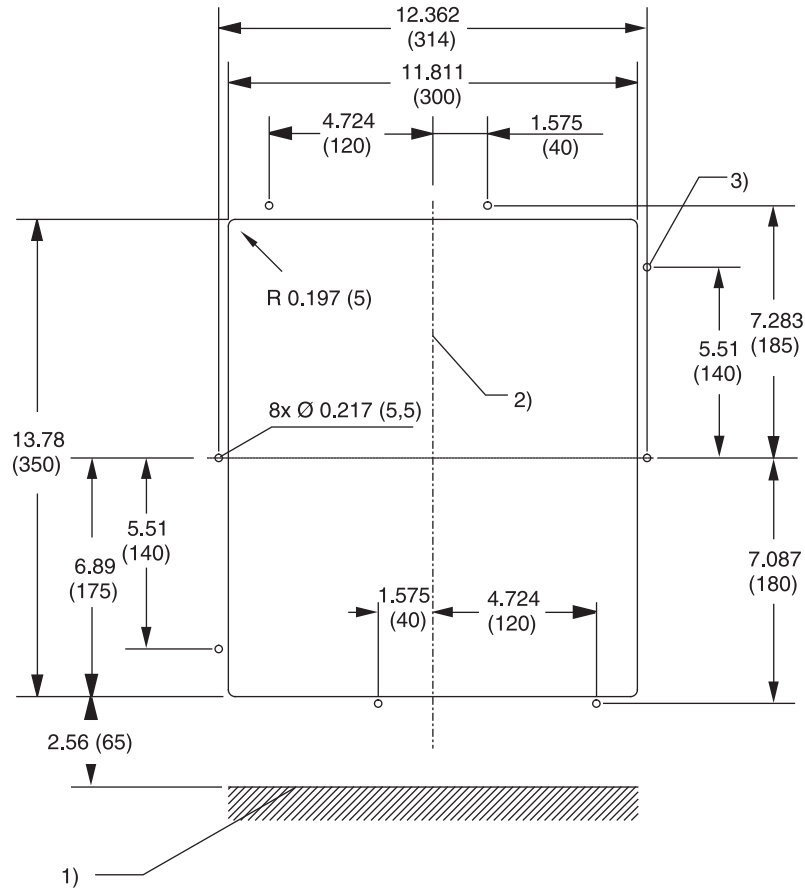

- 1) Mounting surface of the circuit-breaker or cradle.
- 2) Center of breaker front panel.
- 3) Drill eight holes for mounting door sealing frame.

WL Spare/Replacement Parts

Trip Units and Rating Plugs

Selection

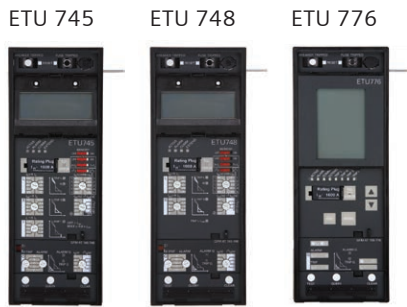

GFM A 745-748

GFM AT 745-748

GFM A 776

GFM AT 776

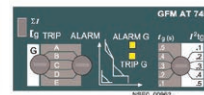
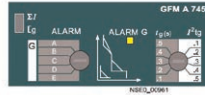

ETU catalog number	Trip unit functions	Protective settings	Replacement LCD displays	Ground fault alarm	Ground fault alarm and trip
WLETU745	LSI 1	WLTUSC55	WLLCD48	WLGFA48	WLGFM48
WLETU748	LS 1	WLTUSC55	WLLCD48	WLGFA48	WLGFM48
WLETU776 ²	LSI 1	WLTUSC76	Not replaceable	WLGFA76	WLGFM76
Trip unit with metering function²					
WLETU745MP	LSI 1	WLTUSC76	WLLCD48	WLGFA48	WLGFM48
WLETU748MP	LS 1	WLTUSC76	WLLCD48	WLGFA48	WLGFM48
WLETU776MP ²	LSI ²	WLTUSC76	Not replaceable	WLGFA76	WLGFM76

Overload Protection

L – Long Time Pick-up and Delay

S – Short Time Pick-up and Delay

I – Instantaneous Trip

G – Ground Fault Pick-up and Delay (Accessory sold separately)



Rating plug

Rating plug

Catalog number	Ampere rating	Catalog number	Ampere rating	Catalog number	Ampere rating	Catalog number	Ampere rating
WLRP200	200A	WLRP400	400A	WLRP800	800A	WLRP2500	2500A
WLRP225	225A	WLRP450	450A	WLRP1000	1000A	WLRP3000	3000A
WLRP250	250A	WLRP500	500A	WLRP1200	1200A	WLRP3200	3200A
WLRP300	300A	WLRP600	600A	WLRP1250	1250A	WLRP4000	4000A
WLRP315	315A	WLRP630	630A	WLRP1600	1600A	WLRP5000	5000A
WLRP350	350A	WLRP700	700A	WLRP2000	2000A		

¹ Optional GF module sold separately.

² Metering function and ETU776 requires 24VDC supply.

WL Spare/Replacement Parts

Trip Unit Options

Selection



Handheld tester



24VDC power supply

Catalog number	
Trip unit test equipment	
WLTS	Hand held tester for Electronic Trip Unit, Fixed LSIG pick-up
WLTSC	Replacement cable for WLTS Test Unit
24Vdc power supply	
WLSITOP25	24Vdc ETU and COMM power supply, 2.5A SITOP Power, Class 2
WLSITOP1	24Vdc ETU and COMM power supply, 3.8A SITOP Power, Class 2

WL Spare/Replacement Parts

Secondary Disconnects

Selection

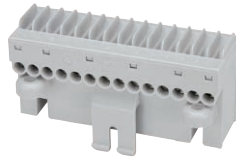

Compression screw connector
WLGAXPLUGP



Spring load connector
WLGAXPLUGT

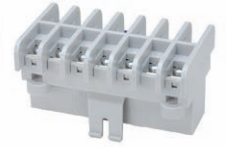

Ring lug connector
WLGAXPLUGR

Catalog number	
WLGAXPLUGP	Secondary Disconnect - Compression Screw
WLGAXPLUGL	Secondary Disconnect - Low-Profile Compression Screw
WLGAXPLUGT	Secondary Disconnect - Tension Terminal
WLGAXPLUGR	Secondary Disconnect - Ring Terminal
Secondary disconnect breaker frame mount	
WLCNMD	Auxiliary Contact on Drawout Breaker (Knife Block)
WLTERMBLKUL	Pull Apart Terminal Block w/ 1M leads for UL489 Fixed Mount Breaker
WLCNMDA	Block for Extending Height of Secondary Disconnect/WLCNMD
Secondary disconnect coding kit (UL489 only)	
WLCODEKITUL	Secondary disconnect coding kit for fixed mounted breaker
WL crimp lugs	
WL10RL	Crimp Lugs (70) for WLGAXPLUGR - #10 AWG



Low-profile screw connector
WLGAXPLUGL



Knife Blade Contact Block
WLCNMD



WLTERMBLKUL



Extends Height of WLCNMD
WLCNMDA

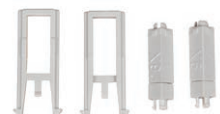

Coding Kit
WLCODEKITUL

6

WL POWER
CIRCUIT BREAKERS

WL Spare/Replacement Parts

Cradle Frame Accessories

Selection

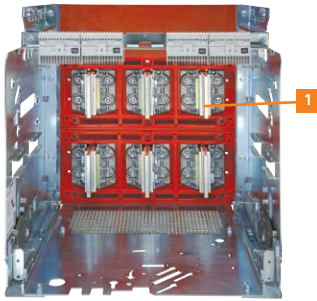

Arc Chute Cover

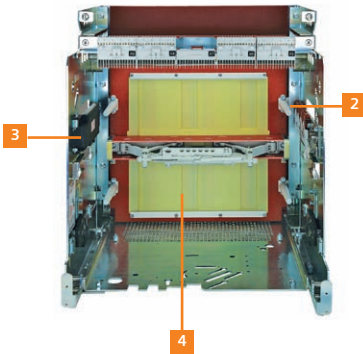

Catalog number		
1	Stationary primary bus-bar disconnect terminals (consists of 1 bus-bar pole only)	
	WLGST15123LI Stab tip replacement kit - 800A/1200A, FS1, Line Side	
	WLGST10163LD Stab tip replacement kit - 800A/1200A/1600A, FS2, Load Side	
	WLGST10163LL Stab tip replacement kit - 800A/1200A/1600A, FS2, Line and Load Side	
	WLGST15203LL Stab tip replacement kit - 1200A, FS2, Line and Load Side	
	WLGST15203LD Stab tip replacement kit - 2000A - 800A/1200A, FS2, Load Side	
	WLGST30323LL Stab tip replacement kit - 2500A/3000A, FS2, Line and Load Side	
WLGST30503LL Stab tip replacement kit - 4000A/5000A, FS3, Line and Load Side		
Cradle arc chute cover		
WLGARC1UL 3P Arc chute cover, UL489 FS1, Class S/H/L		
WLGARC2 3P Arc chute cover ANSI FS2, Class N/S/H/L		
WLGARC2UL 3P Arc chute cover, UL489 FS2, Class S/L		
WLGARCF2 3P Arc chute cover, ANSI FS2, Class F Fused		
WLGARC3 3P Arc chute cover, ANSI/UL489 FS3, Class H/L/F		
WL4GARC2 4P Arc chute cover FS2		
WL4GARC3 4P Arc chute cover, FS3		
2	MOC – Mechanism operated contacts (for draw-out breaker)	
	WLMOC MOC with 4NO + 4NC, Test and Connect Position, FS1/FS2	
	WLMOCC MOC with 4NO + 4NC, Connect Position, FS1/FS2	
	WLMOC3 MOC with 4NO + 4NC, Test and Connect Position, FS3	
	WLMOCC3 MOC with 4NO + 4NC, Connect Position, FS3	
	(for fixed mounted circuit breakers)	
	WLMOCUL1 MOC with 4NO + 4NC, FS1 Fixed	
	WLMOCUL MOC with 4NO + 4NC, FS2/FS3 Fixed	
	3	TOC – Truck operated contacts
		WLGSGSW111 Truck Operated Contact (1Conn-1Test-1Disconn)
WLGSGSW321 Truck Operated Contact (3Conn-2Test-1Disconn)		
WLGSGSW6 Truck Operated Contact (6Conn)		
4	Isolation shutters	
	WLG3SHUT1L FS1 3-Pole Shutter for Class S,H,L	
	WLG3SHUT2L FS2 3-Pole Shutter for Class N,S,H,L	
	WLG3SHUT2F FS2 3-Pole Shutter for Class F	
	WLG3SHUT2M FS2 3-Pole Shutter for Class C	
	WLG3SHUT3L FS3 3-Pole Shutter for Class L,F,H	
	WLG3SHUT3M FS3 3-Pole Shutter for Class C,M	
	WLG3SHUT3FC FS3 3-Pole Shutter for Fuse Carriage	
	WLG4SHUT2L FS2 4-Pole Shutter for Class S,H,L	
	WLG4SHUT3L FS3 4-Pole Shutter for Class H,L	

WL Spare/Replacement Parts

Cradle Frame

Selection

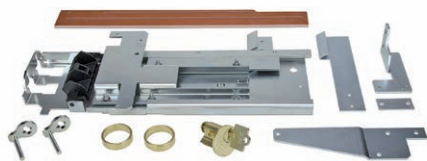

Key Interlocking
(Drawout)



Mechanical Interlock



Cradle Frame Heater
WLGHEAT

Catalog number

WLGHEAT	Cradle frame heater
Locking devices mounted on the cradle frame	
WLDLKRK	Kirk Key – Lock breaker in OPEN position (FS2, FS3 only)
WLDLDRK	Double-Kirk Key – Lock breaker in OPEN position (FS2, FS3 only)
WLDLSUP	Superior – Lock breaker in OPEN position (FS2, FS3 only)
WLDLSUP	Double Superior – Lock breaker in OPEN position (FS2, FS3 only)
WLDLPR	Provision Only – Lock breaker in the OPEN position (FS1, FS3 only)
WLDLDPR	Provision Only – Double lock breaker in the OPEN position (FS2, FS3 only)
WLDRLC	Locking device against opening the cubicle door when breaker is in connect position, FS1 Only
WLDRLC1	Locking device against opening the cubicle door when breaker is in connect position, FS2, FS3
WLDRLC5UL	Locking device against moving/racking the breaker when the cubicle door is in connect position, FS2, FS3
Mechanical interlock devices	
(Mechanical interlock cable ships with 2.0m Bowden Cable)	
WLNTLK	For FS1, FS2, FS3 Draw-out breaker
WLNTLKF1	FS1 Fixed mounted circuit breaker
WLNTLK23	FS2 and FS3 Fixed mounted circuit breaker
WLNTLWIRE2	Interlock Cable (2.0m Bowden Cable)
WLNTLWIRE3	Interlock Cable (3.0m Bowden Cable)
WLNTLWIRE4	Interlock Cable (4.5m Bowden Cable)
WLNTLWIRE5	Interlock Cable (6.0m Bowden Cable)

WL Spare/Replacement Parts

Metering CT Units

Selection



3 phase metering CT, guide frame mounted

Catalog number	Frame	Ratio
WLG8005MCT1	FS1	800:5
WLG12005MCT1	FS1	1200:5
WLG8005MCT2	FS2	800:5
WLG10005MCT2	FS2	1000:5
WLG12005MCT2	FS2	1200:5
WLG16005MCT2	FS2	1600:5
WLG20005MCT2	FS2	2000:5
WLG30005MCT2	FS2	3000:5
WLG32005MCT2	FS2	3200:5
WLG20005MCT3	FS3	2000:5
WLG30005MCT3	FS3	3000:5
WLG32005MCT3	FS3	3200:5
WLG40005MCT3	FS3	4000:5
WLG50005MCT3	FS3	5000:5

Single phase metering CT

Catalog number	Ratio
WLG800NMCT23	800:5
WLG1200NMCT23	1200:5
WLG1600NMCT23	1600:5
WLG2000NMCT23	2000:5
WLG3000NMCT23	3000:5
WLG3200NMCT23	3200:5
WLG4000NMCT23	4000:5
WLG5000NMCT23	5000:5

WL Spare/Replacement Parts

Ground Fault and Current Sensors

Selection



Modified differential CT



Neutral Sensor



Neutral Sensor with Bus Connector

Catalog number

Modified differential ground fault for source ground return

WLGMDGFCT2	FS2	1200:1	3 phase cradle mount
WLGMDGFCT3	FS3	1200:1	3 phase cradle mount
WLGMDGCT23	Iron core neutral sensor	1200:1	1 phase bus mount

External neutral CT for 4 wire residual ground fault

WLNCT2	3"	Without copper bus adapter (pass-thru mount)
WLNCT3	3 – 5" max. bus-bar size	Without copper bus adapter (pass-thru mount)

WLNCT2CB	For 3"	With copper bus adapter for bus connection
WLNCT3CB	For 3" – 5" max. bus-bar size	With copper bus adapter for bus connection

WL Spare/Replacement Parts

Circuit Breaker Accessories

Selection



Shunt Trip Coil



Auxiliary Contact



Ready-to-Close Contact



Bell Alarm Reset Coil



Bell Alarm Contacts



Operations Counter

Catalog number	
Shunt trip release	
WLST24	24Vdc, 3-cycle momentary duty
WLST48	48Vdc, 3-cycle momentary duty
WLST120	120Vdc/120Vac, 3-cycle momentary duty
WLST240	250Vdc/240Vac, 3-cycle momentary duty
WLSTCD24	24Vdc, continuous duty (UL 489 only)
WLSTCD48	48Vdc, continuous duty (UL 489 only)
WLSTCD120	120Vdc/120Vac, continuous duty (UL 489 only)
WLSTDC240	250Vdc/240Vac, continuous duty (UL 489 only)
(signal contactor 1st Shunt Trip)	
WLSTC	"NO" switch 3A-240Vac rating
(signal contactor second Shunt Trip)	
WLUVRC	"NO" switch 3A-240Vac rating
Auxiliary signaling switch	
WLAS2	2 NO and 2 NC contacts
WLAS4	4 NO and 4 NC contacts
Ready-to-close signal switch	
WLRTCS	1 form "A" NO contact 5A - 240Vac
Bell alarm	
Remote reset solenoid for Bell-alarm and trip indicator	
WLRSET24	24Vdc
WLRSET48	48Vdc
WLRSET120	125Vdc/120Vac
WLRSET240	250Vdc/240Vac
WLBA	Form "C" contact
Operation Counter	
Available only with spring charging motor option	
WLNUMCNT	Mechanical counter

WL Spare/Replacement Parts

Circuit Breaker Accessories

Selection



Undervoltage Trip Coil



Signal Contacts



Closing Coil

Catalog number	
Undervoltage trip release	
WLUV24	24Vdc, instantaneous trip
WLUV48	48Vdc, instantaneous trip
WLUV120	125Vdc/120Vac, instantaneous trip
WLUV240	250Vdc/240Vac, instantaneous trip
WLUV48	48Vdc, time delayed
WLUV120	125Vdc/120Vac, time delayed
WLUV240	250Vdc/240Vac, time delayed
Signal contactor for UV trip	
WLUVRC	"NO" switch 3A – 240Vac rating
Closing coil	
WLRCS24	24Vdc, 3 cycle momentary duty
WLRCS48	48Vdc, 3 cycle momentary duty
WLRCS120	125Vdc/120Vac, 3 cycle momentary duty
WLRCS240	250Vdc/240Vac, 3 cycle momentary duty

WL Spare/Replacement Parts

Circuit Breaker Accessories

Selection



Charging Motor



Breaker Current Sensor



Arc Chutes

Catalog number	
Spring charging motor	
WLELCMTR24	24Vdc, Charging motor
WLELCMTR48	48Vdc, Charging motor
WLELCMTR120	120Vdc/120Vac, Charging motor
WLELCMTR240	250Vdc/240Vac, Charging motor
WLELCMTR24S	24Vdc, Charging motor w/cut-off switch
WLELCMTR48S	48Vdc, Charging motor w/cut-off switch
WLELCMTR120S	125Vdc/120Vac, Charging motor w/cut-off switch
WLELCMTR240S	250Vdc/240Vac, Charging motor w/cut-off switch
WLMCOSW	Motor cut-off switch
ANSI UL 1066 breaker internal contact replacement kit	
RCS2N10	FS2 N-Group, 800A, 1600A
RCS2S10	FS2 S-Group, 800A, 1600A
RCS2H10	FS2 H-Group, 800A, 1600A
RCS2L10	FS2 L-Group, 800A, 1600A
RCS2S15	FS2 S-Group, 2000A
RCS2HF15	FS2 H and F-Group, 2000A
RCS2L15	FS2 L-Group, 2000A
RCS2S30	FS2 S-Group, 3200A
RCS2H30	FS2 H-Group, 3200A
RCS2L30	FS2 L-Group, 3200A
RCS3HF30	FS3 H and F-Group, 4000/5000A
RCS3L30	FS2 L-Group, 4000/5000A
Internal phase sensor (Rogowski coil)	
WLCT2	FS2 ANSI breaker kit for one breaker
WLCT3	FS3 ANSI breaker kit for one breaker
ANSI 1066 breaker arc chute replacement kit	
WLARC2	For FS2 ANSI breaker only
WLARC3	For FS3 ANSI breaker only
WLARCM3	For FS3 ANSI M-Class breaker only

6

WL POWER
CIRCUIT BREAKERS

WL Spare/Replacement Parts

Circuit Breaker Accessories

Selection

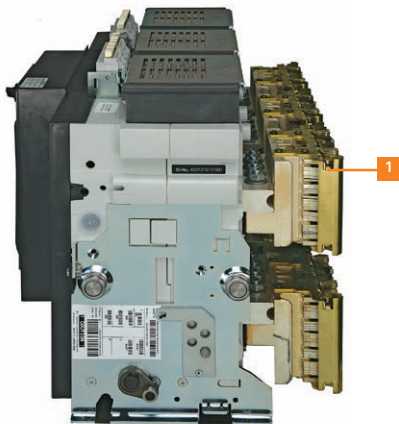

Fixed Breaker Connectors

1

Catalog number		Units
Circuit breaker finger cluster replacement kit		
WLFNGR1UL	For FS1 UL489 800A, 1200A	1 piece
WLFNGR10UL	For FS2 UL489 800, 1200, 1600A Class S&L	1 piece
WLFNGR15UL	For FS2 UL489 2000A, S&L	1 piece
WLFNGR30UL	For FS2 UL489 2500/3000A Class S&L	1 piece
WLFNGR30ULC	For FS2 UL489 1600/2000/2500/3000A Class C only	1 piece
WLFNGR10	For FS2 ANSI 800A, 1200A	1 piece
WLFNGR15	For FS2 ANSI 2000A	1 piece
WLFNGR30	For FS2 ANSI 3200A	1 piece
WLFCK3	For FS3 ANSI 4000A, 5000A	1 piece
WLFC6X1A	For FS1 UL489 800A, 1200A	6 pieces
WLFC6X10	For FS2 ANSI 800, 1600A	6 pieces
WLFC6X15	For FS2 ANSI 1200A	6 pieces
WLFC6X1B	For FS2 Fused	6 pieces
WLFC6X30	For FS2 ANSI, 3200A	6 pieces
WLFC6X3C	For FS2 C-Class	6 pieces
WLFC6X3A	For FS3 ANSI 4000A, 5000A	6 pieces
WLFC6X3B	For FS3 Fuse carriage	6 pieces
Circuit breaker bus connectors		
UL 489 Fixed Mount (Front mount Bus Connector)		
WLH1F12CONUL	FS1, 800-1200AF, 85kAIC at 480V maximum	6 pieces
WLL2F16CONUL	FS2, 1600AF, 100kAIC at 480V maximum	6 pieces
WLL2F20CONUL	FS2, 2000AF, 100kAIC at 480V maximum	6 pieces
WLL2F25CONUL	FS2, 2500AF, 100kAIC at 480V maximum	6 pieces
WLL2F30CONUL	FS2, 2500-3000AF, 100kAIC at 480V maximum	6 pieces
WLL3F50CONUL	FS3, 4000-5000AF, 100kAIC at 480V maximum	6 pieces
(Rear Vertical Bus Connector)		
WLH1R12CONUL	FS1, 800-2000AF, 100kAIC at 480 V maximum	6 pieces
WLL2R16CONUL	FS2, 800-1600AF, 100kAIC at 480V maximum	6 pieces
WLL2R20CONUL	FS2, 2000AF, 100kAIC at 480V maximum	6 pieces
WLL2R30CONUL	FS2, 2500-3000AF, 100kAIC at 480V maximum	6 pieces
WLC2R30CONUL	FS2, 800-3000A, 150kAIC at 480V max	6 pieces
WLC3R50CONUL	FS3, 4000-5000AF, 150kAIC at 480V maximum	6 pieces
Circuit breaker fix mount optional metric hardware		
WLMETRC	FS1 and FS2 M8x25 bolts and 6.3 washers	
WLMETRC3	FS3 M10X25 bolts and 6.3 washers	

WL Spare/Replacement Parts

Circuit Breaker Accessories

Selection

Locking Devices and Sealing Caps

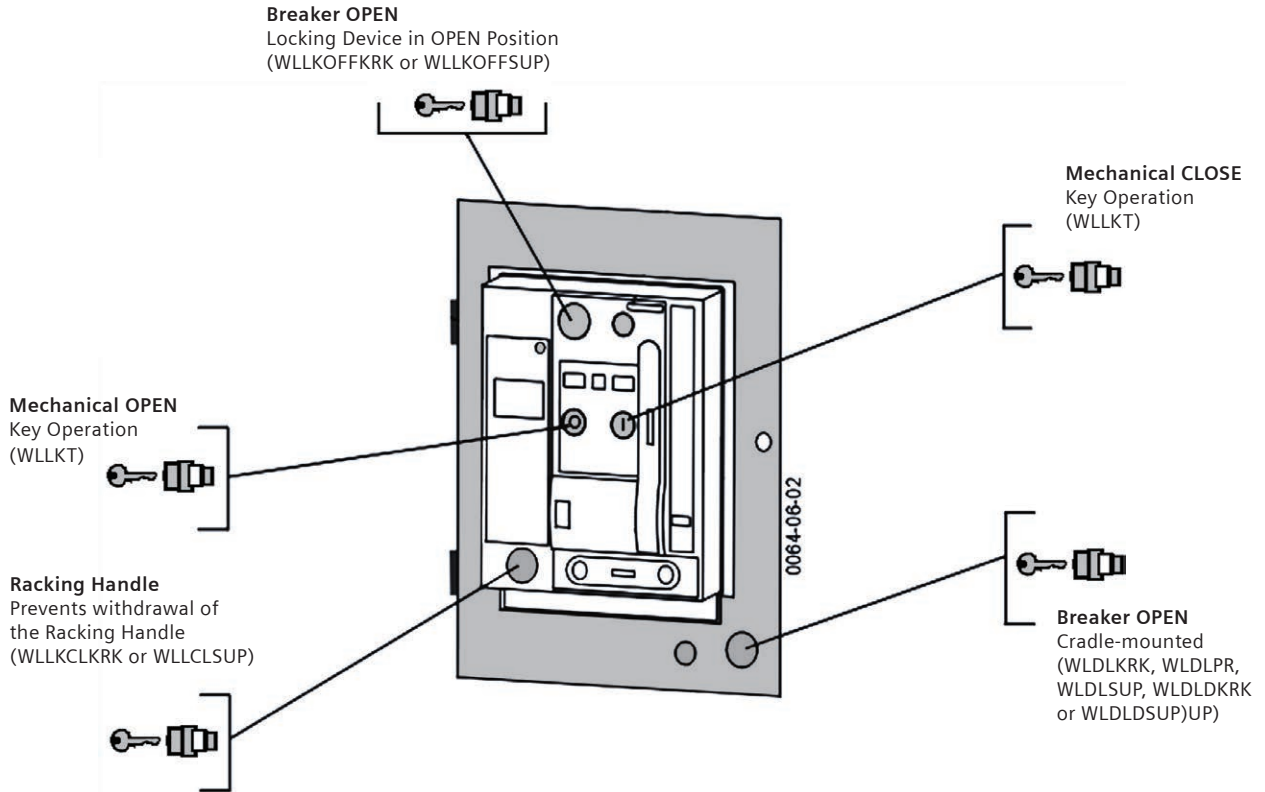

Padlocking Provisions

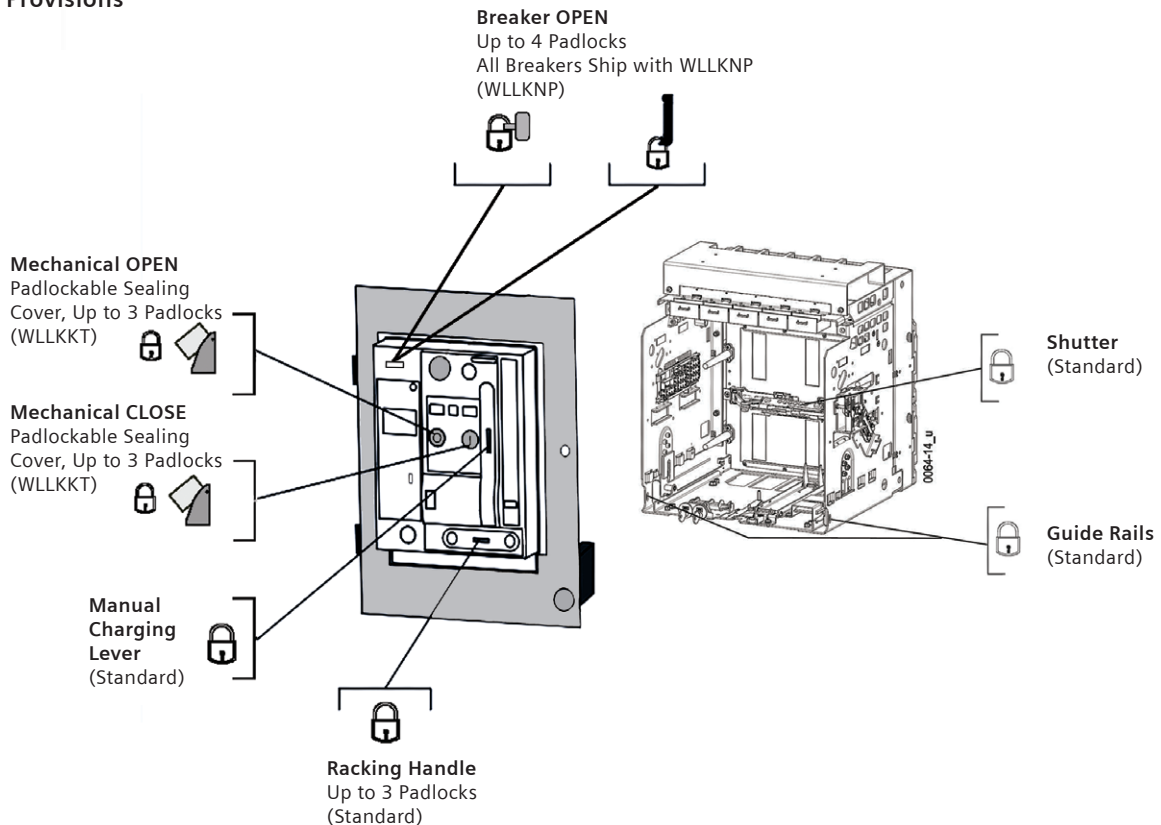

6

WL POWER
CIRCUIT BREAKERS

WL Spare/Replacement Parts

Options and Accessories

Selection



Breaker Open Lock
WLLKOFFKRK



Pushbutton Lock Outs
WLLKKT



Charge Handle Lock
WLHANDLC

Catalog number	
Breaker Locking Device	
WLLKOFFDRUL1	Door lock FS1 (locked when breaker is closed)
WLLKOFFDRUL3	Door lock FS2/FS3 (locked when breaker is closed)
WLLKOFFKRK	Kirk key (lock when breaker is open)
WLLKOFFSUP	Superior Key (lock when breaker is open)
WLLKNP	Provision only padlock (lock when breaker is open)
WLLKOFFPR	Provision only key lock (lock when breaker is open)
WLLKKT	Sealing/Locking cover for OPEN/CLOSE button w/cheat-hole
WLLKCLKRK1	Racking handle lock, FS1 - Kirk key
WLLKCKRK	Racking handle lock, FS2/FS3 - Kirk key
WLLKCLSUP1	Racking handle lock, FS1 - Superior key
WLLKCLSUP	Racking handle lock, FS2/FS3 - Superior key
WLLKCLPR	Racking handle lock, FS2/FS3 - Provision only
WLHANDLC	Charging handle padlock provision

6

WL POWER
CIRCUIT BREAKERS

Fuse Kits

Catalog number	
WL fuse replacement kits	
WLCLF0400	Breaker fuse kit FS2 400A (3 Fuses)
WLCLF0600	Breaker fuse kit FS2 600A (3 Fuses)
WLCLF0800	Breaker fuse kit FS2 800A (3 Fuses)
WLCLF0900	Breaker fuse kit FS2 900A (3 Fuses)
WLCLF1000	Breaker fuse kit FS2 1000A (3 Fuses)
WLCLF1200	Breaker fuse kit FS2 1200A (3 Fuses)
WLCLF1600	Breaker fuse kit FS2 1600A (3 Fuses)
WLCLF2000	Breaker fuse kit FS2 2000A (3 Fuses)
WLCLF2500	Breaker fuse kit FS2 2500A (3 Fuses)
WLCLF3000	Breaker fuse kit FS2 3000A (3 Fuses)
WLCLF3001	Carriage fuse kit FS3 3000A (3 Fuses)
WLCLF4000	Carriage fuse kit FS3 4000A (3 Fuses)
WLCLF5000	Carriage fuse kit FS3 5000A (3 Fuses)
WLCLF6000	Carriage fuse kit FS3 6000A (3 Fuses)

WL Spare/Replacement Parts

Options and Accessories

Selection



Sealing Frame
WLSF



Plexiglass Cover
WPGC



Lift Device
WLLFT

Catalog number	
WLEPEN	Emergency OPEN button (mushroom head)
WLDSF	Door sealing frame, FS2/FS3
WPGC	Door plexiglass cover, FS2/FS3
WLLFT	Lifting device (Yolk) 3 pole frames
WLLFT4	Lifting device (Yolk) 4 pole frames
WLHOIST	Breaker Lift Truck/Hoist
WLCHANDLE	Breaker manual charging handle replacement
WLCLUTCH	WL breaker shaft extension
WLBGREASE	WL circuit breaker maintenance grease
WLDMNT1	Breaker Foot Replacement Kit - FS1 Drawout
WLFMNT1	Breaker Foot Replacement Kit - FS1 Fixed
WLDMNT2	Breaker Foot Replacement Kit - FS2 Drawout
WLFMNT2	Breaker Foot Replacement Kit - FS2 Fixed
WLDMNT3	Breaker Foot Replacement Kit - FS3 Drawout
WLFMNT3	Breaker Foot Replacement Kit - FS3 Fixed
WLBCESTEST	WL circuit breaker certified test report
WLINTWIRE1	Ground fault wire harness replacement (ETU-to-X8)
WLINTWIRE2	CubicleBus wire harness replacement (ETU-to-X8)
Should it become necessary for the customer to return a WL circuit breaker frame for any reason, proper packaging is to be used to prevent damage to the product while in shipment.	
WLPFS1B	Packaging for FS1 Breaker
WLPFS2B	Packaging for FS2 Breaker
WLPFS2FB	Packaging for FS2 Fused Breaker
WLPFS3B	Packaging for FS3 Breaker

6

WL POWER
CIRCUIT BREAKERS

WL Spare/Replacement Parts

Communication Components

Selection



COM Device



BSS



CubicleBus Devices



BDA

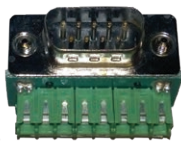

WLCOMBOARD

Catalog number	
Breaker communication module	
WLCM15M	PROFIBUS module COM15
WLCM15RET	PROFIBUS module COM15 w/ BSS
WLCM16MD	MODBUS module COM16
WLCM16RET	MODBUS module COM16 w/ BSS
WLCOMBOARD	COM16 RS485 adapter board (Modbus only)
Breaker status sensor	
WLBSS	Breaker status sensor for Profibus/Modbus
External I/O CubicleBus modules	
WLZSIMD	CubicleBUS Zone Selective Interlocking (ZSI) module
WLANLGCUB	CubicleBUS analog output module
WLRLYCUB	CubicleBUS digital output relay module w/ rotary switch
WLRLYCCUB	CubicleBUS digital output relay module (Configurable)
WLDGNCUB	CubicleBUS digital input module
Cables for CubicleBus modules	
WLCBUSCABLE02	CubicleBUS RJ45-M communication cable - 0.2 meters
WLCBUSCABLE1	CubicleBUS RJ45-M communication cable - 1 meter
WLCBUSCABLE2	CubicleBUS RJ45-M communication cable - 2 meters
WLCBUSCABLE4	CubicleBUS RJ45-M communication cable - 4 meters
WLCBUSCABLE9	CubicleBUS RJ45-M communication cable - 9 meters
External communication devices	
WLBdap	BDA plus, electronic trip unit parameterization
WLBdapWR	BDA power supply
WLBdapMNT	BDA perm mount cable to X8
Technical support literature	
WLULOPMAN1	Operation Manual for UL489 Breakers
WLOPMAN1	Operation Manual for UL1066/ANSI Breakers
TYZ:WL_RET_REP	Breaker return, repair and RGA

WL Spare/Replacement Parts

Communication Components

Selection

Typical certified test report

SIEMENS

Ft. Worth, TX

WL Low Voltage Power Circuit Breaker Certified Test Report

Catalog #:

Breaker Type:

CBID:

FS: Frame Rating:

Base Frame ID:

Interrupt Cap:

Trip Unit ID:

Test Station:

Rating Plug:

Production Order:

Sold To:

Ship To:

Test Date: **7/15/2014**

- Identify Test Performed - Incl. Programming, Labeling, Catalog Order Check
- Mechanical Accessory Tests Performed - Incl. Manual Mechanism Charging, Anti-Pumping, Trip/Close Solenoids, UVR, Motor, Aux. Switch Bell Alarms etc. (as per installed)
- Dielectric / Hi-Pot Tests Performed - Incl. @2.65 kV: Open x A,B,C; Closed: AB, BC, AC, AG, BG, CG
@1.80 kV: Accessories to Ground
@1.20kV: Motor connection to Ground

Primary Injection

Settings

Results

Acceptable Range

Test

ETU Initial settings / Test Current etc.; See Note 3 **A**

B

C

*

Min

Max

Long Tlme Pickup (A)	IR(xIn):	PU A:	tR(s):		
Long Time Delay (S)	Test Current:				
Short Time Pickup (A)	Isd (xIn):	PU A:	Tsd(s):		
Short Time Delay (S)	Tsd(s): Test Current:				
Instantaneous Pickup (A)	li (xIn):	PU A:			
Ground Fault Pickup (A)	Trip:	Alarm:	Tg(s):		
Neutral Delay (S)	tR(s):	IN (xIn): ON / IN = 0.5 x In			
	PU A:	Test Current:			

UVR Drop-out Voltage:

Notes:

1. This WL Low Voltage Power Circuit Breaker was tested in accordance with ANSI C37.50-1989
2. The above tests were carried out according to controlled Siemens-Ft. Worth test inspection plans and standards on calibrated equipment. This process and documentation is controlled and audited by UL in accordance with ISO9001:2008. Certification available upon request.
3. All delay test settings are the same as for the preceding pickup test unless otherwise noted. PU A = Function pickup setting in Amperes.
4. All WL Circuit Breaker ETUs are set to factory default safety settings prior to shipment.
[Lowest Pickups, Shortest Delays, N-protection off, Memory Off, GF=sumI]
5. The above product identification information [ETU, Catalog Number etc.] is accurate as of the test date. Any changes to this configuration are not covered by the above test results.
6. For product support, please contact your sales representative or customer service at: mark.vandre@siemens.com
7. DNT indicates 'Did Not Test' and represents a test not applicable to this configured breaker.

(signed)

Quality Manager, Siemens - Ft. Worth ModCenter

Source: Ft. Worth ModCenter Product Traceability System
Page: 1 of 1

SIEMENS
Ft. Worth

Date Printed:

6

WL POWER
CIRCUIT BREAKERS

WL Spare/Replacement Parts

Communication Components

Selection

Quick reference guide

Task	Accessories
Manual charging circuit breaker to electrically operated circuit breaker...	<ul style="list-style-type: none"> • WLELCMTRXX • WLMCOSW Motor Cut-off switch (Optional)
Remote operation of circuit breaker	<ul style="list-style-type: none"> • WLELCMTRXX • WLMCOSW Motor Cut-off switch (Optional) • Shunt Trip (WLSTXX) • Close coil (WLRCSXX) • Control Power
Remote operation of circuit breaker via communications	<ul style="list-style-type: none"> • WLELCMTRXX • WLMCOSW Motor Cut-off switch (Optional) • Shunt Trip (WLSTXX) • Close coil (WLRCSXX) • Com15/Com 16 (WLCMXX) • 24V DC Power Supply • Power supply for electric motor, shunt trip etc, should be separate than the one used for trip unit.
Dynamic Arc Sentry (DAS)	<ul style="list-style-type: none"> • WLDGNCUB (Digital Input Cubicle) • 24V DC Class 2 Power Supply
	Add the following to obtain tangible verification of the parameter switching
	<ul style="list-style-type: none"> • WLRLYCCUB (Configurable Relay output)
PROFIBUS Addition	Add the following for use with communications
	<ul style="list-style-type: none"> • WLCM15M for PROFIBUS • WLCM16MD for MODBUS
MODBUS Addition	To a circuit breaker:
	<ul style="list-style-type: none"> • WLCM15M + WLBSS • WLCM15RET includes (WLCM15M+WLBSS). This uses the 24VDC Class 2 power supply used for the ETU.
MODBUS Addition	To a switch:
	<ul style="list-style-type: none"> • WLCM15M + WLBSS + External 24VDC Class 2 UL Power Supply (WLSITOP25)
Power Supply Requirements	<p>For ETU, COMM and Cubicle bus modules, the power supply should be UL Listed Class 2 24VDC</p> <ul style="list-style-type: none"> • WLSITOP25 (2.5A) : good for 2 breakers (2ETUs, COMM Cubicle bus Modules) • WLSITOP1 (3.8A): good for up to 4 breakers (4ETUs, COMM Cubicle bus Modules)

WL Spare/Replacement Parts

Communication Components

Selection

Accessory	Description
WLELCMTRXX	<ul style="list-style-type: none"> Charging motor 24VDC/48VDC/125VDC/250VDC/120VAC/240VAC
WLMCOSW	<ul style="list-style-type: none"> Motor cut-off switch
WLSTXX	<ul style="list-style-type: none"> Shunt trip 3-cycle or continuous duty 24VDC/48VDC/125VDC/250VDC/120VAC/240VAC
WLRCSEX	<ul style="list-style-type: none"> Closing coil 3-cycle 24VDC/48VDC/125VDC/250VDC/120VAC/240VAC
WLBSS	<ul style="list-style-type: none"> Breaker Status Sensor (BSS Board)
WLSITOP25	<ul style="list-style-type: none"> Power supply for trip unit and communications 24VDC 2.5A SITOP Power, Class 2
WLSITOP1	<ul style="list-style-type: none"> Power supply for trip unit and communications 24VDC 3.8A SITOP Power, Class 2
WLCM15M	<ul style="list-style-type: none"> COM 15 PROFIBUS Communication Module
WLCM15RET	<ul style="list-style-type: none"> COM 15 PROFIBUS Communication Module with BSS
WLCM16MD	<ul style="list-style-type: none"> COM 16 MODBUS Communication Module
WLCM16RET	<ul style="list-style-type: none"> COM 16 MODBUS Communication Module with BSS

6

WL POWER
CIRCUIT BREAKERS

WL Power Circuit Breaker

Ratings for 4 Pole UL 1066 (ANSI C37) Listed Breakers

Selection

WL frame ratings – Frame size 2		800A			1600A		
Rating Class		S	H	L	S	H	L
Interrupting current frame I_{CS} (kAIR RMS) 50/60 Hz							
	254VAC	65	85	100	65	85	100
	508VAC	65	85	100	65	85	100
	635VAC	65	65	85	65	65	85
Short-time current I_{CW} (kA RMS)	1 sec.	65	65	85	65	65	85
Close and latch rating (kA RMS)		65	65	85	65	65	85
Applicable rating plug range		200 - 800A			200 - 1600A		
Minimum enclosure dimension (in.)		32Wx22.5Hx19.5D			32Wx22.5Hx19.5D		
Mechanical make-time (ms)		35			35		
Mechanical break-time (ms)		34			34		
Electric close make-time (ms)		50			50		
Electric trip/ UV break-time (ms)		40/73			40/73		
Electric trip and reclose interval (ms)		80			80		
Mechanical duty cycles (with maint.) ¹		15000			15000		
Electrical duty cycles (with maint.) ¹		15000			15000		
Draw-out breaker efficiency (Watts loss at rated I_N)		85			320		
Ambient operating temperature (°C)		-25 to 40			-25 to 40		
Weights (D.O. Breaker/Cradle/Fixed mount) lbs.		210/161/185			210/161/185		

WL frame ratings – Frame size 2		2000A			3200A		
Rating Class		S	H	L	S	H	L
Interrupting current frame I_{CS} (kAIR RMS) 50/60 Hz							
	254VAC	65	85	100	65	85	100
	508VAC	65	85	100	65	85	100
	635VAC	65	65	85	65	65	85
Short-time current I_{CW} (kA RMS)	1 sec.	65	65	85	65	65	85
Close and latch rating (kA RMS)		65	65	85	65	65	85
Applicable rating plug range		200 - 2000A			200 - 3200A		
Minimum enclosure dimension (in.)		32Wx22.5Hx19.5D			32Wx22.5Hx19.5D		
Mechanical make-time (ms)		35			35		
Mechanical break-time (ms)		34			34		
Electric close make-time (ms)		50			50		
Electric trip/ UV break-time (ms)		40/73			40/73		
Electric trip and reclose interval (ms)		80			80		
Mechanical duty cycles (with maint.) ¹		15000			15000		
Electrical duty cycles (with maint.) ¹		15000			15000		
Draw-out breaker efficiency (Watts loss at rated I_N)		700			1650		
Ambient operating temperature (°C)		-25 to 40			-25 to 40		
Weights (D.O. Breaker/Cradle/Fixed mount) lbs.		227/181/203			258/212/229		

¹ Maintenance means: replacing main contacts and arc chutes (see operating instructions).

WL Power Circuit Breaker

Ratings for 4 Pole UL 1066 (ANSI C37) Listed Breakers

Selection

WL frame ratings – Frame size 3		4000A	5000A
Rating Class		L	L
Interrupting current frame I_{CS} (kAIR RMS) 50/60 Hz	254VAC	100	100
	508VAC	100	100
	635VAC	85	85
Short-time current I_{CW} (kA RMS)	1 sec.	85	85
Close and latch rating (kA RMS)		85	85
Applicable rating plug range		800 - 4000A	800 - 5000A
Minimum enclosure dimension (in.)		42Wx22.5Hx19.5D	42Wx22.5Hx19.5D
Mechanical make-time (ms)		35	35
Mechanical break-time (ms)		34	34
Electric close make-time (ms)		50	50
Electric trip/UV break-time (ms)		40/73	40/73
Electric trip and reclose interval (ms)		80	80
Mechanical duty cycles (with maint.) ¹		10000	10000
Electrical duty cycles (with maint.) ¹		10000	10000
Draw-out breaker efficiency (Watts loss at rated I_n)		1100	1650
Ambient operating temperature (°C)		-25 to 40	-25 to 40
Weights (D.O. Breaker/Cradle/Fixed mount) lbs.		434/410/375	434/410/375

Ratings for UL 1066 Listed Non-automatic Switches

WL frame ratings		Frame size 2 800 - 3200A	Frame size 3 4000 - 5000A
Rating Class		L	L
Breaking capacity with external relay (kA RMS) 50/60 Hz, instantaneous trip	254VAC	100	100
	508VAC	100	100
	635VAC	85	85
Short-time current I_{CW} (kA RMS)	1 sec.	85	100 ²

¹ Maintenance means: replacing main contacts and arc chutes (see operating instructions).

² Do not apply switch or breaker rated at 635VAC to a system with fault current > 85kA RMS.

WL Power Circuit Breaker

UL 1066 Listed Catalogue Number

Selection

Rating plug			Breaker catalog number														
Maximum continuous Current rating (A)	Frame size 2	Frame size 3	1	2	3	4	5	6	7	8	9	10	11	12	13	14	15
200	X									A							
225	X									B							
250	X									C							
300	X									D							
315	X									E							
350	X									F							
400	X									G							
450	X									H							
500	X									J							
600	X									K							
630	X									L							
700	X									M							
800	X	X								N							
1000	X	X								P							
1200	X	X								Q							
1250	X	X								R							
1600	X	X								T							
2000	X	X								U							
2500	X	X								V							
3000	X	X								W							
3200	X	X								Y							
4000		X								Z							
5000		X								1							

Electronic trip units (ETU)

Trip unit type	Protective function			LCD display alpha num.	Ground fault module		
	L	S	I		Alarm	Trip	
ETU745	X	(X)	(X)				C
ETU745	X	(X)	(X)	X			D
ETU745	X	(X)	(X)		X		E
ETU745	X	(X)	(X)	X	X		F
ETU745	X	(X)	(X)		X	X	G
ETU745	X	(X)	(X)	X	X	X	H
ETU748	X	X					J
ETU748	X	X		X			K
ETU748	X	X			X		L
ETU748	X	X		X	X		N
ETU748	X	X			X	X	P
ETU748	X	X		X	X	X	Q
ETU776	X	(X)	(X)				V
ETU776	X	(X)	(X)		X		W
ETU776	X	(X)	(X)		X	X	Y

() Function can be disabled by user.

WL Power Circuit Breaker

UL 1066 Listed Catalogue Number

Selection

Bell alarm, breaker ready-to-close, auxiliary contacts						Breaker catalog number														
						1	2	3	4	5	6	7	8	9	10	11	12	13	14	15
Bell alarm		Form C Contacts	Breaker ready-to- close 1b contact	Breaker open/close auxiliary switches																
Remote reset coil voltage				2a + 2b	4a + 4b															
AC	DC																			
						None														
		X				X														
			X			A														
				X		B														
				X		C														
					X	D														
		X	X			E														
		X		X		F														
		X			X	G														
			X	X		H														
			X		X	I														
		X	X	X		J														
		X	X		X	K														
	24	X				L														
	48	X				M														
120	250	X				N														
240	250	X				O														
	24	X	X			P														
	48	X	X			Q														
120	125	X	X			R														
240	250	X	X			S														
	24	X		X		T														
	48	X		X		U														
120	125	X		X		V														
240	250	X		X		W														
	24	X			X	Y														
	48	X			X	Z														
120	125	X			X	1														
240	250	X			X	2														
	24	X	X	X		3														
	48	X	X	X		4														
120	125	X	X	X		5														
240	250	X	X	X		6														
	24	X	X		X	7														
	48	X	X		X	8														
120	125	X	X		X	9														
240	250	X	X		X															

Shunt trip

Control voltage		Status contact															
AC	DC																
			None														
	24		X														
	48		A														
			B														
120	125		C														
240	250		D														
	24	X	E														
	48	X	F														
120	125	X	G														
240	250	X	H														

WL Power Circuit Breaker

UL 1066 Listed Non-automatic Catalogue Number

Selection

Undervoltage release (with or without time delay) or 2nd shunt trip					Breaker catalog number															
					1	2	3	4	5	6	7	8	9	10	11	12	13	14	15	
Control voltage		UVR without delay	UVR with delay	UVR status contact 1	2nd shunt trip															
AC	DC																			
					None															X
	24	X																		A
	48	X																		B
120	125	X																		C
240	250	X																		D
	48		X																	E
120	125		X																	F
240	250		X																	G
	24				X															H
	48				X															J
120	125				X															K
240	250				X															L
	24	X		X																M
	48	X		X																N
120	125	X		X																P
240	250	X		X																Q
	48		X	X																R
	125		X	X																S
120	250		X	X																T

Charging motor, motor switch, operations counter

Charging motor operation voltage		Motor cut-off switch	Operations counter																	
AC	DC																			
				None																X
	24																			A
	48																			B
120	125																			C
240	250																			D
	24	X																		E
	48	X																		F
120	125	X																		G
240	250	X																		H
	24			X																J
	48			X																K
120	125			X																L
240	250			X																M
	24	X		X																N
	48	X		X																P
120	125	X		X																Q
240	250	X		X																R

¹ Status contact only available when communication is not installed. Signal is sent via communication in lieu of status contact.

WL Power Circuit Breaker

UL 1066 Listed Non-automatic Catalogue Number

Selection

Close coil, power metering and communications					Breaker catalog number										
					1	2	3	4	5	6	7	8	9	10	11
Close coil operation voltage		Power metering capable ¹	Modbus ²	PROFIBUS ²											
AC	DC														
					None										X
	24														A
	48														B
120	125														C
240	250														D
			X												G
				X											H
	24		X												N
	24			X											P
	48		X												S
	48			X											T
120	125		X												W
120	125			X											Y
240	250		X												2
240	250			X											3
	24	X	X												Q
	48	X	X												U
120	125	X	X												Z
240	250	X	X												4
	24	X		X											R
	48	X		X											V
120	125	X		X											1
240	250	X		X											5
		X	X												L
		X		X											M
		X													F
	24	X													6
	48	X													7
120	125	X													8
240	250	X													9

Breaker locks

Key lock breaker OPEN position (lock type – KIRK ³)	Key lock breaker OPEN position (lock type – SUPERIOR ³)	Padlock provisions for OPEN and CLOSE pushbuttons ⁴	Padlock provisions for charging handle											
				None										X
X														A
		X												C
			X											E
	X													F
X		X												G
	X	X												J
X			X											S
	X		X											U
		X	X											V
X		X	X											W
	X	X	X											Z

Miscellaneous options⁵

Key lock breaker OPEN position (provisions only) ⁴	Manual trip reset ETU (Automatic trip reset is standard)											
		None										N
X												w
	X											B
	X											C
X	X											D

1 Requires External PTs for voltage input and 24VDC power supply.

2 Includes BSS device and requires 24VDC power supply.

3 Custom key locks are not available and must be supplied by others. Order key lock provision if custom if keyed alike locks are required.

4 Locks provided by others.

5 If a breaker lock is chosen for Digit 14, a provision need not be ordered in Digit 15.

WL Power Circuit Breaker

UL 1066 Listed Non-automatic Catalogue Number

Selection

Breaking capacity, frame size, switch type and frame rating							Switch catalog number																				
Class	Interrupt rating (kA)		Frame Max. ampere rating (A)	Frame size		Fixed	Drawout	1	2	3	4	5	6	7	8	9	10	11	12	13	14	15					
	254VAC 508VAC	635VAC		2	3			↑	↑	↑	↑	↑	↑	↑	↑	↑	↑	↑	↑	↑	↑	↑	↑	↑			
L	100	85	800	X		X		L	2	J	4	0	8	S	S												
L	100	85	800	X			X	L	2	S	4	0	8	S	S												
L	100	85	1600	X		X		L	2	J	4	1	6	S	S												
L	100	85	1600	X			X	L	2	S	4	1	6	S	S												
L	100	85	2000	X		X		L	2	J	4	2	0	S	S												
L	100	85	2000	X			X	L	2	S	4	2	0	S	S												
L	100	85	3200	X		X		L	2	J	4	3	2	S	S												
L	100	85	3200	X			X	L	2	S	4	3	2	S	S												
L	100	85	4000		X	X		L	3	J	4	4	0	S	S												
L	100	85	4000		X		X	L	3	S	4	4	0	S	S												
L	100	85	5000		X	X		L	3	J	4	5	0	S	S												
L	100	85	5000		X		X	L	3	S	4	5	0	S	S												

WL Power Circuit Breaker

UL 1066 Listed Non-automatic Catalogue Number

Selection

Breaker ready-to-close auxiliary contacts			Switch catalog number																
			1	2	3	4	5	6	7	8	9	10	11	12	13	14	15		
Breaker ready-to-close	Breaker open/close auxiliary switches																		
1b contact	2a + 2b	4a + 4b	None									X							
X												B							
	X											C							
		X										D							
X	X											H							
X		X										I							

Shunt trip

Operation voltage		Status contact																	
AC	DC		1	2	3	4	5	6	7	8	9	10	11	12	13	14	15		
			None									X							
	24											A							
	48											B							
120	125											C							
240	250											D							
	24	X										E							
	48	X										F							
120	125	X										G							
240	250	X										H							

Undervoltage release (with or without time delay) or 2nd shunt trip

Operation voltage		UVR without delay	UVR with delay	UVR status contact ¹	2nd shunt trip																	
AC	DC					1	2	3	4	5	6	7	8	9	10	11	12	13	14	15		
						None									X							
	24	X													A							
	48	X													B							
120	125	X													C							
240	250	x													D							
	48		X												E							
120	125		X												F							
240	250		X												G							
	24				X										H							
	48				X										J							
120	125				X										K							
240	250				X										L							
	24	X		X											M							
	48	X		X											N							
120	125	X		X											P							
240	250	X		X											Q							
	48	X		X											R							
	125		X	X											S							
120	250		X	X											T							

¹ Status contact only available when communication is not installed. Signal is sent via communication in lieu of status contact.

WL Power Circuit Breaker

UL 1066 Listed Non-automatic Catalogue Number

Selection

Charging motor, motor switch, operations counter				Switch catalog number																
				1	2	3	4	5	6	7	8	9	10	11	12	13	14	15		
Charging motor operation voltage		Motor cutoff switch	Operations counter																	
AC	DC																			
				None											X					
	24														A					
	48														B					
120	125														C					
240	250														D					
	24	X													E					
	48	X													F					
120	125	X													G					
240	250	X													H					
	24		X												J					
	48		X												K					
120	125		X												L					
240	250		X												M					
	24	X	X												N					
	48	X	X												P					
120	125	X	X												Q					
240	250	X	X												R					

Close coil, communications

Charging motor operation voltage		Modbus 1	PROFIBUS 1																
AC	DC																		
				None											X				
		X													G				
	24														A				
	24	X													N				
	48														B				
	48	X													S				
120	125														C				
120	125	X													W				
240	250														D				
240	250	X													Z				
			X												H				
	24		X												P				
	48		X												T				
120	125		X												Y				
240	250		X												3				

¹ Requires 24VDC power supply. BSS is included.

WL Power Circuit Breaker

UL 1066 Listed Non-automatic Catalogue Number

Selection

Switch locks				Switch catalog number														
				1	2	3	4	5	6	7	8	9	10	11	12	13	14	15
Key lock breaker OPEN position (lock type – KIRK) ¹	Key lock breaker OPEN position (lock type – SUPERIOR) ¹	Padlock provisions for OPEN and CLOSE pushbuttons ²	Padlock provisions for charging handle	None													X	
X																		A
		X																C
			X															E
	X																	F
X		X																G
	X	X																J
X			X															S
	X		X															U
		X	X															V
X		X	X															W
	X	X	X															Z
Miscellaneous options ³																		
Key lock breaker OPEN position (provision only) ²				None													N	
X																	B	

UL 1066 Fixed Mount breaker vertical connector kits

6
WL POWER
CIRCUIT BREAKERS

Description	Catalog Number
FS 2 800A - 1600A Rear Vertical Connectors (8 pieces, includes Neutral Pole)	WL4L2R16CONUL
FS 2 2000A Rear Vertical Connectors (8 pieces, includes Neutral Pole)	WL4L2R20CONUL
FS 2 3200A Rear Vertical Connectors (8 pieces, includes Neutral Pole)	WL4L2R32CONUL ⁴
FS 3 4000A - 5000A Rear Vertical Connectors (8 pieces, includes Neutral Pole)	WL4L3R50CONUL ⁴

¹ Custom key locks are not available and must be supplied by others. Order Key Lock Provisions if custom keys or keyed alike breakers are required.

² Lock provided by others.

³ If a breaker lock is chosen for Digit 14, a provision need not be ordered in Digit 15.

⁴ FS II 3200A, FS III 4000A, 5000A breakers include vertical connectors as a standard.

WL Power Circuit Breaker

UL 1066 Listed Non-automatic Catalogue Number

Selection

Interrupting rating, frame size and frame rating					Cradle catalog number																
Class	Interrupt rating (kA)		Frame Max. ampere rating (A)	Frame size		G	2	3	4	5	6	7	8	9	10	11	12	13	14	15	
	240VAC 480VAC	600VAC		2	3																
S	65	65	800	X		S	2	4	0	8											
S	65	65	1600	X		S	2	4	1	6											
S	65	65	2000	X		S	2	4	2	0											
S	65	65	3200	X		S	2	4	3	2											
H	85	65	800	X		H	2	4	0	8											
H	85	65	1600	X		H	2	4	1	6											
H	85	65	2000	X		H	2	4	2	0											
H	85	65	3200	X		H	2	4	3	2											
L	100	85	800	X		L	2	4	0	8											
L	100	85	1600	X		L	2	4	1	6											
L	100	85	2000	X		L	2	4	2	0											
L	100	85	3200	X		L	2	4	3	2											
L	100	85	4000		X	L	3	4	4	0											
L	100	85	5000		X	L	3	4	5	0											

Type of secondary terminal connection ¹		
For breakers:		
Screw clamp terminals		P
Spring clamp terminals		T
Ring terminals		R
Spring clamp terminals (low profile, non-partable design)		K
For switch (non-automatic)		
Screw clamp terminals		D
Spring clamp terminals		E
Ring terminals		F
Screw clamp terminals, non-partable design)		M
Truck Operated Contacts (TOC)		
Breaker position switches in the following configurations:		
None		X
(1) Connected, (1) Test, (1) Disconnected – all Form C		1
(3) Connected, (2) Test, (1) Disconnected – all Form C		3
(6) Connected – all form C		6
Cradle mounted key locks		
None		X
Lock breaker in OPEN position (Kirk key)		A
Lock breaker in OPEN position (Superior key)		B
Double lock breaker in OPEN position (Kirk key)		C
Double lock breaker in OPEN position (Superior key)		D
Provision only – Lock breaker in OPEN position		E
Provision only – Double lock breaker in OPEN position		F
Primary conductor isolation shutter		
None		X
Isolation shutters		F

¹ Terminal blocks (X5, X6, X8, X9) are installed as standard.

WL Power Circuit Breaker

UL 1066 Listed Catalog Number

Selection

			Cradle catalog number														
			G	2	3	4	5	6	7	8	9	10	11	12	13	14	15
Arc chute cover																	
None													X				
Arc chute covers													A				
Arc chute covers													B				
Door locks and mechanical																	
1. Mechanical interlock with 2.0 meter Bowden cable 2. Locks cubicle door, when breaker is in connect position 3. Locks against racking breaker if the cubicle door is open																	
1	2	3															
																	X
X																	M
	X																A
		X															C
X	X																D
X	X	X															E
X		X															G
	X	X															H
Mechanism Operated Contacts (MOC)																	
Breaker open/close auxiliary switches (4a & 4b) in the following positions:																	
None																	X
Test and Connect position (FS2 only)																	M
Connect position (FS2 only)																	N
Test and Connect position (FS3 only)																	P
Connect position (FS3 only)																	Q
Connector and heater options																	
Standard read connectors																	X
Standard rear connectors and a cradle heater																	H
Rotatable rear connectors (FS2, 2000A and below & H Class)																	J
Rotatable rear connectors and a cradle heater (FS2, 2000A and below & H Class)																	K
Future use																	
Placeholder (required)																	N

UL 1066 Listed cradle accessories

Cradle accessories	Catalog Number
WL FS2 SHUTTER, 4-Pole	WL4SHUT2L
WL FS3 SHUTTER, 4-Pole	WL4SHUT3L
WL FS2 Cradle Arc Chute Cover 4-Pole	WL4GARC2
WL FS3 Cradle Arc Chute Cover 4-Pole	WL4GARC3
WL Cradle Lock Single Kirk FS2 4-Pole	WL4DLKRRK2
WL Cradle Lock Single Superior FS2 4-Pole	WL4DLSUP2
WL Cradle Lock Double Kirk FS2 4-Pole	WL4DLDKRRK2
WL Cradle Lock Double Superior FS2 4-Pole	WL4DLDSUP2
WL Cradle Lock Single Provision FS2 4-Pole	WL4DLPR2
WL Cradle Lock Single Kirk FS3 4-Pole	WL4DLKRRK3
WL Cradle Lock Single Superior FS3 4-Pole	WL4DLSUP3
WL Cradle Lock Double Kirk FS3 4-Pole	WL4DLDKRRK3
WL Cradle Lock Double Superior FS3 4-Pole	WL4DLDSUP3
WL Cradle Lock Single Provision FS3 4-Pole	WL4DLPR3

WL Power Circuit Breaker Cradles

UL 1066 Listed Non-automatic Catalogue Number

Selection

Frame Size II, Drawout (3-Pole and 4-Pole)

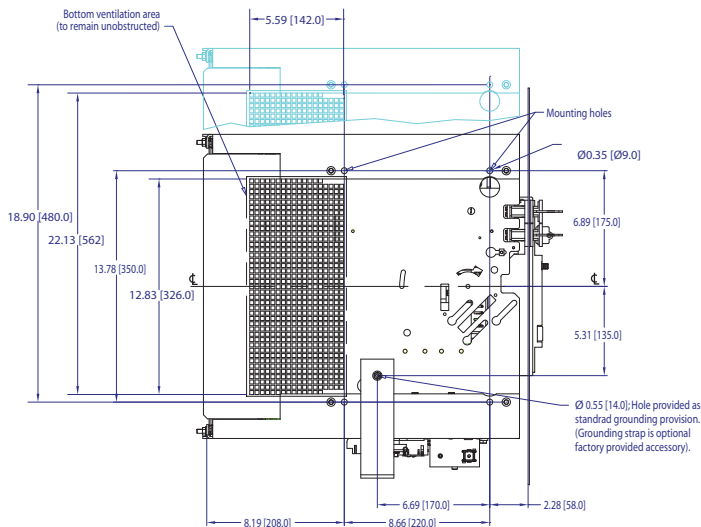
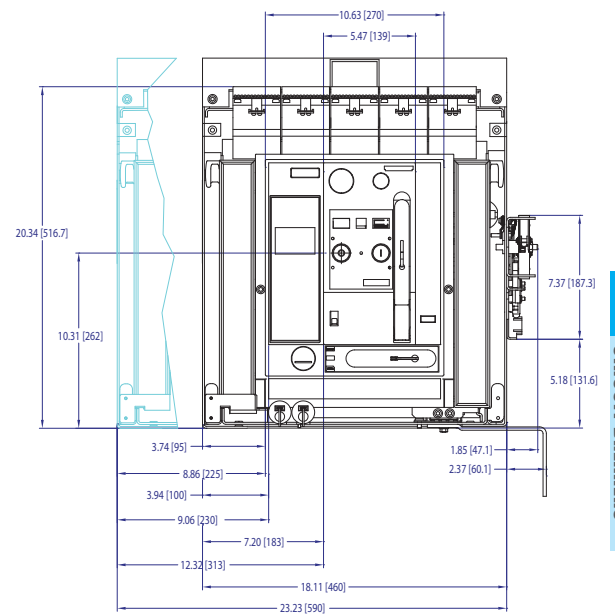
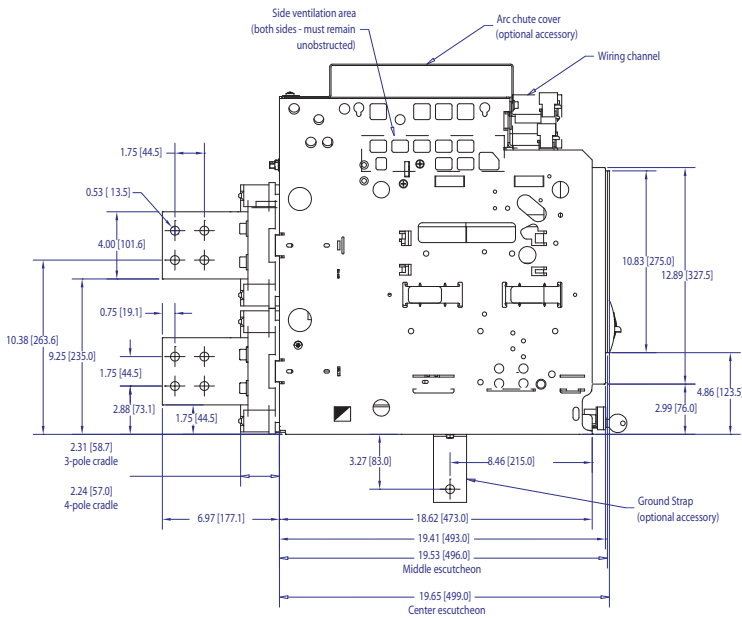
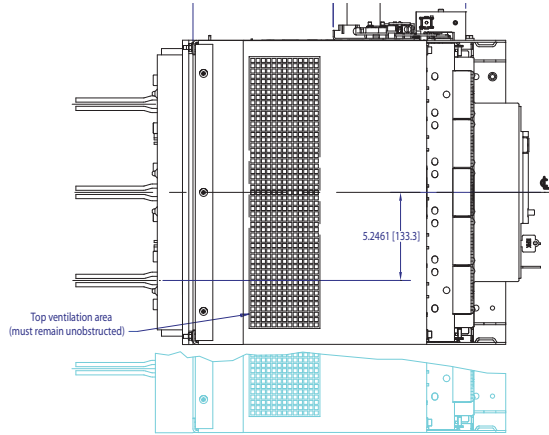

6
WL POWER
CIRCUIT BREAKERS

WL Power Circuit Breaker Cradles

Frame Sizes / Drawings

Selection

3200 A

2000 A

800/1600 A

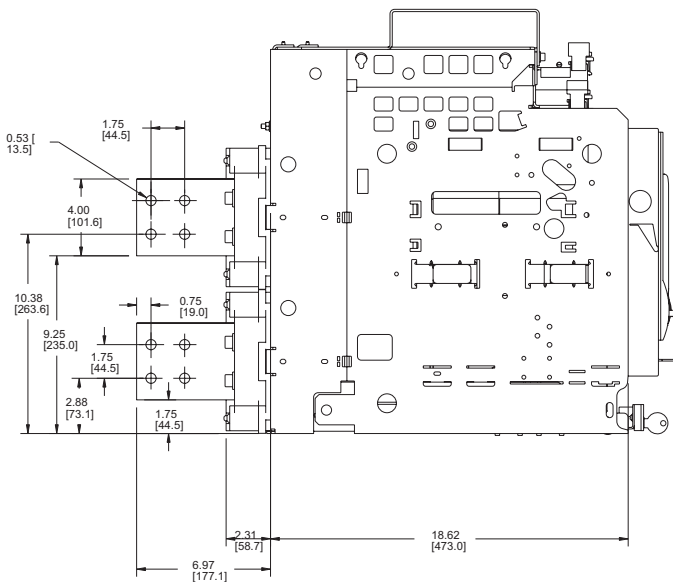
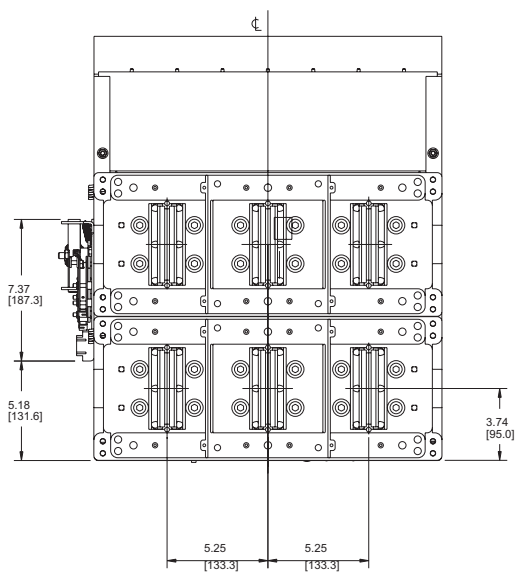
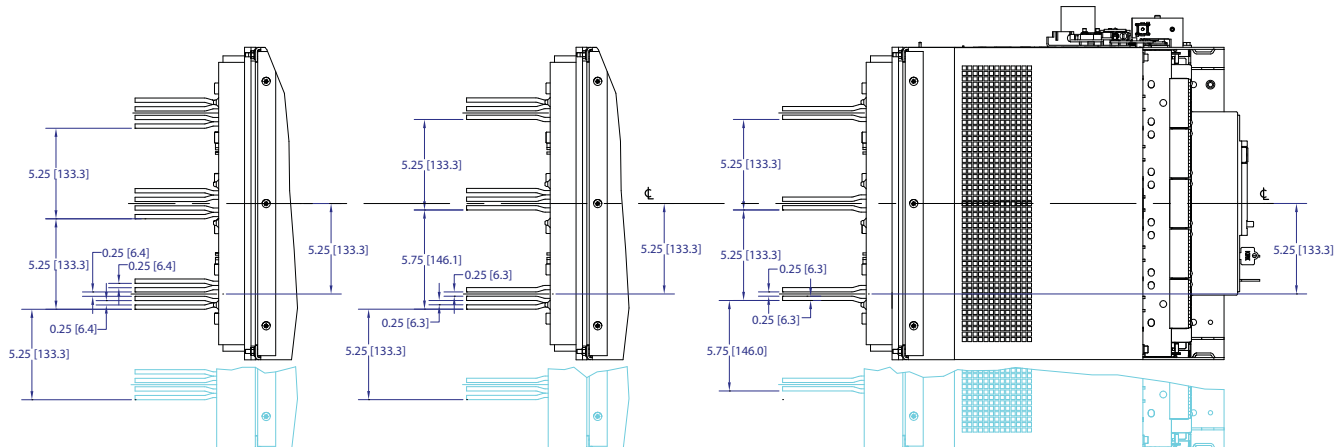

WL Power Circuit Breaker Cradles

Frame Sizes / Drawings

Selection

HORIZONTAL MAIN
BUS CONNECTORS

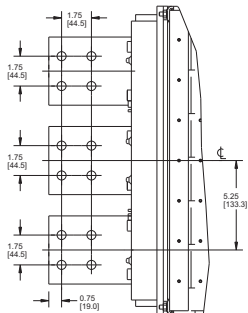

VERTICAL MAIN
BUS CONNECTORS

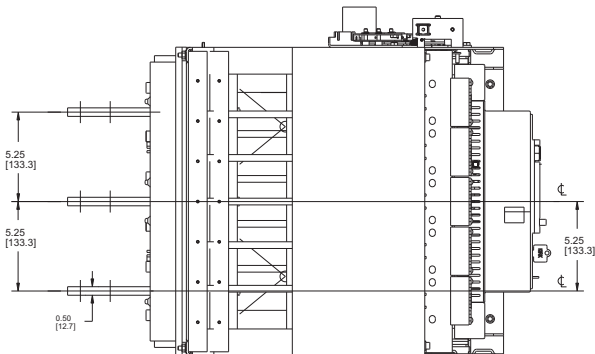

HORIZONTAL MAIN
BUS CONNECTORS

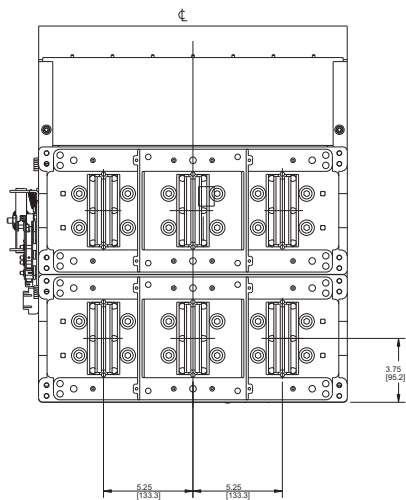

VERTICAL MAIN
BUS CONNECTORS

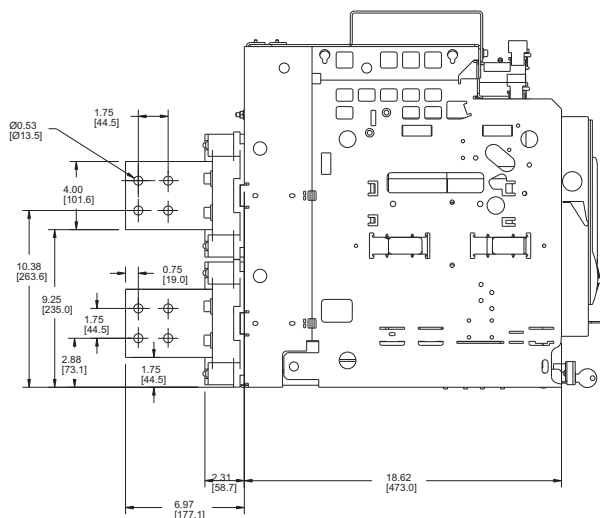
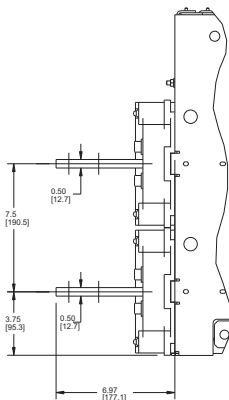

NOTE:

ROTATABLE MAIN BUS CONNECTORS ARE ONLY AVAILABLE UNDER THE FOLLOWING CONDITIONS:

- (1) ONLY ACCEPTABLE FOR 3-POLE VERSIONS
- (2) ONLY ACCEPTABLE FOR FS2 800A-2000A
- (3) ONLY ACCEPTABLE FOR SHORT-CIRCUIT RATINGS OF 85KAIC OR LESS

WL Power Circuit Breaker Cradles

Frame Sizes / Drawings

Selection

Lifting Point (Cradle only) Do not lift by other points.

Lifting Point (Cradle and Breaker) Do not lift by other points.

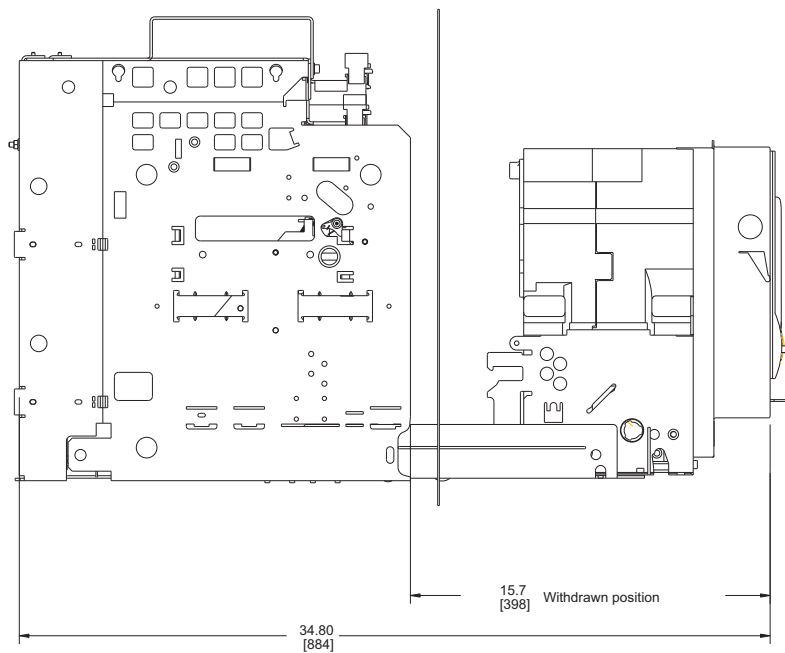
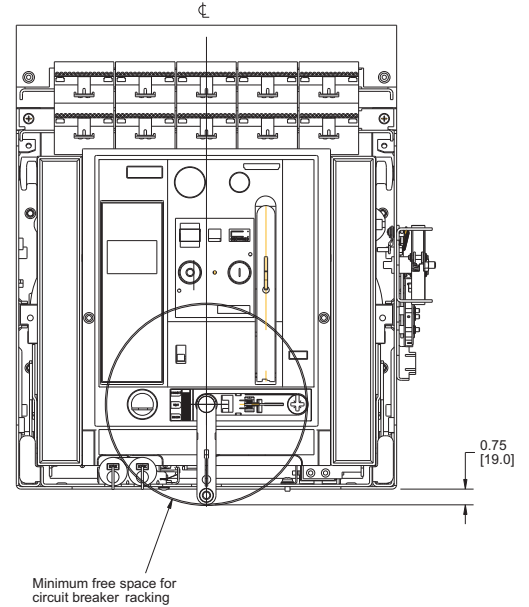
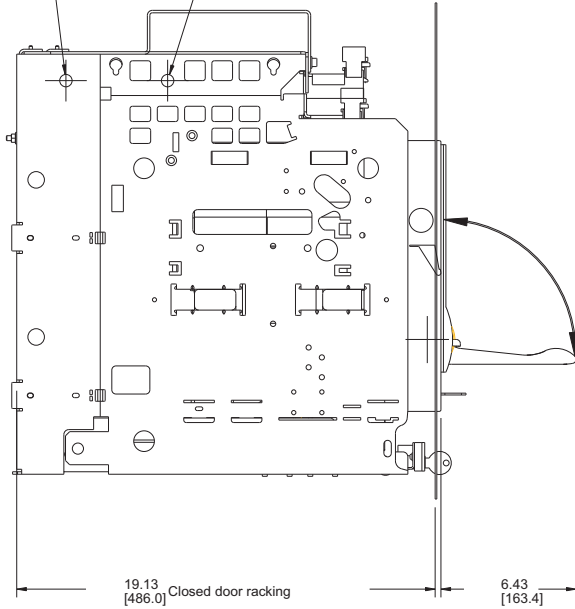

6

WL POWER
CIRCUIT BREAKERS

WL Power Circuit Breaker Cradles

Frame Sizes / Drawings

Selection

Frame size II, fixed-mounted version

Fixed mount versions are only available with rear vertical connector for FS2 3200A and FS3 4000A/5000A

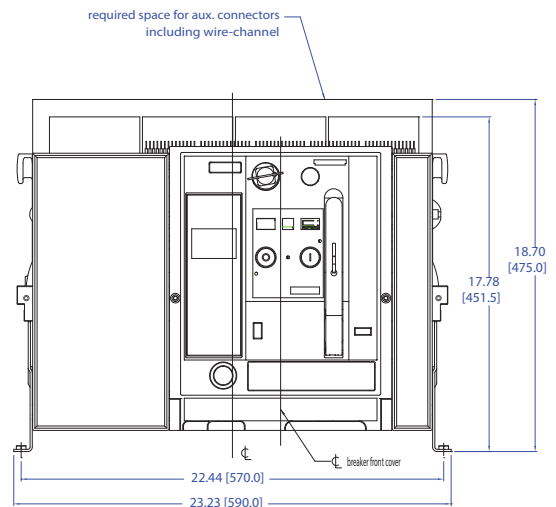
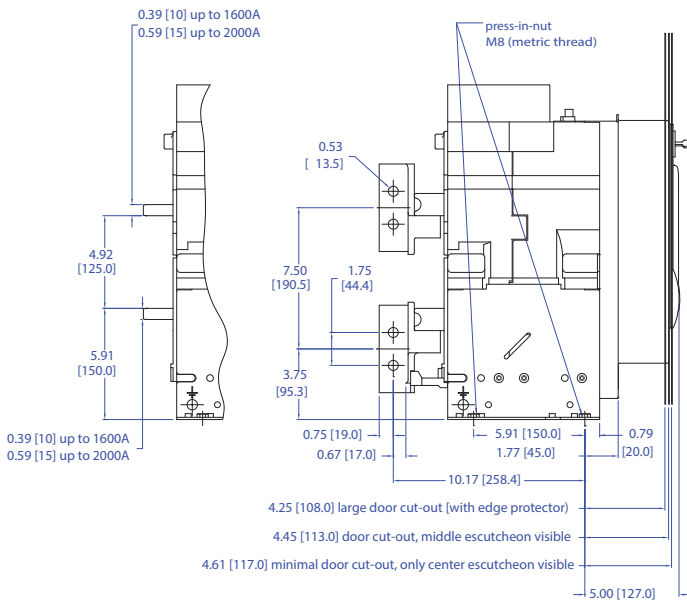
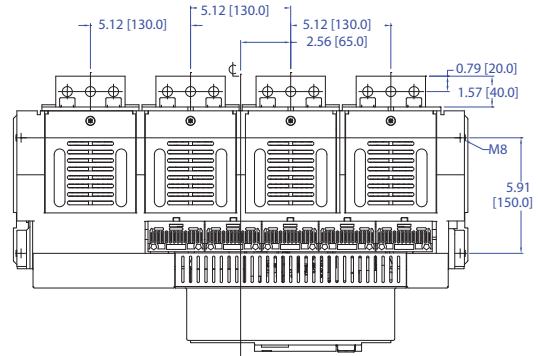

Rear View

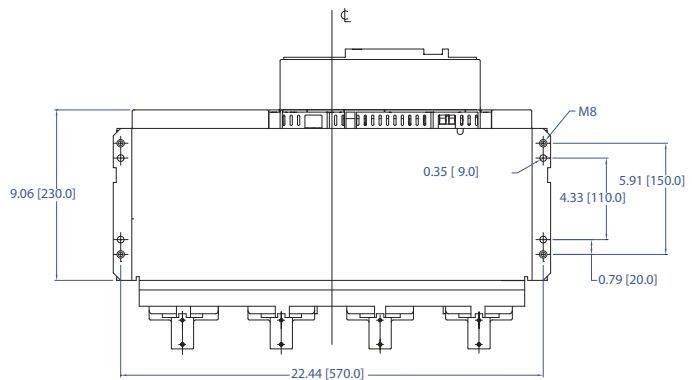
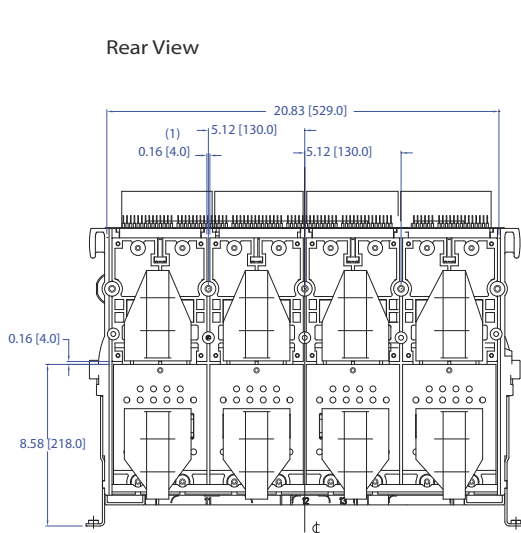

(1) = Slots 0.2 [5] for insulation barriers

WL Power Circuit Breaker Cradles

Frame Sizes / Drawings

Selection

Frame size III, fixed-mounted version

Fixed-mounted versions are only available as 4-pole with vertical connections.

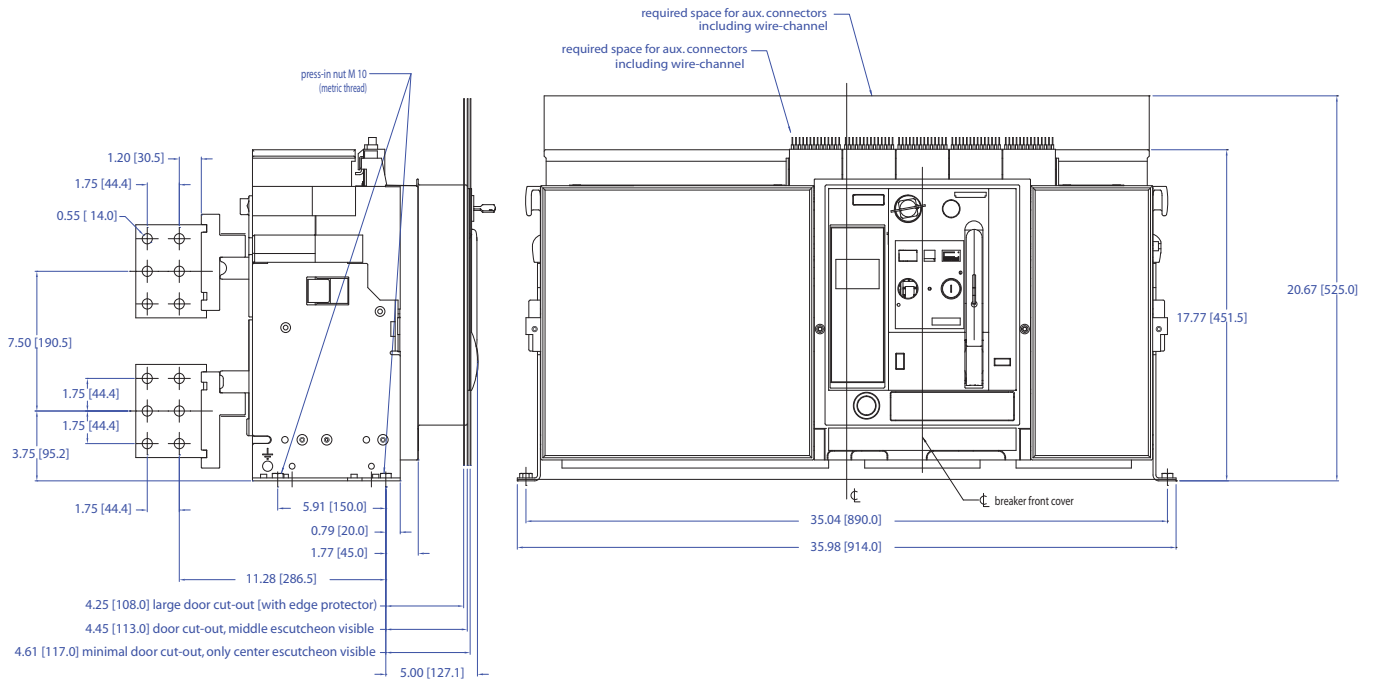

Top view vertical connection

Rear view

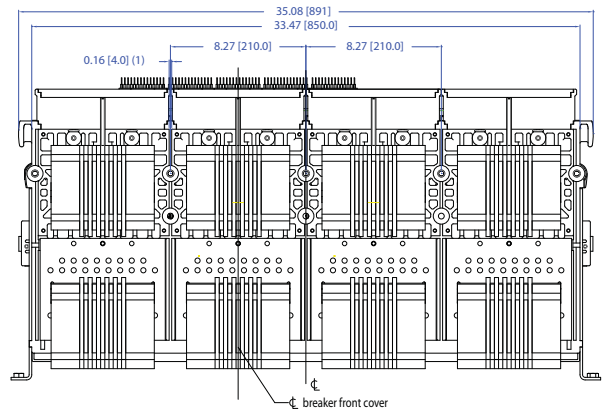
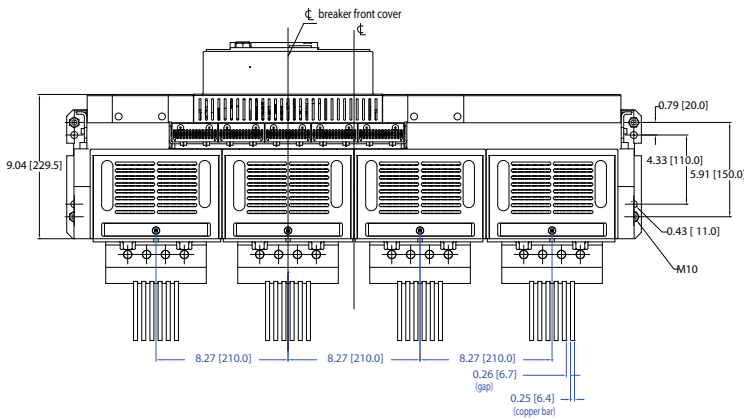

WL Power Circuit Breaker Cradles

Frame Sizes / Drawings

Selection

Frame size III, Drawout (3-Pole and 4-Pole)

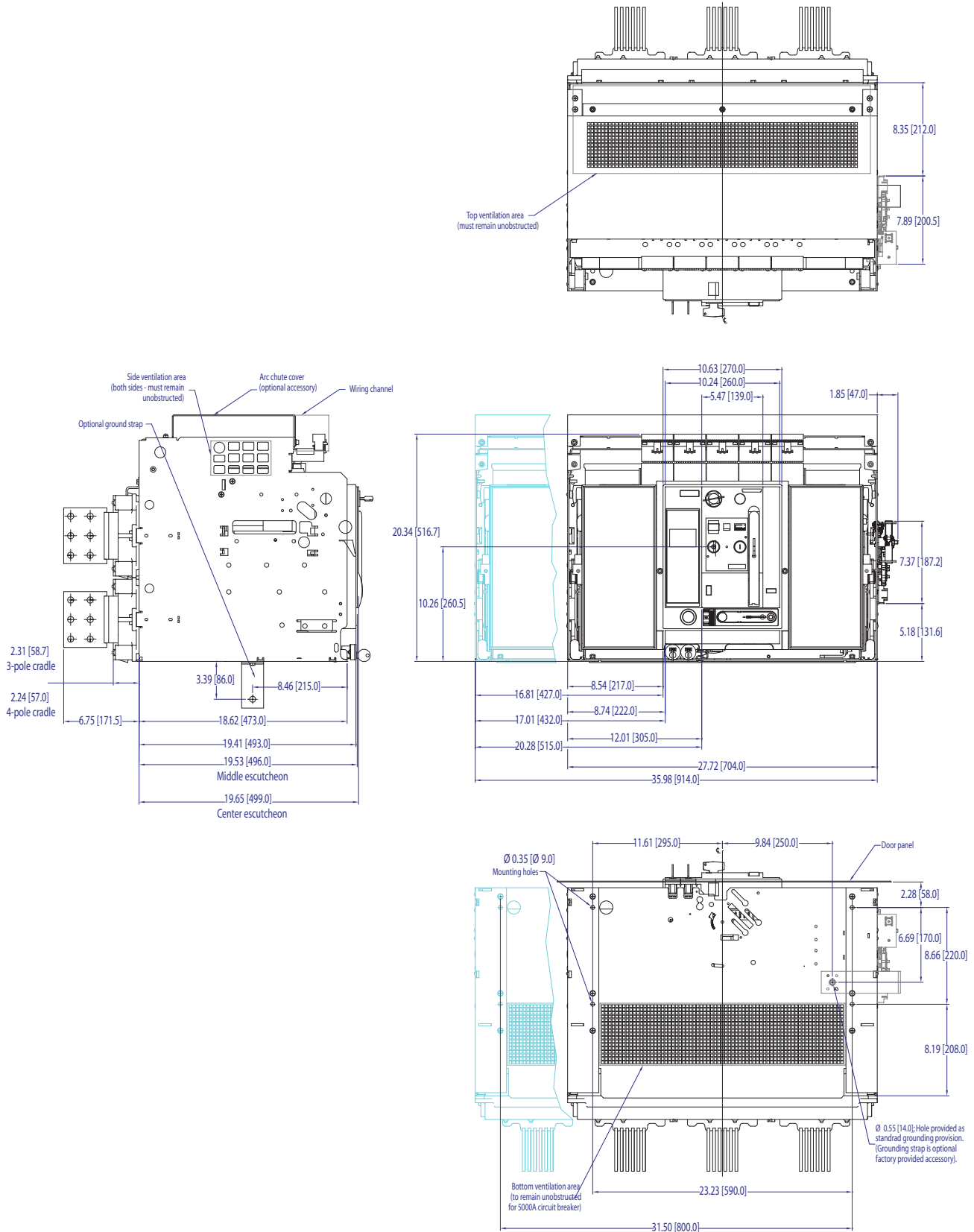

WL Power Circuit Breaker Cradles

Frame Sizes / Drawings

Selection

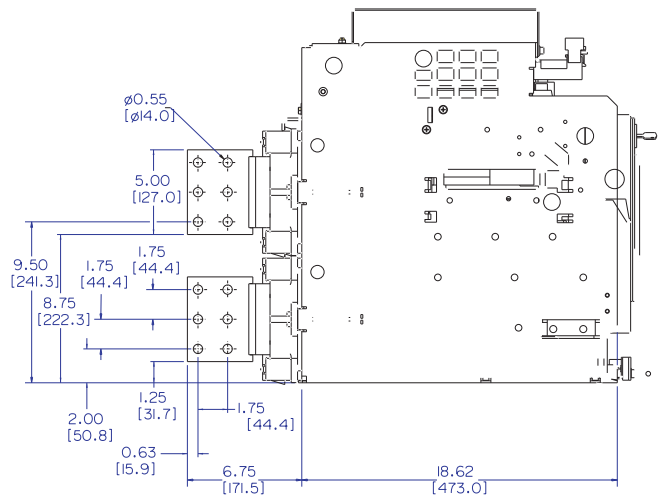
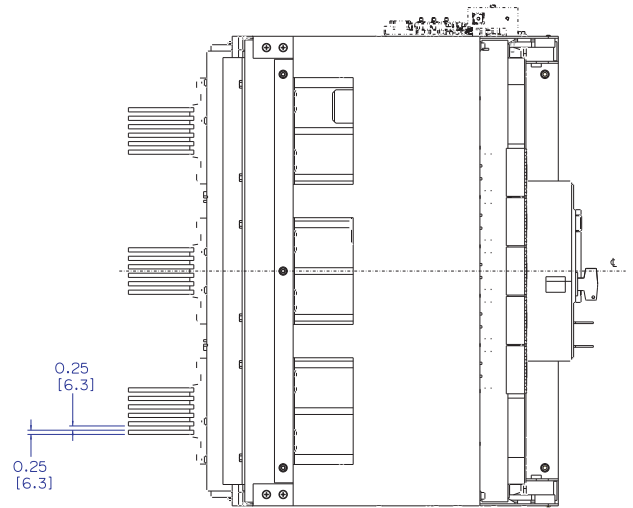
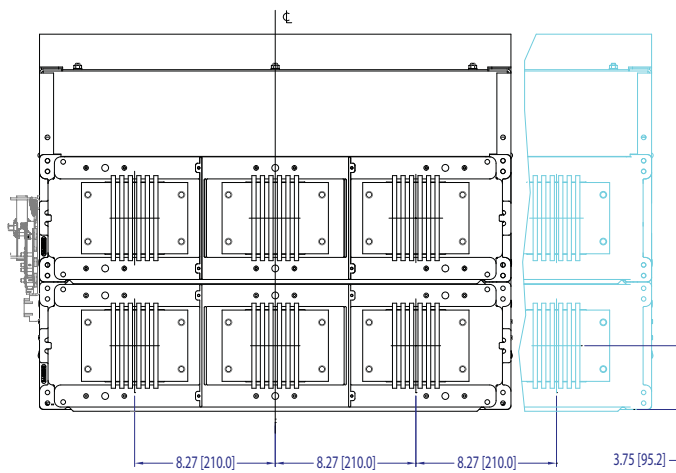

WL Power Circuit Breaker Cradles

Frame Sizes / Drawings

Selection

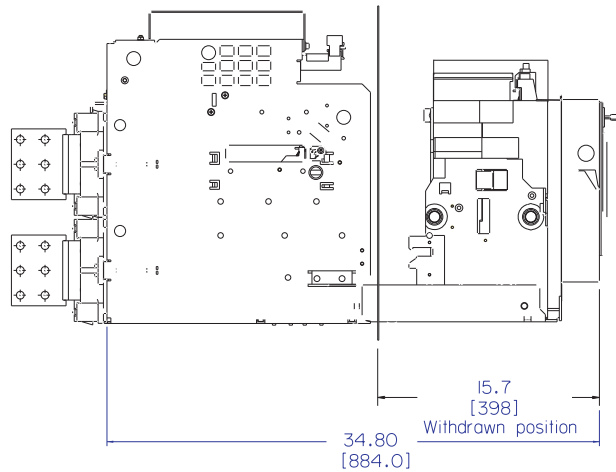
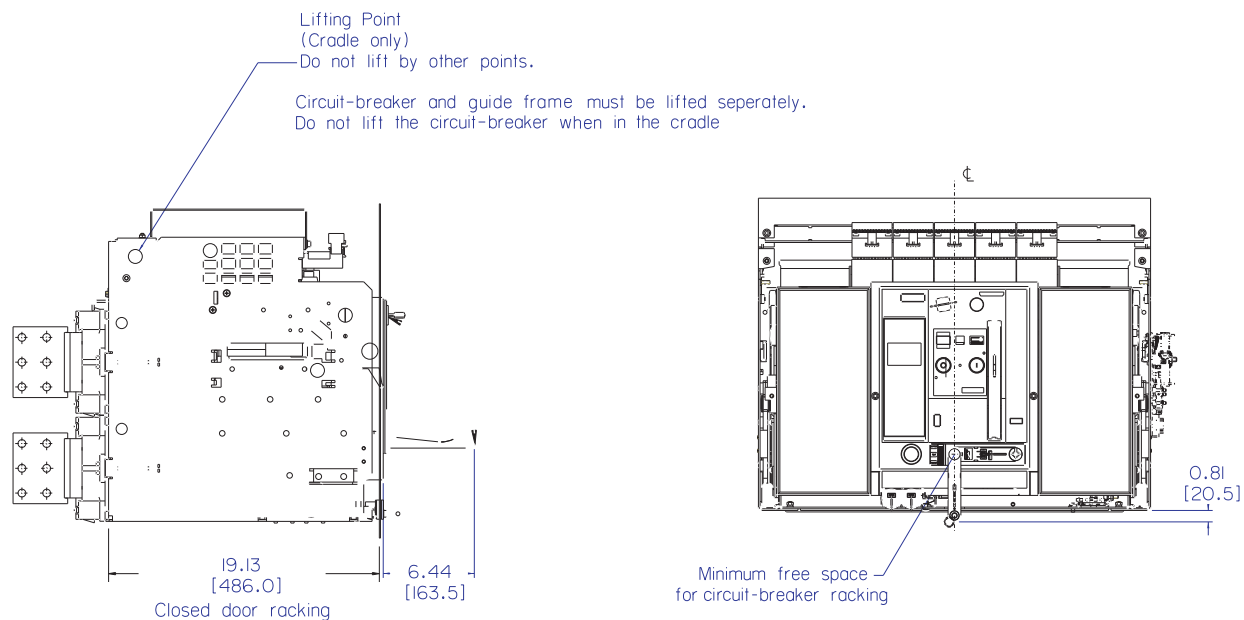

6

WL POWER
CIRCUIT BREAKERS

Notes

6

W1 POWER
CIRCUIT BREAKERS