

Enhanced reverse interlocking for busbars with multiple in-feeds

Objective

By means of the directional comparison signals provided by the over-current relays in the SIPROTEC 4 protection product range a scheme for busbar protection must be constructed that also functions when there are multiple in-feeds to the busbar.

How is the standard reverse interlocking arrangement designed?

The conventional reverse interlocking application will initially be described:

Several consumers are supplied from a busbar via feeders. The over-current protection relays are applied on the feeders with time graded settings. The greater the number of devices applied in the grading scheme, the longer the tripping time will be at the busbar. If for example 3 protection devices are time graded along one feeder with a grading time of 300 ms in each relay, then a tripping time of almost 1 sec is already reached at the busbar. In general, it should be avoided that short circuit currents are present for longer than 1 sec.

A further protection device towards the in-feed would have to be applied with an additional grading step and therefore has an additional 300 ms delay for the tripping time, i.e. a fault on the busbar which is only detected by the protection device on the in-feed has a total tripping time equal to the longest set time on the outgoing feeders plus a further 300 ms grading time.

This very long tripping time has to be avoided. For this purpose, the reverse interlocking scheme is conceived.

See Figure 1:

From the busbar the protection devices on the feeders have set tripping times of 300 and 600 ms, i.e. there are further protection devices applied along the feeder towards the consumer.

The protection relay on the in-feed has two definite time over-current stages I> and I>>. The setting is the same, the tripping times however differ substantially. T I> for example is set to 900 ms tripping time, while T I >> is set to only 50ms. The 50ms stage can be blocked via binary input.

A differentiation between faults on a feeder and on the busbar must be achieved. In the event of a fault on a feeder, the protection device in the feeder and in the in-feed will pick up. By means of the over-current pick-up signal of the device in the feeder, the I>> stage in the device applied to the in-feed, that has a time delay of 50 ms is blocked via external wiring and a binary input.

As soon as a fault on the busbar arises, none of the devices on the feeders will pick up and therefore there will be no blocking signal of the I>> stage in the in-feed. The I>> stage in the in-feed with a time delay of 50 ms is therefore active and trips with this short time delay, thereby circumventing the very long grading time that would have applied. The grading time of T I > 900 ms does not have to expire.

This concept may be applied as long as there is only one in-feed to the busbar.

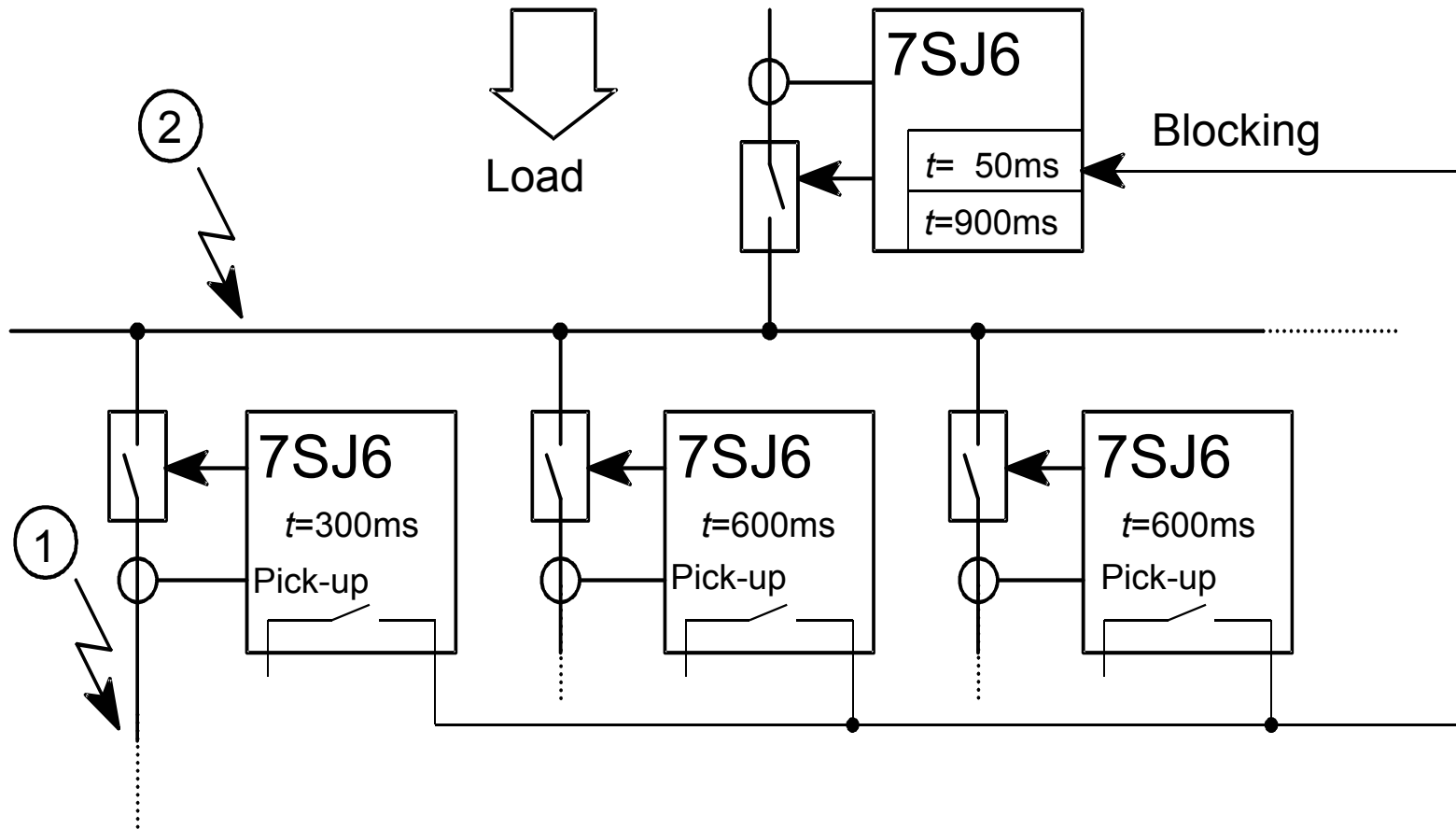

- ① Fault on the feeder. The protection relay closest to the fault picks up and trips along with blocking the device at the in-feed.
- ② Fault on the busbar. None of the protection devices in the feeders pick up and therefore no blocking signal is generated to the device at the in-feed. The in-feed protection relay trips with the short time delay of 50ms with the I >> stage.

Figure 1 Conventional reverse interlocking

What exactly is the enhanced reverse interlocking ?

In the event of multiple in-feeds to the busbar, the concept described above can no longer be used. The protection devices in this event can no longer make a clear distinction between the conditions “fault on the feeder” and “fault on the busbar”.

In this situation the directional elements of the over-current protection functions are applied. By the combination of directional and non-directional stages, the busbar fault can be uniquely identified.

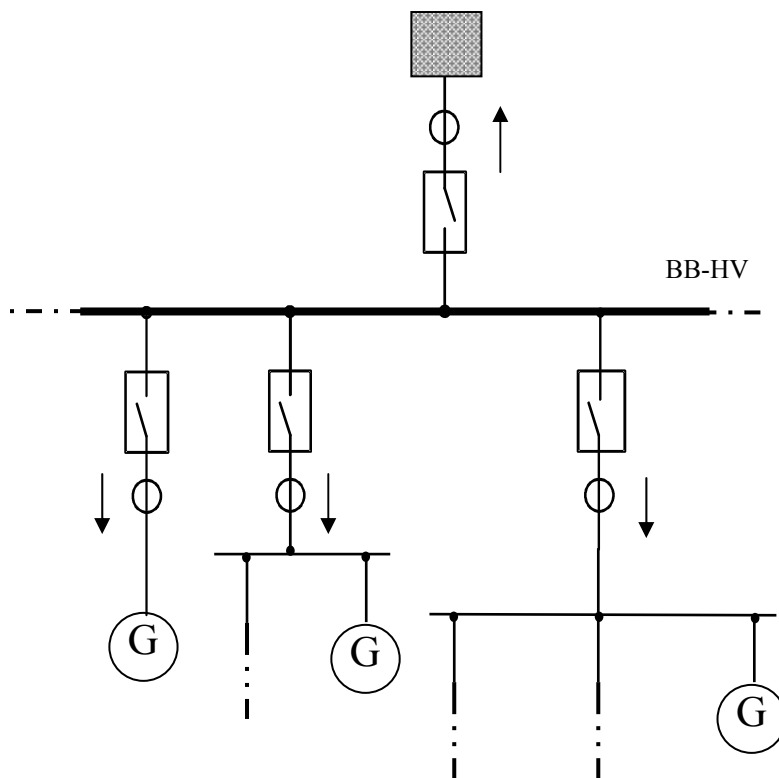

Figure 2: Example of multiple in-feeds to the busbar (on BB-HV), protection device with directional measurement

Solution:

1. All devices must be set so that their „**Forward Direction**“ is away from the busbar.
2. The busbar is protected by the **non-directional I>>** and **Ie>>** stages (busbar protection). The pick-up threshold of these stages must be set such that they securely detect all short circuits on the busbar. They operate with a time delay of approx. 80-100ms.
3. If, in the event of a fault, any one of the protection devices picks up with the **directional I>** or **IE>** stage in the “forward” direction, then the fault cannot be on the busbar. In this event, the non-directional **I>>** and **Ie>>** stages in all devices must be blocked.
4. For this purpose the following signals must be allocated to a binary output in each of the protection devices
 - a) 2692 directional pick-up definite time/inverse time Phase L1
 - b) 2693 directional pick-up definite time/inverse time Phase L2
 - c) 2694 directional pick-up definite time/inverse time Phase L3
 - d) 2695 directional pick-up definite time/inverse time earth

The contacts of all devices must be connected in parallel.

5. In addition a binary input on each device must be allocated with the following two signals
 - a) 1721 > definite time/inverse time **I>>** blk
 - b) 1724 > definite time/inverse time **IE>>** blk

This input must then be connected to the above outputs.

6. The directional stages **I>** and **IE>** are used to generate the blocking signals and must therefore have a current pick-up threshold that is equal to or lower than the setting for the non-directional stages **I>>** and **IE>>**. The time delay setting may be large.
7. For the normal time graded protection, the directional stages **I>>**, **IE>>**, **I_p** and **IE_p** in the forward direction are used.
8. The non-directional stages **I_p** and **IE_p** may be used as back-up for “reverse” faults, if the set delay times are greater than those applied for the stages under point 7 above.
9. The non-directional stages **I>** and **IE>** are not used in this context.