

SIEMENS

F1 10" Deep FPP F672 Twin 200A Vacu-Break Mounting Kit

Installation
Instructions

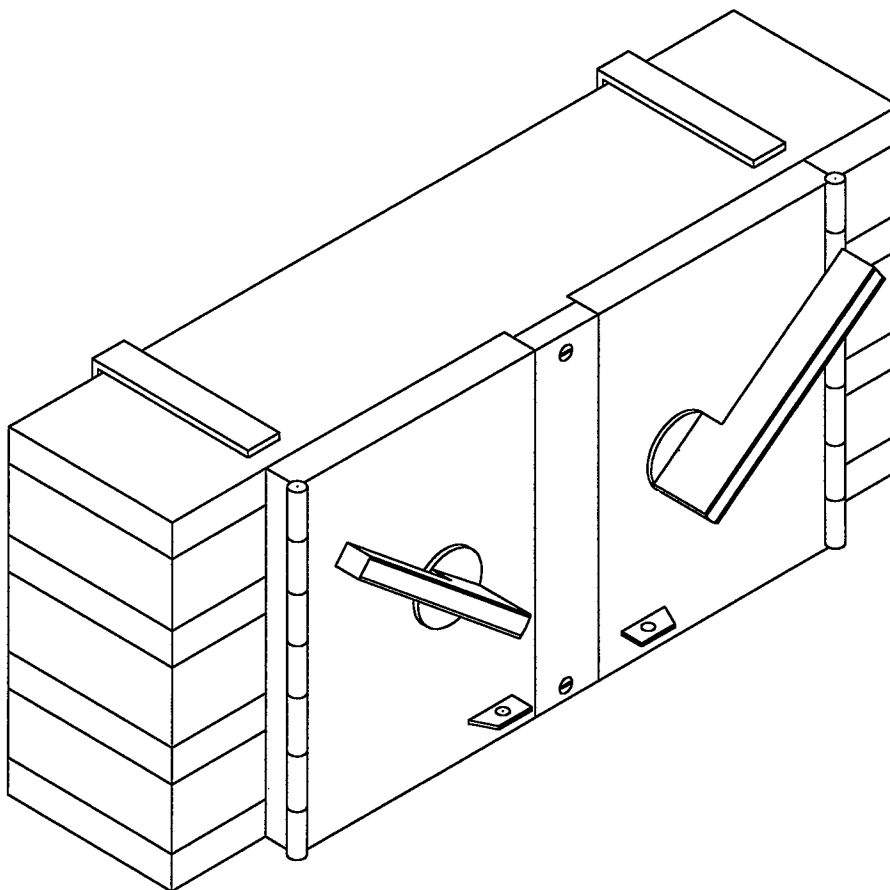

Installation Instructions

The following instructions are for the installation of a Siemens Twin 200A Vacu-Break in a type F1 and 10" FPP power panelboard. This device will require 10" of unit space. The parts provided in this kit are for connections to a 3 phase 3 wire or 4 wire system. For 3 phase 3 wire discard neutral lug and hardware (fig.9).



⚠ DANGER

High voltage.
Will cause severe injury or death.
Qualified personnel only.
Lock off power supplying this equipment before working inside.

- Remove the Vacu-Break kit from the shipping box and check the hardware against the following list.

HARDWARE LIST

ITEM	DESCRIPTION	QTY.
1	200A TWIN VACU BREAK	
* 2	1/4-20 X 1/2 SLOTTED TRUSS SCREW	2
* 3	1/4" SPACER	2
* 4	1/4-20 X 1.00 SLOTTED HEX WASHER HEAD SCREW	2
5	MOUNTING HARDWARE KIT	1
6	350 KCMIL LUG	2
7	1/4-20 X 1/2 HEX HEAD MACH. SCREW	4
8	1/4 LOCK WASHER	4
9	1/4 FLAT WASHER	4

* ITEMS COME WITH THE SWITCH

- Reference fig. (4 & 5) - The first items to be installed are 1/4-20 x 1/2" truss screw (item 2) and spacer (item 3). Locate the Z-rails on both sides of the vertical bus. Find the first 7/32" diameter hole on the Z-rail, 5/8" down from the top of the 10" unit space. Insert item 2 through item 3 then into the 7/32" diameter hole and tighten (items 2 and 3 form a mounting stud).

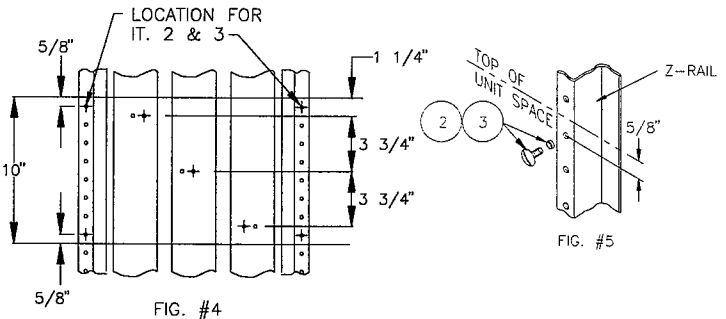
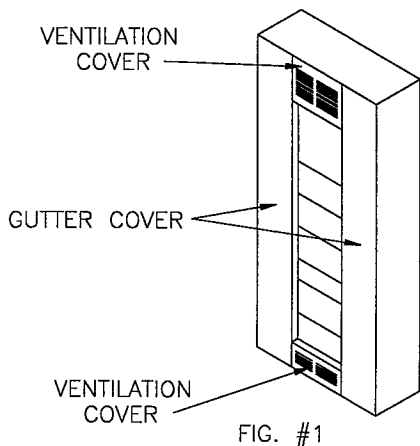

- Reference fig. (2) - To mount this switch in the panelboard, 10" of empty unit space is required. To locate the mounting position, measure from the top of the dead front support to the top of the empty unit space filler on the dead front. Transfer this dimension from the top of the dead front support along the Z-rail and mark. This will be the unit line as shown on (fig. 5).

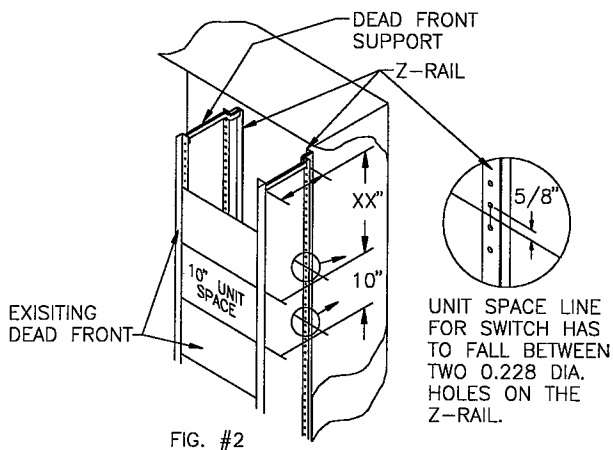

- Reference fig. (6) - Located on back side of the switch are two support brackets. Each bracket has a 1/4" diameter hole and 3/8" open end slot. The open end slot is located near the the top side of the switch. Line up the open end slots to the right side of the mounting stud located on the Z-rail. Then slide the switch to the left onto the mounting post . This will give the switch temporary support.

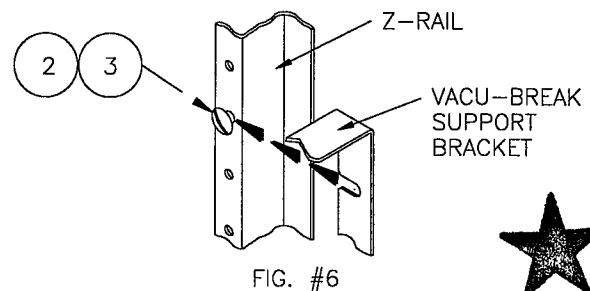

7. Reference fig. (7) - Open both fuse compartment doors to locate the through holes for 1/4-20 x 1" thread forming screw (item 4). The through holes are inside, near the bottom left and bottom right corners of the switch. Insert the hardware into the through holes that line up with 7/32" diameter holes in the Z-rail then tighten. This will give the switch total support

TO OPEN THE DOOR THE HANDLE MUST BE IN THE DOWN POSITION THEN SLIDE LOCK HASP LEFT OR RIGHT PULL ON HANDLE

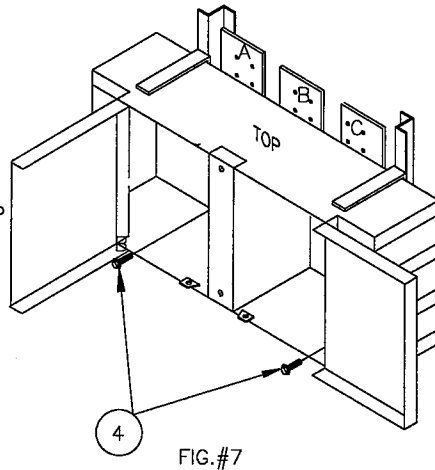

FIG.#7

9. Reference fig. (9) - On 3 phase 4 wire system the Vacu-Break assembly kit will also require a neutral lug connection to the branch neutral located near the top or the bottom of the Z-rail. Locate the "Z" shaped connector on the branch neutral and attach 350 kcmil lug (item 6) using 1/4-20 x 1/2" mach. screw (item 7) with 1/4" lock washer (item 8) and 1/4" flat washer (item 9).

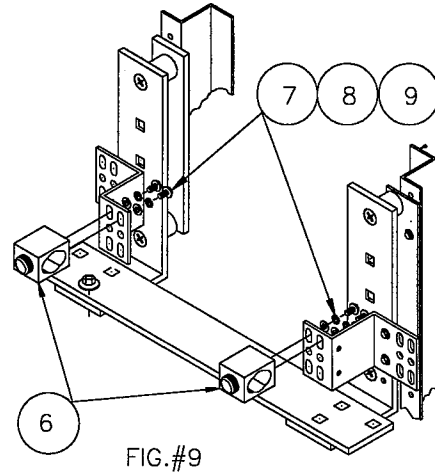

FIG.#9

8. Reference fig. (8) - With both fuse compartment doors open, locate the through hole for the A phase connection on the left side near the top and the C phase connection on the right side near the bottom. Attach with 5/16-18 x 1 1/2" hex washer head screw (item 5) into through holes for the A and C connections. For the B phase connection, remove the cover between the doors. Locate the through hole in the center of the opening. Attach with 5/16-18 x 1 1/2" hex washer head screw (item 5). Torque all connections to the values as specified on the label on the rear side of the dead front cover .

REMOVE COVER BETWEEN DOORS FOR B PHASE CONNECTION

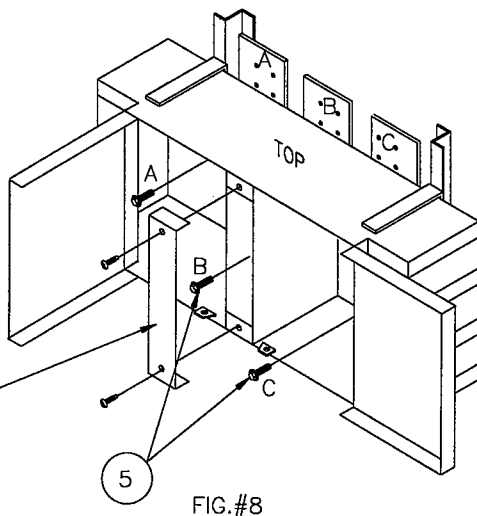

FIG.#8

