

**SIEMENS**



Installation guide

# VersiCharge™ Dual Post and Cable Management System

Electric vehicle charging station

[usa.siemens.com/versicharge](http://usa.siemens.com/versicharge)

## For use with VersiCharge Models:

| VC30GRYU           | VCSG30GRYUW        | VCSG30GCPUW        |
|--------------------|--------------------|--------------------|
| 8EM1312-4AF10-0AA3 | 8EM1312-5AF10-0AA3 | 8EM1312-4CF18-0FA3 |
| 8EM1312-5CF18-0FA3 | 8EM1310-4CF14-0GA0 | 8EM1310-5CF14-0GA0 |
| 8EM1310-4CF14-1GA1 | 8EM1310-5CF14-1GA1 |                    |

Applications include any public or private place where Electric Vehicle (EV) charging is required. These places may include homes, both single and multifamily, places of business, commercial institutions, etc.

NOTE: This instruction outlines the recommended general procedure for installation by a qualified person, as defined by all local electrical codes and/or the NEC®.

PERMITS: Be aware that many areas require special permits and/or utility approvals to install EV charging equipment. Contact your local electrical inspector’s office and your local utility prior to beginning work to understand local requirements.

WARRANTY: See Siemens’ standard terms and conditions below with regards to warranty of purchase.

[usa.siemens.com/versicharge](http://usa.siemens.com/versicharge)

TOUCH UP PAINT: See link below for replacement paint if needed for aesthetic restoration throughout life of post:

<https://www.lvppaints.com/RAL7035-Color-Plate.html>



**DANGER** Hazardous voltage. Will cause death or serious injury. Disconnect before working on this equipment. This indicates a situation where the present voltage could cause injury or death. Extreme caution is required when servicing or installing the equipment referenced.



**DANGER** Explosion hazard. This equipment has arcing or sparking parts that should not be exposed to flammable vapors. Use extreme caution and follow instructions carefully.



**WARNING!** This indicates a situation where failure to follow instructions may be a safety hazard or cause equipment malfunction. Use extreme caution and follow instructions carefully.

These instructions do not purport to cover all details or variations in equipment, or to provide for every possible contingency to be met in connection with installation, operation, or maintenance. Should further information be desired, or should particular problems arise which are not covered sufficiently for the purchaser's purposes, the matter should be referred to the local Siemens sales office or Siemens Customer Service available at 1-800-SIEMENS. The contents of this Instruction Manual shall not become part of or modify any prior or existing agreement, commitment, or relationship. The sales contract contains the entire obligation of Siemens. The warranty contained in the contract between the parties is the sole warranty of Siemens. Any statements contained herein do not create new warranties or modify the existing warranty.

## Dual Post and Cable Management System for Siemens VersiCharge™

VersiCharge units sold separately

### Features:

- Single or dual mount pedestal
- Siemens VersiCharge standard bolt pattern
- 4" Aluminum pedestal post - .120" thick
- Aluminum pedestal base - 3/4" thick
- Powder coated with primer undercoat for environmental durability
- Pedestal doubles as an electrical raceway

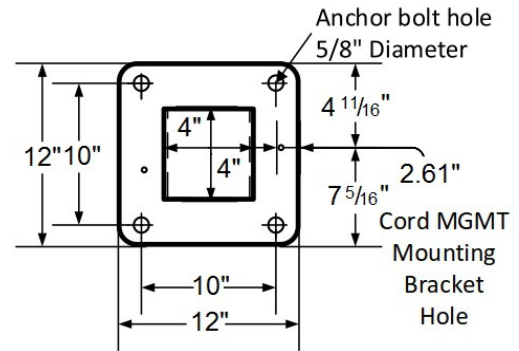

Viewed from Underneath Pedestal Base

### Supplied Parts:

#### Pedestal

- One 4" x 4" x 48" Square Pedestal
- One 4" x 4" Plastic End Cap Plug
- Two 1/4"-20 x 1/2" Machine Button Head Philips Screws
- Two 10-32 x 1" Machine Button Head Tamper Resistant Screws
- One 3/4" NM Flex Right-Angle Connector
- One 3/4" NM Flex Straight Thru Connector
- One 1" to 3/4" Reducer Washer
- One 3/4" x 16" NM Liquid-Tight Flexible Conduit

#### Cord Retractor (Optional)

- One 2" x 2" x 78-3/4" Aluminum Post (1-for single unit or 2-for dual)
- One White Polyester Cable
- One 5/16" x 3/4" Bolt with Washer
- One 3/8" x 1 1/4" Bolt with Washer
- One Cord Clamp for Cord Retractor
- One Cast Iron Counterweight (11 lbs.)

#### Miscellaneous

- Four Drop-In Anchors
- Four Stainless Anchor Bolts with Washers
- One Tube of Silicone Sealer
- Two 0.312" Locking Hole Plugs
- One 1" Locking Hole Plug
- Two 0.375" Locking Hole Plugs

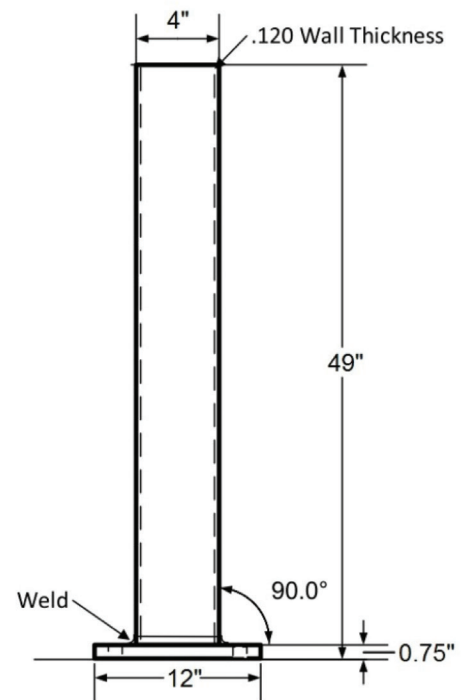



**DANGER** Hazardous voltage. Will cause death or serious injury. Please consider all safety warnings in the VersiCharge Installation and Operation manual (document # 813776) prior to wiring. To reduce the risk of fire, connect only to a circuit provided with 40 amperes maximum branch circuit overcurrent protection in accordance with the ANSI/NFPA 70 NEC. VersiCharge EV charging stations can draw up to -48A at 240 VAC, 50/60 Hz (11.5kW of power). Refer to the VersiCharge Installation and Operations Manual for instruction on removing the cord-and-plug assembly and steps for hardwired installation. Use 6-8 AWG, 75°C copper wire to connect to supply circuit. Ensure breaker is off during all electrical work.

All pedestals shall be factory pre-drilled for installing two (2) Siemens VersiCharge EVSE units. The post product is compatible with the following VersiCharge models:

| VC30GRYU           | VCSG30GRYUW        | VCSG30GCPUW        |
|--------------------|--------------------|--------------------|
| 8EM1312-4AF10-0AA3 | 8EM1312-5AF10-0AA3 | 8EM1312-4CF18-0FA3 |
| 8EM1312-5CF18-0FA3 | 8EM1310-4CF14-0GA0 | 8EM1310-5CF14-0GA0 |
| 8EM1310-4CF14-1GA1 | 8EM1310-5CF14-1GA1 |                    |

Installation height is regulated by NEC; however, this can vary based on local jurisdiction. NEC® 2011 specifies: Outdoor (NEC® Article 625.30B) = installation 24-48 inches above ground level. Use appropriate tools and hardware to fasten equipment, see details.

### Concrete Pad, Power Feed and Anchor Requirements

Provide an approved concrete or composite base with the top flush at ground level, with 12" conduit stub-up centered. The conduit shall be sized to provide 3 wires (L1, L2, GND) for each charger being mounted. The base size should be a minimum of 18" x 18" x 18" and can be poured or pre-cast / pre-made. Installation of protective concrete-filled steel bollard posts and/or curb stops to protect the charger from an automobile strike is recommended. Feed-wire size shall be determined by a qualified electrician using industry standard calculations. Using the provided drop-in anchors with a concrete base, secure the pedestal to the base. If using a composite base, secure per manufacturer's instructions. Remove the pedestal access plate and place to the side. There is an option to run the power supply underground bringing it in through the bottom of the pedestal or, if the conduit is run above ground, the wires may be brought in through the side of the post by drilling a hole for the conduit penetration through the pedestal.

**VersiCharge Models:**

|                    |                    |                    |
|--------------------|--------------------|--------------------|
| 8EM1312-4AF10-0AA3 | 8EM1312-5AF10-0AA3 | 8EM1312-4CF18-0FA3 |
| 8EM1312-5CF18-0FA3 | 8EM1310-4CF14-0GA0 | 8EM1310-5CF14-0GA0 |
| 8EM1310-4CF14-1GA1 | 8EM1310-5CF14-1GA1 |                    |

## Single VersiCharge Mounting

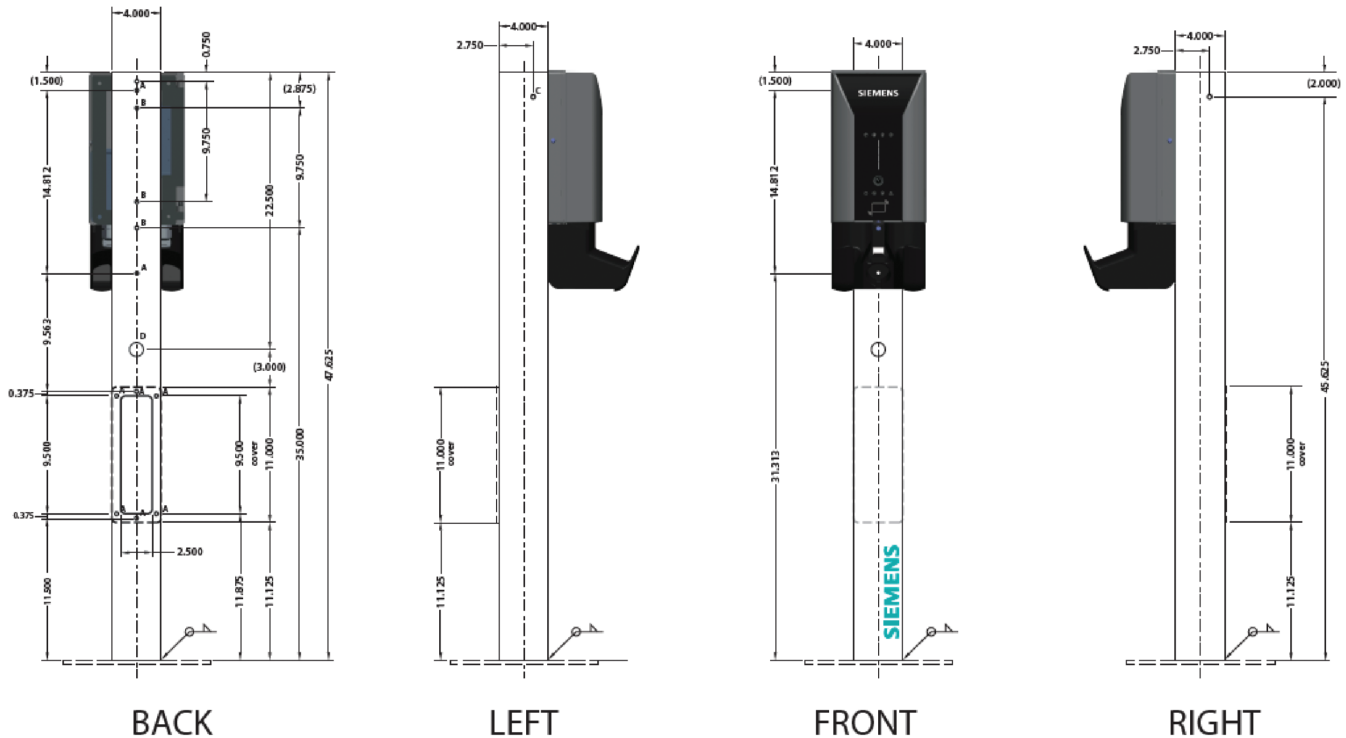

1. Locate center of pedestal to attach the VersiCharge mounting bracket.
2. Locate 2 mounting bracket holes as mentioned above (items A and B 9.75 inches apart and 0.75 inches from the top)
3. Attach the Mounting Bracket to the pedestal using two ¼-20 Philips screws (D), torque to 14.5 lb.-in, placing silicone sealer at each hole to provide a liquid-tight securement.
 

**NOTE:** For installation, the mounting-bracket hinges will be pointing to the ceiling, and the flat side of the bracket will be against the pedestal
4. Charger Mounting:
  - a. Slide the VersiCharge on to the hinges.
  - b. Rotate to the right until the unit clicks and is closed.
  - c. Secure Charger to Mounting Bracket: Using the kit-supplied tamper-resistant screw— secure the charger cover with one screw on the side. Use the second screw (underneath the charger) to secure Front Cover to the Charger.
  - d. Install Holster to Charger: Align Holster with guides in charger. Using the kit-supplied tamper-resistant screw, use the third screw to secure the holster to the charger (hole at the top of the holster).

3. Standard installation – using the kit-supplied lag screw, screw into the pedestal.

Silicone sealer can be placed at each hole to provide a liquid-tight securement
5. Install NM flex conduit to the bottom opening of the VersiCharge unit and terminate using provided ¾" NM straight connector and reducer washers.
6. Attach the NM flex conduit to the center hole (underneath the charger) of the pedestal using the provided ¾" NM right-angle connector.
7. Pull/feed the power wires through the conduit and trim to the proper length to reach the charger connection points. Leave enough slack (15" to 20") in the wires inside the post to allow unrestricted access. Using a fold in the wires and a zip-tie(s), secure the wire bundle so wires are not touching the inside of the pedestal post.
8. Continue with manufacturers' instructions for 'Wiring Steps for Hard-Wired Installation' in the VersiCharge Quick Start Guide .

## Dual VersiCharge Mounting

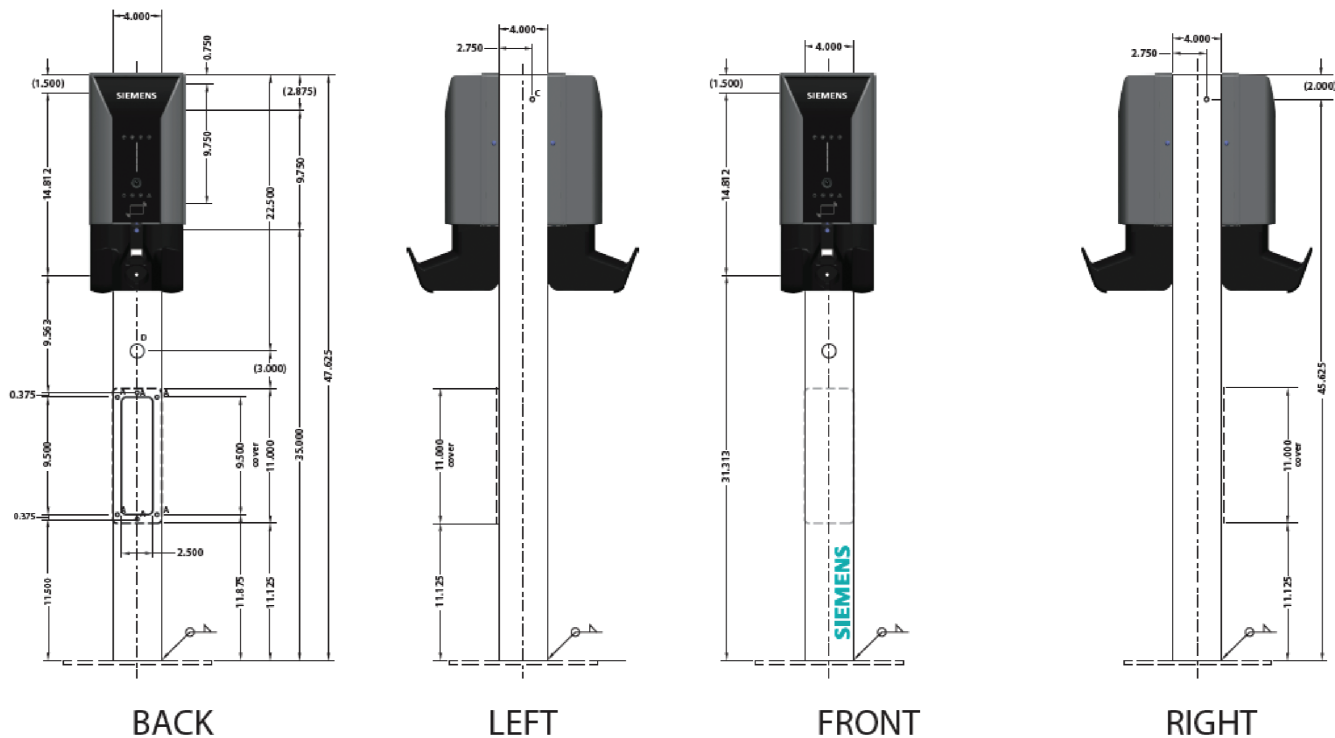

1. All steps for single unit mounting shall be repeated on two (2) sides of the pedestal.

## Single Cord Retractor Mounting

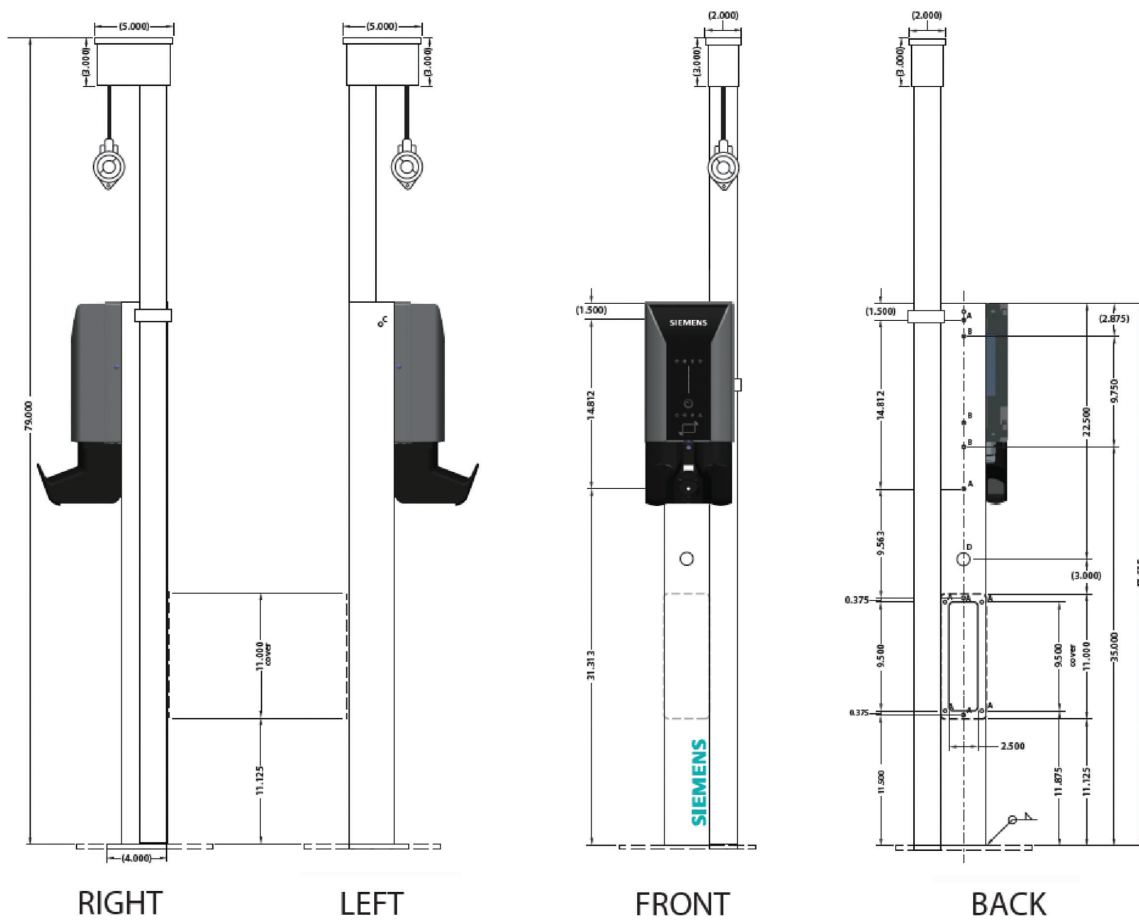

1. Align the square Cord Retractor body along the right side of the charging station.
2. The upper retractor bracket is threaded and slides the length of the retractor post. Locate the  $\frac{5}{8}$ " hole located at the top of the pedestal on right side, align unit with mounting bracket in place. Place the washers on the  $\frac{5}{16}$ " x  $\frac{3}{4}$ " bolt before inserting to space the bracket bolt so it is fully threaded into the upper bracket but DOES NOT penetrate the retractor post. Insert bolt with washer from the inside of the post and tighten, torque to 14.5 lb.-in. Use silicone sealer between the pedestal post and retractor post to make it liquid-tight.
3. Make sure unit is plumb with hole at the baseplate, and anchor to baseplate with  $\frac{3}{8}$ " anchor bolt.
4. Tighten all bolts. Seal pedestal bolt hole with an outdoor rated silicone to ensure it is watertight.
5. Install cord clamp in a location on the cord which keeps it off the ground when the connector is in the 'parked' or 'holstered' position. Use black electrical tape to take up any gap between the cord and the inside of the clamp. Tighten the clamp enough to not allow the cord to slide.



## Dual Cord Retractor Mounting

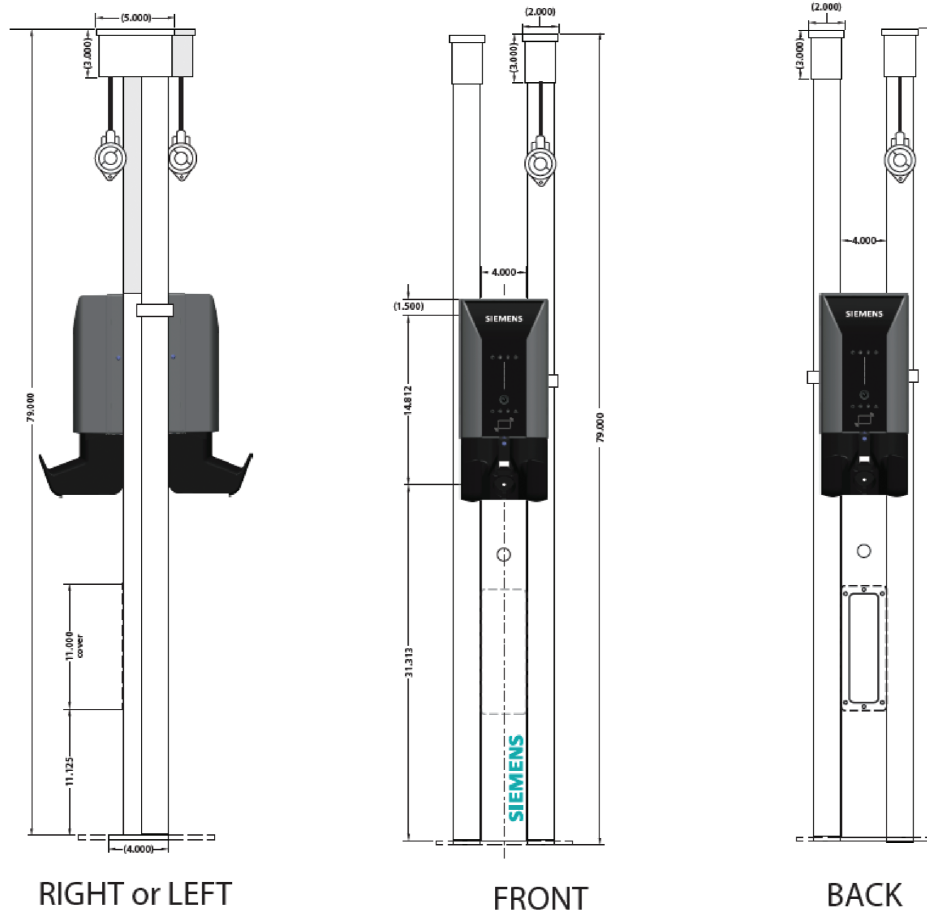

RIGHT or LEFT

FRONT

BACK

### Top View

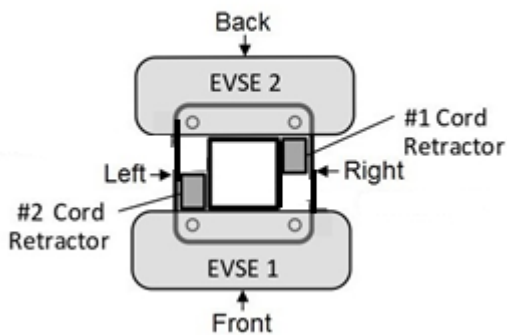

1. All steps for single cord retractor shall be repeated on two (2) sides of the pedestal.

## Installing the Access Cover and Top Cap

Once all the above steps are complete and all screws, bolts, fittings, etc. are tight, place a thin bead of silicone sealer around the perimeter of the access plate and screw the plate onto the post using the provided stainless torx head screws. Wipe off any excess sealer. Place a generous bead of silicone sealer around the perimeter of the top cap and insert the cap into the pedestal post. A rubber mallet is recommended to properly seat the top cap. Wipe off any excess sealer.

## Power the Station(s)

1. Turn on the power feed to the station(s) and test as per the VersiCharge installation manual.

### Pedestal dimensions

|   | QUANTITY   | SIZE        | DEPTH |
|---|------------|-------------|-------|
| A | 8 (PLACES) | 10-32 THD   | THRU  |
| B | 4 (PLACES) | 1/4"-20 THD | THRU  |
| C | 0 (PLACES) | φ 0.312     | —     |
| D | 1 (PLACES) | φ 1.095     | THRU  |

|   | QUANTITY   | SIZE        | DEPTH |
|---|------------|-------------|-------|
| A | 8 (PLACES) | 10-32 THD   | —     |
| B | 4 (PLACES) | 1/4"-20 THD | —     |
| C | 0 (PLACES) | φ 0.312     | THRU  |
| D | 1 (PLACES) | φ 1.095     | —     |

|   | QUANTITY   | SIZE        | DEPTH |
|---|------------|-------------|-------|
| A | 8 (PLACES) | 10-32 THD   | THRU  |
| B | 4 (PLACES) | 1/4"-20 THD | THRU  |
| C | 0 (PLACES) | φ 0.312     | —     |
| D | 1 (PLACES) | φ 1.095     | THRU  |

|   | QUANTITY   | SIZE        | DEPTH |
|---|------------|-------------|-------|
| A | 8 (PLACES) | 10-32 THD   | —     |
| B | 4 (PLACES) | 1/4"-20 THD | —     |
| C | 0 (PLACES) | φ 0.312     | THRU  |
| D | 1 (PLACES) | φ 1.095     | —     |

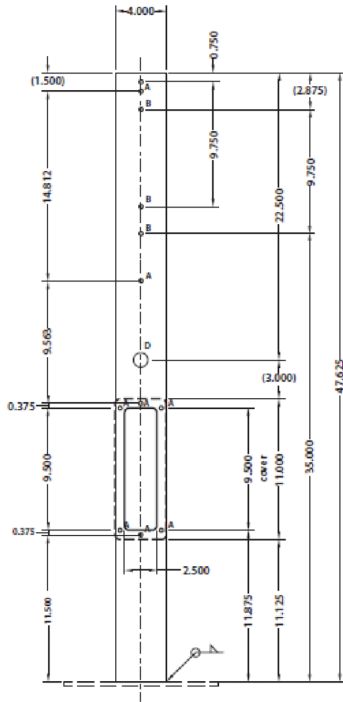

BACK

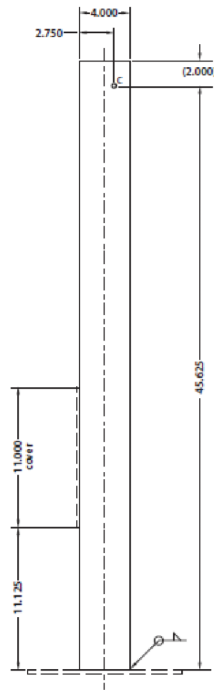

LEFT

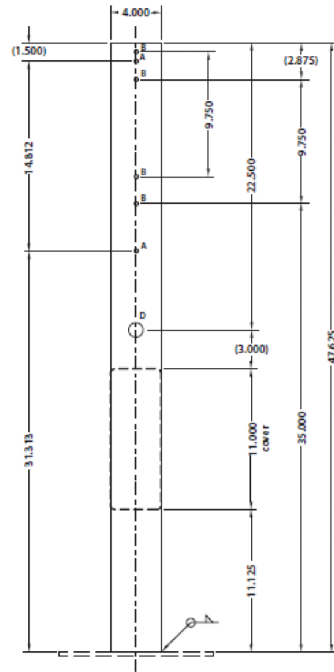

FRONT

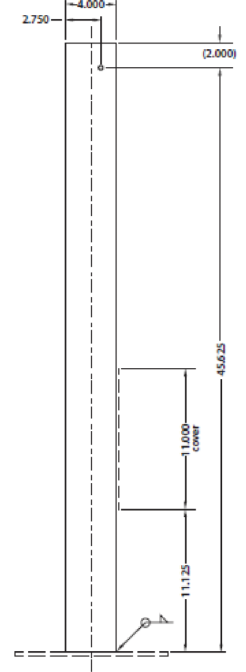

RIGHT



**Published by Siemens Industry, Inc. 2021**

Siemens Industry, Inc.  
3617 Parkway Ln.  
Peachtree Corners, GA 30092

Phone: +1 (800) 333-7421  
helpline.sii@siemens.com  
usa.siemens.com/versicharge  
Engineering doc no: R814225 Rev 3  
Article No. SIDS-T40099-00-4AUS  
Printed in USA  
All Rights Reserved  
© 2021, Siemens Industry, Inc.

The technical data presented in this document is based on an actual case or on as-designed parameters and, therefore, should not be relied upon for any specific application and does not constitute a performance guarantee for any projects. Actual results are dependent on variable conditions. Accordingly, Siemens does not make representations, warranties, or assurances as to the accuracy, currency or completeness of the content contained herein. If requested, we will provide specific technical data or specifications with respect to any customer's particular applications. Our company is constantly involved in engineering and development. For that reason, we reserve the right to modify, at any time, the technology and product specifications contained herein.