

SIEMENS DIGITAL TWIN

# Forces and movement

## What are forces and where do they come from?

In physics, forces are pushes or pulls that can affect an object's speed, direction or shape. Important forces you might have heard of include gravity, friction and electromagnetism.

Some forces exist naturally and are non-contact, meaning they can affect objects without touching them. Some examples are gravity, which is the force that pulls you back to the ground when you jump, or a magnet which can lift metal objects, like a paper clip, when in close proximity.

Other forces, like friction, do require contact and are created when two objects move against each other. Frictional force makes it harder for one object to move past another, and can actually be useful in some situations.

One example is car tyres, which create friction between a moving car and the road to prevent it from skidding. Our shoes also act in the same way, to stop us slipping on any surfaces we walk on.



### Did you know?

**All forces come in pairs and no force can exist by itself. Every action has an equal and opposite reaction.**

Forces and their effects can also change with speed, depending on how fast an object is moving. Air resistance is an example of a frictional force that can be unhelpful for moving objects, like bicycles or cars. The faster a vehicle moves, the bigger the air resistance becomes.

The top speed (the fastest possible speed) of a vehicle, like a bicycle or car, is reached when the cyclist or engine eventually generates enough force to balance the air resistance. Engineers can adapt the design of vehicles to reduce air resistance and help them achieve their top speed faster.

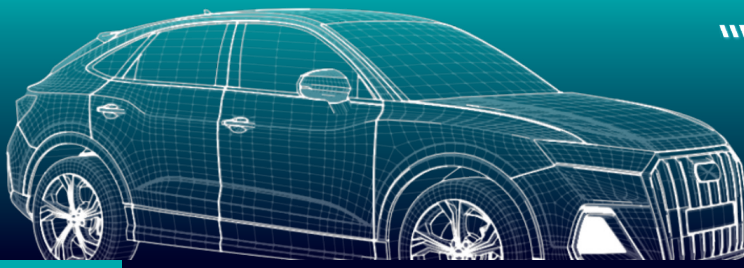

### Did you know?

Friction causes heat due to the amount of energy that is created when two objects move against each other repeatedly. Rub your hands together quickly and try it for yourself!



### Design a parachute activity

In some situations, like parachuting for example, air resistance can be a helpful thing as it can be used to counteract gravity and ensure a safe descent to the ground.

Think about a parachute in motion - which of the two forces would be the pull and which would be the push? Are there aspects of the parachute design that would increase the air resistance and reduce the effects of gravity?

With this in mind, your challenge is to **design the most effective parachute possible** to ensure your parachute user reaches the ground safely.

#### **You will need the following:**

- small figure, soft toy or weight
- plastic bag
- string
- paper
- masking tape
- scissors

Either working by yourself or with a partner, design your parachute using just the above materials. Once you're happy with your design, it's time to attach your figure or weight and test it out.

Agree a fair test environment with the rest of the class and test all of the parachutes at the same time. Take notes on your parachute's performance and compare with your classmates. **Whose parachute performed the best and why do you think that was?**

SIEMENS DIGITAL TWIN

# Aerodynamics and design

## What is aerodynamics?

Aerodynamics is a special branch of physics that refers specifically to the way air moves around things, or objects. Anything that moves through the air creates friction with the particles within it. The faster an object moves through air, the more it reacts to this friction and this is what we call air resistance.

When thinking about objects that move through the air, we might immediately think of flying things like birds and aircrafts, like planes and helicopters - even space rockets! However aerodynamics also applies to non-flying objects like cars and bicycles, as they still move through the air at speed.



## Did you know?

Someone who specialises in aerodynamics is called an aerodynamicist. These specialised professionals might go to work for organisations like the UK Space Agency, who look after our country's efforts to explore and benefit from space.

## Aerodynamics in design

The study of aerodynamics can be very useful in certain industries, like car and aircraft manufacturing. When aerodynamics are applied to the design of a vehicle, it can be adapted to reduce the effects of air resistance, therefore increasing speed and ease of movement. We call this streamlining and this ultimately allows a vehicle to move at more efficient and faster speeds, which is especially useful for the likes of racing cars or planes.

KS3

### Four Forces of Flight

At the core of aerodynamics are the four forces of flight - lift, weight, thrust and drag. These are the four forces that allow an object to move up, down, faster and slower through the air.

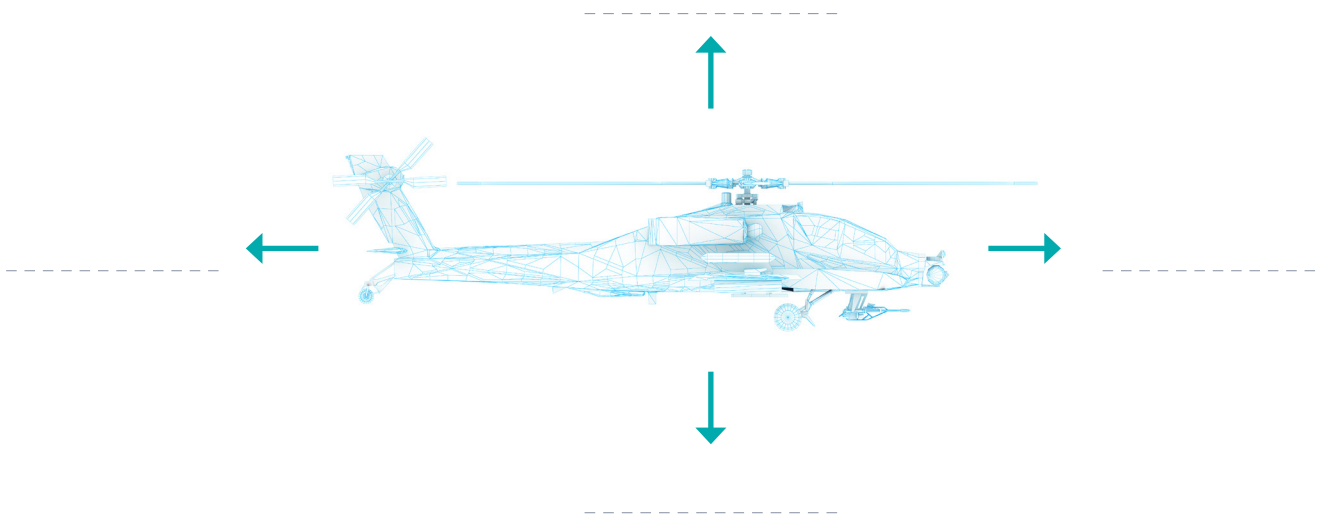

### Four Forces of Flight Activity

Can you match the following description to the correct force of flight and label it in the correct position on the diagram above?

Thrust	This is a force that works to slow something down, which makes it harder for an object to move through the air. The shape of an object also changes the amount of this force, and most round or narrow surfaces usually have less of it than wider surfaces.
Drag	This force is specific to gravity, the natural pull that affects all objects. To fly, an object needs to counteract gravity and therefore requires something to push it in the opposite direction. The mass of an object dictates how strong the push needs to be. For example, a bird needs a lot less upward push than a plane does.
Lift	This force is the opposite of drag, as it's the push that moves something forward. For example, an aircraft must have more of this force than drag to keep moving forward. A jumbo jet might get this push from its engines.
Weight	This is the force that is the opposite of weight, the push that allows something to fly. Everything that flies must have more of this than weight. A hot air balloon has a lot of this force because the hot air inside is lighter than the air around it. Hot air rises and carries the balloon with it.

SIEMENS DIGITAL TWIN

# Digital Twins

## What are digital twins?

Digital twins are virtual copies or doubles of real-world things - such as a product, machine or process. You might have heard of simulations before, which are very similar. Digital twins are incredibly useful as they can show us a virtual model of something that we can then test and measure, ahead of creating the real thing!



## Did you know?

**Simulate means to imitate something, like a situation or a process.**

Digital twins allow engineers and manufacturers to experiment with things like design, performance and safety to allow them to find the best possible solutions. These digital replicas can be used by engineers to understand how machines perform and how they can be improved and maintained. An engineer can build a digital prototype - a first version of a product - and test it under lots of different conditions, to make sure it's the best it can possibly be.

The virtual twin of a product can also accompany it like a digital shadow through all the stages of its lifetime – from initial design through to real-life use and even recycling, when it can no longer be used anymore.

## Digital twins and the future

As our world becomes more and more virtual, software like digital twins are becoming even more commonplace. It's not unusual for these types of software to be used in industries and businesses to help them run more successfully, and make smarter decisions with the help of modern technology.



KS3

SIEMENS



### Design your own digital twin activity

How could you improve your own school for the future by introducing a new technology, machine or process? Maybe it's a new school robot to help clean up after lunch hour or perhaps your school would benefit from a new lunch pass technology.

Think about your own idea and how you would design and explore it in a digital twin environment first.

Write a pitch for your idea and outline the benefits it would bring to your school, how a digital twin would help you with the design and exploration phases, the conditions you would test it under and how you plan to make it safe for a real-life rollout in the near future.

You could even draw out the phases of your project on a poster or make a digital presentation on a computer or tablet to present back to your class.